



Electronic Service Manuals

This electronic document is provided as a service to our customers. We do not create the contents of the information contained in this document. Should you have detailed questions pertaining to the information contained in this document, you may contact Michco, or the manufacturer which provided the original information in this electronic deliverable. Michco's only part in this electronic deliverable was the electronic assembly process. By providing this manual on line we are not guaranteeing parts availability.

You may contact Michco through the following methods:

Phone (517) 484-9312 or (800) 331-3339

2011 N. High St. -- Lansing, Michigan -- 48906

Fax: (517) 484-9836

Email: CustServe@Michco.com

Web site: www.Michco.Com

Parts Web site: www.FloorMachineParts.Com

Order Parts on Line at:

www.FloorMachineParts.Com

Directly to Parts & Service:

By Email: **Shop@Michco.com**

By Fax: (517) 702-2041

By Voice: Use numbers above.

Serving the Cleaning Industry Since 1922

Notice: All copyrighted material remains property of original owners, all trademarks are property of respective owners. Manuals are subject to Manufacturer's reproduction limitations. Originals or reproductions were provided by manufacturers through a request. We make no warranty as to the correctness of information provided in this document and you assume all risk. By placing these manuals on line we are not declaring our corporation to be an manufacturer authorized dealer or provider, please check our web site for authorized manufacturers we represent.

Spare Parts List

**(1.009-057.0, 1.009-016.0, 1.009-018.0,
1.009-017.0, 1.009-036.0)**

Floor Burnisher

From Serial Number (Ref No1*)

*See Serial Number Page
or call manufacturer

How to Use this Spare Parts List

The PARTS LIST section contains assembled parts illustrations and corresponding parts list. The parts lists include a number of columns of information:

- REF - column refers to the reference number on the parts illustration.
- PART NO. - column lists the part number for the part.
- QTY - column lists the quantity of the part used in that area of the machine.
- DESCRIPTION - column is a brief description of the part.
- SERIAL NO. FROM - If this column has an (*) and a Reference number, see the SERIAL NUMBERS page in the back of your manual. If column has two asterisk (**), call manufacturer for serial number. The serial number indicates the first machine the part number is applicable to. The main illustration shows the most current design of the machine. When a boxed illustration is shown, it displays the older design.
- NOTES - column for information not noted by the other columns.

NOTE: *If a service or option kit is installed on your machine, be sure to keep the KIT INSTRUCTIONS which came with the kit. It contains replacement parts numbers needed for ordering future parts.*

How to Use this Spare Parts List 2
Table of Contents 3
Deck 4
Drive/Pad Lock 6
Electrical 8
Handle 10
Motor 12
Wiring - 120V 14
Wiring - 230V 15
Serial Number 16

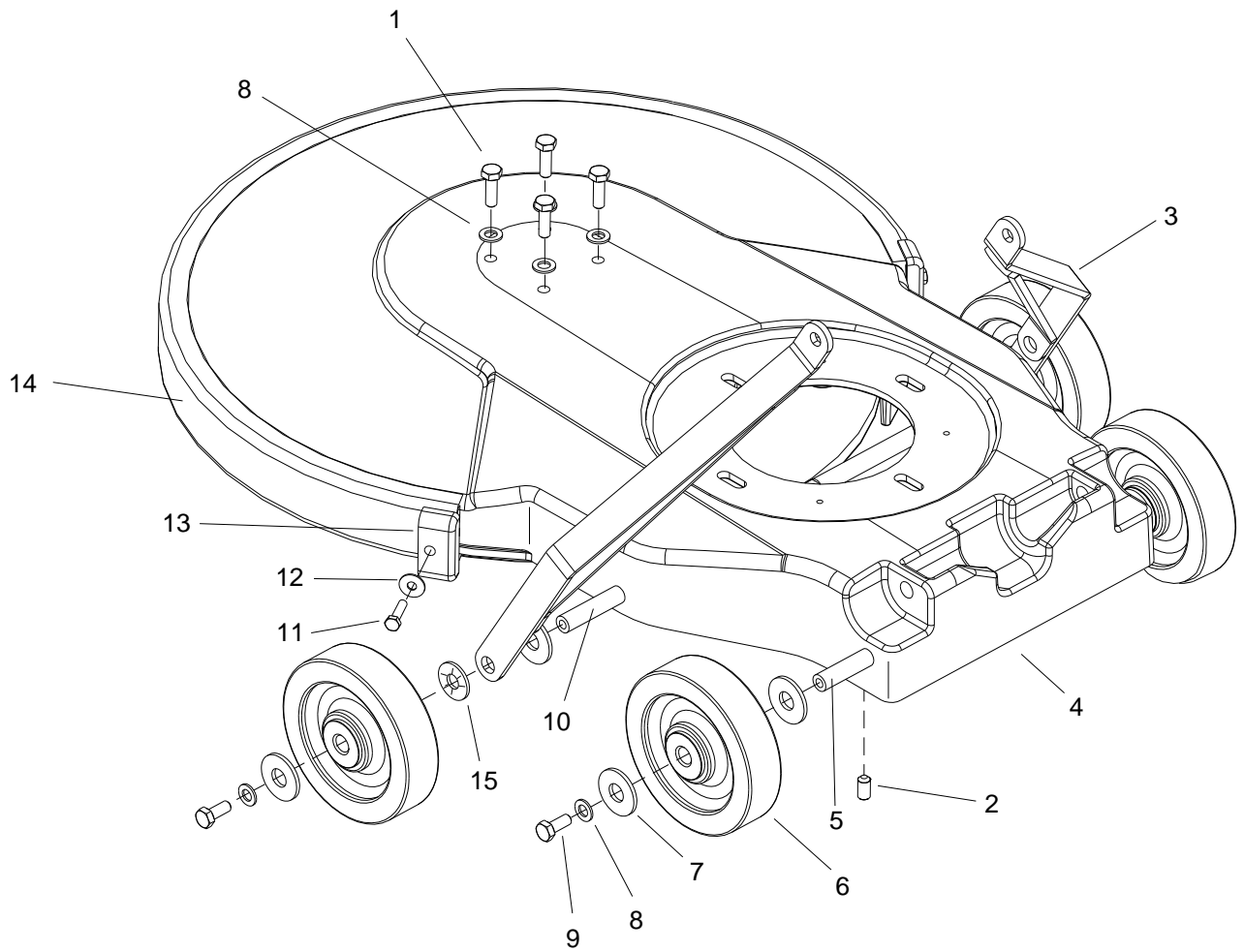

REF	PART NO.	QTY	DESCRIPTION	SERIAL NO. FROM	NOTES
1	86288730	4	SCR, M8 X 25HHCS		
2	86288740	2	SET SCR, 8MMX1.25X8MM CUP PT		
3	86215460	2	BRACKET, HANDLE LINK		
4	86288990	1	DECK, 20 IN BURNISHER, GRAY		
5	86214930	1	AXLE, MAIN POLISHER		
6	86226020	4	WHEEL, 5D X 1.25 X 13MM ID GRY		
7	86225720	8	WASHER, 14MM ID X 36MM OD		
8	86137280	8	WASHER, M8 FLAT DIN125A PLT		
9	86136640	4	SCR, M8-1.25 X 20 HHMS PLTD		
10	86214950	1	AXLE, MAIN BURNISHER		
11	86372780	2	SCREW, M6-1 X 22, HHCS, BLK		
12	86137340	2	WASHER, M6 FLAT		
13	86216600	2	CAP, EXTRUSION		
14	86216360	1	BUMPER, EXTRUSION 42.6 IN		
15	86222270	2	NUT, PUSH FLAT RD .51 ID		

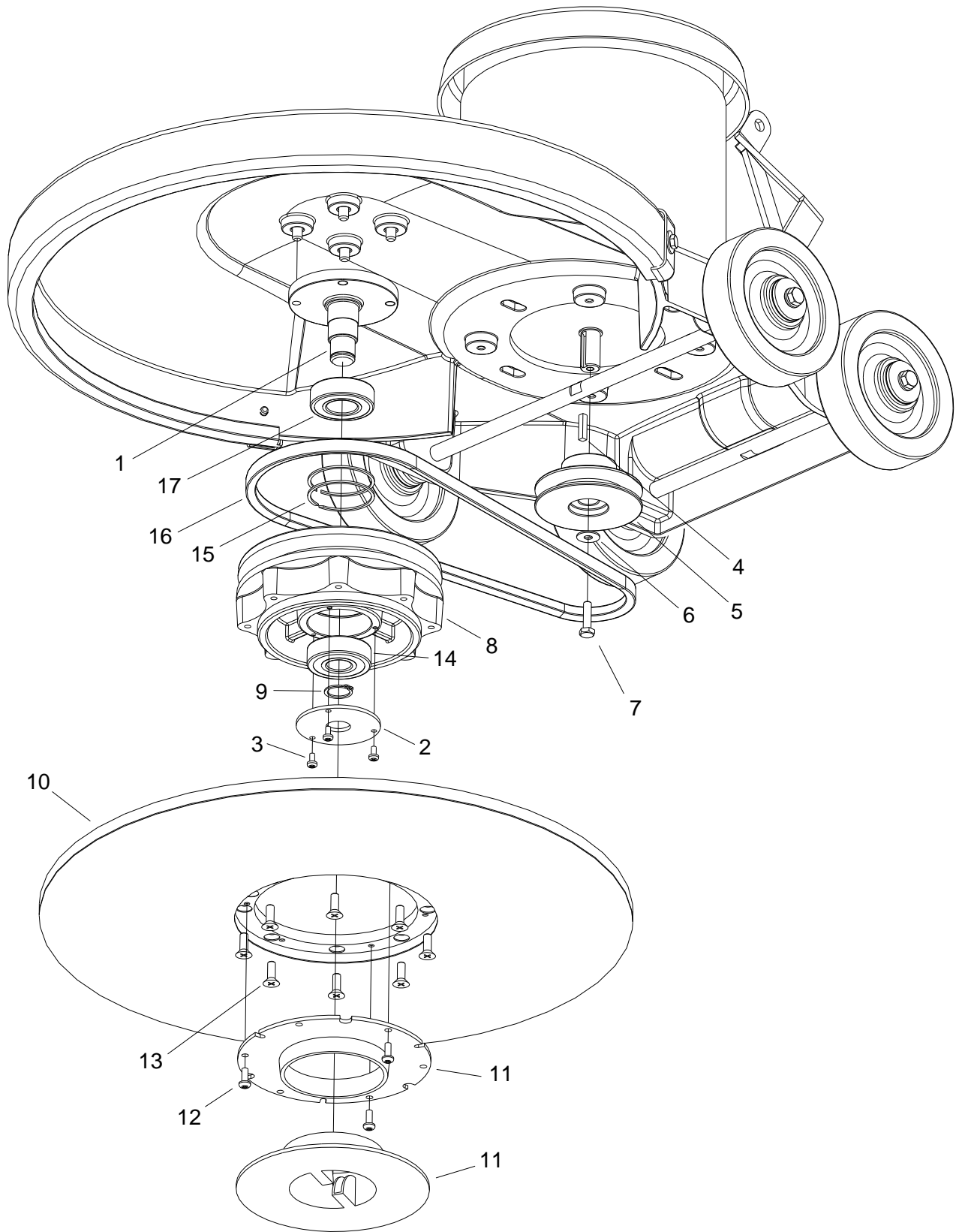

REF	PART NO.	QTY	DESCRIPTION	SERIAL NO. FROM	NOTES:
1	86214940	1	AXLE, PAD DRIVER		
2	86217510	1	COVER, BEARING		
3	86276730	3	SCR, M4 X 8MM PPHMS		
4	86004820	1	KEY, 3/16 SQ X 7/8 CRS		
5	86223280	1	PULLEY, .625 X 3.45		
6	86225730	1	WASHER, M6 (20.5OD X 1.67) PLT		
7	86275570	1	SCR, 1/4-20 X 1.00 HHCS GR5		
8	86223290	1	PULLEY, BURNISHER		
9	86223470	1	RING, 20M EXTERNAL SNAP		
10	86222480	1	PAD DRIVER, 20 IN BURNISHER FLEX		
11	86246740	1	LOCK, PAD DRIVER BLUE		
12	86276740	3	SCR, #10 X 3/8 PPHST TYPE B		
13	86006670	8	SCR, 1/4-20 X 3/4 FHCS		
14	86223970	1	BEARING, 20MM X 52MM		
15	86223480	2	RING, 52MM INTERNAL SNAP		
16	86215330	1	BELT, DRIVE 38 IN		
17	86223980	1	SEALED BALL BEARING, 25MM X 52MM		

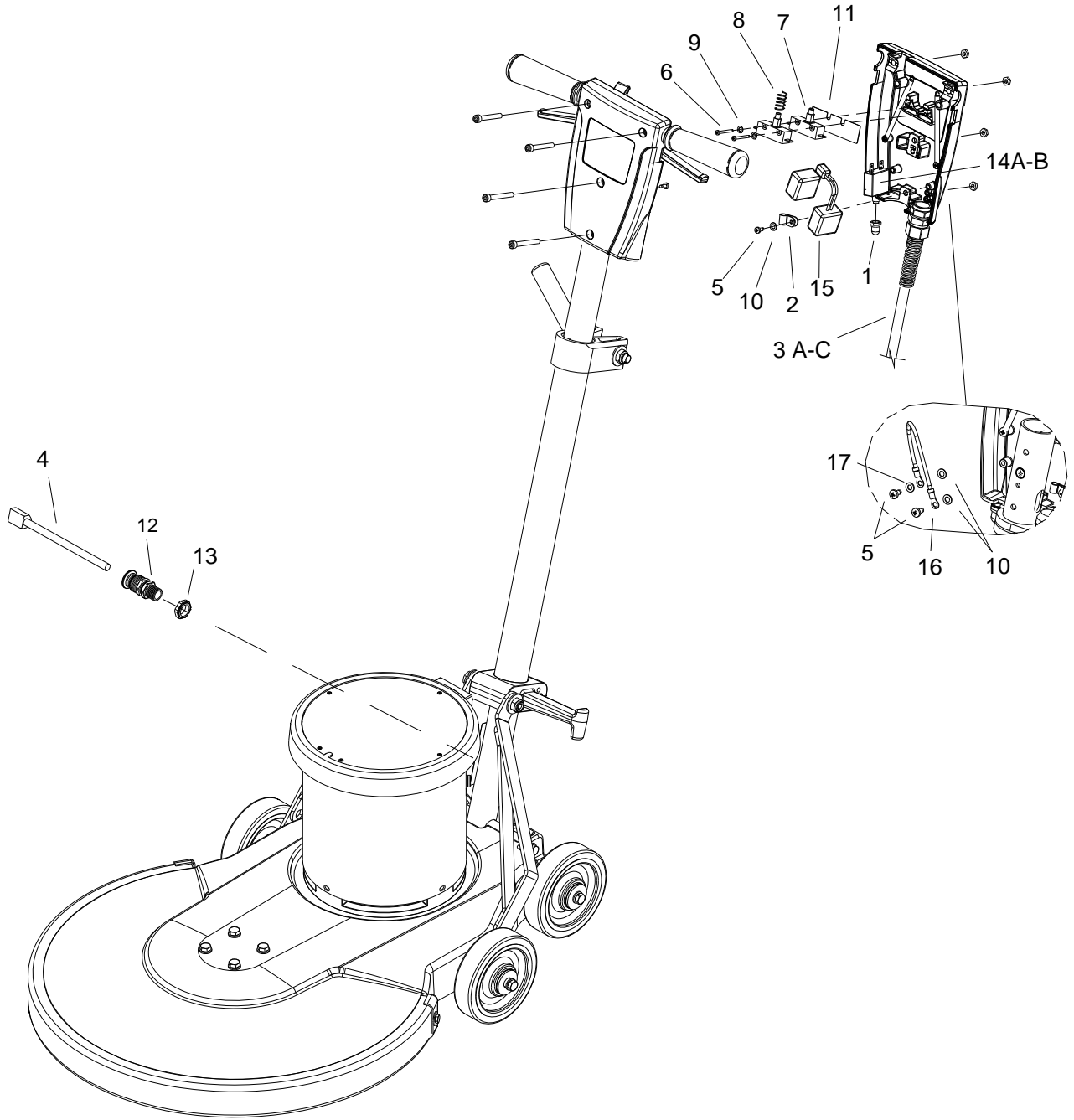

REF	PART NO.	QTY	DESCRIPTION	SERIAL NO. FROM	NOTES
1	86002010	1	BOOT, 3/8 CIRCUIT BREAKER		
2	86198450	1	CLAMP, 5/16 NYLON		
3A	86369110	1	CORD SET, EURO,75', BLK		LB1500IE
3B	86369120	1	CORD SET, AS/NZ, 75', BLK		LB1500IA
3C	86369100	1	CORD SET, ST, 14/75', YLW		LB1500, U1500,SPT1500
4	86216920	1	CORDSET, 14/3 X 52 IN, SJT, BLK		
5	86288450	3	SCR, M4.8 X 10 HHTF TYPE B		
6	86136780	2	SCR, M3.5 X 40 PHTF		
7	86007110	2	SWITCH, 25A SPST 125-250V SNAP		
8	86224750	1	SPRING, COMP, .48OD X .91		
9	86137290	2	WASHER, M4 LOCK		
10	86137330	3	WASHER, M5 LOCK		
11	86215140	1	BARRIER SHEET		
12	86224930	1	STRAIN RELIEF, 14/3 STRAIGHT		
13	86224300	1	SPACER, POLISHER HANDLE		
14A	86312460	1	BREAKER, 14A VDE CIRCUIT		120V
14B	86291460	1	BREAKER, 11A VDE CIRCUIT		230V
15	86217770	1	EMC FILTER ASSY, MB2000I		230V
16	86352480	1	WIRE, 14AWG, #10R X #10R, YLW W/GRN		
17	86173350	1	WASHER, M5, FLAT, ISO7089, SS		

REF	PART NO.	QTY	DESCRIPTION	SERIAL NO. FROM	NOTES
1	86215130	1	BAR, HANDLE ADJUST		
2	86366010	1	BUMPER, FLOOR MACHINE		
3	86004070	2	GRIP, POLISHER HANDLE		
4	86311800	1	TUBE ASSY, HANDLE ADJ.		
5	86005150	1	LOCK, SAFETY HANDLE		
6	86005160	2	LEVER, SWITCH		
7	86136350	4	NUT, M6 HEX FINISH		
8	86136360	2	NUT, M10 X 1.5 HEX NYLOK PLTD		
9	86222560	1	PIN, PIVOT, HANDLE ADJUST		
10	86223550	1	ROD, HANDLE ADJUST		
11	86274230	2	SCR, M8 X 30 HHMS		
12	86136670	3	SCR, M6 X 45 SHCS, BLK		
13	86136680	2	SCR, M6 X 50 SHCS, BLK		
14	86288450	5	SCR, M4.8 X 10 HHTF TYPE B		
15	86136720	1	SCR, M10 X 1.50 X 90 HHCS PLTD		
16	86224740	2	SPRING, EXT, .50D X 3.5L		
17	86225370	1	TUBE, GRIP HANDLE		
18	86137280	2	WASHER, M8 FLAT DIN15A PLT		
19	86279080	3	WASHER, M4 FLAT DIN125A PLT		
20	86010720	3	WASHER, M10 X 30 PLTD		
21	86225710	1	WASHER, BEARING (HANDLE ADJ)		
22	86137330	2	WASHER, M5 LOCK SHAKEPROOF PLTD		
23	86224290	2	SPACER, .317ID X .50D X .44LG		
24	86310950	1	CLAMP, HANDLE		
25	86218500	1	HANDLE, BRNSHR EXTND		
26	86365950	1	HOUSING, FM HANDLE, REAR		
27	86365960	1	HOUSING, FM HANDLE, FRONT		
28	86368870	1	BRKT, STRAIN RELIEF MT		
29A	86365780	1	STRAIN RELIEF, METAL, LARGE		LB1500, U1500, SPT1500
29B	86365760	1	STRAIN RELIEF, METAL, SMALL		LB1500IE, LB1500IA

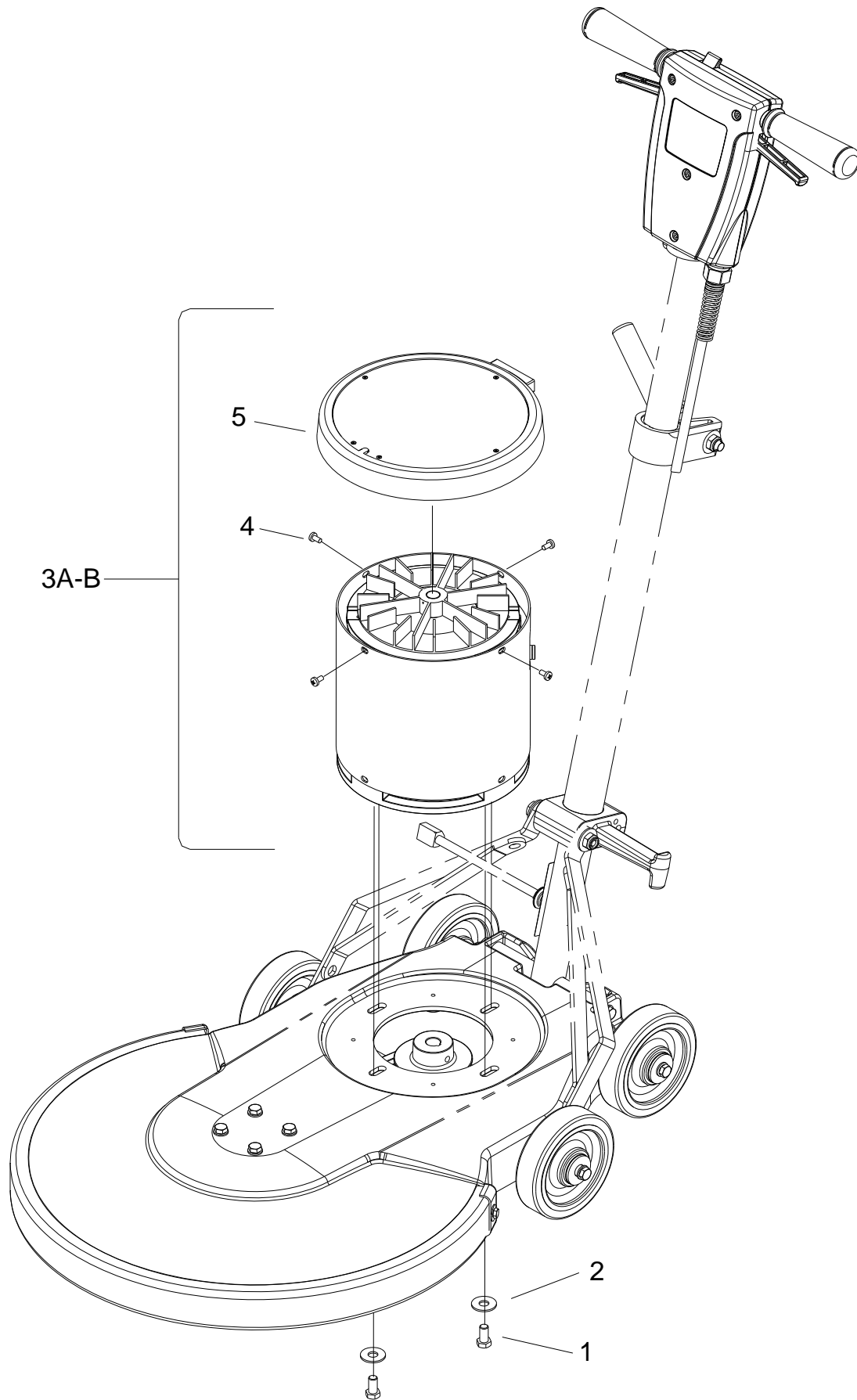

REF	PART NO.	QTY	DESCRIPTION	SERIAL NO. FROM	NOTES
1	86006920	4	SCR, 3/8-16 X 3/4 HHCS GR5 PLT		
2	86010720	4	WASHER, M10 X 3 PLTD		
3A	86312240	1	MOTOR, 115V 1.5HP 3000RPM		
3B	86312230	-	MOTOR, 230V 1.5HP 3000RPM		
4	86223680	8	SCR, M5 X .8 X 10MM PHMS BLK		
5	86217500	1	COVER ASM, MOTOR 1.75HP		

Wiring - 120V

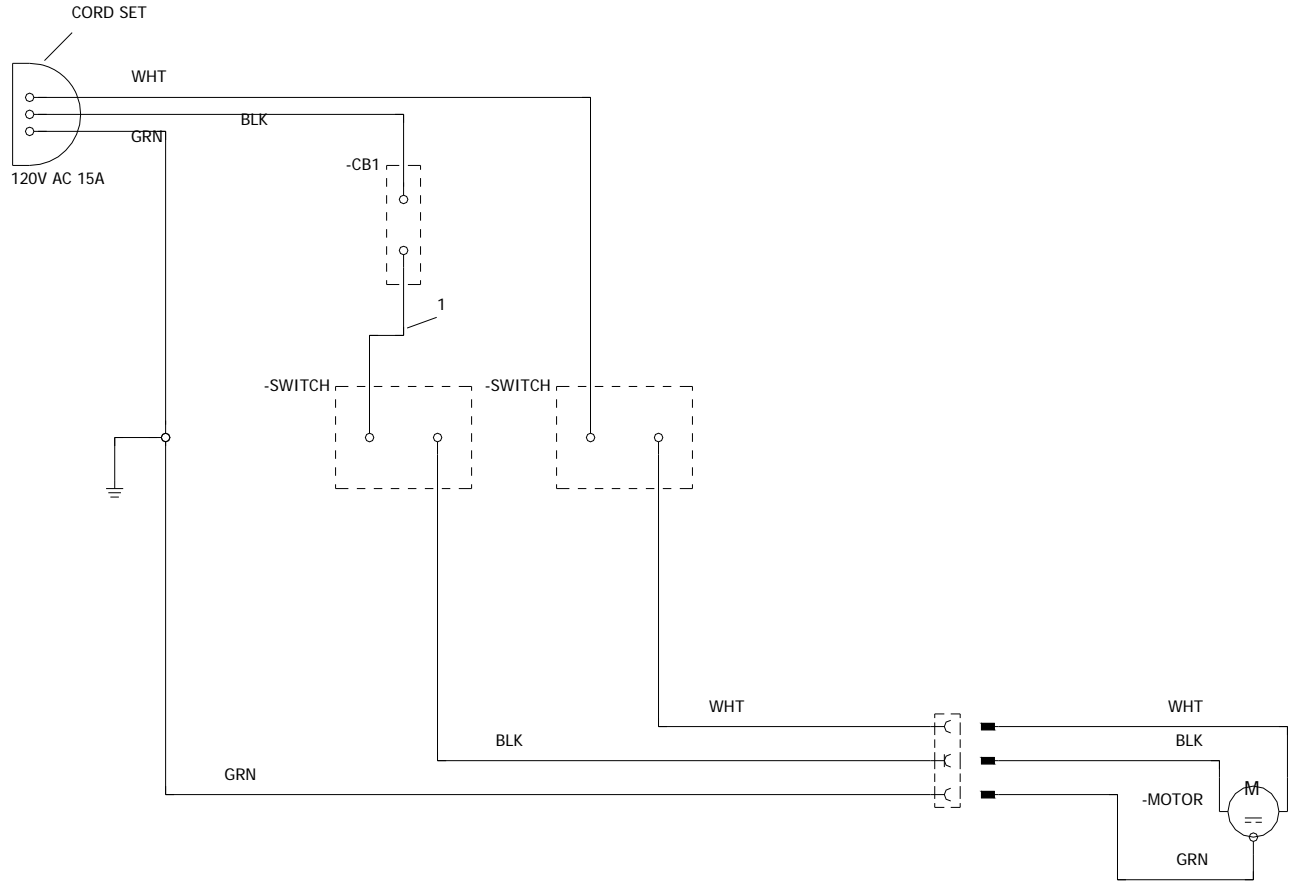

REF	PART NO.	QTY	DESCRIPTION	SERIAL NO. FROM	NOTES:
1	86311830	1	WIRE, 125MM, BLK/14, 76029X76029		

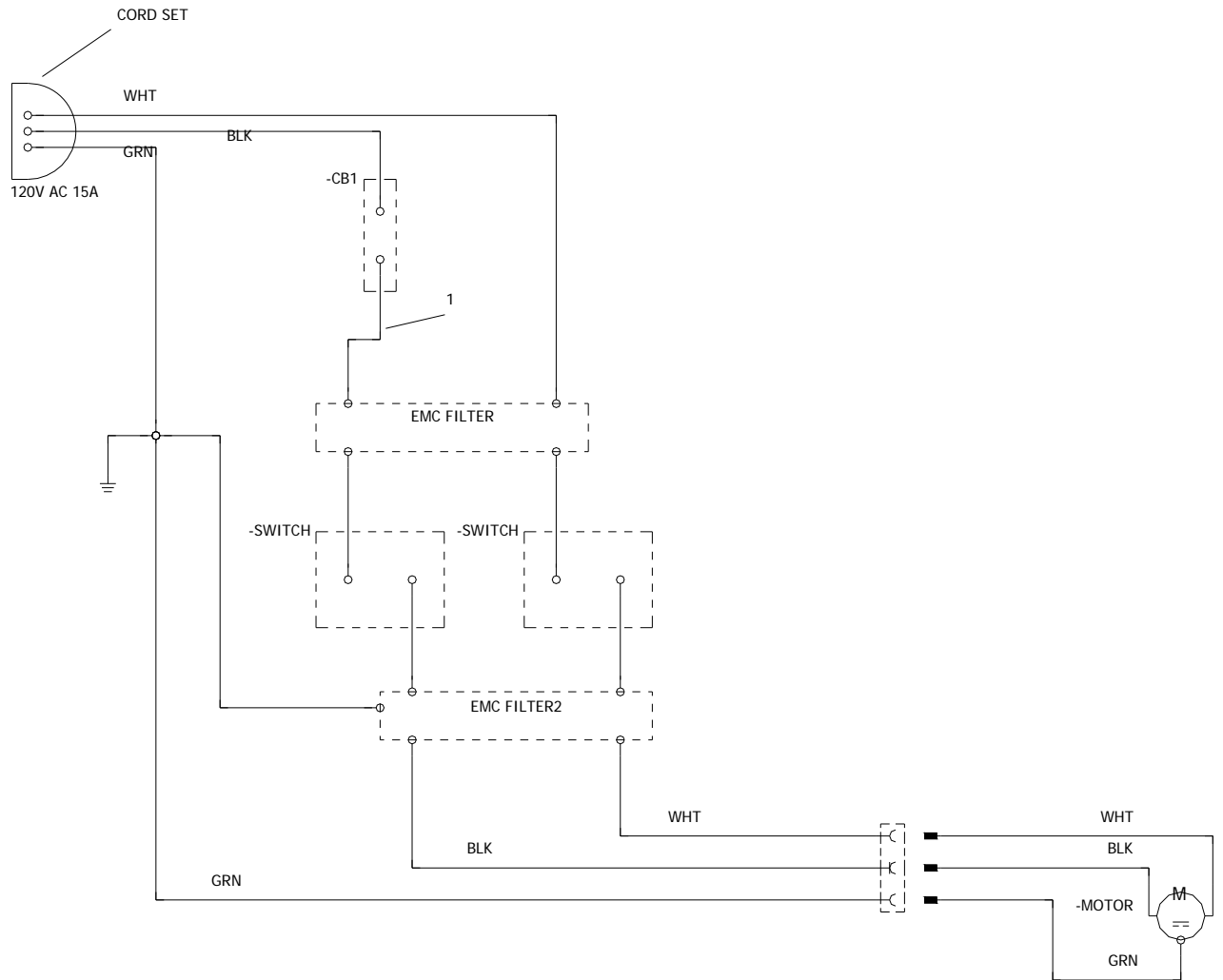

REF	PART NO.	QTY	DESCRIPTION	SERIAL NO. FROM	NOTES:
1	86311830	1	WIRE, 125MM, BLK/14, 76029X76029		

Serial Number

REF. NO.	MODEL: SERIAL #
1	**

