



Electronic Service Manuals

This electronic document is provided as a service to our customers. We do not create the contents of the information contained in this document. Should you have detailed questions pertaining to the information contained in this document, you may contact Michco, or the manufacturer which provided the original information in this electronic deliverable. Michco's only part in this electronic deliverable was the electronic assembly process. By providing this manual on line we are not guaranteeing parts availability.

You may contact Michco through the following methods:

Phone (517) 484-9312 or (800) 331-3339

2011 N. High St. -- Lansing, Michigan -- 48906

Fax: (517) 484-9836

Email: CustServe@Michco.com

Web site: www.Michco.Com

Parts Web site: www.FloorMachineParts.Com

Order Parts on Line at:

www.FloorMachineParts.Com

Directly to Parts & Service:

By Email: **Shop@Michco.com**

By Fax: (517) 702-2041

By Voice: Use numbers above.

Serving the Cleaning Industry Since 1922

Notice: All copyrighted material remains property of original owners, all trademarks are property of respective owners. Manuals are subject to Manufacturer's reproduction limitations. Originals or reproductions were provided by manufacturers through a request. We make no warranty as to the correctness of information provided in this document and you assume all risk. By placing these manuals on line we are not declaring our corporation to be an manufacturer authorized dealer or provider, please check our web site for authorized manufacturers we represent.

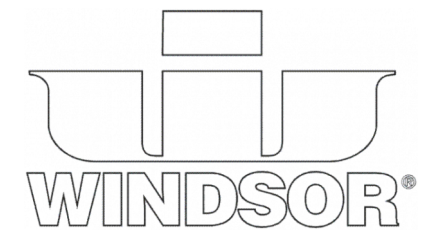

Spare parts list
(5.970-979.0) Spare parts list Saber Blade 16

Table of contents

Spare parts list Saber Blade 16 (5.970-979.0)	3
10 Retaining bracket and switch (0.201-287.0).....	4
11 Retaining bracket (0.201-288.0).....	5
12 Switch (0.201-289.0).....	7
20 Top part (0.201-291.0).....	9
21 Tank (0.201-290.0).....	10
22 Individual parts (0.201-292.0).....	12
30 Bottom part individual parts (0.201-293.0).....	15
31 Brush housing (0.201-294.0).....	16
32 Transmission (0.201-295.0).....	19
40 Chassis (0.201-279.0).....	22
50 Accessories pad roll (0.162-883.0).....	24

Spare parts list Saber Blade 16 (5.970-979.0)

Pos	Material #	Name	Qty.	Unit
10	0.201-287.0	Retaining bracket and switch	1.000	ST
20	0.201-291.0	Top part	1.000	ST
30	0.201-293.0	Bottom part individual parts	1.000	ST
40	0.201-279.0	Chassis	1.000	ST
50	0.162-883.0	Accessories pad roll	1.000	ST

10 Retaining bracket and switch (0.201-287.0)

Pos	Material #	Name	Qty.	Unit
11	0.201-288.0	Retaining bracket	1.000	ST
12	0.201-289.0	Switch	1.000	ST

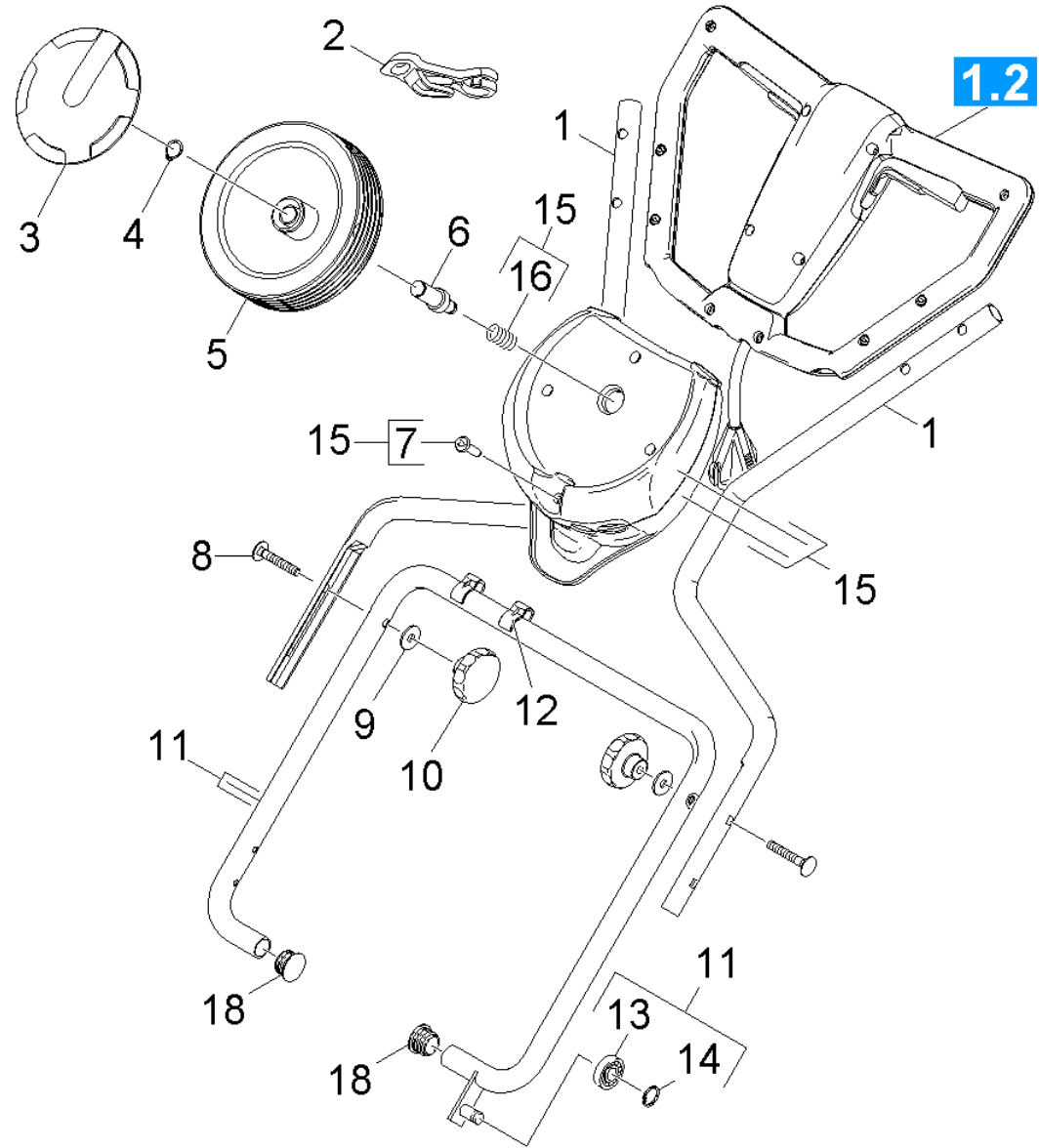

11 Retaining bracket (0.201-288.0)

ET/VT (spare/wear parts)	Pos	Material #	Name	Qty.	Unit
	1	5.034-783.0	Retaining bracket top part	2.000	ST
	2	6.641-776.0	Strain relief	1.000	ST
	3	6.435-349.0	Wheel cap black neutrally	2.000	ST
X-X	4	7.343-005.0	Locking ring 16x1-FST-PHR DIN 471	2.000	ST
X-X	5	6.435-196.0	Wheel D 180	2.000	ST
	6	5.034-795.0	Axle feed wheel	2.000	ST
X-X	7	7.303-108.0	Screw 5x20 -10.9-R2R (In6Rd)	4.000	ST
	8	7.303-009.0	Saucer-head screw M8x50-8.8-A2E DIN 603	2.000	ST
	9	7.312-277.0	Washer 8-200HV-A2E ISO7093-1	2.000	ST
	10	6.321-224.0	Turning knob grey D55mm	2.000	ST
	11	4.034-201.0	Retaining bracket bottom part replacemen	1.000	ST
X	12	5.050-426.0	Cable clip D22	2.000	ST
X	13	7.401-149.0	Ball bearing 608-2RS -Wälzl.St DIN 625	1.000	ST
	14	7.343-300.0	Lock washer 7-A2 DIN 6799	1.000	ST
	15	4.783-003.0	Set wheel vat	1.000	ST
	16	5.332-981.0	Pressure spring	2.000	ST
	18	6.368-173.0	Drain plug	2.000	ST

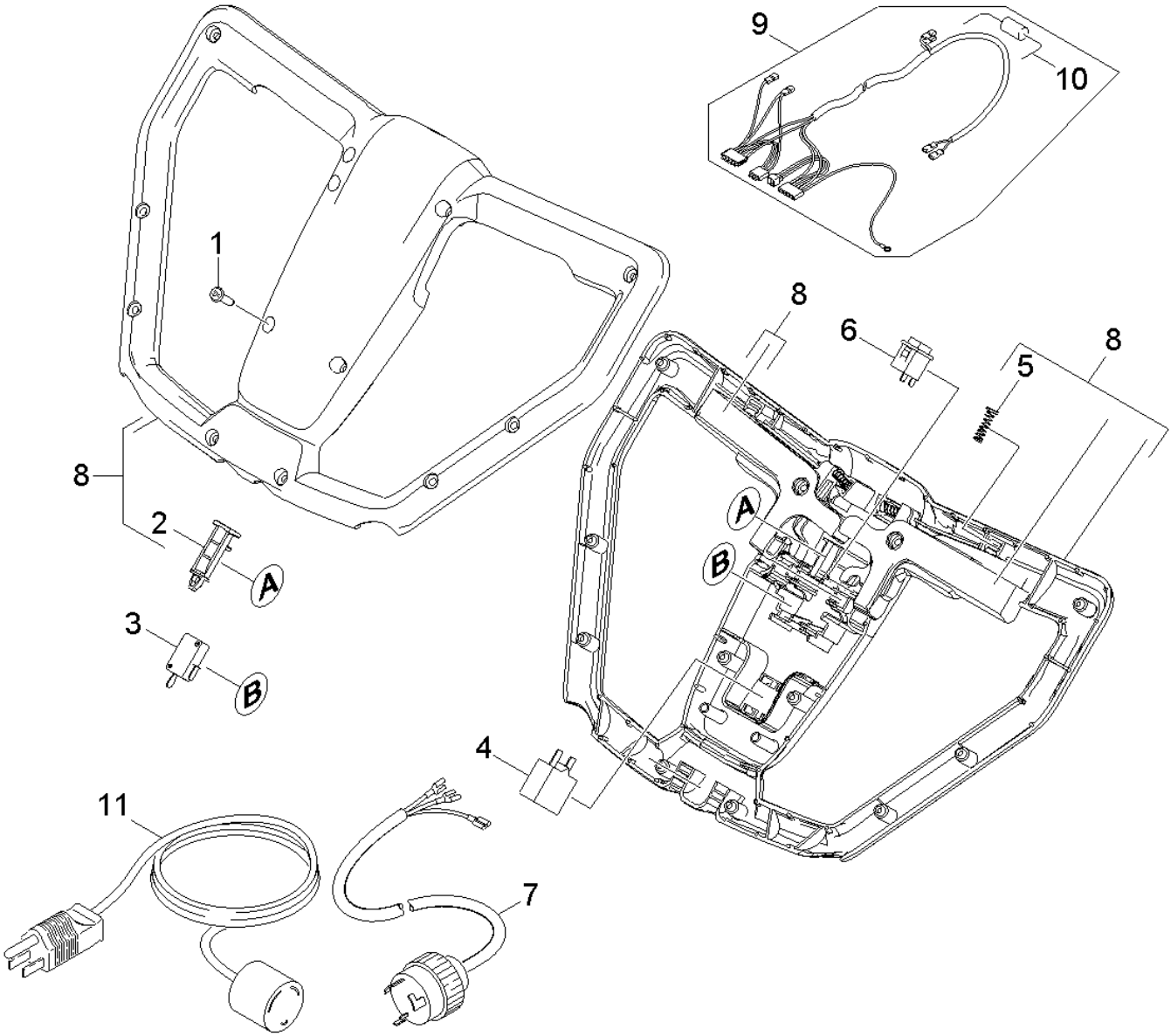

12 Switch (0.201-289.0)

ET/VT (spare/wear parts)	Pos	Material #	Name	Qty.	Unit
X-X	1	7.303-108.0	Screw 5x20 -10.9-R2R (In6Rd)	12.000	ST
	2	5.050-433.0	Slide of a press switch	1.000	ST
X-X	3	6.630-426.0	Main switch	2.000	ST
	4	6.630-428.0	Motor protecting switch 9A	1.000	ST
X-X	5	5.332-944.0	Spring conical	5.000	ST
X	6	6.630-427.0	Switch water pump	2.000	ST
X	7	6.649-696.0	Power cable SaberBlade 16	1.000	ST
	8	4.783-007.0	Set operating unit replacement	1.000	ST
X	9	6.649-685.0	Cable harness BR 40/10C KNA	1.000	ST
X	10	6.664-059.0	Diode Typ EM 513	1.000	ST
	11	8.623-411.0	CORD SET,14/3 SJTW-A X 50' YLW	1.000	ST

20 Top part (0.201-291.0)

Pos	Material #	Name	Qty.	Unit
21	0.201-290.0	Tank	1.000	ST
22	0.201-292.0	Individual parts	1.000	ST

21 Tank (0.201-290.0)

ET/VT (spare/wear parts)	Pos	Material #	Name	Qty.	Unit	Footnote text
X-X	1	5.050-732.0	Cover metering fresh water	1.000	ST	
X-X	2	4.783-006.0	Tank replacement	1.000	ST	
X	3	4.033-753.0	Valve tank completely	1.000	ST	
	4	6.388-216.0	Hose DN 5	1.000	M	TO ORDER AS CUT GOODS
X	5	5.731-664.0	Filter with weight	1.000	ST	
X-X	6	5.051-263.0	Closure tank	2.000	ST	
X	7	5.050-314.0	Carrier handle tank	2.000	ST	
X-X	8	5.034-868.0	Joint ring	1.000	ST	
X-X	9	6.362-108.0	O-Ring seal 30,0 X 3,0	2.000	ST	
	10	5.050-457.0	Suction tube waste water tank	2.000	ST	
X-X	11	6.273-282.0	Profile gasket 8,4x7	1.000	M	TO ORDER AS CUT GOODS
	12	5.050-401.0	Elbow float	1.000	ST	
X-X	13	5.585-060.0	Float BR 40/10	1.000	ST	
	14	4.034-198.0	Tank waste water blue	1.000	ST	
X-X	15	5.050-541.0	Form seal valve	1.000	ST	
X-X	16	7.312-014.0	Washer 10-A4 ISO 7090	1.000	ST	ORDER ACCORDING TO CONSUMPTION
	17	5.099-933.0	Washer	1.000	ST	
	18	7.303-243.0	Screw 4x8 -A2-70 (K-IN6RD)	1.000	ST	

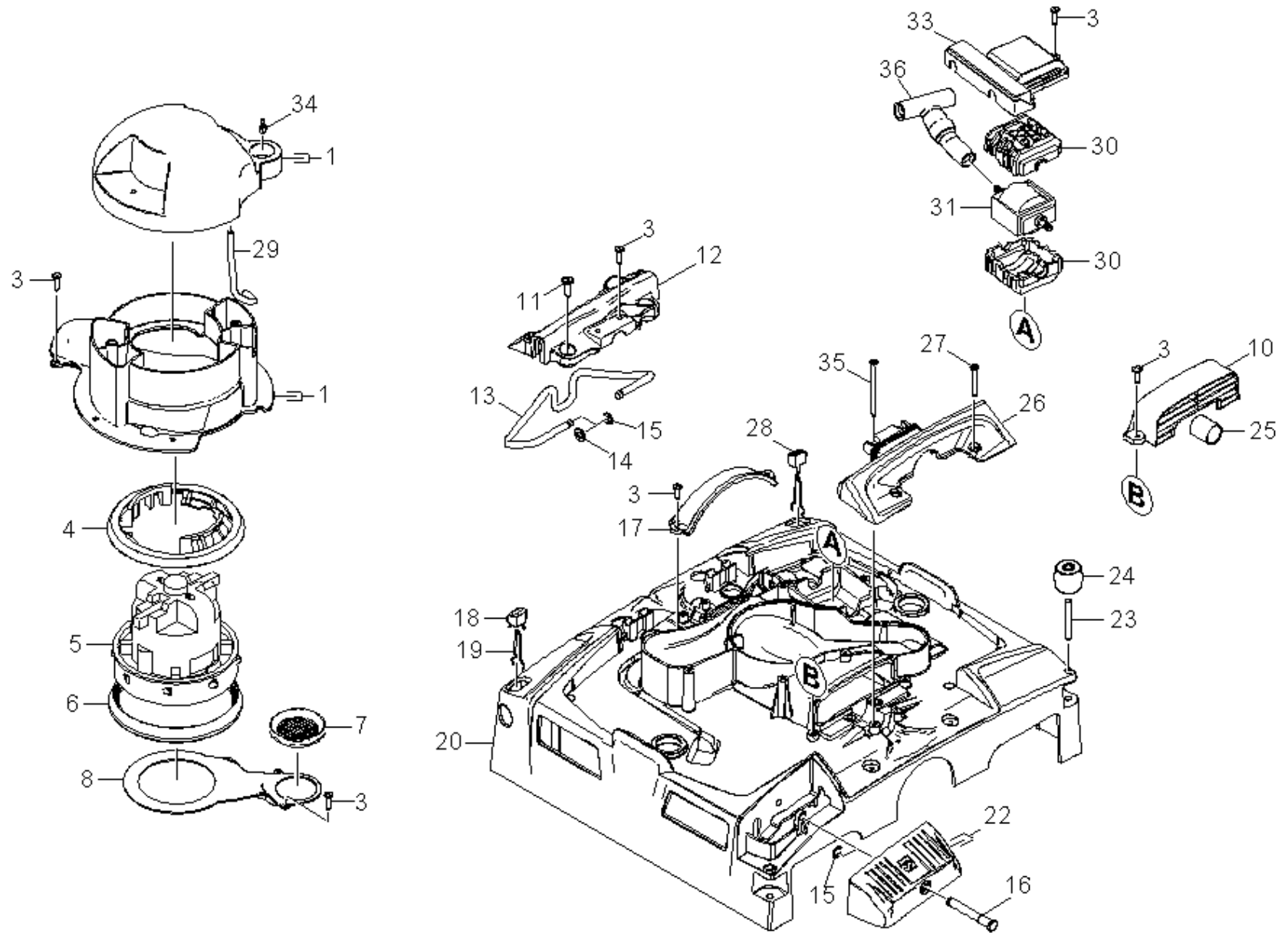

22 Individual parts (0.201-292.0)

ET/VT (spare/wear parts)	Pos	Material #	Name	Qty.	Unit	Footnote text
X-X	1	4.033-327.0	Set Housing Valve	1.000	ST	
X-X	3	7.303-108.0	Screw 5x20 -10.9-R2R (In6Rd)	18.000	ST	
	4	5.050-362.0	Seal above vac motor	1.000	ST	
	5	6.681-134.0	Set turbine replacement BR 40/10 100V-12	1.000	ST	
X	6	5.050-363.0	Seal bottom vac motor	1.000	ST	
X-X	7	5.363-344.0	Joint ring	1.000	ST	
	8	5.050-449.0	Covering cap vacuum channel	1.000	ST	
X-X	9	7.303-107.0	Screw 5x16 -10.9-P2R (K-In6Rd)	4.000	ST	
	10	5.050-407.0	Splash guard right	1.000	ST	
	11	7.303-067.0	Screw M8x16-ST-A3R (IN6RD)	4.000	ST	
	12	5.050-413.0	Retaining bracket fixing left	1.000	ST	
	13	5.034-827.0	Retaining bracket adjustment	1.000	ST	
X-X	14	7.312-017.0	Washer 8-A2 ISO 7089	2.000	ST	
	15	7.343-300.0	Lock washer 7-A2 DIN 6799	3.000	ST	
	16	5.034-786.0	Bolt pedal	1.000	ST	
	17	5.050-406.0	Splash guard left	1.000	ST	
	18	5.050-728.0	Pusher rear grey	1.000	ST	
	19	5.034-839.0	Spring feed wheel	2.000	ST	
	20	5.050-308.0	Cover brush housing	1.000	ST	
	22	4.783-008.0	Set pedal replacement	1.000	ST	
	23	5.034-847.0	Bolt deflector roll	2.000	ST	
	24	5.050-405.0	Deflector roll	2.000	ST	
	25	6.034-003.0	Bush plain bearing	2.000	ST	
	26	5.050-414.0	Retaining bracket fixing right	1.000	ST	
	27	7.303-111.0	Screw 5x50 -10.9-R2R (K-In6Rd)	4.000	ST	

22 Individual parts (0.201-292.0)

ET/VT (spare/wear parts)	Pos	Material #	Name	Qty.	Unit	Footnote text
	28	5.050-726.0	Pusher front feed wheel grau	1.000	ST	
	29	6.388-216.0	Hose DN 5	1.000	M	TO ORDER AS CUT GOODS
	30	5.050-408.0	Bearing pump	2.000	ST	
X-X	31	6.473-532.0	Motor pump 120V 60Hz	1.000	ST	
	33	5.050-410.0	Cover pump	1.000	ST	
X-X	34	5.108-192.0	Pin valve	1.000	ST	
	35	7.303-171.0	Screw 5x80 -10.9-R2R (K-In6Rd)	2.000	ST	
X	36	4.050-956.0	Check valve	1.000	ST	

30 Bottom part individual parts (0.201-293.0)

Pos	Material #	Name	Qty.	Unit
31	0.201-294.0	Brush housing	1.000	ST
32	0.201-295.0	Transmission	1.000	ST

31 Brush housing (0.201-294.0)

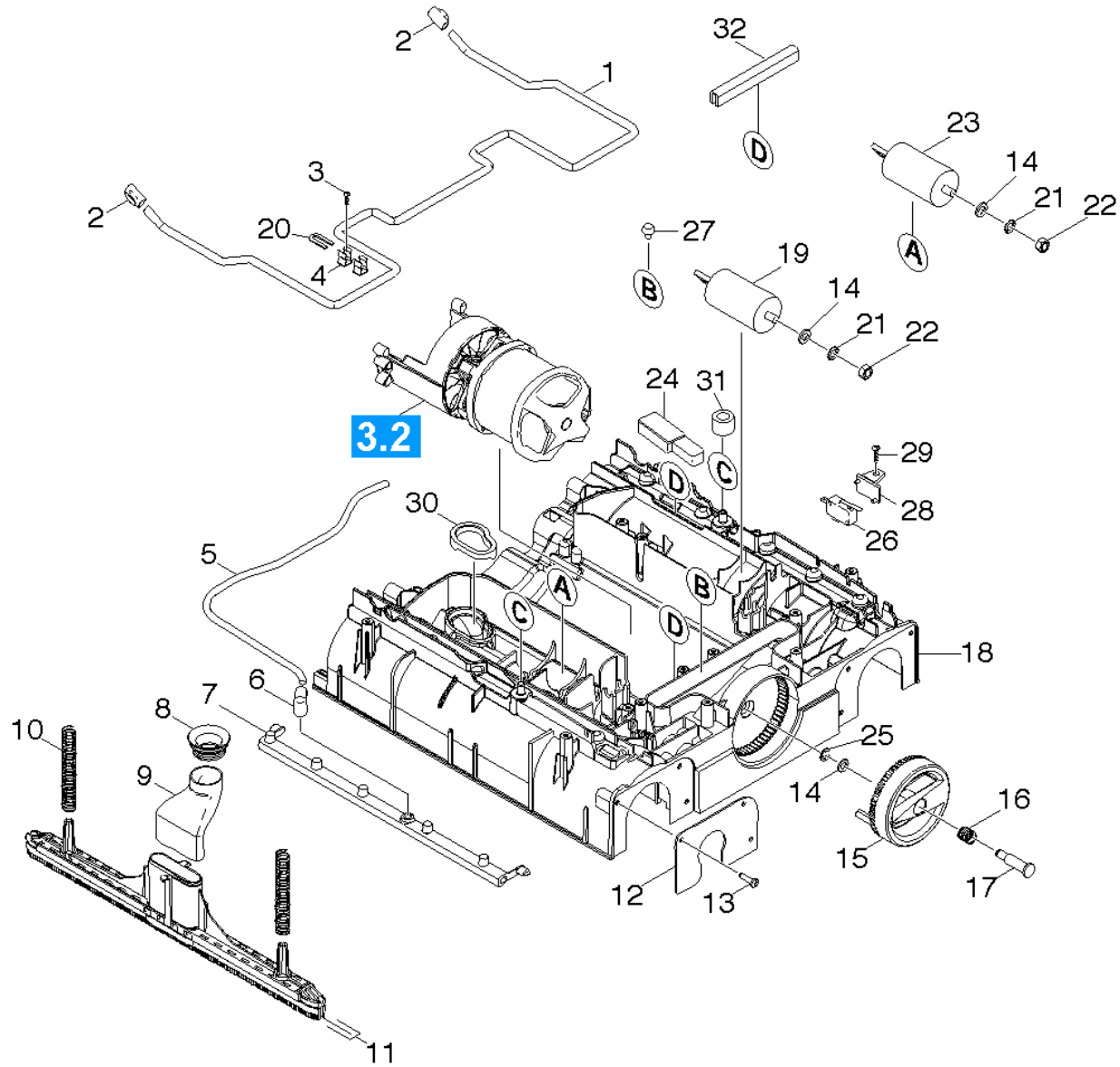

31 Brush housing (0.201-294.0)

ET/VT (spare/wear parts)	Pos	Material #	Name	Qty.	Unit	Footnote text
	1	5.034-784.0	Retaining bracket suction bar	1.000	ST	
	2	5.050-729.0	Pusher suction bar grey	2.000	ST	
	3	7.303-092.0	Screw 3x12 -10.9-R2R (K-In6Rd)	2.000	ST	
	4	6.330-410.0	Spring clip X130-8L	2.000	ST	
	5	6.388-216.0	Hose DN 5	1.000	M	TO ORDER AS CUT GOODS
	6	5.050-411.0	Angle bushing water distributor	2.000	ST	
	7	5.050-409.0	Water distributor	2.000	ST	
X-X	8	5.050-415.0	Joint ring	2.000	ST	
	9	5.050-404.0	Joining piece suction bar	2.000	ST	
X-X	10	5.332-216.0	Helical spring	4.000	ST	
X-X	11	4.777-322.0	Suction bar oil resistant complete	2.000	ST	OIL RESISTANT
X-X	11	4.777-323.0	Suction bar complete replacement	2.000	ST	
	12	5.034-799.0	Plate brush holder	2.000	ST	
X-X	13	7.303-212.0	Screw 5x20 -A2-70 (In6Rd)	6.000	ST	
X-X	14	7.312-004.0	Washer 8 -200HV-A3E ISO 7090	3.000	ST	
	15	5.050-748.0	Handle grey	1.000	ST	
	16	5.332-207.0	Helical spring	1.000	ST	
	17	5.034-929.0	Bolt carriage	1.000	ST	
	18	4.033-326.0	Brush housing replacement	1.000	ST	
	19	6.661-221.0	Capacitor	1.000	ST	
	20	5.034-873.0	Plate reinforcement	1.000	ST	
	21	7.312-233.0	Serrated lock washer A8,4-FSt-A3E DIN67	2.000	ST	
X-X	22	7.311-004.0	Hexagon nut M8 -8-A3E ISO 4032	2.000	ST	
	23	6.661-220.0	Capacitor	1.000	ST	
	24	6.682-975.0	Starting electronic MAS (d) 100-120V	1.000	ST	

31 Brush housing (0.201-294.0)

ET/VT (spare/wear parts)	Pos	Material #	Name	Qty.	Unit	Footnote text
	25	7.343-300.0	Lock washer 7-A2 DIN 6799	1.000	ST	
X-X	26	6.630-438.0	Micro switch	1.000	ST	
	27	6.339-249.0	Rubber buffer motor	2.000	ST	
	28	5.050-654.0	Retainer micro switch	1.000	ST	
X-X	29	7.303-108.0	Screw 5x20 -10.9-R2R (In6Rd)	1.000	ST	
	30	5.050-572.0	Seal exhaust air	1.000	ST	
X-X	31	5.034-894.0	Joint ring	2.000	ST	
X-X	32	6.273-055.0	Profile gasket	2.000	M	TO ORDER AS CUT GOODS

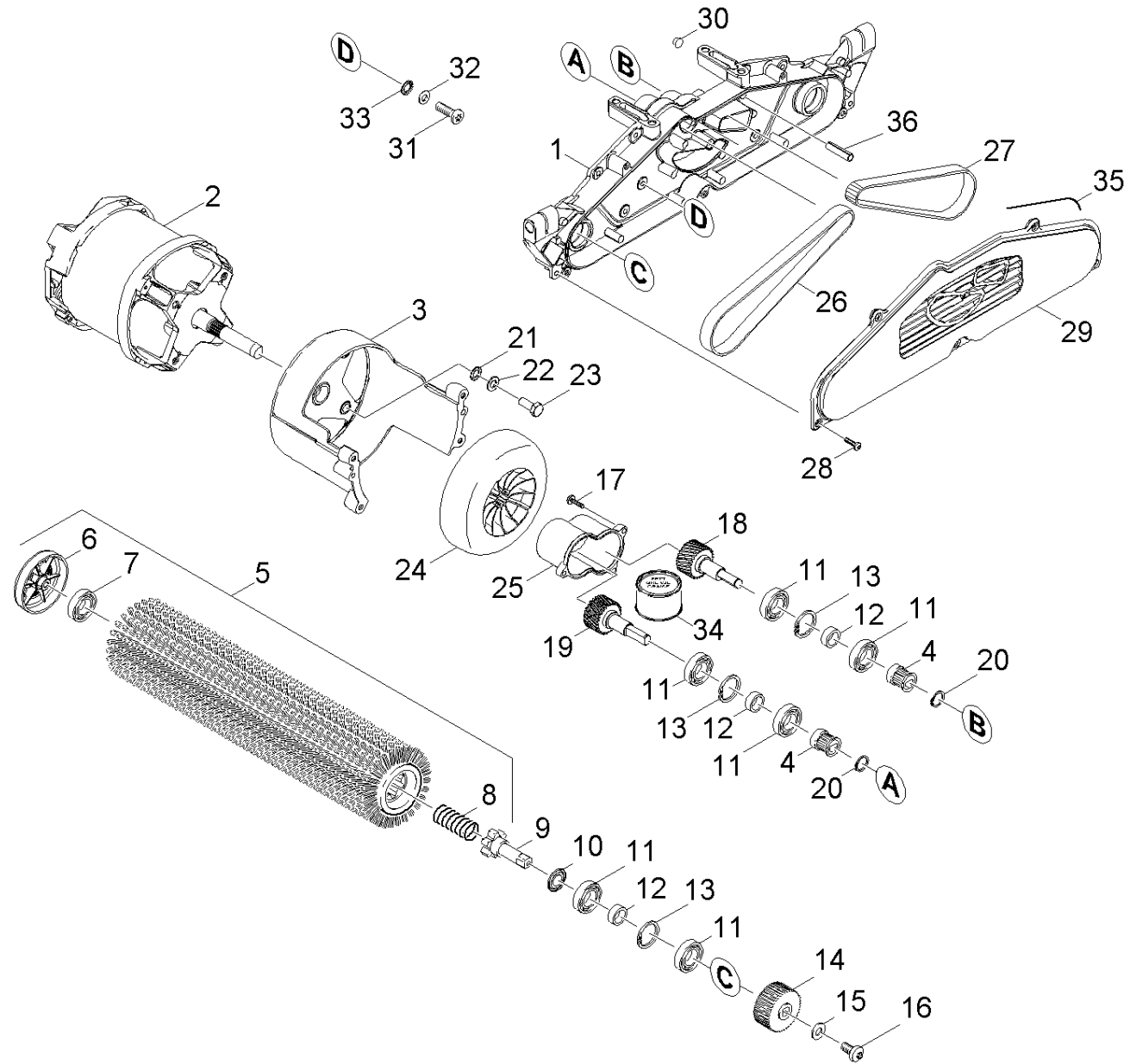

32 Transmission (0.201-295.0)

ET/VT (spare/wear parts)	Pos	Material #	Name	Qty.	Unit	var. information	Footnote text
	1	5.050-445.0	Gear case worked	1.000	ST		
	2	6.680-000.0	Electric motor 1,1 kW 120 V	1.000	ST		
	3	5.050-432.0	Flange motor worked	1.000	ST		
X-X	4	5.625-318.0	Belt pulley 21Z	2.000	ST		
X-X	5	4.762-251.0	Roller brush orange (old colour red)	2.000	ST		
X-X	5	4.762-481.0	Roller brush black complete	2.000	ST		
X-X	5	4.762-250.0	Roller brush white (old colour black)	2.000	ST		
X-X	5	4.762-252.0	Roller brush green (old colour grey)	2.000	ST		
X-X	5	4.762-274.0	Roller brush horsehair nature BR VS 400	2.000	ST		
X-X	5	4.762-458.0	Roller brush red complete	2.000	ST		
X-X	6	4.038-677.0	Sheet metal component thread deflector	2.000	ST		
X-X	7	6.401-363.0	Ball bearing	2.000	ST		
X-X	8	5.332-114.0	Helical spring	2.000	ST		
X	9	5.100-571.0	Driveshaft 59mm	2.000	ST		
X-X	10	6.363-292.0	Joint ring NILOS 6002	2.000	ST		
X-X	11	7.401-115.0	Ball bearing 6002-2RS -WÄELZLAGST DIN 62	8.000	ST		
X-X	12	5.110-686.0	Spacer sleeve	4.000	ST		
X-X	13	7.343-231.0	Locking ring 32x1,2 -St-ph DIN 472	4.000	ST		
X-X	14	5.625-357.0	Belt pulley 56Z HTD 3M	2.000	ST		
X-X	15	7.312-292.0	Washer 6 -A2 ISO 7093-1	2.000	ST		
X-X	16	7.306-192.0	Screw M 6x 12-A2-70 (In6Rd)	2.000	ST		
	17	7.303-039.0	Screw M5x16 -St-A2R (In6Rd)	3.000	ST		
X-X	18	4.100-125.0	Shaft gear left BR VS	1.000	ST		
X-X	19	4.100-234.0	Shaft gear right	1.000	ST		
X-X	20	7.343-003.0	Locking ring 12x1-Rf-St DIN 471	2.000	ST		

32 Transmission (0.201-295.0)

ET/VT (spare/wear parts)	Pos	Material #	Name	Qty.	Unit	var. information	Footnote text
	21	7.312-233.0	Serrated lock washer A8,4-FSt-A3E DIN67	4.000	ST		
X-X	22	7.312-017.0	Washer 8-A2 ISO 7089	4.000	ST		
X-X	23	7.304-397.0	Hexagonal head screw M8x20-8.8-A2E ISO	4.000	ST		
X	24	5.050-358.0	Blower wheel	1.000	ST		
	25	5.050-357.0	Cover gear	1.000	ST		
X-X	26	6.348-444.0	Toothed belt HTD-420-3M-15 CXPIII	1.000	ST		
X-X	27	6.348-431.0	Toothed belt HTD-474-3M-15 CXPIII	1.000	ST		
X-X	28	7.303-108.0	Screw 5x20 -10.9-R2R (In6Rd)	6.000	ST		
	29	5.050-310.0	Cover gear case	1.000	ST		
	30	6.368-347.0	Cap D5	1.000	ST		
X-X	31	7.306-105.0	Screw M6x30 -8.8-R3R (In6Rd)	4.000	ST		
X-X	32	7.312-003.0	Washer 6 -200HV-A3E ISO 7090	1.000	ST		
	33	7.312-232.0	Serrated lock washer A6,4-FSt-A3E DIN 6	4.000	ST		
	34	6.288-095.0	Viscous oil	1.000	ST	50g	
	35	6.273-037.0	Seal string cellular rubber 3	1.000	M		TO ORDER AS CUT GOODS
	36	7.314-944.0	Spring pin 5x24-St ISO 8752	2.000	ST		

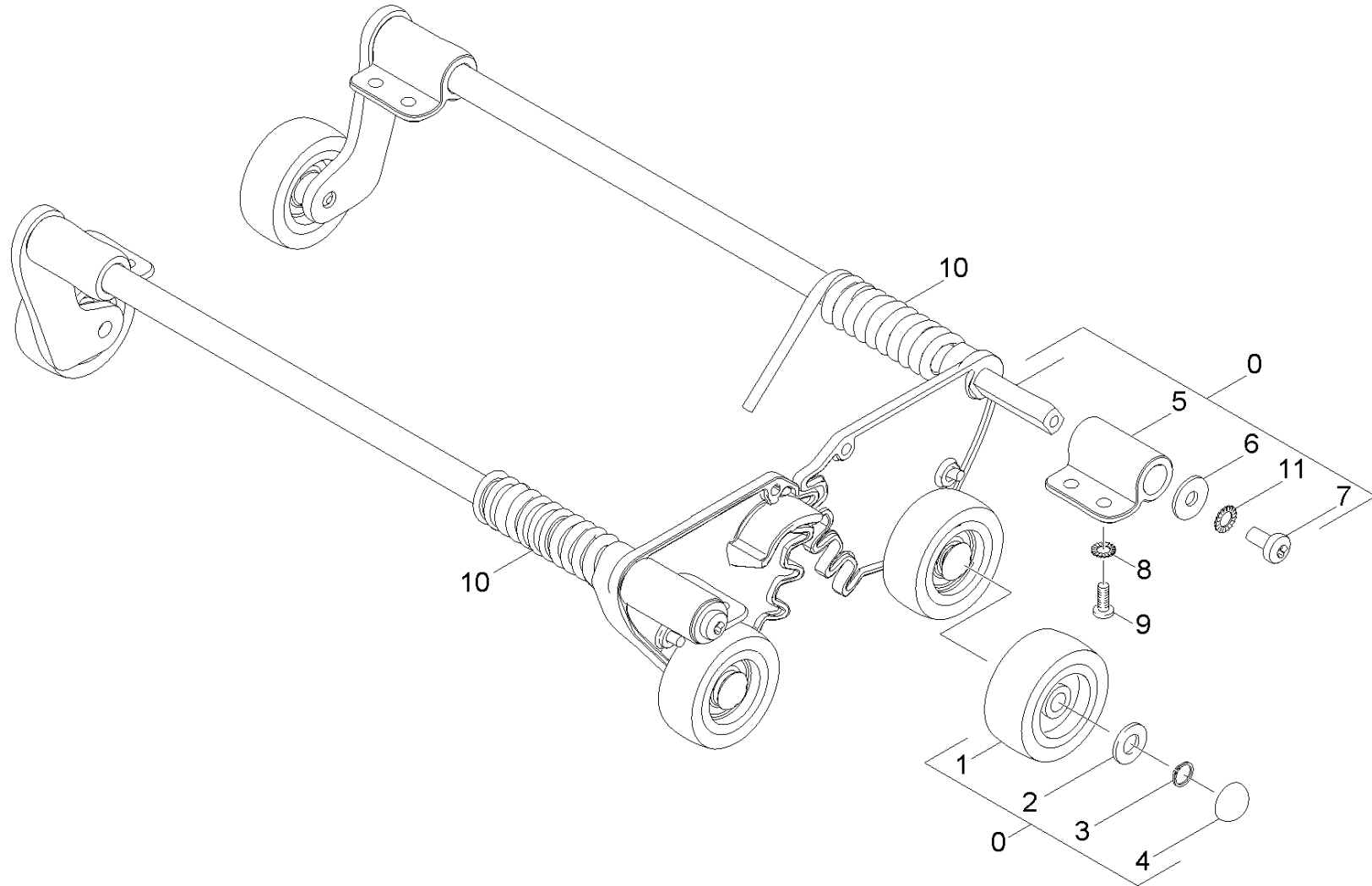

40 Chassis (0.201-279.0)

ET/VT (spare/wear parts)	Pos	Material #	Name	Qty.	Unit
	0	3.034-008.0	Carriage complete	1.000	ST
X-X	1	6.435-373.0	Wheel traceless grey D50	4.000	ST
X	2	7.362-002.0	Joint ring A8x11,5 -Cu DIN 7603	4.000	ST
X	3	7.343-127.0	Locking ring 8x0,8 -Rf-St DIN 471	4.000	ST
	4	6.343-132.0	Lock washer 8	4.000	ST
X-X	5	5.050-397.0	Bearing flange carriage	4.000	ST
X-X	6	7.312-292.0	Washer 6 -A2 ISO 7093-1	4.000	ST
X-X	7	7.306-192.0	Screw M 6x 12-A2-70 (In6Rd)	4.000	ST
X-X	8	7.312-041.0	Serrated lock washer A5,3-1.4310 DIN 67	8.000	ST
X-X	9	7.303-212.0	Screw 5x20 -A2-70 (In6Rd)	8.000	ST
	10	4.034-179.0	Leg spring set	1.000	ST
X-X	11	7.312-020.0	Serrated lock washer A6,4-1.4310 DIN679	4.000	ST

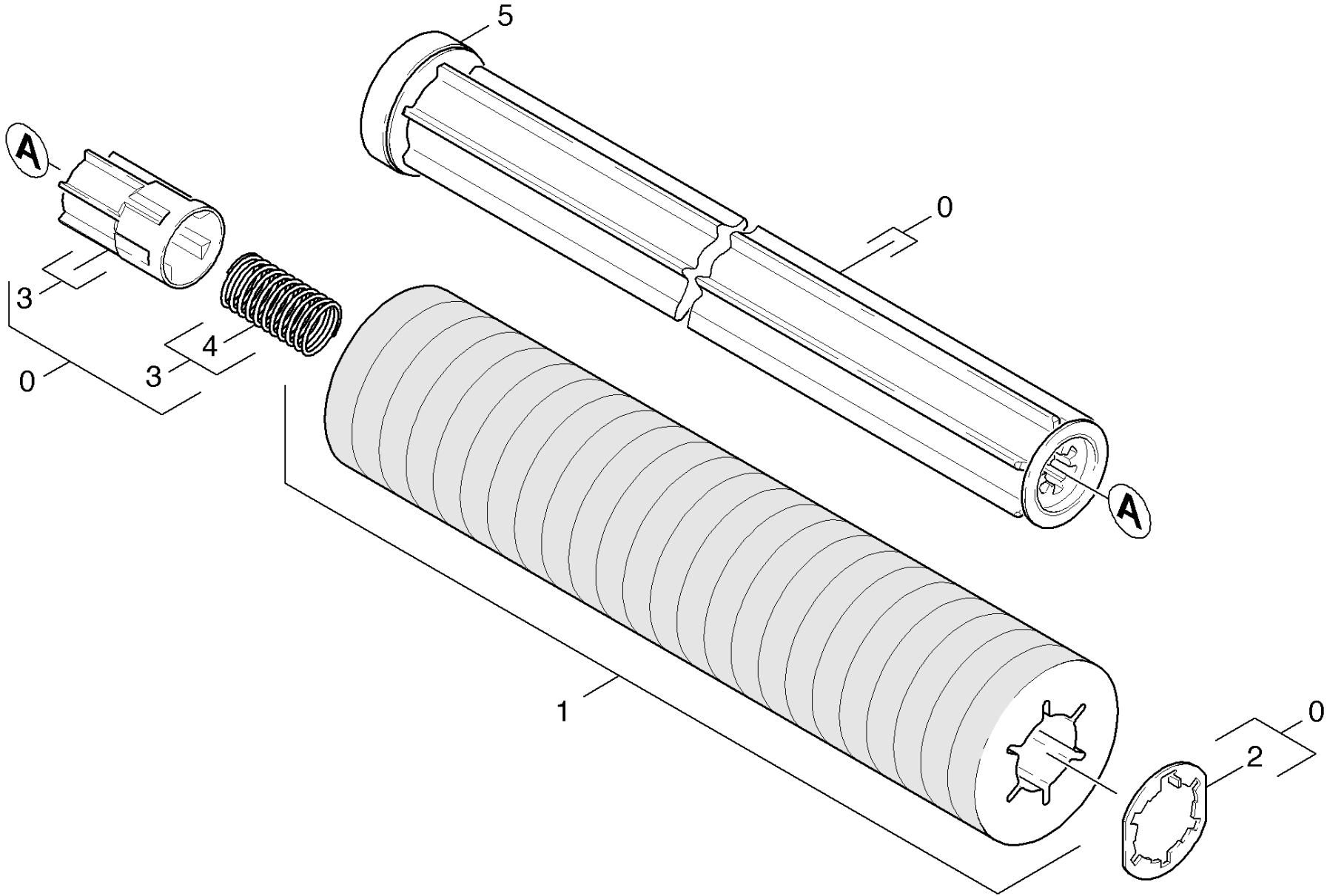

50 Accessories pad roll (0.162-883.0)

ET/VT (spare/wear parts)	Pos	Material #	Name	Qty.	Unit	from ser.nr.	up to ser.nr.
X-X	0	4.762-228.0	Roll Pad BR VS 400	1.000	ST	0000000000	0000000000
X-X	1	6.369-726.0	Pad red with sleeve	1.000	ZSA	0000000000	0000000000
	1	6.369-727.0	Pad white with sleeve BR VS 400	1.000	ZSA	0000000000	0000000000
X-X	1	6.369-724.0	Pad yellow with sleeve	1.000	ZSA	0000000000	0000000000
X-X	1	6.369-725.0	Pad green with sleeve	1.000	ZSA	0000000000	0000000000
	2	4.115-003.0	Washer closure	1.000	ST	0000000000	0000000000
	3	5.120-313.0	Hub pad roll BR VS	1.000	ST	0000000000	0000000000
	4	5.332-469.0	Helical spring	1.000	ST	0000000000	0000000000
X-X	5	4.038-677.0	Sheet metal component thread deflector	1.000	ST	0000000000	0000000000