



Electronic Service Manuals

This electronic document is provided as a service to our customers. We do not create the contents of the information contained in this document. Should you have detailed questions pertaining to the information contained in this document, you may contact Michco, or the manufacturer which provided the original information in this electronic deliverable. Michco's only part in this electronic deliverable was the electronic assembly process. By providing this manual on line we are not guaranteeing parts availability.

You may contact Michco through the following methods:

Phone (517) 484-9312 or (800) 331-3339

2011 N. High St. -- Lansing, Michigan -- 48906

Fax: (517) 484-9836

Email: CustServe@Michco.com

Web site: www.Michco.Com

Parts Web site: www.FloorMachineParts.Com

Order Parts on Line at:

www.FloorMachineParts.Com

Directly to Parts & Service:

By Email: **Shop@Michco.com**

By Fax: (517) 702-2041

By Voice: Use numbers above.

Serving the Cleaning Industry Since 1922

Notice: All copyrighted material remains property of original owners, all trademarks are property of respective owners. Manuals are subject to Manufacturer's reproduction limitations. Originals or reproductions were provided by manufacturers through a request. We make no warranty as to the correctness of information provided in this document and you assume all risk. By placing these manuals on line we are not declaring our corporation to be an manufacturer authorized dealer or provider, please check our web site for authorized manufacturers we represent.

3 - SPEED AIR MOVER

OWNERS MANUAL

IMPORTANT: READ OWNERS MANUAL CAREFULLY
Please fill out & return your warranty card !

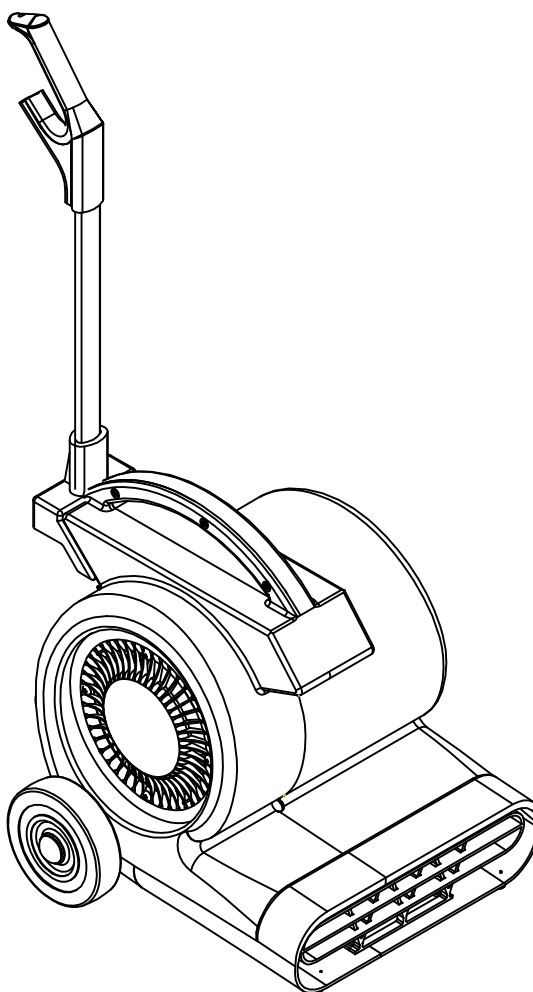

MODEL #

WT3SPD

REV.01(03-09)

30521U

TABLE OF CONTENTS

Safety Precautions	3
Machine Operation	4
Machine Maintenance & Storage	4
Parts List	5--- 9
Wiring Diagram	10

SAFETY PRECAUTIONS

!!! This machine must be grounded!

Grounding provides a path of least resistance for electrical current. To reduce the risk of electrical shock should the machine malfunction, the machine has a special grounding plug. Don't remove the ground pin under any circumstances!

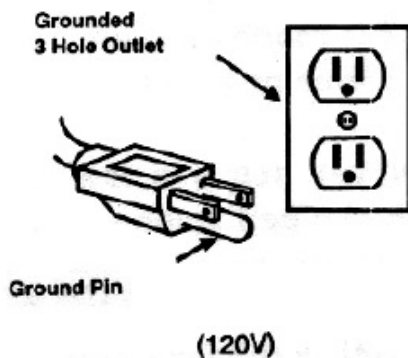

This machine is intended for commercial use. It is constructed for use in an indoor environment and is not intended for any other use. Use only recommended accessories.

All operators shall read, understand and exercise the following safety precautions:

1] Do not operate machine:

- Unless trained and authorized.
- Unless you have read and understand operators manual.
- In flammable or explosive areas.
- With a damaged cord or plug.
- If not in proper operating condition.
- In outdoor areas.

- In standing water
- With the use of extension cords.

2] Before operating machine:

- Make sure all safety devices are in place and operate properly.

3] When using machine:

- Do not run machine over cord.
- Do not pull machine by cord or plug
- Do not pull cord around sharp edges or corners.
- Do not unplug by pulling on the cord.
- Do not stretch cord.
- Do not handle plug with wet hands.
- Keep cord away from heated surfaces.
- Do not pick up burning or smoking debris such as cigarettes, matches or hot ashes.
- Report machine damage or faulty operation immediately.

4] Before leaving or servicing machine:

- Turn off machine.
- Unplug cord from outlet.

5] When servicing machine:

- Unplug cord from outlet.
- Use manufacturer supplied or approved replacements parts.

Operation of Air Mover

* **Read operators manual thoroughly prior to operating or servicing this machine.**

BASIC OPERATION

1] Check machine for any obstructions in fan prior to operation.

* If an item blocks the intakes of the blower, this will hurt the performance of the blower, and could cause the motor to overheat.

2] Adjust machine to desired position for operation by either pulling it back to it's preset height adjustments, or by lowering the "kick stand" and setting the machine on the stand.

3] Plug power cord into a grounded outlet.

* **Do not use an extension cord in conjunction with the standard power cord.**

4] This machine has three power settings Turn the power knob to the desired speed. Low = 1, Med = 2 & High = 3.

5] To stop the machine at any time, simply turn the power knob to the "off" position.

* **Never stick any object into the air inlet vents or the air outlet vent.**

MAINTENANCE

To keep the machine performing well for many years, please follow the following maintenance procedures.

* **Always confirm that the machine is unplugged prior to performing any maintenance or repairs.**

1] Unplug machine as soon as you are done using it.

2] Wrap the power cord around the carrying handle.

3] Check power cord for any damage. If any damage is detected, replace the cord immediately.

4] If you have the wheel kit, lubricate wheels with a water resistant lubricant every month.

5] Check machine for loose or missing nuts and bolts, and replace as necessary.

6] Clean the outside of the machine with a mild cleaner.

STORAGE

1] Unplug machine from power source.

2] Store in upright position in a dry area.

PARTS LIST

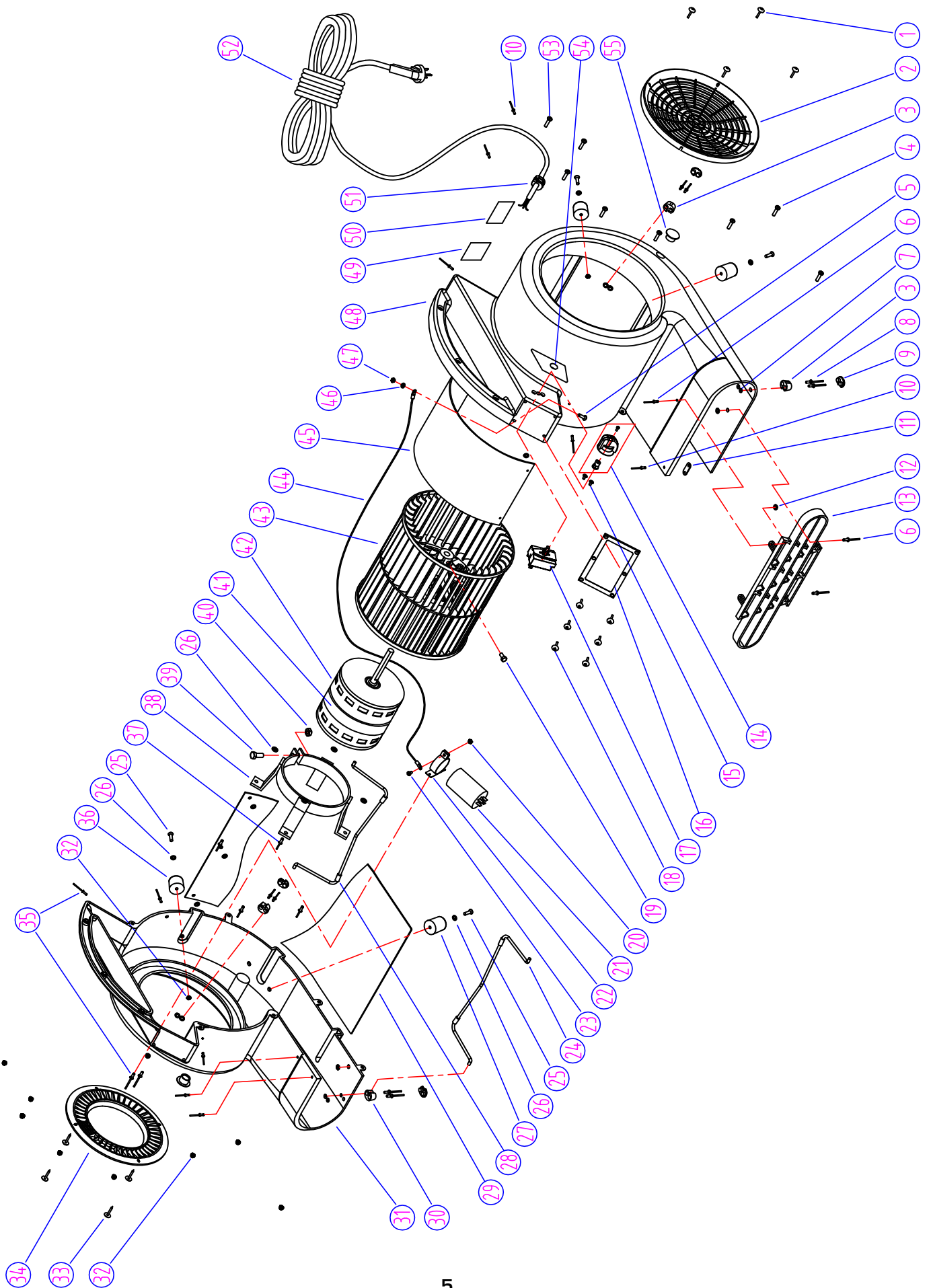

PARTS LIST

DIA NO	PART NUMBER	DESCRIPTION	NO REQ'D
1	VV13649	SCREW,SELF-TAPPING,ST,M4X25	4
2	VV30107	LEFT NET,VENT,INTAKE	1
3	VV30102	BLOCK,STAND,RIGHT FRONT	2
4	VF13613	SCREW,M5X20	8
5	VF14070	SCREW,M4X25	1
6	VV13647	RIVET,M4.8X18	4
7	VV13653	WASHER,PLAIN,M3.5XM10X1.0	15
8	VV13645	RIVET,M3.2X16	4
9	VV30124	RUBBER,BLOCK,STAND	2
10	VV20352	RIVET,M4X12	2
11	VV30119	CONNECTING PLATE	1
12	VA13482	WASHER,PLAIN,M5.0XM11X1.0	4
13	VV30112	NET,VENT,OUTLET	1
14	VV 30015	ROTATOR,SWITCH,KIT	1
15	VV13658	SCREW,SWITCH,M5X20	2
16	VV30103	PLATE	1
17	VV30180	SWITCH	1
18	VV13608A	SCREW,SELF-TAPPING,ST,M4X12	6
19	VV13656	SCREW,M8X16	1
20	VV13609	NUT,M4	1
21	VV30143	CAPACITOR,30UF/300V	1
22	VV30014	CLAMP,CAPACITOR	1
23	VV13642	SCREW,M4X8	1
24	VV30115	STAND	2
25	VA13475	SCREW,M5X25	4
26	VV13 662	WASHER,PLAIN,M5XM12X1.0	8
27	VV30114-1	RUBBER,STAND,38mm	2
28	VV30117	SLEEVE,RUBBER	2
29	VV30118	PLATE,CHAMBER	1
30	VV30200	BLOCK,STAND,LEFT FRONT	2
31	VV30100A	HOUSING,LEFT	1
32	GT13022	NUT,LOCK,M5	15

PARTS LIST

DIA NO	PART NUMBER	DESCRIPTION	NO REQ'D
33	VV13640	SCREW,SELF-TAPPING,ST,M4X16	4
34	VV30110	RIGHT NET,VENT,INTAKE	1
35	VV13655	RIVET,M3.2X12	9
36	VV30114	RUBBER,STAND,48mm	2
37	VV13648	RIVET,M6.4X18	4
38	VV30011	CLAMP,MOTOR	1
39	VV13657	SCREW,M8X25	1
40	VF13503	NUT,LOCK,M8	1
41	VV30116	GASKET,MOTOR	1
42	YQ61000	MOTOR,120V,3/4HP	1
43	VV30010	IMPELLER,9"	1
44	VA21570	CABLE,200mm	1
45	VV30118A	PLATE,CHAMBER	1
46	VF13527	WASHER,TOOTH,M4	3
47	VV20249	NUT,M4	4
48	VV30101A	HOUSING,RIGHT	1
49	VV30202	READ MANUAL,LABEL	1
50	VV30505U	SERIAL TAG	1
51	VV30182	POWER BUSHING	1
52	VV30183	POWER CORD	1
53	VV13636	SCREW,M5X30	3
54	VV30529	LABEL,SWITCH	1
55	VV30122	COVER,AXLE	2

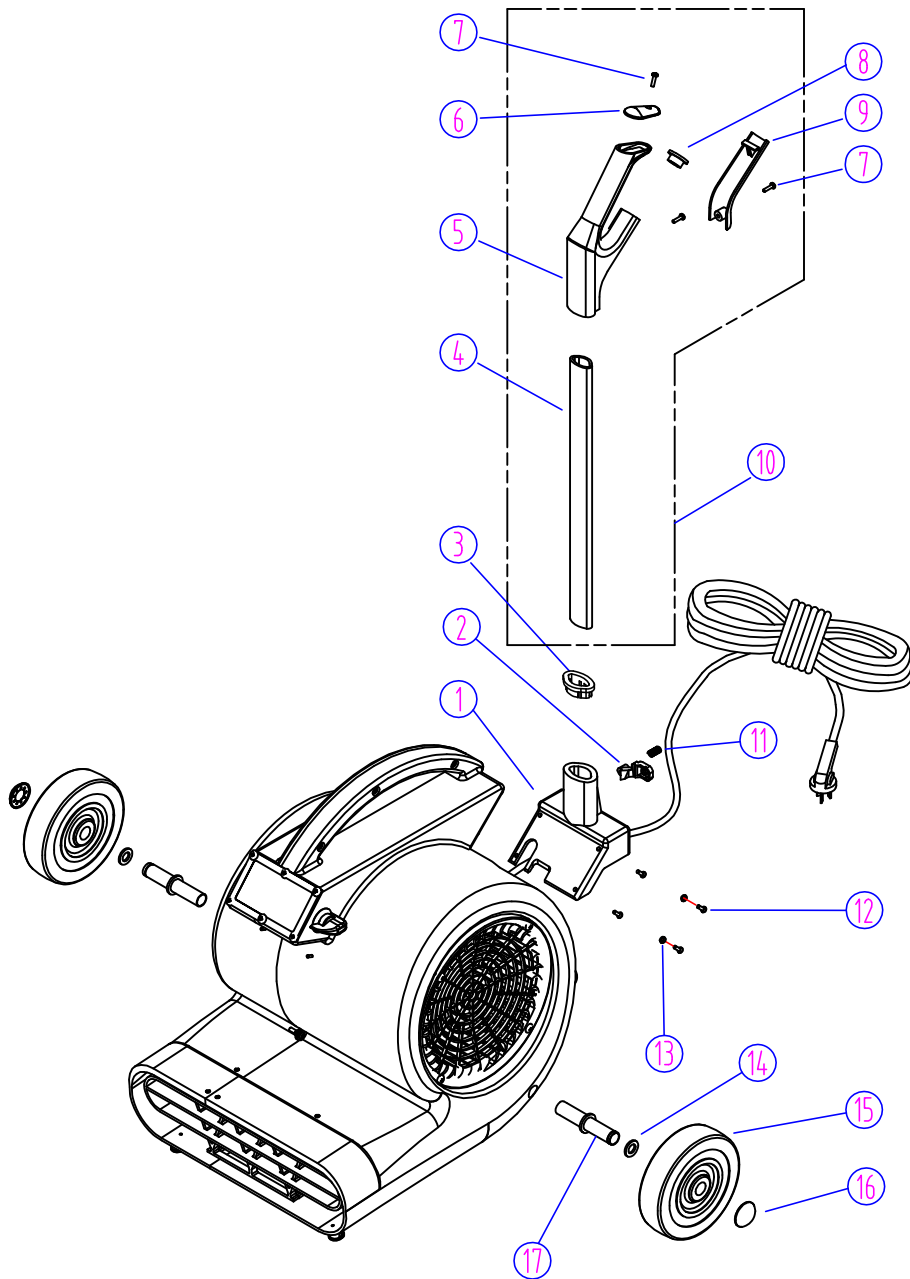

**THE AXLES HAVE A VERY TIGHT TOLERANCE FIT.
LUBRICATE THEM WITH SOME SOAPY WATER BEFORE
DRIVING THEM INTO THE MOLDED RECEIVER.**

PARTS LIST

DIA NO	PART NUMBER	DESCRIPTION	NO REQ'D
1	VV30120	SEAT,HANDLE	1
2	VV30130	RELEASE BUTTON	1
3	VV30121	COVER,HANDLE SEAT	1
4	VV30106A	TUBE,AL	1
5	VV30132	PLASTIC HANDLE	1
6	VV30134	COVER,HANDLE	1
7	VV13640	SCREW,SELF-TAPPING,ST,M4X16	3
8	VV30123	RUBBER COVER,HANDLE	1
9	VV30133	BOTTOM,HANDLE	1
10	VV30109B	HANDLE ASSEMBLY	1
11	VV30131	SPRING,RELEASE BUTTON	1
12	VV13661	SCREW,M4X12	4
13	VV13664	WASHER,PLAIN,M4XM12X1	4
14	VF47027	WASHER,LOCK	2
15	VF47055	WHEEL,6.4"	2
16	VA96851	CAP,AXLE	2
17	VV30111	AXLE	2

Wiring Diagram WT3SPD

