



Electronic Service Manuals

This electronic document is provided as a service to our customers. We do not create the contents of the information contained in this document. Should you have detailed questions pertaining to the information contained in this document, you may contact Michco, or the manufacturer which provided the original information in this electronic deliverable. Michco's only part in this electronic deliverable was the electronic assembly process. By providing this manual on line we are not guaranteeing parts availability.

You may contact Michco through the following methods:

Phone (517) 484-9312 or (800) 331-3339

2011 N. High St. -- Lansing, Michigan -- 48906

Fax: (517) 484-9836

Email: CustServe@Michco.com

Web site: www.Michco.Com

Parts Web site: www.FloorMachineParts.Com

Order Parts on Line at:

www.FloorMachineParts.Com

Directly to Parts & Service:

By Email: **Shop@Michco.com**

By Fax: (517) 702-2041

By Voice: Use numbers above.

Serving the Cleaning Industry Since 1922

Notice: All copyrighted material remains property of original owners, all trademarks are property of respective owners. Manuals are subject to Manufacturer's reproduction limitations. Originals or reproductions were provided by manufacturers through a request. We make no warranty as to the correctness of information provided in this document and you assume all risk. By placing these manuals on line we are not declaring our corporation to be an manufacturer authorized dealer or provider, please check our web site for authorized manufacturers we represent.



V-HDU-14 V-HDU-36

Upright Vacuum Cleaner

Parts Manual

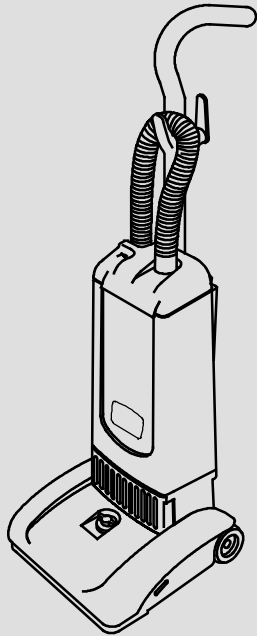
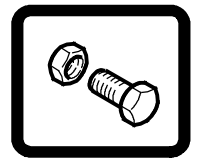

Model Part No.:
9007462 - V-HDU-14 (120V)
9007508 - V-HDU-14 (240V) EMC
9007464 - V-HDU-36 (220V/60Hz)
9007466 - V-HDU-36 (230V/50Hz)



www.tennantco.com

NOBLES

www.nobles.com



To view, print or download
the latest manual, visit:

www.tennantco.com/manuals

9007525
Rev. 03 (06-2014)



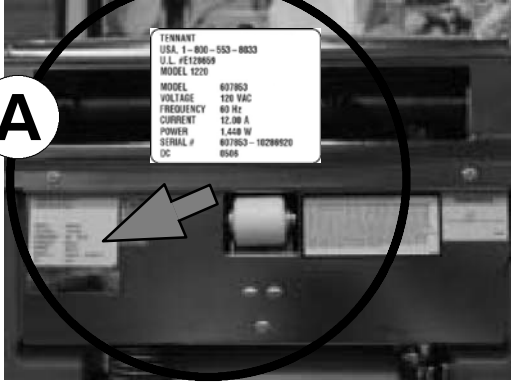

TENNANT
 USA, 1-800-553-8033
 U.L. #E120609
 MODEL 1220
 MODEL 697863
 VOLTAGE 120 VAC
 FREQUENCY 60 Hz
 CURRENT 12.00 A
 POWER 1.448 W
 SERIAL # 697863-10289529
 DC 8566

Ref	Part No.	Serial Number	Description	Qty.
1	82681	(000000-)	Bracket Wldt, Lpg Mount	1
∇ 2	63810	(000000-)	Latch Assy, Lpg Tank Mtg, W/Nut	4
▲ 3	51839	(000000-)	Nut Adjustable, Lpg Tank Mtg	2
4	49263	(000000-)	Tie, Cable	3
	82556	(000000- 001039)	Bracket, Vaporizer	1
	54930	(000000-)	Vaporizer	1

HOW TO ORDER PARTS - See diagram above

Only use TENNANT Company supplied or equivalent parts. Parts and supplies may be ordered online, by phone, by fax or by mail.

Follow the steps below to ensure prompt delivery.

1. (A) Identify the machine model.
2. (A) Identify the machine serial number from the data label.
3. (B) Ensure the proper serial number is used from the parts list.
4. Identify the part number and quantity.
Do not order by page or reference numbers.
5. Provide your name, company name, customer ID number, billing and shipping address, phone number and purchase order number.
6. Provide detail shipping instructions.

- (C) ∇ - identifies an assembly
 ▲ - identifies parts included in assembly

Please fill out at time of installation for future reference.

Model No. - _____
 Serial No. - _____
 Machine Options - _____
 Sales Rep. - _____
 Sales Rep. phone no. - _____
 Customer ID Number - _____
 Installation Date - _____

Tennant Company
 PO Box 1452
 Minneapolis, MN 55440
 Phone: (800) 553-8033 or (763) 513-2850

www.tennantco.com
 www.nobles.com

Specifications and parts are subject to change without notice.

Copyright © 2010 - 2014 TENNANT Company, Printed in U.S.A.

CN	<p>如何订购部件 - 参见下表</p> <p>仅使用 TENNANT 公司提供的或同等部件。部件和供应可以在线订购，通过电话、传真或邮件订购。请遵循下面的步骤确保及时交付。</p> <ol style="list-style-type: none"> 1. (A) 确定机器型号。 2. (B) 从数据标签确定机器序列号。 3. (C) 确保使用部件列表中的正确序列号。 4. 确定部件号和数量。 不要按页面或参考编号订购。 5. 提供您的姓名、公司名称、客户 ID 号、付帐和送货地址、电话号码和采购单编号。 6. 提供详细的送货说明。 <hr/> <p>(D) ▽ - 确定组件 ▲ - 确定组件中包含的组件</p>	<p>请在安装时填写供未来参考。</p> <p>型号 - _____</p> <p>序列号 - _____</p> <p>机器选项 - _____</p> <p>销售代表 - _____</p> <p>销售代表电话号码 - _____</p> <p>客户 ID 编号 - _____</p> <p>安装日期 - _____</p>
-----------	--	--

ES	<p>CÓMO SOLICITAR PIEZAS - Consulte el diagrama anterior.</p> <p>Utilice sólo las piezas suministradas por TENNANT Company o piezas equivalentes. Puede solicitar las piezas a través de internet, por teléfono, por fax o por correo.</p> <p>Siga los siguientes pasos para que la entrega sea rápida.</p> <ol style="list-style-type: none"> 1. (A) Indique el modelo de máquina. 2. (B) Indique el número de serie de la etiqueta de datos. 3. (C) Asegúrese de que indica el número de serie correcto de la lista de piezas. 4. Indique la cantidad y el número de la pieza. No realice el pedido indicando el número de página o el de referencia. 5. Incluya su nombre, el nombre de la empresa, el ID de cliente, las direcciones de envío y facturación, el número de teléfono y el número del pedido de compra. 6. Facilite instrucciones de envío. <hr/> <p>(D) ▽ - identifica un conjunto ▲ - identifica piezas de un conjunto</p>	<p>Rellene estos datos cuando realice la instalación para utilizarlos como referencia en el futuro.</p> <p>Nº modelo - _____</p> <p>Nº serie - _____</p> <p>Opciones de la máquina - _____</p> <p>Vendedor - _____</p> <p>Nº teléfono vendedor - _____</p> <p>Nº cliente - _____</p> <p>Fecha de instalación - _____</p>
-----------	--	---

FR	<p>COMMENT COMMANDER DES PIÈCES DÉTACHÉES - Voir le schéma ci-dessus.</p> <p>Utilisez uniquement des pièces fournies par la société TENNANT ou équivalentes. Les pièces et fournitures peuvent être commandées en ligne, par téléphone, fax, ou par courrier.</p> <p>Suivez les étapes ci-dessous pour assurer une livraison rapide.</p> <ol style="list-style-type: none"> 1. (A) Identifiez le modèle de la machine. 2. (B) Identifiez le numéro de série de la machine, à partir de l'étiquette signalétique. 3. (C) Assurez-vous que le numéro de série correct est utilisé à partir de la liste de pièces détachées. 4. Identifiez le numéro de pièce et la quantité. Ne commandez pas par page ou numéros de référence. 5. Fournissez votre nom, le nom de votre société, votre numéro d'identification de client, l'adresse de facturation et d'expédition, le numéro de téléphone et le numéro du bon de commande. 6. Fournissez des instructions d'expédition détaillées. <hr/> <p>(D) ▽ - identifie un assemblage ▲ - identifie les pièces composant l'assemblage</p>	<p>A remplir au moment de l'installation à titre de référence.</p> <p>Nº du modèle - _____</p> <p>Nº de série - _____</p> <p>Options de la machine - _____</p> <p>Agent commercial - _____</p> <p>Nº tél. de l'agent commercial - _____</p> <p>Numéro d'identification client - _____</p> <p>Date d'installation - _____</p>
-----------	--	---

JP	<p>パーツの発注方法 ? 上記の図を参照してください</p> <p>TENNANT社製のパーツまたは同等品のみをお使いください。パーツやサプライ品のご注文は、オンライン、電話、FAX、または手紙でお願いいたします。確実にお届けできるように、以下の情報お知らせください。</p> <ol style="list-style-type: none"> 1. (A) 製品のモデル名をお知らせください。 2. (B) 製品のデータラベルに印刷されているシリアル番号をお知らせください。 3. (G) パーツリストを参照して、シリアル番号が正しいかご確認ください。 4. パーツ番号と数量をお知らせください。マニュアル/カタログのページ番号や参照番号でのご注文はご遠慮ください。 5. お客様のお名前、会社名、顧客ID番号、請求/発送先住所、電話番号、注文書番号をお知らせください。 6. 発送に関するご希望があれば、明記してください。 <hr/> <p>(D) ▽ - アセンブリを示します ▲ - アセンブリに含まれるパーツを示します</p>	<p>後日確認できるように、設置時に記入してください。</p> <p>モデルNo. - _____</p> <p>シリアルNo. - _____</p> <p>製品のオプション - _____</p> <p>販売代理店 - _____</p> <p>販売代理店の電話番号 - _____</p> <p>顧客ID番号 - _____</p> <p>設置日 - _____</p>
-----------	---	---

GENERAL RECOMMENDED MAINTENANCE
ITEMS 6

STANDARD PARTS

BAG HOUSING GROUP 8
BAG HOUSING GROUP - CONT'D 10
VACUUM MOTOR HOUSING GROUP 12
BRUSH BASE GROUP 14
WIRING DIAGRAM, 120V 16
WIRING DIAGRAM, 220V/230V/240V 17

RECOMMENDED MAINTENANCE ITEMS

GENERAL RECOMMENDED MAINTENANCE ITEMS

Part No.	Serial Number	Description	Qty.
1061695	(00000000-) Hose, Vacuum, 1.25id, Wand	1
604833	(00000000-) Gasket, .19, 04.75w 06.62l, Adh	1
1067457	(00000000-) Bag, Vacuum, Paper [1pick=1ctn] (Standard) (1 Ctn = 100 Bags)	1
1067455	(00000000-) Bag, Vacuum, Paper (Standard) (1 Pkg = 10 Bags)	1
900034	(00000000-) Bag, Cloth, Vacuum, Generic [Lt/Viper] (Optional) (1 Pkg = 1 Bag)	1
604839	(00000000-) Switch, Snap	1
605994	(00000000-) Circuitboard, 120vac [3220] (120V)	1
605995	(00000000-) Circuitboard, 240vac [3220] (220V/230V/240V)	1
604832	(00000000-) Filter, Motor, Secondary [1pick=1fltr]	1
1071239	(00000000-) Cord, Power, 16/3, 40ft Ylw,W/Grip[Sjt] (120V)	1
600398	(00000000-) Cord, Power, 1.0mm2/3 Blk [12meter Euro] (220V/230V)	1
1038777	(00000000-) Cord, Power, 1.0mm /3 Blk [15meter Aus] (240V EMC)	1
130166	(00000000-) Grip, Cord, Strainrelief Pg- 11 W/Nut Bk	1
604847	(00000000-) Clip, Grip, Hose, 1.50d, Gray Pyp	1
611311	(00000000-) Spring, Cmpr, 0.40od .05wir 00.5l, Pl,Mw	1
578005000	(00000000-) Switch, Rocker, Spst (120V)	1
602669	(00000000-) Switch, Rocker, Dpst (220V/230V/240V)	1
1061370	(00000000-) Tool, 35mm 1.38inch [Crevice]	1
140324	(00000000-) Clamp, Cable, Nyl, 0.31d, Blk	1
610906	(00000000-) Hook, Cord [Viper]	1
▽	604815	(00000000-) Fan, Vacuum, 5.1d, 120vac, 1 Stage [Tf] (120V)	1
▲	606382	(00000000-) Brush, Carbon [120v 2pk]	2
▽	605996	(00000000-) Fan, Vacuum, 5.1d, 230vac, 1 Stage [Tf] (220V/230V/240V)	1
▲	606417	(00000000-) Brush, Carbon [Viper 230v 2pk]	2
	1067683	(00000000-) Filter, Dust, Exhaust [1pick=1pkg] (1 Pkg = 4 Filters)	1
	604811	(00000000-) Knob [Height Adjmt]	1
	130398	(00000000-) Motor, Ele, 120vac 1.00hp 60hz [Br Drv] (120V)	1
	130399	(00000000-) Motor, Ele, 240vac, Brush Drive [A/L] (220V/230V/240V)	1
	578005000	(00000000-) Switch, Rocker, Spst	1
▽	1061694	(00000000-) Hose Assy, Vacuum, 1.25d	1
▲	1061692	(00000000-) Cuff, Base, Inlet	1
▲	1061643	(00000000-) Hose, Vacuum, 1.25id X 006.5l, Blk[4:1]	1
▲	1061693	(00000000-) Cuff, Wand	1
	1014918	(00000000-) Wheel, 03.0d 0.88w 0.31b, W/ Bshg, Rbr	2
	230754	(00000000-) Cam, Adjmt, Rlr	1
▽	604803	(00000000-) Brush, Scb, 14l, 01sr, Nyl	1
▲	140125	(00000000-) Bearing, Brush, 0.32b 0.87d 0.28w	2
▲	230429	(00000000-) Block, Brg	2
	230348	(00000000-) Pulley, Brush [Dbl V]	1
	230349	(00000000-) Belt, Drive, Brush, Rnd	2
	701086	(00000000-) Base Assy, Rlr, W/ Bracket	1
	230347	(00000000-) Pulley, Motor [Dbl V]	1

BAG HOUSING GROUP

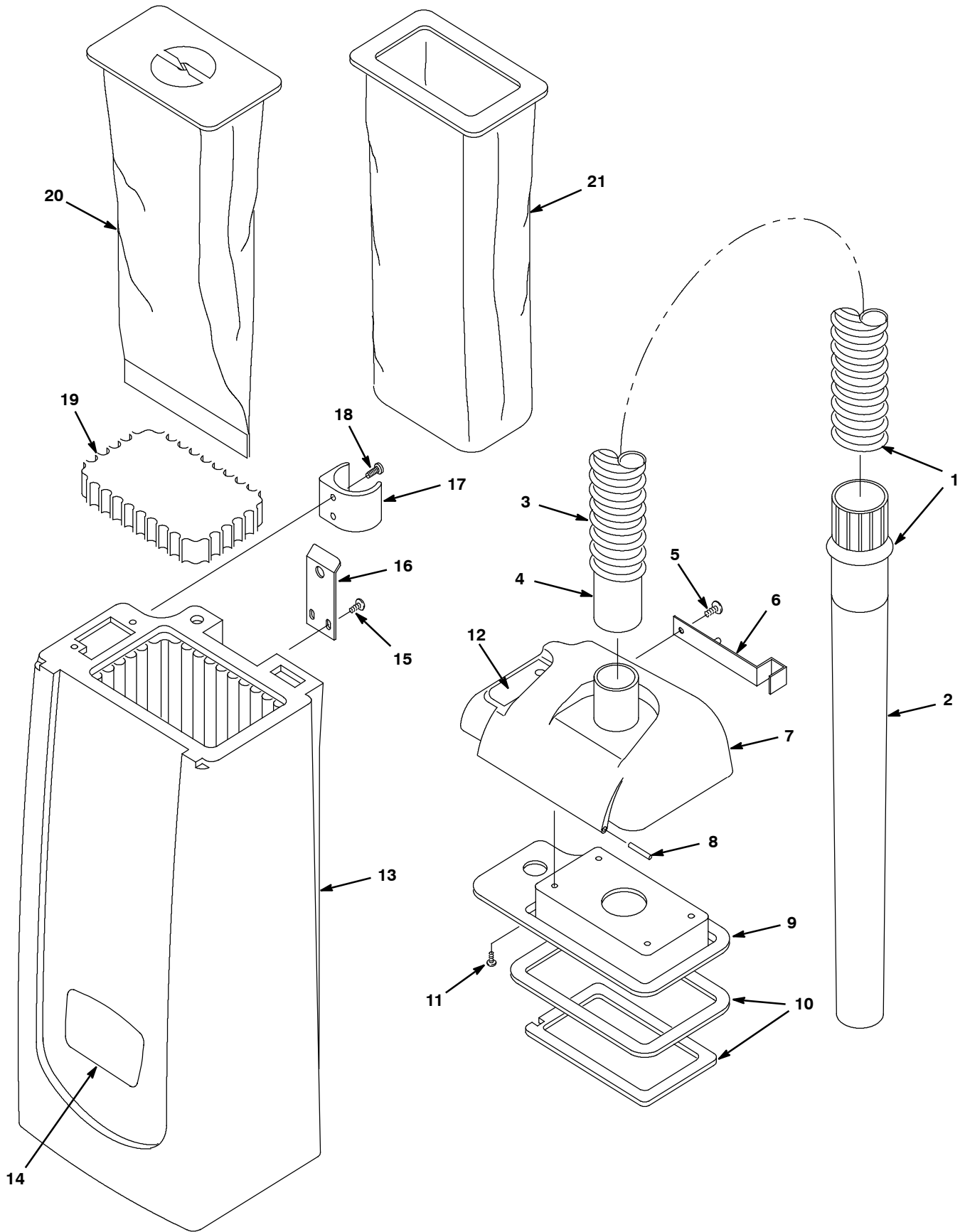

BAG HOUSING GROUP

Ref.	Part No.	Serial Number	Description	Qty.
▽	1	1061695	(00000000-) Hose, Vacuum, 1.25id, Wand	1
▲	2	1061697	(00000000-) Wand, Swivel, 35mm Id X 19l	1
▲	3	1061696	(00000000-) Hose, Vacuum, 1.25id 1.56od 018.0l [4:1]	1
▲	4	160471	(00000000-) Cuff, Hose, 1.5id Hose, 3.5l, Blk, Taper [Lt]	1
	5	604930	(00000000-) Screw, Trs, M5 X 0.80 X 10, Phl, Pl, NI	1
	6	605016	(00000000-) Latch, Lid [Viper]	1
	7	1042508	(00000000-) Cover, Hsng, Bag, [Hawk Gray]	1
	8	603114	(00000000-) Pin, Dowel, 0.125d X 1.25l	2
	9	604836	(00000000-) Lid, Plt, Bottom	1
	10	604833	(00000000-) Gasket, .19, 04.75w 06.62l, Adh	1
	11	140825	(00000000-) Screw, Pan, Phl, 06 X 0.50, Fmg/Ab, Blk	4
	12	605998	(00000000-) Label, Indicator Light [Viper]	1
	13	9007686	(00000000-) Housing, Bag, Rm- Cphg, Afmkt (120V)	1
	13	9007850	(00000000-) Housing, Bag, Rm- Cphg, Afmkt (220V/230V/240V)	1
	14	1060465	(00000000-) Label, Logo, Cmdty, Dual, Small	1
	14	1060463	(00000000-) Label, Logo, Cmdty, Tco, Small	1
	15	606694	(00000000-) Screw, Trs, M4 X 0.70 X 8, Phl, Pl	2
	16	604844	(00000000-) Strike Lid Latch	1
	17	604847	(00000000-) Clip, Grip, Hose, 1.50d, Gray Pyp	1
	18	607006	(00000000-) Screw, Trs, M4 X 0.70 X 12, Phl, Pl	2
	19	604832	(00000000-) Filter, Motor, Secondary [1pick=1fltr]	1
	20	1067457	(00000000-) Bag, Vacuum, Paper (Standard) (1 Ctn = 100 Bags)	1
	20	1067455	(00000000-) Bag, Vacuum, Paper (Standard) (1 Pkg = 10 Bags)	1
	21	900034	(00000000-) Bag, Cloth, Vacuum, Generic (Optional) (1 Pkg = 1 Bag)	1

▽ ASSEMBLY

▲ INCLUDED IN ASSEMBLY

BAG HOUSING GROUP - CONT'D

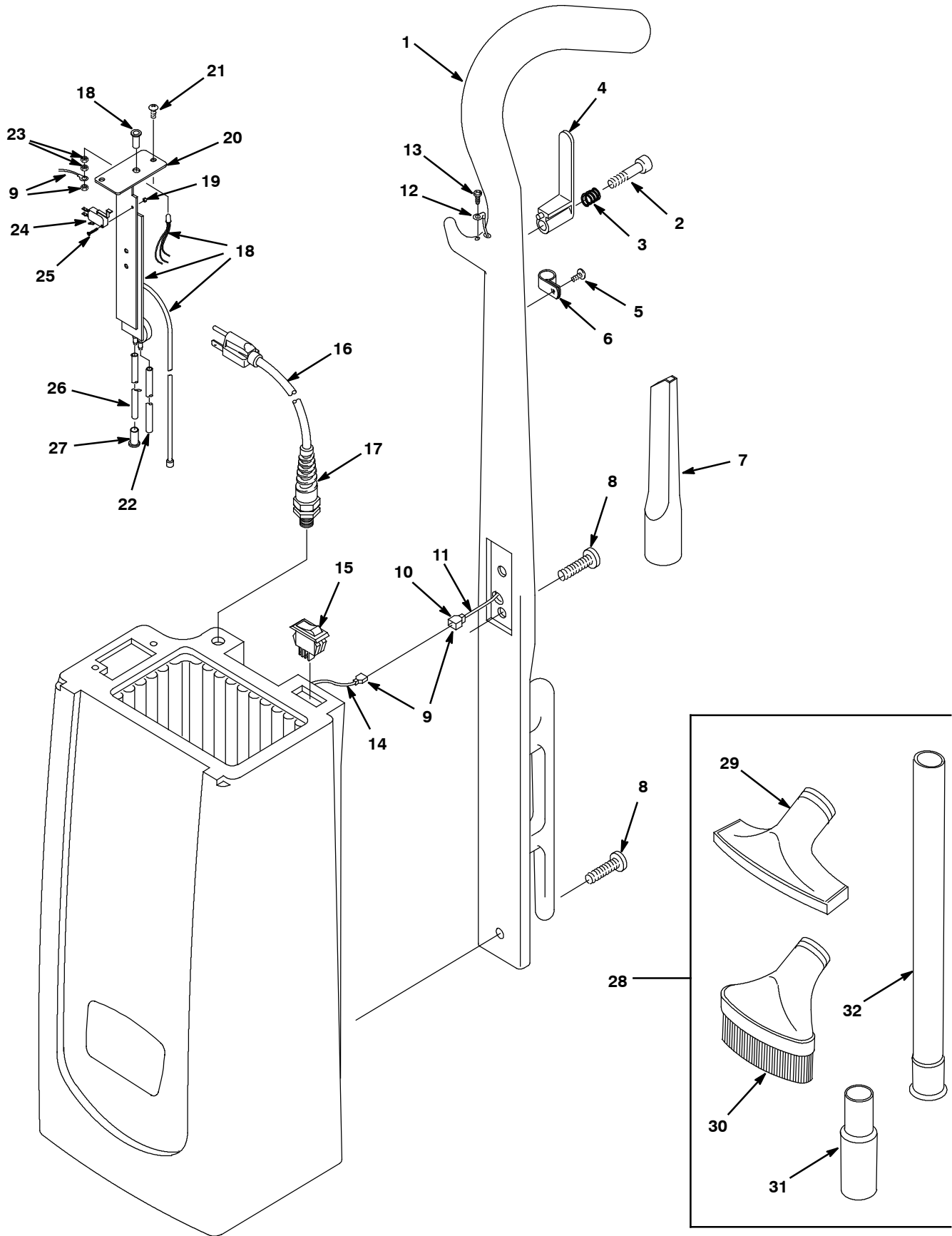

BAG HOUSING GROUP - CONT'D

Ref.	Part No.	Serial Number	Description	Qty.	
1	9007684	(00000000-) Handle, Vac, Rm- Blk, Afmkt [V- Hdu- 14]	1	
2	1024965	(00000000-) Bolt, Shld, 08mmd X 030mm, M06 X 1.0	1	
3	611311	(00000000-) Spring, Cmpr, 0.40od .05wir 00.5l, Pl,Mw	1	
4	610906	(00000000-) Hook, Cord [Viper]	1	
5	607006	(00000000-) Screw, Trs, M4 X 0.70 X 12, Phl, Pl	1	
6	140324	(00000000-) Clamp, Cable, Nyl, 0.31d, Blk	1	
7	1061370	(00000000-) Tool, 35mm 1.38inch [Crevice] (Standard)	1	
8	607137	(00000000-) Screw, Trs, M6 X 1.00 X 35, Phl, Pl	2	
▽	9	607286	(00000000-) Wire Kit, Static [Viper]	1
▲	10	130133	(00000000-) Terminal, Mal, .25 22- 18ga Red, F- Ins	1
▲	11	607285	(00000000-) Wire, 18ga 18.5l Green .14ring /Stripped	1
▲	12	130130	(00000000-) Terminal, Ring #10stud 22- 18ga	1
▲	13	140825	(00000000-) Screw, Pan, Phl, 06 X 0.50, Fmg/Ab, Blk	1
▲	14	607284	(00000000-) Wire, 18ga 18.5l Green .25qf / Stripped	1
▲		140297	(00000000-) Nut, Hex, Std, M5 X 0.80, Ss	1
15	578005000	(00000000-) Switch, Rocker, Spst (120V)	1	
15	602669	(00000000-) Switch, Rocker, Dpst (220V/230V/240V)	1	
16	1071239	(00000000-) Cord, Power, 16/3, 40ft Ylw,W/Grip[Sjt] (120V)	1	
16	600398	(00000000-) Cord, Power, 1.0mm2/3 Blk [12meter Euro] (220V/230V)	1	
16	1038777	(00000000-) Cord, Power, 1.0mm /3 Blk [15meter Aus] (240V EMC)	1	
17	130166	(00000000-) Grip, Cord, Strainrelief Pg- 11 W/Nut Bk	1	
18	605994	(00000000-) Circuitboard, 120vac [3220] (120V)	1	
18	605995	(00000000-) Circuitboard, 240vac [3220] (220V/230V/240V)	1	
19	579211	(00000000-) Nut, Hex, Lock, M3 X 0.50, NI, Ss	2	
20	604835	(00000000-) Bracket Wldt, Switch / Light	1	
21	606694	(00000000-) Screw, Trs, M4 X 0.70 X 8, Phl, Pl	2	
22	608917	(00000000-) Hose, Vyl, 0.13id 0.25od 018.0l, Red	1	
23	140297	(00000000-) Nut, Hex, Std, M5 X 0.80, Ss	2	
24	1073723	(00000000-) Switch, Snap, 20a	1	
25	200070266	(00000000-) Screw, Pan, Phl, M3 X 0.50 X 16, Pl	2	
26	606357	(00000000-) Hose, Pvc, Clr, 0.12id 0.25od 018.0l	1	
27	605984	(00000000-) Bushing [Bag- Full- Hose]	1	
▽	28	604802	(00000000-) Attmnt Kit [Viper/3220] (Optional Kit)	1
▲	29	609194	(00000000-) Tool, Blk [Upholstery] (Optional)	1
▲	30	609193	(00000000-) Tool, Attmnt, Brush, Blk [Dusting] (Optional)	1
▲	31	609196	(00000000-) Adapter, Tool, Blk (Optional)	1
▲	32	609195	(00000000-) Wand, Extn, Blk (Optional)	1

▽ ASSEMBLY

▲ INCLUDED IN ASSEMBLY

VACUUM MOTOR HOUSING GROUP

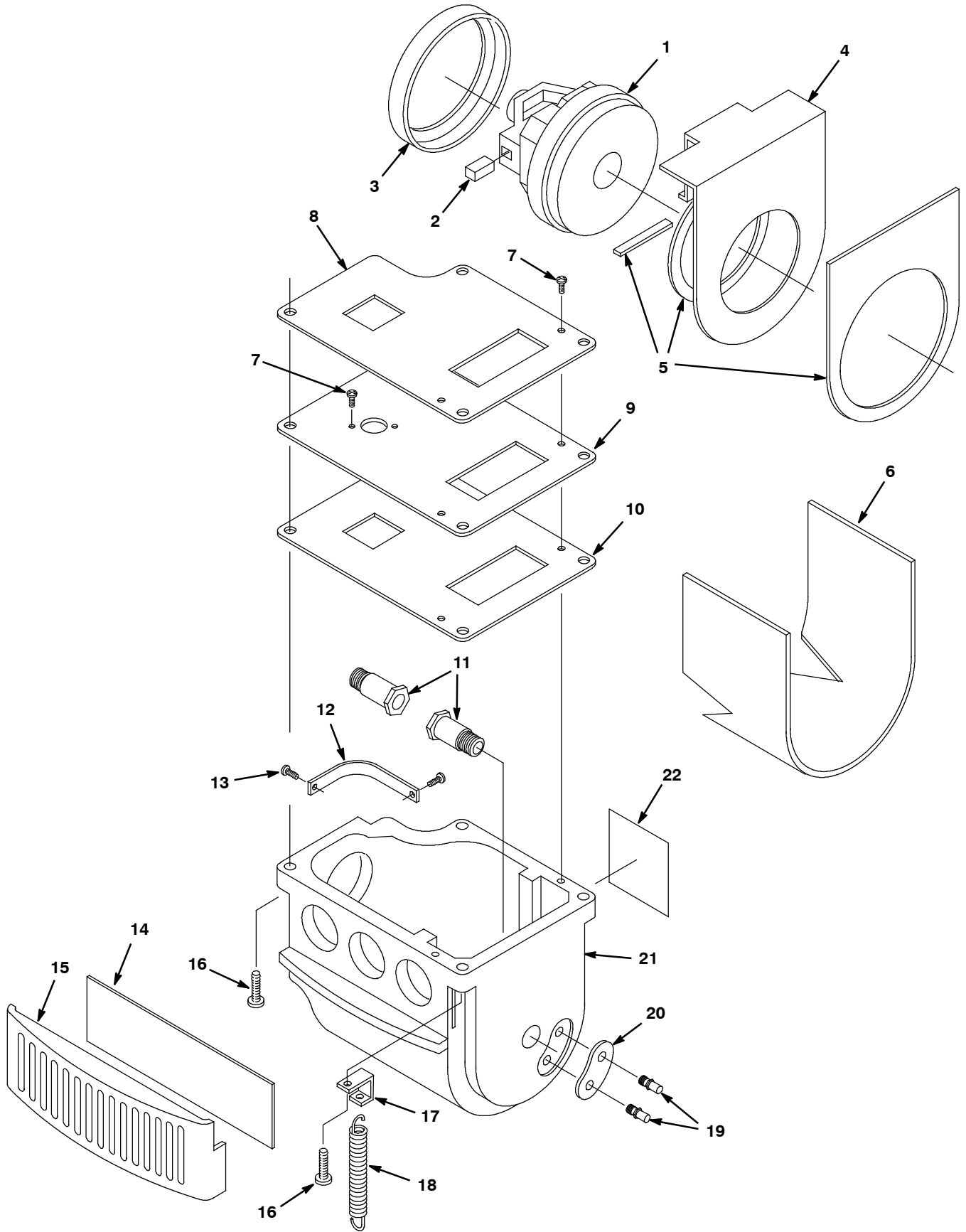

VACUUM MOTOR HOUSING GROUP

	Ref.	Part No.	Serial Number	Description	Qty.
▽	1	604815	(00000000-) Fan, Vacuum, 5.1d, 120vac, 1 Stage (120V)	1
▲	2	606382	(00000000-) Brush, Carbon [120v 2pk]	2
▽	1	605996	(00000000-) Fan, Vacuum, 5.1d, 230vac, 1 Stage (220V/230V/240V)	1
▲	2	606417	(00000000-) Brush, Carbon [Viper 230v 2pk]	2
	3	604816	(00000000-) Gasket, Motor, Vacuum	1
	4	604826	(00000000-) Plate, Inlet, Vacuum Motor	1
	5	605080	(00000000-) Gasket, Pl, Inlet, .06th	1
	6	604822	(00000000-) Insulation, Acstc, 0.5, 14.0 X 05.3	1
	7	579259	(00000000-) Screw, Pan, Phl, M4 X 0.70 X 12, Pl	4
	8	606732	(00000000-) Gasket, Plt, Upper Clamp, .12th, Adh	1
	9	606730	(00000000-) Plate, Clamp, Vacuum Motor	1
	10	606731	(00000000-) Gasket, Plt, Lower Clamp	1
	11	611734	(00000000-) Bolt, Shld, 19mmd X 024mm, M16 X 2.0,Nyl	2
	12	604830	(00000000-) Strap, Cuff, Wand	1
	13	607006	(00000000-) Screw, Trs, M4 X 0.70 X 12, Phl, Pl	2
	14	1067683	(00000000-) Filter, Dust, Exhaust [1pick=1pkg] (1 Pkg = 4 Filters)	1
	15	1029486	(00000000-) Cover, Fltr, Exhaust Hawk Gray	1
	16	607137	(00000000-) Screw, Trs, M6 X 1.00 X 35, Phl, Pl	4
	17	608196	(00000000-) Mount, Spring, Vacuum Hsng	1
	18	608071	(00000000-) Spring, Extn, 0.50od 0.07wir 05.0l	1
	19	604827	(00000000-) Stud, Latch, Foot	2
	20	606723	(00000000-) Plate, Latch, Foot	1
	21	9007675	(00000000-) Housing, Motor, Rm- Cphg, Afmkt [V- Hdu- 1	1
	22	1026381	(00000000-) Label, Warning [Ac Vacuums En/Fr/Es]	1
	N/S	605981	(00000000-) Harness, Lower [Viper]	1

▽ ASSEMBLY

▲ INCLUDED IN ASSEMBLY

BRUSH BASE GROUP

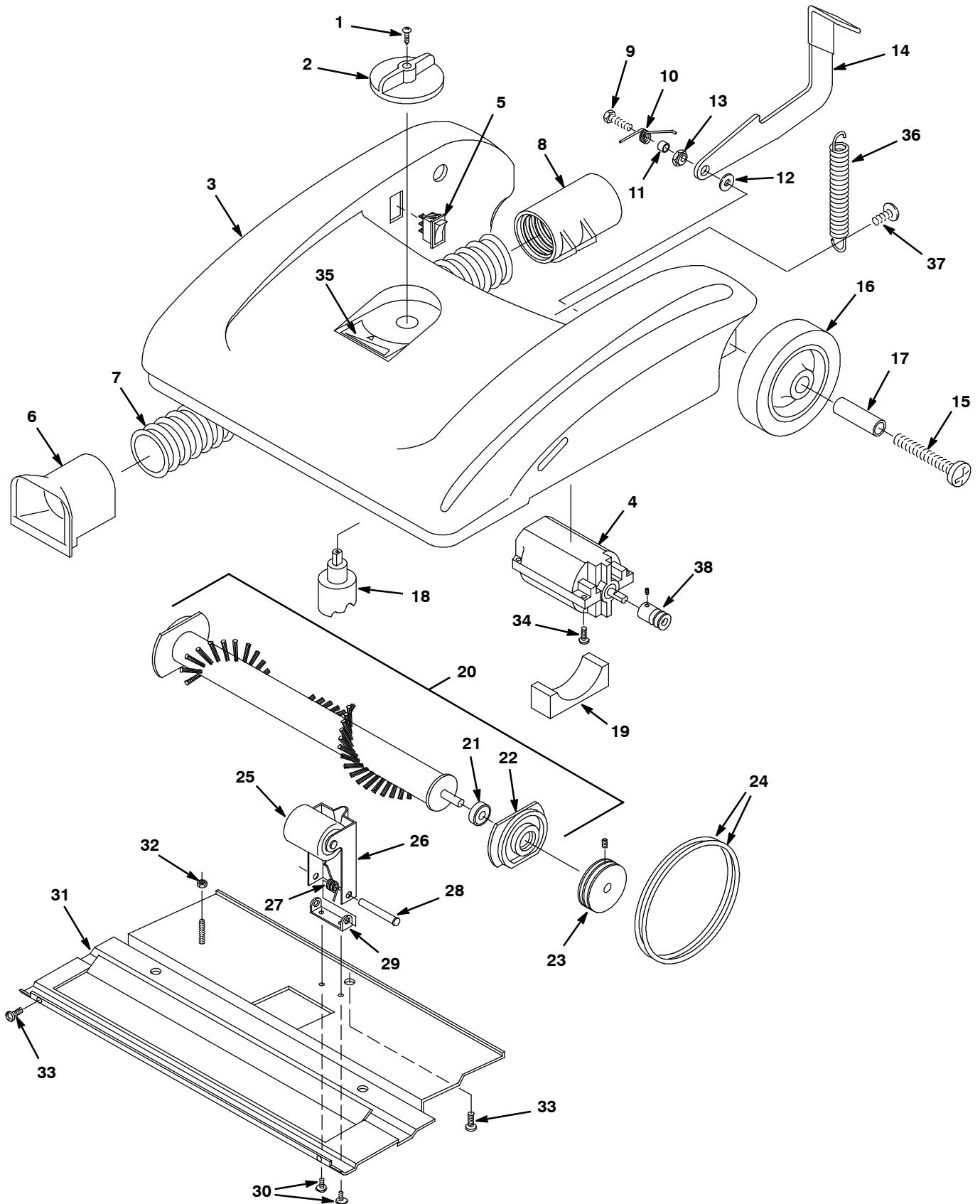

BRUSH BASE GROUP

Ref.	Part No.	Serial Number	Description	Qty.	
1	140825	(00000000-) Screw, Pan, Phl, 06 X 0.50, Fmg/Ab, Blk	1	
2	604811	(00000000-) Knob [Height Adjmt]	1	
3	9007677	(00000000-) Base, Vac, Afmkt [V- Hdu- 14]	1	
4	130398	(00000000-) Motor, Ele, 120vac 1.00hp 60hz (120V)	1	
4	130399	(00000000-) Motor, Ele, 240vac, Brush Drive (220V/230V/240V)	1	
5	578005000	(00000000-) Switch, Rocker, Spst	1	
▽	1061694	(00000000-) Hose Assy, Vacuum, 1.25d	1	
▲	6	1061692	(00000000-) Cuff, Base, Inlet	1
▲	7	1061643	(00000000-) Hose, Vacuum, 1.25id X 006.5l, Blk[4:1]	1
▲	8	1061693	(00000000-) Cuff, Wand	1
9	610905	(00000000-) Screw, Hex, M6 X 1.00 X 25, NI, PI	1	
10	610861	(00000000-) Spring, Tors	1	
11	140154	(00000000-) Sleeve, P/M, 0.25b 0.38d 0.3l, PI	1	
12	579210	(00000000-) Washer, Flat, M6.4b X 18d X 1.5, PI	1	
13	605078	(00000000-) Bushing, Hex, Off Cntr[Footlatch, Viper]	1	
14	604808	(00000000-) Latch, Base, Foot	1	
15	605079	(00000000-) Screw, Trs, M8 X 1.25 X 35, Phl, PI, NI	2	
▽	16	1014918	(00000000-) Wheel, 03.0d 0.88w 0.31b, W/ Bshg, Rbr	2
▲	17	103070	(00000000-) Bushing, Wheel, F/630450	2
18	230754	(00000000-) Cam, Adjmt, Rlr	1	
19	604812	(00000000-) Gasket, Motor, Brush, Ure Foam	1	
▽	20	604803	(00000000-) Brush, Scb, 14l, 01sr, Nyl	1
▲	21	140125	(00000000-) Bearing, Brush, 0.32b 0.87d 0.28w	2
▲	22	230429	(00000000-) Block, Brg	2
23	230348	(00000000-) Pulley, Brush [Dbl V]	1	
24	230349	(00000000-) Belt, Drive, Brush, Rnd	2	
▽	701086	(00000000-) Base Assy, Rlr, W/ Bracket	1	
▲	25	605317	(00000000-) Roller, Sqge, 1.35od X 1.48l [Delrin]	1
▲	26	230753	(00000000-) Bracket, Rlr	1
▲	27	140436	(00000000-) Spring, Tors [Ht Adjmnt]	1
▲	28	140710	(00000000-) Rivet, Axle, .38d X 1.6	2
▲	29	230769	(00000000-) Bracket, Rlr, Pivot	1
30	140264	(00000000-) Screw, Trs, Phl, 08- 32 X 0.25, PI	2	
31	606733	(00000000-) Plate, Floor, 14.00 [Viper, Shoe]	1	
32	140297	(00000000-) Nut, Hex, Std, M5 X 0.80, Ss	1	
33	606694	(00000000-) Screw, Trs, M4 X 0.70 X 8, Phl, PI	5	
34	140826	(00000000-) Screw, Pan, Phl, 06- 20 X 0.75, Fmg/Ab,Ss	2	
35	606691	(00000000-) Label [Height- Adjustment, 3220 Viper]	1	
36	608071	(00000000-) Spring, Extn, 0.50od 0.07wir 05.0l	1	
37	606507	(00000000-) Screw, Pan, M8 X 1.25 X 25, Phl, PI	1	
38	230347	(00000000-) Pulley, Motor [Dbl V]	1	

▽ ASSEMBLY

▲ INCLUDED IN ASSEMBLY

WIRING DIAGRAM, 120V

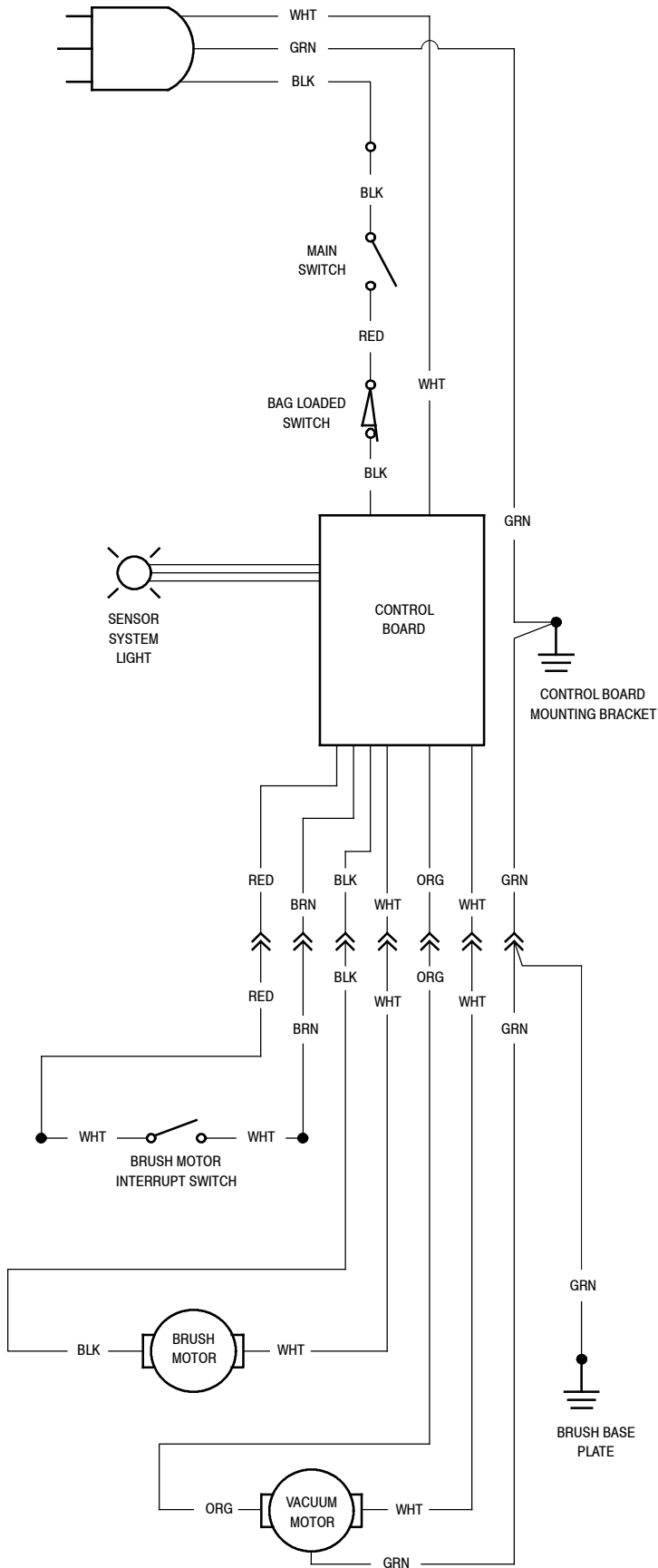

WIRING DIAGRAM, 220V/230V/240V

