



Electronic Service Manuals

This electronic document is provided as a service to our customers. We do not create the contents of the information contained in this document. Should you have detailed questions pertaining to the information contained in this document, you may contact Michco, or the manufacturer which provided the original information in this electronic deliverable. Michco's only part in this electronic deliverable was the electronic assembly process. By providing this manual on line we are not guaranteeing parts availability.

You may contact Michco through the following methods:

Phone (517) 484-9312 or (800) 331-3339

2011 N. High St. -- Lansing, Michigan -- 48906

Fax: (517) 484-9836

Email: CustServe@Michco.com

Web site: www.Michco.Com

Parts Web site: www.FloorMachineParts.Com

Order Parts on Line at:

www.FloorMachineParts.Com

Directly to Parts & Service:

By Email: **Shop@Michco.com**

By Fax: (517) 702-2041

By Voice: Use numbers above.

Serving the Cleaning Industry Since 1922

Notice: All copyrighted material remains property of original owners, all trademarks are property of respective owners. Manuals are subject to Manufacturer's reproduction limitations. Originals or reproductions were provided by manufacturers through a request. We make no warranty as to the correctness of information provided in this document and you assume all risk. By placing these manuals on line we are not declaring our corporation to be an manufacturer authorized dealer or provider, please check our web site for authorized manufacturers we represent.



186E

(Parts Manual)

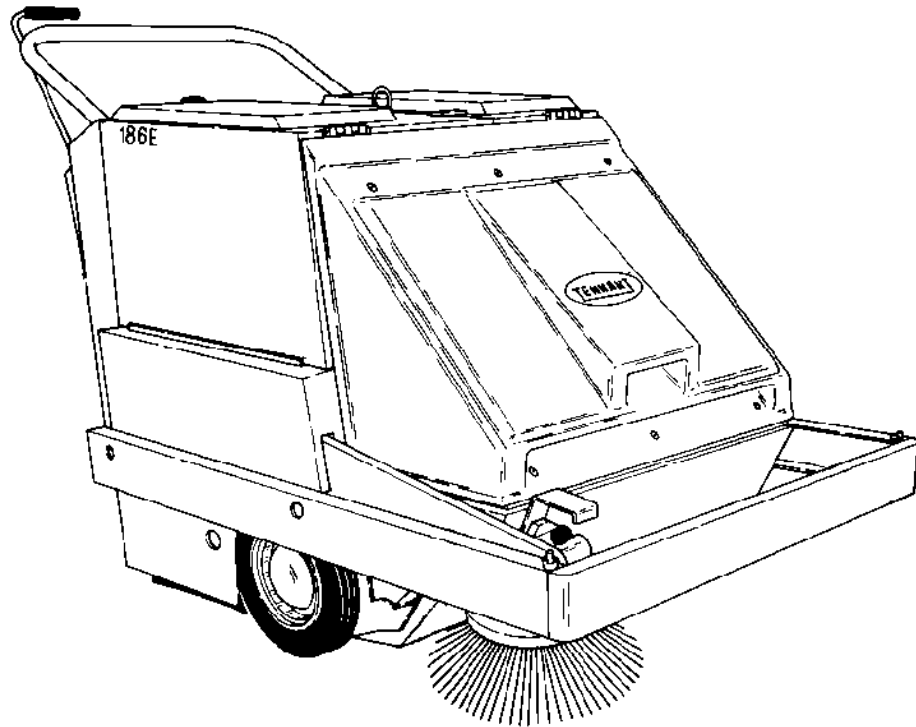

MM160
Rev. 12 (12-95)



This manual is furnished with each new TENNANT Model 186E. It provides necessary operating and preventive maintenance instructions. Read this manual completely and understand the machine before operating or servicing it.

This manual covers all machine variations and standard options. The instruction portion of the manual consists of the Specification, Operation, Maintenance, and Appendix sections. The parts portion consists of the Standard Parts; EE Parts; Options; Electrical Components; and Cross Reference sections.

All right side and left side references to the machine are determined by facing the direction of forward travel. All hardware considered to be of a common nature or locally available has been omitted from the parts sections. Be aware that this machine may contain metric hardware. Make sure you use equivalent hardware when replacement becomes necessary.

This machine will provide excellent service. However, the best results will be obtained at minimum costs if:

- The machine is operated with reasonable care.
- The machine is maintained regularly – per the maintenance instructions provided.
- The machine is maintained with Tennant Company supplied or equivalent parts.

Parts and supplies may be ordered by phone or mail from any Tennant Company parts and service center, distributor, or from any of the Tennant Company subsidiaries. Before ordering parts or supplies, be sure to have your machine model number and serial number handy. Fill out the data block below for future reference.

MACHINE DATA <i>Please fill out at time of installation.</i>
Machine Serial Number – _____
Engine Serial Number – _____
Sales Representative – _____
Customer Number – _____
Date of Installation – _____
Manual Number – MM160
Revision: 12
Published: 12-95

Trademark Registered in: Austria, Benelux, Denmark, England, France, Germany, Italy, Spain, Switzerland, United States, Argentina, Australia, Canada, Japan, Mexico, Sweden, by TENNANT COMPANY, Minneapolis, Minnesota, U.S.A.

Copyright 1986, 1987, 1988, 1989, 1990, 1991, 1992, 1994, 1995 Tennant Company, Printed in U.S.A.

HOW TO USE THIS MANUAL

This section on *HOW TO USE THIS MANUAL* will tell you how to:

- Find important machine information for ordering correct repair parts.
- Find TENNANT part numbers.
- Order TENNANT parts and supplies.

IMPORTANT INFORMATION

When placing an order for parts, the machine model and machine serial number are important. Refer to the *MACHINE DATA* box which is filled out during the installation of your machine. The *MACHINE DATA* box is located on the inside of the front cover of this manual.

MACHINE DATA	
<i>Please fill out at time of installation.</i>	
Machine Serial Number -	_____
Engine Serial Number -	_____
Sales Representative -	_____
Customer Number -	_____
Date of Installation -	_____
Manual Number -	MM160
Revision:	10
Published:	6-94

The model number of your machine is on the side of the machine.

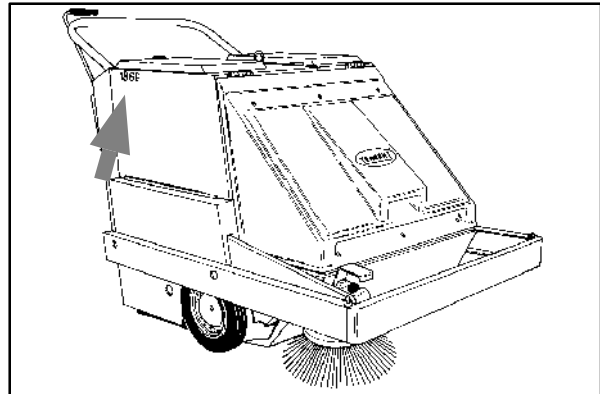

The serial number of your machine is printed on the machine data plate located as shown.

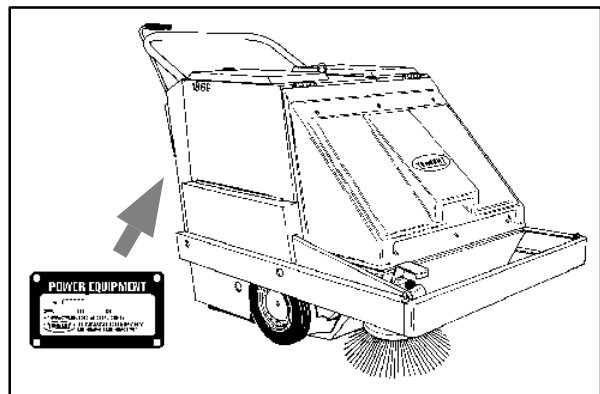

HOW TO USE THIS MANUAL

FINDING A TENNANT PART NUMBER

This manual contains the following sections:

- HOW TO USE THIS MANUAL
- STANDARD PARTS
- OPTIONS
- BREAKDOWNS
- CROSS REFERENCE

The STANDARD PARTS section lists repair parts for standard machines. They are grouped in this general order:

- General wear parts.
- Machine frame and related parts.
- Machine propelling system.
- Scrubbing components.
- Electrical parts.

The OPTION section lists repair parts of options.

The BREAKDOWN section lists available repair parts of major components.

All sections in this manual consist of parts illustrations and corresponding parts lists.

The parts illustrations are numbered with **Ref** numbers which refer to corresponding parts lists.

The parts lists include a number of columns of information:

- **Ref** – column refers to the reference number on the parts illustration.
- ∇ – indicates the part is an assembly.
- ▲ – indicates the part is included in the assembly listed just before it.
- **TENNANT Part No.** – column lists the TENNANT part number for the part.
- **Serial Number** – column indicates the set of machines the part number is applicable to. Serial numbers change when the machine design has been modified. The most current design of the machine is shown in the main illustration, older designs are boxed in a corner of the illustration.
- **Description** – column is a brief description of the part.
- **Qty.** – column lists the quantity of that part used in that area of the machine.

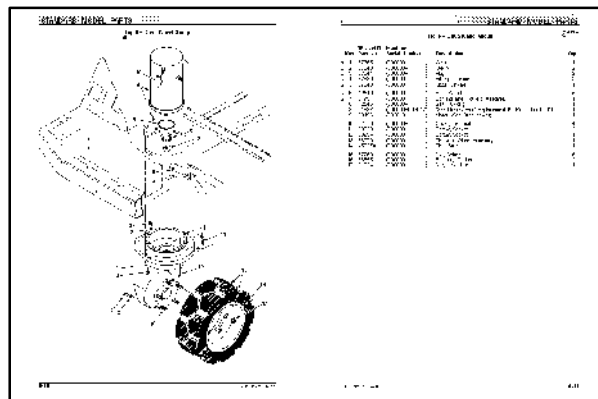

Key	TENNANT Part No.	Machine Serial Number	Description	Qty.
∇ 1	87366	(00000)-	Gearbox	1
▲ 2	87840	(00000)-	O-Ring	2
▲ 3	87841	(UUUUU)-	Hub	2
▲ 4	87839	(00000)-	Fitting, Grease	2
▲ 5	87849	(00000)-	Gear, Driving	1
▲ 6	12540	(00000)-	Bolt, Wheel	5
▲ 7	01791	(00000)-	Bearing and Housing Assembly	1
▲ 8	12545	(00000)-	Seal, O-Ring	1
9	31592	(00000-032017)	(See Breakdowns) Replacement Kit Motor For 86356	1
9	80196	(00015)-	Motor (See Breakdowns)	1
10	02076	(00000)-	Cover, Terminal	4
11	09000	(00000)-	Cover, Socket	2
12	09294	(00000)-	Screw, Socket	1
13	86970	(00000)-	Tire and Wheel Assembly	1
14	45027A	(00000)-	Tire, Solid	1
15	87760	(00000)-	Nut, Wheel	5
16	56855	(00000)-	Bumper, Rubber	2
17	51824	(00000)-	Nut, Hex, "Tri"	1

NOTE: If a service kit is installed on your machine, be sure to keep the **INSTRUCTION BULLETIN** which came with the kit. It contains repair parts numbers needed for ordering future parts.

NOTE: Fasteners used in this machine may be metric or non-metric. Take care when replacing hardware to replace with same thread size.

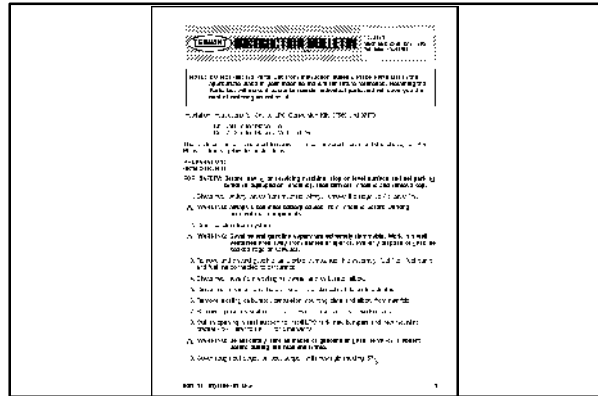

PLACING AN ORDER

Orders may be placed by phone, fax, or by mail. Phone orders may need written confirmation. Follow the steps below to insure prompt delivery:

1. Identify the model number of your machine.
2. Identify the serial number of your machine.
3. Find the part number of the part you need. Do not order by page number or reference number. If you are not able to find the part number, call your TENNANT representative for help or send the old part as a sample.
4. Determine the quantity of the part you need.
5. Provide the following company information:
 - Company name
 - Customer ID Number
 - Shipping address
 - Billing address
 - First and last name of person ordering parts
 - Telephone number
 - Purchase order number
6. Provide definitive shipping instructions.

HOW TO USE THIS MANUAL

Any claim for loss or damage to a shipment in transit should be filed promptly with the transportation company making the delivery. Shipments will be complete unless the packing list or order acknowledgement indicates items back ordered.

If parts received are suspected to be incorrect or defective, please contact the TENNANT representative from whom you ordered the part. They will give authorization for return and/or handle replacement shipments when required.

SECTION 6

CONTENTS

	Page
Fig. 1 – Recommended General Maintenance Items	6-2
Fig. 2 – Replacement Brushes	6-3
Fig. 3 – Main Frame Group	6-4
Fig. 4 – Motor, Sheaves and Cover Group	6-6
Fig. 5 – Motor, Sheaves and Cover Group	6-8
Fig. 6 – Battery and Charger Group	6-10
Fig. 7 – Brush Drive Group	6-12
Fig. 8 – Wheel Drive Group	6-14
Fig. 9 – Hopper Group	6-15
Fig. 10 – Vacuum Fan Group	6-16
Fig. 11 – Filter and Shaker Motor Group	6-17
Fig. 12 – Instrument Panel Group	6-18
Fig. 13 – Instrument Panel Group	6-19
Fig. 14 – Label Group	6-20
Fig. 15 – Label Group	6-21
Fig. 16 – Wire Harnesses Group	6-22
Fig. 17 – Wire Harnesses Group	6-24
Fig. 18 – Wire Harnesses Group	6-26

Fig. 1 – Recommended General Maintenance Items

Key	TENNANT Part No.	Machine Serial Number	Description	Qty.
▽	60027	(000000–)	Maintenance Kit, Skirts	1
▲	08057	(000000–)	Skirt and Flap Assembly, Rear	1
▲	08703	(000000–)	Retainer, Rear Seal	1
▲	28072	(000000–)	Skirt, Side	2
▲	28250	(000000–)	Retainer, Side Skirt	1
▲	28026	(000000–)	Retainer, Front Side Skirt	1
▲	28081	(000000–)	Lip Assembly, Pan	2
▲	28277-1	(000000–)	Seal, Foam Rubber	1
▲	28277-2	(000000–)	Seal, Foam Rubber	1
▲	28025	(000000–)	Retainer	1
▲	47037	(000000–)	Adhesive, 5 oz (150cc) Tube	1
▽	01780	(000000-005999)	Performance Package, Squeegee	1
▲	03856	(000000-005999)	Blade, Rear Squeegee	1
▲	01657	(000000-005999)	Strip, Rear Backup	1
▲	63967	(000000-005999)	Blade, Front Squeegee	1

Fig. 2 – Replacement Brushes

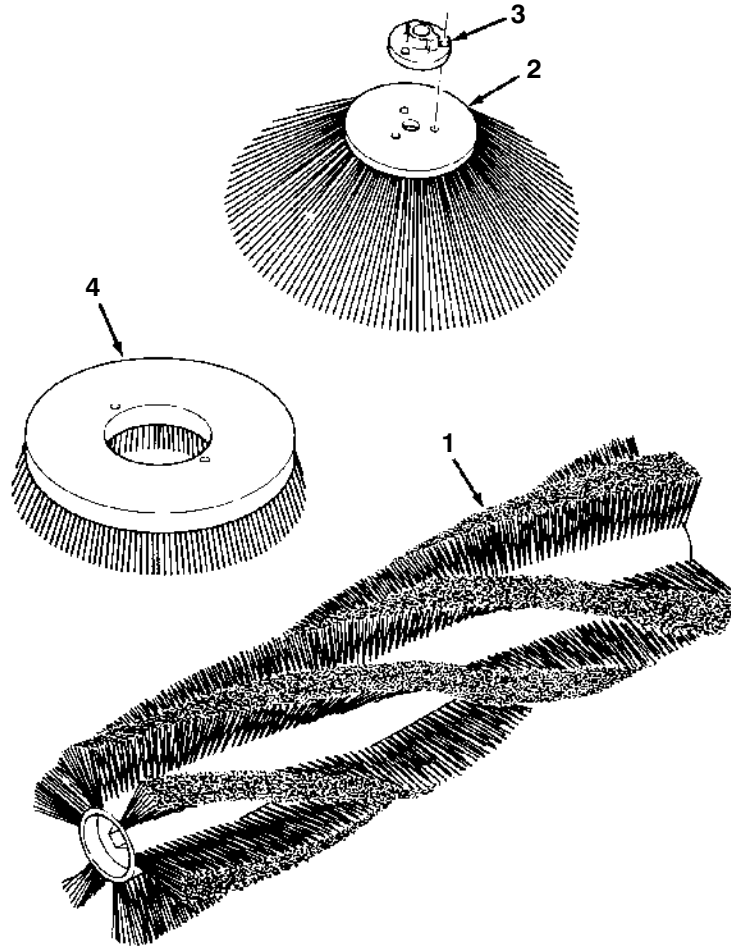

02842

Key	TENNANT Part No.	Machine Serial Number	Description	Qty.
1	28002	(000000–)	Main Brush, 6 Row, Wire and Fiber	1
1	28006	(000000–)	Main Brush, 6 Row, Union Mix	1
1	28006N	(000000–)	Main Brush, 6 Row, Nylon	1
1	28007P	(000000–)	Main Brush, 6 Row, Polypropylene	1
1	28172	(000000–)	Main Brush, 18 Row, Natural Fiber	1
1	28234	(000000–)	Main Brush, 50 Row, Tampico	1
1	28235	(000000–)	Main Brush, 18 Row, Wire and Fiber	1
1	28660	(000000–)	Main Brush, 6 Row, Bright Wire	1
1	29006	(000000–)	Main Brush, Scrubbing 18 Row, Stainless Steel	1
1	29408	(000000–)	Main Brush, Scrubbing 24 Row, Polypropylene	1
∇	2	28096P	(000000–) Side Brush and Hub Assembly, Polypropylene	1
▲	3	45154	(000000–) Hub, Side Brush	1
∇		28096N	(000000–) Side Brush and Hub Assembly, Perlon	1
▲		45154	(000000–) Hub, Side Brush	1
4	29406	(000000–)	Side Brush, Scrubbing, Polypropylene	1

Fig. 3 – Main Frame Group

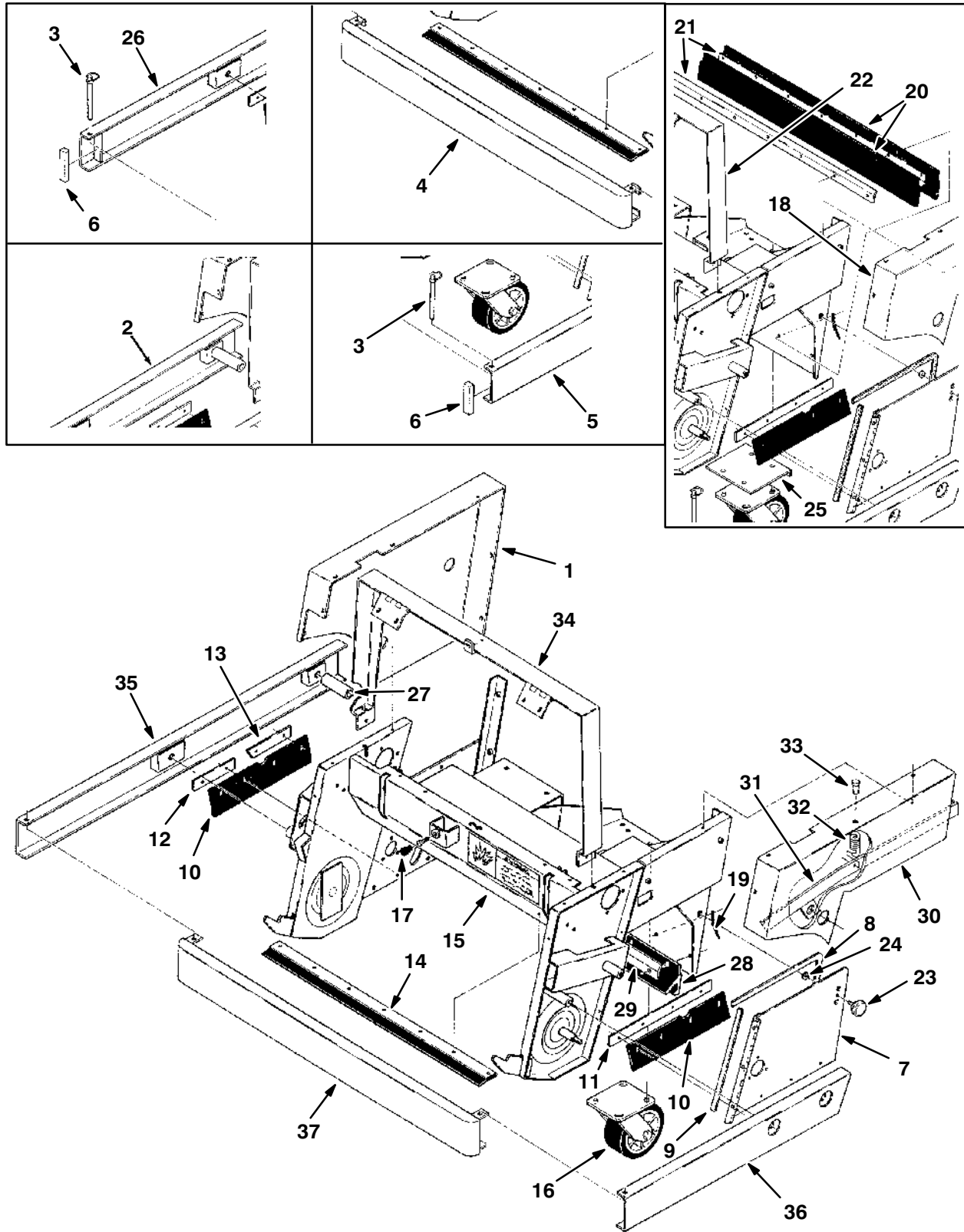

Fig. 3 – Main Frame Group

Key	TENNANT Part No.	Machine Serial Number	Description	Qty.
1	01235	(000000–)	Cover, Right Side	1
2	01246	(000000–001599)	Bumper, R.H.	1
3	01317	(000000–007142)	Pin,Pivot 3.5Lg	2
4	61324	(000000–007142)	Replacement Kit, Front Bumper F/01327	1
5	01247	(000000–007142)	Bumper,Weldmt Left	1
6	28988–1	(000000–007142)	Seal,Foam Rbr, .50.75W 3.0L	2
▽ 7	06469	(000000–)	Door Assy	1
▲ 8	28277–1	(000000–)	Seal,Foam Rbr, .19.38W 19.3L	1
▲ 9	28277–2	(000000–)	Seal,Foam Rbr, .19.38W 9.6L	1
10	28072	(000000–)	Skirt,Side	2
11	28025	(000000–)	Retainer	1
12	28026	(000000–)	Retainer,Skirt Lt Side Frt	1
13	28250	(000000–)	Retainer,Skirt Rt Side Rear	1
14	28081	(000000–)	Lip Assy,Pan	1
15	12063	(000000–)	Frame, Main W/Label	1
16	18645	(000000–007335)	Caster–5”Dia.	1
16	65548	(007336–)	Caster–5”Dia.	1
17	01318	(000000–)	Tip,Rubber	1
18	01234	(000000–005999)	Cover Wldt	1
19	28499	(000000–)	Chain,Sash#35 ,6 Links L	1
20	28071	(000000–002674)	Skirt,Rear	2
21	01131	(000000–002674)	Retainer, Rear Seal	2
22	01166	(000000–005999)	Lintel Weldmt	1
23	29982	(000000–)	Knob,0.31–06,1.38Dia,Plastic	1
24	08156	(000000–)	Retainer, Screw	1
25	08087	(000000–002554)	Stiffener, Caster	1
26	10226	(001600–007142)	Bumper, R.H.	1
27	01251	(001600–)	Tube	1
28	08057	(002675–)	Skirt & Flap, Rear	1
29	08703	(002675–)	Retainer, Rear Seal	1
30	50938	(006000–)	Cover, Wldt Lh	1
31	50931	(006000–)	Lever Wldt, Brake	1
32	09480	(006000–)	Sprng,Tens,1.10Dx.15Wire 3.2Lg	1
33	41305	(006000–)	Pin, Clevis,0.37 Dia X 0.75 Lg	1
34	50711	(006000–)	Lintel Weldmt	1
35	61326	(007143–)	Bumper, R.H.	1
36	61327	(007143–)	Bumper, L.H.	1
37	61322	(007143–)	Bumper, Front	1

Fig. 4 – Motor, Sheaves and Cover Group

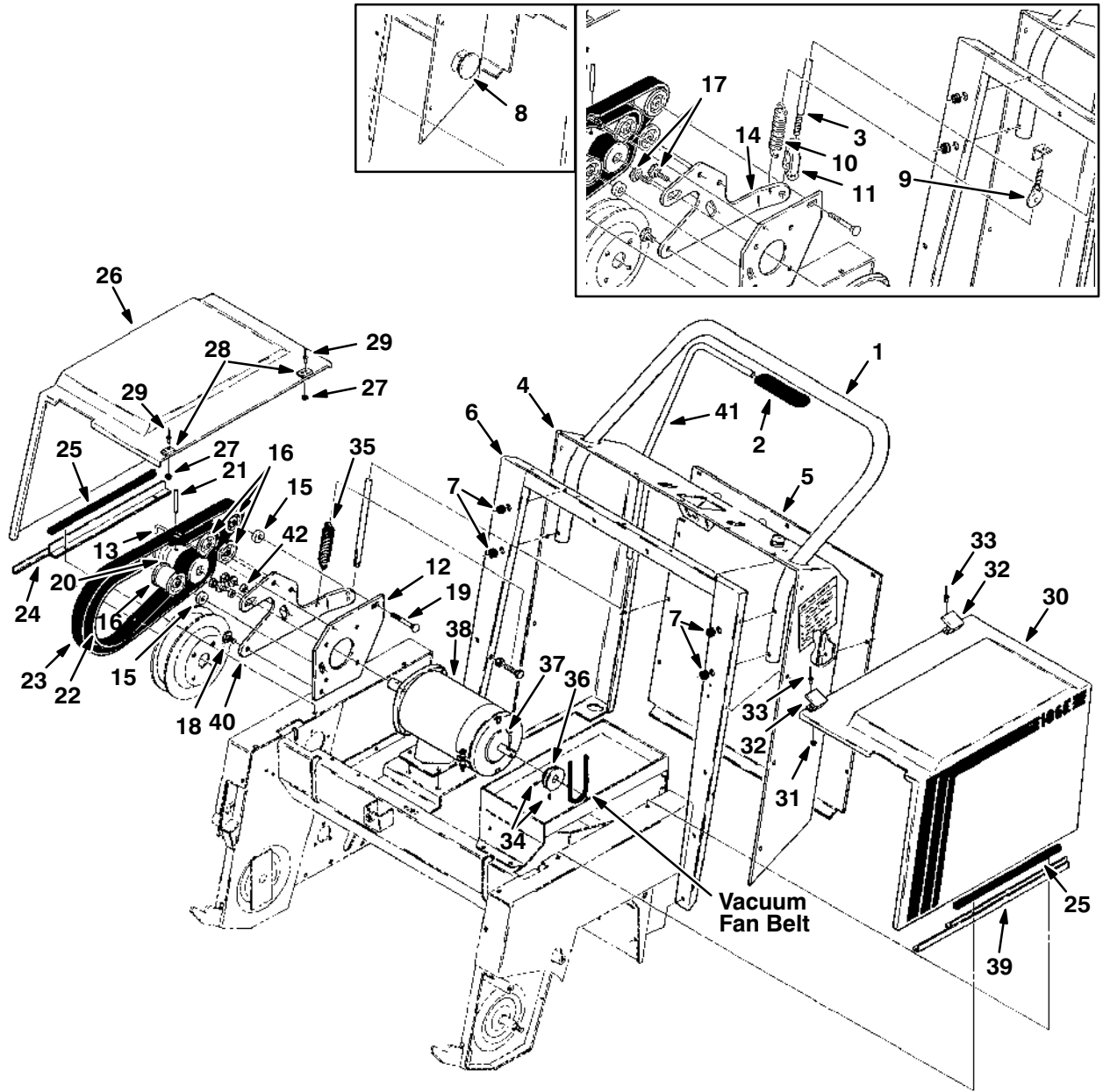

Fig. 4 – Motor, Sheaves and Cover Group

Key	TENNANT Part No.	Machine Serial Number	Description	Qty.
1	01195	(000000–005999)	Handle	1
2	08086	(000000–005999)	Grip, Handle	1
3	01271	(000000–002506)	Rod, Directional Control	1
4	12067	(000000–004368)	Panel and Label Assembly, Instrument	1
4	30200	(004369–005999)	Panel and Label Assembly, Instrument	1
5	01198	(000000–005999)	Cover, Back	1
6	01142	(000000–005999)	Support, Rear	1
7	10632–12	(000000–005999)	Grommet	4
8	82747	(000000–002289)	Plugbutton	1
9	22328	(000000–001474)	Eyebolt	1
10	01274	(000000–001474)	Spring, Tension	1
11	14330	(000000–002506)	Yoke, Adjustable	1
12	25921	(000000–005999)	Plate, Directional Pivot	1
13	01134	(000000–005999)	Retainer, Belt	1
14	08041	(000000–002506)	Replacement Kit, Lever	1
15	01113	(000000–005999)	Spacer, Directional Plate	2
16	01199	(000000–005999)	Sheave, Idler	4
17	12966	(000000–003224)	Screw, Shoulder	2
18	01112	(000000–005999)	Screw, Shoulder	1
19	01150	(000000–005999)	Bolt, Carriage	1
20	01115	(000000–005999)	Sheave, Combination	1
21	11398	(000000–005999)	Pin, Roll	1
22	01119	(000000–005999)	Belt, Flat, Forward	1
23	01120	(000000–005999)	Belt, Flat, Reverse	1
24	01194	(000000–005999)	Retainer, Cover, R.H.	1
25	62170–1	(000000–005999)	Molding, Rigid	2
▽ 26	06464	(000000–005999)	Cover Assembly, R.H.	1
▲ 27	64757	(000000–005999)	Bumper, Rubber	2
▲ 28	01144	(000000–005999)	Closure, Edge Mating	2
▲ 29	01335	(000000–005999)	Rivet, Soft	4
▽ 30	06468	(000000–005999)	Cover Assembly, L.H.	1
▲ 31	64757	(000000–005999)	Bumper, Rubber	2
▲ 32	01144	(000000–005999)	Closure, Edge Mating	2
▲ 33	01335	(000000–005999)	Rivet, Soft	4
34	46820	(000000–005999)	Screw, Nylon Set	2
35	29545	(001475–005999)	Spring, Tension	1
36	01104	(000000–005999)	Sheave	1
37	00500–4	(000000–005999)	Key, Woodruff	1
▽ 38	01192	(000000–005999)	Motor, Electric	1
▲	01739	(000000–005999)	Brush Kit	1
▲	01740	(000000–005999)	Spring, Brush	4
39	01331	(000000–005999)	Retainer, Cover, L.H.	1
40	08037	(002507–005999)	Lever, Directional Control	1
41	08036	(002507–005999)	Rod, Directional	1
42	12955	(003225–005999)	Sleeve	2

Fig. 5 – Motor, Sheaves and Cover Group

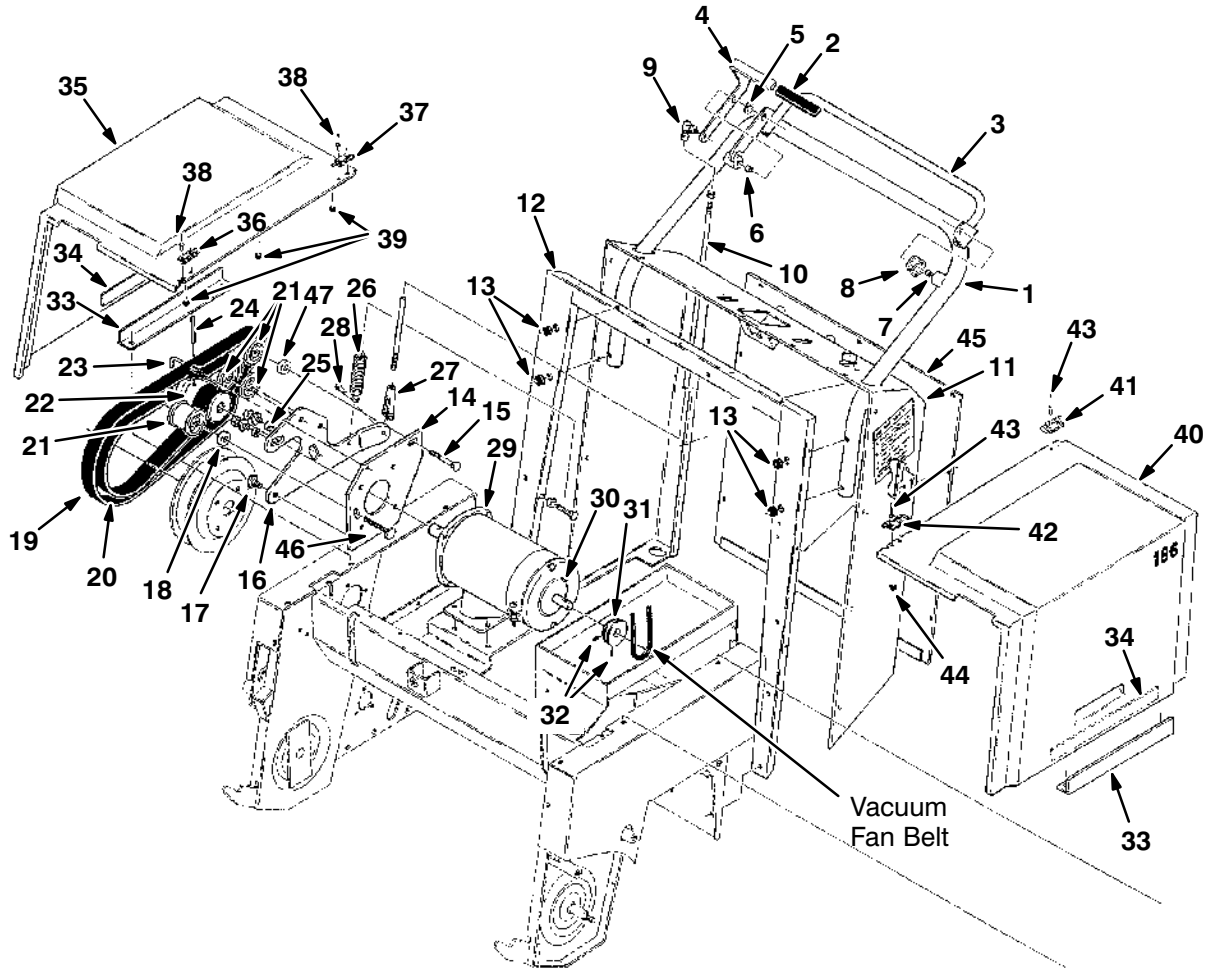

Fig. 5 – Motor, Sheaves and Cover Group

Key	TENNANT Part No.	Machine Serial Number	Description	Qty.
1	09433	(006000–)	Handle	1
2	87246	(006000–)	Grip, Handle	1
3	09400	(006000–)	Handle, Forward	1
4	09408	(006000–)	Handle, Reverse	1
5	52508	(006000–)	Washer, Wavy Spring	1
6	50821	(006000–)	Sleeve	1
7	50936	(006000–)	Sleeve	1
8	50910	(006000–)	Spring, Torsion	1
9	50909	(006000–)	Balljoint	1
10	09473	(006000–)	Rod, Control	1
11	41286	(006000–)	Panel and Label Assembly, Instrument	1
12	01142	(006000–)	Support, Rear	1
13	10632–12	(006000–)	Grommet	4
14	25921	(006000–)	Plate, Directional Pivot	1
15	01150	(006000–)	Bolt, Carriage	1
16	08037	(006000–)	Lever, Directional Control	1
17	01112	(006000–)	Screw, Shoulder	1
18	01113	(006000–)	Spacer, Directional Plate	1
19	01119	(006000–)	Belt, Flat, Forward	1
20	01120	(006000–)	Belt, Flat, Reverse	1
21	01199	(006000–)	Sheave, Idler	4
22	01115	(006000–)	Sheave, Combination	1
23	01134	(006000–)	Retainer, Belt	1
24	11398	(006000–)	Pin, Roll	1
25	12955	(006000–)	Sleeve	2
26	29545	(006000–)	Spring, Tension	1
27	58311	(006000–)	Clevis	1
28	69582	(006000–)	Pin, Clevis	1
▽ 29	01192	(006000–)	Motor, Electric	1
▲	01739	(006000–)	Brush Kit	1
▲	01740	(006000–)	Spring, Brush	4
30	00500–4	(006000–)	Key, Woodruff	1
31	01104	(006000–)	Sheave	1
32	46820	(006000–)	Screw, Nylon Set	2
33	09494	(006000–)	Angle, Stop	2
34	09367	(006000–)	Magnetic Strip	2
▽ 35	61063	(006000–)	Cover Assembly, R.H.	1
▲ 36	50832	(006000–)	Hinge, Pull Pin L.H.	1
▲ 37	50835	(006000–)	Hinge, Pull Pin R.H.	1
▲ 38	01335	(006000–)	Rivet, Soft	4
▲ 39	64757	(006000–)	Bumper, Rubber	3
▽ 40	61067	(006000–)	Cover Assembly, L.H.	1
▲ 41	50832	(006000–)	Hinge, Pull Pin L.H.	1
▲ 42	50835	(006000–)	Hinge, Pull Pin R.H.	1
▲ 43	01335	(006000–)	Rivet, Soft	4
▲ 44	64757	(006000–)	Bumper, Rubber	3
45	50744	(006000–)	Cover, Back	1
46	30205	(006000–)	Screw, Leveller	1
47	70326	(006000–)	Spacer, Directional Plate	1

Fig. 6 – Battery and Charger Group

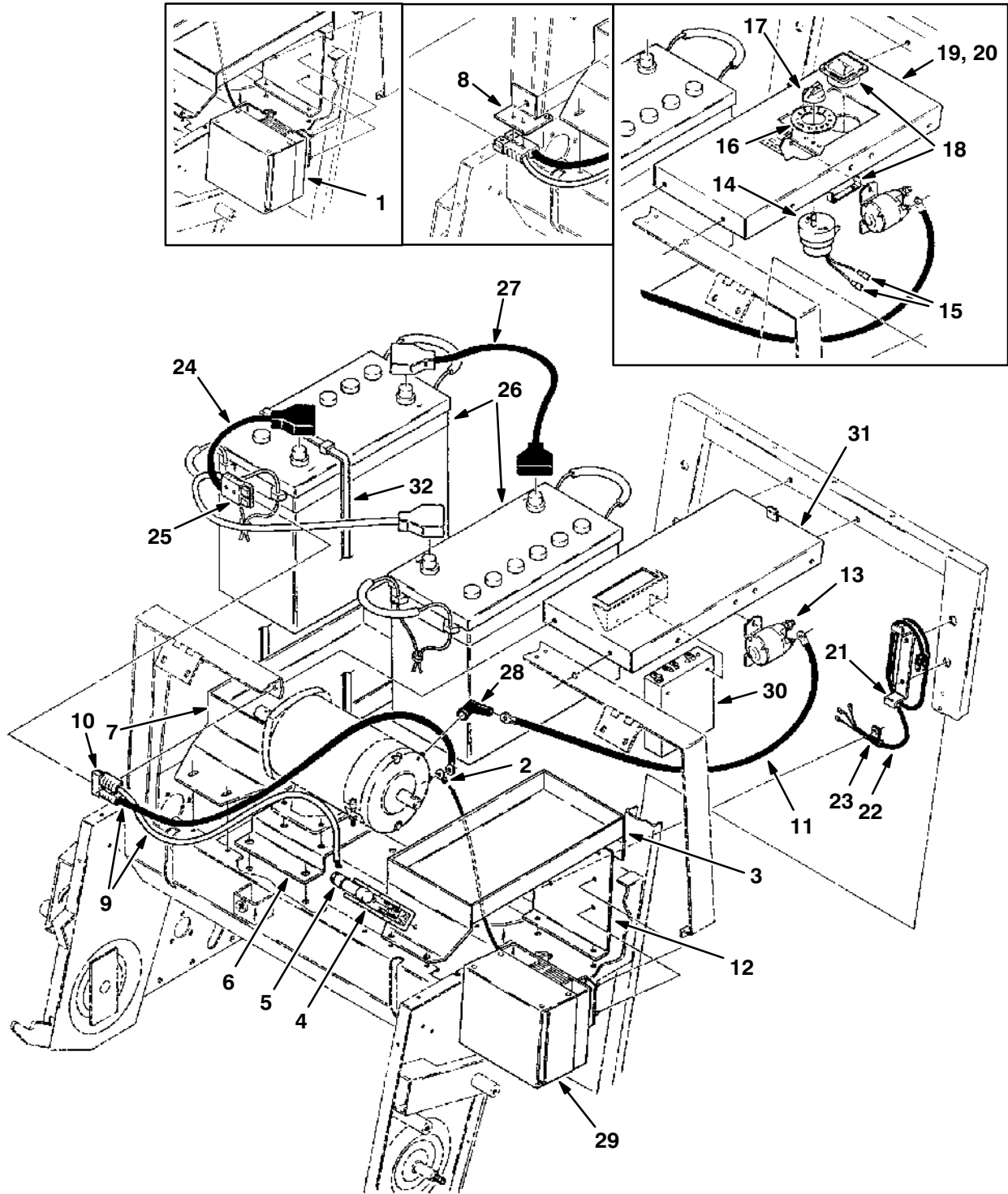
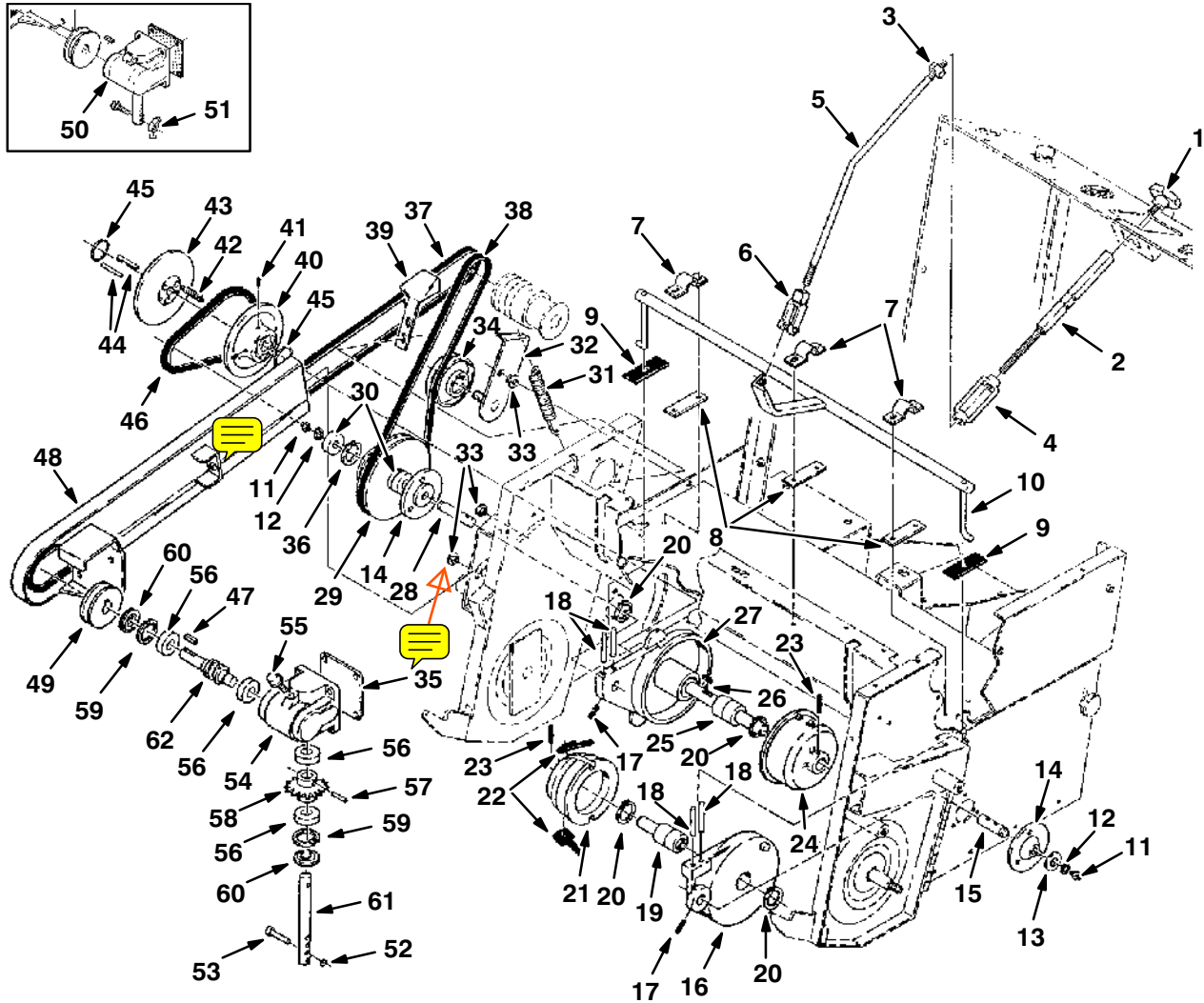

Fig. 6 – Battery and Charger Group

Key	TENNANT Part No.	Machine Serial Number	Description	Qty.	
1	60515	(000000–005999)	Replm Kit, Charger F/50708	1	
1	60519	(006000–006822)	Replm Kit, Charger F/50708	1	
2	44340	(000000–)	Terminal, Ring, .250 Stud,10&12Ga	1	
3	01098	(000000–)	Tray Wldt, Batt Lh	1	
4	32922	(000000–)	Fuseholder,	1	
5	04930	(000000–)	Fuse, 60A 250V	1	
6	01105	(000000–)	Bracket, Motor Mount	1	
7	01421	(000000–)	Tray Wldt, Batt Rh	1	
8	01324	(000000–002205)	Cable Mount	1	
▽	9	01379	(000000–)	Cable Assy, Battery	1
▲	10	24881	(000000–)	Connector, Andersn 50Amp,Gray	1
11	01094	(000000–)	Cable, Battery, 12.0Lg	1	
12	01101	(000000–)	Support, Battery Tray	1	
13	02424	(000000–)	Contact, 24Volt Dc	1	
14	61104	(000000–006822)	Switch, Timer12Hr 60Hz 120V	1	
15	50474	(000000–006822)	Term. Splice/Quick Disc.Male	2	
16	09796	(000000–005999)	Label Rep. By 41609	1	
16	41609	(006000–006822)	Label, Timer–60Hz Dual Scale	1	
17	61106	(000000–006822)	Knob, Pointer, Timer	1	
18	29688	(000000–006822)	Ammeter Charger	1	
19	12066	(000000–005999)	Brace, Center W/Label	1	
20	41289	(006000–006822)	Channel Wldt,186E W/Label	1	
21	01377	(000000–)	Bracket, Cord	1	
22	01376	(000000–)	Cord,Charger	1	
23	46236	(000000–005999)	Clamp–Cable,0.25 Dia 0.56Wth	1	
23	40678	(006000–)	Clamp, Cable .44D .62 Wide	1	
▽	24	01373	(000000–)	Cable Assy,Batt(E)	1
▲	25	24881	(000000–)	Connector, Andersn 50Amp,Gray	1
26	01537	(000000–)	Battery,12V–140Ah Wet Custmr	2	
27	01368	(000000–)	Wire Assy, 24.0L 6Ga	1	
28	02076	(000000–)	Cover, Terminal	1	
29	50050	(006823–)	Charger, 24V, 60 Hz 120Vac	1	
30	50049	(006823–)	Control Box, 24V Charger	1	
31	60523	(006823–)	Channel Wldt, Center	1	
32	32815	(000000–)	Tie, Cable 8.00D Max28.25Lg	4	

STANDARD PARTS

Fig. 7 – Brush Drive Group



03053

Key	TENNANT Part No.	Machine Serial Number	Description	Qty.
1	01139	(000000-)	Handle, Tee	1
2	01138	(000000-)	Handle, Brush Lift	1
3	39562	(000000-)	Nut, Hex, L.H.	1
4	40352	(000000-)	Turnbuckle	1
5	01141	(000000-)	Rod, Brush Lift	1
6	14330	(000000-)	Yoke, Adjustable	1
7	28074	(000000-)	Clamp, Conduit	3
8	28066	(000000-)	Strip	3
9	29005	(000000-)	Seal	2
10	08147	(000000-)	Shaft, Brush Lift	1
11	07259	(000000-)	Fitting, Grease	2
12	18136	(000000-)	Ring, Retaining	2
13	28862	(000000-)	Washer, Thrust	1
14	01236	(000000-)	Bushing	2
15	28850A	(000000-)	Shaft, Short	1
16	28841	(000000-)	Arm	1
17	26103	(000000-)	Pin, Roll	2
18	20050	(000000-)	Pin, Roll	4
19	28868	(000000-)	Bearing and Shaft	1
20	23217	(000000-)	Ring, Retaining	4

Key	TENNANT Part No.	Machine Serial Number	Description	Qty.
21	28977	(000000-)	Plug Assembly	1
22	28852	(000000-)	Finger	2
23	26239	(000000-)	Pin, Roll	2
24	28976	(000000-)	Plug and Pin Assembly, Drive	1
25	28867	(000000-)	Bearing and Shaft	1
26	00911	(000000-)	Key, Square	1
27	28840	(000000-)	Arm	1
28	28849-1	(000000-)	Shaft, Long	1
29	28845A	(000000-)	Sheave, Step	1
30	28010	(000000-)	Bearing, Ball	2
31	26212	(000000-)	Spring, Tension	1
32	01058	(000000-)	Arm and Shaft Assembly, Idler	1
33	01047	(000000-)	Retainer	3
34	28223	(000000-002277)	Pulley Assembly	1
34	06651	(002278-)	Pulley Assembly	1
35	28078	(000000-)	Gasket	1
36	01513	(000000-)	Ring, Retaining	1
37	28712	(000000-)	V-Belt	1
38	28714	(000000-)	V-Belt	1
39	08155	(000000-)	Guide, Belt	1
▽	28979	(000000-)	Sheave Assembly, Adjustable	1
▲	40 18125	(000000-)	Sheave Half, Inner	1
▲	41 57496	(000000-)	Screw, Nylon Set	2
▲	42 28387	(000000-)	Spring, Tension	3
▲	43 28949	(000000-)	Sheave Half, Outer	1
▲	44 18276	(000000-)	Pin, Dowel	2
▲	45 28388	(000000-)	Retainer	2
46	28168	(000000-)	V-Belt	1
47	00911	(000000-)	Key, Square	1
48	01500	(000000-)	Arm, Side Sweep	1
49	28121	(000000-)	Sheave	1
▽	50 94150	(000000-002468)	Gearbox, Reducer (Replaced by 06662)	1
▲	94149	(000000-002468)	Plug, Breather	1
▲	94413	(000000-002468)	Seal, Oil	2
51	26509	(000000- xxxxxx)	Nut, Wing	1
52	49708	(xxxxxx-)	Ring, Split	1
53	15173	(xxxxxx-)	Pin, Clevis	1
▽	54 06662	(002469-)	Reducer Assembly	1
▲	55 07316-15	(002469-)	Breather	1
▲	56 28010	(002469-)	Bearing	4
▲	57 28144	(002469-)	Pin, Roll	1
▲	58 28195	(002469-)	Gear	1
▲	59 01513	(002469-)	Ring, Retaining	2
▲	60 28084	(002469-)	Seal, Oil	2
▲	61 28041	(002469-)	Shaft, Reducer	1
▲	62 28194	(002469-)	Worm	1

Fig. 8 – Wheel Drive Group

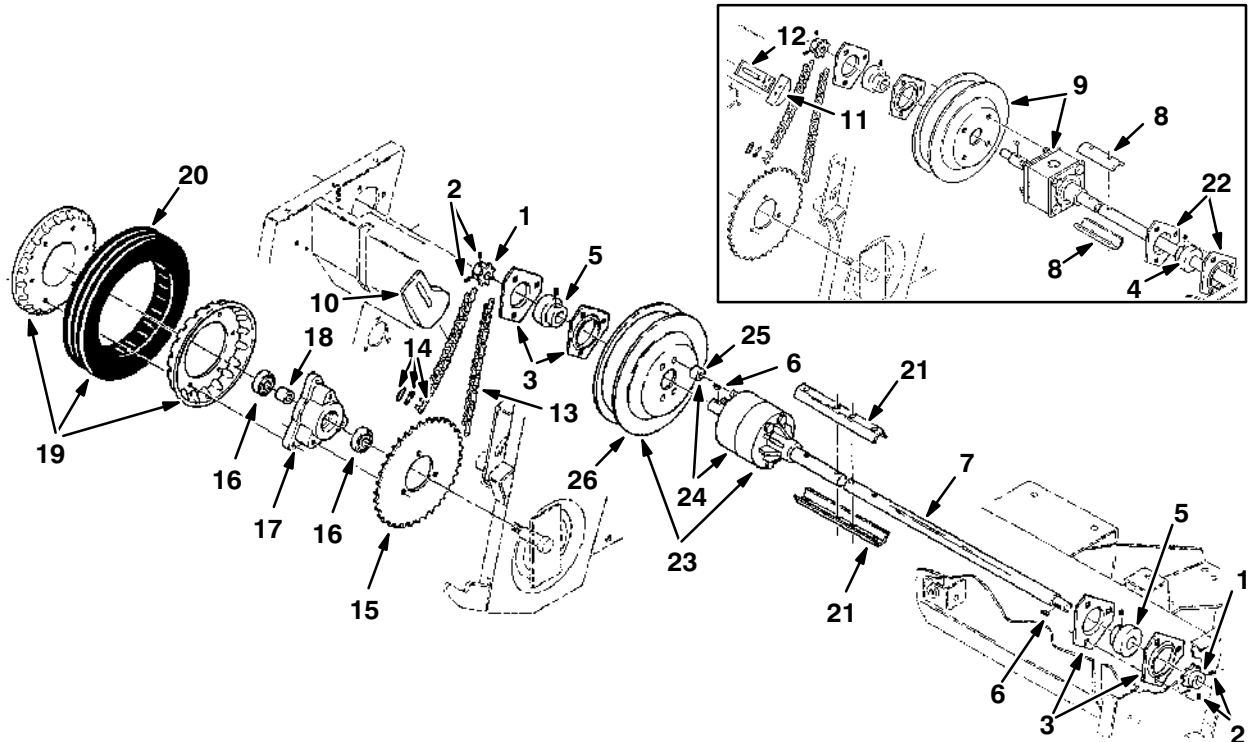

03051

Key	TENNANT Part No.	Machine Serial Number	Description	Qty
1	30175	(000000-004428)	Sprocket Replacment Kit	2
1	30174	(004429-)	Sprocket 8T41	2
2	20634	(000000-004428)	Scr-Set 10-24X0.25 Nylon Loc	4
2	57496	(004429-)	Scr-Set .25-20X0.31 Nylon Loc	4
3	51137	(000000-)	Flange,Brg,3 Hole, Pnt.	4
4	25887	(000000-002566)	Bearing, .750 Bore	1
5	25887	(000000-)	Bearing, .750 Bore	2
6	00500-1	(000000-)	Key-Wdruff 0.09 0.50	2
7	08152	(000000-)	Countershaft	1
8	01362	(000000-002566)	Coupling,Half	2
9	12990	(000000-003551)	Differential Asy	1
10	08142	(003552-)	Chain Guide	2
11	01217	(000000-003551)	Guide	2
12	01200	(000000-003551)	Tightener	2
∇ 13	61414	(000000-)	Chain and Link Assembly	2
▲ 14	28272	(000000-)	Link,Rlr.Chain #41	2
15	28865	(000000-)	Sprkt,#41, 45T Plate Sprocket	2
16	28010	(000000-)	Bearing-Ball,0.62B 1.38D 0.43W	4
17	01288	(000000-)	Hub, Wheel-Machined	2
18	28014A	(000000-)	Sleeve, .657B .88D .630Cr.Cad	2
∇ 19	28061	(000000-)	Wheel & Tire Assy	2
▲ 20	28546	(000000-)	Tire,10X2.00 Ehs Semi-Pneu.	1
21	08145	(002567-)	Coupling,Half	2
22	51137	(000000-002566)	Flange, Brg, 3 Hole, Pnt.	2
∇ 23	30148	(003552-)	Differential & Sheave Assy	1
▲∇ 24	61291	(003552-)	Rplmt Kit, Differential F/12960	1
▲▲ 25	61289	(003552-)	Sleeve	4
▲ 26	30147	(003552-)	Sheave, Flat Belt	1

Fig. 9 – Hopper Group

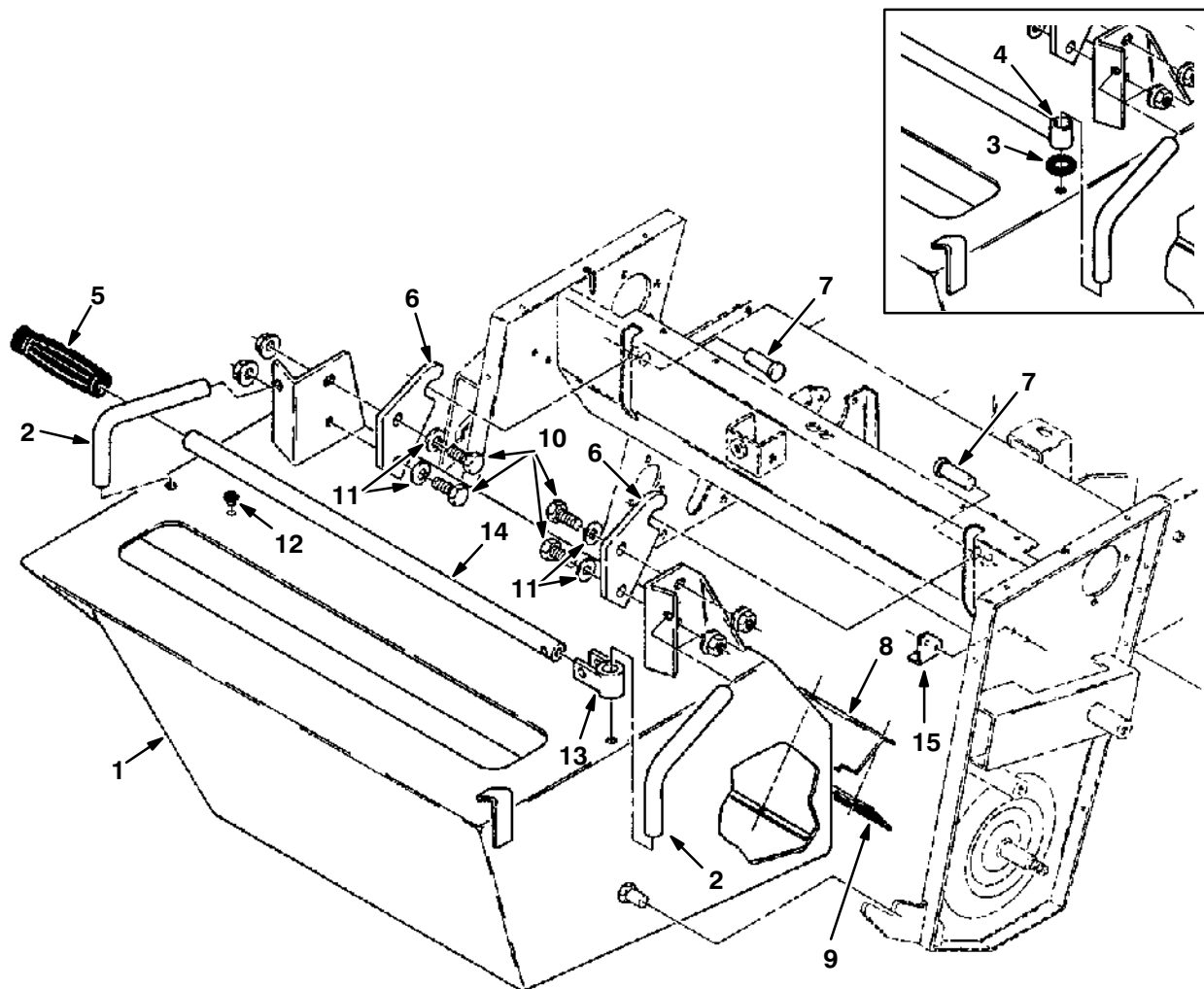

03048

Key	TENNANT Part No.	Machine Serial Number	Description	Qty.
1	01121	(000000-)	Hopper	1
2	01157	(000000-)	Handle, Hopper Lift	2
3	01316	(000000-003453)	Washer, Rubber	1
4	12764	(000000-003453)	Handle Lift Replacement Kit	1
5	03292B	(000000-)	Grip, Handle	1
6	01132	(000000-)	Plate, Hopper Catch	2
7	01272	(000000-)	Pin, Clevis	2
8	31025	(000000-)	Retainer, Lip	1
9	28081	(000000-)	Lip Assembly, Pan	1
10	41620	(000000-)	Screw, Hex, G8	4
11	41186	(000000-)	Washer, Belleville	4
12	51787	(000000-)	Bumper, Rubber	1
13	12768	(003454-)	Knuckle, Handle	1
14	12769	(003454-)	Handle, Lift	1
15	61123	(000000-)	Stop, Angle	1

Fig. 10 – Vacuum Fan Group

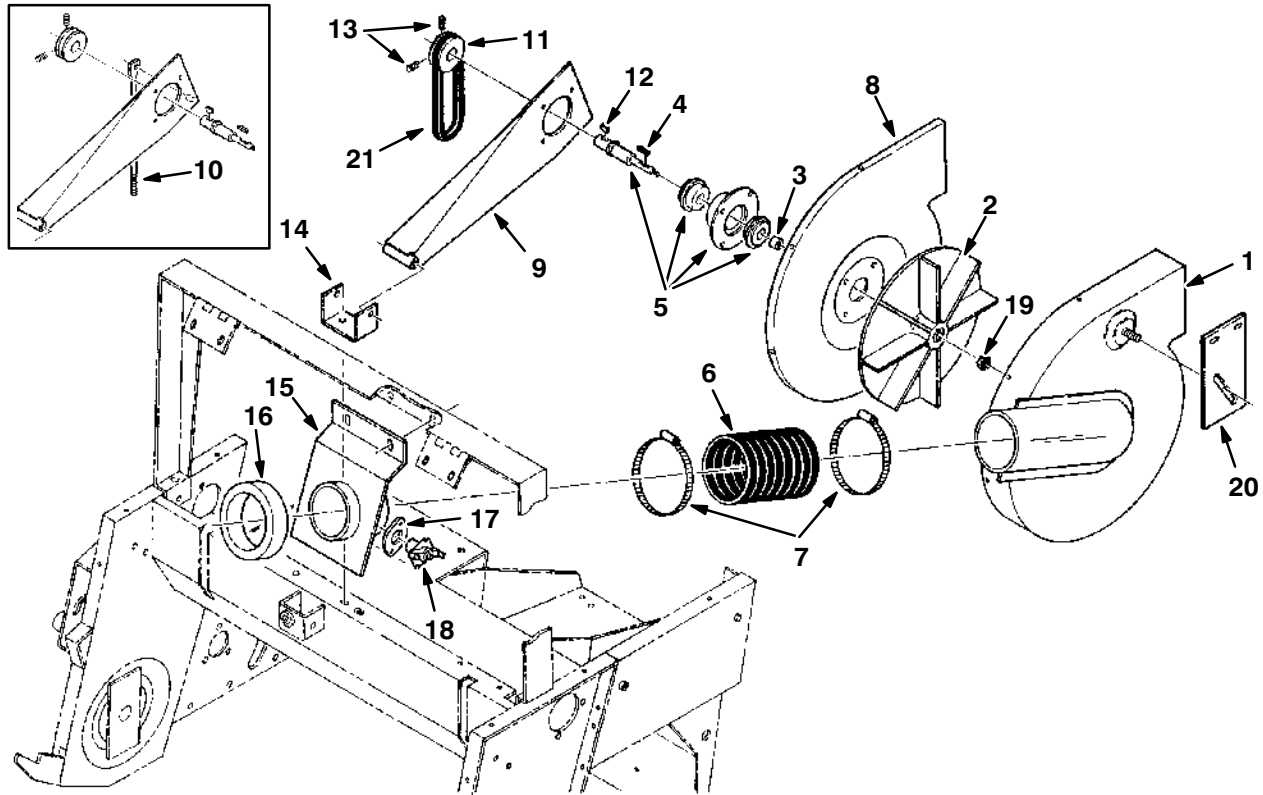

03058

Key	TENNANT Part No.	Machine Serial Number	Description	Qty.
1	10352	(000000–)	Housing, Vacuum Fan	1
2	08143	(000000–)	Impeller	1
3	10362	(000000–)	Sleeve	1
4	00960	(000000–)	Key, Square	1
5	16934	(000000–)	Shaft, Bearing and Flange Assembly	1
6	23481	(000000–)	Hose	1
7	23498	(000000–)	Clamp, Worm Drive	2
8	02221	(000000–)	Plate, Housing Backing	1
9	01188	(000000–)	Arm, Fan Mount	1
10	01255	(000000–002252)	Rod, Adjustment	1
11	01104	(000000–)	Sheave	1
12	00500–4	(000000–)	Key, Woodruff	1
13	46820	(000000–)	Screw, Nylon Set	2
14	01096	(000000–)	Bracket, Fan Pivot	1
15	01184	(000000–005999)	Adaptor, Filter To Fan	1
15	41292	(006000–)	Adaptor, Filter To Fan	1
16	47069	(000000–)	Sleeve	1
17	82733	(000000–)	Gasket, Thermostat	1
18	02712	(000000–)	Thermostat, Sealed	1
19	87299	(000000–)	Nut, Flex Lock	1
20	10224	(002253–)	Plate, Backing	1
21	28755	(000000–005999)	V-Belt	1
21	60470	(006000–)	V-Belt	1

Fig. 11 – Filter and Shaker Motor Group

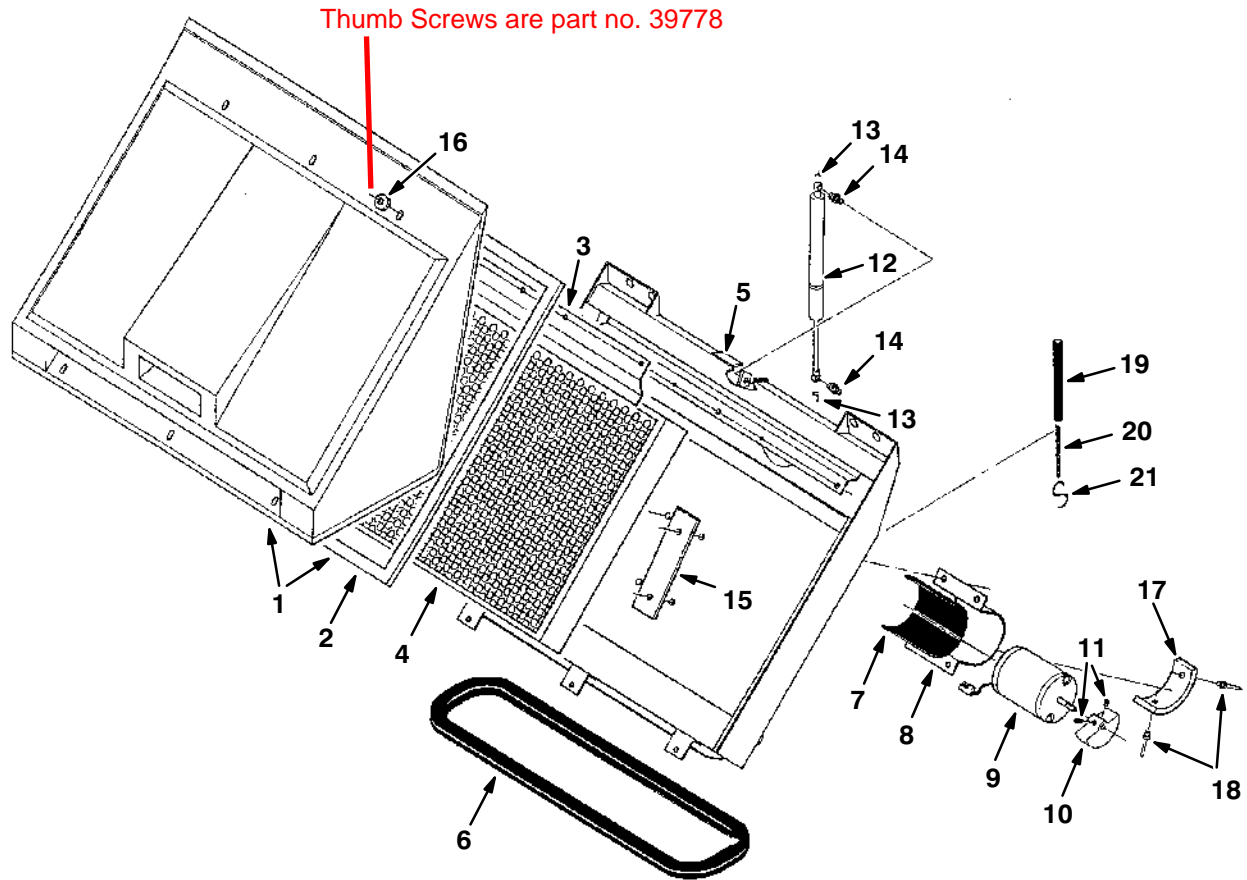

03056

Key	TENNANT Part No.	Machine Serial Number	Description	Qty.
▽ 1	06477	(000000–)	Cover, Filter Assembly	1
▲ 2	01064	(000000–)	Seal, Cover	1
3	01306	(000000–)	Bracket, Hold Down	1
▽ 4	87550	(000000–)	Filter Assembly	1
▲	65375	(000000–)	Gasket	1
5	41288	(000000–)	Box and Label Assembly, Filter	1
6	08157	(000000–)	Seal, Filter Opening	1
7	44893	(000000–)	Pad, Rubber	1
8	06659	(000000–)	Strap, Shaker Motor	1
9	54121	(000000–)	Motor, Electric	1
10	55130	(000000–)	Weight, Eccentric	1
11	20634	(000000–)	Screw, Nylon Set	2
12	31173	(000000–004143)	Spring, Gas	1
12	31172	(004144–)	Spring, Gas	1
13	64595	(000000–)	Clip, Safety	2
14	58494	(000000–)	Stud, Spring Ball	2
15	25920	(000000–)	Plate, Support Shaker	1
16	30169	(000000–)	Washer, Sealing	6
17	06660	(000000–)	Bumper, Shaker	1
18	01335	(000000–)	Rivet, Pop	2
19	01320	(000000–)	Sleeve, Vinyl	1
20	06121	(000000–)	Chain	1
21	01319	(000000–)	Hook, S	1

Fig. 12 – Instrument Panel Group

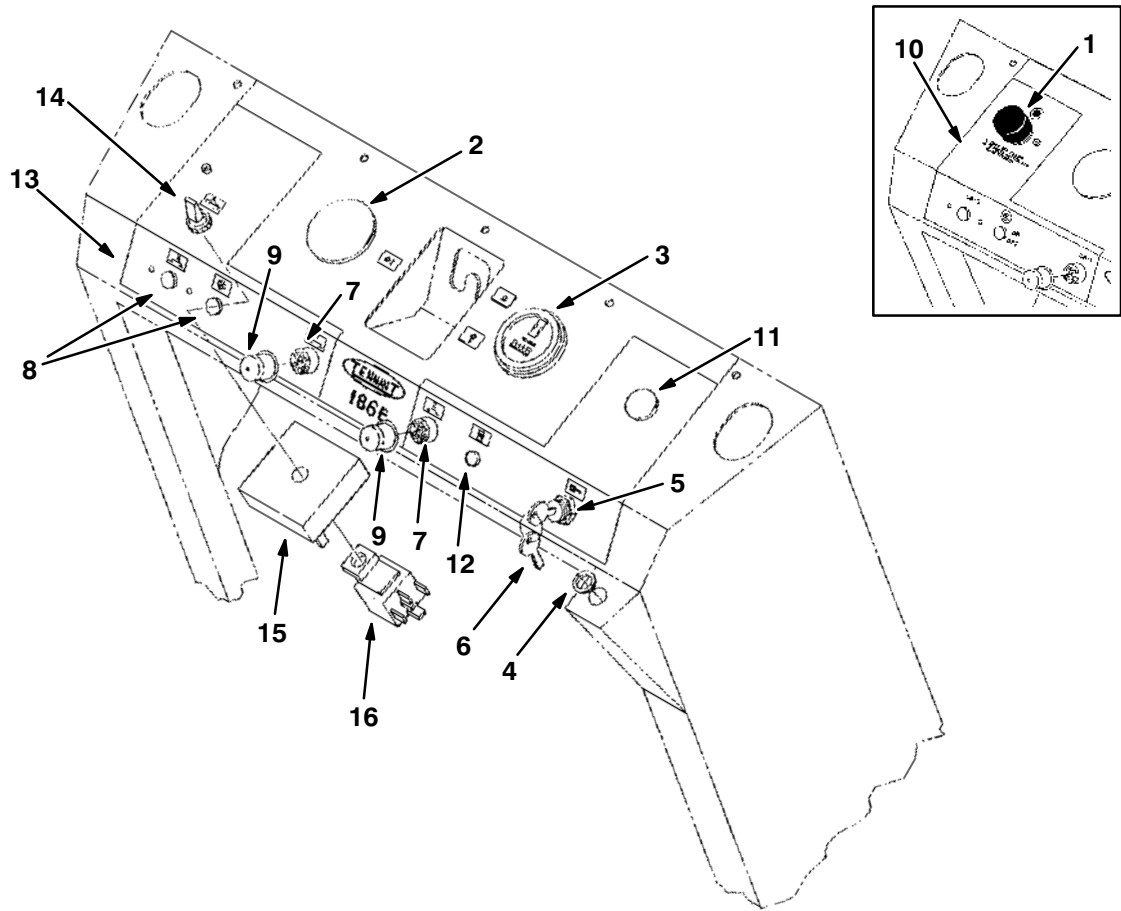

03045

Key	TENNANT Part No.	Machine Serial Number	Description	Qty.
1	44078	(000000–004368)	Switch, Push	1
2	82747	(000000–005999)	Plugbutton	1
3	34810	(000000–005999)	Meter, Hour	1
4	29991	(000000–005999)	Bushing, Nylon Flange	1
∇ 5	31203	(000000–005999)	Switch Assembly, Key	1
▲ 6	31204	(000000–005999)	Key, Switch	1
7	57803	(000000–005999)	Breaker, Circuit	2
8	56992	(000000–005999)	Plugbutton	2
9	57751	(000000–005999)	Boot, Circuit Breaker	2
10	12775	(000000–004368)	Label, Instrument Panel	1
11	01493	(000000–005999)	Plug, Plastic	1
12	01314	(000000–005999)	Plug, Plastic	1
13	09352	(004369–005999)	Label, Instrument Panel	1
14	63266	(004369–005999)	Switch	1
15	09338	(004369–005999)	Timer, Shaker	1
16	64730	(004369–005999)	Relay, SPDT	1

Fig. 13 – Instrument Panel Group

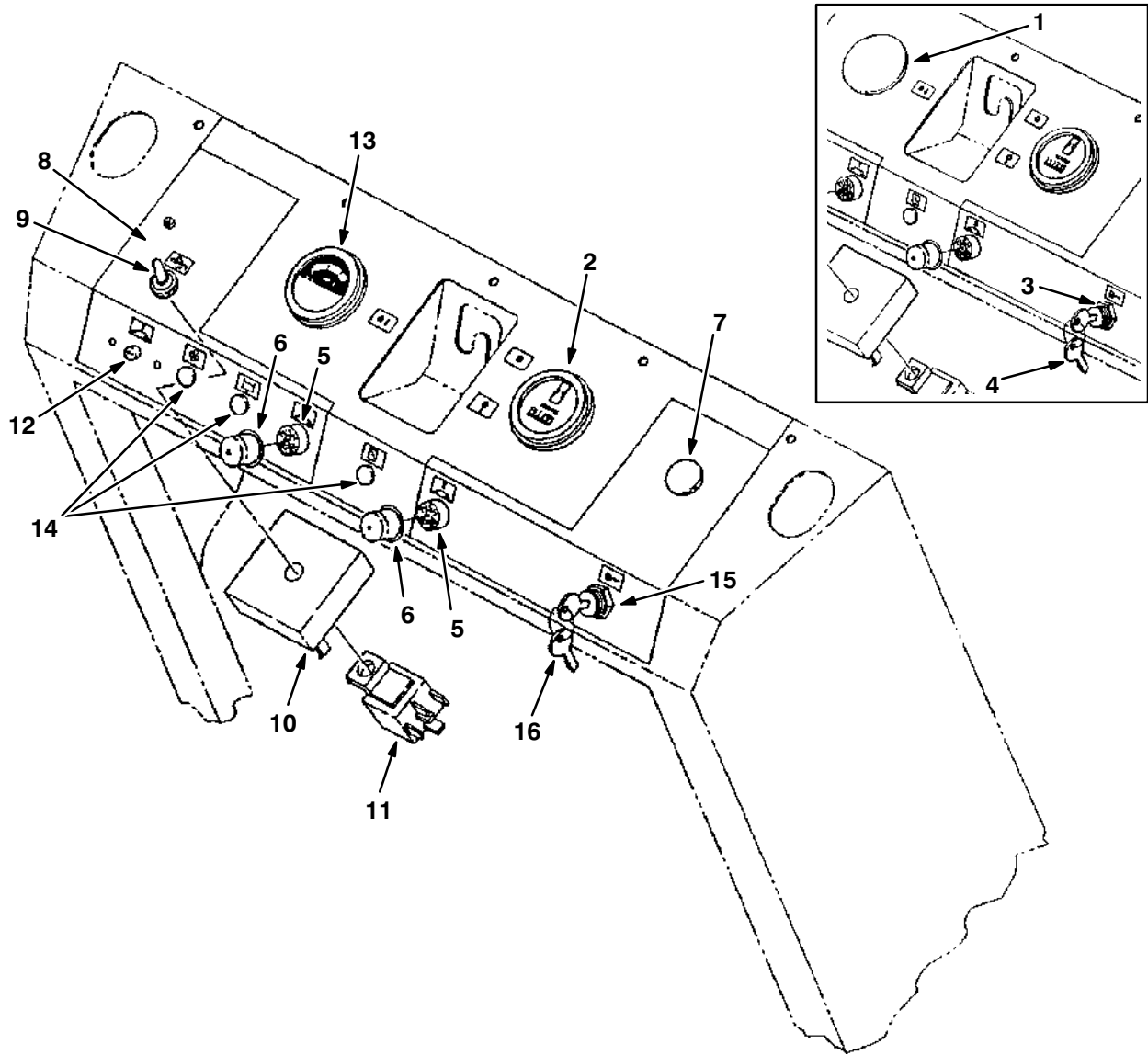

06432

Key	TENNANT Part No.	Machine Serial Number	Description	Qty.
1	82747	(006000-006822)	Plugbutton	1
2	34810	(006000-)	Meter, Hour	1
▽ 3	65374	(006000-009218)	Sealed Switch Assembly, Key	1
▲ 4	31204	(006000-009218)	Key, Switch	1
5	57803	(006000-)	Breaker, Circuit	2
6	57751	(006000-)	Boot, Circuit Breaker	2
7	01493	(006000-)	Plug, Plastic	1
8	50828	(006000-)	Label, Instrument Panel	1
9	70320	(006000-)	Switch	1
10	09338	(006000-)	Timer, Shaker	1
11	64730	(006000-)	Relay, SPDT	1
12	63030	(006000-)	Breaker, Circuit	1
13	60510	(006823-)	Meter, Volt 24V	1
14	56992	(006000-)	Plugbutton	3
▽ 15	70323	(009219-)	Sealed Switch Assembly, Key	1
▲ 16	21570	(009219-)	Key, Switch	1

Fig. 14 – Label Group

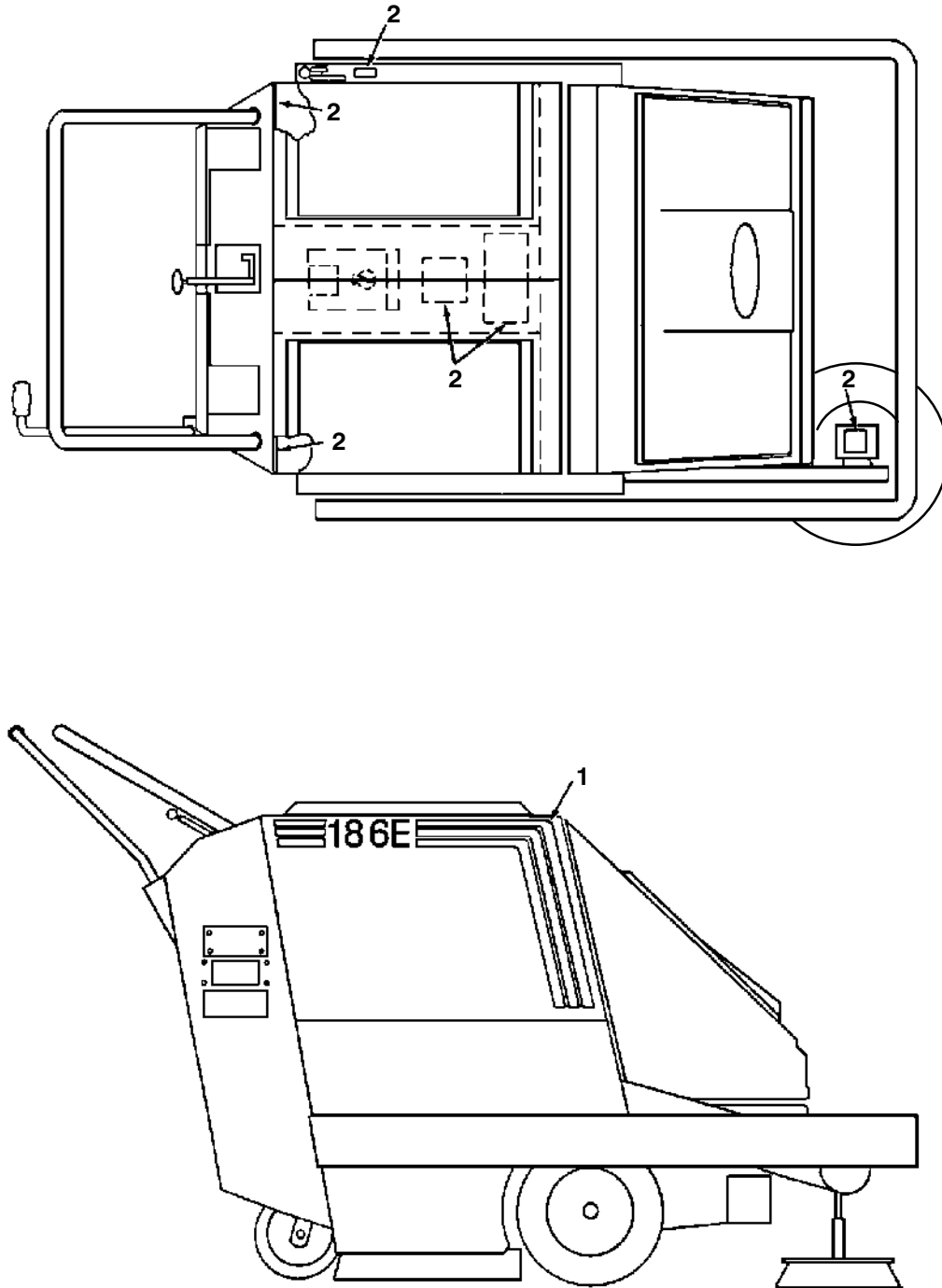

03102

Key	TENNANT Part No.	Machine Serial Number	Description	Qty.
1	30172	(000000–005999)	Label Kit, Striping	1
2	10232	(000000–005999)	Label Kit, Information and Hazard	1

Fig. 15 – Label Group

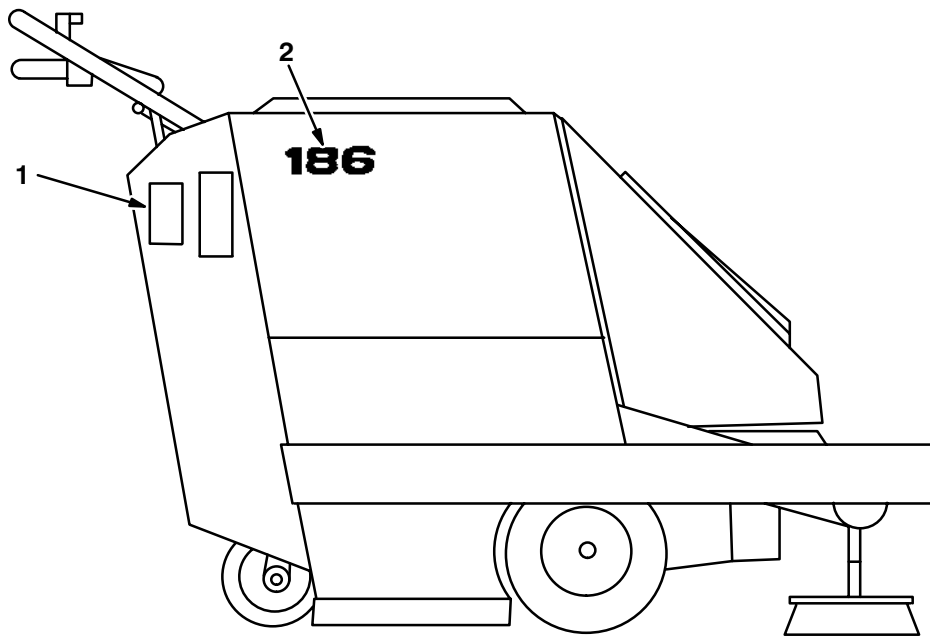
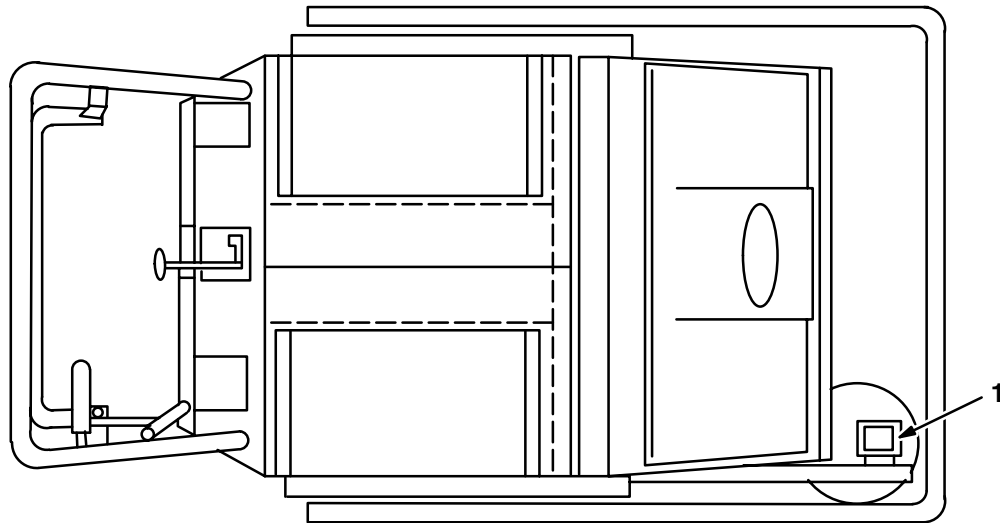

06434

Key	TENNANT Part No.	Machine Serial Number	Description	Qty.
1	50926	(006000–)	Label Kit, Information and Hazard	1
2	50843	(006000–)	Label, 186	1

Fig. 16 – Wire Harness Group

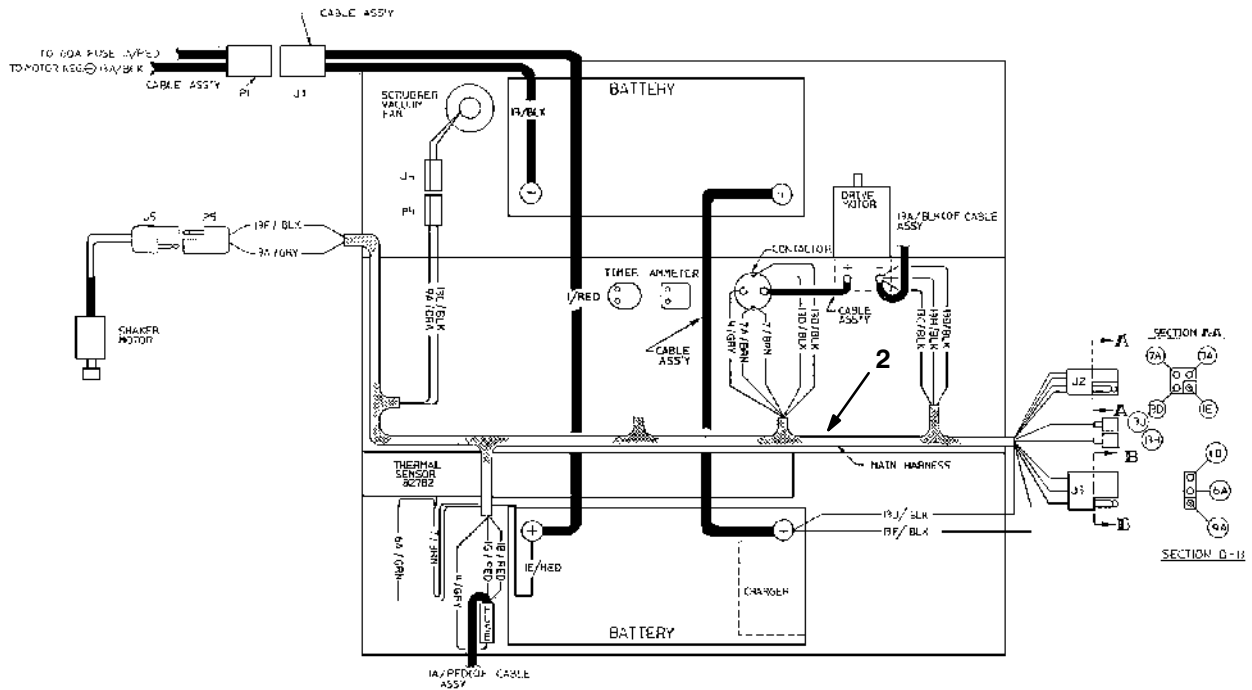
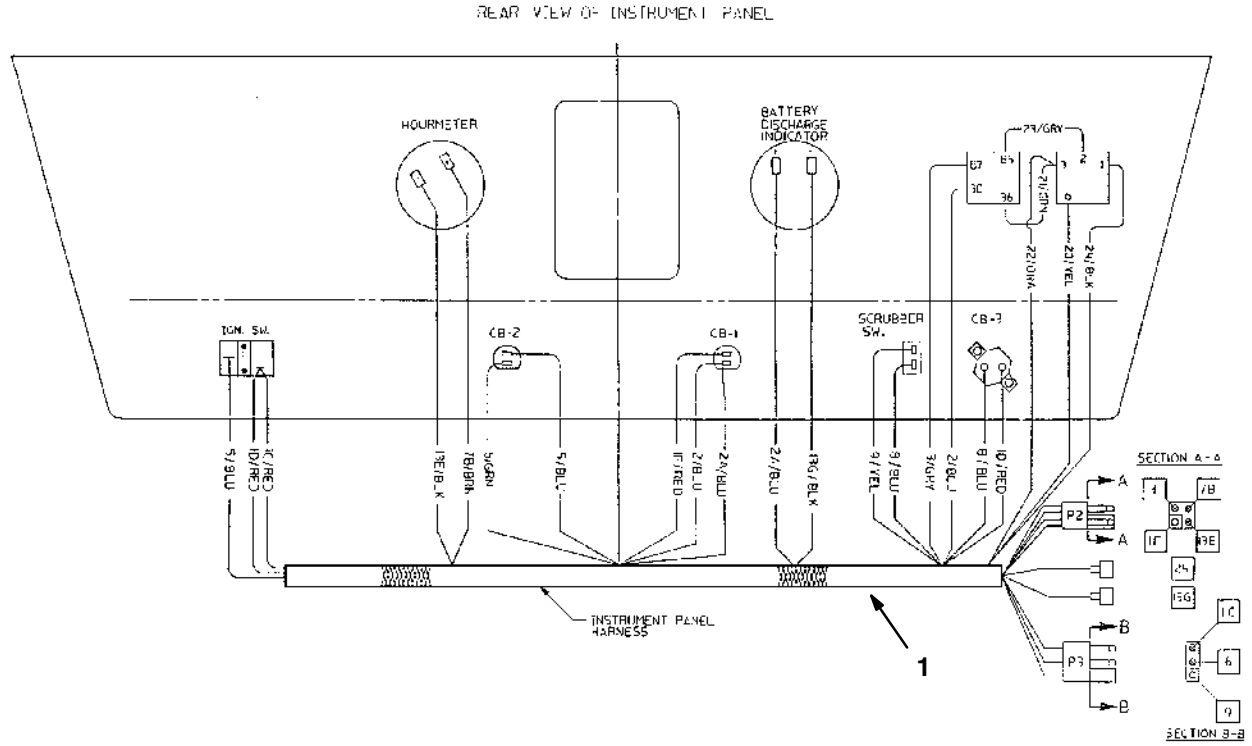
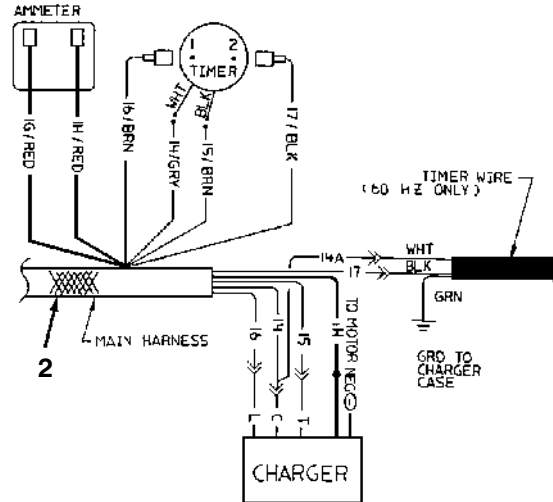

Fig. 16 – Wire Harnesses Group



"E" MACHINE
CHARGER WIRING

03096

Key	TENNANT Part No.	Machine Serial Number	Description	Qty.
1	01355	(000000-004368)	Wire Harness, Instrument Panel	1
1	09351	(004369-005999)	Wire Harness, Instrument Panel	1
2	01353	(000000-004368)	Wire Harness, Main	1
2	09350	(004369-005999)	Wire Harness, Main	1

Fig. 17 – Wire Harnesses Group

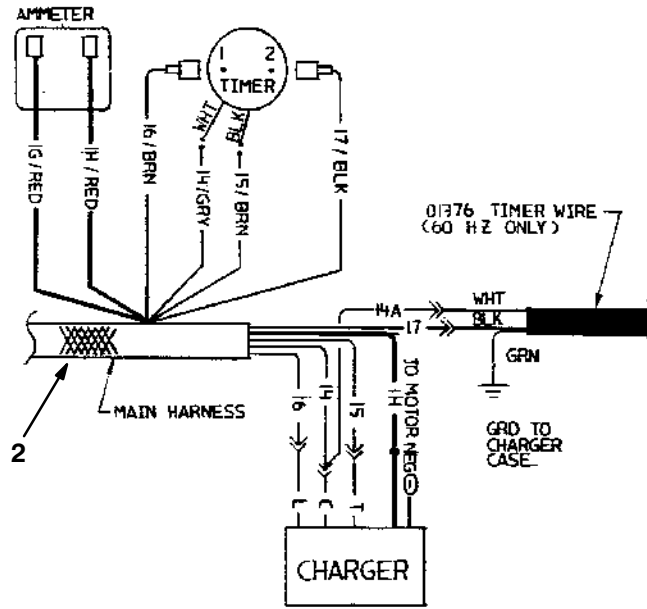

"E" MACHINE
CHARGER WIRING

Key	TENNANT Part No.	Machine Serial Number	Description	Qty.
1	50803	(006000-006822)	Wire Harness, Insrument Panel	1
2	50802	(006000-006822)	Wire Harness, Main	1

06436

Fig. 18 – Wire Harnesses Group

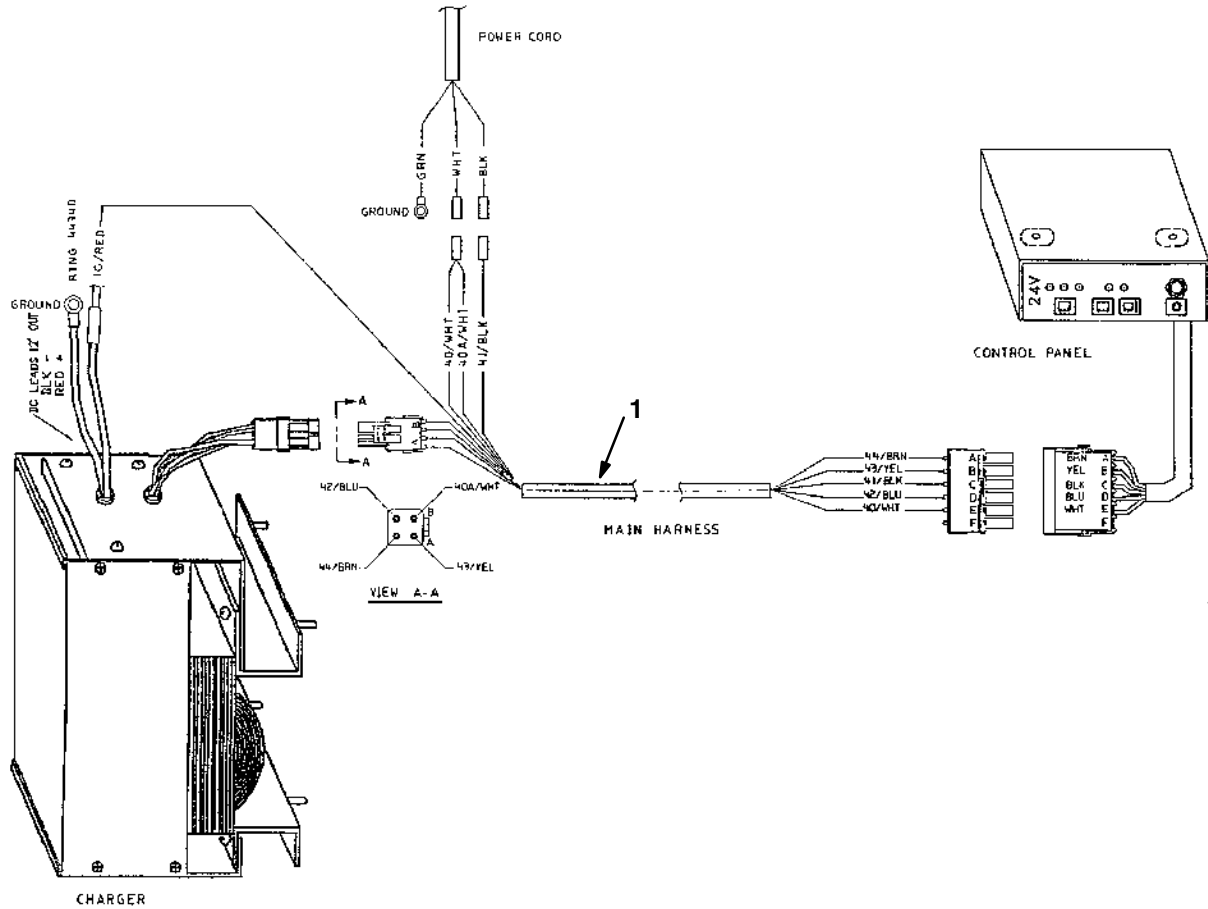

06389

Key	TENNANT Part No.	Machine Serial Number	Description	Qty.
1	60488	(006823–)	Wire Harness, Main	1
2	61671	(006823–)	Wire Harness, Instrument Panel	1

SECTION 7

CONTENTS

	Page
Fig. 1 – Electrical Components Group, EE	7-2
Fig. 2 – Electrical Components Group, EE	7-4
Fig. 3 – Wire Harnesses Group, EE	7-6
Fig. 4 – Wire Harnesses Group, EE	7-8
Fig. 5 – Wire Harnesses Group, EE	7-10
Fig. 6 – Cover Retainer Group, EE	7-12

Fig. 1 – Electrical Components Group, EE

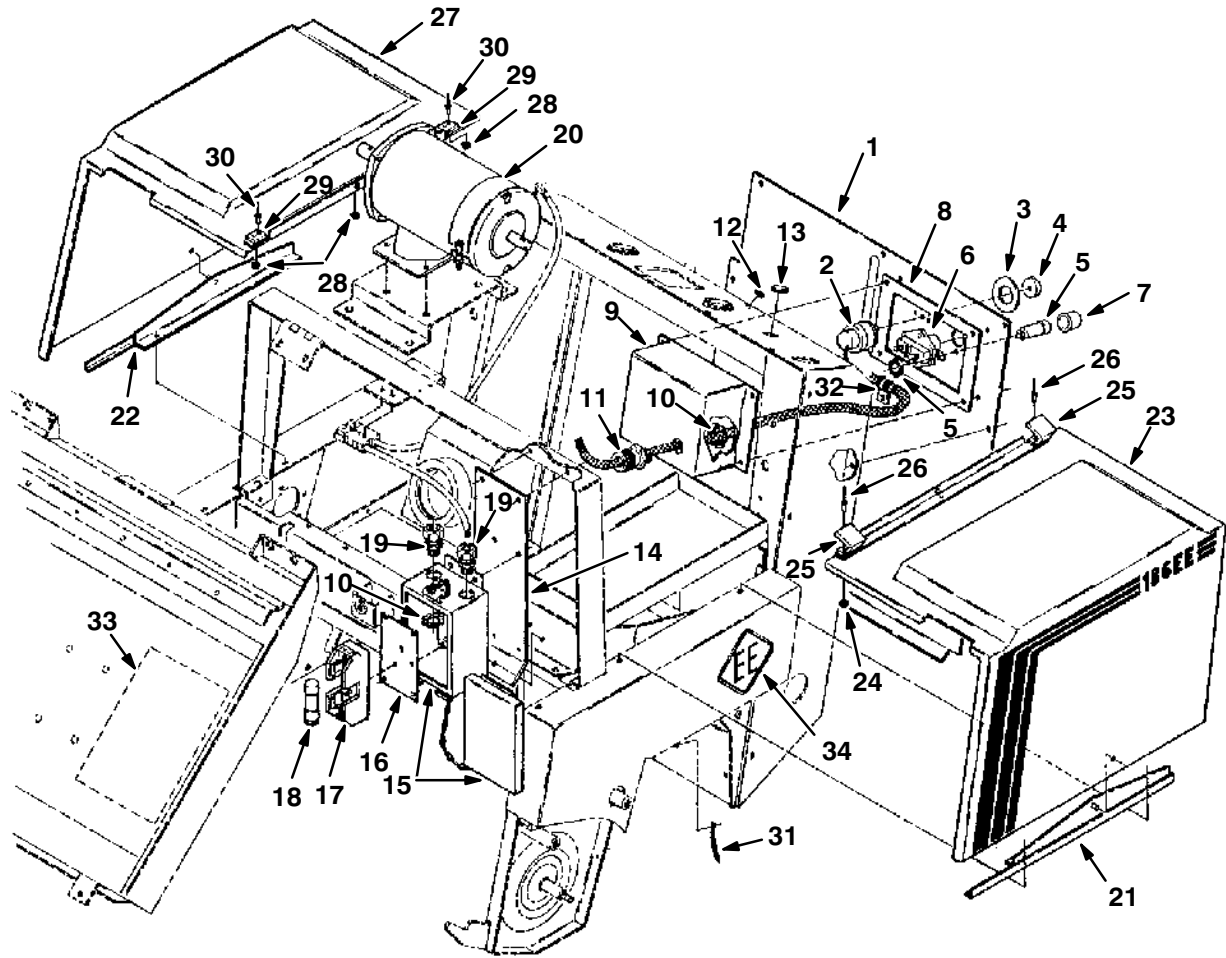

Fig. 1 – Electrical Components Group, EE

Key	TENNANT Part No.	Machine Serial Number	Description	Qty.
1	01489	(000000–005999)	Cover, Back	1
2	61104	(000000–005999)	Switch, Timer	1
3	09796	(000000–005999)	Decal, Timer	1
4	61106	(000000–005999)	Knob, Timer Pointer	1
5	57803	(000000–005999)	Breaker, Circuit	1
6	44078	(000000–005999)	Switch, Push	1
7	57751	(000000–005999)	Boot, Circuit Breaker	1
8	01491	(000000–005999)	Gasket	1
9	01490	(000000–005999)	Box, Instrument	1
10	10125	(000000–005999)	Nut, Lock	3
11	23072–1	(000000–005999)	Strain Relief	1
12	02431	(000000–005999)	Plugbutton	1
13	01493	(000000–004368)	Plug, Plastic	1
14	01551	(000000–005999)	Bracket, Fuse Box Mounting	1
15	39224	(000000–005999)	Box, Fuse	1
16	39215	(000000–005999)	Plate	1
17	32922	(000000–005999)	Holder, Fuse	1
18	04930	(000000–005999)	Fuse, 60 A	1
19	23072	(000000–005999)	Strain Relief	2
▽ 20	01191	(000000–005999)	Motor, Electric	1
▲	01739	(000000–005999)	Brush Kit	1
▲	01740	(000000–005999)	Springs, Brush	4
21	01538	(000000–005999)	Retainer, Cover, L.H.	1
22	01544	(000000–005999)	Retainer, Cover, R.H.	1
▽ 23	06462	(000000–005999)	Cover Assembly, L.H.	1
▲ 24	64757	(000000–005999)	Bumper, Rubber	3
▲ 25	01144	(000000–005999)	Closure, Edge Mating	2
▲ 26	01335	(000000–005999)	Rivet, Soft	4
▽ 27	06461	(000000–005999)	Cover Assembly, R.H.	1
▲ 28	64757	(000000–005999)	Bumper, Rubber	3
▲ 29	01144	(000000–005999)	Closure, Edge Mating	2
▲ 30	01335	(000000–005999)	Rivet, Soft	4
31	29704	(000000–005999)	Chain, Jack	1
32	26395	(000000–005999)	Clamp, Cable	1
33	01395	(000000–005999)	Label, Schematic	1
34	08823	(000000–005999)	Label, EE	2

Fig. 2 – Electrical Components Group, EE

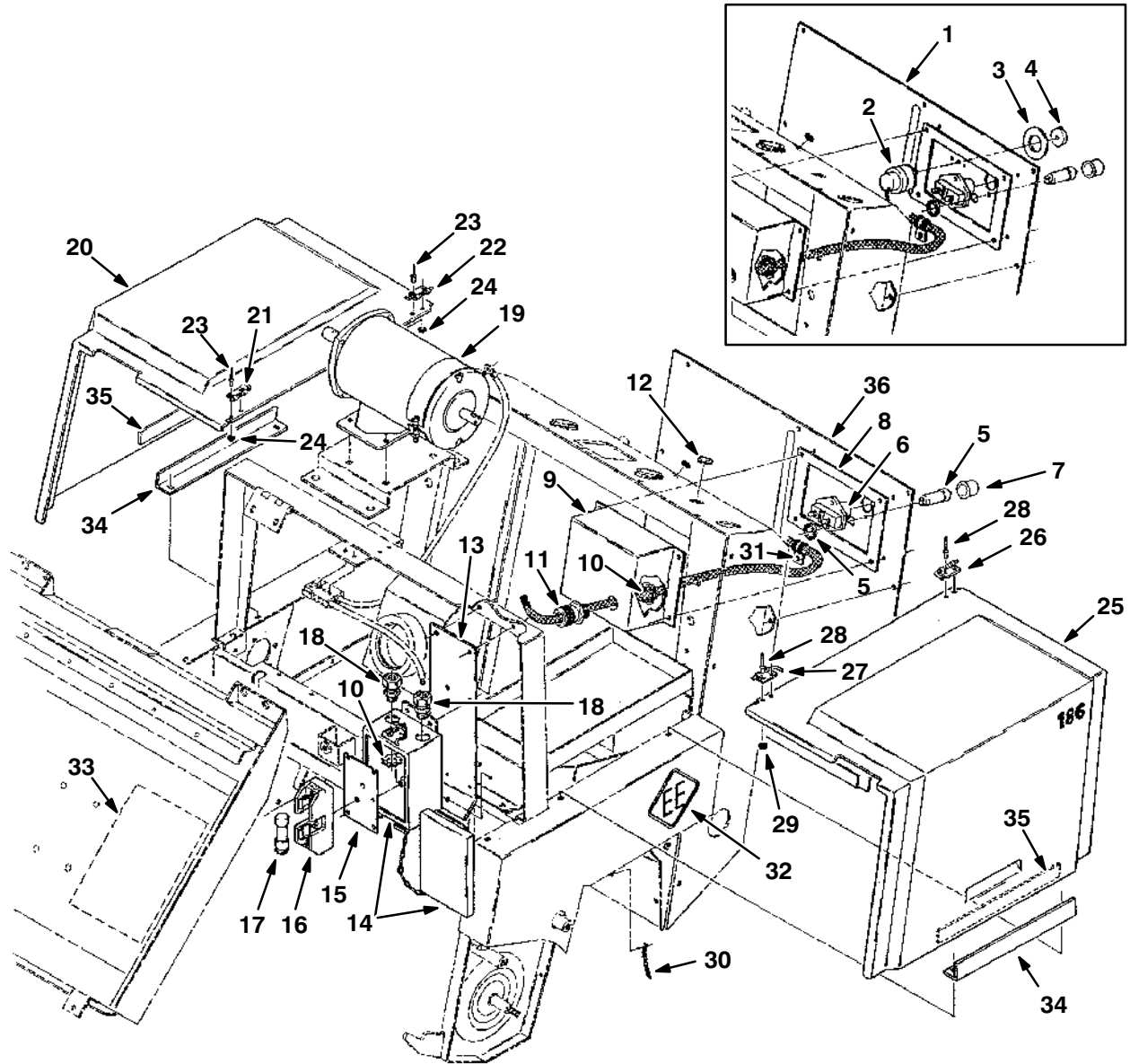
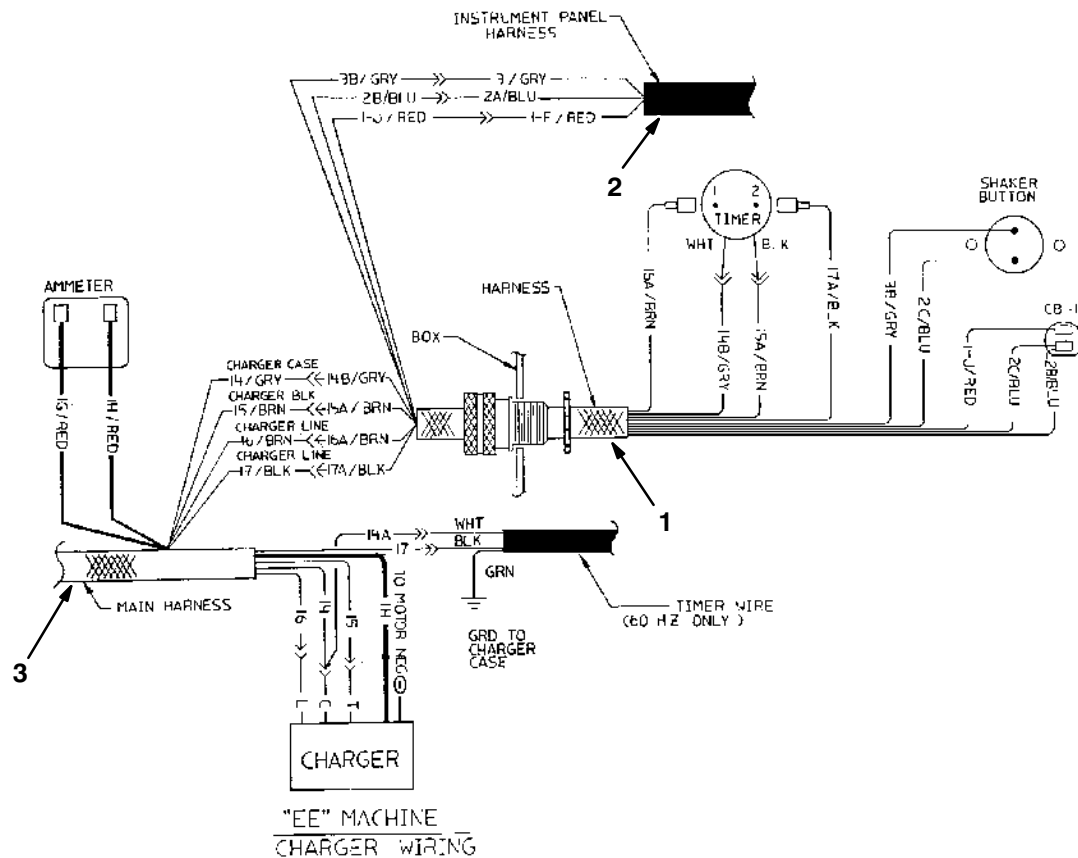

Fig. 2 – Electrical Components Group, EE

Key	TENNANT Part No.	Machine Serial Number	Description	Qty.
1	60594	(006000–006822)	Replacement Kit, Back Cover, F/50746	1
2	61104	(006000–006822)	Switch, Timer	1
3	41609	(006000–006822)	Decal, Timer	1
4	61106	(006000–006822)	Knob, Timer Pointer	1
5	57803	(006000–)	Breaker, Circuit	1
6	44078	(006000–)	Switch, Push	1
7	57751	(006000–)	Boot, Circuit Breaker	1
8	01491	(006000–)	Gasket	1
9	01490	(006000–)	Box, Instrument	1
10	10125	(006000–)	Nut, Lock	3
11	23072–1	(006000–)	Strain Relief	1
12	02431	(006000–)	Plugbutton	1
13	01551	(006000–)	Bracket, Fuse Box Mounting	1
14	39224	(006000–)	Box, Fuse	1
15	39215	(006000–)	Plate	1
16	32922	(006000–)	Holder, Fuse	1
17	04930	(006000–)	Fuse, 60 A	1
18	23072	(006000–)	Strain Relief	2
▽ 19	01191	(006000–)	Motor, Electric	1
▲	01739	(006000–)	Brush Kit	1
▲	01740	(006000–)	Springs, Brush	4
▽ 20	61062	(006000–)	Cover Assembly, R.H.	1
▲ 21	50832	(006000–)	Hinge, Pull Pin L.H.	1
▲ 22	50835	(006000–)	Hinge, Pull Pin R.H.	1
▲ 23	01335	(006000–)	Rivet, Soft	4
▲ 24	64757	(006000–)	Bumper, Rubber	3
▽ 25	61059	(006000–)	Cover Assembly, L.H.	1
▲ 26	50832	(006000–)	Hinge, Pull Pin L.H.	1
▲ 27	50835	(006000–)	Hinge, Pull Pin R.H.	1
▲ 28	01335	(006000–)	Rivet, Soft	4
▲ 29	64757	(006000–)	Bumper, Rubber	3
30	29704	(006000–)	Chain, Jack	1
31	26395	(006000–)	Clamp, Cable	1
32	08823	(006000–)	Label, EE	2
33	01641	(006000–)	Diagram, Electrical 186 EE	1
34	09494	(006000–)	Angle, Stop	2
35	09367	(006000–)	Magnetic Strip	2
36	60527	(006823–)	Cover, Back	1

Fig. 4 – Wire Harnesses Group, EE



Key	TENNANT Part No.	Machine Serial Number	Description	Qty.
1	01503	(006000-006822)	Wire Harness	1
	50470	(006000-006822)	Terminal, Female	5
	50474	(006000-006822)	Terminal, Male	7
2	50803	(006000-006822)	Wire Harness, Instrument Panel	1
3	50802	(006000-006822)	Wire Harness, Main	1

06387

Fig. 5 – Wire Harnesses Group, EE

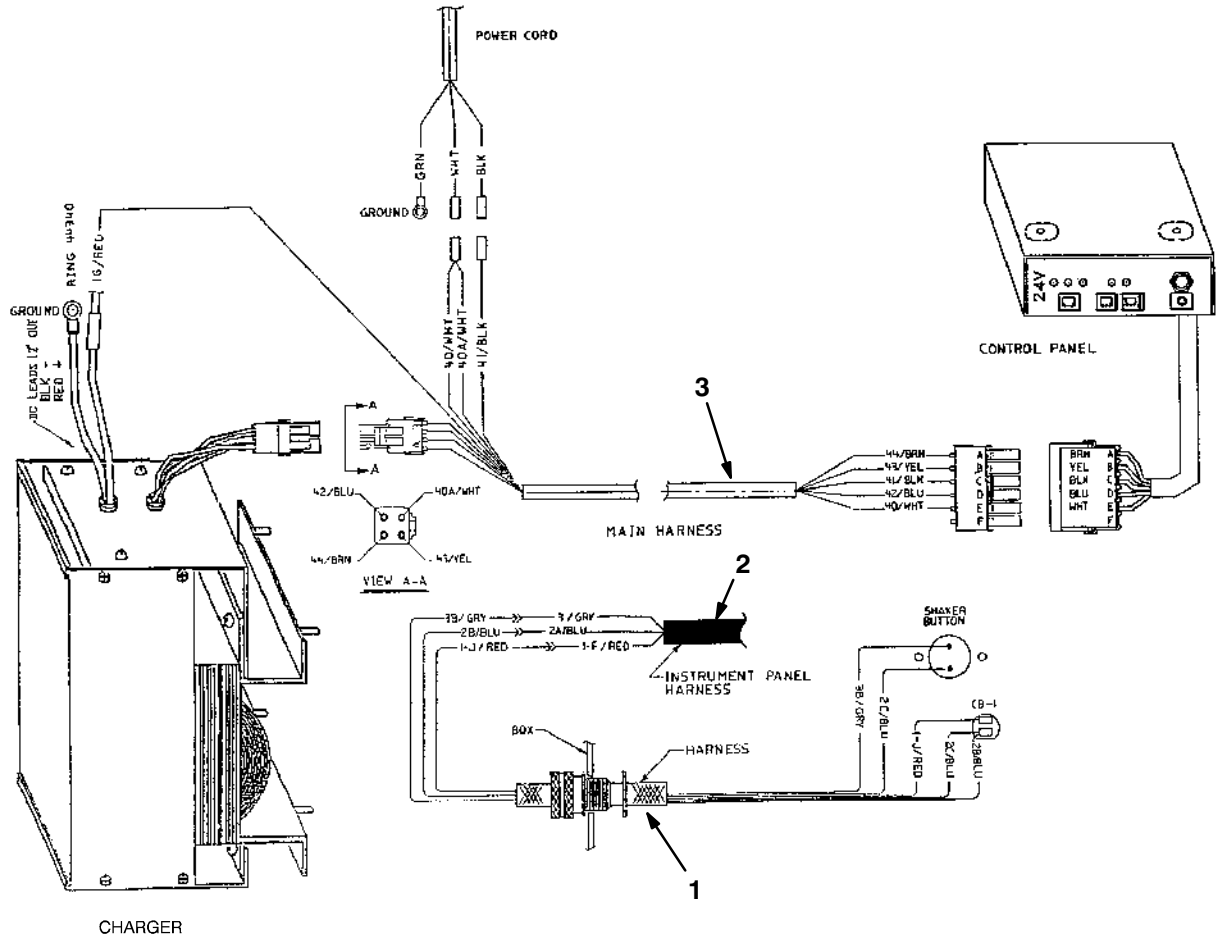

06907

Key	TENNANT Part No.	Machine Serial Number	Description	Qty.
1	60525	(006823-)	Wire Harness	1
2	61671	(006823-)	Wire Harness, Instrument Panel	1
3	60488	(006823-)	Wire Harness, Main	1

Fig. 6 – Cover Retainer Group, EE

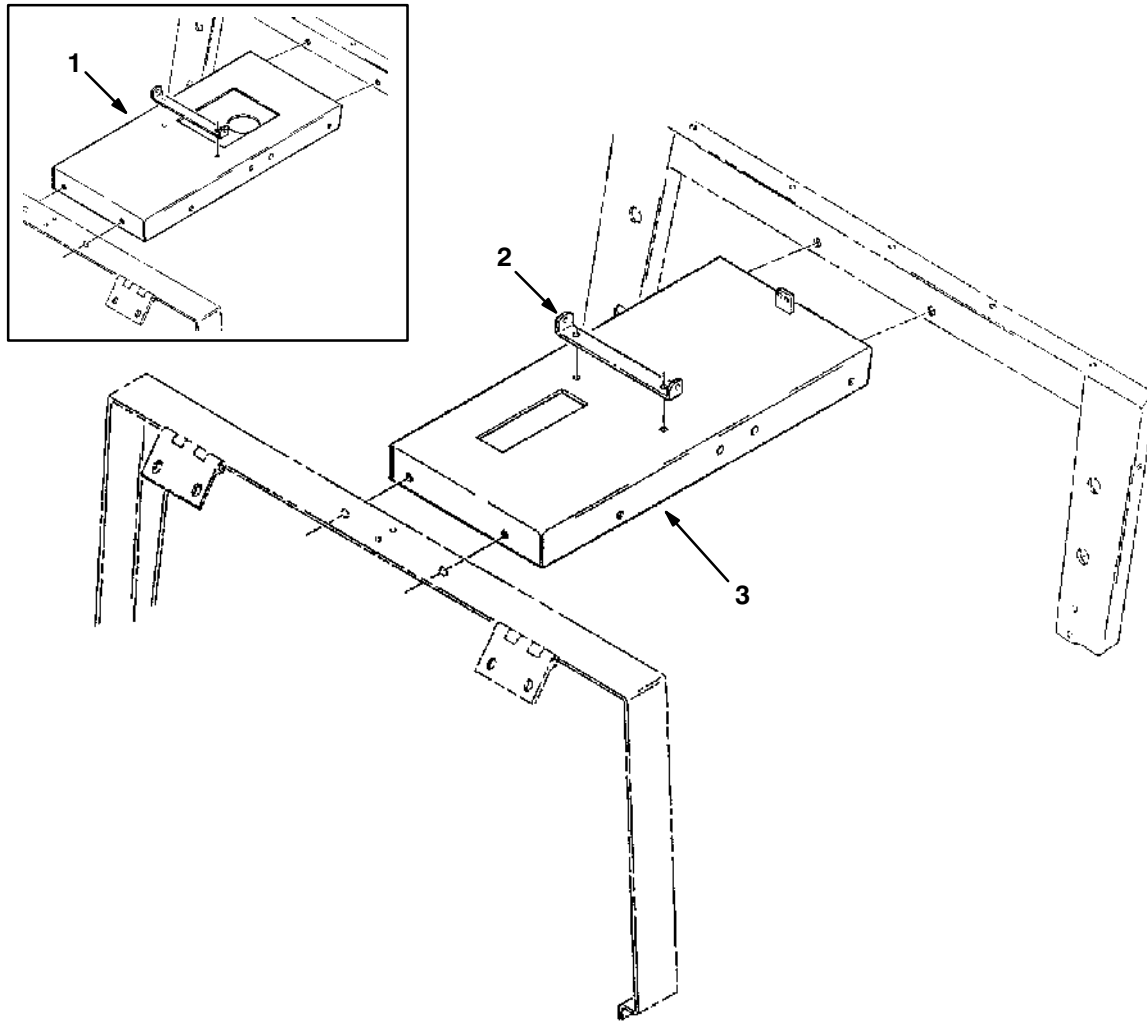

06384

Key	TENNANT Part No.	Machine Serial Number	Description	Qty.
1	61074	(006000–006822)	Channel, Center 186EE w/Label	1
2	61072	(006000–)	Retainer, cover	1
3	60526	(006823–)	Channel, Center 186EE w/Label	1

SECTION 8

CONTENTS

	Page
Fig. 1 – Solution Tank Group	8-2
Fig. 2 – Recovery Tank Group	8-4
Fig. 3 – Rear Squeegee Lift Group	8-6
Fig. 4 – Rear Squeegee Group	8-8
Fig. 5 – Side Scrub Brush Group	8-9
Fig. 6 – Scrub Vacuum Fan Group	8-10
Fig. 7 – Filter Bypass Kit	8-11
Fig. 8 – Recovery Tank Group, Water Pickup	8-12
Fig. 9 – Parking Brake Kit	8-14
Fig. 10 – Parking Brake Kit	8-15
Fig. 11 – Vacuum Wand Group	8-16
Fig. 12 – Wand Vacuum Fan Group	8-17
Fig. 13 – Vacuum Wand Group	8-18
Fig. 14 – Battery Kit, Wet	8-19
Fig. 15 – Battery Kit, Dry	8-20
Fig. 16 – Battery Charger and Timer Group	8-21
Fig. 17 – Battery Charger and Timer Group	8-22
Fig. 18 – Battery Charger and Timer Group	8-23
Fig. 19 – Battery Charger Group	8-24
Fig. 20 – Fire Extinguisher Kit	8-25
Fig. 21 – Battery Gauge Kit	8-26
Fig. 22 – Double Wheel Kit	8-27
Fig. 23 – Dual Caster Group	8-28
Fig. 24 – Plastic Hopper Kit	8-29
Fig. 25 – Fine Particle Filter Kit	8-30
Fig. 26 – Lift and Tie-Down Kit	8-31
Fig. 27 – Documentation Group	8-32

Fig. 1 – Solution Tank Group

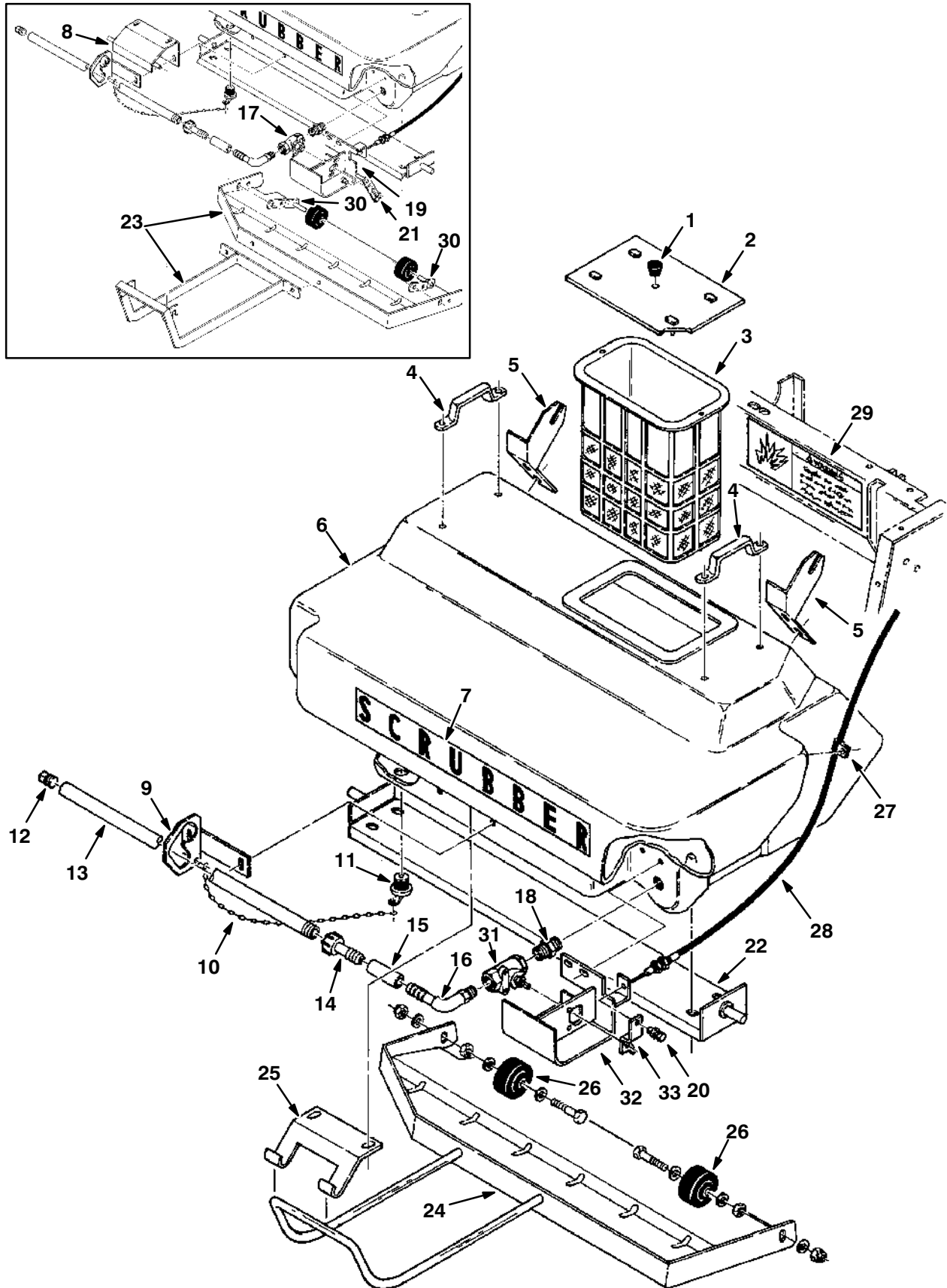

Fig. 1 – Solution Tank Group

NOTE: Scrubber Attachment Kit, TENNANT Part Number 01029, Includes Fig. 1, 2, 3, 4, 5, and 6.

Key	TENNANT Part No.	Machine Serial Number	Description	Qty.
1	28574	(000000–)	Knob	1
2	01504	(000000–)	Cover, Soap Basket	1
3	43516A	(000000–)	Basket, Soap	1
4	01576	(000000–)	Handle	2
5	01342	(000000–)	Hinge, Tank	2
6	01285	(000000–)	Tank, Solution	1
7	01568	(000000–)	Decal, Scrubber	1
8	01579	(000000–002470)	Support, Tray	1
9	01584	(000000–)	Guide, Tube	1
10	01570	(000000–)	Chain, Jack	1
11	01495	(000000–)	Plug, Expandable	1
12	01622	(000000–)	Fitting, Plug	1
13	01621	(000000–)	Tube, Spreader	1
14	01644	(000000–)	Fitting, Barbed Straight	1
15	01643	(000000–)	Hose, Vinyl	1
16	06478	(000000–)	Fitting, Barbed Elbow	1
17	12053	(000000–002802)	Valve Replacement Kit, Water	1
18	01642	(000000–)	Fitting, Nipple	1
19	01343	(000000–002802)	Bracket, Valve	1
20	43242	(000000–)	Swivel	1
21	06645	(000000–002802)	Arm Replacement Kit, Valve	1
22	06620	(000000–)	Carriage, Solution Tank	1
▽ 23	10387	(000000–)	Tray Assembly, Debris	1
▲ 24	10383	(002471–)	Pan, Debris	1
▲ 25	06654	(002471–)	Support, Tray	1
▲ 26	01580	(000000–)	Wheel, Rubber	2
27	46236	(000000–)	Clamp, Cable	1
▽ 28	01329	(000000–)	Cable, Water Control	1
▲	08067	(000000–)	Cable, Internal	1
29	06800	(000000–)	Decal, Warning, Detergent	1
30	06615	(000000–002470)	Replacement Kit, Axle	2
31	60595	(002803–)	Valve, Water	1
32	12078	(002803–)	Bracket, Valve	1
33	12081	(002803–)	Arm, Valve	1

Fig. 2 – Recovery Tank Group

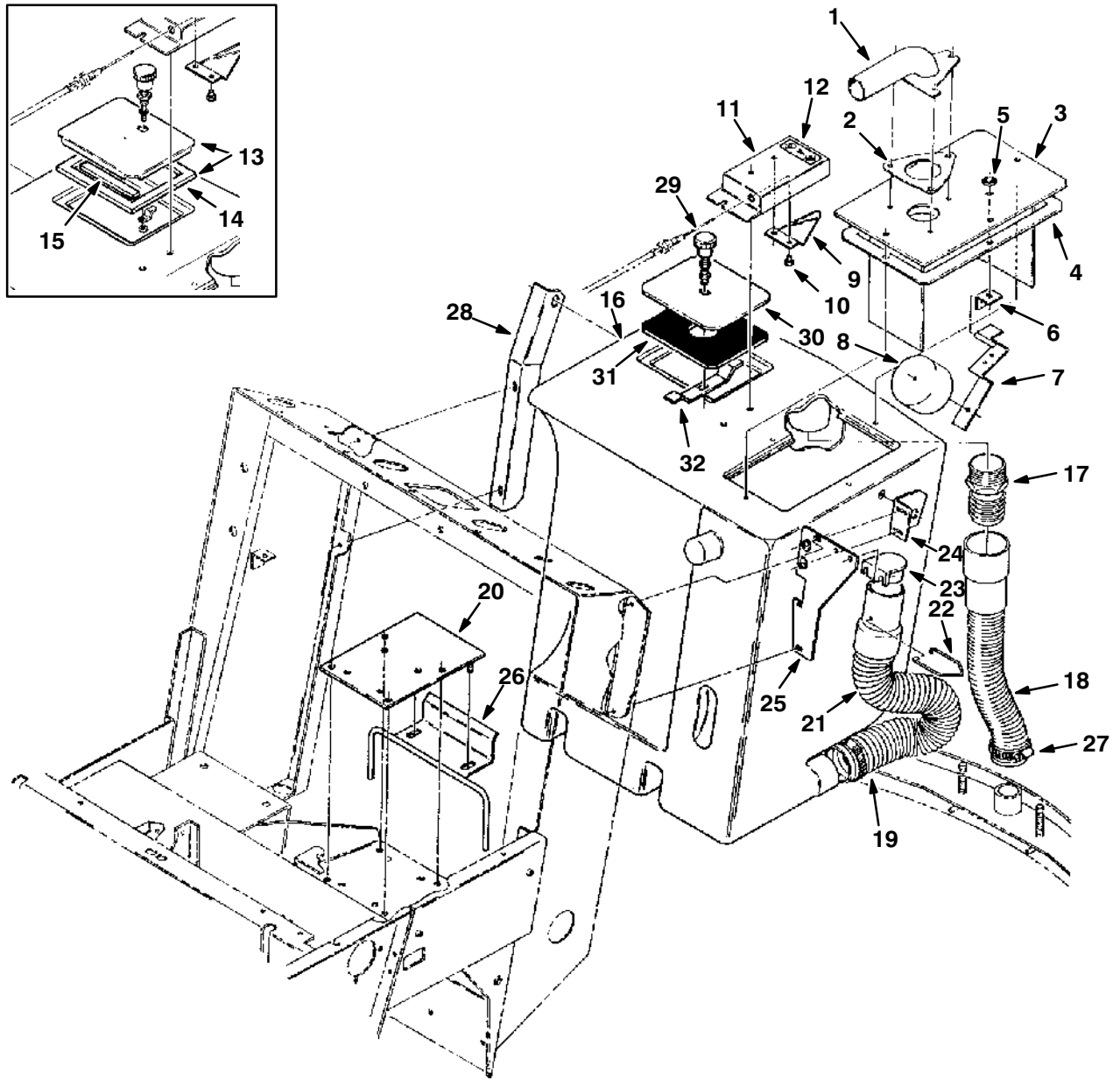

Fig. 2 – Recovery Tank Group

NOTE: Scrubber Attachment Kit, TENNANT Part Number 01029, Includes Fig. 1, 2, 3, 4, 5, and 6.

Key	TENNANT Part No.	Machine Serial Number	Description	Qty.
1	01520	(000000–)	Tube	1
2	29664	(000000–)	Gasket	1
3	01525	(000000–)	Plate, Float	1
4	01640	(000000–)	Gasket, Float Plate	1
5	76426	(000000–002670)	Washer, Sealing	2
5	76426	(002671–)	Washer, Sealing	1
6	63310	(000000–002670)	Bracket, L	2
6	63310	(002671–)	Bracket, L	1
7	45938–1	(000000–)	Bracket, Float Mounting	1
8	45937	(000000–)	Float, Vacuum Fan	1
9	01628	(000000–002802)	Lever, Water Control	1
9	12077	(002803–)	Lever, Water Control	1
10	43242	(000000–)	Swivel	1
11	01633	(000000–002802)	Mount, Valve Lever	1
11	12075	(002803–)	Mount, Valve Lever	1
12	06796	(000000–)	Decal, Solution Control	1
▽ 13	06762	(000000–002216)	Cover Assembly, Tank (Replaced by 10218)	1
▲ 14	28950–2	(000000–002216)	Seal, Foam Rubber	1
▲ 15	49351–3	(000000–002216)	Seal, Foam Rubber	1
16	01286	(000000–)	Tank, Recovery	1
17	01639	(000000–)	Fitting, Barbed Straight	1
18	01536	(000000–)	Hose, Squeegee	1
19	22297	(000000–)	Clamp, Worm Drive	1
20	01413	(000000–)	Support, Tank	1
21	30246	(000000–)	Hose, Drain	1
22	20267	(000000–)	Clip, Retainer	1
23	20215	(000000–)	Plug	1
24	01494	(000000–)	Bracket, Tie Down, L.H.	1
25	01499	(000000–)	Bracket, Pickup Handle	1
26	01534	(000000–)	Retainer	1
27	11531	(000000–)	Clamp, Worm Drive	1
28	01492	(000000–)	Bracket, Tie Down, R.H.	1
▽ 10218	10218	(002217–)	Cover and Seal Assembly, Recovery Tank	1
▲ 29	87337	(000000–)	Latch, Door	1
▲ 30	08091	(002217–)	Cover, Recovery Tank	1
▲ 31	08092	(002217–)	Gasket, Cover	1
▲ 32	08093	(002217–)	Pawl, Latch	1

Fig. 3 – Rear Squeegee Lift Group

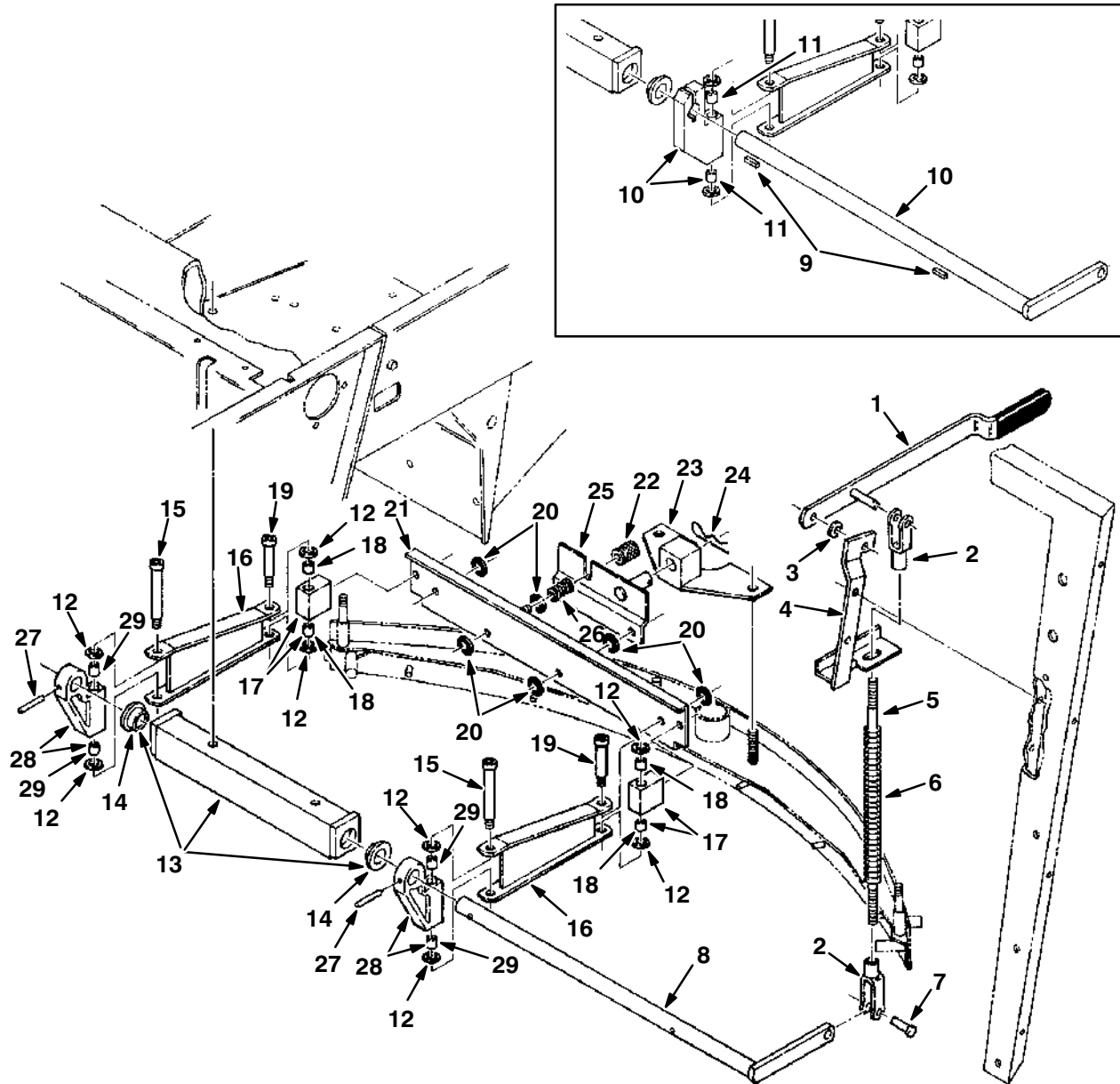
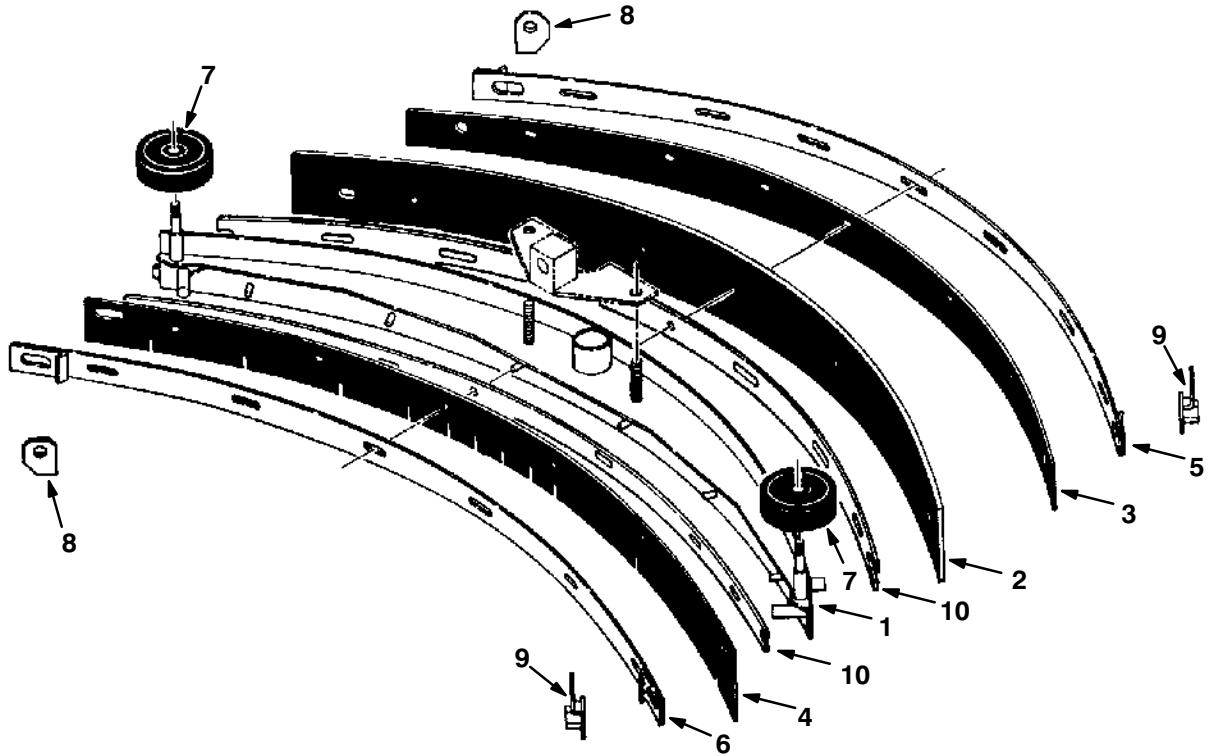

Fig. 3 – Rear Squeegee Lift Group

*NOTE: Scrubber Attachment Kit, TENNANT Part Number 01029, Includes Fig. 1, 2, 3, 4, 5, and 6.
Water Pickup Kit, TENNANT Part Number 08071, Includes Fig. 3, 4, 6, 7, and 8.*

Key	TENNANT Part No.	Machine Serial Number	Description	Qty.
1	01559	(000000–)	Handle, Squeegee Lift	1
2	14330	(000000–)	Yoke, Adjustable	2
3	43454	(000000–)	Washer, Nylon	1
4	01498	(000000–)	Bracket, Pivot	1
5	01344	(000000–)	Rod, Squeegee Lift	1
6	75774	(000000–)	Spring, Compression	1
7	14331	(000000–)	Pin, Clevis	1
8	10361	(002686–)	Shaft, Squeegee Lift	1
9	00911	(000000–002685)	Key, Square	2
▽ 10	06619	(000000–002685)	Squeegee Hinge Replacement Kit	1
▲ 11	01511	(000000–002685)	Bearing, Sleeve	2
12	43611	(000000–)	Washer, Nylon	8
▽ 13	01517	(000000–)	Bar Assembly, Pivot	1
▲ 14	01334	(000000–)	Bearing, Flange	2
15	01507	(000000–)	Screw, Shoulder	2
16	01532	(000000–)	Link, Squeegee	2
▽ 17	01510	(000000–)	Block Assembly, Hinge	2
▲ 18	01511	(000000–)	Bearing, Sleeve	2
19	01508	(000000–)	Screw, Shoulder	2
20	45089	(000000–)	Washer, Rubber	6
21	01347	(000000–)	Rail, Squeegee	1
22	45086	(000000–)	Knob, Adjustment	1
23	01555	(000000–)	Mount, Squeegee	1
24	44906	(000000–)	Pin, Hair Cotter	1
25	01345	(000000–)	Plate, Pivot	1
26	57889	(000000–)	Spring, Compression	1
27	26239	(002686–)	Pin, Roll	2
▽ 28	10386	(002686–)	Hinge Assembly, Arm	2
▲ 29	01511	(002686–)	Bearing, Sleeve	2

Fig. 4 – Rear Squeegee Group



03105

*NOTE: Scrubber Attachment Kit, TENNANT Part Number 01029, Includes Fig. 1, 2, 3, 4, 5, and 6.
Water Pickup Kit, TENNANT Part Number 08071, Includes Fig. 3, 4, 6, 7, and 8.*

Key	TENNANT Part No.	Machine Serial Number	Description	Qty.
▽	01636	(000000–)	Squeegee Assembly	1
▲ 1	01502	(000000–)	Frame, Squeegee	1
▲▽	01780	(000000–)	Performance Package, Squeegee	1
▲▲ 2	03856	(000000–)	Blade, Squeegee	1
▲▲ 3	01657	(000000–)	Strip, Rear Backup	1
▲▲ 4	63967	(000000–)	Blade, Squeegee	1
▲ 5	63034	(000000–)	Band, Rear	1
▲ 6	63038	(000000–)	Band, Front	1
▲ 7	29653	(000000–)	Wheel, Solid	2
▲ 8	63327	(000000–)	Cam	2
▲ 9	63329	(000000–)	Cam	2
▲ 10	06481	(000000–)	Strip, Abrasive	2

Fig. 5 – Side Scrub Brush Group

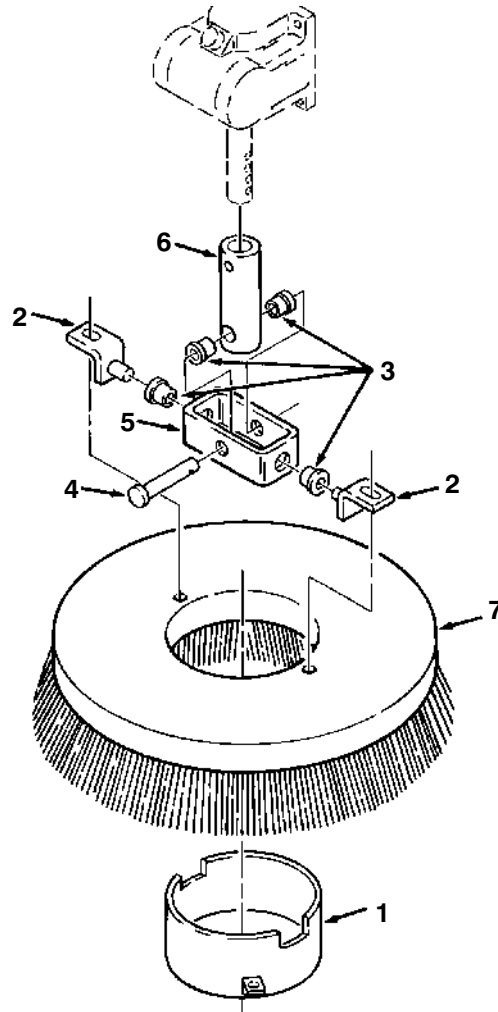

03103

NOTE: Scrubber Attachment Kit, TENNANT Part Number 01029, Includes Fig. 1, 2, 3, 4, 5, and 6.

Key	TENNANT Part No.	Machine Serial Number	Description	Qty.
1	29592	(000000–)	Ring	1
2	31039	(000000–)	Pivot	2
3	29585	(000000–)	Bushing, Flange	4
4	17461	(000000–)	Pin, Clevis	1
5	31037	(000000–)	Tube, Swivel Box	1
6	29586	(000000–)	Tube, Hub	1
7	29406	(000000–)	Side Brush, Scrubbing, Polypropylene	1

Fig. 6 – Scrub Vacuum Fan Group

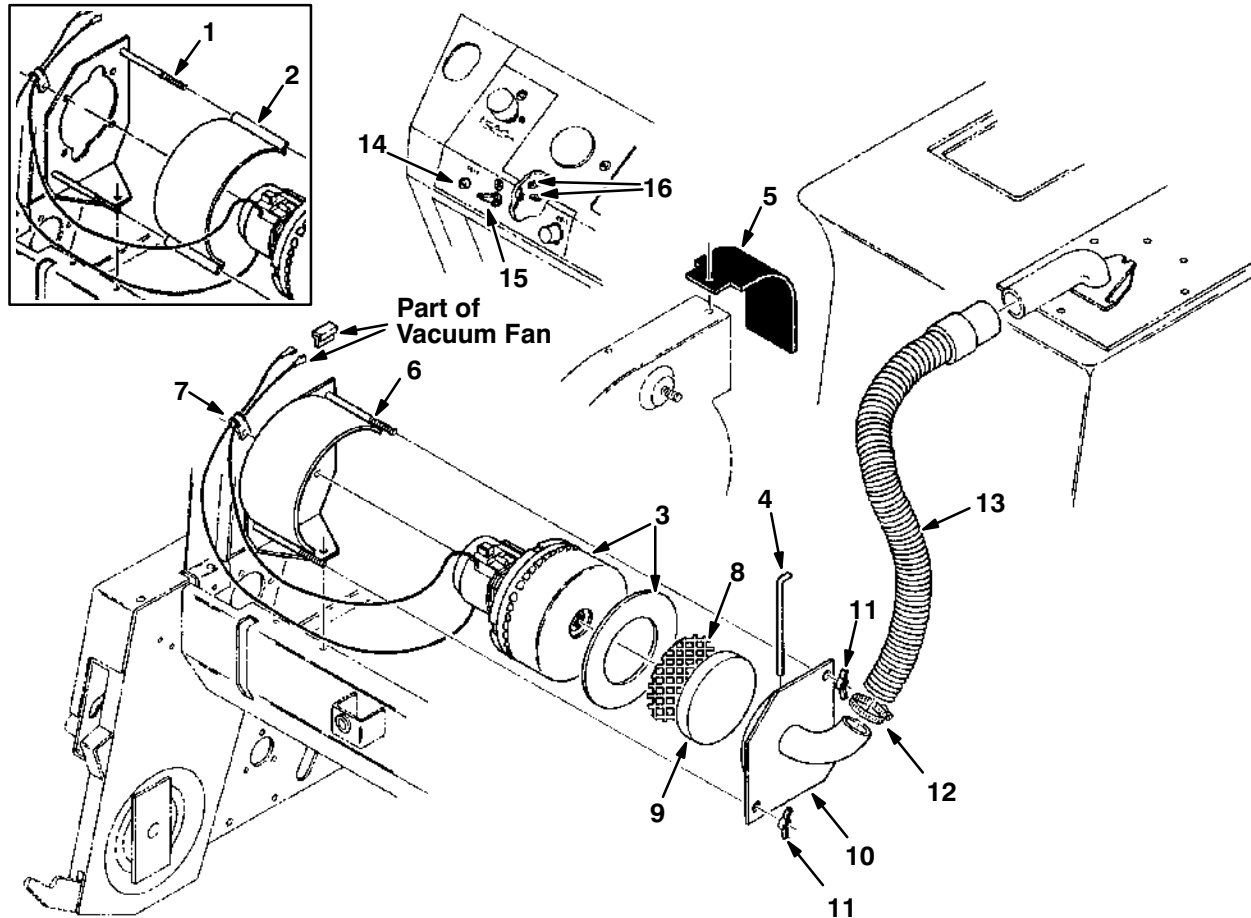

03104

*NOTE: Scrubber Attachment Kit, TENNANT Part Number 01029, Includes Fig. 1, 2, 3, 4, 5, and 6.
Water Pickup Kit, TENNANT Part Number 08071, Includes Fig. 3, 4, 6, 7, and 8.*

Key	TENNANT Part No.	Machine Serial Number	Description	Qty.
1	01466	(000000-002638)	Mount, Vacuum Fan (Replaced by 06655)	1
2	01467	(000000-002638)	Shield, Vacuum Fan (Replaced by 06655)	1
3	01475	(000000-)	Fan Assembly, Vacuum	1
4	01635	(000000-)	Rod, Retainer	1
5	01261	(000000-)	Deflector	1
6	06655	(002639-)	Mount, Vacuum Fan	1
7	26395-2	(000000-)	Clamp, Cable	1
8	63143	(000000-)	Screen	1
9	63144	(000000-)	Filter, Vacuum Fan	1
10	06657	(000000-)	Cover, Vacuum Fan	1
11	39272	(000000-)	Nut, Wing	2
12	11531	(000000-)	Clamp, Worm Drive	1
13	29693	(000000-)	Hose and Cuff Assembly	1
14	63030	(000000-)	Breaker, Circuit	1
15	70320	(000000-)	Switch	1
16	68106	(000000-)	Tab, Terminal	2

Fig. 7 – Filter Bypass Kit

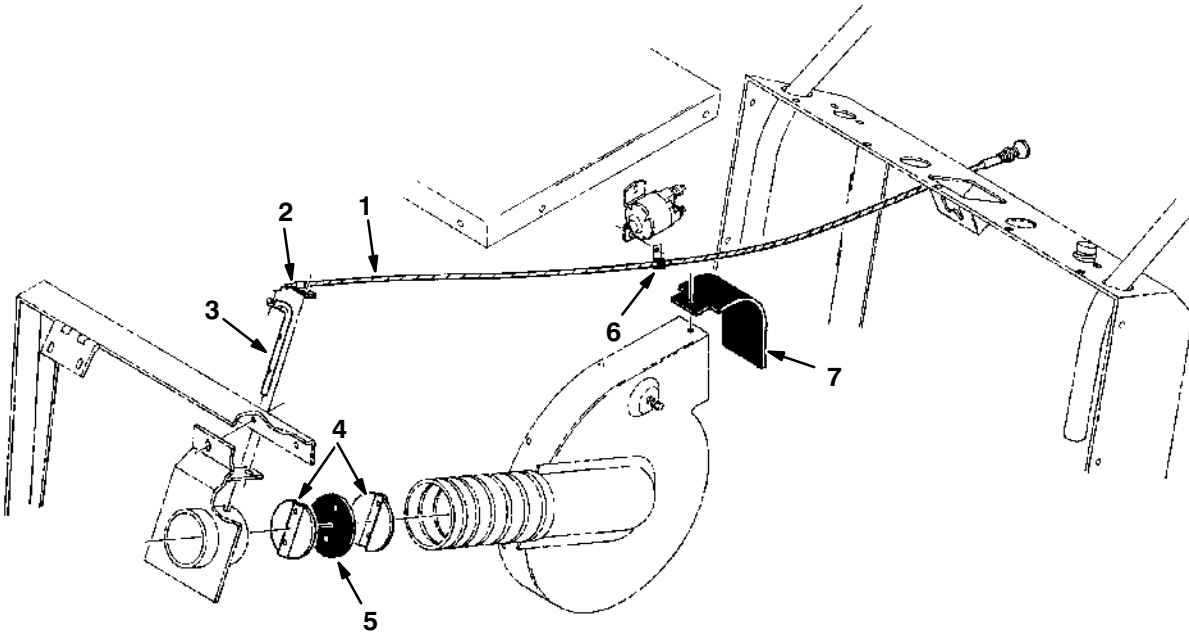

03538

NOTE: Water Pickup Kit, TENNANT Part Number 08071, Includes Fig. 3, 4, 6, 7, and 8.

Key	TENNANT Part No.	Machine Serial Number	Description	Qty.
▽	08076	(000000–)	Filter Bypass Kit	1
▲ 1	08078	(000000–)	Cable, Control	1
▲ 2	26414	(000000–)	Clamp, Cable	1
▲ 3	41294	(000000–)	Lever, Damper	1
▲ 4	46140	(000000–)	Plate, Damper	2
▲ 5	46139	(000000–)	Seal	1
▲ 6	46236	(000000–)	Clamp, Cable	1
▲	49266	(000000–)	Tie, Cable	1
7	01261	(000000–)	Deflector	1

Fig. 8 – Recovery Tank Group, Water Pickup

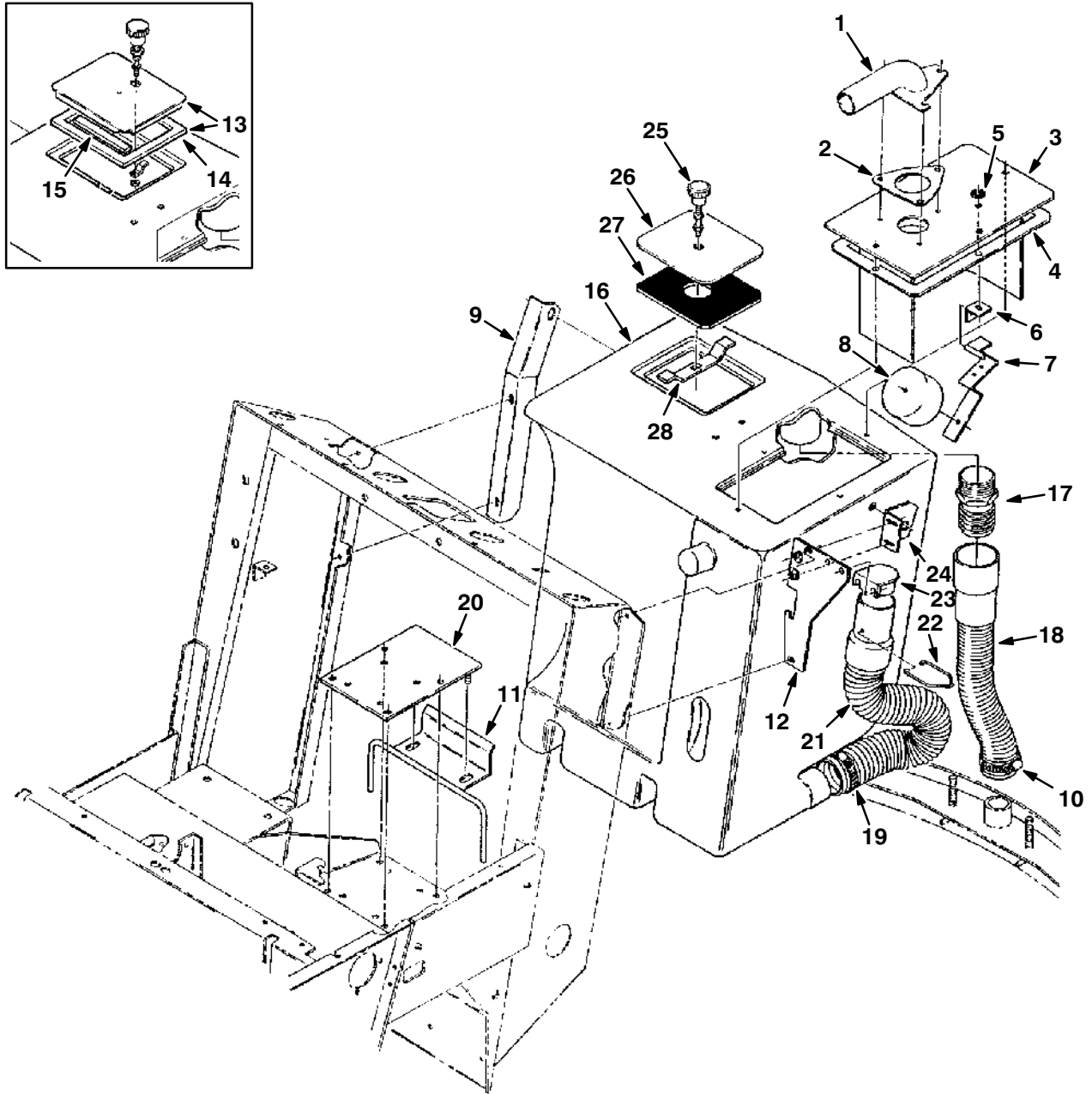
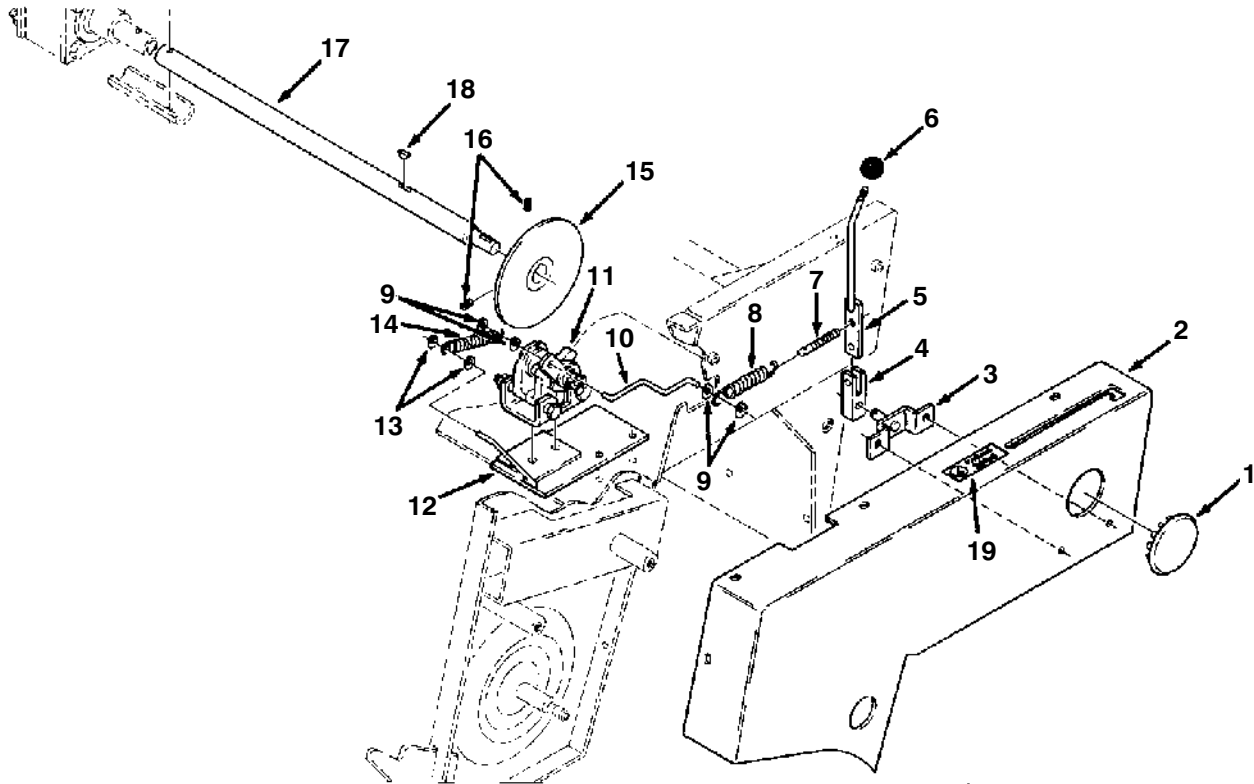

Fig. 8 – Recovery Tank Group, Water Pickup

NOTE: Water Pickup Kit, TENNANT Part Number 08071, Includes Fig. 3, 4, 6, 7, and 8.

Key	TENNANT Part No.	Machine Serial Number	Description	Qty.
1	01520	(000000–)	Tube	1
2	29664	(000000–)	Gasket	1
3	01525	(000000–)	Plate, Float	1
4	01640	(000000–)	Gasket, Float Plate	1
5	76426	(000000–002670)	Washer, Sealing	2
5	76426	(002671–)	Washer, Sealing	1
6	63310	(000000–002670)	Bracket, L	2
6	63310	(002671–)	Bracket, L	1
7	45938–1	(000000–)	Bracket, Float Mounting	1
8	45937	(000000–)	Float, Vacuum Fan	1
9	01492	(000000–)	Bracket, Tie Down, R.H.	1
10	11531	(000000–)	Clamp, Worm Drive	1
11	01534	(000000–)	Retainer	1
12	01499	(000000–)	Bracket, Pickup Handle	1
▽ 13	06762	(000000–002216)	Cover Assembly, Tank (Replaced by 10218)	1
▲ 14	28950–2	(000000–002216)	Seal, Foam Rubber	1
▲ 15	49351–3	(000000–002216)	Seal, Foam Rubber	1
16	01286	(000000–)	Tank, Recovery	1
17	01639	(000000–)	Fitting, Barbed, Straight	1
18	01536	(000000–)	Hose, Squeegee	1
19	22297	(000000–)	Clamp, Worm Drive	1
20	01413	(000000–)	Support, Tank	1
21	30246	(000000–)	Hose, Drain	1
22	20267	(000000–)	Clip, Retainer	1
23	20215	(000000–)	Plug	1
24	01494	(000000–)	Bracket, Tie Down, L.H.	1
▽	10218	(002217–)	Cover and Seal Assembly, Recovery Tank	1
▲ 25	87337	(000000–)	Latch, Door	1
▲ 26	08091	(002217–)	Cover, Recovery Tank	1
▲ 27	08092	(002217–)	Gasket, Cover	1
▲ 28	08093	(002217–)	Pawl, Latch	1

Fig. 9 – Parking Brake Kit



03052

Key	TENNANT Part No.	Machine Serial Number	Description	Qty.
▽	01444	(000000–002315)	Brake Kit, Parking (Replaced by 10368)	1
▲ 1	82747	(000000–002315)	Plugbutton	1
▲ 2	01469	(000000–002315)	Cover, L.H.	1
▲ 3	01473	(000000–002315)	Bracket, Parking Brake	1
▲ 4	01476	(000000–002315)	Pivot, Parking Brake	1
▲ 5	01479	(000000–002315)	Handle, Parking Brake	1
▲ 6	01506	(000000–002315)	Knob	1
▲ 7	01554	(000000–002315)	Screw, Adjustment	1
▲ 8	28281	(000000–002315)	Spring, Tension	1
▲ 9	39021	(000000–002315)	Ring, Retaining	4
▲ 10	01471	(000000–002315)	Link, Brake	1
▲ 11	01470	(000000–002315)	Brake	1
▲ 12	01438	(000000–002315)	Plate, Adaptor	1
▲ 13	23524–3	(000000–002315)	Ring, Retaining	2
▲ 14	01053	(000000–002315)	Spring, Tension	1
▲ 15	35927	(000000–002315)	Disc, Brake	1
▲ 16	57496	(000000–002315)	Screw, Nylon Set	2
▲ 17	01439	(000000–002315)	Countershaft	1
▲ 18	00500–10	(000000–002315)	Key, Woodruff	1
▲ 19	63785	(000000–002315)	Decal, Parking Brake	1

Fig. 10 – Parking Brake Kit

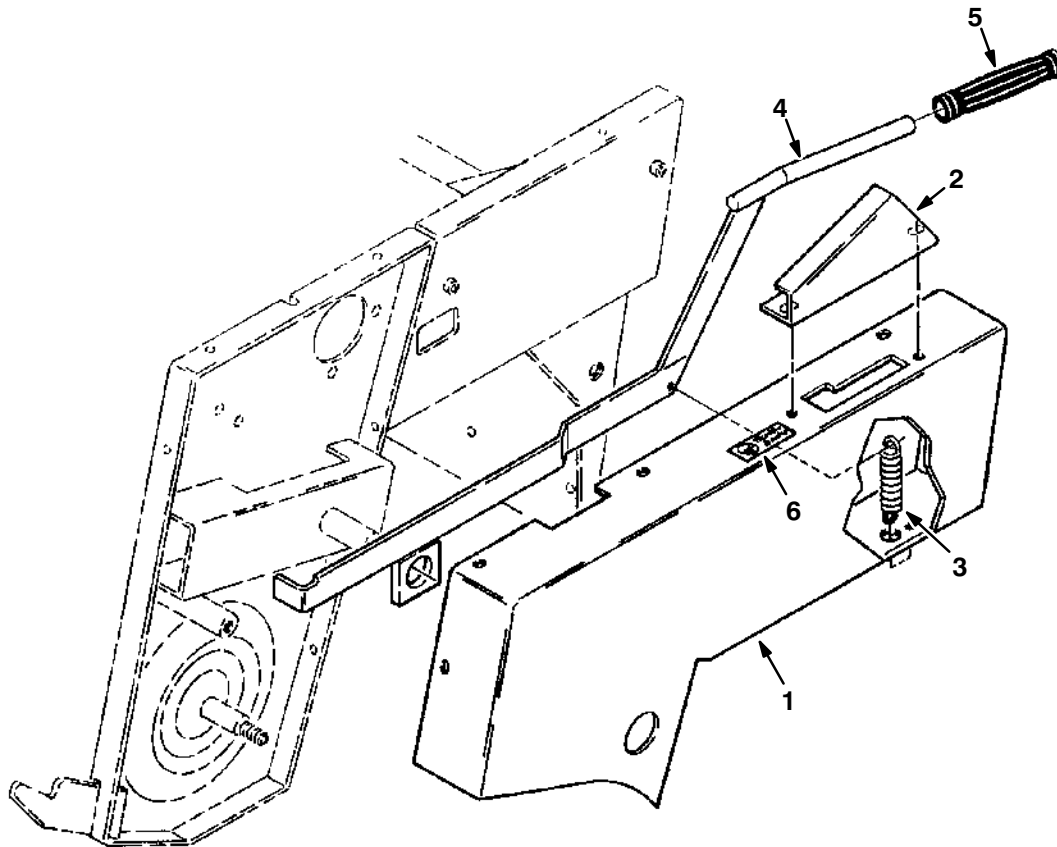

04315

Key	TENNANT Part No.	Machine Serial Number	Description	Qty.
▽	10368	(002316-005999)	Brake Kit, Parking	1
▲ 1	10372	(002316-005999)	Cover, Left Side	1
▲ 2	10379	(002316-005999)	Latch, Brake	1
▲ 3	29545	(002316-005999)	Spring, Tension	1
▲ 4	10378	(002316-005999)	Brake, Parking	1
▲ 5	10381	(002316-005999)	Grip, Handle	1
▲ 6	63785	(002316-005999)	Label, Parking Brake	1

Fig. 11 – Vacuum Wand Group

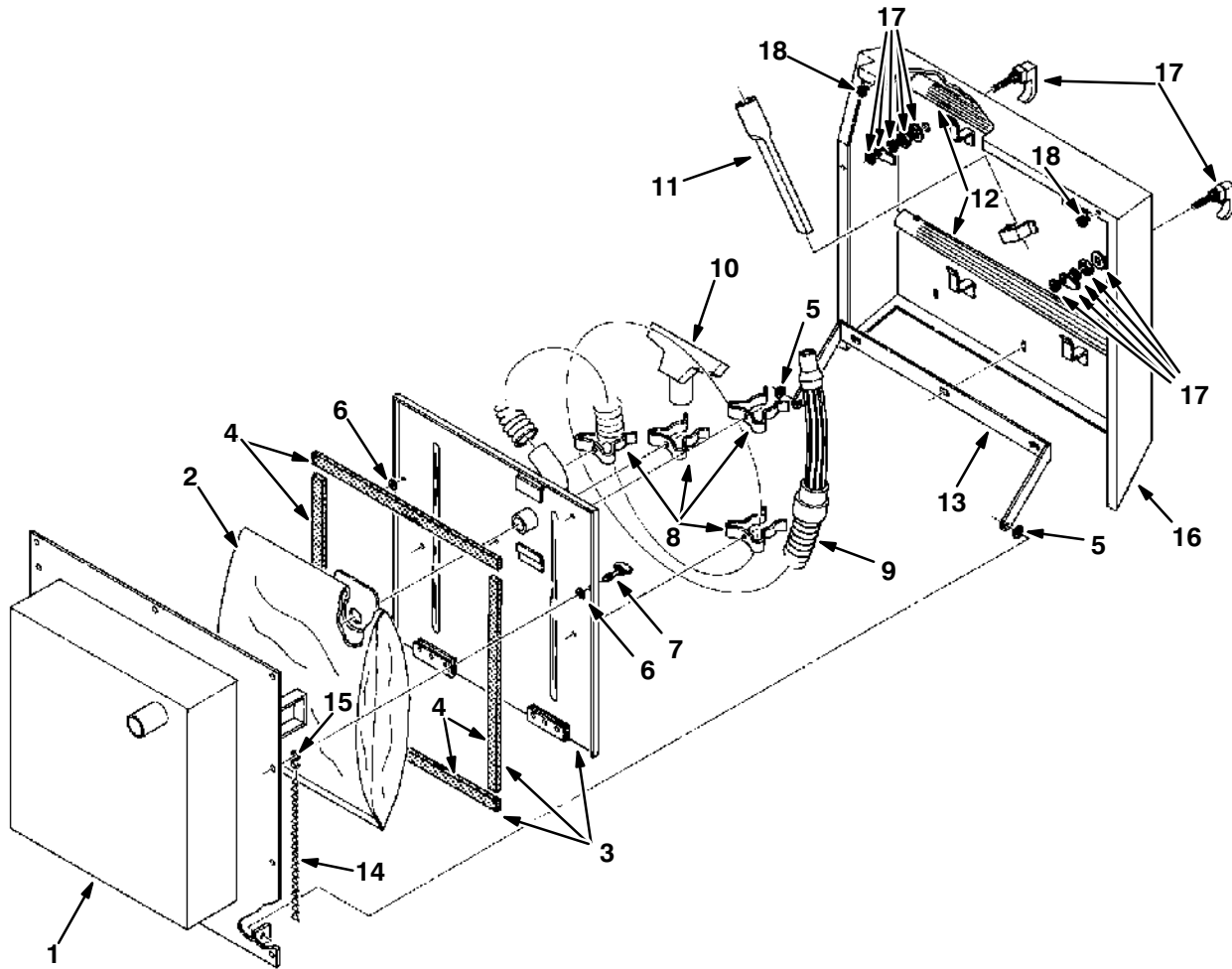

03115

NOTE: Vacuum Wand Kit, TENNANT Part Number 01031, Includes Fig. 11 and 12.

Key	TENNANT Part No.	Machine Serial Number	Description	Qty.
1	01398	(000000–005999)	Frame, Mounting and Vacuum Box	1
2	06482	(000000–005999)	Bags, Vacuum Wand (Set of 10)	1
▽ 3	06741	(000000–005999)	Door Assembly, Vacuum Box	1
▲ 4	01392	(000000–005999)	Seal, Foam Rubber	4
5	43611	(000000–005999)	Washer, Nylon	2
6	26015	(000000–005999)	Fastener	2
7	25656	(000000–005999)	Fastener, Winghead	2
8	67004	(000000–005999)	Clip, Finger Grip	4
9	01617	(000000–005999)	Hose, Vacuum	1
10	01613	(000000–005999)	Nozzle, Master	1
11	01615	(000000–005999)	Tool, Crevice	1
12	01618	(000000–005999)	Wand	2
13	04057	(000000–005999)	Hinge	1
14	06121	(000000–005999)	Chain	2
15	43363	(000000–005999)	Hook, S	2
16	04060	(000000–005999)	Cover, Vacuum Wand	1
17	49302	(000000–005999)	Latch, Adjustable	2
18	51787	(000000–005999)	Bumper, Rubber	2

Fig. 12 – Wand Vacuum Fan Group

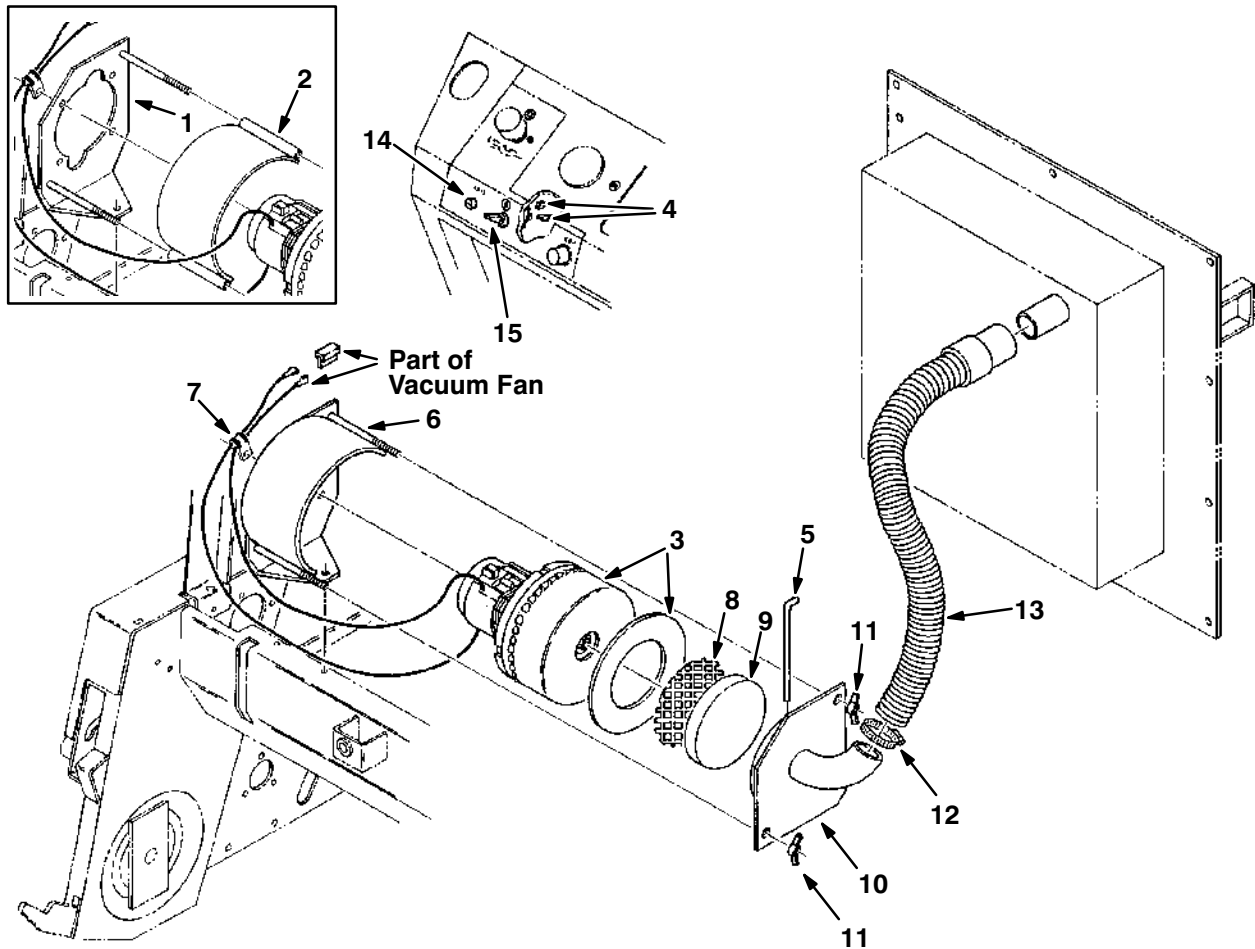

03112

NOTE: Vacuum Wand Kit, TENNANT Part Number 01031, Includes Fig. 11 and 12.

Key	TENNANT Part No.	Machine Serial Number	Description	Qty.
1	01466	(000000–002638)	Mount, Vacuum Fan (Replaced by 06655)	1
2	01467	(000000–002638)	Shield, Vacuum Fan (Replaced by 06655)	1
3	01475	(000000–)	Fan, Vacuum Assembly	1
4	68106	(000000–)	Tab, Terminal	2
5	01635	(000000–)	Rod, Retainer	1
6	06655	(002639–)	Mount, Vacuum Fan	1
7	26395–2	(000000–)	Clamp, Cable	1
8	63143	(000000–)	Screen	1
9	63144	(000000–)	Filter, Vacuum Fan	1
10	06657	(000000–)	Cover, Vacuum Fan	1
11	39272	(000000–)	Nut, Wing	2
12	11531	(000000–)	Clamp, Worm Drive	1
13	29693	(000000–)	Hose and Cuff Assembly	1
14	63030	(000000–)	Breaker, Circuit	1
15	70302	(000000–)	Switch	1

Fig. 13 – Vacuum Wand Group

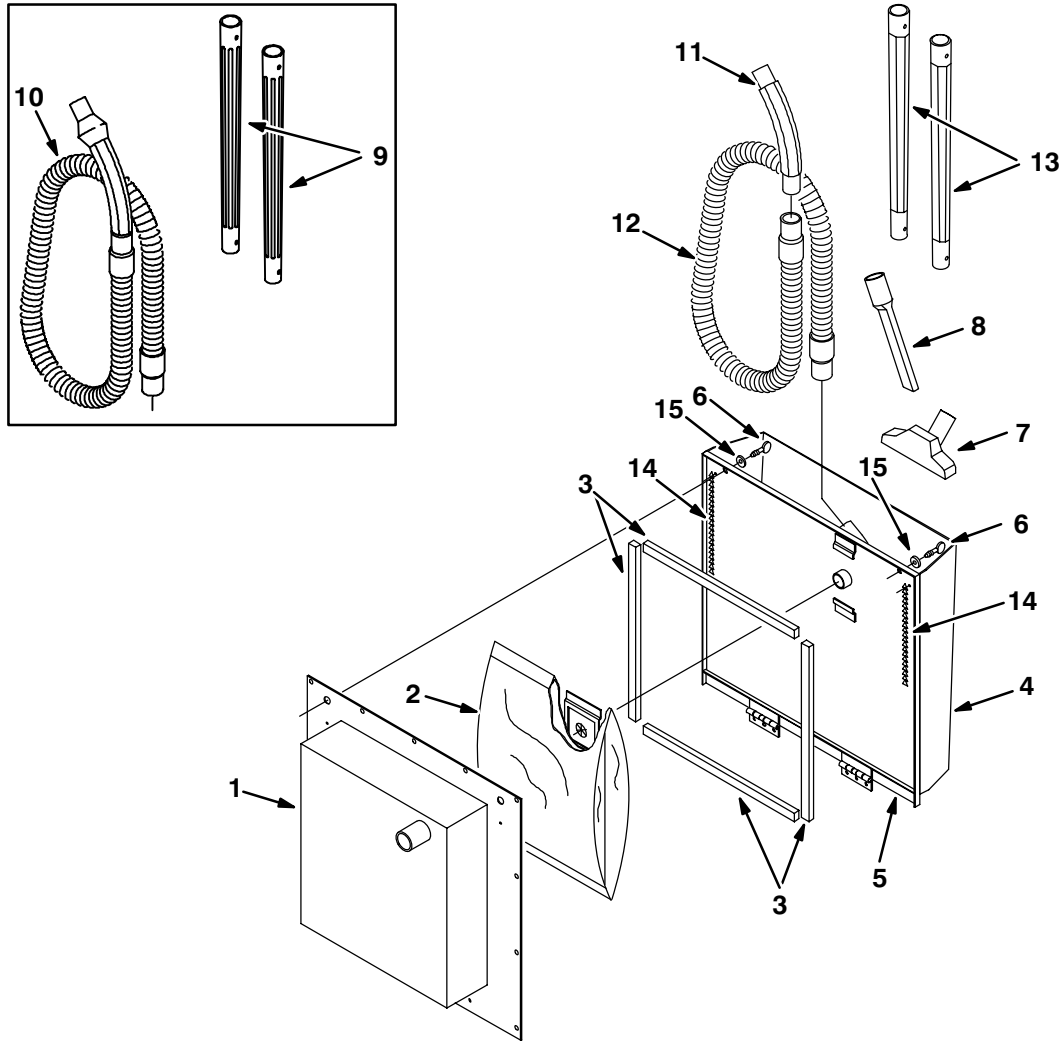

NOTE: Vacuum Wand Kit, TENNANT Part Number 41274, Includes Fig. 12 and 13.

06345

Key	TENNANT Part No.	Machine Serial Number	Description	Qty.	
1	61100	(006000–)	Box Wldt, Vac	1	
2	01654	(006000–)	Bags, Vacuum (Disposable)	3	
3	53461–2	(006000–)	Seal, Foam Rubber	4	
▽	65360	(006000–)	Cover Assembly, Vacuum Wand	1	
▲	4	61078	(006000–)	Cover, Vacuum Wand	1
▲	5	65359	(006000–)	Plate, Vacuum Box	1
6	25656	(006000–)	Screw, Thumb	2	
7	01613	(006000–)	Nozzle, Master	1	
8	01615	(006000–)	Tool, Crevis	1	
9	01618	(006000–007063)	Wand, Extension	2	
10	61668	(006000–007063)	Replacment Kit, Hose, Wand F/01617	1	
11	05584	(007064–)	Hose End, Curved	1	
12	05594	(007064–)	Hose Assy, Vacuum Wand	1	
13	05579	(007064–)	Wand, Vacuum	2	
14	65357	(006000–)	Chain, Sash	2	
15	32490	(006000–)	Washer, flt	2	

Fig. 14 – Battery Kit, Wet

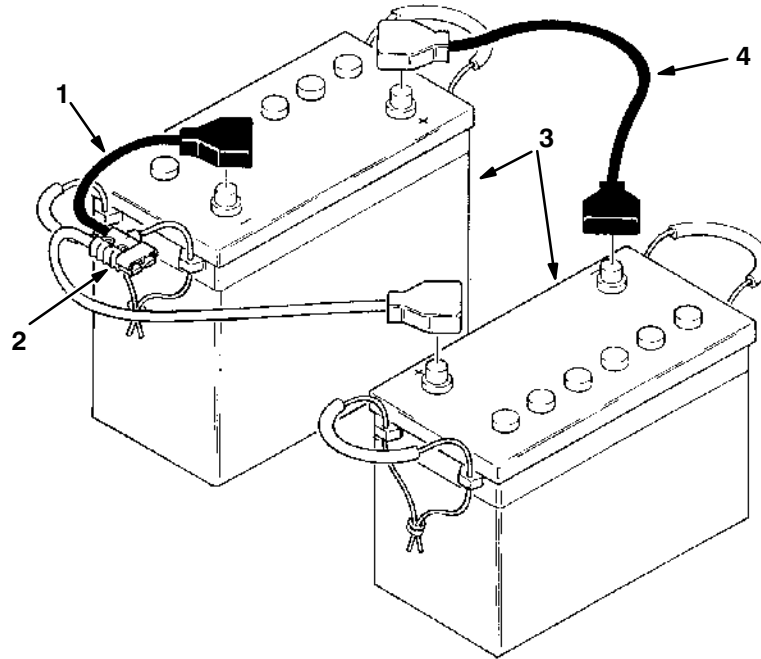

04319

Key	TENNANT Part No.	Machine Serial Number	Description	Qty.
▽	06480	(000000–)	Battery Kit, Wet	1
▲▽ 1	01373	(000000–)	Cable Assembly, Battery	1
▲▲ 2	24881	(000000–)	Connector, Grey	1
▲ 3	01537	(000000–)	Battery, 140 A/h, Wet	2
▲ 4	01368	(000000–)	Wire Assembly	1

Fig. 15 – Battery Kit, Dry

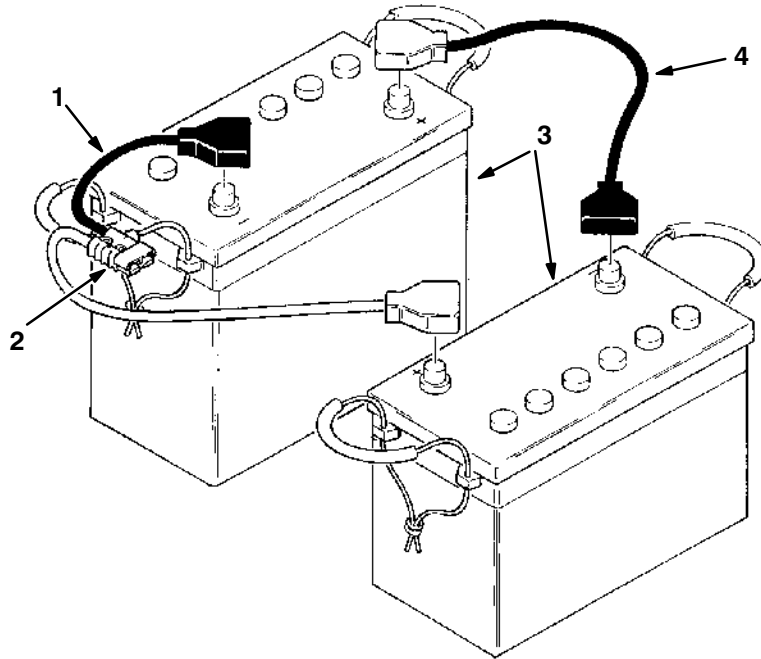

04320

Key	TENNANT Part No.	Machine Serial Number	Description	Qty.
▽	06792	(000000–)	Battery Kit, Dry	1
▲▽ 1	01373	(000000–)	Cable Assembly, Battery	1
▲▲ 2	24881	(000000–)	Connector, Grey	1
▲ 3	01564	(000000–)	Battery, 140 A/h, Dry	2
▲ 4	01368	(000000–)	Wire Assembly	1

Fig. 16 – Battery Charger and Timer Group

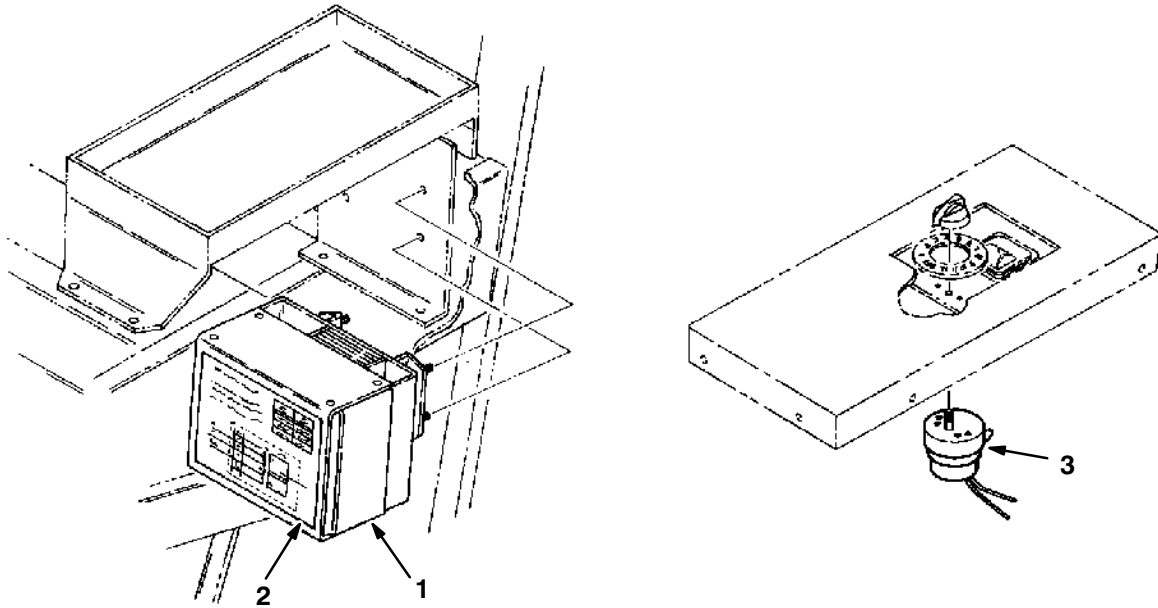

03127

Key	TENNANT Part No.	Machine Serial Number	Description	Qty.
▽ 1	60516	(000000–005999)	Replacement Kit, Charger, Battery, 50 Hz	1
▲ 2	19889	(000000–005999)	Decal, Charger	1
3	41599	(000000–005999)	Switch, Timer, 50Hz	1

Fig. 17 – Battery Charger and Timer Group

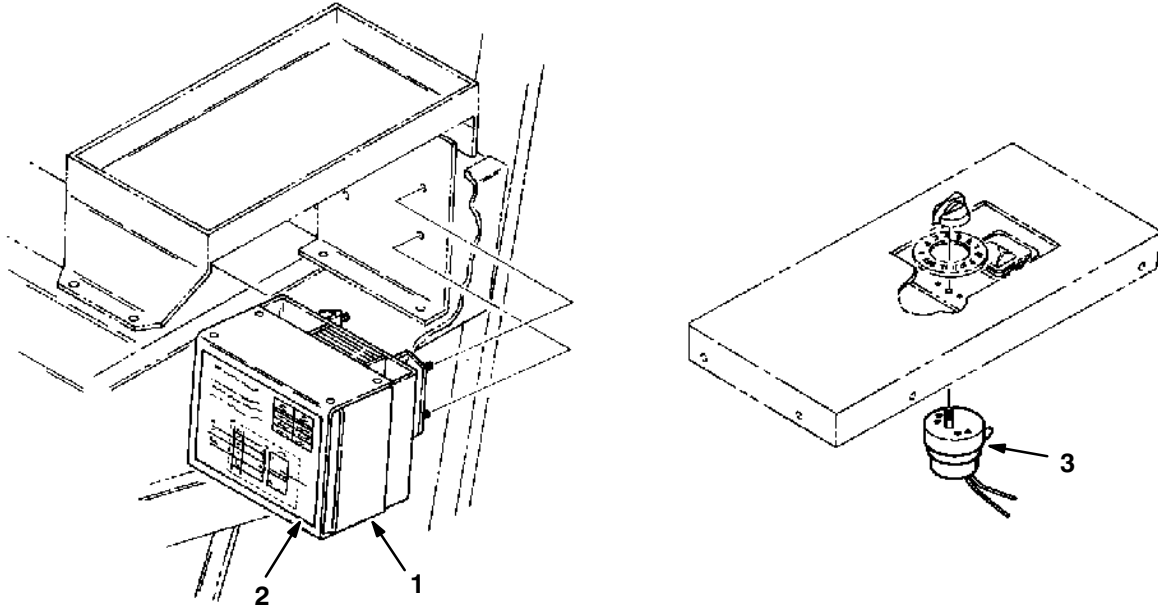

06908

Key	TENNANT Part No.	Machine Serial Number	Description	Qty.
▽ 1	60520	(006000–006822)	Replacement Kit, Charger, Battery, 50 Hz	1
▲ 2	19889	(006000–006822)	Decal, Charger	1
3	41599	(006000–006822)	Switch, Timer, 50Hz	1

Fig. 18 – Battery Charger and Timer Group

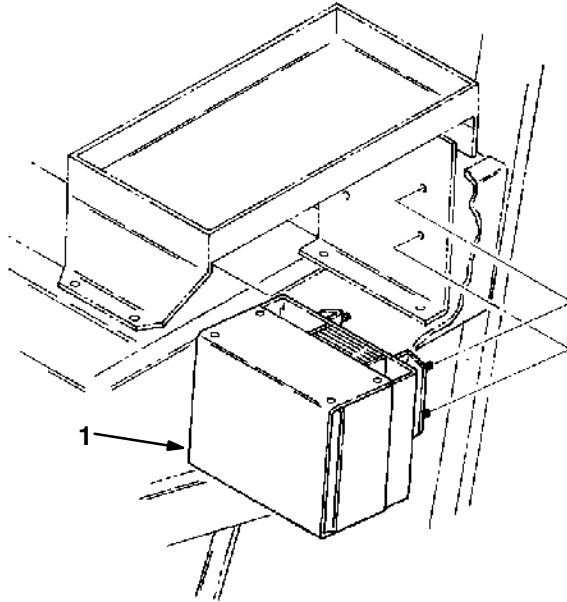

06909

Key	TENNANT Part No.	Machine Serial Number	Description	Qty.
1	50116	(000000–)	Charger, Battery, 50 Hz	1

Fig. 19 – Battery Charger Group

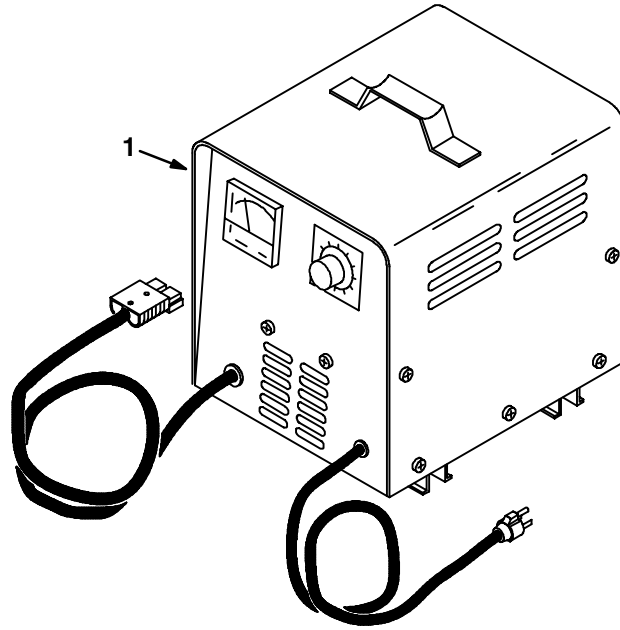

05162

Key	TENNANT Part No.	Machine Serial Number	Description	Qty.
1	50094	(000000–)	Charger, Battery, 60 Hz	1

Fig. 20 – Fire Extinguisher Kit

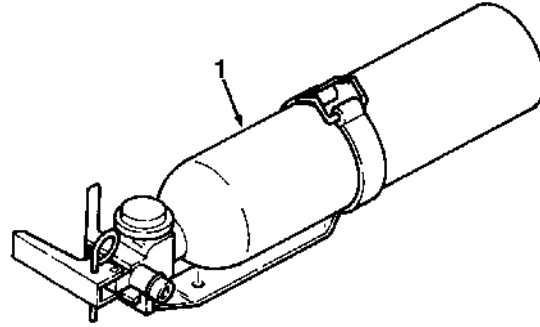

02597

Key	TENNANT Part No.	Machine Serial Number	Description	Qty.
▽	46938	(000000–)	Extinguisher Kit, Fire	1
▲ 1	25312	(000000–)	Extinguisher, Fire	1

Fig. 21 – Battery Gauge Kit

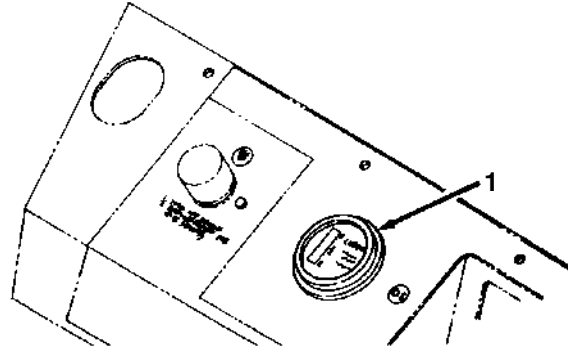

07033

Key	TENNANT Part No.	Machine Serial Number	Description	Qty.
∇	06734	(000000–006822)	Gauge Kit, Battery	1
▲ 1	01378	(000000–006822)	Gauge, Battery	1

Fig. 22 – Double Wheel Kit

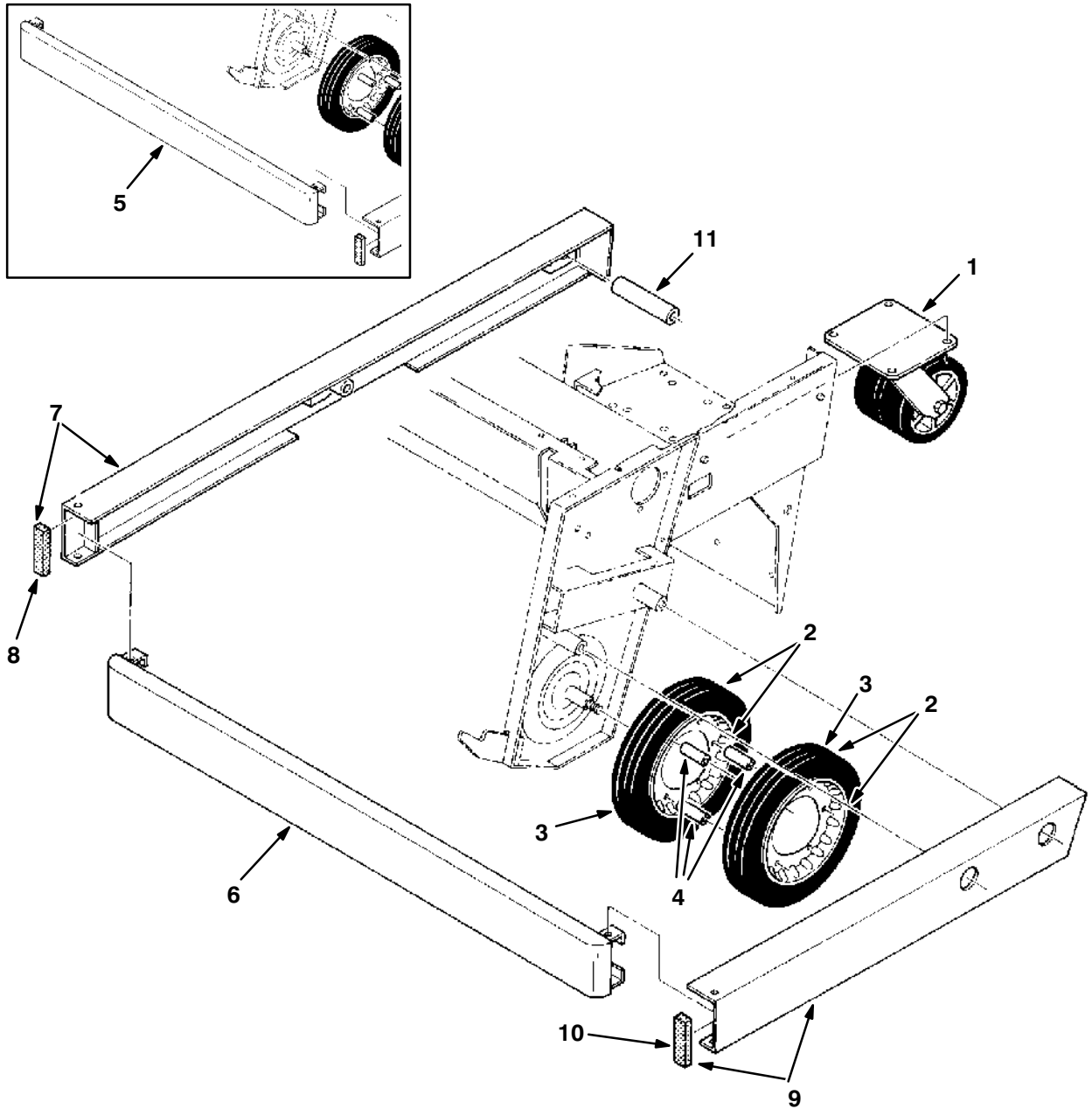

07031

Key	TENNANT Part No.	Machine Serial Number	Description	Qty.
▽	01040	(000000–)	Double Wheel Kit	1
▲	1	01266 (000000–)	Caster, Dual Wheeled	1
▲▽	2	47807 (000000–)	Tire and Wheel Assembly Non Marking	4
▲▲	3	28311 (000000–)	Tire	1
▲	4	27055 (000000–)	Sleeve	6
▲	5	61325 (000000–007142)	Replacement Kit, Front Bumper F/06812	1
▲	6	61323 (007143–)	Bumper, Front	1
▲▽	7	06813 (000000–)	Bumper Assembly, R.H.	1
▲▲	8	28988–1 (000000–)	Seal, Foam Rubber	1
▲▽	9	06815 (000000–)	Bumper Assembly, L.H.	1
▲▲	10	28988–1 (000000–)	Seal, Foam Rubber	1
▲	11	06826 (000000–)	Tube	1

Fig. 23 – Dual Caster Group

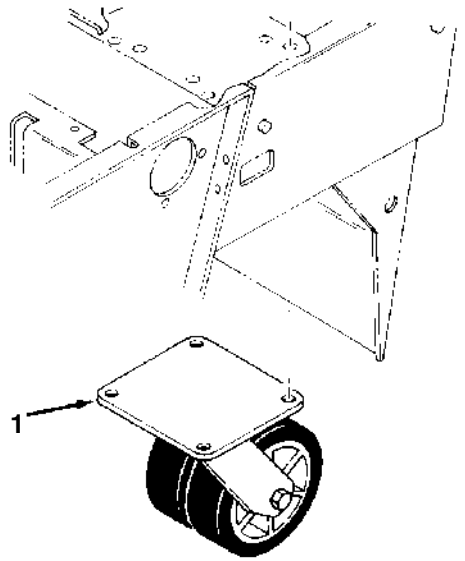

03119

Key	TENNANT Part No.	Machine Serial Number	Description	Qty.
1	01266	(000000–)	Caster, Dual Wheeled	1

Fig. 24 – Plastic Hopper Kit

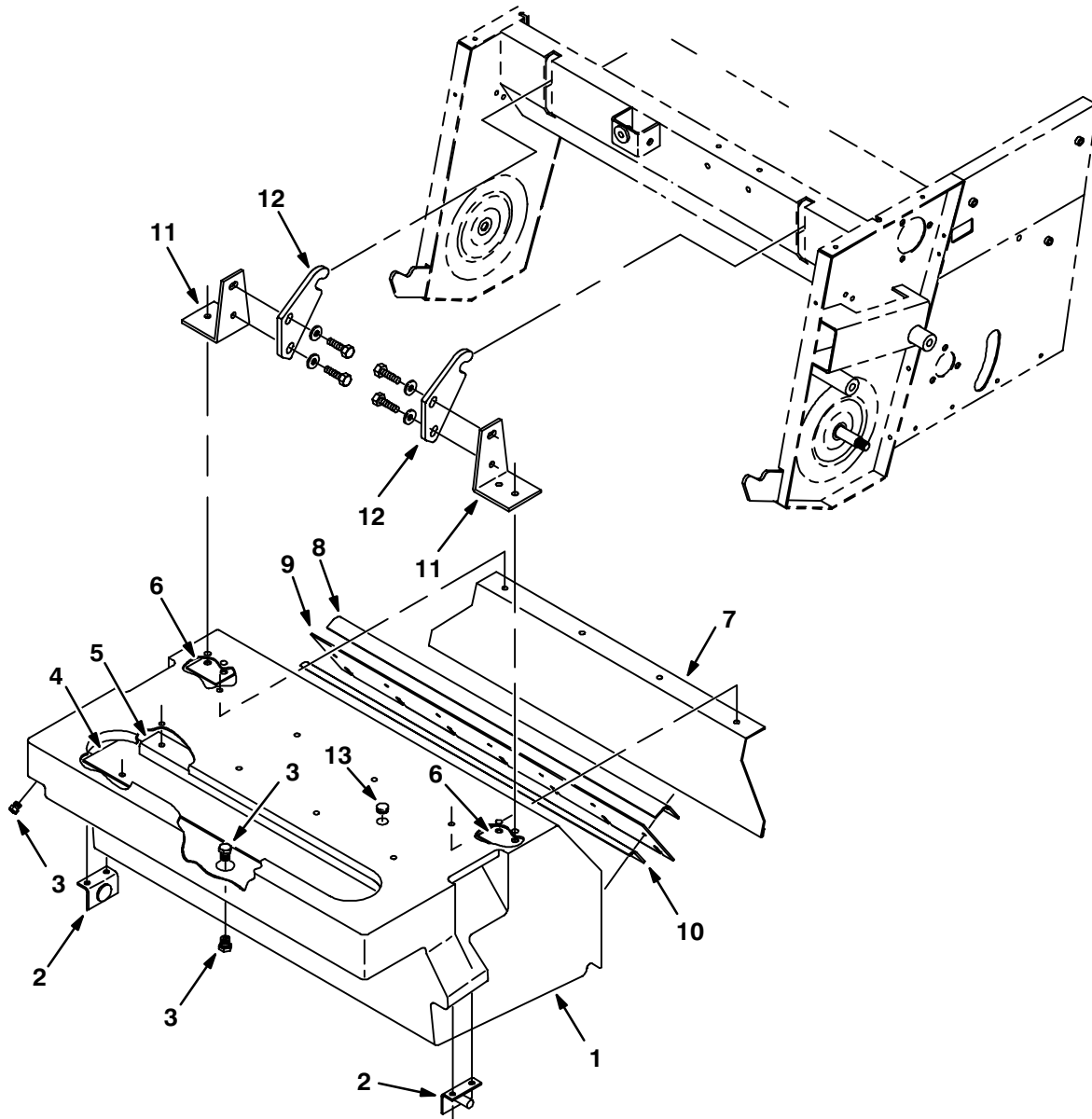

06897

Key	TENNANT Part No.	Machine Serial Number	Description	Qty.
∇	61119	(000000–)	Hopper Kit Plastic 186	1
▲ 1	09363	(000000–)	Hopper, Swppr/Scrbr	1
▲ 2	09481	(000000–)	Bracket, Support Pin	2
▲ 3	50896	(000000–)	Ftg–Plug Npt 02Pm Hx Hd Plstc	3
▲ 4	61086	(000000–)	Strip, Deflector	1
▲ 5	50930	(000000–)	Angle, Stiffener Hopper	1
▲ 6	61087	(000000–)	Plate, Nut	2
▲ 7	09484	(000000–)	Angle, Deflector	1
▲ 8	09483	(000000–)	Angle, Hopper Lip Retainer	1
▲ 9	50775	(000000–)	Rubber, Hopper Lip	1
▲ 10	41306	(000000–)	Angle, Lip Retainer, Lower	1
▲ 11	09482	(000000–)	Bracket, Mounting	2
▲ 12	01132	(000000–)	Plate, Hopper Catch	2
▲ 13	50896	(000000–)	Ftg–Plug Npt 02Pm Hx Hd Plstc	1

Fig. 25 – Fine Particle Filter Kit

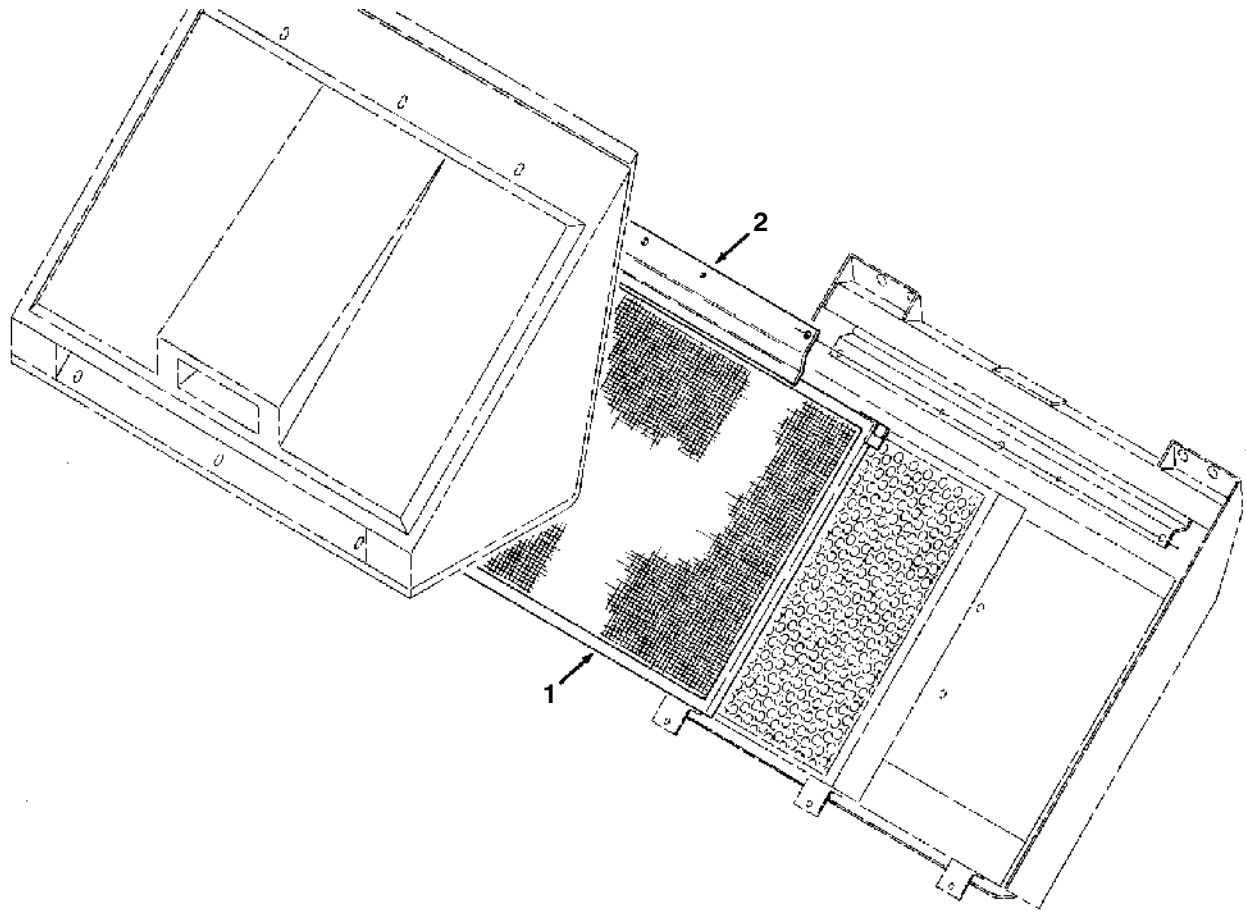

07558

Key	TENNANT Part No.	Machine Serial Number	Description	Qty.
▽	61450	(000000–)	Filter Kit, Fine Particle	1
▲ 1	32557	(000000–)	Filter Assembly, Fine Particle	1
▲ 2	01154	(000000–)	Bracket, Hold Down	1
	61447	(000000–)	Sheave	1

Fig. 26 – Lift and Tie-Down Kit

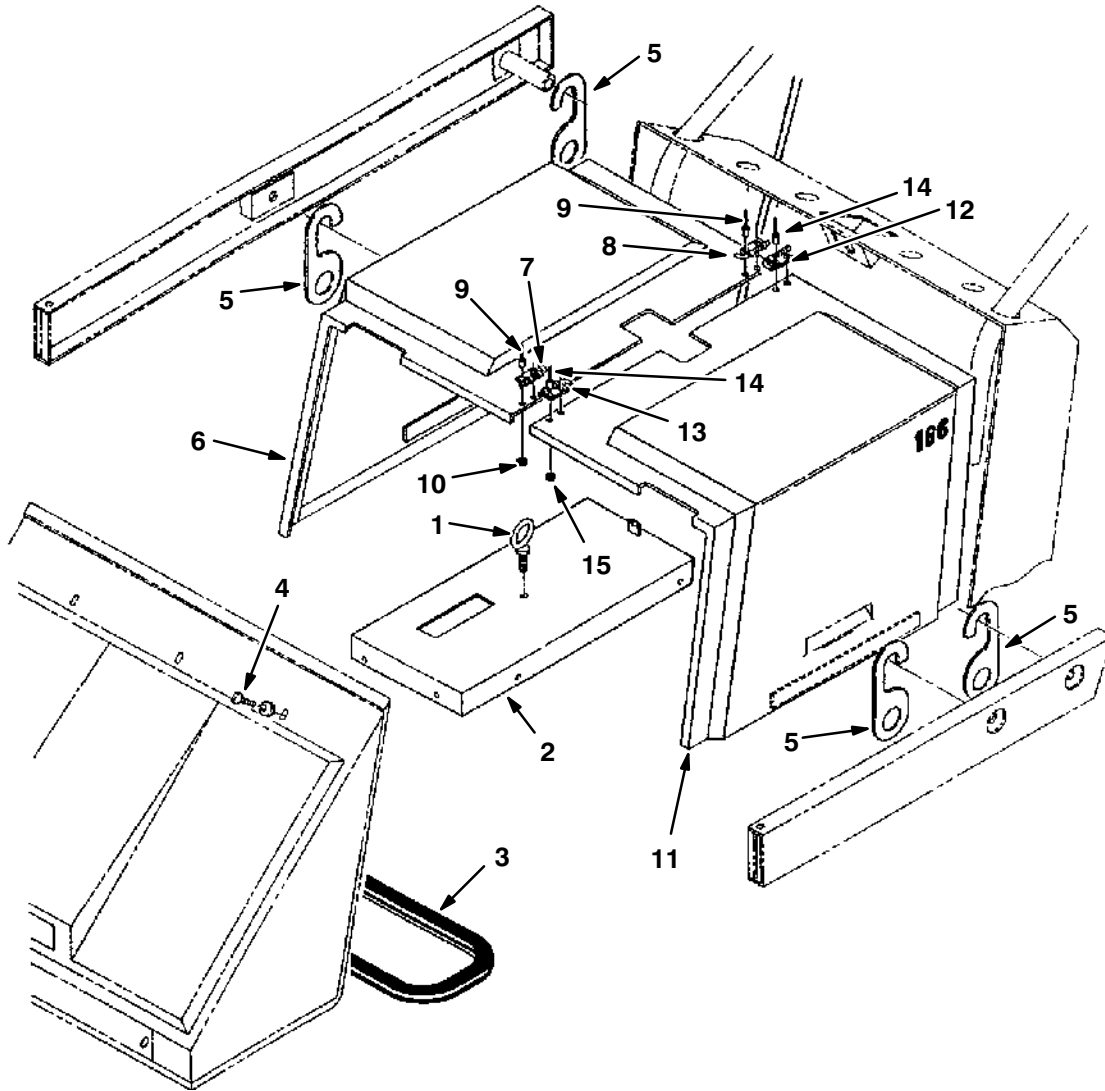

08034

Key	TENNANT Part No.	Machine Serial Number	Description	Qty.
∇	65367	(000000–)	Lift and Tie-Down Kit	1
▲∇	65363	(000000–)	Lift Kit	1
▲▲ 1	78556	(000000–)	Eyebolt	1
▲▲ 2	65371	(000000–)	Brace, Center	1
▲ 3	12082	(000000–)	Cover, Protective Filter	1
▲ 4	78557	(000000–)	Screw, Thumb	6
▲ 5	08077	(000000–)	Tie-Down	4
▲∇ 6	70311	(000000–)	Cover Assembly, R.H.	1
▲▲ 7	50832	(000000–)	Hinge, Pull Pin L.H.	1
▲▲ 8	50835	(000000–)	Hinge, Pull Pin R.H.	1
▲▲ 9	01335	(000000–)	Rivet, Soft	4
▲▲ 10	64757	(000000–)	Bumper, Rubber	3
▲∇ 11	70312	(000000–)	Cover Assembly, L.H.	1
▲▲ 12	50832	(000000–)	Hinge, Pull Pin L.H.	1
▲▲ 13	50835	(000000–)	Hinge, Pull Pin R.H.	1
▲▲ 14	01335	(000000–)	Rivet, Soft	4
▲▲ 15	64757	(000000–)	Bumper, Rubber	3

Fig. 27 – Documentation Group

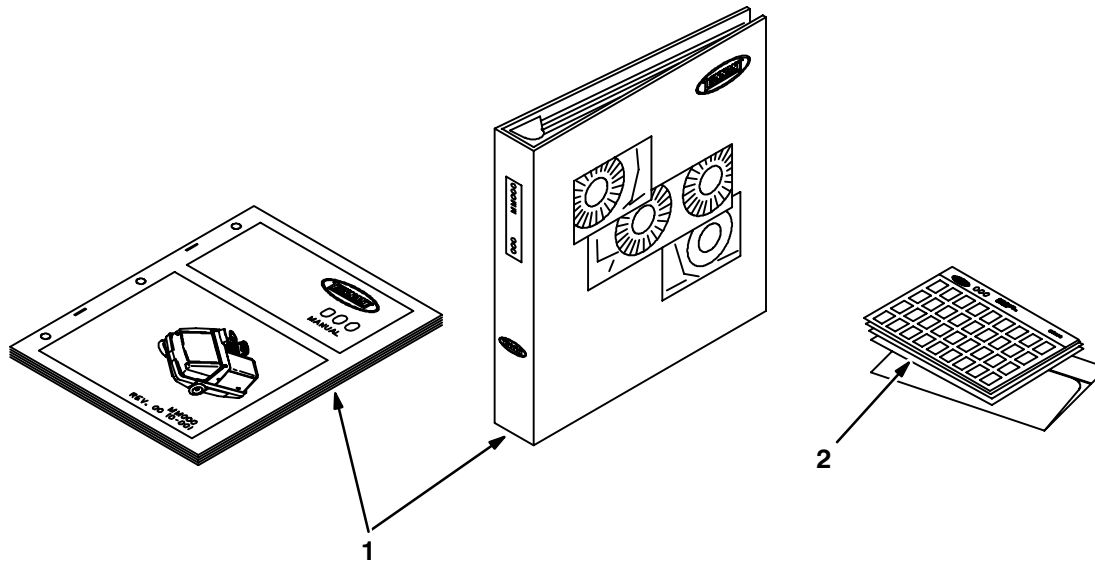

10324/07501

Ref.	TENNANT Part No.	Machine Serial number	Description	Qty.
1	MM160	(000000–)	Manual Pkg 186E	1
2	85160	(000000–)	Manual–Fiche Pkg 186E	1

CONTENTS

	Page
Fig. 1 – Motor Breakdown	9-2

Fig. 1 – Motor Breakdown

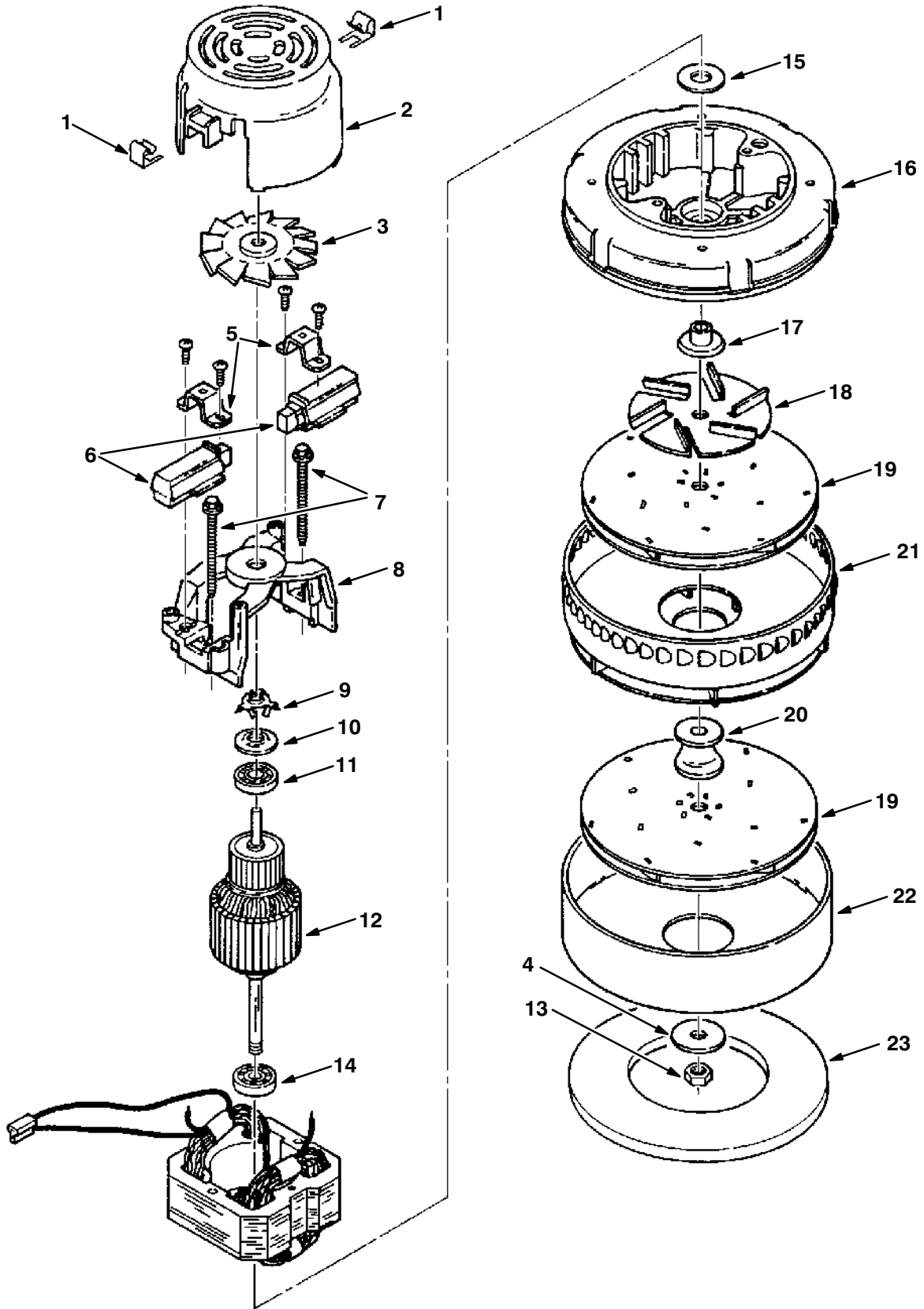

Fig. 1 – Motor Breakdown

Key	TENNANT Part No.	Manufacturer Serial Number	Description	Qty.
▽	01475	(000000–)	Fan Assembly, Vacuum	1
▲ 1	01967	(000000–)	Clip	2
▲ 2	37926	(000000–)	Housing	1
▲ 3	61298	(000000–)	Fan	1
▲ 4	18632	(000000–)	Washer	1
▲ 5	01982	(000000–)	Clamp	2
▲ 6	32323	(000000–)	Brush	2
▲ 7	01969	(000000–)	Screw	2
▲ 8	01983	(000000–)	Bracket	1
▲ 9	01856	(000000–)	Spring	1
▲ 10	37909	(000000–)	Disc	1
▲ 11	01842	(000000–)	Bearing	1
▲ 12	18633	(000000–)	Armature	1
▲ 13	37929	(000000–)	Nut	1
▲ 14	01837	(000000–)	Bearing	1
▲ 15	37912	(000000–)	Washer	1
▲ 16	01970	(000000–)	Bracket	1
▲ 17	18627	(000000–)	Spacer	1
▲ 18	01971	(000000–)	Fan	1
▲ 19	18628	(000000–)	Fan, Vacuum	2
▲ 20	18630	(000000–)	Spacer	1
▲ 21	18629	(000000–)	Fan, Stationary	1
▲ 22	18631	(000000–)	Shell	1
▲ 23	63319	(000000–)	Seal	1
▲	51408	(000000–)	Terminal	2
▲	51407	(000000–)	Connector	1

SECTION 10

CONTENTS

	PAGE
PART NUMBER TO PAGE NUMBER CROSS REFERENCE LIST	10-2

CROSS REFERENCE

PART NUMBER TO PAGE NUMBER CROSS REFERENCE LIST

Part Number	Page Number	Part Number	Page Number
MM160	8-32	01286	8-5, 8-13
00500-1	6-14	01288	6-14
00500-10	8-14	01306	6-17
00500-4	6-7, 6-9, 6-16	01314	6-18
00911	6-13, 8-7	01316	6-15
00960	6-16	01317	6-5
01040	8-27	01318	6-5
01047	6-13	01319	6-17
01053	8-14	01320	6-17
01058	6-13	01324	6-11
01064	6-17	01329	8-3
01094	6-11	01331	6-7
01096	6-16	01334	8-7
01098	6-11	01335	6-7, 6-9, 6-17, 7-3, 7-5, 8-31
01101	6-11	01342	8-3
01104	6-7, 6-9, 6-16	01343	8-3
01105	6-11	01344	8-7
01112	6-7, 6-9	01345	8-7
01113	6-7, 6-9	01347	8-7
01115	6-7, 6-9	01353	6-23, 7-7
01119	6-7, 6-9	01355	6-23, 7-7
01120	6-7, 6-9	01362	6-14
01121	6-15	01368	6-11, 8-19, 8-20
01131	6-5	01373	6-11, 8-19, 8-20
01132	6-15, 8-29	01376	6-11
01134	6-7, 6-9	01377	6-11
01138	6-12	01378	8-26
01139	6-12	01379	6-11
01141	6-12	01392	8-16
01142	6-7, 6-9	01395	7-3
01144	6-7, 7-3	01398	8-16
01150	6-7, 6-9	01413	8-5, 8-13
01154	8-30	01421	6-11
01157	6-15	01438	8-14
01166	6-5	01439	8-14
01184	6-16	01444	8-14
01188	6-16	01466	8-10, 8-17
01191	7-3, 7-5	01467	8-10, 8-17
01192	6-7, 6-9	01469	8-14
01194	6-7	01470	8-14
01195	6-7	01471	8-14
01198	6-7	01473	8-14
01199	6-7, 6-9	01475	8-10, 8-17, 9-3
01200	6-14	01476	8-14
01217	6-14	01479	8-14
01234	6-5	01489	7-3
01235	6-5	01490	7-3, 7-5
01236	6-12	01491	7-3, 7-5
01246	6-5	01492	8-5, 8-13
01247	6-5	01493	6-18, 6-19, 7-3
01251	6-5	01494	8-5, 8-13
01255	6-16	01495	8-3
01261	8-10, 8-11	01498	8-7
01266	8-27, 8-28	01499	8-5, 8-13
01271	6-7	01500	6-13
01272	6-15	01502	8-8
01274	6-7	01503	7-7, 7-9
01285	8-3		

CROSS REFERENCE

Part Number	Page Number	Part Number	Page Number
01504	8-3	02431	7-3, 7-5
01506	8-14	02712	6-16
01507	8-7	03292B	6-15
01508	8-7	03856	6-2, 8-8
01510	8-7	04057	8-16
01511	8-7	04060	8-16
01513	6-13	04930	6-11, 7-3, 7-5
01517	8-7	05579	8-18
01520	8-5, 8-13	05584	8-18
01525	8-5, 8-13	05594	8-18
01532	8-7	06121	6-17, 8-16
01534	8-5, 8-13	06461	7-3
01536	8-5, 8-13	06462	7-3
01537	6-11, 8-19	06464	6-7
01538	7-3	06468	6-7
01544	7-3	06469	6-5
01551	7-3, 7-5	06477	6-17
01554	8-14	06478	8-3
01555	8-7	06480	8-19
01559	8-7	06481	8-8
01564	8-20	06482	8-16
01568	8-3	06615	8-3
01570	8-3	06619	8-7
01576	8-3	06620	8-3
01579	8-3	06645	8-3
01580	8-3	06651	6-13
01584	8-3	06654	8-3
01613	8-16, 8-18	06655	8-10, 8-17
01615	8-16, 8-18	06657	8-10, 8-17
01617	8-16	06659	6-17
01618	8-16, 8-18	06660	6-17
01621	8-3	06662	6-13
01622	8-3	06734	8-26
01628	8-5	06741	8-16
01633	8-5	06762	8-5, 8-13
01635	8-10, 8-17	06792	8-20
01636	8-8	06796	8-5
01639	8-5, 8-13	06800	8-3
01640	8-5, 8-13	06813	8-27
01641	7-5	06815	8-27
01642	8-3	06826	8-27
01643	8-3	07259	6-12
01644	8-3	07316-15	6-13
01654	8-18	08036	6-7
01657	6-2, 8-8	08037	6-7, 6-9
01739	6-7, 6-9, 7-3, 7-5	08041	6-7
01740	6-7, 6-9, 7-3, 7-5	08057	6-2, 6-5
01780	6-2, 8-8	08067	8-3
01837	9-3	08076	8-11
01842	9-3	08077	8-31
01856	9-3	08078	8-11
01967	9-3	08086	6-7
01969	9-3	08087	6-5
01970	9-3	08091	8-5, 8-13
01971	9-3	08092	8-5, 8-13
01982	9-3	08093	8-5, 8-13
01983	9-3	08142	6-14
02076	6-11	08143	6-16
02221	6-16	08145	6-14
02424	6-11	08147	6-12

CROSS REFERENCE

Part Number	Page Number	Part Number	Page Number
08152	6-14	15173	6-13
08155	6-13	16934	6-16
08156	6-5	17461	8-9
08157	6-17	18125	6-13
08703	6-2, 6-5	18136	6-12
08823	7-3, 7-5	18276	6-13
09338	6-18, 6-19	18627	9-3
09350	6-23, 7-7	18628	9-3
09351	6-23	18629	9-3
09352	6-18	18630	9-3
09363	8-29	18631	9-3
09367	6-9, 7-5	18632	9-3
09400	6-9	18633	9-3
09408	6-9	18645	6-5
09433	6-9	19889	8-21, 8-22
09473	6-9	20050	6-12
09480	6-5	20215	8-5, 8-13
09481	8-29	20267	8-5, 8-13
09482	8-29	20634	6-14, 6-17
09483	8-29	21570	6-19
09484	8-29	22297	8-5, 8-13
09494	6-9, 7-5	22328	6-7
09796	6-11, 7-3	23072	7-3, 7-5
10125	7-3, 7-5	23072-1	7-3, 7-5
10218	8-5, 8-13	23217	6-12
10224	6-16	23481	6-16
10226	6-5	23498	6-16
10232	6-20	23524-3	8-14
10352	6-16	24881	6-11, 8-19, 8-20
10361	8-7	25312	8-25
10362	6-16	25656	8-16, 8-18
10368	8-15	25887	6-14
10372	8-15	25920	6-17
10378	8-15	25921	6-7, 6-9
10379	8-15	26015	8-16
10381	8-15	26103	6-12
10383	8-3	26212	6-13
10386	8-7	26239	6-13, 8-7
10387	8-3	26395	7-3, 7-5
10632-12	6-7, 6-9	26395-2	8-10, 8-17
11398	6-7, 6-9	26414	8-11
11531	8-5, 8-10, 8-13, 8-17	26509	6-13
12053	8-3	27055	8-27
12063	6-5	28002	6-3
12066	6-11	28006	6-3
12067	6-7	28006N	6-3
12075	8-5	28007P	6-3
12077	8-5	28010	6-13, 6-14
12078	8-3	28014A	6-14
12081	8-3	28025	6-2, 6-5
12082	8-31	28026	6-2, 6-5
12764	6-15	28041	6-13
12768	6-15	28061	6-14
12769	6-15	28066	6-12
12775	6-18	28071	6-5
12955	6-7, 6-9	28072	6-2, 6-5
12966	6-7	28074	6-12
12990	6-14	28078	6-13
14330	6-7, 6-12, 8-7	28081	6-2, 6-5, 6-15
14331	8-7	28084	6-13

CROSS REFERENCE

Part Number	Page Number	Part Number	Page Number
28096N	6-3	30172	6-20
28096P	6-3	30174	6-14
28121	6-13	30175	6-14
28144	6-13	30200	6-7
28168	6-13	30205	6-9
28172	6-3	30246	8-5, 8-13
28194	6-13	31025	6-15
28195	6-13	31037	8-9
28223	6-13	31039	8-9
28234	6-3	31172	6-17
28235	6-3	31173	6-17
28250	6-2, 6-5	31203	6-18
28272	6-14	31204	6-18, 6-19
28277-1	6-2, 6-5	32323	9-3
28277-2	6-2, 6-5	32490	8-18
28281	8-14	32557	8-30
28311	8-27	32815	6-11
28387	6-13	32922	6-11, 7-3, 7-5
28388	6-13	34810	6-18, 6-19
28499	6-5	35927	8-14
28546	6-14	37909	9-3
28574	8-3	37912	9-3
28660	6-3	37926	9-3
28712	6-13	37929	9-3
28714	6-13	39021	8-14
28755	6-16	39215	7-3, 7-5
28840	6-13	39224	7-3, 7-5
28841	6-12	39272	8-10, 8-17
28845A	6-13	39562	6-12
28849-1	6-13	40352	6-12
28850A	6-12	40678	6-11
28852	6-13	41186	6-15
28862	6-12	41286	6-9
28865	6-14	41288	6-17
28867	6-13	41289	6-11
28868	6-12	41292	6-16
28949	6-13	41294	8-11
28950-2	8-5, 8-13	41305	6-5
28976	6-13	41306	8-29
28977	6-13	41599	8-21, 8-22
28979	6-13	41609	6-11, 7-5
28988-1	6-5, 8-27	41620	6-15
29005	6-12	43242	8-3, 8-5
29006	6-3	43363	8-16
29406	6-3, 8-9	43454	8-7
29408	6-3	43516A	8-3
29545	6-7, 6-9, 8-15	43611	8-7, 8-16
29585	8-9	44078	6-18, 7-3, 7-5
29586	8-9	44340	6-11
29592	8-9	44893	6-17
29653	8-8	44906	8-7
29664	8-5, 8-13	45086	8-7
29688	6-11	45089	8-7
29693	8-10, 8-17	45154	6-3
29704	7-3, 7-5	45937	8-5, 8-13
29982	6-5	45938-1	8-5, 8-13
29991	6-18	46139	8-11
30147	6-14	46140	8-11
30148	6-14	46236	6-11, 8-3, 8-11
30169	6-17	46820	6-7, 6-9, 6-16

CROSS REFERENCE

Part Number	Page Number	Part Number	Page Number
46938	8-25	60595	8-3
47037	6-2	61059	7-5
47069	6-16	61062	7-5
47807	8-27	61063	6-9
49266	8-11	61067	6-9
49302	8-16	61072	7-12
49351-3	8-5, 8-13	61074	7-12
49708	6-13	61078	8-18
50049	6-11	61086	8-29
50050	6-11	61087	8-29
50094	8-24	61100	8-18
50116	8-23	61104	6-11, 7-3, 7-5
50470	7-7, 7-9	61106	6-11, 7-3, 7-5
50474	6-11, 7-7, 7-9	61119	8-29
50711	6-5	61123	6-15
50744	6-9	61289	6-14
50775	8-29	61291	6-14
50802	6-25, 7-9	61298	9-3
50803	6-25, 7-9	61322	6-5
50821	6-9	61323	8-27
50828	6-19	61324	6-5
50832	6-9, 7-5, 8-31	61325	8-27
50835	6-9, 7-5, 8-31	61326	6-5
50843	6-21	61327	6-5
50896	8-29	61414	6-14
50909	6-9	61447	8-30
50910	6-9	61450	8-30
50926	6-21	61668	8-18
50930	8-29	61671	6-27, 7-11
50931	6-5	62170-1	6-7
50936	6-9	63030	6-19, 8-10, 8-17
50938	6-5	63034	8-8
51137	6-14	63038	8-8
51407	9-3	63143	8-10, 8-17
51408	9-3	63144	8-10, 8-17
51787	6-15, 8-16	63266	6-18
52508	6-9	63310	8-5, 8-13
53461-2	8-18	63319	9-3
54121	6-17	63327	8-8
55130	6-17	63329	8-8
56992	6-18, 6-19	63785	8-14, 8-15
57496	6-13, 6-14, 8-14	63967	6-2, 8-8
57751	6-18, 6-19, 7-3, 7-5	64595	6-17
57803	6-18, 6-19, 7-3, 7-5	64730	6-18, 6-19
57889	8-7	64757	6-7, 6-9, 7-3, 7-5, 8-31
58311	6-9	65357	8-18
58494	6-17	65359	8-18
60027	6-2	65360	8-18
60470	6-16	65363	8-31
60488	6-27, 7-11	65367	8-31
60510	6-19	65371	8-31
60515	6-11	65374	6-19
60516	8-21	65375	6-17
60519	6-11	65548	6-5
60520	8-22	67004	8-16
60523	6-11	68106	8-10, 8-17
60525	7-11	69582	6-9
60526	7-12	70302	8-17
60527	7-5	70311	8-31
60594	7-5	70312	8-31

Part Number	Page Number
70320	6-19, 8-10
70323	6-19
70326	6-9
75774	8-7
76426	8-5, 8-13
78556	8-31
78557	8-31
82733	6-16
82747	6-7, 6-18, 6-19, 8-14
85160	8-32
87246	6-9
87299	6-16
87337	8-5, 8-13
87550	6-17
94149	6-13
94150	6-13
94413	6-13

Fold along dotted lines

Tape here



NO POSTAGE
NECESSARY
IF MAILED
IN THE
UNITED STATES

BUSINESS REPLY MAIL

FIRST CLASS MAIL PERMIT NO. 94 MINNEAPOLIS, MN

POSTAGE WILL BE PAID BY ADDRESSEE

TENNANT COMPANY

Technical Publications #15
701 North Lilac Drive
P.O. Box 1452
Minneapolis, MN 55440-9947



Fold along dotted lines

Tape here



NO POSTAGE
NECESSARY
IF MAILED
IN THE
UNITED STATES

BUSINESS REPLY MAIL

FIRST CLASS MAIL PERMIT NO. 94 MINNEAPOLIS, MN

POSTAGE WILL BE PAID BY ADDRESSEE

TENNANT COMPANY

Technical Publications #15
701 North Lilac Drive
P.O. Box 1452
Minneapolis, MN 55440-9947



TENNANT COMPANY SERVICE LITERATURE AVAILABLE...

A variety of information is available to you in forms to suit your needs. The following is a list of those publications that relate to the Model 186 family of machines:

Machine Model	Publication	Form	TENNANT Part No.
186	Operation, Maintenance, and Parts Manual	Printed	MM159
186E	Operation, Maintenance, and Parts Manual	Printed	MM160
186	Operation, Maintenance, and Parts Manual	Microfiche	85159
186E	Operation, Maintenance, and Parts Manual	Microfiche	85160
186	Operator Handbook	Printed	MM163
186E	Operator Handbook	Printed	MM163
186	Kolher® M8 Engine Service Manual	Printed	38977

Keep your manuals in a safe, convenient location for your future reference in order to operate, maintain, and order repair parts for your machine. Everyone who operates, maintains, or purchases parts for the machine should have easy access to a copy of the manual.

To get pricing information or to order copies of these publications, contact your nearest Tennant Company parts warehouse, distributor, or sales representative.