



## Electronic Service Manuals

This electronic document is provided as a service to our customers. We do not create the contents of the information contained in this document. Should you have detailed questions pertaining to the information contained in this document, you may contact Michco, or the manufacturer which provided the original information in this electronic deliverable. Michco's only part in this electronic deliverable was the electronic assembly process. By providing this manual on line we are not guaranteeing parts availability.

You may contact Michco through the following methods:

Phone (517) 484-9312 or (800) 331-3339

2011 N. High St. -- Lansing, Michigan -- 48906

Fax: (517) 484-9836

Email: [CustServe@Michco.com](mailto:CustServe@Michco.com)

Web site: [www.Michco.Com](http://www.Michco.Com)

Parts Web site: [www.FloorMachineParts.Com](http://www.FloorMachineParts.Com)

Order Parts on Line at:

**[www.FloorMachineParts.Com](http://www.FloorMachineParts.Com)**

Directly to Parts & Service:

By Email: **[Shop@Michco.com](mailto:Shop@Michco.com)**

By Fax: (517) 702-2041

By Voice: Use numbers above.

**Serving the Cleaning Industry Since 1922**

Notice: All copyrighted material remains property of original owners, all trademarks are property of respective owners. Manuals are subject to Manufacturer's reproduction limitations. Originals or reproductions were provided by manufacturers through a request. We make no warranty as to the correctness of information provided in this document and you assume all risk. By placing these manuals on line we are not declaring our corporation to be an manufacturer authorized dealer or provider, please check our web site for authorized manufacturers we represent.



# S3B

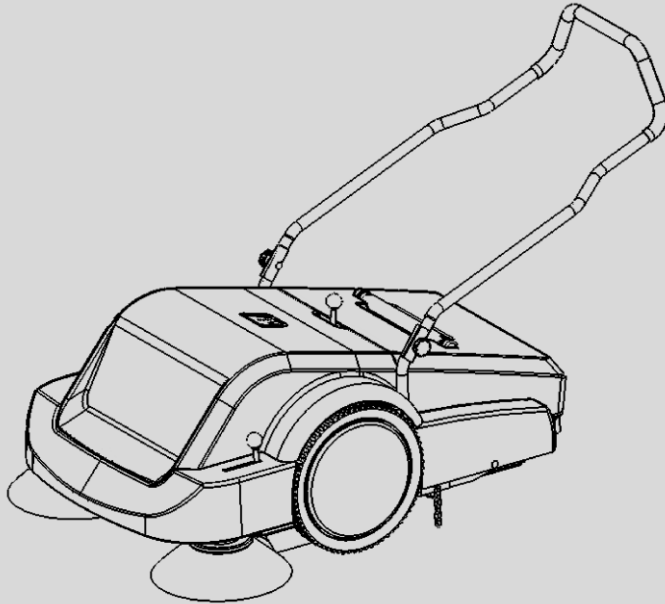

**Battery Powered Push Sweeper**

**Barredora eléctrica**

**Balayeuse autotractée alimentée  
par batterie**

**Varredora de empurrar à bateria**

**电瓶供电手推式扫地机**

Model Part No.:  
1069646 – S3B NA  
9010142 – S3B AUS / CN  
9010144 – S3B EX

**Operator and Parts Manual** (EN)

**Manual de funcionamiento  
y lista de componentes** (ES)

**Manuel de fonctionnement  
et liste des pièces** (FR)

**Manual de Instruções e de Peças** (PT)

**操作与零部件手册** (CN)

**TwinMax™ Technology**

**Tennant True® Parts**



[www.tennantco.com/manuals](http://www.tennantco.com/manuals)

**9009645**  
**Rev. 03 (11-2013)**

**Introduction**

This manual is furnished with each new model. It provides necessary operation and maintenance instructions and replacement parts information.



**Read all instructions before using this machine.**

**Intended Use**

This battery powered push sweeper is intended for commercial use, for example in buildings, warehouses, parking lots and sidewalks. It is designed for indoor and outdoor use and suitable for picking up dry, nonflammable dust and debris on dry hard floor and carpet surfaces. It is not suitable for wet surfaces or for picking up flammable or hazardous materials.

**General Information**

This machine will provide excellent service. However, the best results will be obtained at minimum costs if:

- The machine is operated with reasonable care.
- The machine is maintained regularly - per the machine maintenance instructions provided.
- The machine is maintained with manufacturer-supplied or equivalent parts.



**Protect the Environment**

Please dispose of packaging materials and used machine components in an environmentally safe way according to local waste disposal regulations.

Always remember to recycle.

**Machine Data**

Please fill out at time of installation for future reference.  
 Model No. - \_\_\_\_\_  
 Serial No. - \_\_\_\_\_  
 Installation Date - \_\_\_\_\_

**Technical Specifications**

Model	S3B
Length	1092 mm / 43 in
Width	760 mm / 30 in
Height	416 mm / 16.5 in
Weight	56 kg / 123.5 lb
Sweeping Path Width	870 mm / 34 in
Main Brush Width	500 mm / 20 in
Side Brush Diameter	320 mm / 13 in
Hopper Capacity	50 L / 53 qt
Battery Capacity	12 V, 26 Ah
Total Power Consumption	12 VDC, 430 W, 13 A
Battery Charger	100-240VAC 5A
Productivity Rate (Net)	1740 m <sup>2</sup> /hr / 18750 ft <sup>2</sup> /hr
Vibration at Controls	<2.5m/s <sup>2</sup>
Sound Pressure Level at operator ear	65 dB(A)
Protection Grade	IPX3
Operation Temperature	min. -15°C, max. 40°C

Tennant Company  
 PO Box 1452, Minneapolis, MN 55440 USA  
 Phone: (800) 553-8033 or (763) 513-2850  
 www.tennantco.com  
 Original Instructions. Copyright © 2012 TENNANT Company.  
 All rights reserved. Printed in Germany.  
 Specifications and parts are subject to change without notice.

**IMPORTANT SAFETY INSTRUCTIONS (SAVE THESE INSTRUCTIONS)**



This symbol warns the operator of hazards and unsafe practices which could result in severe personal injury or death.



**WARNING: To Reduce the Risk of Fire, Explosion, Electric Shock, or Injury:**

- Do not use near flammable liquids, vapors or combustible dusts.
- Do Not Pick Up Flammable or Toxic Materials and Burning Debris.
- Batteries Emit Hydrogen gas. Keep Sparks and Open Flame Away When Charging Batteries.
- Charge batteries in a well ventilated area.
- Disconnect Battery Cable and Charger Cord Before Servicing.
- Do Not Charge Batteries with Damaged Cord. Do Not Modify Plug.
- Do Not Use On Wet Surfaces. Store Indoors.

The following safety precautions signal potentially dangerous conditions to the operator or equipment.

**FOR SAFETY:**

1. Do not operate machine:
  - Unless trained and authorized.
  - Unless operator manual is read and understood.
  - Unless mentally and physically capable of following machine instructions.
  - In areas that are too dark to safely see the controls or operate the machine.
  - If not in proper operating condition.
  - Without hopper and/or filter in place.
2. Before operating machine:
  - Make sure all safety devices are in place and operate properly.
3. When operating machine:
  - Use only as described in manual.
  - Do not pick up objects such as cords, strings, wires that may entangle brush.
  - Report machine damage or faulty operation immediately.
  - Do not leave unattended or on an unlevel surface.
  - Do not allow children to play on or around machine.
  - Keep children and unauthorized persons away from machine when in use.
  - Go slow on slippery surfaces.
  - Do not operate on inclines that exceed 2 %.
  - Do not use machine to transport people or objects.
  - Wear a dust mask, protective glasses and gloves in dusty environments.

- Keep hands away from spinning brush.
  - Use caution when lifting full hopper to avoid back strain.
  - Wear heavy gloves when removing sharp objects from hopper.
  - Turn machine power off if brush becomes obstructed or machine malfunctions.
- 4. Before leaving or servicing machine:**
- Stop on level surface.
  - Turn machine power off.
- 5. When servicing machine:**
- Turn the main power button to the off position.
  - Disconnect battery cable and charger cord before working on machine.
  - Wear protective gloves and glasses when handling batteries or battery cables.
  - Avoid contact with battery acid.
  - Use manufacturer supplied or approved replacement parts.
  - All repairs must be performed by a qualified service person.
  - Avoid moving parts. Do not wear loose clothing or jewelry and secure long hair.
  - Do not power spray or hose off machine near electrical components.
  - Do not modify the machine from its original design.
  - All work must be done having enough visibility and/or appropriate lighting.
  - Wear personal protective equipment as needed.
- 6. When transporting machine:**
- Turn the main power switch to the off position.
  - Get assistance when lifting machine.
  - Use a loading ramp that will support the weight of the machine.
  - Do not wheel up or down stairs.
  - Use tie-down straps to secure machine when transporting by vehicle.

### Onboard Battery Charger Information

The onboard battery charger's charging profile is specifically configured for a 12V sealed AGM battery. When installing a replacement battery it is important to use the same battery type or damage to the battery and/or charger may result.

For battery charger operating instructions, refer to the battery charger manual supplied with the machine.

### Safety Label

The safety label appears on the machine in the location indicated. Replace label if missing, damaged or illegible.

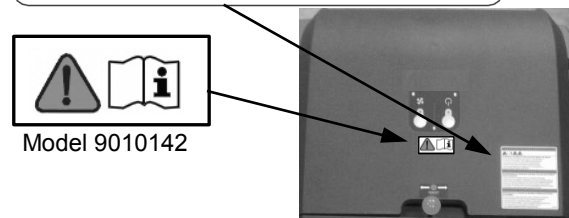

### Machine Components

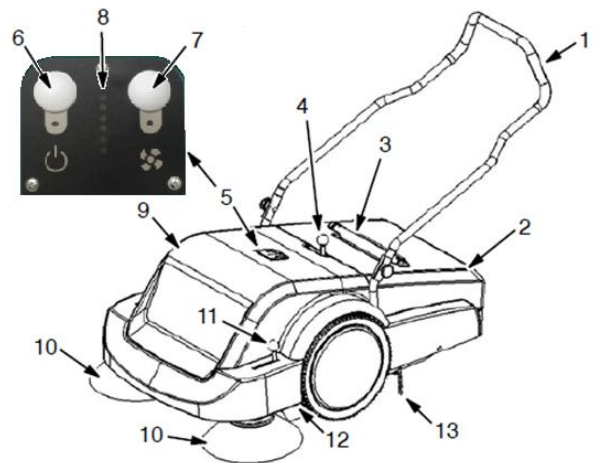

1. Detachable Control Handle
2. Debris Hopper
3. Hopper Carrying Handle
4. Dust Filter Shaker Knob
5. Control Panel
6. Main Power Button
7. Vacuum Power Button
8. Battery Discharge Indicator
9. Battery & Onboard Charger Compartment
10. Side Brush
11. Side Brush Adjustment knob
12. Dual Main Brushes
13. Anti-static Chain

## Introducción

Este manual se incluye en todos los modelos nuevos. Proporciona la información necesaria para su utilización, mantenimiento y cómo reponer las piezas.



**Lea todas las instrucciones antes de utilizar esta máquina.**

## Uso previsto

Este cortacésped manual está pensado para su uso comercial en edificios, almacenes, aparcamientos y aceras, entre otros. Está diseñado para interior y exterior y además recoge el polvo y los restos de suciedad secos y no inflamables de los suelos secos y alfombras. No es apropiado para superficies mojadas o para recoger materiales inflamables o peligrosos.

## Información general

Esta máquina ofrece un funcionamiento excelente. Sin embargo, los resultados serán óptimos a un coste mínimo si:

- Maneja la máquina con un cuidado razonable.
- Realiza las operaciones de mantenimiento regularmente y de acuerdo con las instrucciones adjuntas.
- Las operaciones de mantenimiento de la máquina se realizan con piezas suministradas por el fabricante o equivalentes.



### Proteja el medio ambiente

Deseche el material de embalaje y los componentes usados de la máquina de forma segura para el medio ambiente, de acuerdo con las normas locales sobre desecho de residuos.



No olvide reciclar.

## Datos de la máquina

Rellene esta ficha cuando realice la instalación, para utilizarla como referencia en el futuro.

Número de modelo - \_\_\_\_\_  
 Número de serie - \_\_\_\_\_  
 Fecha de instalación - \_\_\_\_\_

## Especificaciones técnicas

Modelo	S3B
Longitud	1092 mm / 43"
Anchura	760 mm / 30"
Altura	416 mm / 16.5"
Peso	56 kg / 123.5 lb
Anchura de la pista de barrido	870 mm / 34"
Anchura del cepillo principal	500 mm / 20"
Diámetro del cepillo lateral	320 mm / 13"
Capacidad de la caja colectorora	50 L / 53 cuartos
Capacidad de la batería	12 V, 26 Ah
Consumo total de energía	12 VDC, 430 W, 13 A
Cargador de baterías	100-240VAC 5A
Productividad media (neta)	1740 m <sup>2</sup> /hr / 18.750 pies <sup>2</sup> /hr
Vibración en controles	<2,5 m/s <sup>2</sup>
Nivel de ruido en el oído del operador	65 dB(A)
Índice de protección	IPX3
temperatura de operación	min. -15°C, max. 40°C

Tennant Company  
 PO Box 1452, Minneapolis, MN 55440 USA  
 Teléfono: 001-800-553-8033 o 001-763- 513-2850  
 www.tennantco.com

Instrucciones originales. Copyright © 2012 TENNANT Company.  
 Todos los derechos reservados. Impreso en Alemania.  
 Las características técnicas y las piezas están sujetas a modificaciones sin previo aviso.

## MEDIDAS DE SEGURIDAD (GUARDE ESTAS INSTRUCCIONES)



Este símbolo advierte al operario de los riesgos y hábitos peligrosos que podrían causar lesiones corporales graves o mortales.



**ADVERTENCIA:** para reducir el riesgo de incendios, explosiones, descargas eléctricas o lesiones:

- No utilice la máquina cerca de líquidos, polvos o vapores inflamables.

Esta máquina no está equipada con motores a prueba de explosiones. Los motores eléctricos producirán chispas tanto durante el arranque como durante su utilización que pueden provocar incendios o explosiones si utiliza la máquina en presencia de líquidos o vapores inflamables o partículas combustibles.

- No recoja materiales tóxicos o inflamables ni residuos humeantes o ardiendo.
- Las baterías emiten hidrógeno. Mantenga brasas o fuego alejados cuando cargue las baterías.
- Cargue siempre las baterías en un lugar bien ventilado.
- Desconecte los cables de batería y el enchufe del cargador antes de realizar operaciones de mantenimiento en la máquina.
- No cargue las baterías si el cable está dañado. No modifique el enchufe.
- No utilice la máquina sobre superficies mojadas. Guárdela en un lugar cerrado.

Las siguientes medidas de seguridad hacen referencia a situaciones potencialmente peligrosas para el operario o el equipo.

### SEGURIDAD:

1. No utilice la máquina:
  - A no ser que cuente con la formación y autorización adecuada.
  - A no ser que haya leído y comprendido el manual del operario.
  - A no ser que tenga la capacidad física y mental para seguir las instrucciones de la máquina.
  - En lugares demasiado oscuros para ver los controles o utilizar la máquina con seguridad.
  - Si la máquina no funciona correctamente.
  - Sin haber colocado los filtros y/o la caja recolectora.
2. Antes de utilizar la máquina:
  - Asegúrese de que todos los dispositivos de seguridad están bien instalados y funcionan correctamente.
3. Al utilizar la máquina:
  - Utilice la máquina solamente como se describe en el manual.
  - No recoja objetos como cuerdas, hilos o cables que pudieran enredar el cepillo.
  - Informe inmediatamente de las averías de la máquina o de si el funcionamiento no es correcto.
  - Vigile la máquina en todo momento y no la deje en una superficie inestable.
  - No permita que los niños jueguen encima o alrededor de la máquina.
  - Mantenga a los niños y a las personas no autorizadas alejados de la máquina mientras esté en uso.
  - Vaya despacio en superficies resbaladizas.
  - No utilice la máquina en superficies inclinadas que excedan el 2%.
  - No utilice la máquina para transportar personas u objetos.
  - En ambientes con mucho polvo, protéjase con una mascarilla contra el polvo, gafas y guantes.

- Cepillo giratorio. Mantenga alejadas las manos
- Sea precavido cuando levante la caja colectorora llena para evitar dolores de espalda.
- Protéjase con guantes cuando retire objetos punzantes del filtro.
- Apague la máquina si no está funcionando correctamente o si el cepillo se bloquea.

#### 4. Antes de dejar la máquina o realizar operaciones de mantenimiento:

- Detenga la máquina en una superficie plana.
- Apague la máquina.

#### 5. Cuando realice operaciones de mantenimiento:

- Sitúe el interruptor principal en la posición de apagado.
- Desconecte el cable de la batería y el del cargador antes realizar las operaciones de mantenimiento.
- Utilice guantes y gafas de protección al trabajar con las baterías o sus cables.
- Evite el contacto con el ácido de las baterías.
- Utilice repuestos suministrados o aprobados por el fabricante.
- Todas las reparaciones debe realizarlas personal técnico cualificado.
- Evite las partes en movimiento. No lleve prendas sueltas ni joyas y recójase el pelo si lo tiene largo.
- No moje la máquina rociándola o utilizando una manguera cuando esté cerca de componentes eléctricos.
- No modifique el diseño original de la máquina.
- Todos los trabajos deben realizarse con visibilidad suficiente e iluminación adecuada.
- Protéjase llevando las prendas o equipo adecuados.

#### 6. Al transportar la máquina:

- Sitúe el interruptor principal en la posición de apagado.
- Pida ayuda para levantar la máquina.
- Utilice una rampa de carga capaz de soportar el peso de la máquina.
- No baje ni suba escaleras utilizando las ruedas de la máquina.
- Utilice las correas de sujeción para fijar la máquina cuando la transporte en un vehículo.

### Información sobre el cargador de batería integrado

El tipo de carga que realiza el cargador de batería integrado está específicamente configurado para cargar una batería sellada AGM de 12V. Cuando se cambia la batería, es importante utilizar el mismo tipo de batería. En caso contrario la batería o el cargador podrían resultar dañados.

Para las instrucciones de uso del cargador, consulte el manual del cargador de batería que se incluye con la máquina.

### Adhesivo de seguridad

El adhesivo de seguridad se encuentra en la posición indicada a continuación. Sustituya el adhesivo si se ha perdido, está deteriorado o es ilegible.

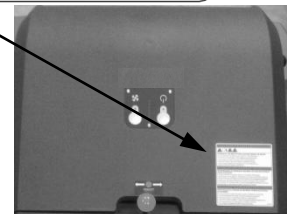

### Componentes de la máquina

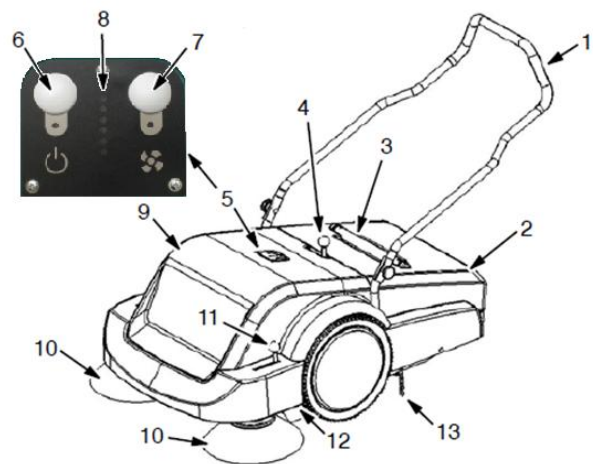

1. Manillar de control desmontable
2. Caja colectorora de desperdicios
3. Asa para transportar la caja colectorora
4. Tirador para agitar el filtro de polvo
5. Panel de control
6. Botón de encendido principal
7. Botón de encendido del aspirador
8. Indicador del nivel de carga de la batería
9. Compartimento de la batería y del cargador integrado
10. Cepillo lateral
11. Tirador de ajuste del cepillo lateral
12. Cepillos principales dobles
13. Cadena anti-estática

## Introduction

Ce manuel accompagne chaque nouveau modèle. Il fournit les instructions nécessaires au fonctionnement et à l'entretien, ainsi que les informations relatives au remplacement des pièces.



**Lisez toutes les instructions avant d'utiliser cette machine.**

## Utilisation prévue

Cette balayeuse autotractée alimentée par batterie est destinée à un usage commercial (par exemple, dans les bâtiments, entrepôts, parcs de stationnement et trottoirs). Elle peut être utilisée à l'intérieur et à l'extérieur, et permet de ramasser la poussière sèche et non-inflammable, ainsi que les déchets sur sol dur et sec et les surfaces des moquettes. Elle ne peut pas être utilisée sur des surfaces humides ou pour le ramassage de matériaux inflammables ou toxiques.

## Informations générales

Cette machine fournit d'excellents services. Toutefois, vous obtiendrez les meilleurs résultats, à moindre coût, si :

- La machine doit être manipulée avec précaution.
- La machine fait l'objet d'un entretien régulier, conformément aux instructions d'entretien fournies.
- L'entretien de la machine s'effectue avec les pièces fournies par le fabricant ou des pièces équivalentes.



### Protection de l'environnement

Pour éliminer les matériaux d'emballage et les composants usagés de la machine en respectant l'environnement, respectez les réglementations locales en vigueur concernant la mise au rebut des déchets.

Pensez toujours à recycler.

## Données de la machine

À remplir au moment de l'installation pour s'y référer ultérieurement.

N° de modèle - \_\_\_\_\_

N° de série - \_\_\_\_\_

Date d'installation - \_\_\_\_\_

## Caractéristiques techniques

Modèle	S3B
Longueur	1092 mm / 43 in
Largeur	760 mm / 30 in
Hauteur	416 mm / 16.5 in
Poids	56 kg / 123.5 lb
Largeur de la trace de balayage	870 mm / 34 in
Largeur de la brosse principale	500 mm / 20 in
Diamètre de la brosse latérale	320 mm / 13 in
Capacité du bac à déchets	50 L / 53 qt
Capacité de la batterie	12 V, 26 Ah
Consommation électrique totale	12 VDC, 430 W, 13 A
Chargeur de la batterie	100-240 V CA, 5 A
Taux de rendement (net)	1 740 m <sup>2</sup> /h / 18 750 ft <sup>2</sup> /h
Vibrations au niveau des commandes	<2,5 m/s <sup>2</sup>
Niveau de pression acoustique au niveau de l'oreille de l'opérateur	65 dB(A)
Degré de protection	IPX3
température de fonctionnement	min. -15°C, max. 40°C

Tennant Company  
PO Box 1452, Minneapolis, MN 55440 États-Unis d'Amérique  
Téléphone : (800) 553-8033 ou (763) 513-2850

www.tennantco.com

Instructions d'origine. Copyright © 2012 TENNANT Company.

Tous droits réservés. Imprimé en Allemagne.

Les caractéristiques et les pièces sont susceptibles d'être modifiées sans avis préalable.

## CONSIGNES DE SÉCURITÉ IMPORTANTES (CONSERVEZ CES INSTRUCTIONS)



Ce symbole avertit l'opérateur de situations à risque ou de pratiques dangereuses pouvant provoquer des blessures graves, voire mortelles.



**AVERTISSEMENT : Afin de réduire le risque d'incendie, d'explosion, de choc électrique ou de blessure :**

- **N'utilisez pas la machine à proximité de liquides ou de vapeurs inflammable, ni de poussières combustibles.**

**La machine n'est pas équipée de moteurs protégés contre les explosions. Les moteurs électriques génèrent des étincelles au moment du démarrage et pendant leur fonctionnement, ce qui peut entraîner un incendie instantané ou une explosion si la machine est utilisée dans une zone où des vapeurs/liquides inflammables ou des poussières combustibles sont présents.**

- **Ne ramassez pas de matériaux inflammables ou toxiques, ni de déchets incandescents.**
- **Les batteries émettent du gaz hydrogène. Éloignez les sources d'étincelles ou de flammes ouvertes lors du chargement des batteries.**
- **Rechargez les batteries dans un endroit bien aéré.**
- **Débranchez les câbles de la batterie et le cordon du chargeur avant l'entretien.**
- **Ne chargez pas la batterie avec un cordon endommagé. Ne modifiez pas la prise.**
- **N'utilisez pas la machine sur des surfaces humides. Entrez la machine à l'intérieur.**

Les consignes de sécurité mentionnées ci-après indiquent les situations présentant un danger pour l'opérateur ou l'équipement.

### POUR VOTRE SÉCURITÉ :

#### 1. N'utilisez pas la machine :

- Si vous n'y êtes pas formé et autorisé.
- Avant d'avoir lu et compris le manuel d'utilisation.
- Si nous n'êtes pas mentalement et physiquement capable de suivre les instructions d'utilisation de la machine.
- Dans les endroits trop sombres pour pouvoir distinguer les commandes de la machine ou l'utiliser en toute sécurité.
- Si elle n'est pas en bon état de marche.
- Sans bac à déchets et/ou filtre en place.

#### 2. Avant de mettre la machine en marche :

- Assurez-vous que tous les dispositifs de sécurité sont en place et fonctionnent correctement.

#### 3. Lors de l'utilisation de la machine :

- Utilisez la machine uniquement tel qu'indiqué dans ce manuel.
- Ne ramassez pas d'objets susceptibles de se coincer dans la brosse (tel que des cordes, ficelles ou fils).
- Signalez immédiatement tout dommage ou dysfonctionnement.
- Ne laissez jamais la machine sans surveillance ou sur une surface non plane.
- Empêchez les enfants de jouer à proximité de la machine.
- Maintenez les enfants et les personnes non autorisées à l'écart de la machine pendant son utilisation.
- Roulez lentement sur les surfaces glissantes.
- N'utilisez pas la machine sur des pentes dépassant 2 %.
- N'utilisez pas la machine pour transporter des personnes ou des objets.
- Portez un masque antipoussière, des lunettes protectrices et des gants dans les environnements poussiéreux.

- Brosse en rotation. Éloignez vos mains.
  - Lors du levage des bacs à déchets pleins, faites attention à ne pas vous faire un tour de reins.
  - Portez des gants renforcés pour ramasser les objets tranchants des bacs à déchets.
  - Mettez la machine hors tension si la brosse se coince ou la machine ne fonctionne pas correctement.
4. Avant de quitter la machine ou d'en effectuer l'entretien :
- Arrêtez-la sur une surface plane.
  - Mettez la machine hors tension.
5. Lors de l'entretien de la machine :
- Placez le commutateur principal en position OFF.
  - Débranchez le câble de la batterie et la prise du chargeur avant de travailler sur la machine.
  - Portez des gants et des lunettes de protection lorsque vous manipulez les batteries ou les câbles de batterie.
  - Évitez tout contact avec l'acide des batteries.
  - Utilisez des pièces de rechanges fournies ou approuvées par le fabricant.
  - Toutes les réparations doivent être effectuées uniquement par un technicien qualifié.
  - Évitez les pièces mobiles. Ne portez pas de vêtements amples et attachez vos cheveux s'ils sont longs.
  - N'utilisez pas de jet ou de tuyau de pression à proximité des composants électriques de la machine.
  - Ne modifiez pas la conception d'origine de la machine.
  - Tous les travaux doivent être exécutés avec une visibilité suffisante et/ou un éclairage approprié.
  - Portez un équipement de protection approprié.
6. Lors du transport de la machine :
- Placez le commutateur principal en position OFF.
  - Demandez de l'aide pour soulever la machine.
  - Utilisez une rampe de chargement capable de supporter le poids de la machine.
  - Ne faites pas rouler la machine dans les escaliers.
  - En cas de transport par véhicule, arrimez la machine avec des sangles.

### Informations concernant le chargeur de batterie embarqué

Le profil du chargeur de batterie embarqué est spécialement conçu pour une batterie AGM scellée de 12 V. Lors de l'installation ou du remplacement d'une batterie, il est important d'utiliser une batterie du même type, sans quoi, la batterie et/ou le chargeur peuvent être endommagés.

Pour les instructions de fonctionnement du chargeur de batterie, reportez-vous au manuel fourni avec la machine.

### Étiquette de mise en garde

L'étiquette de mise en garde se trouve sur la machine à l'emplacement indiqué. Remplacez toute étiquette manquante, endommagée ou devenue illisible.

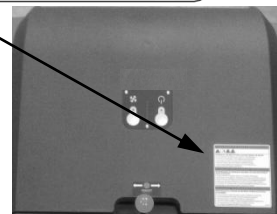

### Composants de la machine

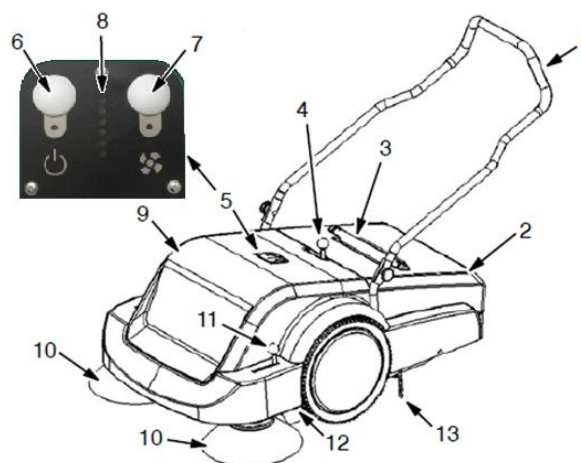

1. Poignée de commande amovible
2. Bac à déchets
3. Poignée de transport du bac à déchets
4. Bouton de secouage de filtre antipoussière
5. Tableau de bord
6. Bouton d'alimentation principale
7. Bouton d'activation de l'aspirateur
8. Indicateur de niveau de charge de la batterie
9. Compartiment de la batterie et du chargeur embarqué
10. Brosse latérale
11. Bouton de réglage de brosse latérale
12. Brosses latérales doubles
13. Chaîne antistatique

## Introdução

Este manual é distribuído com os modelos novos. Ele fornece as instruções necessárias para operação e manutenção e para substituição de peças.



**Leia todas as instruções antes de utilizar esta máquina.**

## Finalidade

A finalidade desta vassoura de empurrar à bateria é o uso comercial, por exemplo, em prédios, armazéns, estacionamentos e calçadas. Ela foi projetada para uso em espaços internos e externos e é adequada para retirar poeira e detritos secos e não-inflamáveis em piso duro seco e superfícies de carpete. Ela não é adequada para superfícies molhadas ou para retirar material inflamável ou perigoso.

## Informações gerais

Esta máquina deverá funcionar muito bem. Entretanto, serão obtidos melhores resultados com o mínimo de custos se:

- A máquina for operada com o devido cuidado.
- Houver manutenção regular da máquina; de acordo com as instruções de manutenção fornecidas.
- Houver manutenção da máquina com peças fornecidas pelo fabricante ou peças similares autorizadas.



### Proteja o meio ambiente

Descarte o material da embalagem e os componentes usados da máquina de maneira ambientalmente segura de acordo com a regulamentação local de descarte de resíduos.



Lembre-se sempre de reciclar.

## Dados da máquina

Preencha estes dados durante a instalação para referência futura.

Nº do Modelo - \_\_\_\_\_

Nº de Série - \_\_\_\_\_

Data de Instalação - \_\_\_\_\_

## Especificações técnicas

Modelo	S3B
Comprimento	1092 mm / 43 pol
Largura	760 mm / 30 pol
Altura	416 mm / 16.5 pol
Peso	56 kg / 123.5 lb
Largura do caminho de varredura	870 mm / 34 pol
Largura da escova principal	500 mm / 20 pol
Diâmetro da escova lateral	320 mm / 13 pol
Capacidade da caçamba	50 L / 53 qt
Capacidade da bateria 12V,	12 V, 26 Ah
Consumo total de energia	12 VDC, 430 W, 13 A
Carregador de bateria	100-240VAC 5A
Taxa de produtividade (Liq.)	1.740 m <sup>2</sup> /hr / 18.750 pés <sup>2</sup> /hr
Vibrações nos controles	<2,5m/s <sup>2</sup>
Nível da Pressão Sonora no Assento do Operador	65 dB(A)
Grau de proteção	IPX3
temperatura de operação	min. -15°C, max. 40°C

Tennant Company  
 Caixa Postal 1452, Minneapolis, MN 55440 EUA  
 Telefone: (800) 553-8033 ou (763) 513-2850  
 www.tennantco.com  
 Instruções originais. Copyright © 2012 TENNANT Company.  
 Todos os direitos reservados. Impresso na Alemanha.  
 Especificações e peças sujeitas a alterações sem aviso prévio.

## INSTRUÇÕES DE SEGURANÇA IMPORTANTES (GUARDE ESTAS INSTRUÇÕES)



Este símbolo adverte o operador dos perigos e práticas perigosas que podem causar ferimentos graves ou morte.



**AVISO:** Para reduzir o risco de incêndio, explosão, choque elétrico ou ferimento:

- Não use próximo a líquidos ou vapores inflamáveis ou pós combustíveis.

Esta máquina não está equipada com motores à prova de explosão. Os motores elétricos soltarão faíscas ao serem ligados e durante a operação, o que pode causar chamas ou explosão se a máquina for usada em um local onde estejam presentes vapores/líquidos inflamáveis ou pós combustíveis.

- Não faça a coleta de material inflamável ou tóxico e de detritos em chamas.
- As baterias emitem gás de hidrogênio. Mantenha as faíscas e as chamas abertas distantes ao recarregar as baterias.
- Recarregue as baterias em uma área bem ventilada.
- Desconecte os cabos da bateria e a tomada do carregador antes de fazer a manutenção da máquina.
- Não recarregue baterias se o cabo de alimentação estiver danificado. Não modifique o plugue.
- Não utilizar em superfícies molhadas. Armazene em um local fechado.

Os símbolos de precaução de segurança a seguir alertam quanto a possíveis condições de risco para o operador ou equipamento.

### MEDIDA DE SEGURANÇA:

1. Não opere a máquina:
  - A menos que tenha sido treinado e autorizado.
  - A menos que tenha lido e compreendido o Manual de Operação.
  - A menos que seja mentalmente e fisicamente capaz de seguir as instruções da máquina.
  - Em áreas em que a escuridão impede de ver os controles ou operar a máquina.
  - Se ela não estiver em condições apropriadas de operação.
  - Sem que a caçamba e/ou o filtro esteja no lugar.
2. Antes de operar a máquina:
  - Certifique-se de que todos os dispositivos de segurança estão na posição correta e operando apropriadamente.
3. Ao operar a máquina:
  - Utilize somente conforme a descrição deste manual.
  - Não faça a coleta de objetos como cordas, fitas e cabos que podem embolar na escova.
  - Notifique imediatamente qualquer dano na máquina ou falha na operação.
  - Não deixe sem supervisão ou em superfície desnivelada.
  - Mantenha distante de crianças.
  - Mantenha crianças ou pessoas não autorizadas distantes da máquina quando ela estiver sendo usada.
  - Desloque-se lentamente em superfícies escorregadias.
  - Não opere a máquina em declives maiores do que 2%.
  - Não utilize a máquina para transportar pessoas ou objetos.
  - Use uma máscara contra poeira, óculos protetores e luvas em ambientes empoeirados.

- Escova rotativa. Mantenha longe do alcance das mãos.
- Tenha cuidado ao levantar a caçamba para evitar machucar as costas.
- Use luvas pesadas ao remover objetos pontiagudos do caçamba.
- Desligue a máquina se a escova for obstruída ou se a máquina tiver um defeito.

#### 4. Antes de deixar a máquina ou de fazer a manutenção:

- Pare em uma superfície plana.
- Desligue a máquina.

#### 5. Ao fazer a manutenção da máquina:

- Gire o interruptor principal para a posição desligado.
- Desconecte o cabo da bateria e a tomada do carregador antes de fazer a manutenção da máquina.
- Use luvas protetoras e óculos ao manusear baterias ou cabos de baterias.
- Evite o contato com as substâncias ácidas da bateria.
- Use somente peças fornecidas pela TENNANT ou peças similares.
- Todos os consertos devem ser feitos por uma equipe de serviços qualificada.
- Evite peças móveis. Não use roupas largas nem joias e proteja cabelos longos.
- Não utilize jatos de água sob pressão ou qualquer jato de água próximo de componentes elétricos.
- Não modifique o design original da máquina.
- Todo o trabalho deve ser realizado com visibilidade suficiente e/ou iluminação adequada.
- Use equipamento de proteção pessoal, conforme necessário.

#### 6. Ao transportar a máquina:

- Gire o interruptor principal para a posição desligado.
- Peça assistência para levantar a máquina.
- Use um guindaste ou macaco que suporte o peso da máquina.
- Não role a máquina escada acima ou abaixo.
- Utilize tiras de amarrar para proteger a máquina quando transportada por um veículo.

### Informações sobre o carregador a bordo

O perfil de carregamento do carregador da bateria a bordo é especificamente configurado para uma bateria AGM de 12 V selada. Ao instalar uma bateria de substituição, é importante utilizar o mesmo tipo de bateria ou poderá haver dano à bateria e/ou ao carregador.

Para obter instruções operacionais do carregador da bateria, consulte o manual do carregador de bateria fornecido com a máquina.

### Adesivo de segurança

O adesivo de segurança aparece na máquina no local indicado. Substitua o adesivo caso esteja faltando ou esteja danificado ou ilegível.

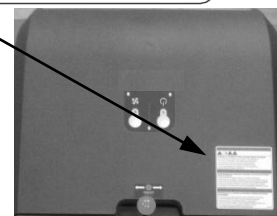

### Componentes da máquina

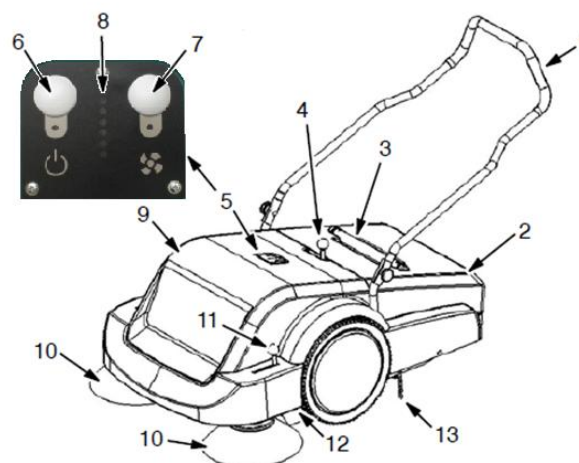

1. Alça de controle destacável
2. Caçamba de detritos
3. Alça para carregar a caçamba
4. Maçaneta da bateadeira do filtro de poeira
5. Painel de controle
6. Botão de energia principal
7. Botão de energia do aspirador
8. Indicador de descarga da bateria
9. Compartimento do carregador da bateria e a bordo
10. Escova lateral
11. Maçaneta de ajuste da escova lateral
12. Escovas principais duplas
13. Cadeia anti-estática

## 引言

本手册随每种新机型提供，它提供必要的操作、维护说明和更换部件信息。



**使用本机器前请阅读所有说明**

## 用途

这款电瓶供电手推式扫地机用于商业用途，例如建筑物、仓库、停车场和人行道。它针对室内和室外应用设计，适合拾取干硬地面和地毯表面上的不易燃干燥粉尘和碎屑。它不适合湿表面或拾取易燃或危险物质。

## 常规信息

本机器性能优异。但是，只有在以下情况下才能以最低成本发挥最佳性能：

- 操作机器时谨慎小心。
- 按照提供的机器维护说明定期维护机器。
- 使用制造商提供的或同等部件维护机器。



## 保护环境

请按照当地废物处理法规以环保的方式处理包装材料 and 旧的机器组件。



始终记住尽量将物品回收利用。

## 机器数据

请在安装时填写，供以后参考。	
型号 -	_____
序列号 -	_____
安装日期 -	_____

## 技术规格

型号	S3B
长度	1,092 毫米 / 43 英寸
宽度	760 毫米 / 30 英寸
高度	416 毫米 / 16.5 英寸
重量	56 千克 / 123.5 磅
扫地宽度	870 毫米 / 34 英寸
主刷宽度	500 毫米 / 20 英寸
边刷直径	320 毫米 / 13 英寸
垃圾斗容量	50 升 / 53 夸脱
电瓶容量	12 V, 26 Ah
总功耗	12 VDC, 430 W, 13 A
电瓶充电器	100-240VAC 5A
清扫效率 (净)	1,740 m <sup>2</sup> /hr / 18,750 ft <sup>2</sup> /hr
控制下的振动	<2.5m/s <sup>2</sup>
操作员耳部的声压级别	65 dB(A)
防护等级	IPX3
工作温度	-15°C 对 40°C

坦能清洁系统设备 (上海) 有限公司  
中国上海青浦漕盈路3777号1幢 201712  
电话：86 21 6922 5333

www.tennantco.com.cn

原稿说明。版权所有 © 2012 TENNANT Company.

保留所有权利。德国印刷。

规格和部件可能更改，恕不另行通知。

## 重要的安全说明

(妥善保存这些说明)



此符号警告可能导致严重人身伤害或死亡的危险和不安全做法。



**警告：**为了减少起火、爆炸、触电或受伤危险：

- 不要在靠近可燃液体、蒸气或易燃粉尘的地方使用。
- 本机器不配备防爆马达。马达在启动和工作期间会产生火花，如果在存在可燃蒸气/液体或易燃粉尘的区域使用机器，可能导致闪火或爆炸。
- 不要拾取可燃或有毒物质，以及正在燃烧的残渣。
- 电瓶会排放氢气。为电瓶充电时远离火花和明火。
- 请在通风良好的区域为电瓶充电。
- 在维修机器前断开电瓶缆线和充电线缆。
- 不要用损坏的电源线为电瓶充电。不要改装插头。
- 不要在湿表面上使用。室内存放。

以下安全预防措施表明可能会发生对操作员或设备产生危险的情况。

出于安全考虑：

1. 在以下情况下，不要操作机器：

- 未经培训和授权。
- 未阅读并理解操作员手册。
- 不能在思想上和行动上遵守机器指南。
- 所在的区域太暗，以致无法看清控制装置或安全地操作机器。
- 如果不在正确的工作状态。
- 垃圾斗和/或过滤器不在原位。

2. 操作机器前：

- 确保所有安全设备就位并且正常工作。

3. 操作机器时：

- 仅按照手册中的说明使用。
- 不要拾取可能会缠住刷子的绳索、线丝、金属丝等物体。
- 立刻报告机器损坏或故障操作。
- 不要让机器无人看管或将机器停放在不平整的表面上。
- 不允许儿童在机器上或附近玩耍。
- 不要让儿童和未经授权的人员靠近使用中的机器。
- 在光滑表面上慢行。
- 不要在超过 2% 的斜坡上操作。
- 不要使用机器运送人员或物体。
- 在多灰环境中配戴面罩、护目镜和手套。

- 旋转刷。保持手离开。
- 搬抬装满的垃圾斗时要小心，避免腰背劳损。
- 清除垃圾斗中的尖锐物体时戴上厚手套。
- 如果刷子堵塞或机器发生故障，关闭机器电源。

**4. 离开或维修机器前：**

- 在水平表面上停放。
- 关闭机器电源。

**5. 维修机器时：**

- 将电源总开关转到关闭位置。
- 在维修机器前断开电瓶线和充电线缆。
- 处理电瓶或电瓶线缆时佩戴手套和护目镜。
- 避免接触电瓶酸液。
- 使用制造商提供的或批准的更换部件。
- 所有维修工作必须由合格维修人员执行。
- 避开移动部件。不要穿着宽松的衣服或佩戴首饰并扎紧长发。
- 不要用电动喷雾器喷洒或用水管冲洗机器的电气元件附近区域。
- 不要对机器做出任何不同于原始设计的修改。
- 所有工作必须在有足够可见度和/或适当照明的情况下完成。
- 根据需要穿戴个人防护设备。

**6. 运输机器时：**

- 将电源总开关转到关闭位置。
- 提升机器时寻求帮助。
- 使用能够支撑机器重量的装载坡台。
- 不可使用轮子上下楼梯。
- 在使用车辆运输机器时应使用皮带固定机器。

**内置电瓶充电器信息**

内置电瓶充电器的充电特性专门针对 12V 密封式 AGM 电瓶配置。在安装更换电瓶时，务必使用相同的电瓶类型，否则可能损坏电瓶和/或充电器。

有关电瓶充电器的操作说明，请参阅机器随附的电瓶充电器手册。

**安全标签**

安全标签出现在机器上指示的位置中。如果标签缺失、损坏或难以辨认，请更换。

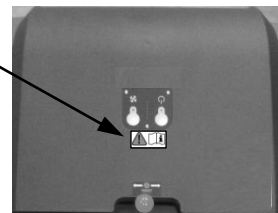

**机器组件**

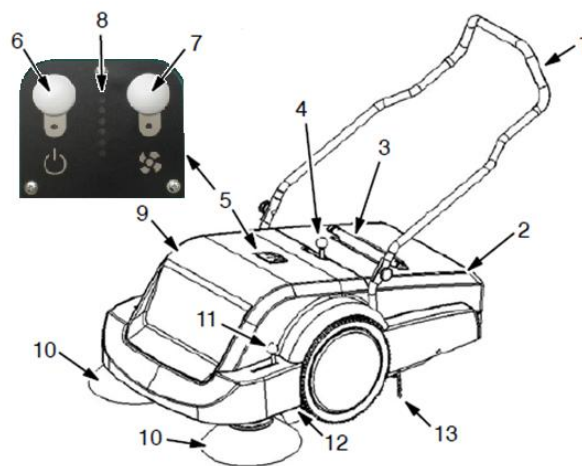

1. 可拆卸控制把手
2. 垃圾斗
3. 垃圾斗搬运手柄
4. 灰尘过滤网振动器旋钮
5. 控制面板
6. 总电源按钮
7. 真空吸尘器电源按钮
8. 电瓶放电指示灯
9. 电瓶和内置充电器舱
10. 边刷
11. 边刷调整旋钮
12. 双主刷
13. 防静电链

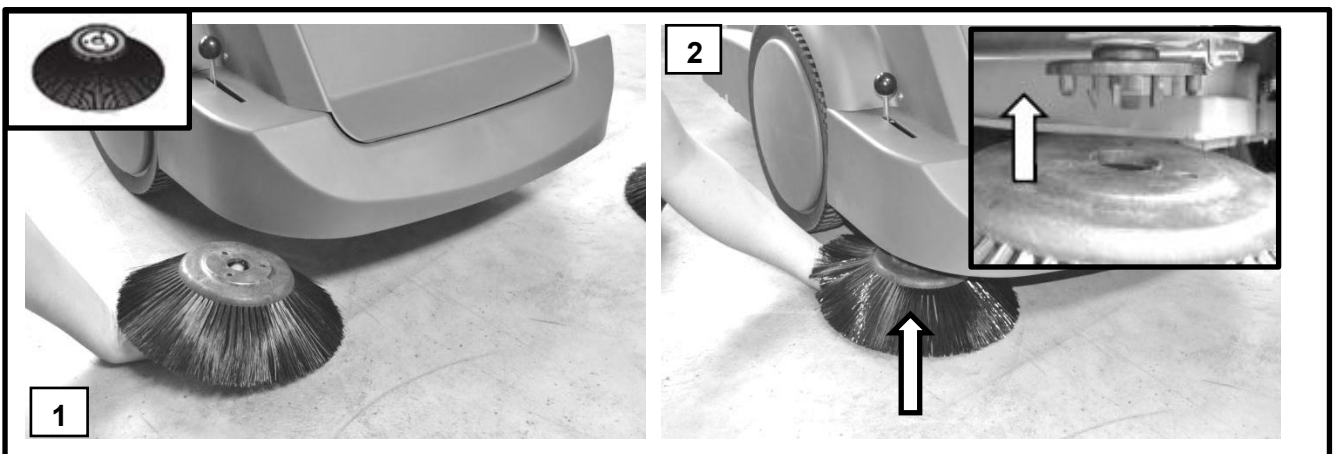
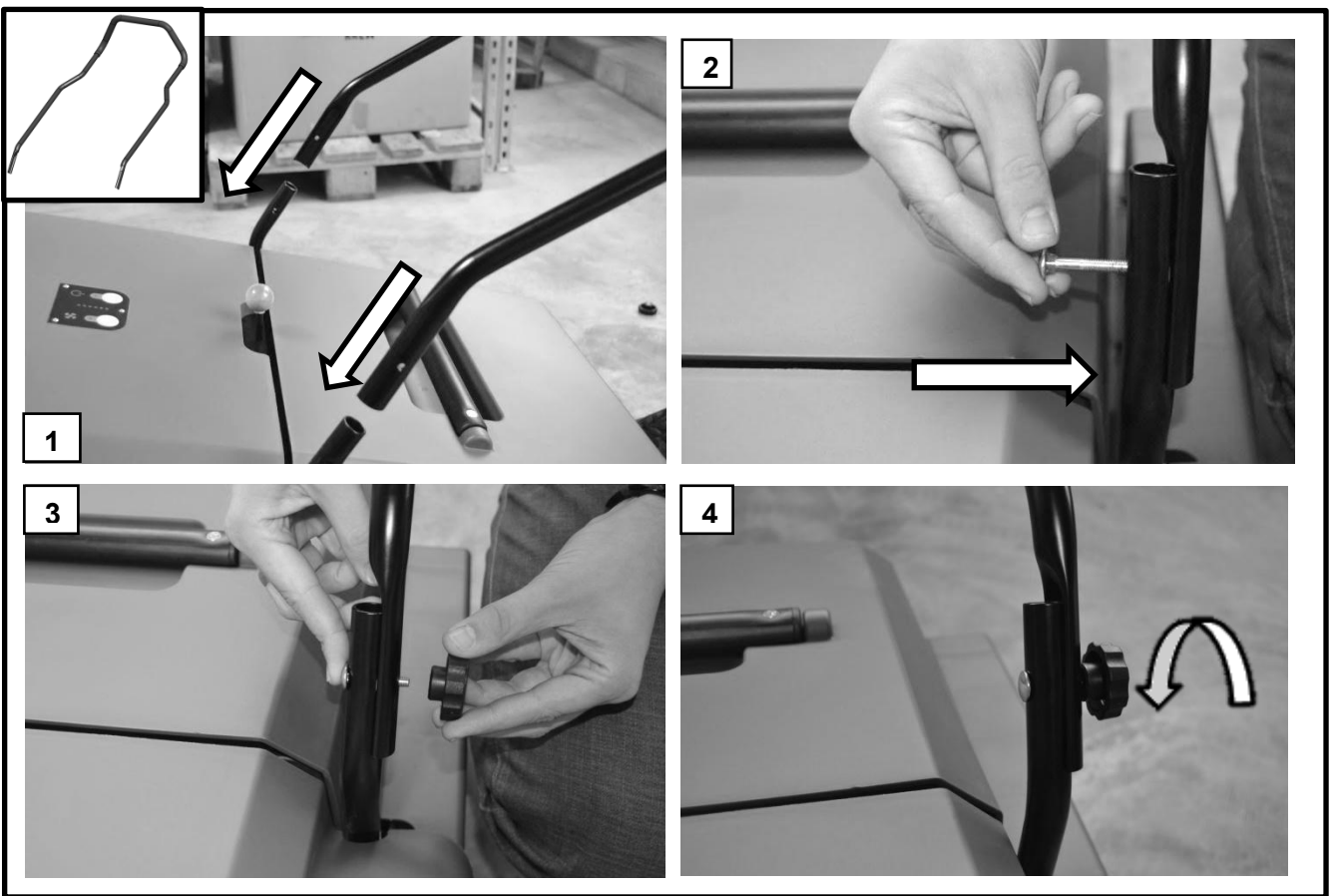
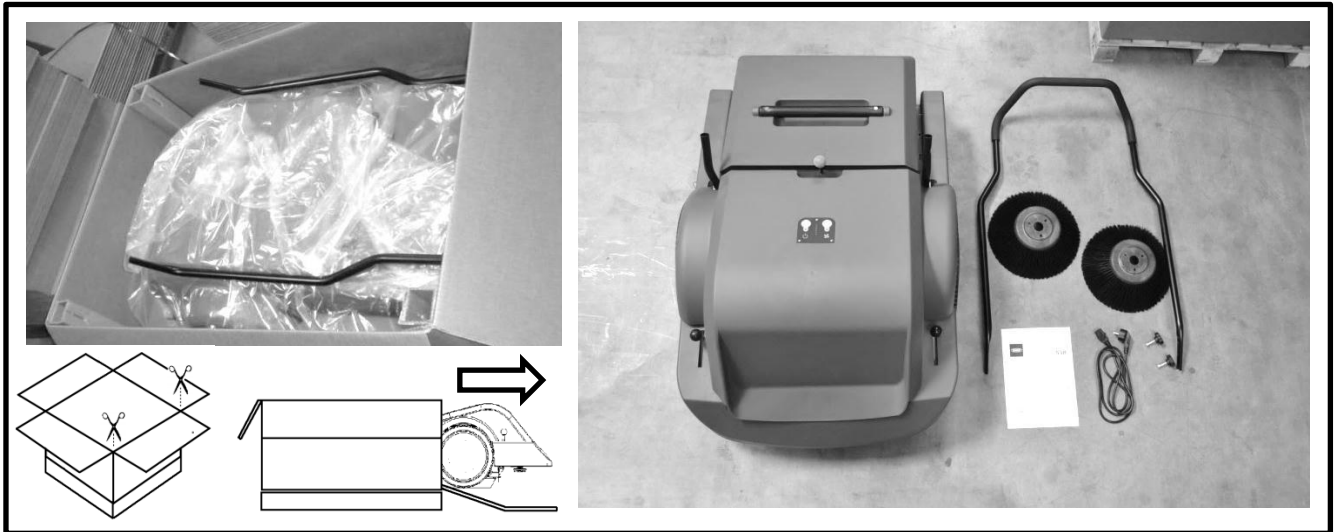

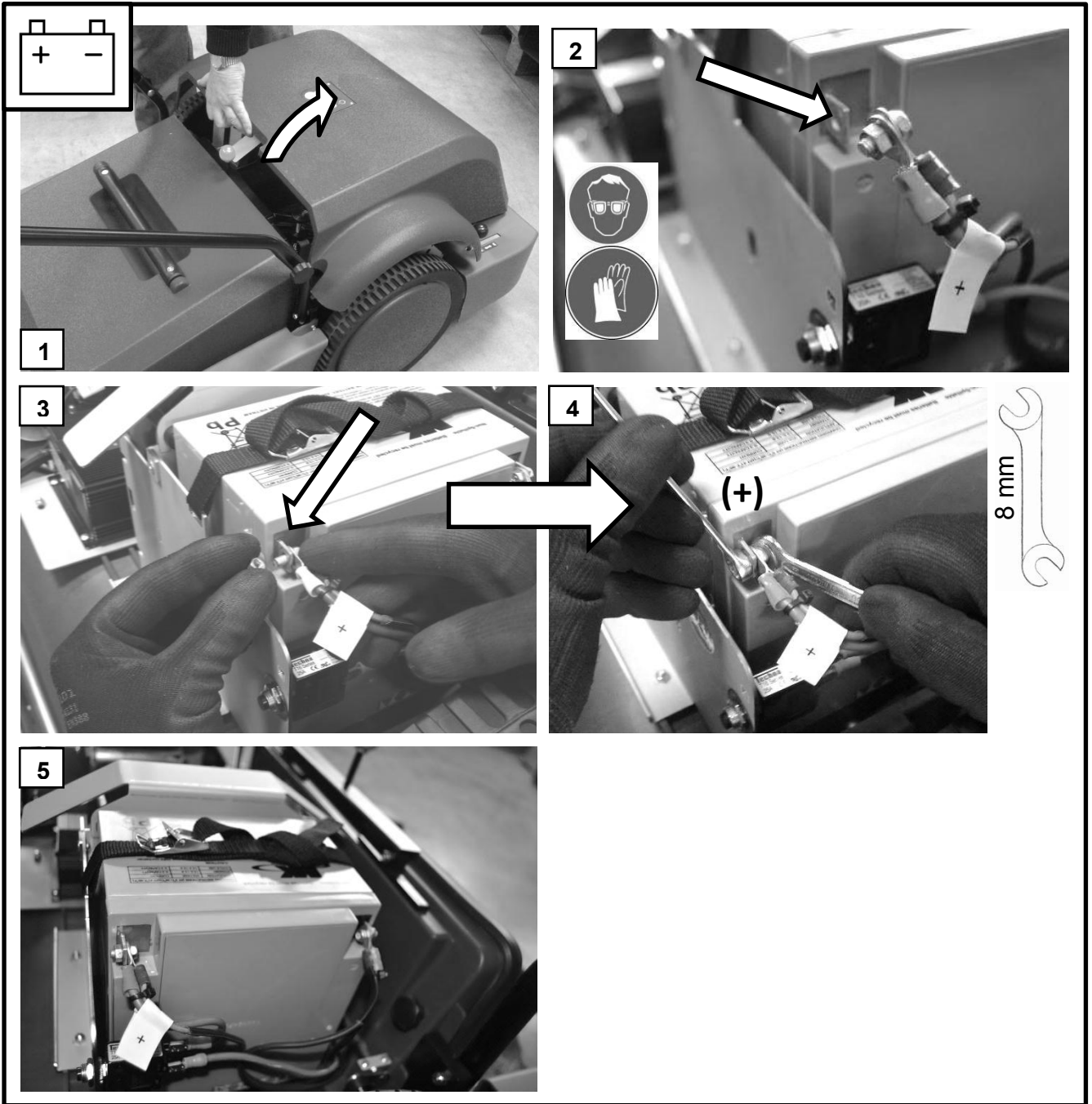

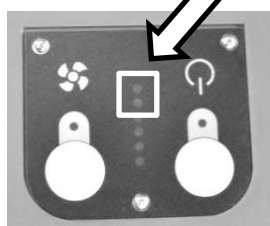
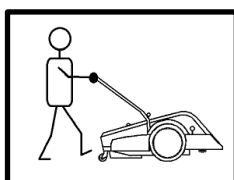
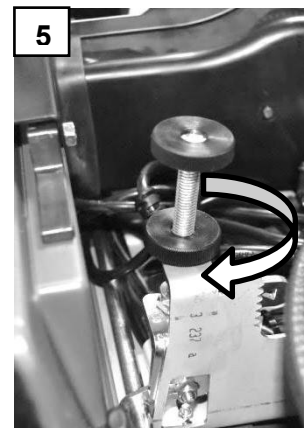
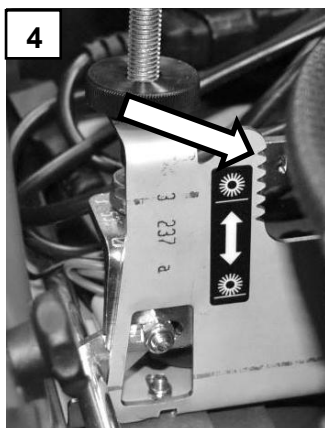
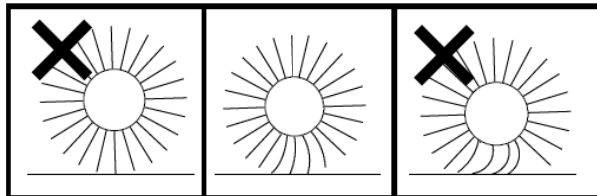
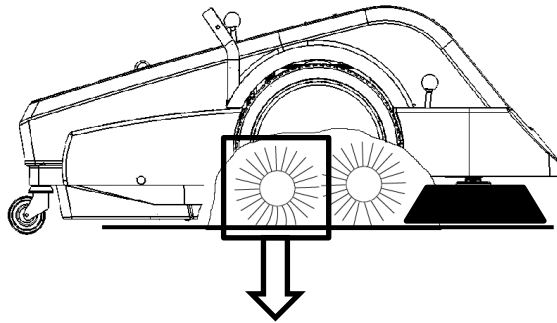
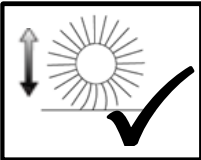

„FLASHING“

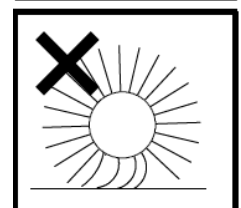
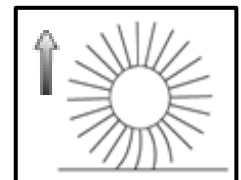
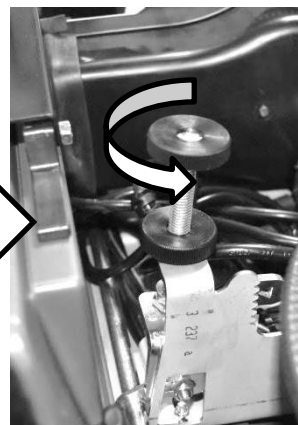
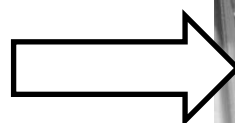

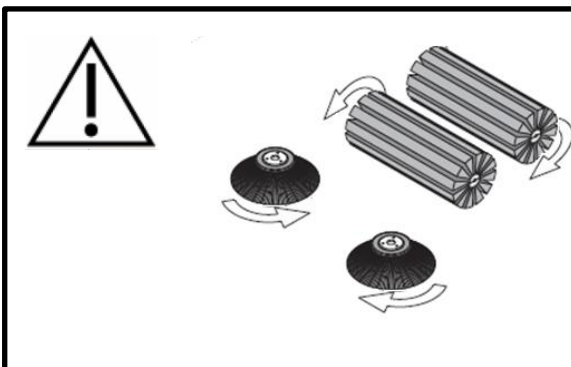
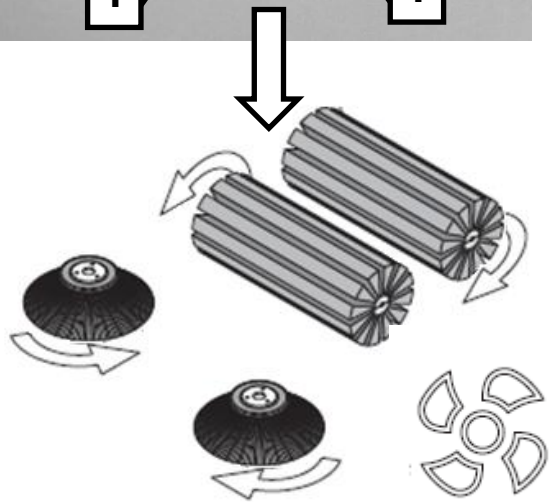
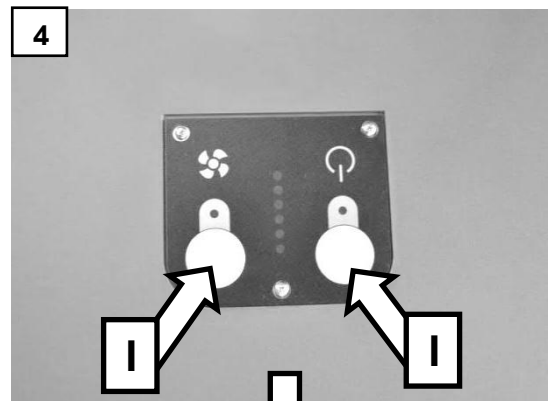
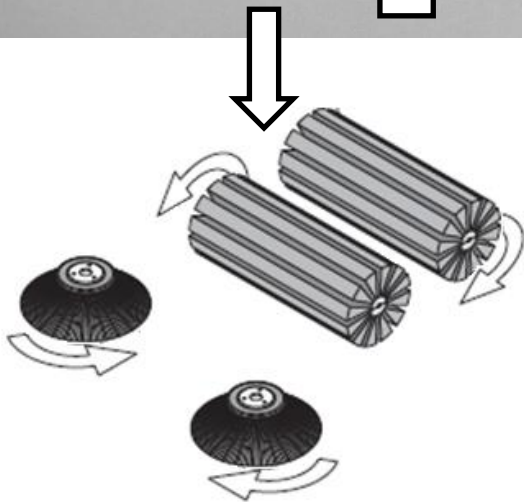
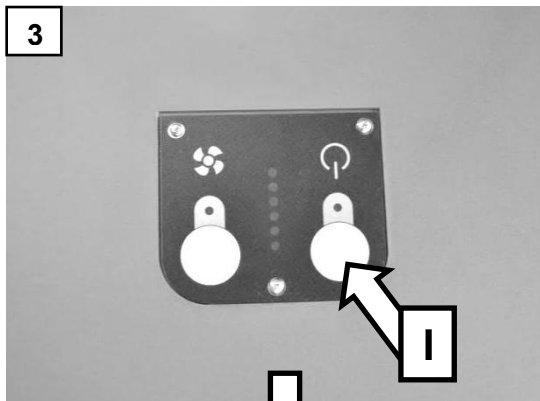
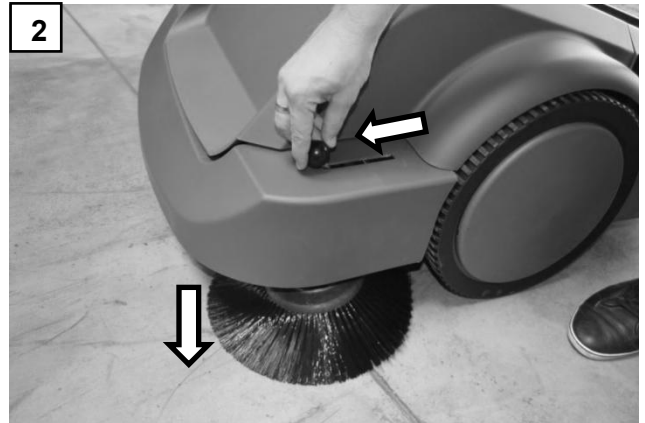
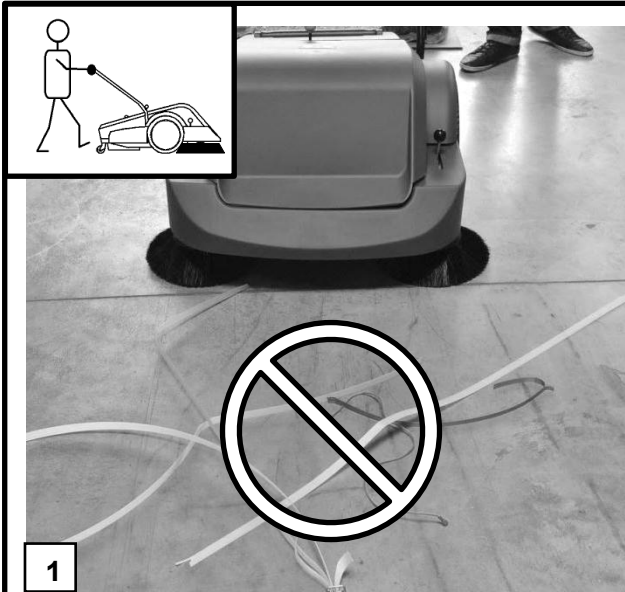

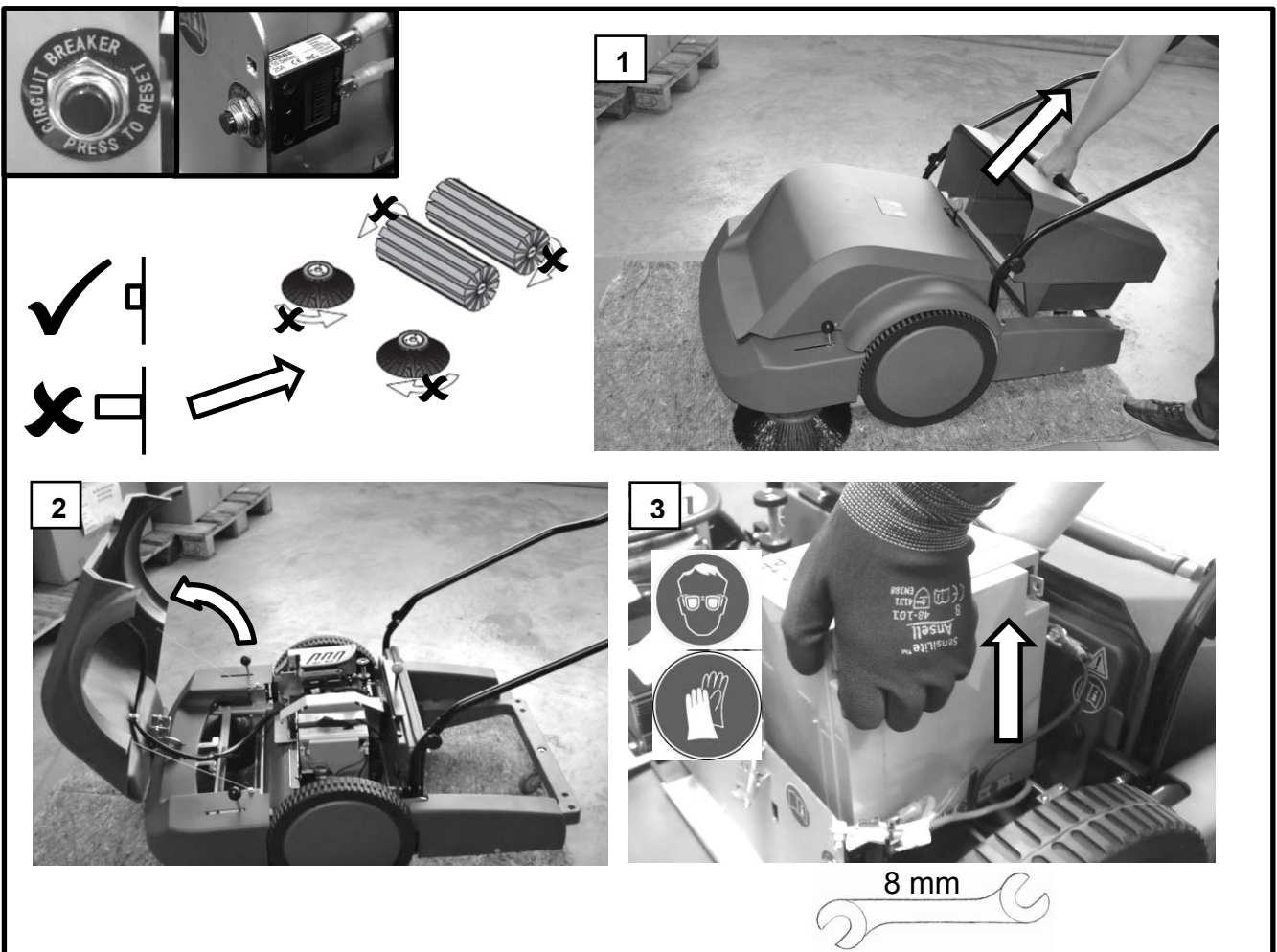
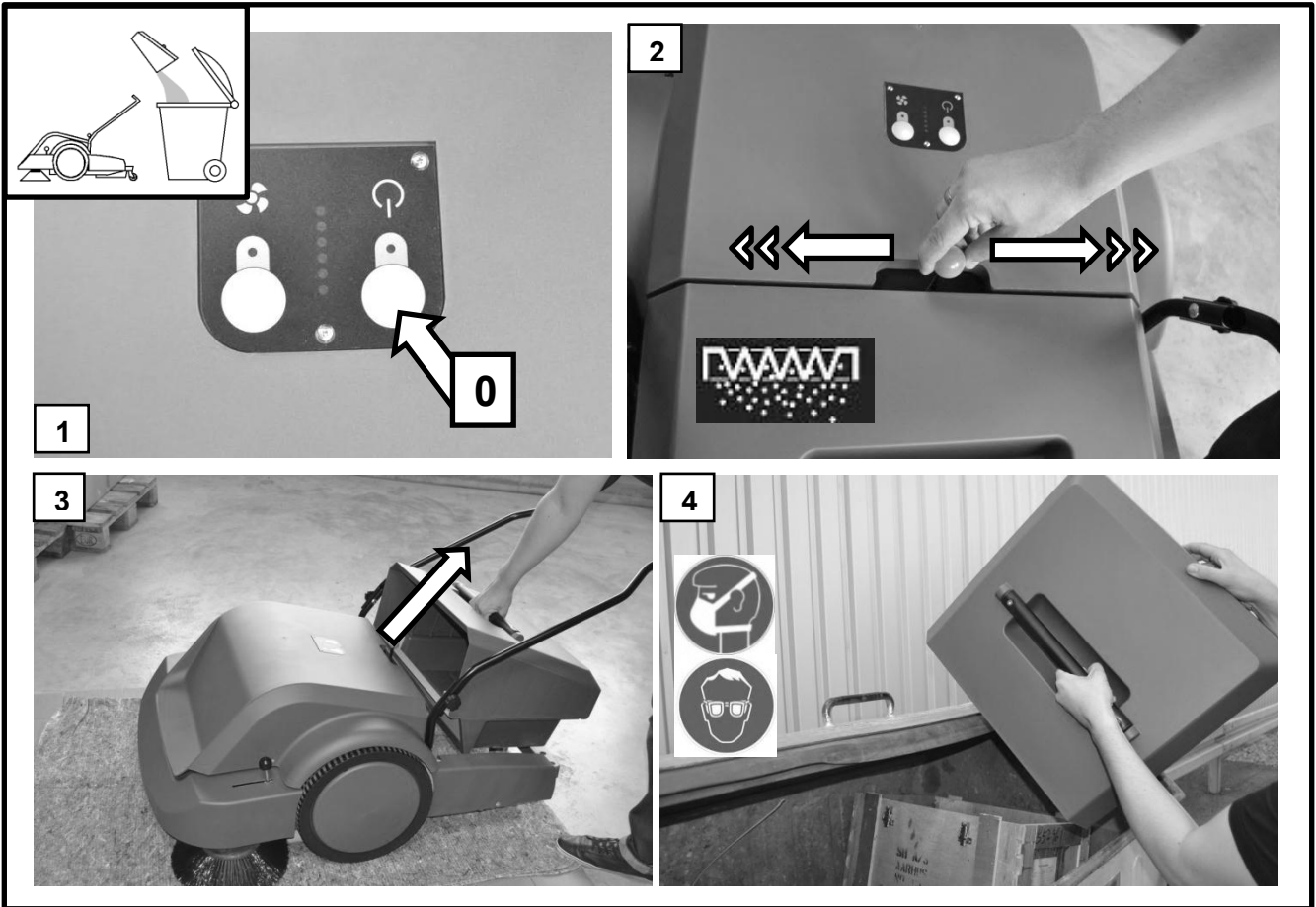

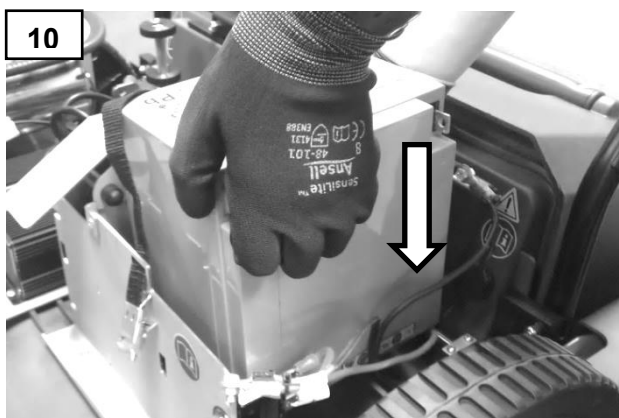
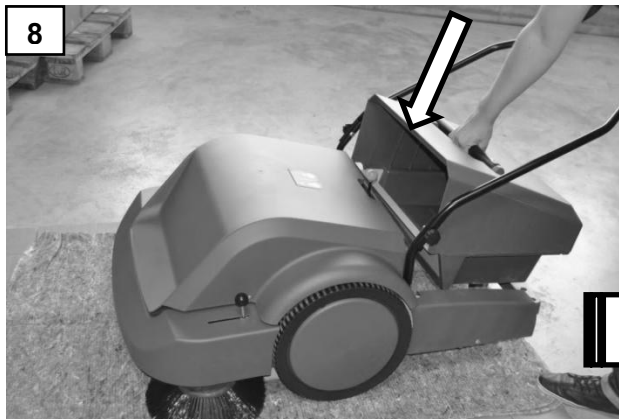
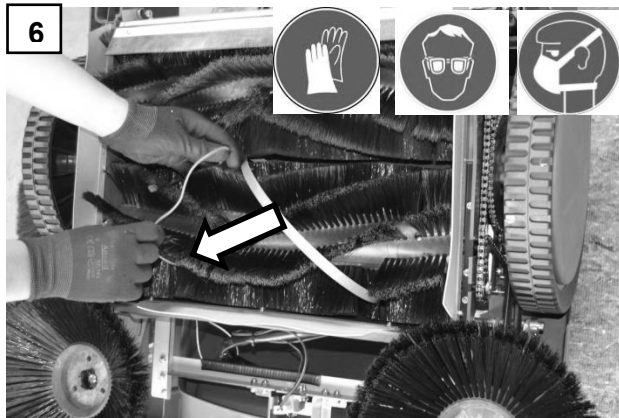
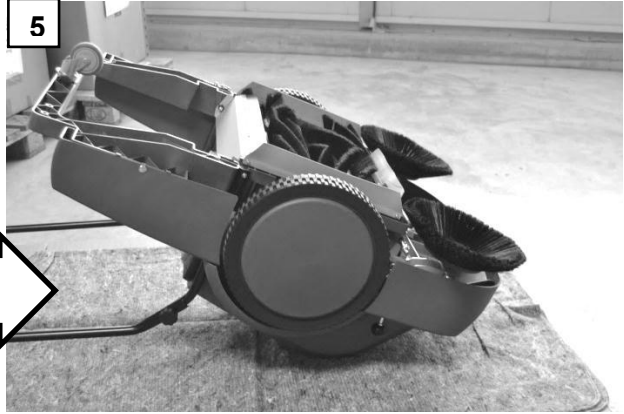
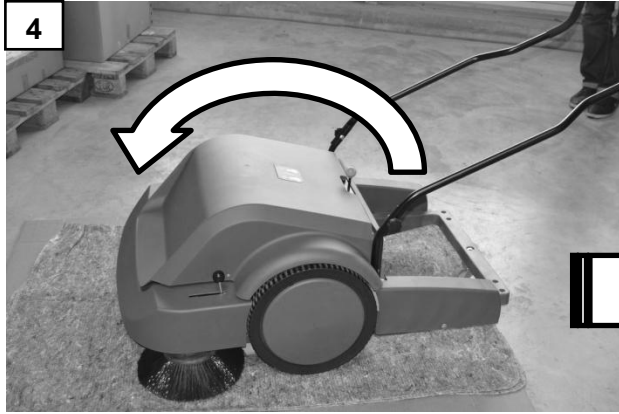

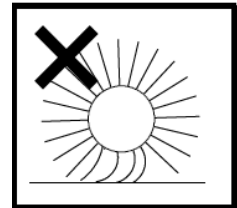
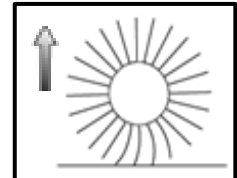
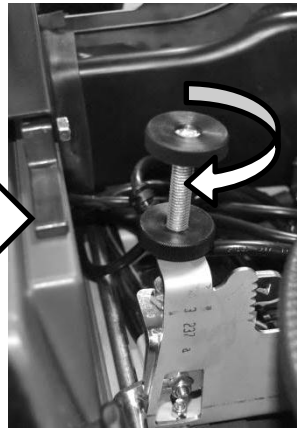
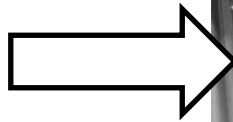
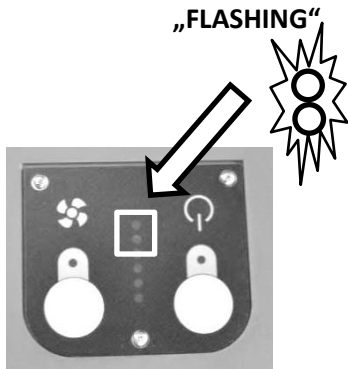
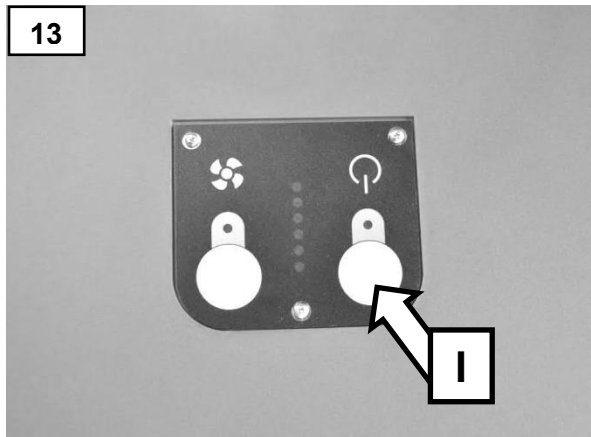
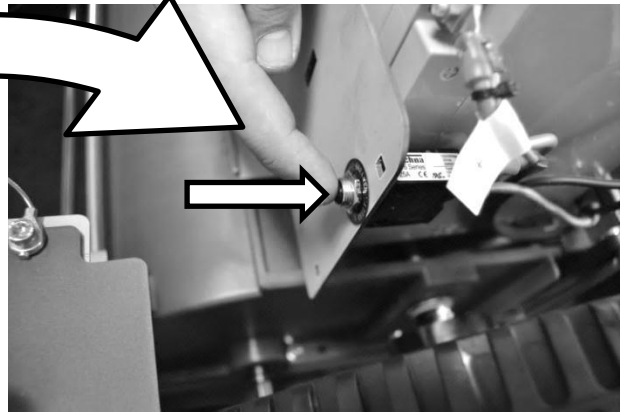

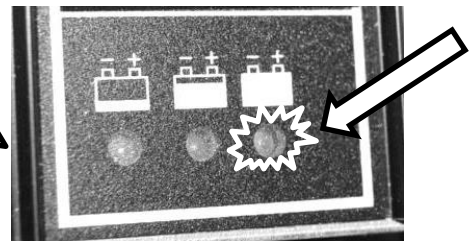
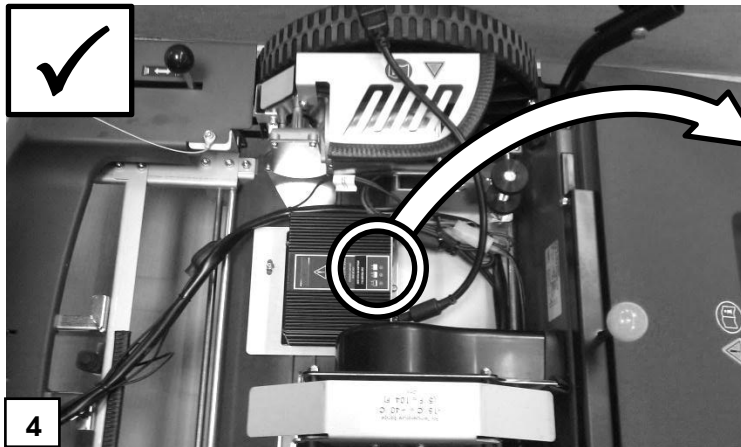
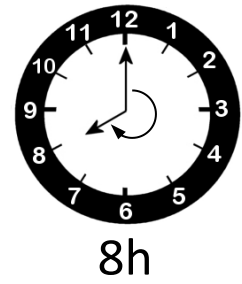
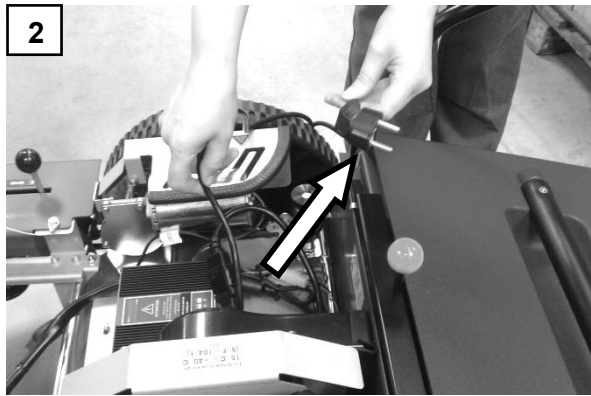
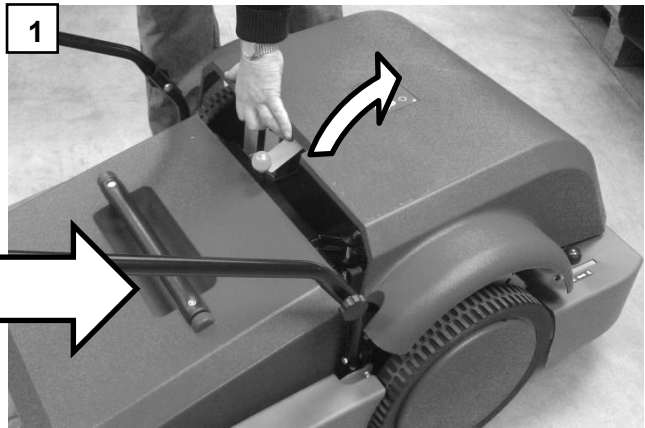
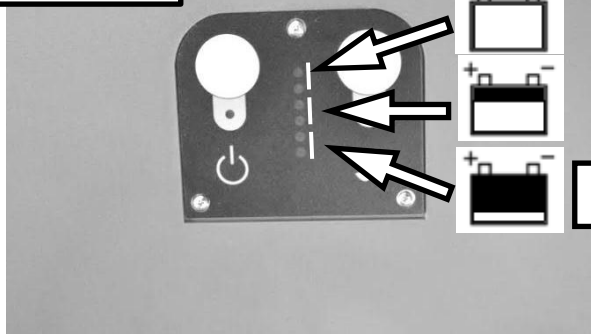
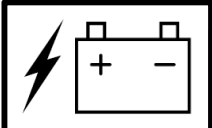

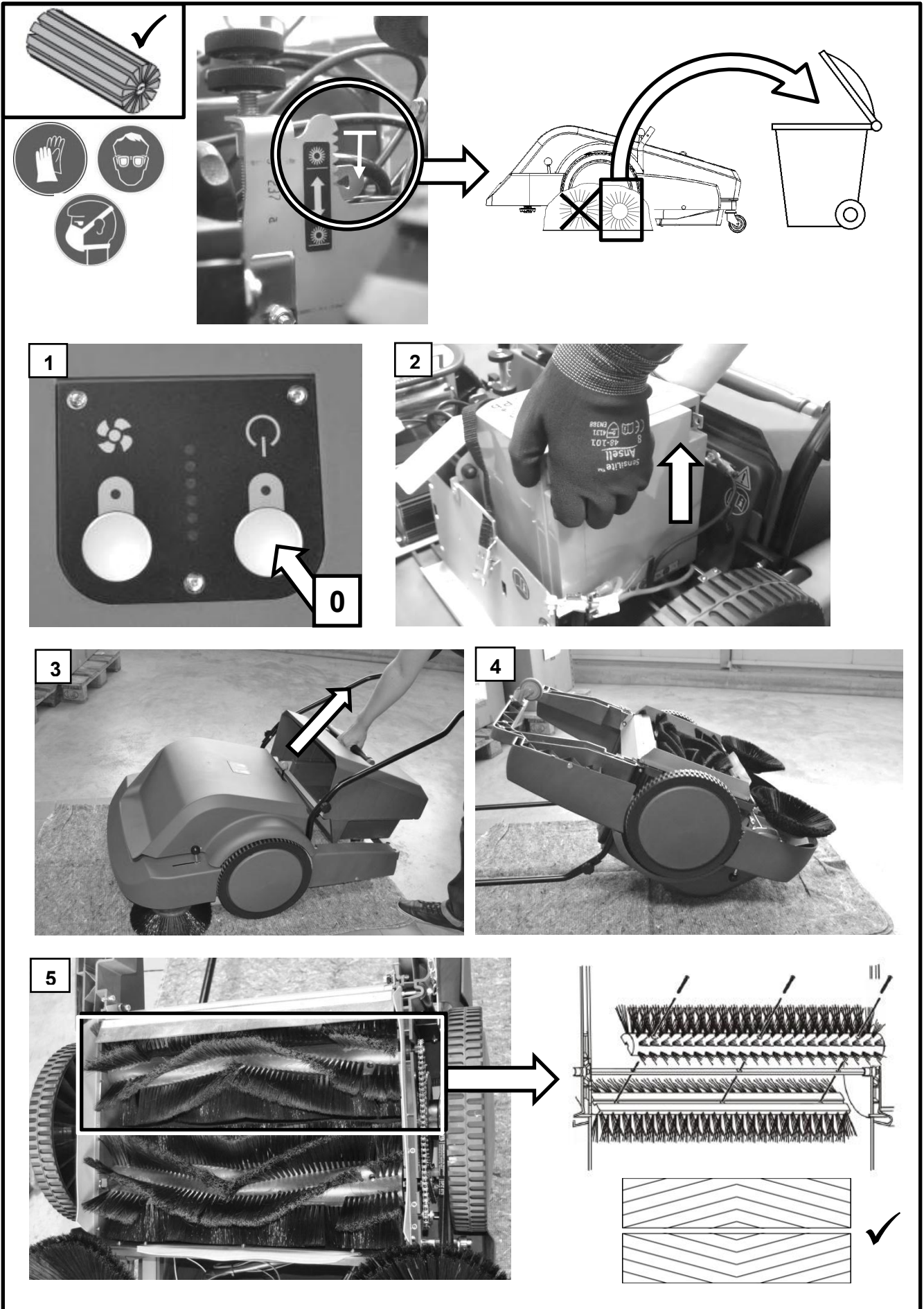

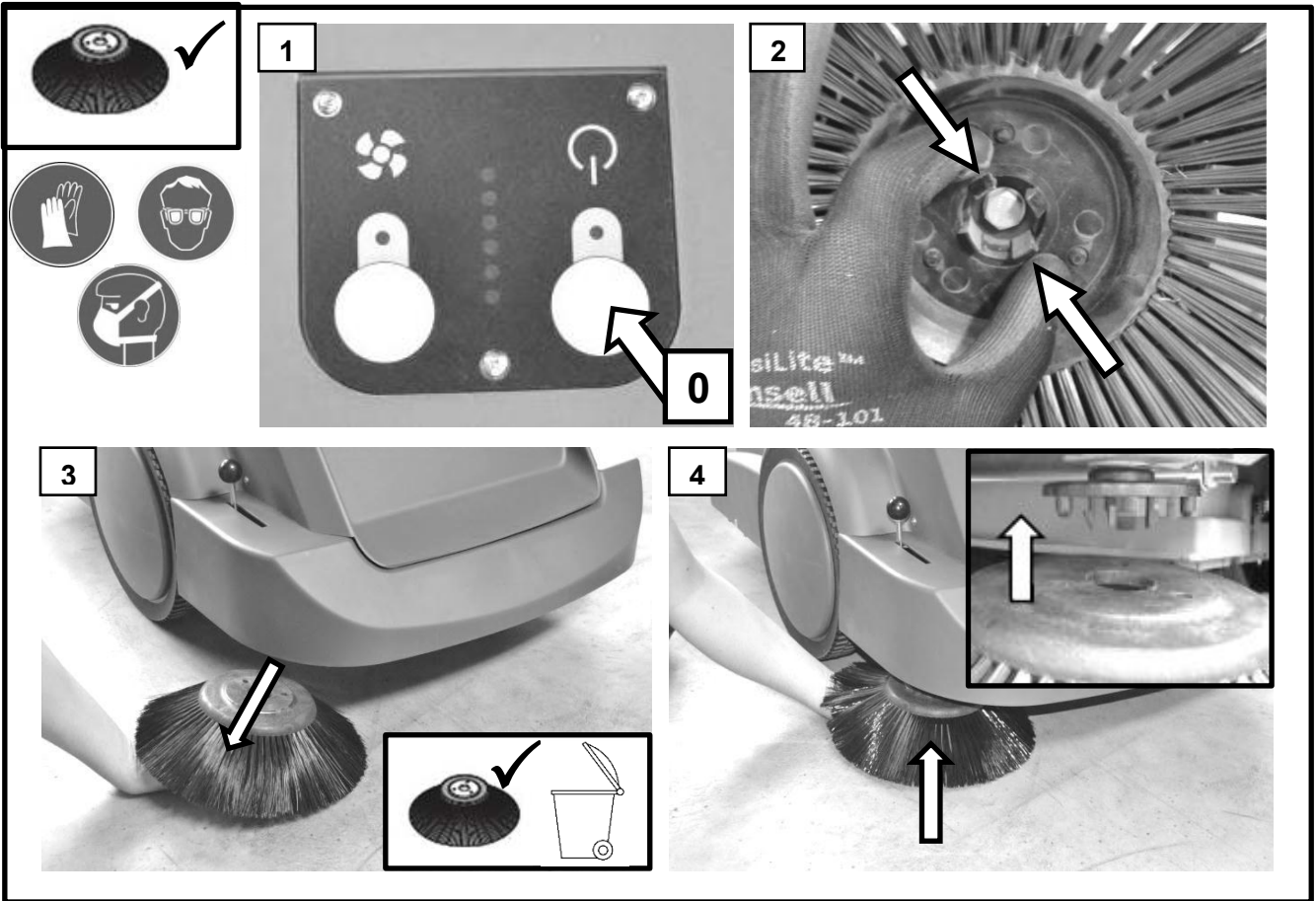

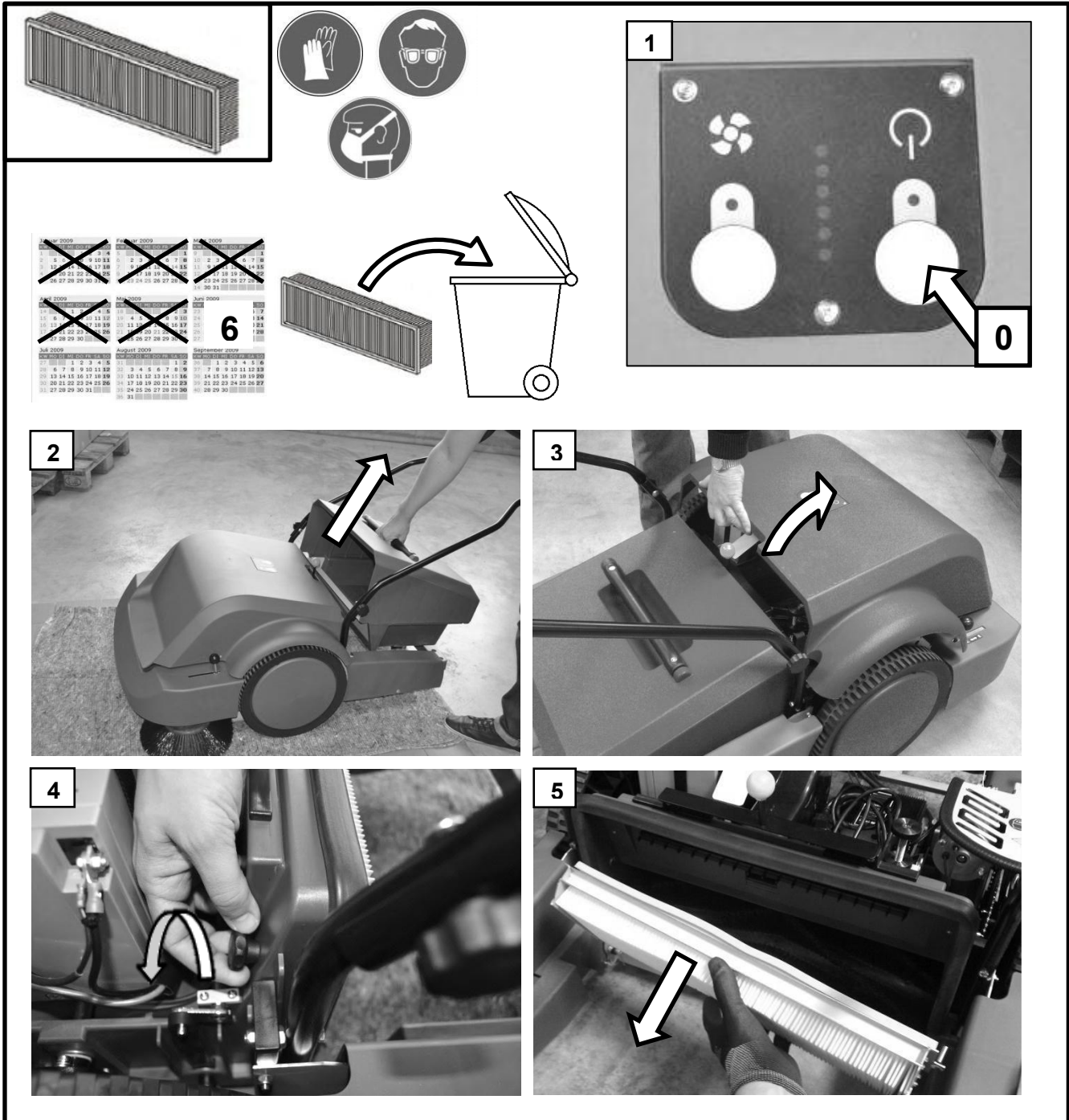

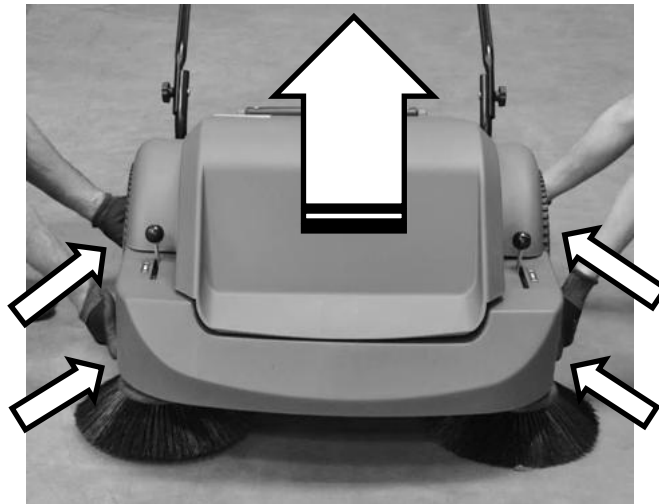
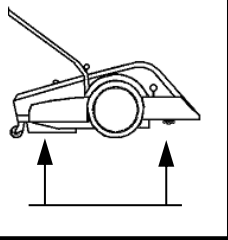
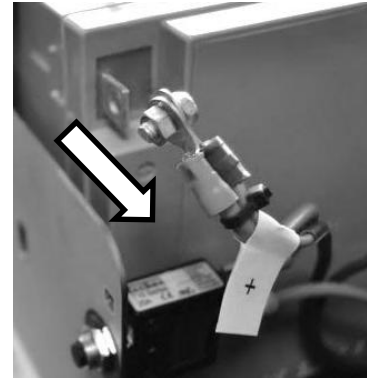
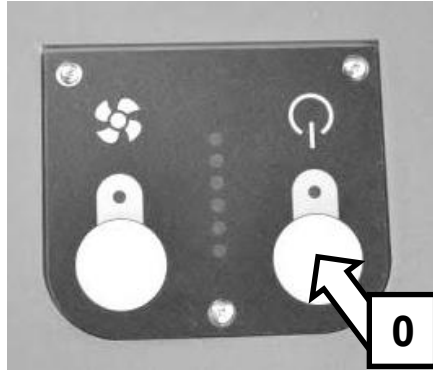
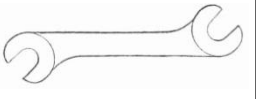
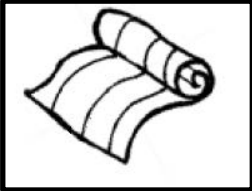

**POWER EQUIPMENT  
Walk Behind Sweeper**

MODEL:	XXX	POWER:	430 W
MATERIAL NO.:	XXXXXXX	VOLTAGE:	12 V
SERIAL NUMBER:	XXX XXX XXX	CURRENT:	13 A
DC:	XXXX	WEIGHT-NET :	47 kg
PROTECTION:	IPX3	WEIGHT- WITH BATTERY:	56 kg
		SOUND PRESSURE:	65 dB

TENNANT COMPANY  
701 North Lilac Drive  
P.O. Box 1452  
Minneapolis, MN 55440 USA  
1-800-553-8033  
www.tennantco.com

2%   
Made in Germany



Fig. 1 – Cover and Handle Group

Ref.	Part No.	Description	Qty.	
▽	1	9010108	Front Cover Kit, Teal (Includes Front Cover Qty 1, Wires Qty 2, Warning Label Qty 1 & Mounting Hardware)	1
▲	2	N/A	Screw, Soc, M6x1x12	2
▽	3	9010016	● Controller Kit (Includes Mounting Hardware)	1
▲	4	N/A	Screw, Pan, 2.9x6.5 TCUT	5
	5	9010009	● Seal Kit ( Includes Hopper Seal Qty 1, Fan Seal Qty1, Edging Qty 2, Battery Strap Qty 1, Strap Bracket Qty1)	1
▽	6	9010110	Shroud Kit, HG( Including Front Shroud Qty 1, lh Rear Cover Qty 1, rh Rear Cover Qty 1, Clamp Qty 2 & Mounting Hardware)	1
▲	7	N/A	Bolt, Carriage M6x1x16	2
▲	8	N/A	Washer, Flat, M6 x 20	2
▲	9	N/A	Nut, Hex, Lock, M6x1, NL	2
▲	10	N/A	Washer, Flat M6	4
▽	11	9010014	● Switch Kit, Safety	1
▲	12	N/A	Screw, Soc, M5x0.8x16	2
▲	13	N/A	Nut, Hex, Lock, M5x0.8, NL	2
▲	14	N/A	Screw, Soc, M6x1x16	2
▲	15	N/A	Nut, Hex, Lock, M6x1, NL	2
▲	16	N/A	Screw, Pan, 5x30 TCUT	2
▽	17	9010113	Handle Bracket Kit (Includes lh Handle Bracket Qty 1, rh Handle Bracket Qty 1, Square Tube Qty 2, lh Support Qty 1, rh Support Qty 1 & Mounting Hardware)	1
▲	18	N/A	Bolt, Carriage, M6x1x50	4
▲	19	N/A	Screw, Hex, M6x1x45	2
	20	N/A	Bolt, Carriage, M6x1x60	2
▲	21	N/A	Screw, Soc, M6x1x16	6
▲	22	N/A	Nut, Hex, Jam, M8x1.25	2
▲	23	N/A	Nut, Hex, Lock, M6x1, NL	12
	24	9009993	● Handle, Kit (Includes Soft Grip)	1
▽	25	9009994	● Handle Knob Kit	1
▲	26	N/A	Bolt, Carriage, M6x1x35	2
	27	9010012	Hopper, Kit , Teal	1
	28	9010125	Shroud Mounting Kit (Includes Hinge Qty 1, Switch Actuator Qty 1, Brackets Qty 5	1
	29	9010101	Label Kit ( Includes Logo Tennant Qty 1, Logo S3B Qty 2, Label Warning NA Qty 1, Label Warning EU Qty 1, Label Side Brush Qty 2, Label Main Brush Qty 1, Label Shaker Qty 1)	1
▽	30	9009647	● Strap Kit, Static (Includes Static Chain & Mounting Hardware)	1
▲	31	N/A	Screw, Hex, M4x0,75x16	1
▲	32	N/A	Washer, Flat M4	1
▲	33	N/A	Nut, Hex, Lock M4	1
▲	34	N/A	Screw, Pan, 3,5x13 TCUT	2
▲	35	9010009	● Seal Kit ( Includes Hopper Seal Qty 1, Fan Seal Qty1, Edging Qty 4, Battery Strap Qty 1, Strap Bracket Qty1)	1

▽ ASSEMBLY

▲ INCLUDED IN ASSEMBLY

● RECOMMENDED STOCK ITEM

N/A Not Available Separately. Local Purchase.

Fig. 2 – Main Brush and Wheel Group

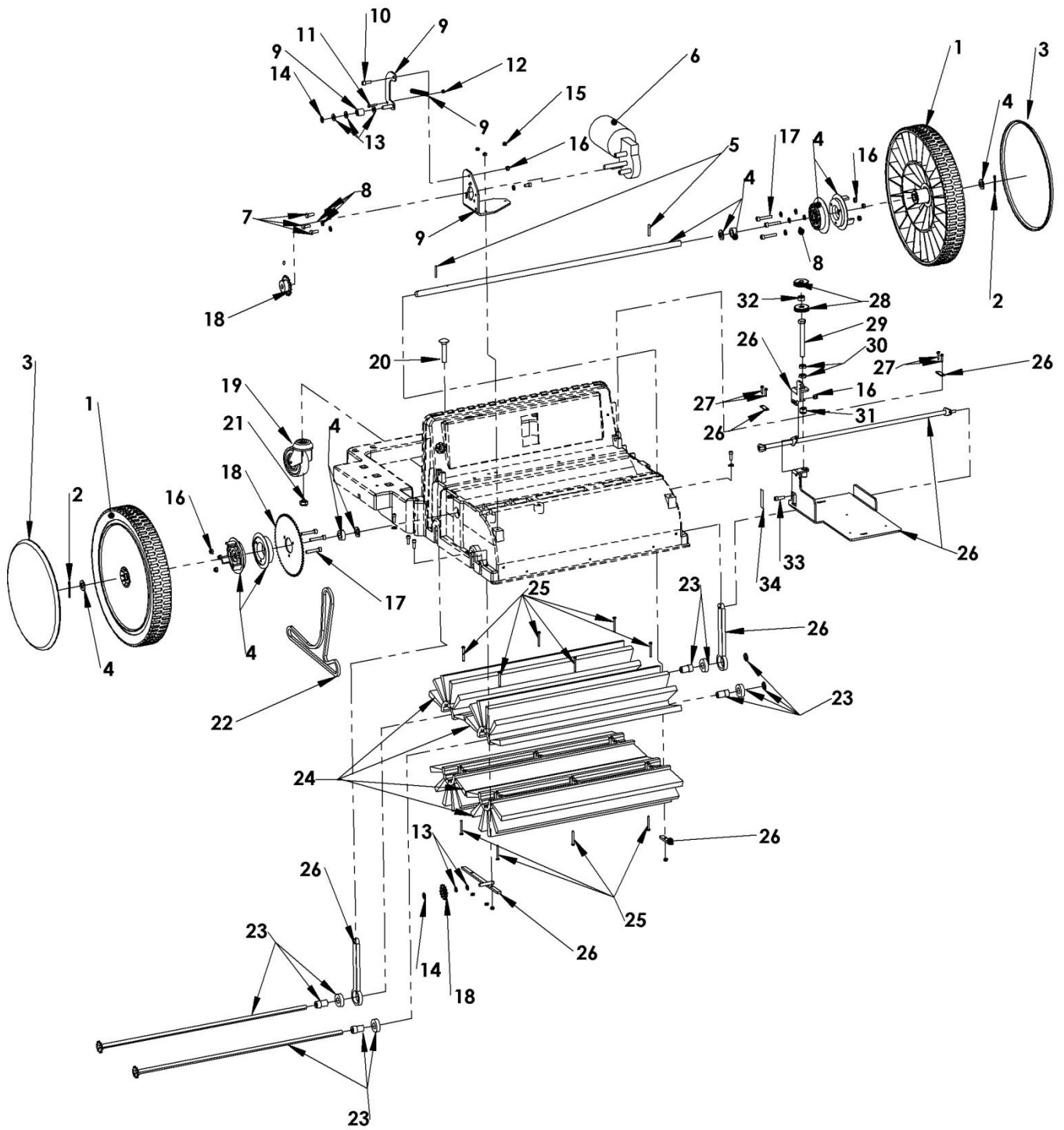

Fig. 2 – Main Brush and Wheel Group

Ref.	Part No.	Description	Qty.
▽	1	9010018 ● Wheel Kit (Includes Wheel Qty 1, Bearings Qty 2 & Mounting Hardware)	2
▲	2	N/A Cotter Pin 3,2x40	2
	3	9010019 ● Hub Cap Kit, Teal (Includes Qty 2)	1
▽	4	9010024 Drive Axle Kit ( Including Shaft Qty 1, Bearings Qty 2, Driver Outside Qty 2, Driver Inside Qty 2, Felt Washer Qty 4 & Mounting Hardware)	1
▲	5	N/A Cylinder pin Ø4x30	2
▽	6	9010017 ● Main Brush Motor Kit ( Includes Motor Qty 1 & Mounting Hardware)	1
▲	7	N/A Screw, Hex, M6x1x16	3
▲	8	N/A Washer, Flat, M6	9
▽	9	9010118 Main Brush Chain Tensioner Kit (Includes Motor Bracket Qty 1, Tensioning Arm Qty 1, Motor Guard Qty 1, Spring Qty 1, Chain Roller Qty 1 & Mounting Hardware)	1
▲	10	N/A Screw, Soc, M6x1x16	1
▲	11	N/A Screw, Hex, M4x0.7x20	1
▲	12	N/A Nut, Hex, Lock, M4x0.7, NL	1
▲	13	N/A Washer, Flat, M8	5
▲	14	N/A Retainment Ring Ø8	2
▲	15	N/A Nut, Hex, Lock, M5x0.8, NL	3
▲	16	N/A Nut, Hex, Lock, M6x1, NL	7
▲	17	N/A Screw, Soc, M6x1x35	6
	18	9010116 ● Spocket Kit (Includes Motor Sprocket Qty 1, Drive Sprocket Qty 1 , Deflection Sprocket Qty 1 & Mounting Hardware)	1
▽	19	9010021 ● Caster Kit (Includes Mounting Hardware)	1
▲	20	N/A Bolt, Carriage, M10x1.5x55	1
▲	21	N/A Nut, Hex, Lock, M10x1.5, NL	1
	22	9010022 ● Main Brush Chain	1
	23	9010111 Main Brush Axle Kit ( Includes Axle Qty 1, Bushing Qty 2, Bearing Qty 2, Square 8 Retainment Ring Qty 1	2
▽	24	9009995 ● Main Brush Kit ( Includes Brush Half Shell Qty 2 & Mounting Hardware)	2
▲	25	N/A Screw, Pan, 3.9x38, TCUT	12
▽	26	9010119 Main Brush Adjustment Kit (Includes Adjustment Axle Qty 1, Fixing Brackets Qty 2, Charger Mounting Bracket Qty 1, Pointer Qty 1, Main Brush Lever Qty 2 & Mounting Hardware)	1
▲	27	N/A Screw, Pan, 3.5x13, TCUT	4
▽	28	9010011 ● Knob Kit (Includes Black Balls M8 Qty 2, Yellow Balls M8 Qty 1, Knurled Screw M10 Qty 2 & Mounting Material)	1
▲	29	N/A Screw, Hex, M10x1.5x90	1
▲	30	N/A Nut, Hex, Jam, M10x1.5	2
▲	31	N/A Nut, Hex, Lock, M10x1.5, NL	1
▲	32	N/A Nut, Hex, Std, M10x1.5	1
▲	33	N/A Screw, Soc, M6x1x20	1
	34	9010101 ● Label Kit ( Includes Logo Tennant Qty 1, Logo S3B Qty 2, Label Warning NA Qty 1, Label Warning EU Qty 1, Label Side Brush Qty 2, Label Main Brush Qty 1, Label Shaker Qty 1)	1

▽ ASSEMBLY

▲ INCLUDED IN ASSEMBLY

● RECOMMENDED STOCK ITEM

N/A Not Available Separately. Local Purchase.

Fig. 3 – Side Brush and Dust Flap Group

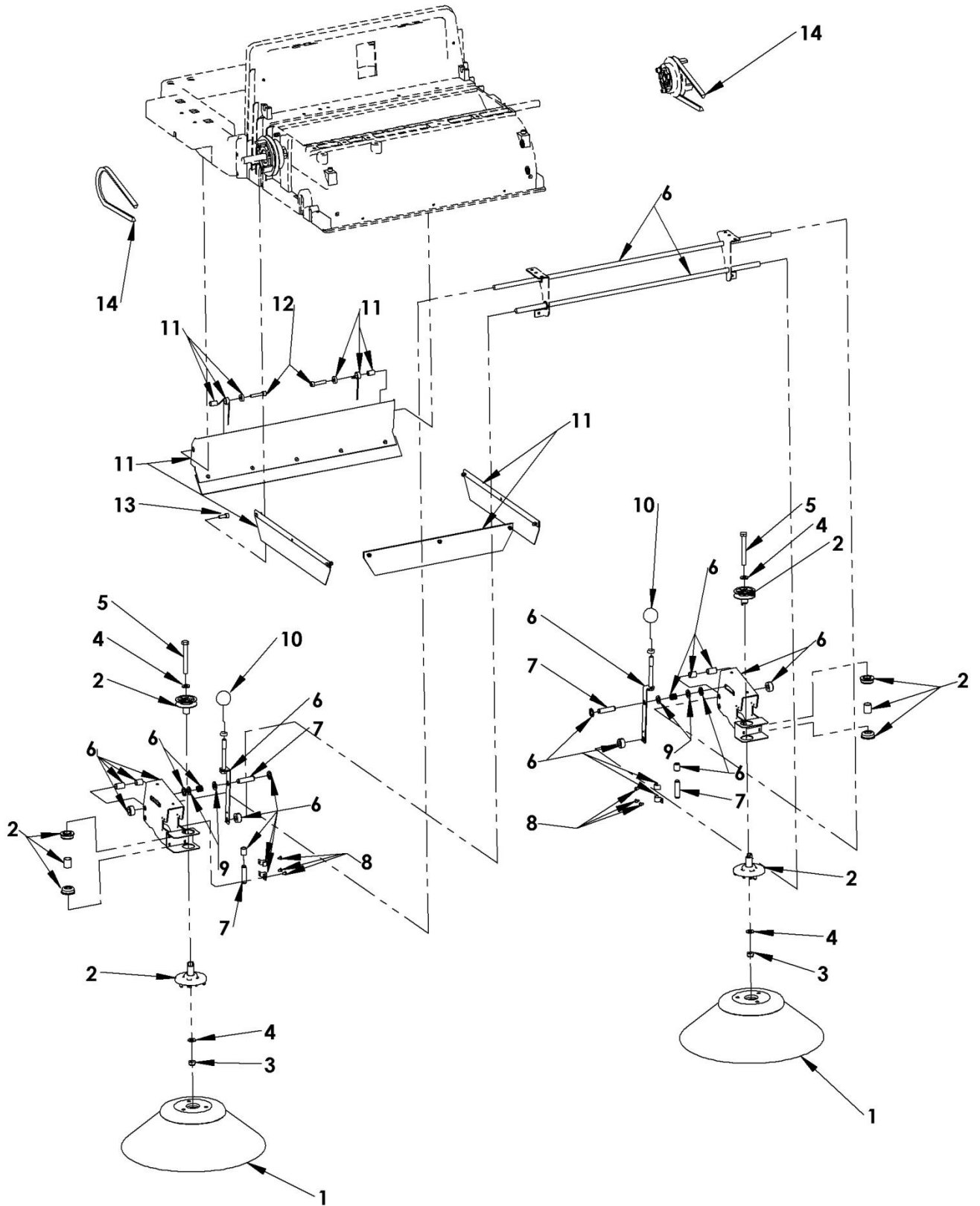

**Fig. 3 – Side Brush and Dust Flap Group**

Ref.	Part No.	Description	Qty.
	1	● Side Brush Pack Qty 1	2
▽	2	● Side Brush Pulley Kit (Includes Pulley Kit Qty 1, Bearings Qty 2, Bushing Qty 1 & Mounting Hardware)	2
▲	3	N/A Nut, Hex, Lock, M8x1.25, NL	2
▲	4	N/A Washer, Flat, M8	4
▲	5	N/A Screw, Hex, M8x1.25x70	2
▽	6	9010026 Side Brush Lift Kit (Includes Adjustment Lever Qty 2, rh Bracket Qty 1, lh Bracket Qty 1, Bearings Qty 4, Spring Qty 2, Axle 1 Qty 1, Axle 2 Qty 2 & Mounting Hardware)	1
▲	7	N/A Cylinder Pin 10x40	4
▲	8	N/A Screw, Pan, 3.9x6.5 TCUT	6
▲	9	N/A Washer, Flat, M10	4
	10	9010011 Knob Kit (Includes Black Balls M8 Qty 2, Yellow Balls M8 Qty 1, Knurled Screw M10 Qty 2 & Mounting Material)	1
▽	11	9009996 ● Flap Kit (Includes Side Rubber Strip Qty 2, Front Rubber Strip Qty 1, Rear Flap Qty 1, Springs & Mounting Hardware)	1
▲	12	N/A Screw, Soc, M6x1x30	2
▲	13	N/A Screw, Soc, M6x1x16	1
	14	9010025 ● Belt, Side Brush	2

▽ ASSEMBLY

▲ INCLUDED IN ASSEMBLY

● RECOMMENDED STOCK ITEM

N/A Not Available Separately. Local Purchase.

Fig. 4 – Fan, Filter, Battery and Electric Group

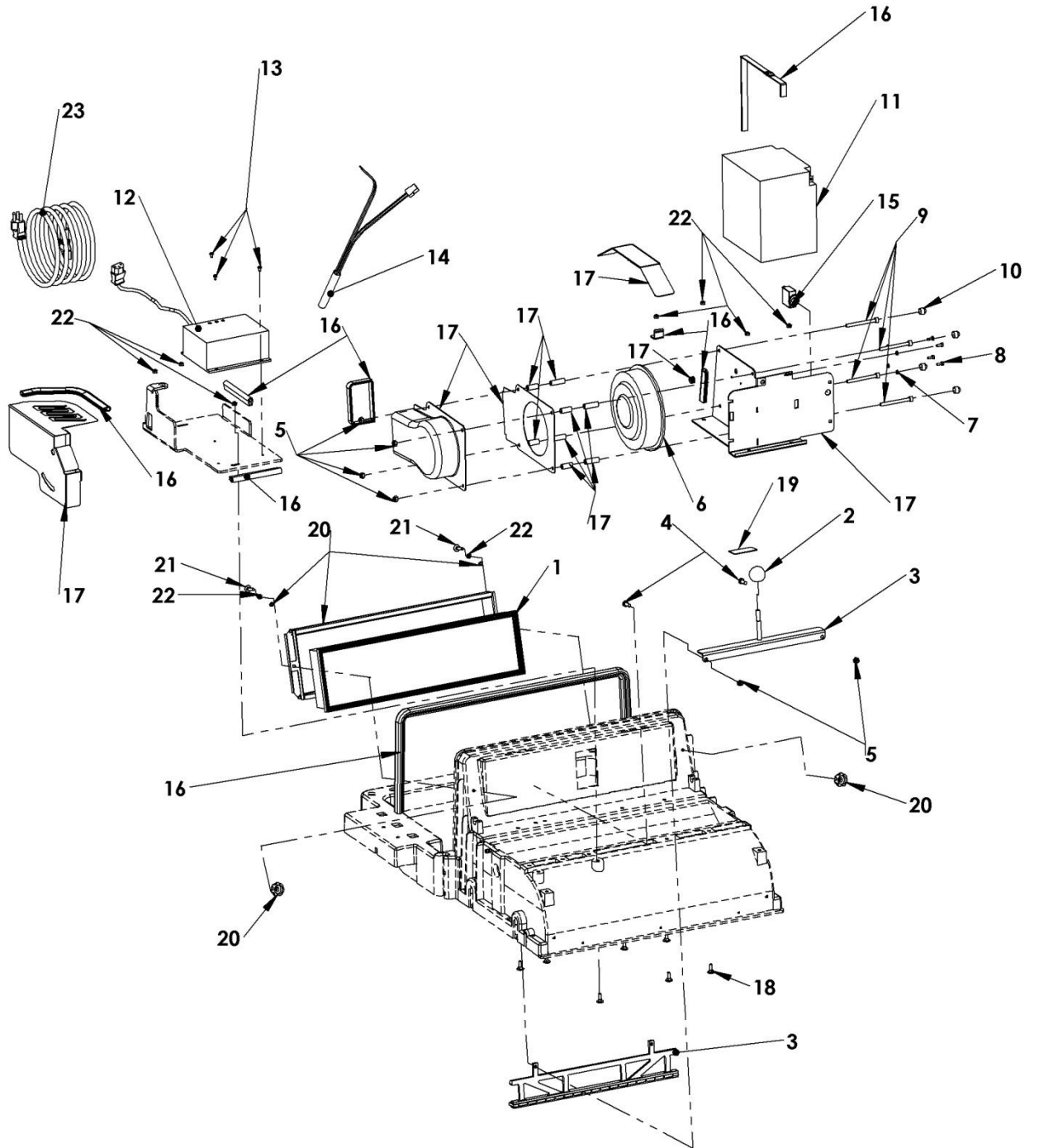

Fig. 4 – Fan, Filter, Battery and Electric Group

Ref.	Part No.	Description	Qty.
1	9009998	● Filter	1
2	9010011	● Knob Kit (Includes Black Balls M8 Qty 2, Yellow Ball M8 Qty 1, Knurl Knob Assy Qty 1)	1
▽	3	9010060 Shaker Kit (Includes Shaker Qty 1, Shaker Lever Qty 1 & Mounting Hardware)	1
▲	4	N/A Screw, Hex, M6x1x16	2
▲	5	N/A Nut, Hex, Lock, M6x1,NL	6
▽	6	9010027 ● Blower Kit (Includes Fan Qty 1 & Mounting Hardware)	1
▲	7	N/A Washer, Lock, M4	4
▲	8	N/A Screw, Hex, M4x0.7x10	4
▲	9	N/A Screw, Soc, M6x1x65	4
▲	10	N/A Protection Caps	4
	11	1068827 ● Battery 12V 26 Ag, Gel	1
▽	12	9010015 ● Charger Kit (Includes Charger 12V - 5A Qty 1 & Mounting Hardware)	1
▲	13	N/A Screw, Pan, 3.9x9.5 TCUT	3
	14	9010028 Wire Harness	1
	15	9010127 ● Circuit Breaker	1
▲	16	9010009 ● Seal Kit ( Includes Hopper Seal Qty 1, Fan Seal Qty1, Edging Qty 4, Battery Strap Qty 1, Strap Bracket Qty1	1
▽	17	9010120 Bracket Kit (Includes Battery Support Qty 1, Fan Housing Qty 1, Cover Plate Qty 1 , Fan Guard Qty 1, Motor Guard Qty 1, & Mounting Hardware)	1
▲	18	N/A Bolt, Carriage, M5x0.8x16	7
	19	9010101 ● Label Kit ( Includes Logo Tennant Qty 1, Logo S3B Qty 2, Label Warning NA Qty 1, Label Warning EU Qty 1, Label Side Brush Qty 2, Label Main Brush Qty 1, Label Shaker Qty 1)	1
▽	20	9010129 Filter Holder Kit(Includes Filter Holder Qty 1, O-Ring Qty 2, Knurl Nut Qty 2 & Mounting Hardware)	1
▲	21	N/A Bolt, Carriage, M5x0.8x25	2
▲	22	N/A Nut, Hex, Lock, M5x0.8, NL	9
	23	1044067 ● Cord, Power, 16/3 BLK [2,5meter, NA]	1
		989722 ● Cord, Power, BLK [3meter, JP]	
		1044069 ● Cord, Power, BLK [2,5meter, BRZL/UK]	
		1044068 ● Cord, Power, BLK [2,5meter, KOR/CE]	
		1026325 ● Cord, Power, 1.0mm2/3 BLK [2,5meter, AUS]	
		1026330 ● Cord, Power, 1,000mm2 BLK [2,5meter, CHINA]	

▽ ASSEMBLY

▲ INCLUDED IN ASSEMBLY

● RECOMMENDED STOCK ITEM

N/A Not Available Separately. Local Purchase.

# Electrical Diagram

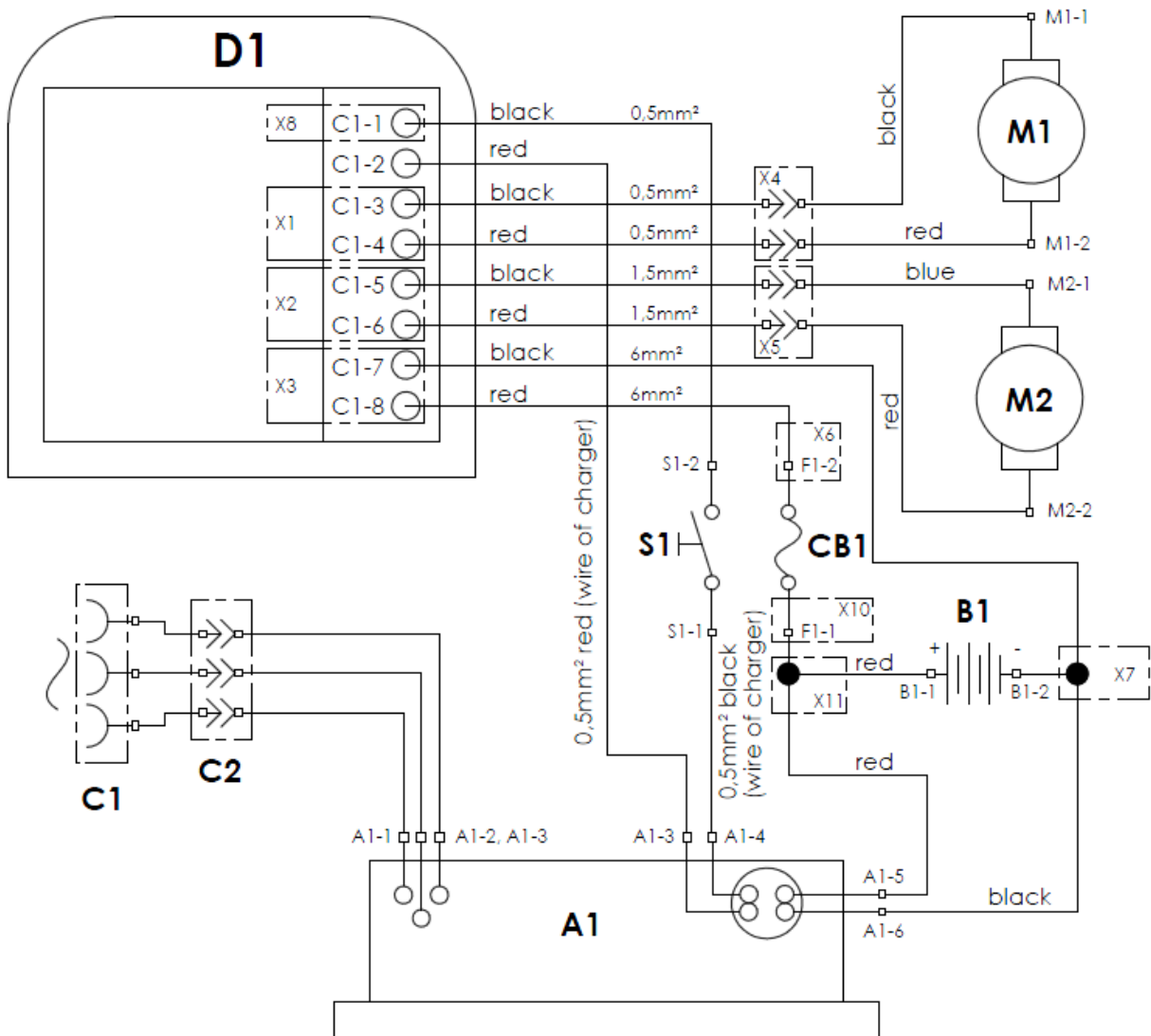

Legend	
Symbol	Description
A1	charger
B1	battery
C1	charging plug
C2	rubber connector
CB1	circuit breaker
D1	controller
M1	vacuum fan
M2	gear motor
S1	cover contact switch
X1 - X11	connectors of cable harness