



Electronic Service Manuals

This electronic document is provided as a service to our customers. We do not create the contents of the information contained in this document. Should you have detailed questions pertaining to the information contained in this document, you may contact Michco, or the manufacturer which provided the original information in this electronic deliverable. Michco's only part in this electronic deliverable was the electronic assembly process. By providing this manual on line we are not guaranteeing parts availability.

You may contact Michco through the following methods:

Phone (517) 484-9312 or (800) 331-3339

2011 N. High St. -- Lansing, Michigan -- 48906

Fax: (517) 484-9836

Email: CustServe@Michco.com

Web site: www.Michco.Com

Parts Web site: www.FloorMachineParts.Com

Order Parts on Line at:

www.FloorMachineParts.Com

Directly to Parts & Service:

By Email: **Shop@Michco.com**

By Fax: (517) 702-2041

By Voice: Use numbers above.

Serving the Cleaning Industry Since 1922

Notice: All copyrighted material remains property of original owners, all trademarks are property of respective owners. Manuals are subject to Manufacturer's reproduction limitations. Originals or reproductions were provided by manufacturers through a request. We make no warranty as to the correctness of information provided in this document and you assume all risk. By placing these manuals on line we are not declaring our corporation to be an manufacturer authorized dealer or provider, please check our web site for authorized manufacturers we represent.



275

Parts Manual

MM151

Home

Find...

Go To..





This manual is furnished with each new TENNANT® Model 275. It provides necessary operating and preventive maintenance instructions. Read this manual completely and understand the machine before operating or servicing it.

This manual covers all machine variations and standard accessories. The tabbed instruction portion of the manual consists of the Specification, Operation, Maintenance, and Appendix sections. The tabbed parts section consists of the Low Dump Model Parts; LPG Parts; Multi-Level Dump Model Parts; Accessories; Hydraulic Components; Engine Parts sections.

All right side and left side references to the machine are determined by facing the direction of forward travel. All hardware considered to be of a common nature or locally available has been omitted from the parts sections. Be aware that this machine may contain metric hardware. Make sure you use equivalent hardware when replacement becomes necessary.

This machine will provide excellent service. However, the best results will be obtained at minimum costs if:

- The machine is operated with reasonable care.
- The machine is maintained regularly – per the maintenance instructions provided.
- The machine is maintained with Tennant Company supplied or equivalent parts.

Parts and supplies may be ordered by phone or mail from any Tennant Company parts and service center, distributor, or from any of the Tennant Company subsidiaries. Before ordering parts or supplies, be sure to have your machine model number and serial number handy. Fill out the data block below for future reference. The telephone numbers, telex numbers, mailing addresses, and locations of those outlets are listed in the Customer Documents section of the manual.

MACHINE DATA	
<i>Please fill out at time of installation.</i>	
Machine Serial Number -	_____
Engine Serial Number -	_____
Sales Representative -	_____
Date of Installation -	_____
Manual Number -	MM151
Revision:	07
Published:	1-88

03945

Trademark Registered in: Austria, Benelux, Denmark, England, France, Germany, Italy, Spain, Switzerland, United States, Argentina, Australia, Canada, Japan, Mexico, Sweden, by TENNANT COMPANY, Minneapolis, Minnesota, U.S.A.

Acknowledgements: Technical information and/or illustrations supplied by Ford Motor Company; Cessna Fluid Power Division; Eaton Corporation, Hydraulics Division.

Copyright 1986, 1987, 1988 Tennant Company, Printed in U.S.A.

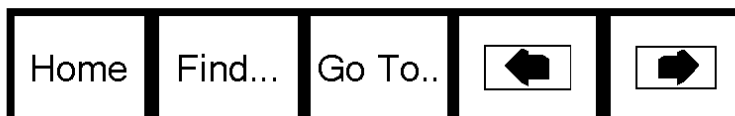

SECTION 5

LOW DUMP MODEL PARTS

CONTENTS

	Page		Page
Ordering Repair Parts	5-1	Fig. 33 - Muffler Group	5-52
Fig. 1 - Recommended General Maintenance Items	5-2	Fig. 34 - Fuel Tank Group	5-53
Fig. 2 - Replacement Brushes	5-4	Fig. 35 - Labels Group	5-54
Fig. 3 - Main Frame Group	5-6		
Fig. 4 - Seat and Radiator Group	5-8		
Fig. 5 - Engine Cover and Side Door Group	5-10		
Fig. 6 - Hopper Group	5-12		
Fig. 7 - Hopper Cover and Filter Shaker Group	5-14		
Fig. 8 - Hopper Lift Arms Group	5-16		
Fig. 9 - Side Brush Group	5-18		
Fig. 10 - Front Wheel and Brakes Group	5-20		
Fig. 11 - Steering Control Group	5-22		
Fig. 12 - Rear Wheel Drive Group	5-24		
Fig. 13 - Main Brush Drive Group	5-26		
Fig. 14 - Main Brush Lift Group	5-28		
Fig. 15 - Access and Kicks Panels Group	5-30		
Fig. 16 - Vacuum Fan Group	5-31		
Fig. 17 - Instrument and Control Panels Group	5-32		
Fig. 18 - Battery Group	5-33		
Fig. 19 - Wire Harness Group	5-34		
Fig. 20 - Hydraulic Hoses Group	5-36		
Fig. 21 - Hydraulic Pumps Group	5-38		
Fig. 22 - Hydraulic Reservoir Group	5-39		
Fig. 23 - Hydraulic Control Valve Group	5-40		
Fig. 24 - Hydraulic Solenoid Valve Group	5-41		
Fig. 25 - Hydraulic Filter Group	5-42		
Fig. 26 - Hydraulic Couplings Group	5-43		
Fig. 27 - Engine Group	5-44		
Fig. 28 - Sheaves and Belts Group	5-46		
Fig. 29 - Air Cleaner Group	5-47		
Fig. 30 - Flywheel Housing and Coupling Group	5-48		
Fig. 31 - Directional Control Group	5-50		
Fig. 32 - Throttle Linkage Group	5-51		

NOTE: Section 5, Low Dump Model Parts, lists every repair part of a gasoline powered, low dump, Model 275. This section also contains parts common to all models of the 275.

ORDERING REPAIR PARTS

The components used in this machine have been carefully selected for performance and safety. Use only Tennant Company specified or equivalent parts.

To receive prompt service in filling of your parts orders, please direct all orders for parts with Tennant Company part numbers to the Tennant Company, and all orders for parts with vendor part numbers to the local supplier of the respective vendor.

When ordering parts, please furnish all of the following information:

1. Machine model number - shown on the machine data plate.

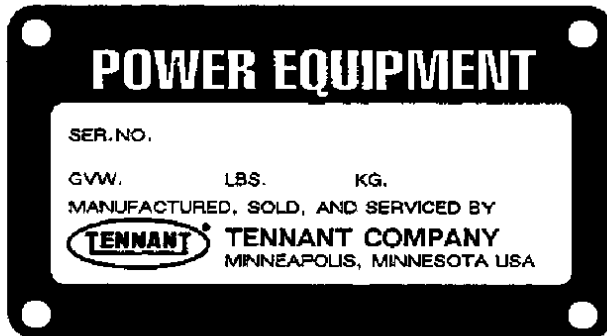

2. Machine serial number - shown on the machine data plate.
3. Power source - gasoline, LPG, diesel, electric.
4. Company name.
5. Shipping address.
6. Billing address.
7. Name, first and last - of person ordering parts.
8. Telephone number.
9. Purchase order number.
10. Part number, description, and quantity - of each item on the order.

Do not order parts by key number or the figure number of the illustrated parts. Indented items indicate parts of assemblies. Standard hardware is furnished only when part of a purchased assembly. Please get hardware from a local hardware supplier.

If the old part cannot be identified, send it to us with the quantity needed specified on the order.

Any claim for loss or damage to a shipment in transit should be filed promptly against the transportation company making the delivery. Shipments will be complete unless the packing list or order acknowledgement indicate items back ordered.

If parts received are suspected to be incorrect or defective, please write, wire, or phone the Tennant Company representative from whom you ordered the part. They will give authorization for return and/or handle replacement shipments when required.

SERIAL NUMBER INFORMATION EXPLANATION

Serial number listings are shown to indicate on which machines each part can be used. These listings are explained by the following examples:

(000000-) The part can be used on all machines.

(003342-) The part can be used on all machines beginning with the serial number listed.

(000000-004320) The part can be used on all machines up to and including serial number listed.

(004321-005678) The part can be used on all machines between and including the serial numbers listed.

Where xxxxx's are listed in place of a serial number, it indicates a change was made but the exact serial number had not been established when the catalog went to press.

SI UNITS OF MEASURE (INTERNATIONAL SYSTEM)

Metric equivalents have been included, where applicable, throughout this parts catalog.

FASTENER STRENGTH IDENTIFICATION

Fasteners required to have high-strength qualities equivalent to SAE Grade 8 are identified throughout this catalog by the description GR 8. Unless identified by this description, all standard fasteners are SAE Grade 5.

(Specifications and design subject to change without notice.)

Fig. 1 - Recommended General Maintenance Items

02585

Key	Tennant® Part No.	Machine Serial Number	Description	Qty.
	82050	(000000-)	Maintenance Kit, 400 Hour, Gasoline	1
	45770-8	(000000-)	Spark Plug	4
	82525	(000000-)	Filter, Fuel	1
	58506	(000000-)	Points Set	1
	58509	(000000-)	Condenser	1
	82697	(000000-)	Rotor, Overspeed Protection	1
	58507	(000000-)	Cap, Distributor	1
	54911-24	(000000-)	Gasket, Valve Cover	1
	38245	(000000-)	Valve, PCV	1
	58120	(000000-)	Filter, Air	1
	58122	(000000-)	Filter, Oil	8
	32397-1	(000000-)	Hydraulic Fluid, HP1040, 1 Gal (3.8 L)	6
	55740	(000000-)	Filter, Hydraulic	1
	82051	(000000-)	Maintenance Kit, 400 Hour, LPG	1
	SK1444	(000000-)	Repair Kit, Fuel Filter Lock	1
	45770-8	(000000-)	Spark Plug	4
	58506	(000000-)	Points Set	1
	58509	(000000-)	Condenser	1
	82697	(000000-)	Rotor, Overspeed Protection	1
	58507	(000000-)	Cap, Distributor	1
	54911-24	(000000-)	Gasket, Valve Cover	1
	38245	(000000-)	Valve, PCV	1
	58120	(000000-)	Filter, Air	1
	58122	(000000-)	Filter, Oil	8
	32397-1	(000000-)	Hydraulic Fluid, HP1040, 1 Gal (3.8 L)	6
	55740	(000000-)	Filter, Hydraulic	1
	82054	(000000-)	Maintenance Kit, 400 Hour, Diesel	1
	58120	(000000-)	Filter, Air	1
	58121	(000000-)	Filter, Air Safety	1
	82693	(000000-)	Filter, Oil	8
	82692	(000000-)	Filter, Fuel	1
	55740	(000000-)	Element, Hydraulic Filter	1
	32397-1	(000000-)	Hydraulic Fluid, HP1040, 1 Gal (3.8 L)	6
	82058	(000000-)	Maintenance Kit, Skirts, Low Dump	1
	23275	(000000-)	Skirt, Shroud	2
	45857	(000000-)	Strip, Skirt Retainer	2
	53298	(000000-)	Skirt	1
	82163	(000000-)	Angle, Mounting Skirt	1
	82164	(000000-)	Skirt	1
	82165	(000000-)	Strip	1
	02485	(000000-)	Nut, Retainer	7
	23382	(000000-)	Seal, Side	2
	23384-2	(000000-)	Strip	2
	23386	(000000-)	Seal, Top	1
	50446	(000000-)	Retainer, Hopper Top Seal	1
	82799	(000000-)	Seal, Dust	1
	53489	(000000-)	Strip	2
	48060	(000000-)	Lip, Rubber	5
	46080	(000000-)	Angle, Backing	1

Key	Tennant® Part No.	Machine Serial Number	Description	Qty.
	82059	(000000-)	Maintenance Kit, Seals, Low Dump	1
	82125	(000000-)	Seal, Foam Rubber	2
	53906	(000000-)	Seal, Brush Wrap	3
	47037	(000000-)	Adhesive, Contact Cement	2
	53974	(000000-)	Seal, Foam Rubber	2
	53052	(000000-)	Seal, Foam Rubber	2
	53461-1	(000000-)	Seal, Foam Rubber	2
	53461-2	(000000-)	Seal, Foam Rubber	2
	82415	(000000-)	Seal, Hopper Cover	2
	82416	(000000-)	Seal, Hopper Cover	2
	82741	(000000-)	Seal, Hopper Dust Tube	1
	82466	(000000-)	Seal, Hopper Dust Tube, Outer	1
	82424	(000000-)	Seal, Vacuum Fan Muffler	1
	82048	(000000-)	Maintenance Kit, Skirts, Multi-level Dump	1
	23275	(000000-)	Skirt, Shroud	2
	45857	(000000-)	Strip, Skirt Retainer	2
	53298	(000000-)	Skirt	1
	82163	(000000-)	Angle, Mounting Skirt	1
	82164	(000000-)	Skirt	1
	82165	(000000-)	Strip	1
	02485	(000000-)	Nut, Retainer	7
	23382	(000000-)	Seal, Side	2
	23384-2	(000000-)	Strip	2
	23386	(000000-)	Seal, Top	1
	50446	(000000-)	Retainer, Hopper Top Seal	1
	82799	(000000-)	Seal, Dust	1
	53489	(000000-)	Strip	2
	35607	(000000-)	Lip	5
	53758	(000000-)	Strip	1
	37021	(000000-)	Lip, Side	2
	82049	(000000-)	Maintenance Kit, Seals, Multi-level Dump	1
	82125	(000000-)	Seal, Foam	2
	53906	(000000-)	Seal, Brush Wrap	3
	47037	(000000-)	Adhesive, Contact Cement	2
	53974	(000000-)	Seal, Foam Rubber	2
	53052	(000000-)	Seal, Foam Rubber	2
	54338-6	(000000-)	Seal, Foam Rubber	2
	37054	(000000-)	Seal, Foam Rubber	2
	37055	(000000-)	Seal, Foam Rubber	2
	82415	(000000-)	Seal, Hopper Cover	2
	82416	(000000-)	Seal, Hopper Cover	2
	82424	(000000-)	Seal, Vacuum Fan Muffler	1
	82425	(000000-)	Seal, Vacuum Fan Inlet	1



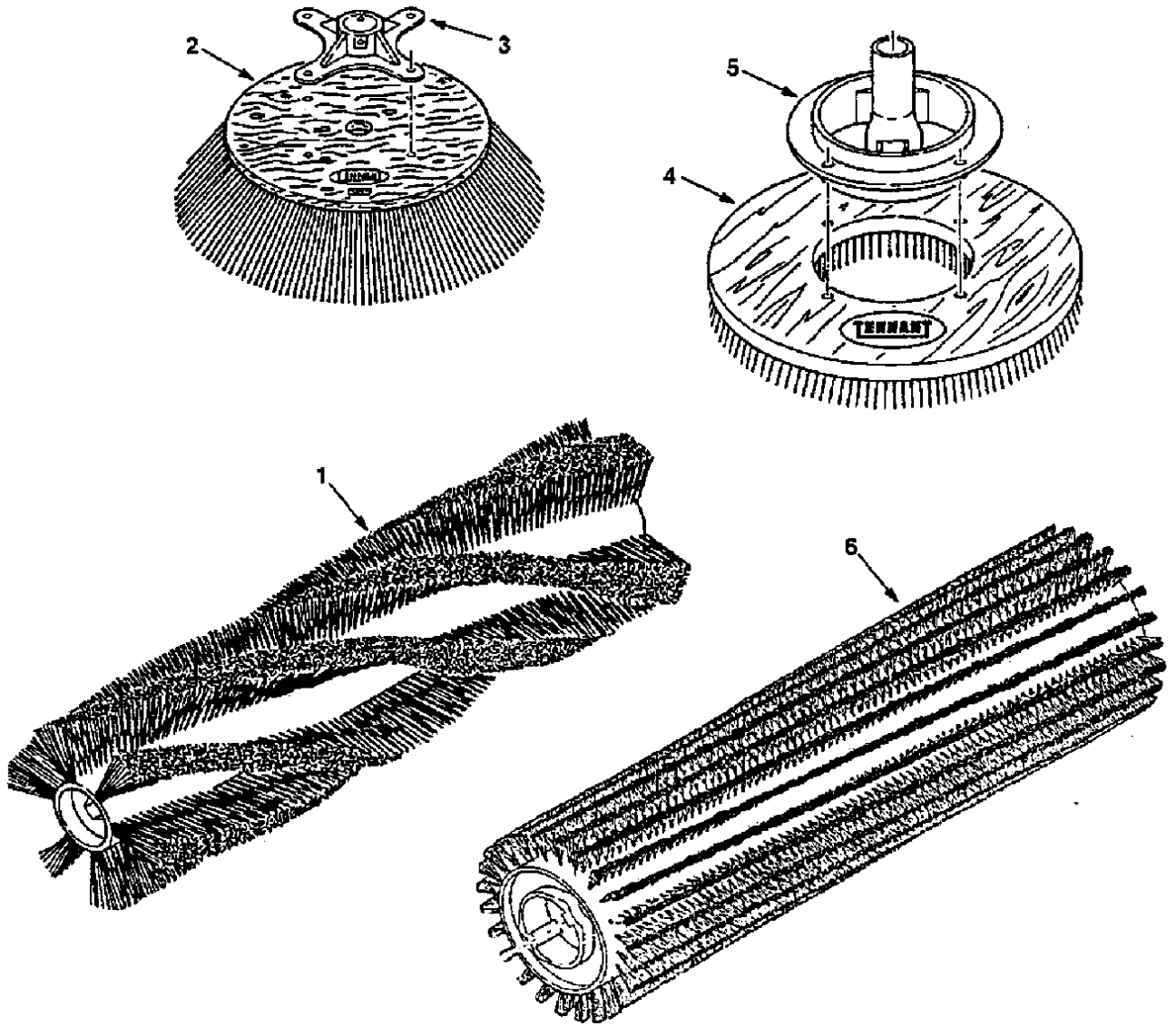

Fig. 2 - Replacement Brushes

Fig. 2 - Replacement Brushes

02794

Key	Tennant® Part No.	Machine Serial Number	Description	Qty.
1	24741	(000000-)	Main Brush, Snow	1
1	53063	(000000-)	Main Brush, 24 Row Wire and Fiber	1
1	53065	(000000-)	Main Brush, 8 Row Wire	1
1	53067	(000000-)	Main Brush, 8 Row Wire and Fiber	1
1	53068	(000000-)	Main Brush, 8 Row Nylon	1
1	53069	(000000-)	Main Brush, 5 Row Nylon	1
1	53070	(000000-)	Main Brush, 24 Row Nylon	1
1	53221	(000000-)	Main Brush, 8 Row Wire and Fiber	1
1	53231	(000000-)	Main Brush, 8 Row Polypropylene	1
	43708P	(000000-)	Side Brush Assembly, Polypropylene	1
2	09600P	(000000-)	Side Brush, Polypropylene	1
3	47501	(000000-)	Hub, Brush Adaptor	1
	43708N	(000000-)	Side Brush Assembly, Nylon	1
	09600N	(000000-)	Side Brush, Nylon	1
	47501	(000000-)	Hub, Brush Adaptor	1
	43708K	(000000-)	Side Brush Assembly, Flat Wire	1
	10712K	(000000-)	Side Brush, Flat Wire	1
	47501	(000000-)	Hub, Brush Adaptor	1
	46857	(000000-)	Side Brush Assembly, Scrub, Polypropylene	1
4	43148	(000000-)	Side Brush, Scrub, Polypropylene	1
5	43554	(000000-)	U-Joint, Side Brush Drive	1
	46858	(000000-)	Side Brush Assembly, Scrub, Polypropylene	1
	43593	(000000-)	Side Brush, Scrub, Polypropylene	1
	43554	(000000-)	U-Joint, Side Brush Drive	1
	46859	(000000-)	Side Brush Assembly, Scrub, Stainless Steel	1
	43417	(000000-)	Side Brush, Scrub, Stainless Steel	1
	43554	(000000-)	U-Joint, Side Brush Drive	1
6	43424	(000000-)	Scrub Brush, 24 Row Polypropylene	1
6	43428	(000000-)	Scrub Brush, 20 Row Stainless Steel	1
6	43592	(000000-)	Scrub Brush, 24 Row Polypropylene	1
6	43680	(000000-)	Scrub Brush, 24 Row Abrasive	1

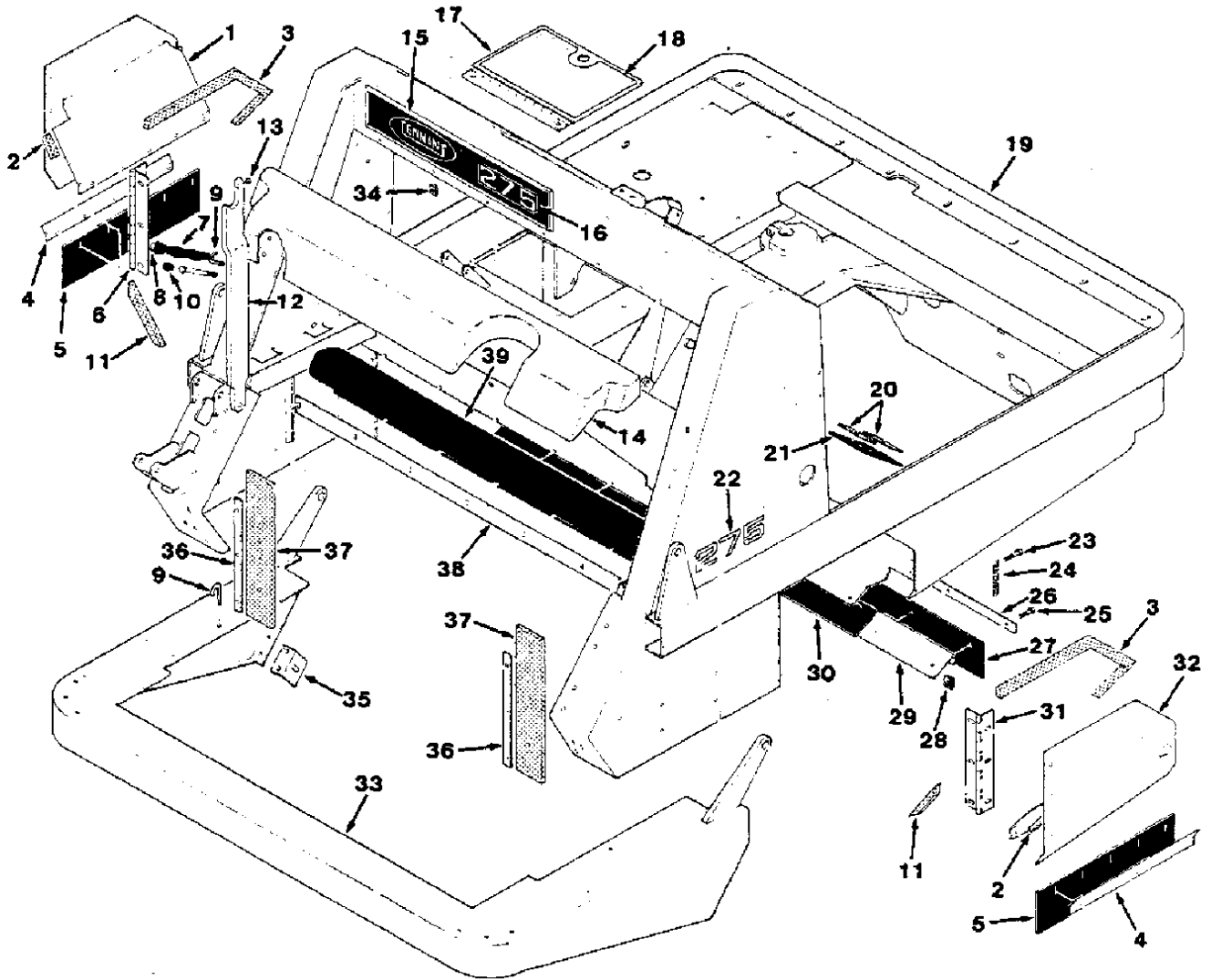

Fig. 3 - Main Frame Group

Fig. 3 - Main Frame Group

02711

Key	Tennant® Part No.	Machine Serial Number	Description	Qty.
1	33762	(000000-)	Door, Brush, R.H.	1
2	82125	(000000-)	Seal, Foam Rubber	2
3	53052	(000000-)	Seal, Foam Rubber	2
4	45857	(000000-)	Strip, Skirt Retainer	2
5	23275	(000000-)	Skirt, Shroud	2
6	32885	(000000-)	Hinge, Door, R.H.	1
7	46567	(000000-)	Tube, Chain Cover	1
8	46307	(000000-)	Chain	1
9	02943	(000000-)	Bolt, J	2
10	01318	(000000-)	Tip, Rubber	1
11	53974	(000000-)	Seal, Foam Rubber	2
12	82190	(000000-)	Arm Assembly, Hopper Stop	1
13	16786	(000000-)	Bumper, Rubber	1
14	02998	(000000-)	Panel, Filler	1
15	57815	(000000-)	Plate, Front Logo	1
16	82719	(000000-)	Plate, Numbers	1
17	53465-2	(000000-)	Cover, Battery	1
18	32270	(000000-)	Tread, Floor	1
19	82140	(000000-)	Frame, Main	1
20	53489	(000000-)	Strip	2
21	82799	(000000-)	Seal, Dust	1
22	82657	(000000-)	Label, 275	1
23	34196	(000000-)	Screw, Hex, Nylon	1
24	09342	(000000-)	Chain, Static	1
25	34292	(000000-)	Screw, Hex, Nylon	6
26	82165	(000000-)	Strip	1
27	82164	(000000-)	Skirt	1
28	02485	(000000-)	Nut, Retainer	7
29	82163	(000000-)	Angle, Skirt Mounting	1
30	53298	(000000-)	Skirt	1
31	32886	(000000-)	Hinge, Door, L.H.	1
32	33760	(000000-)	Door, Brush, L.H.	1
33	03021	(000000-)	Bumper Assembly	1
34	82138	(000000-)	Nut, Speed	2
35	82189	(000000-)	Bracket, L	2
36	23384-2	(000000-)	Strip	2
37	23382	(000000-)	Seal, Side	2
38	53143	(000000-)	Strip	1
39	23386	(000000-)	Seal, Top	1

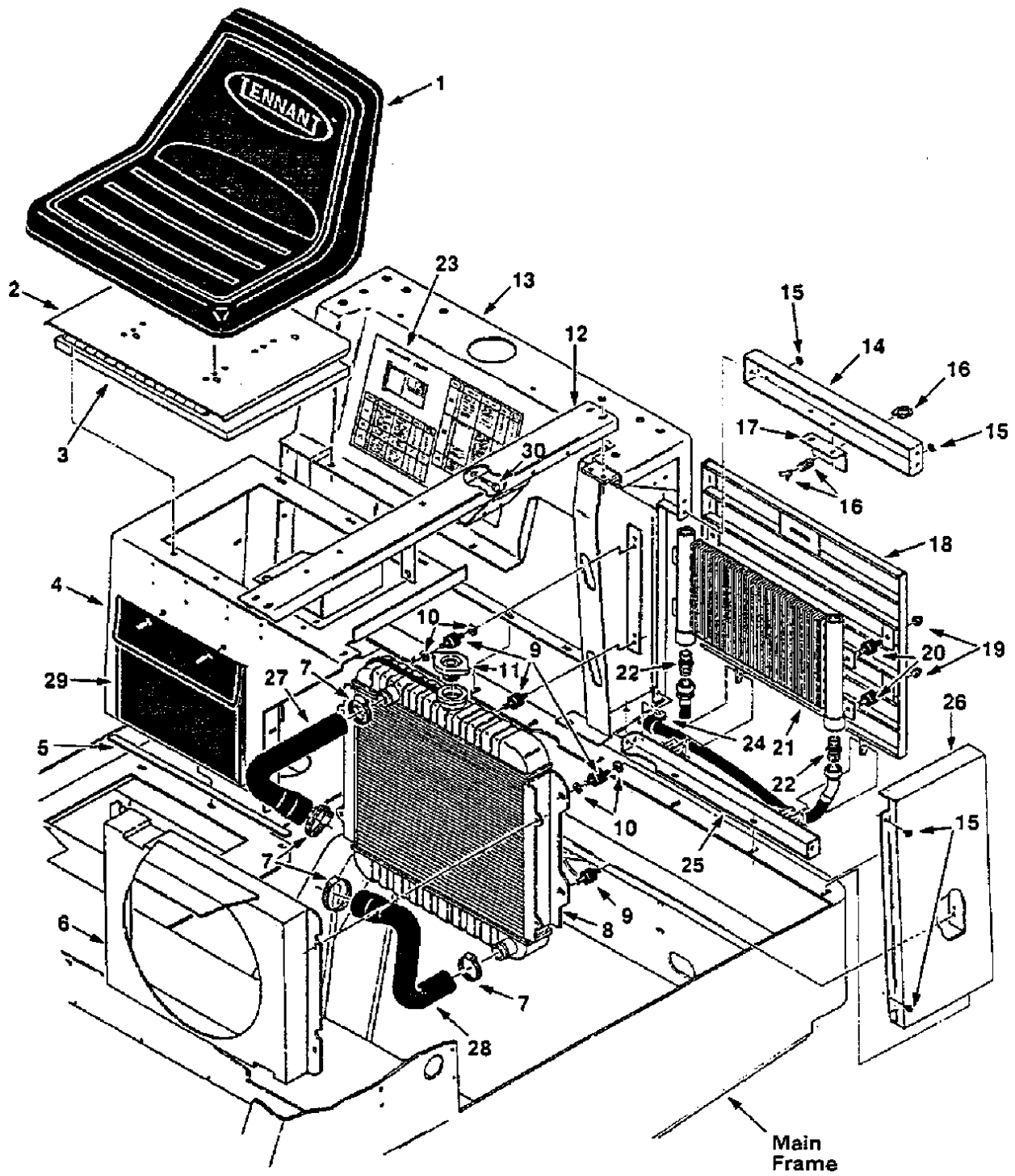

Fig. 4 - Seat and Radiator Group

Fig. 4 - Seat and Radiator Group

02560

Key	Tennant® Part No.	Machine Serial Number	Description	Qty.
1	82342	(000000-)	Seat	1
2	82346	(000000-)	Mount, Seat	1
3	82300	(000000-)	Foam, Acoustic	1
4	82321	(000000-)	Support, Front Seat	1
5	23826	(000000-)	Seal, Support	1
6	82192	(000000-)	Shroud Assembly, Fan	1
7	11531	(000000-)	Clamp, Worm Drive	4
8	58299	(000000-)	Radiator	1
9	82661	(000000-)	Isolator, Vibration	4
10	82662	(000000-)	Spacer	4
11	51321-3	(000000-)	Cap, Radiator	1
12	82768	(000000-)	Support, Valve	1
13	82320	(000000-)	Support, Rear Seat	1
14	82313	(000000-)	Channel, Stiffener	1
15	29233	(000000-)	Bumper, Rubber	4
16	82315	(000000-)	Latch, Quarter Turn	1
17	82311	(000000-)	Bracket, Latch	1
18	82310	(000000-)	Grille	1
19	41128	(000000-)	Nut, Low Crown	4
20	51322	(000000-)	Isolator, Vibration	4
21	82798	(000000-)	Cooler, Hydraulic	1
22	42260	(000000-)	Fitting, Straight	2
23	82722	(000000-)	Label, Maintenance Chart	1
24	58366	(000000-)	Clamp, Support	1
25	82314	(000000-)	Channel, Stiffener	1
26	82316	(000000-)	Panel, Corner	1
27	82588	(000000-)	Hose, Radiator	1
28	82515	(000000-)	Hose, Radiator	1
29	68275	(000000-)	Pouch, Operator's Manual	1
30	34323	(000000-)	Screw, Hex, Nylon	4

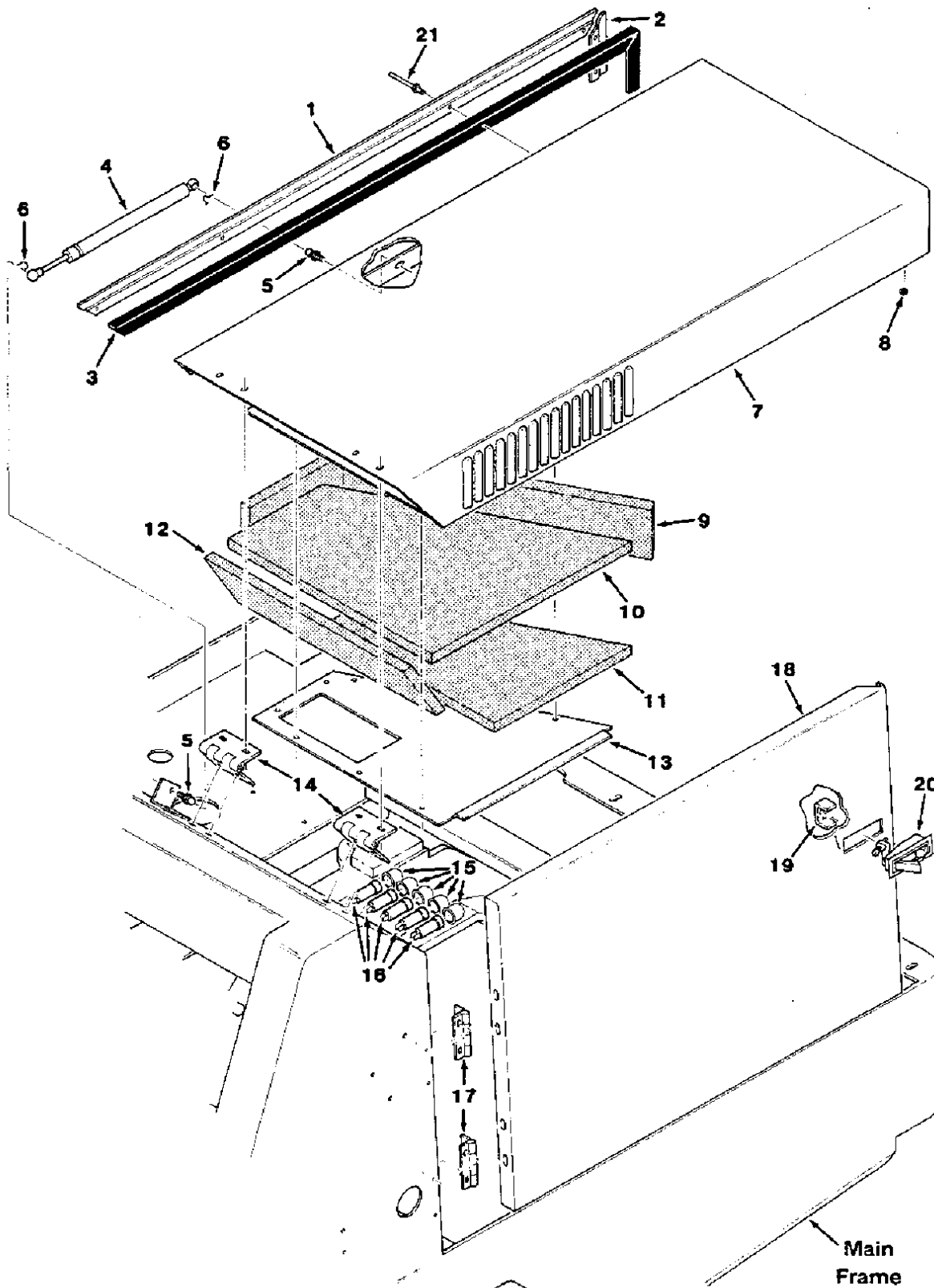

Fig. 5 - Engine Cover and Side Door Group

Fig. 5 - Engine Cover and Side Door Group

02551

Key	Tennant® Part No.	Machine Serial Number	Description	Qty.
1	82377	(000000-)	Retainer, Seal	1
2	82378	(000000-)	Retainer, Seal	1
3	82379	(000000-)	Seal, Engine Cover	1
4	82334	(000000-)	Spring, Gas	1
5	58494	(000000-)	Stud, Ball	2
6	64595	(000000-)	Clip, Safety	2
7	82319	(000000-)	Cover, Engine	1
8	51787	(000000-)	Bumper, Rubber	2
9	82350	(000000-)	Insulation, Foam	1
10	82338	(000000-)	Insulation, Foam	1
11	82352	(000000-)	Insulation, Foam	1
12	82351	(000000-)	Insulation, Foam	1
13	82324	(000000-)	Plate, Chamber	1
14	82348	(000000-)	Hinge	2
15	57751	(000000-)	Boot, Breaker	5
16	57803	(000000-)	Breaker, Circuit	5
17	47692	(000000-)	Hinge	2
18	82234	(000000-)	Panel, Side Door	1
19	57298	(000000-)	Bracket, Latch	1
20	64533	(000000-)	Latch, Trigger	1
21	34738	(000000-)	Rivet	6

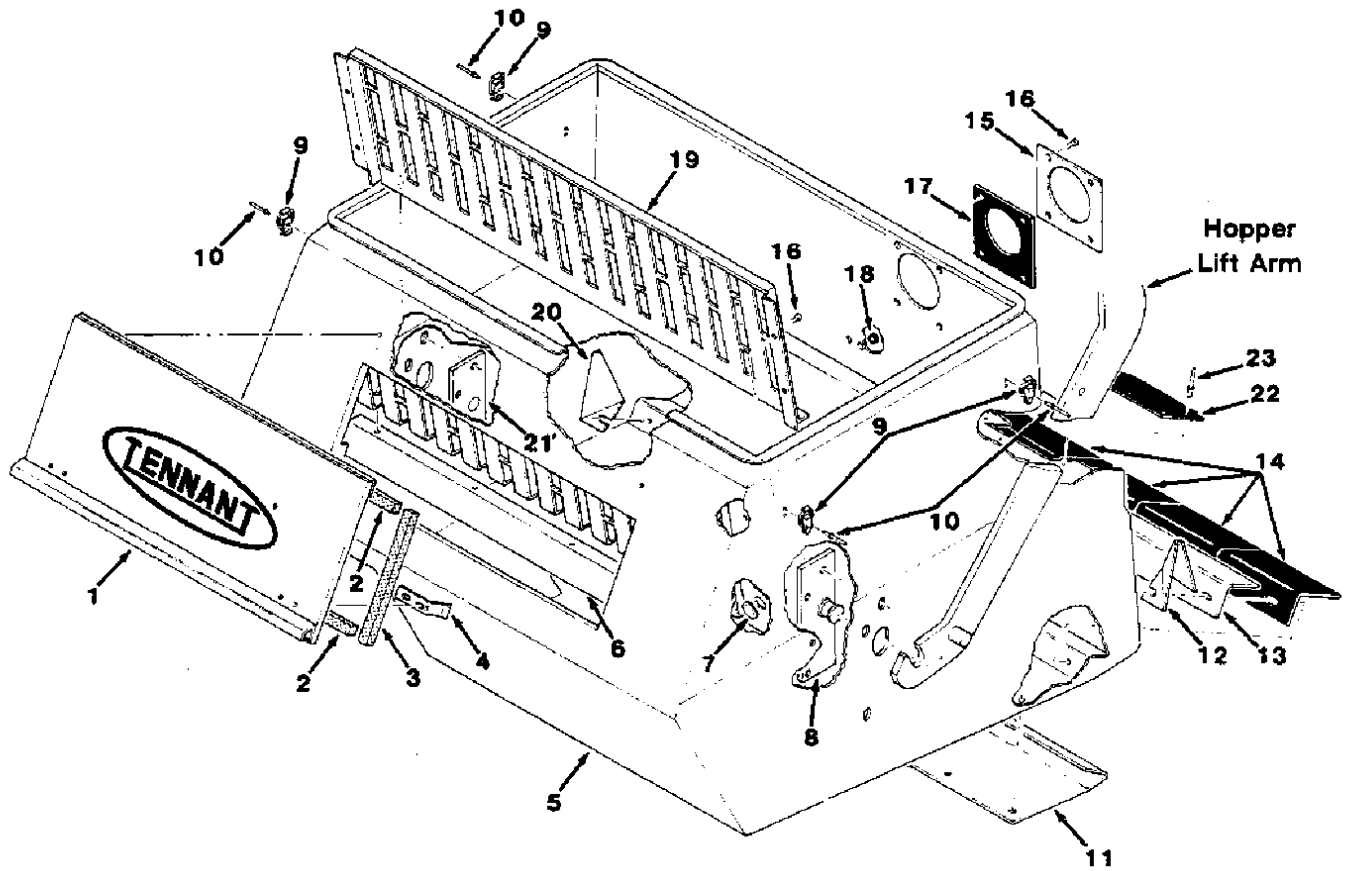

Fig. 6 - Hopper Group

Fig. 6 - Hopper Group

02703

Key	Tennant® Part No.	Machine Serial Number	Description	Qty.
1	53462	(000000-)	Door, Hopper	1
2	53461-2	(000000-)	Seal, Foam Rubber	2
3	53461-1	(000000-)	Seal, Foam Rubber	2
4	53697	(000000-)	Catch, Spring	2
5	82411	(000000-)	Hopper	1
6	82468	(000000-)	Deflector	1
7	47178-2	(000000-)	Plugbutton	1
8	24096	(000000-)	Support, L.H.	1
9	37083-1	(000000-)	Catch	4
10	34738	(000000-)	Rivet	8
11	46077	(000000-)	Plate	1
12	46596	(000000-)	Deflector, L.H.	1
13	46080	(000000-)	Angle, Backing	1
14	48060	(000000-)	Lip, Rubber	5
15	82467	(000000-)	Plate, Retaining	1
16	58670	(000000-)	Screw, Hex, Nylon	13
17	82466	(000000-)	Seal, Tube	1
18	47178-3	(000000-)	Plugbutton	1
19	82469	(000000-)	Baffle, Inner	1
20	46595	(000000-)	Deflector, R.H.	1
21	24097	(000000-)	Support, R.H.	1
22	02886	(000000-)	Seal, Hopper	1
23	56799	(000000-)	Rivet	5

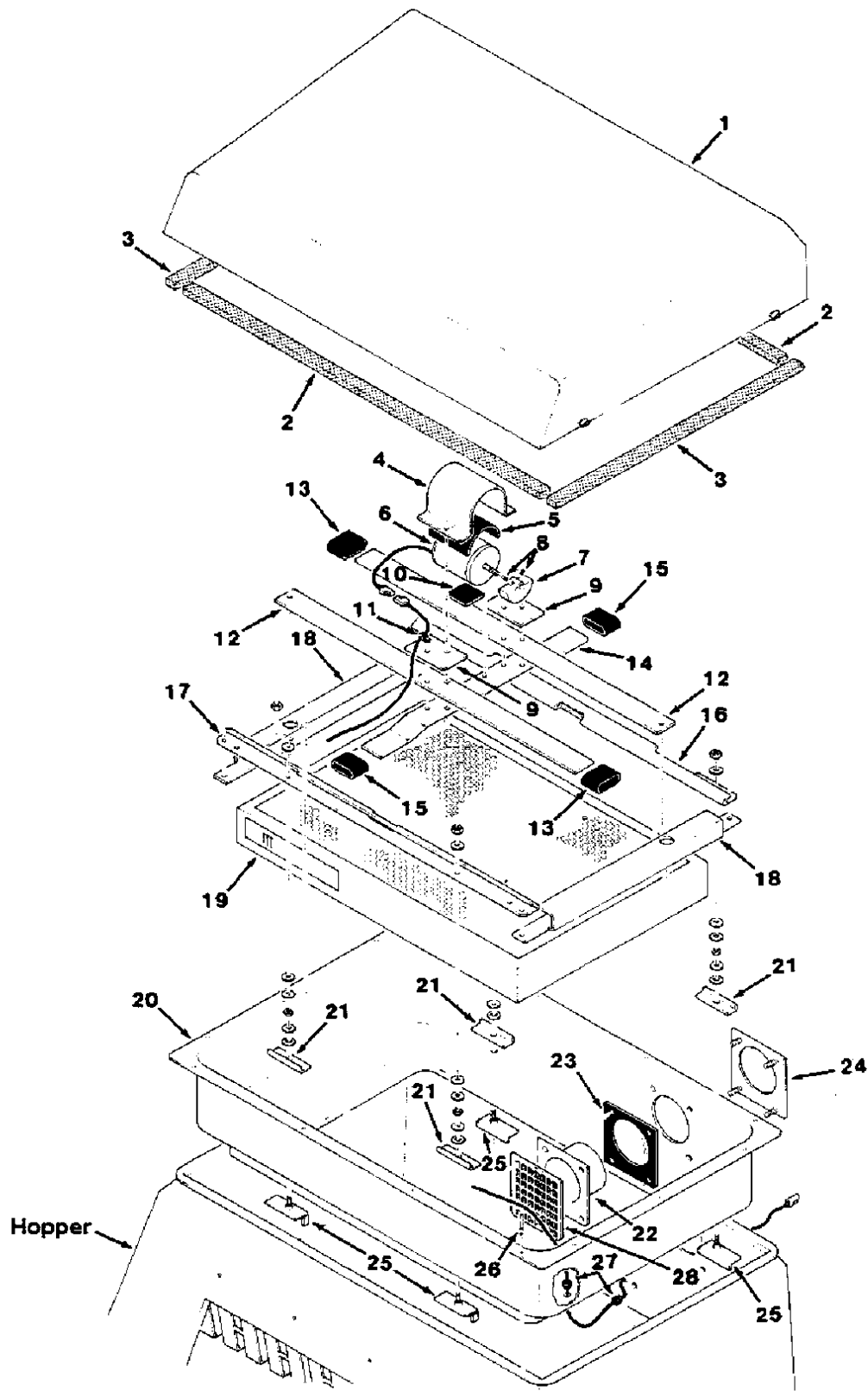

Fig. 7 - Hopper Cover and Filter Shaker Group

Fig. 7 - Hopper Cover and Filter Shaker Group

02558

Key	Tennant® Part No.	Machine Serial Number	Description	Qty.
1	82407	(000000-)	Cover, Hopper	1
2	82416	(000000-)	Seal	2
3	82415	(000000-)	Seal	2
4	36666	(000000-)	Strap, Shaker Motor	1
5	36658	(000000-)	Pad, Rubber	1
6	54121	(000000-)	Motor, Shaker	1
7	55130	(000000-)	Weight, Eccentric	1
8	39319	(000000-)	Screw, Set	2
9	82475	(000000-)	Bar, Shaker	2
10	36661	(000000-)	Pad, Rubber	2
11	46236	(000000-)	Clamp, Cable	1
12	58482	(000000-)	Spring, Shaker	2
13	36663	(000000-)	Sleeve, Rubber	2
14	58483	(000000-)	Bar, Shaker	1
15	36665	(000000-)	Sleeve, Rubber	2
16	82455	(000000-)	Bracket, Retaining	1
17	82452	(000000-)	Bracket, Retaining	1
18	82453	(000000-)	Bracket, Retaining	2
19	58476	(000000-)	Element, Air Filter	1
20	82460	(000000-)	Carrier, Filter	1
21	82472	(000000-)	Bracket	4
22	82461	(000000-)	Tube, Duct	1
23	82471	(000000-)	Seal, Tube	1
24	82465	(000000-)	Plate, Tube	1
25	82504	(000000-)	Bracket Assembly, Mounting	4
26	82457	(000000-)	Rivet, Steel	14
27	47591	(000000-)	Strain Relief	2
28	82514	(000000-)	Screen, Inlet	1

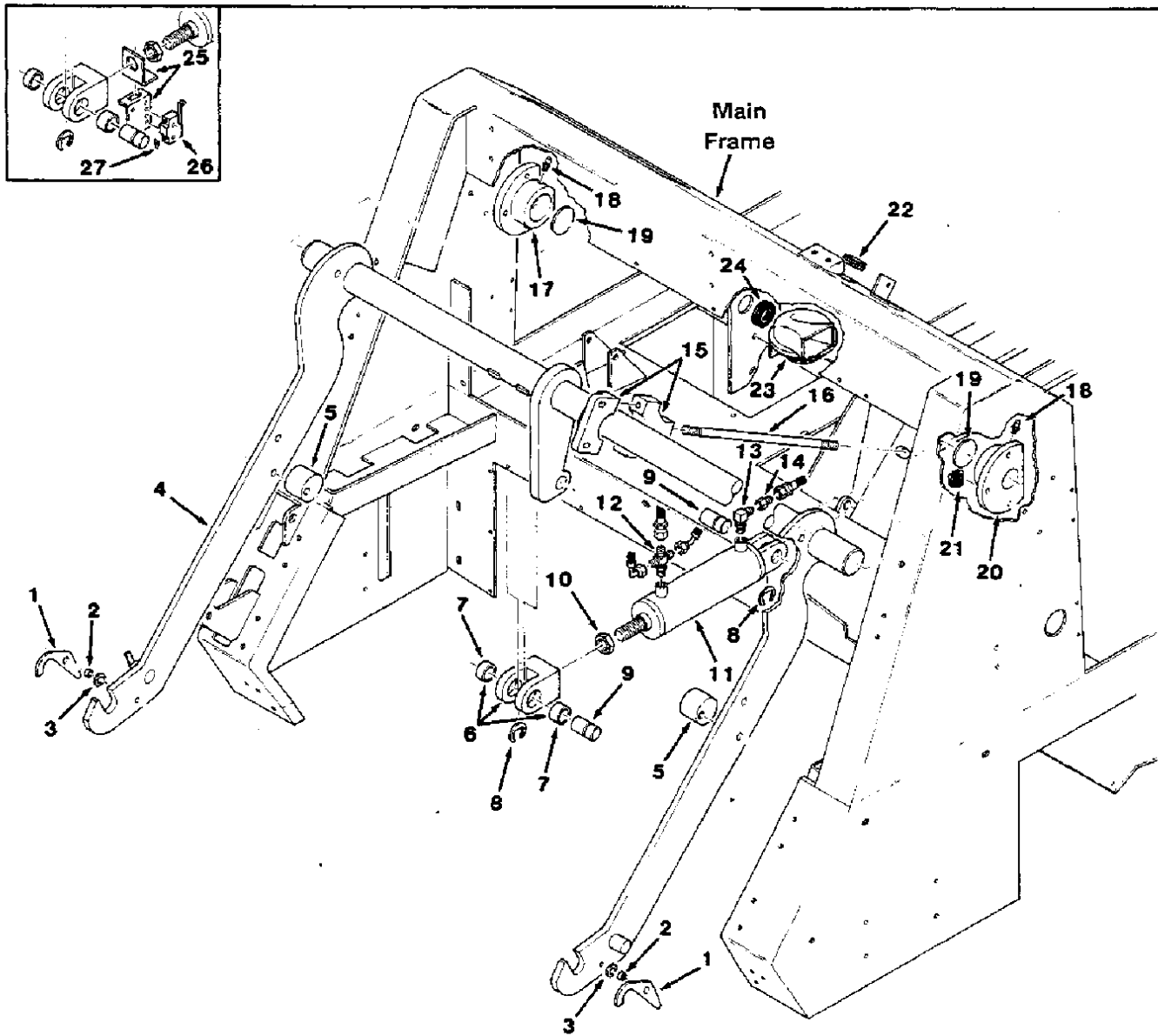

Fig. 8 - Hopper Lift Arms Group

Fig. 8 - Hopper Lift Arms Group

02552

Key	Tennant® Part No.	Machine Serial Number	Description	Qty.
1	46132	(000000-)	Hook	2
2	46137	(000000-)	Sleeve	2
3	46147	(000000-)	Washer, Neoprene	2
4	82191	(000000-)	Arm Assembly, Lift	1
5	23452-2	(000000-)	Cam	2
6	32942	(000000-)	Clevis Assembly	1
7	35688	(000000-)	Bearing, Journal	2
8	23788	(000000-)	Ring, Retaining	2
9	32941	(000000-)	Pin, Grooved	2
10	48988	(000000-)	Nut	1
11	82755	(000000-)	Cylinder, Hydraulic	1
12	82802	(000000-)	Fitting, Cross	1
13	77097	(000000-)	Fitting, Elbow	1
14	16456	(000000-)	Fitting, Restrictor	1
15	23580-2	(000000-)	Bearing, Center	1
16	23583-2A	(000000-)	Stud	1
17	23454-2	(000000-)	Bearing, R.H.	1
18	07259	(000000-)	Fitting, Grease	2
19	23138	(000000-)	Shim	6
20	23455-2	(000000-)	Bearing, L.H.	1
21	82829	(000000-)	Clamp, Support	1
22	10632-14	(000000-)	Grommet	1
23	14138A	(000000-)	Horn	1
24	10632-1	(000000-)	Grommet	1
25	82085	(000000-002906)	Replacement Kit, Switch Bracket	1
26	16582	(000000-002906)	Switch, Roller	1
27	68106	(000000-002906)	Terminal, Tab	2

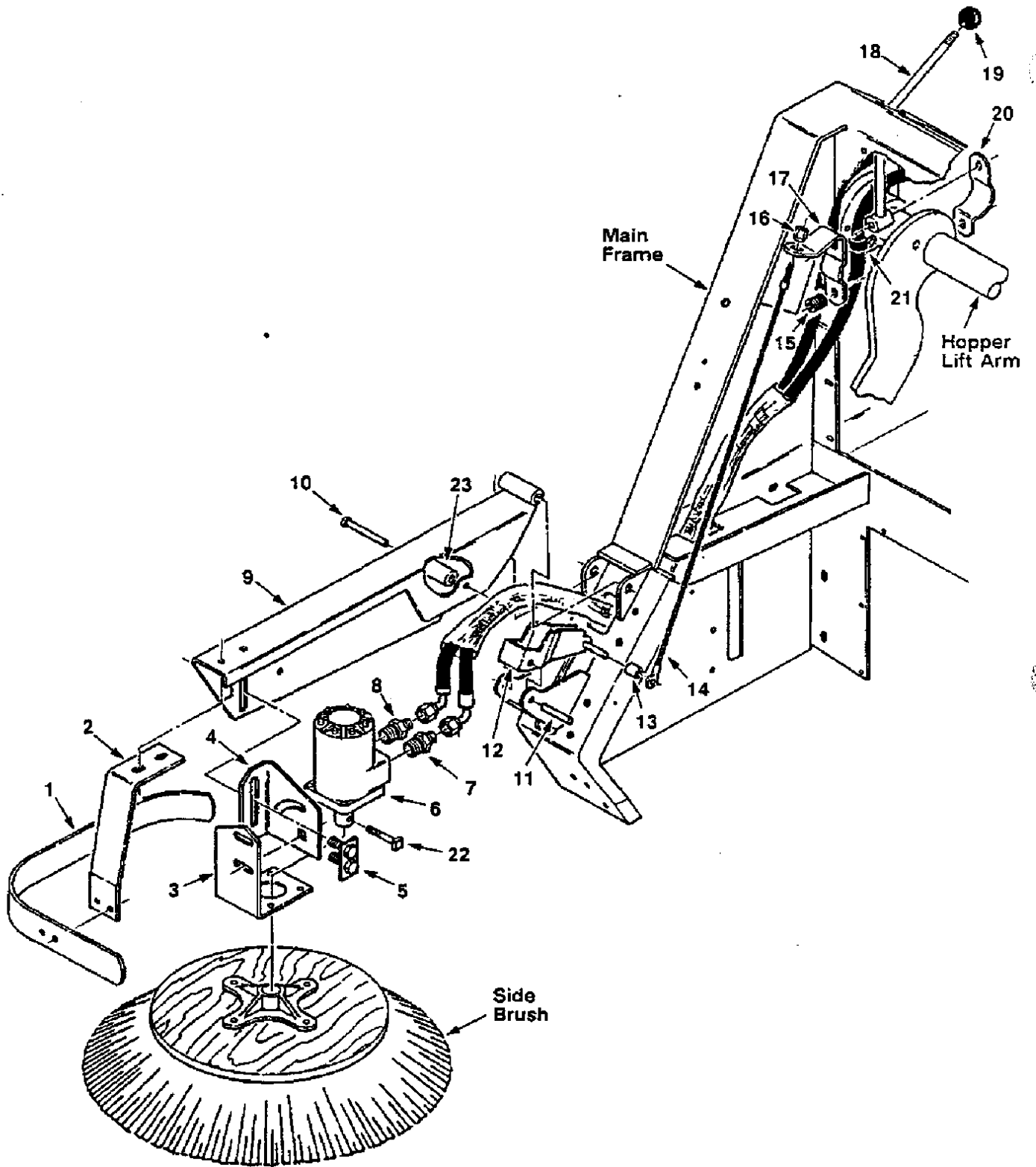

Fig. 9 - Side Brush Group

Fig. 9 - Side Brush Group

02554

Key	Tennant® Part No.	Machine Serial Number	Description	Qty.
1	46034	(000000-)	Bumper, Side Brush	1
2	46033	(000000-)	Support, Bumper	1
3	43228	(000000-)	Bracket, Motor Mounting	1
4	24207	(000000-)	Bracket, Adjustment	1
5	46347	(000000-)	Lug, Side Brush	1
6	82758	(000000-)	Motor, Hydraulic	1
7	57984	(000000-)	Fitting, Straight	1
8	47508	(000000-)	Fitting, Straight	1
9	48062	(000000-)	Arm, Side Brush	1
10	23191	(000000-)	Pin, Clevis	1
11	23536	(000000-)	Pin, Dowel	1
12	23503A	(000000-)	Lever, Lift	1
13	22143	(000000-)	Sleeve	1
14	23294	(000000-)	Cable Assembly	1
15	14174	(000000-)	Spring, Compression	1
16	23293	(000000-)	Nut, Special	1
17	23307-1	(000000-)	Lever, Lift Handle	1
18	82135	(000000-)	Handle, Brush Lift	1
19	26156	(000000-)	Knob	1
20	23306-1	(000000-)	Bracket, Clip	1
21	82829	(000000-)	Clamp, Support	1
22	82250	(000000-)	Screw, Square	1
23	02885	(000000-)	Spacer	1

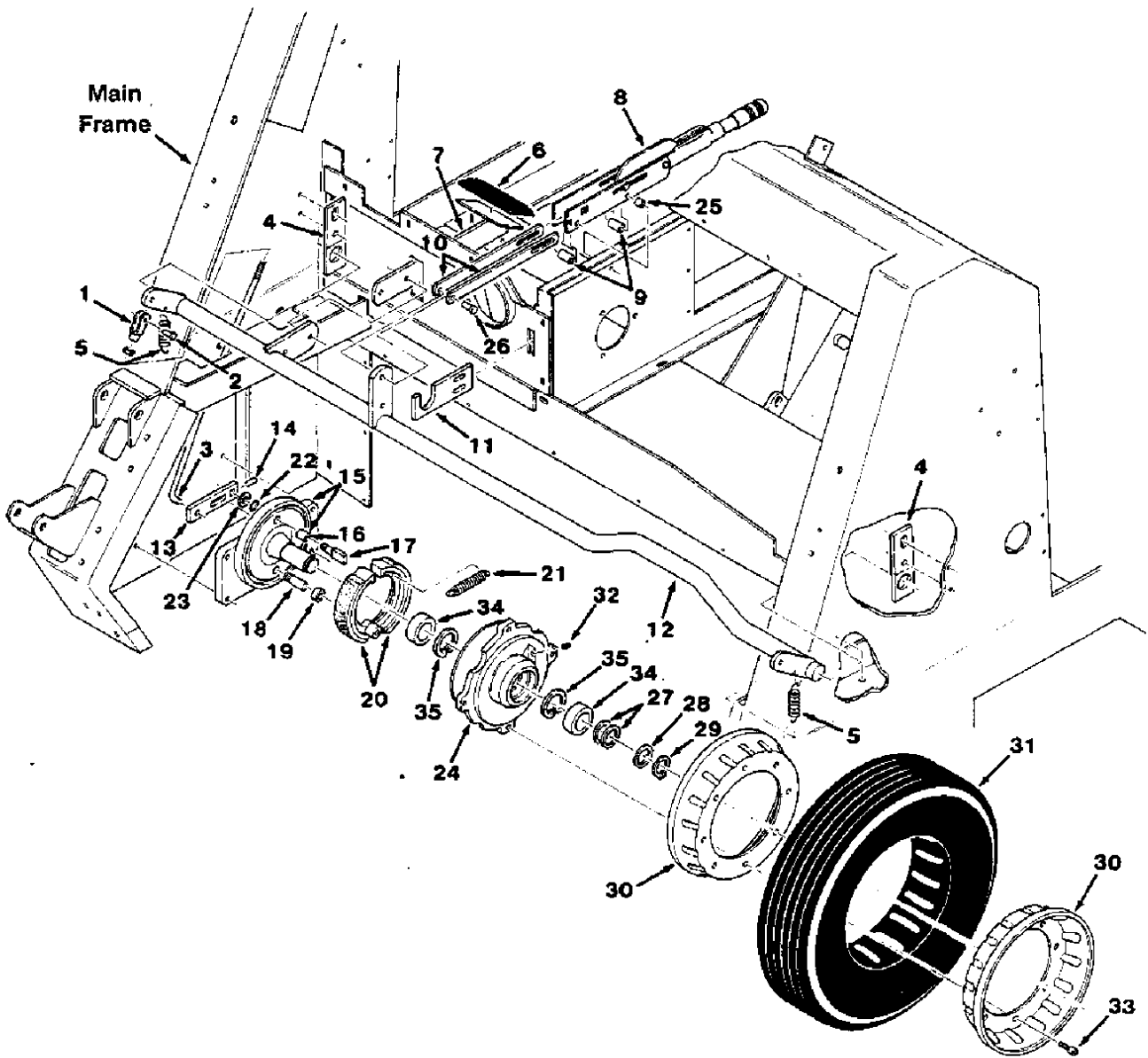

Fig. 10 - Front Wheel and Brakes Group

Fig. 10 - Front Wheel and Brakes Group

02678

Key	Tennant® Part No.	Machine Serial Number	Description	Qty.
1	14595-1	(000000-)	Clevis, Adjustable	2
2	14605	(000000-)	Pin, Clevis	2
3	82218	(000000-)	Rod, Control	2
4	23280-2	(000000-)	Hanger	2
5	03091	(000000-)	Spring, Tension	2
6	51109	(000000-)	Pad	1
7	82244	(000000-)	Arm, Brake Pedal	1
8	51545	(000000-)	Lever, Brake	1
9	51562	(000000-)	Sleeve	2
10	82254	(000000-)	Arm, Extension	2
11	82255	(000000-)	Support, Shaft	1
12	82240	(000000-)	Shaft, Brake	1
	82231	(000000-)	Axle and Brake Assembly, Front	2
13	23484	(000000-)	Arm	1
14	20021	(000000-)	Pin, Roll	1
15	SK2603	(000000-003030)	Replacement Kit, Axle Assembly	1
15	02490	(003031-)	Axle Assembly, Front	1
16	24992	(000000-)	Bushing, Sleeve	1
17	23272	(000000-)	Cam	1
18	10413	(000000-)	Pin	1
19	10415	(000000-)	Sleeve	1
20	10414	(000000-)	Shoe, Brake	2
21	09758	(000000-)	Spring, Tension	1
22	69365-3	(000000-)	O-Ring	1
23	59633	(000000-)	Washer, Thrust	1
24	33815	(000000-)	Hub, Front Wheel	2
25	01275	(000000-)	Sleeve	1
26	69582	(000000-)	Pin, Clevis	1
27	82226	(000000-)	Washer	4
28	82227	(000000-)	Washer	2
29	06442	(000000-)	Ring, Retaining	2
30	23411	(000000-)	Wheel, Half	4
31	47094	(000000-)	Tire, Semi-Pneumatic	2
32	10552	(000000-)	Fitting, Plug	1
33	02985	(000000-)	Screw, Socket	8
34	33816	(000000-)	Bearing, Ball	4
35	23244	(000000-)	Ring, Retaining	4

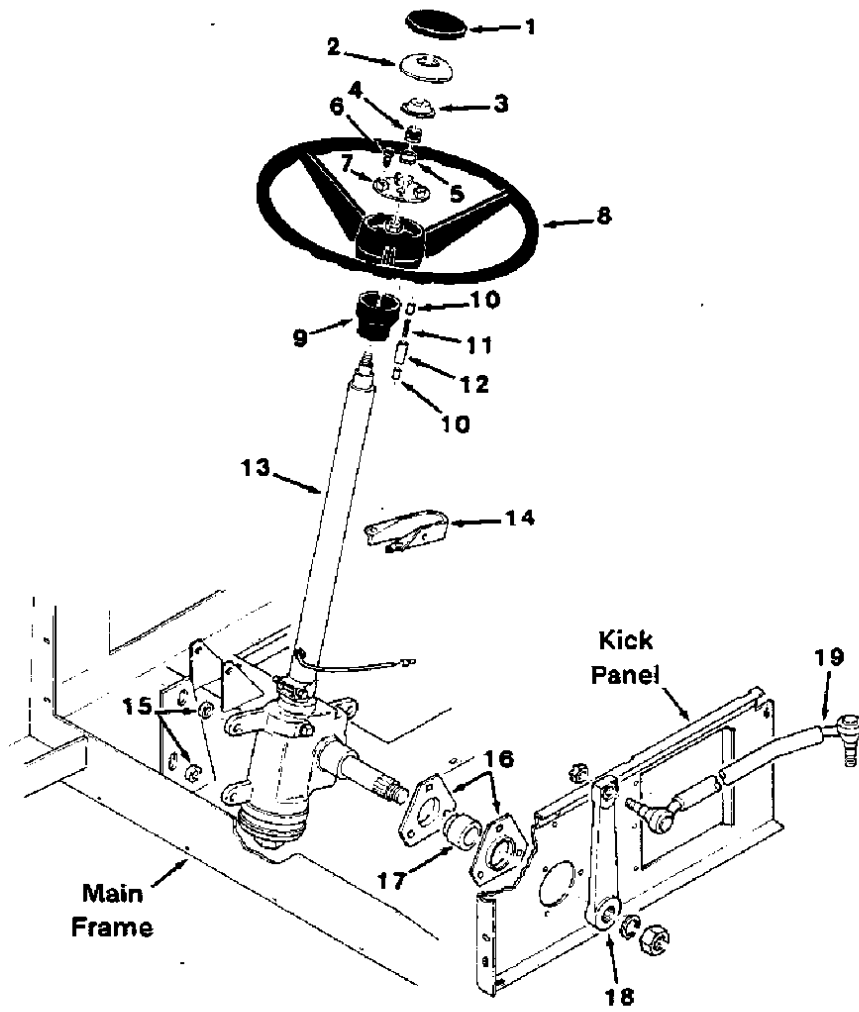

Fig. 11 - Steering Control Group

Fig. 11 - Steering Control Group

02538

Key	Tennant® Part No.	Machine Serial Number	Description	Qty.
1	47010-7	(000000-)	Cover, Horn	1
2	47010-6	(000000-)	Button, Horn	1
3	47010-2	(000000-)	Cup, Contact	1
4	47010-3	(000000-)	Spring, Horn	1
5	47010-1	(000000-)	Cap, Contact	1
6	47010-4	(000000-)	Screw, Wood	3
7	47010-5	(000000-)	Plate Assembly, Base	1
8	82201	(000000-)	Wheel, Steering	1
9	54159	(000000-)	Adaptor, Molded	1
	47011	(000000-)	Horn Brush Unit Assembly	1
10	46311	(000000-)	Brush, Horn	2
11	46313	(000000-)	Spring, Compression	1
12	46312	(000000-)	Tube, Acrylic	1
13	55667	(000000-)	Column Assembly, Steering	1
14	23315-2	(000000-)	Support, Steering Column	1
15	82229	(000000-)	Sleeve	2
16	51449	(000000-)	Flange	2
17	48050-1	(000000-)	Bearing, Ball	1
18	35618	(000000-)	Arm	1
19	53481	(000000-)	Link, Drag	1

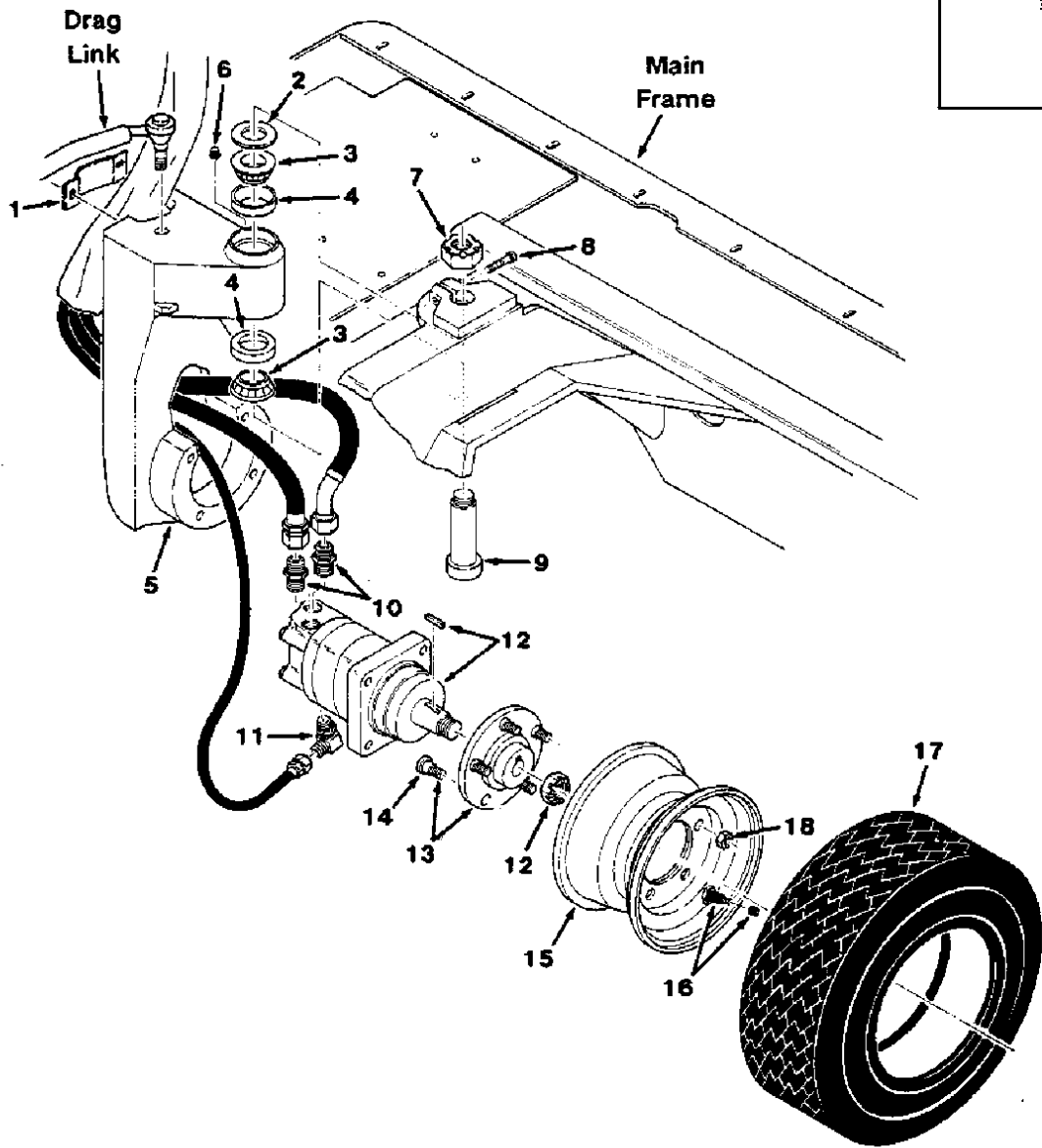

Fig. 12 - Rear Wheel Drive Group

Fig. 12 - Rear Wheel Drive Group

03352

Key	Tennant® Part No.	Machine Serial Number	Description	Qty.
1	82797	(000000-)	Clamp, Hose	1
2	47719	(000000-)	Washer	1
	49225	(000000-)	Bearing, Cone and Cup	1
3	24988	(000000-)	Bearing, Cone	2
4	24989	(000000-)	Bearing, Cup	2
5	82214	(000000-)	Support, Drive	1
6	07259	(000000-)	Fitting, Grease	1
7	14242	(000000-)	Nut, Slotted	1
8	02987	(000000-)	Screw, Socket	1
9	57925	(000000-)	Pin	1
10	06750	(000000-)	Fitting, Straight	2
11	77097	(002230-)	Fitting, Elbow	1
12	82750	(000000-002229)	Motor, Hydraulic, (replaced By 02649)	1
12	02641	(002230-)	Motor, Hydraulic	1
13	82239	(000000-)	Hub and Stud Assembly	1
14	32126	(000000-)	Stud, Wheel	5
	82245	(000000-)	Tire and Wheel Assembly	1
15	82225	(000000-)	Wheel	1
16	75365	(000000-)	Valve, Tire	1
17	47525	(000000-)	Tire	1
18	24339	(000000-)	Nut, Wheel	5
19	82825	(000000-002229)	Fitting, Elbow	1

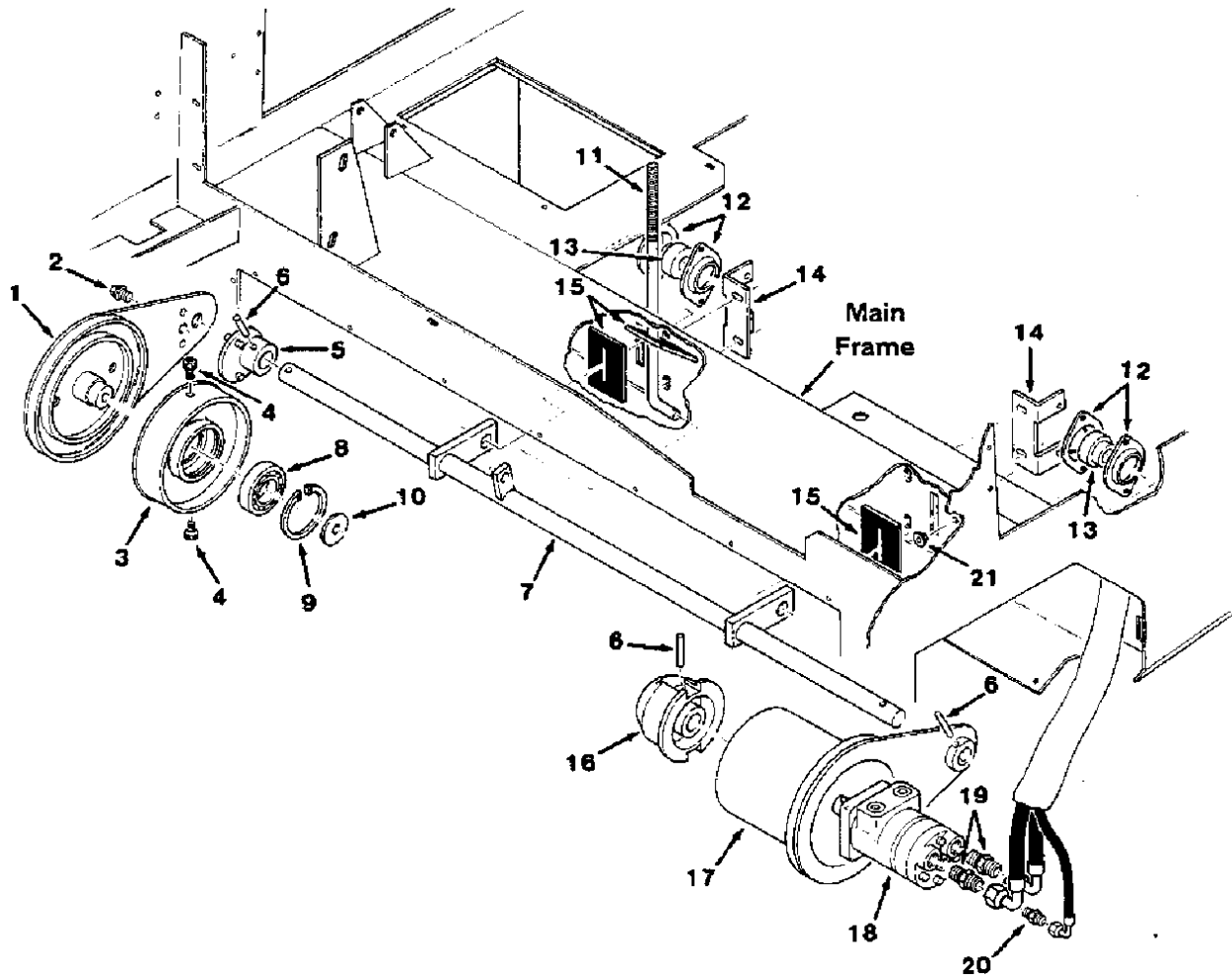

Fig. 13 - Main Brush Drive Group

Fig. 13 - Main Brush Drive Group

03459

Key	Tennant® Part No.	Machine Serial Number	Description	Qty.
1	53168	(000000-)	Arm, Brush, R.H.	1
2	53985	(000000-)	Plug	1
3	51984	(000000-)	Plug, Brush Idler	1
4	02984	(000000-)	Screw, Socket	2
5	02653	(000000-)	Hub, Brush	1
6	20050	(000000-)	Pin, Roll	3
7	35674	(000000-)	Shaft, Counter	1
8	24899	(000000-)	Bearing, Ball	1
9	51046	(000000-)	Ring, Retaining	1
10	51564	(000000-)	Washer	1
11	35677	(000000-)	Rod, L	1
12	35973	(000000-)	Flange, Bearing	4
13	23624	(000000-)	Bearing and Collar	2
14	50521	(000000-)	Bracket, Countershaft Support	2
15	53906	(000000-)	Seal, Brush Wrap	3
16	51036	(000000-)	Plug, Brush Drive	1
17	53169	(000000-002496)	Arm, Brush, L.H.	1
17	82752	(002497-)	Arm, Brush, L.H.	1
18	34423	(000000-)	Motor, Hydraulic	1
19	44869	(000000-)	Fitting, Straight	2
20	55586	(000000-)	Fitting, Straight	1
21	82169	(000000-)	Plug	4

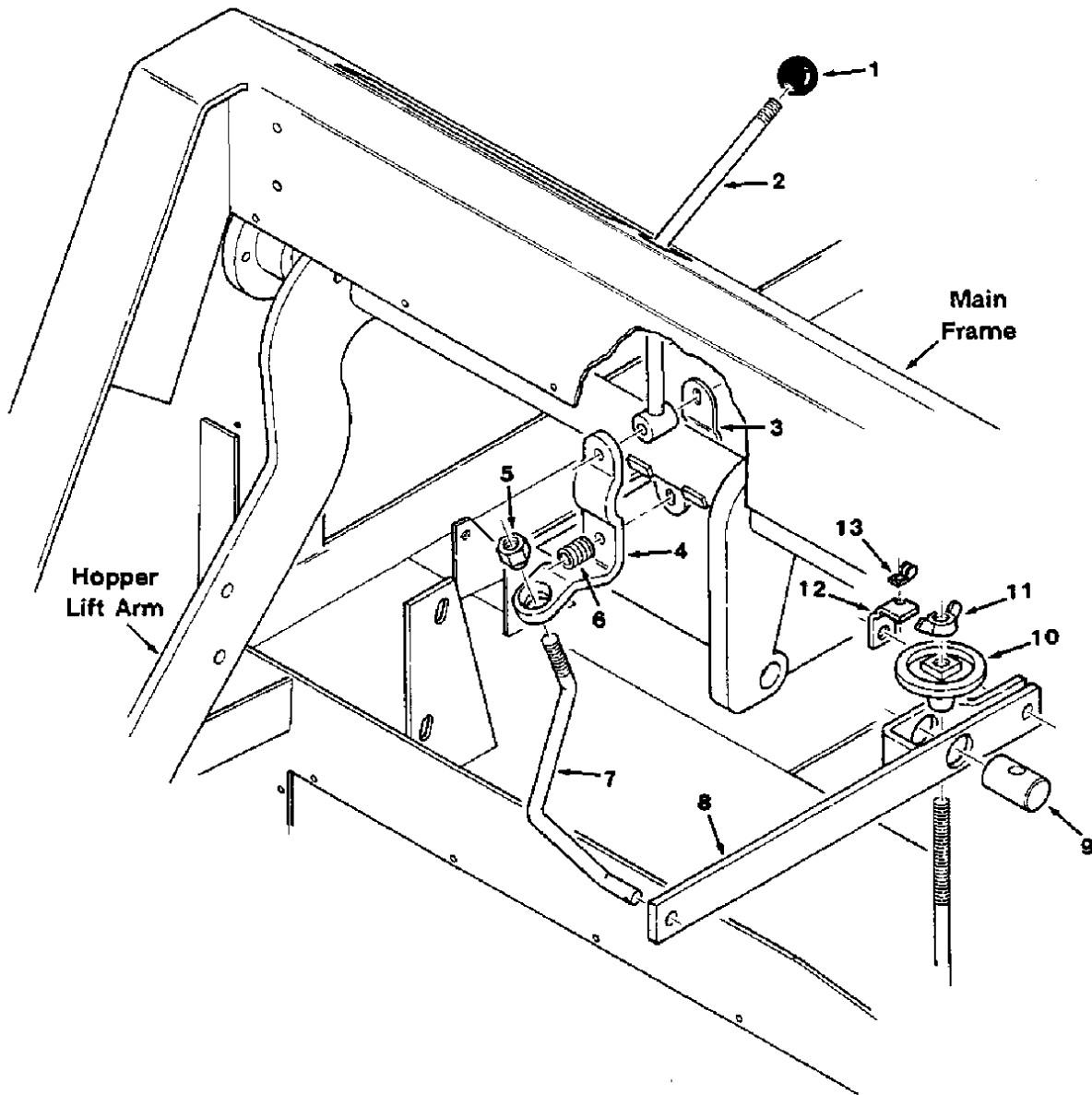

Fig. 14 - Main Brush Lift Group

Fig. 14 - Main Brush Lift Group

02569

Key	Tennant® Part No.	Machine Serial Number	Description	Qty.
1	26156	(000000-)	Knob	1
2	82135	(000000-)	Handle, Brush Lift	1
3	23306-1	(000000-)	Bracket, Clip	1
4	23307-1	(000000-)	Lever, Lift Handle	1
5	24339	(000000-)	Nut, Wheel	1
6	14174	(000000-)	Spring, Compression	1
7	53182	(000000-)	Rod, Lift	1
8	53876	(000000-)	Arm, Lift	1
9	51391	(000000-)	Pin, Swivel	1
10	51452	(000000-)	Knob	1
11	39274	(000000-)	Nut, Wing	1
12	35593	(000000-)	Bracket, Battery Cable	1
13	56094	(000000-)	Clamp, Cable	1

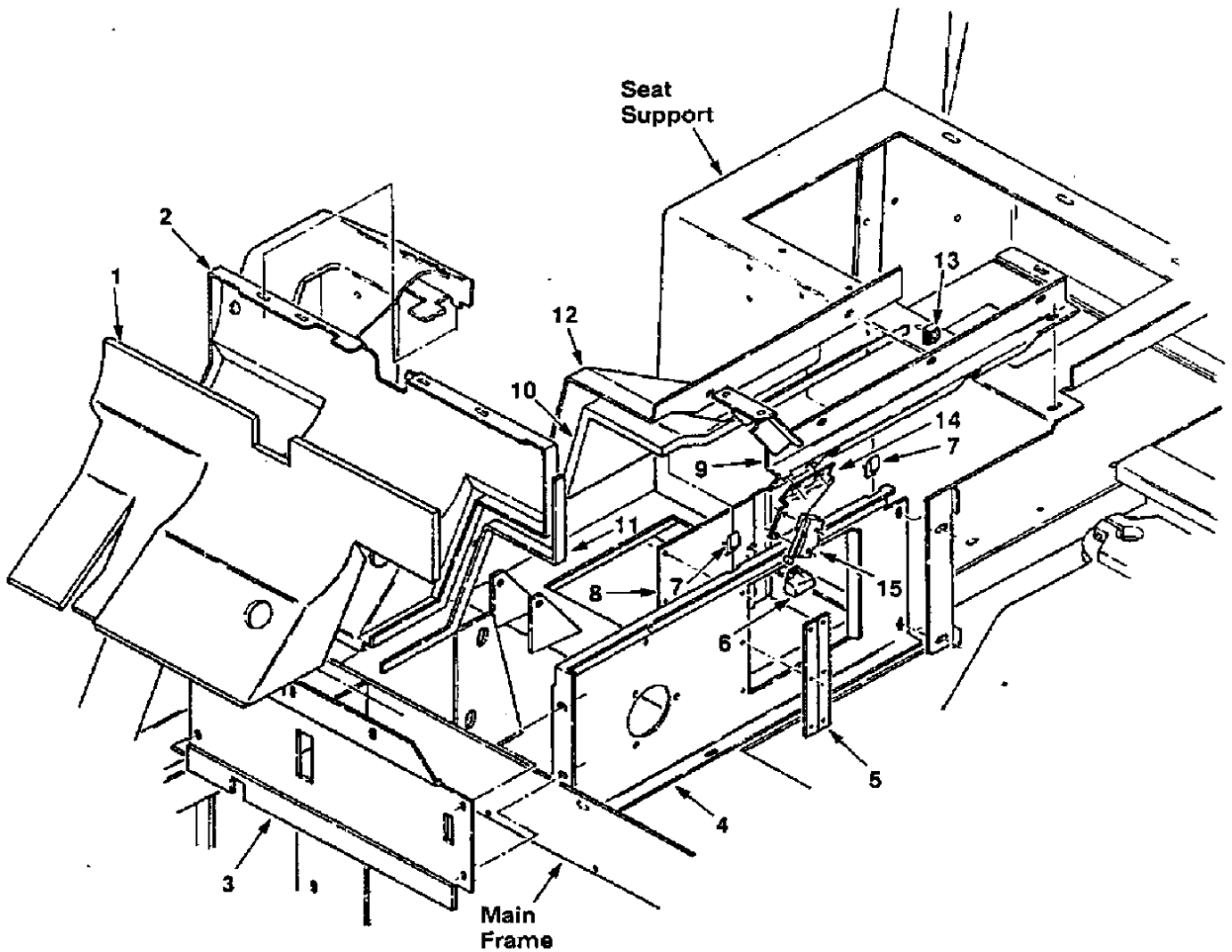

Fig. 15 - Access and Kick Panels Group

02679

Key	Tennant® Part No.	Machine Serial Number	Description	Qty.
1	10870	(000000-)	Insulation, Foam	1
2	10869	(000000-)	Panel, Dashboard	1
3	82363	(000000-)	Panel, Front Kick	1
4	82354	(000000-)	Panel, Kick	1
5	62615	(000000-)	Hinge	1
6	64903	(000000-)	Catch, Roller	1
7	82362	(000000-)	Clip	2
8	82353	(000000-)	Door, Access	1
9	82385	(000000-)	Stiffener, Panel	1
10	82365	(000000-)	Foam, Acoustic	1
11	49351-4	(000000-)	Seal, Foam Rubber	1
12	82360	(000000-)	Panel, Access	1
13	61110	(000000-)	Nut, Retainer	3
14	82084	(002907-)	Bracket, Switch	1
15	82092	(002907-)	Switch, Roller	1

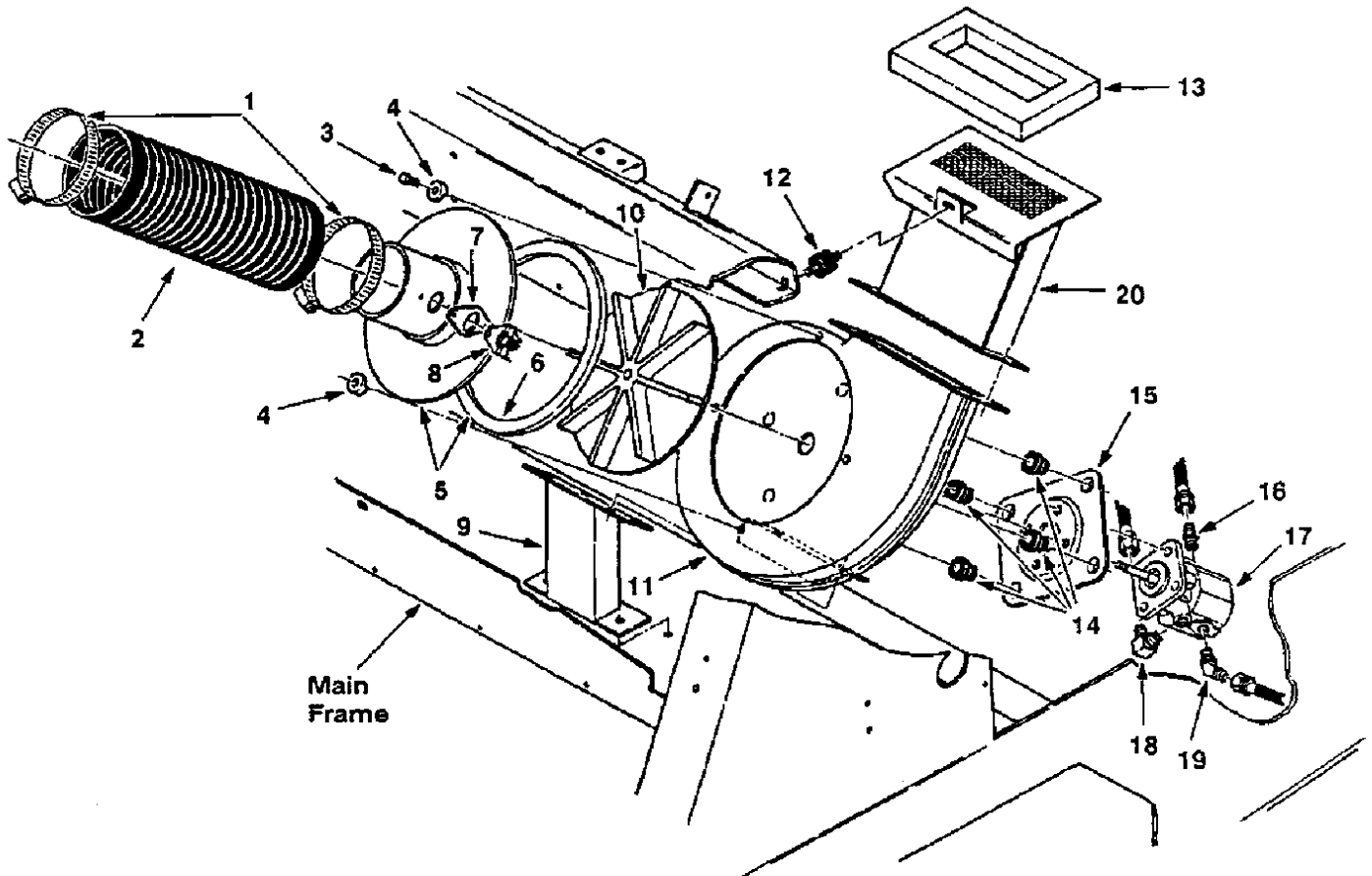

Fig. 16 - Vacuum Fan Group

04499

Key	Tennant® Part No.	Machine Serial Number	Description	Qty.
1	23498	(000000-)	Clamp, Worm Drive	2
2	51881	(000000-)	Hose	1
3	34323	(000000-)	Screw, Hex, Nylon	4
4	03467A	(000000-)	Clip, Vacuum Housing	4
5	82368	(000000-)	Inlet, Vacuum Fan	1
6	23542	(000000-)	Seal, Foam Rubber	1
7	82733	(000000-)	Gasket, Fire Switch	1
8	82782	(000000-)	Thermostat, Sealed	1
9	82391	(000000-003284)	Mount, Fan	1
9	82480	(003285-)	Mount, Fan	1
10	82268	(000000-)	Impeller	1
11	82386	(000000-)	Housing, Impeller	1
12	82661	(000000-)	Isolator, Vibration	1
13	82424	(000000-)	Seal, Muffler	1
14	54274	(000000-)	Isolator, Vibration	4
15	54275A	(000000-)	Bracket, Motor	1
16	44869	(000000-)	Fitting, Straight	1
17	77101	(000000-)	Motor, Hydraulic	1
18	77097	(000000-)	Fitting, Elbow	1
19	42226	(000000-)	Fitting, Elbow, 45°	1
20	82396	(000000-)	Duct, Fan Exhaust	1

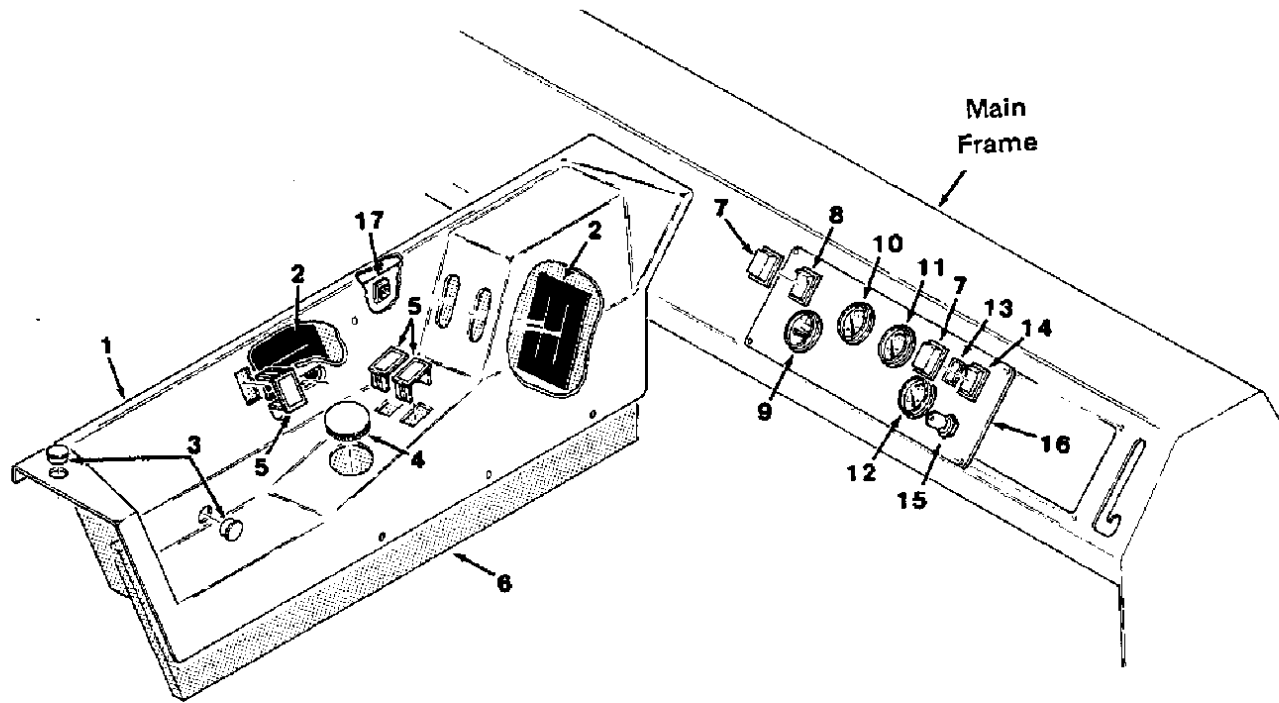

Fig. 17 - Instrument and Control Panels Group

02578

Key	Tennant® Part No.	Machine Serial Number	Description	Qty.
1	82339	(000000-)	Panel, Control	1
2	82299	(000000-)	Seal, Control Panel	2
3	82727	(000000-)	Plugbutton	2
4	82747	(000000-)	Plugbutton	1
5	57772	(000000-)	Plate, Cover	3
6	07642	(000000-)	Foam, Acoustic	1
7	57807	(000000-)	Seal, Switch	2
8	81458	(000000-)	Switch, Rocker	1
9	34810	(000000-)	Meter, Hour	1
10	58591	(000000-)	Gauge, Water Temperature	1
11	03262	(000000-002895)	Replacement Kit, Oil Pressure Gauge	1
11	82626	(002896-)	Gauge, Oil Pressure	1
12	55557	(000000-)	Gauge, Voltage	1
13	79660	(000000-)	Plugbutton, Rectangular	1
14	81459	(000000-)	Switch, Rocker	1
15	55258	(000000-)	Switch, Ignition	1
	62530-1	(000000-)	Key, Switch	1
16	82207	(000000-)	Panel, Instrument	1
17	61110	(000000-)	Nut, Retainer	4

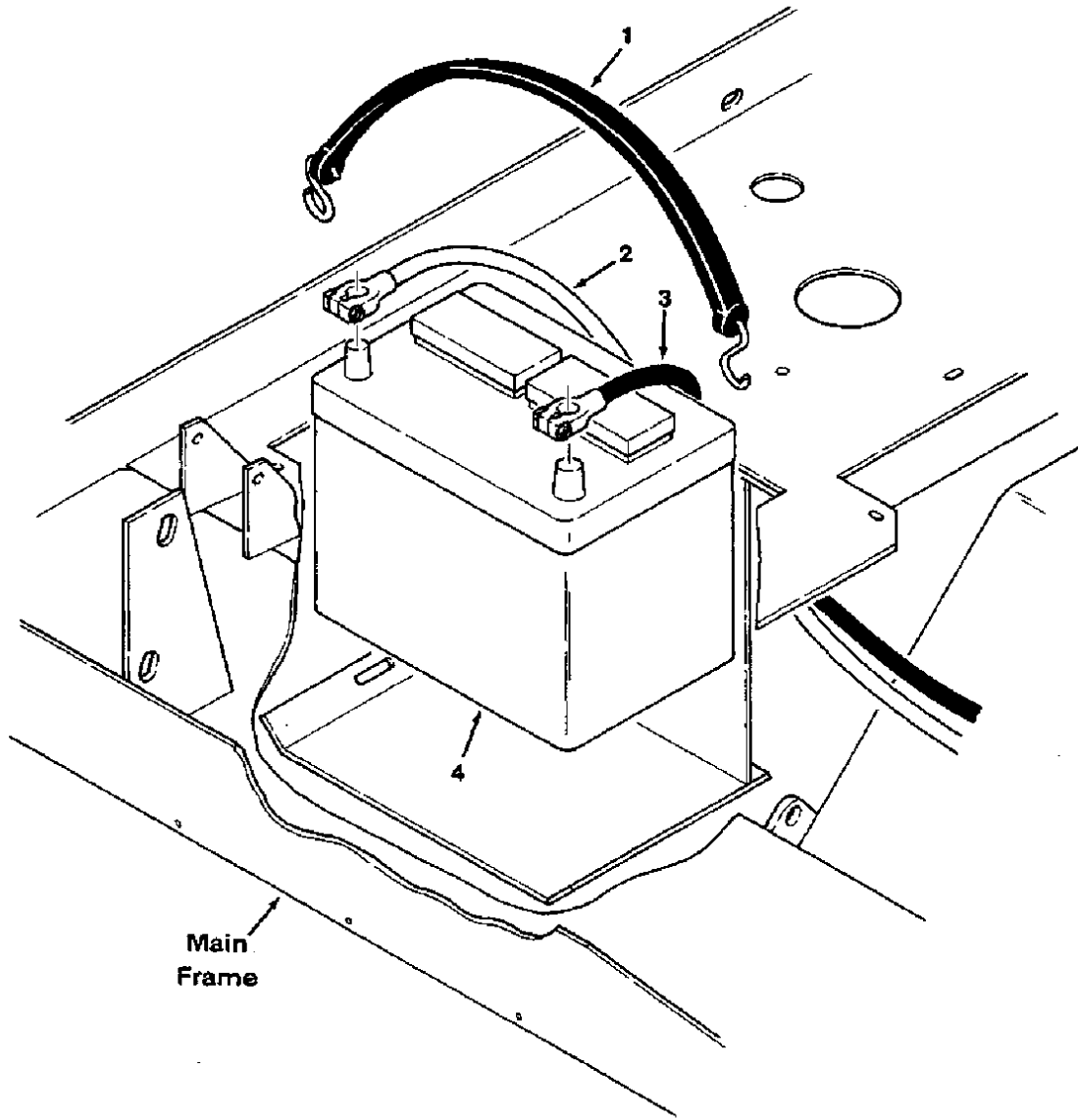
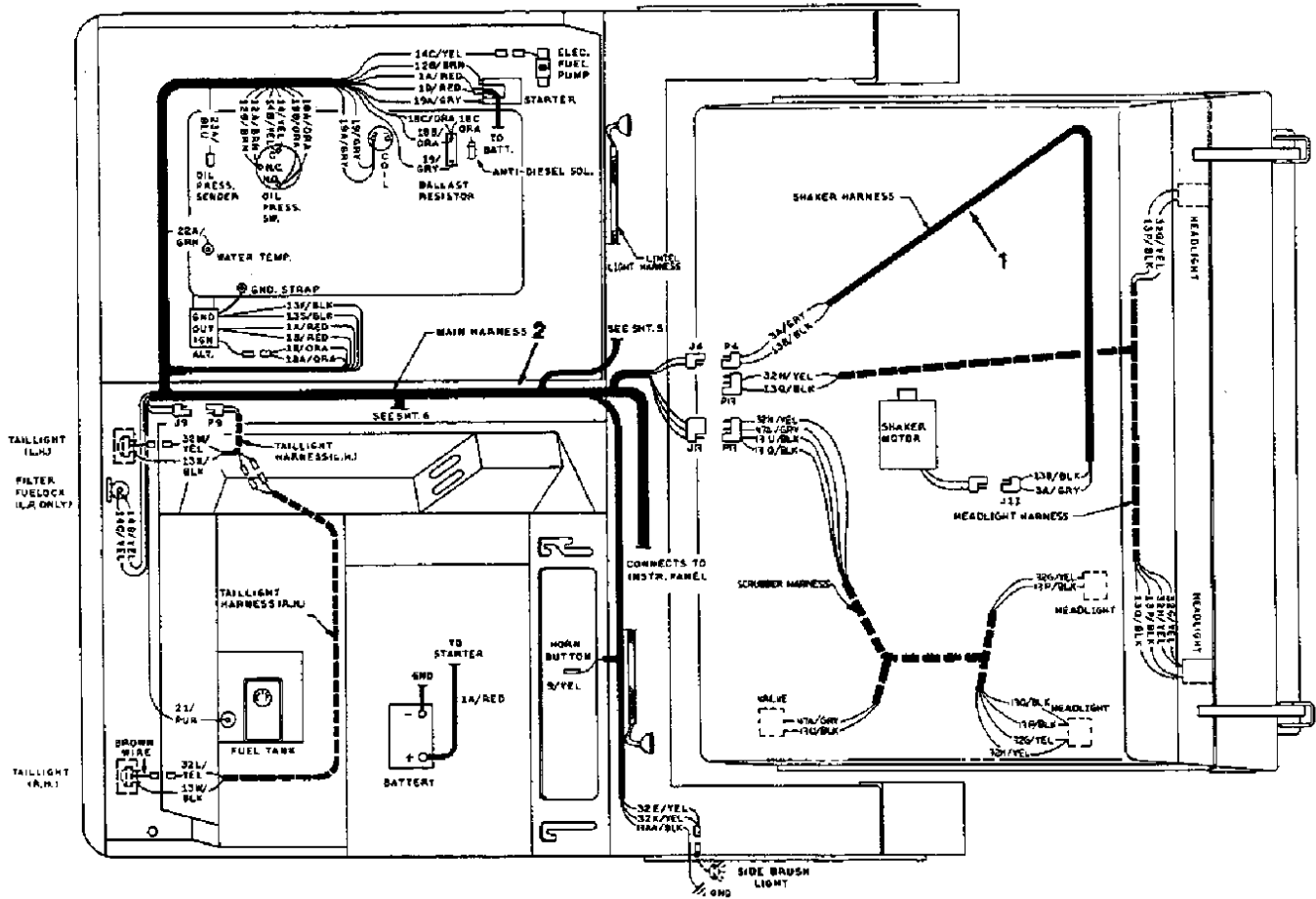

Fig. 18 - Battery Group

02543

Key	Tennant® Part No.	Machine Serial Number	Description	Qty.
1	33671	(000000-)	Strap, Rubber	1
2	82708	(000000-)	Cable, Positive Battery	1
3	82709	(000000-)	Cable, Negative Battery	1
4	10137	(000000-)	Battery, 475 CCA	1



REAR VIEW OF INSTRUMENT PANEL

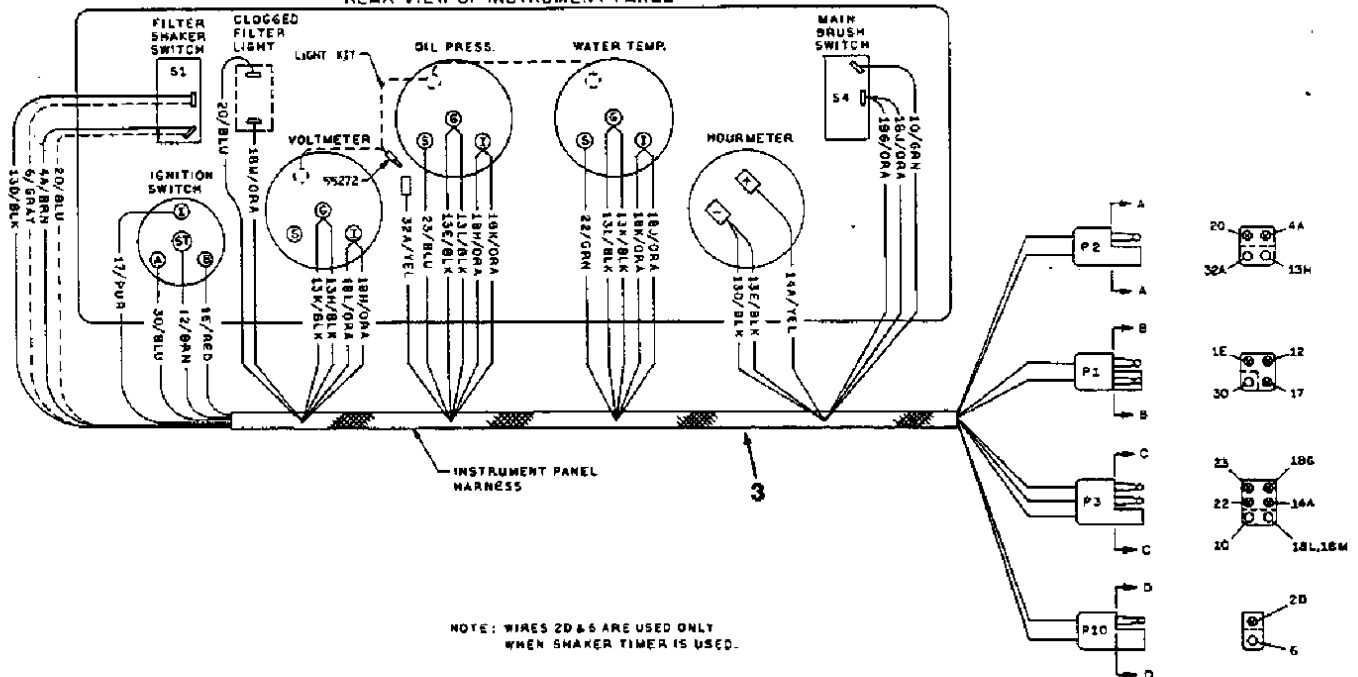

NOTE: WIRES 2D & 6 ARE USED ONLY WHEN SHAKER TIMER IS USED.

Fig. 19 - Wire Harnesses Group

CONTROL PANEL OPTIONS

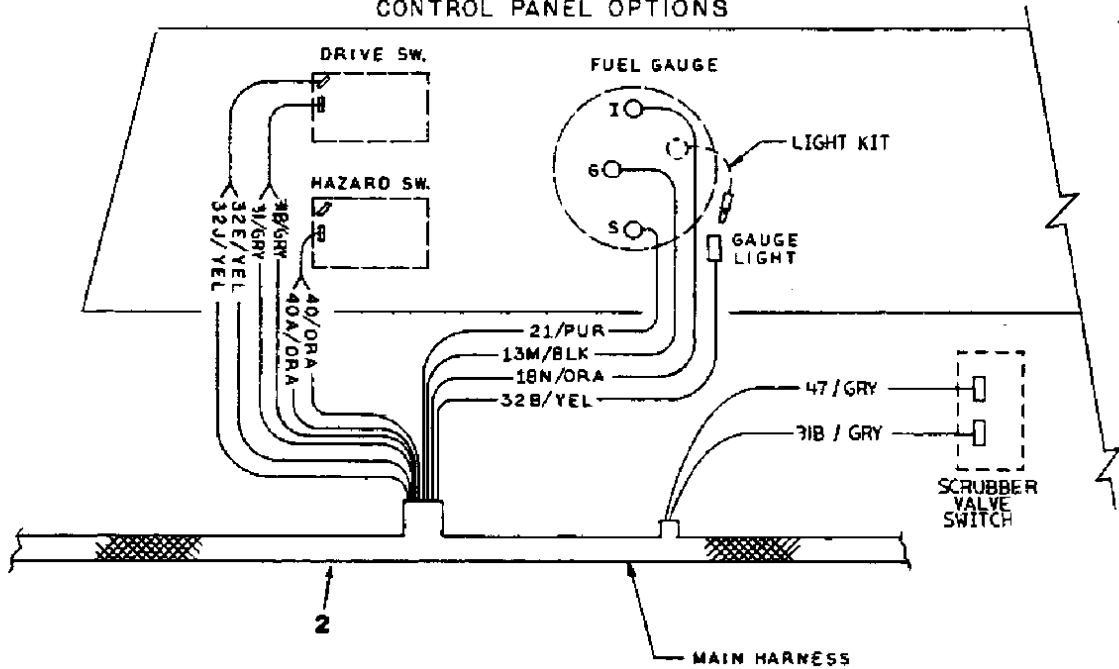

LINTEL ELECTRICAL ASSEMBLY

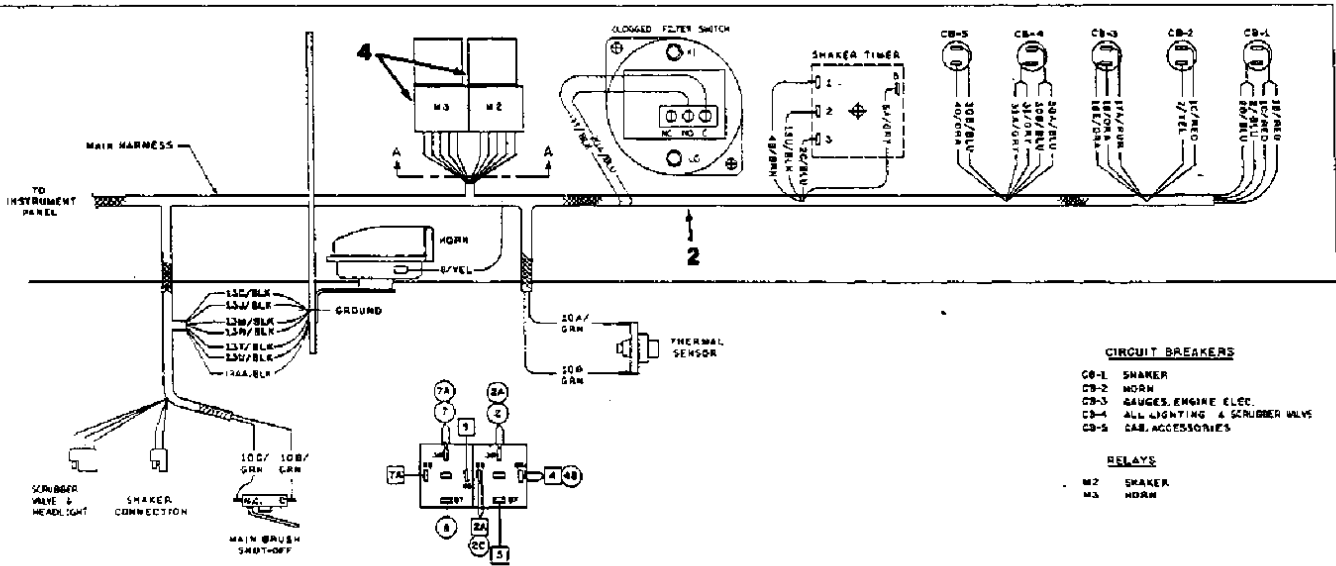

Fig. 19 - Wire Harnesses Group

02548

Key	Tennant® Part No.	Machine Serial Number	Description	Qty.
1	82723	(000000-)	Wire Harness, Shaker	1
2	82702	(000000-)	Wire Harness, Main	1
3	82705	(000000-)	Wire Harness, Instrument Panel	1
4	57804	(000000-)	Relay	2

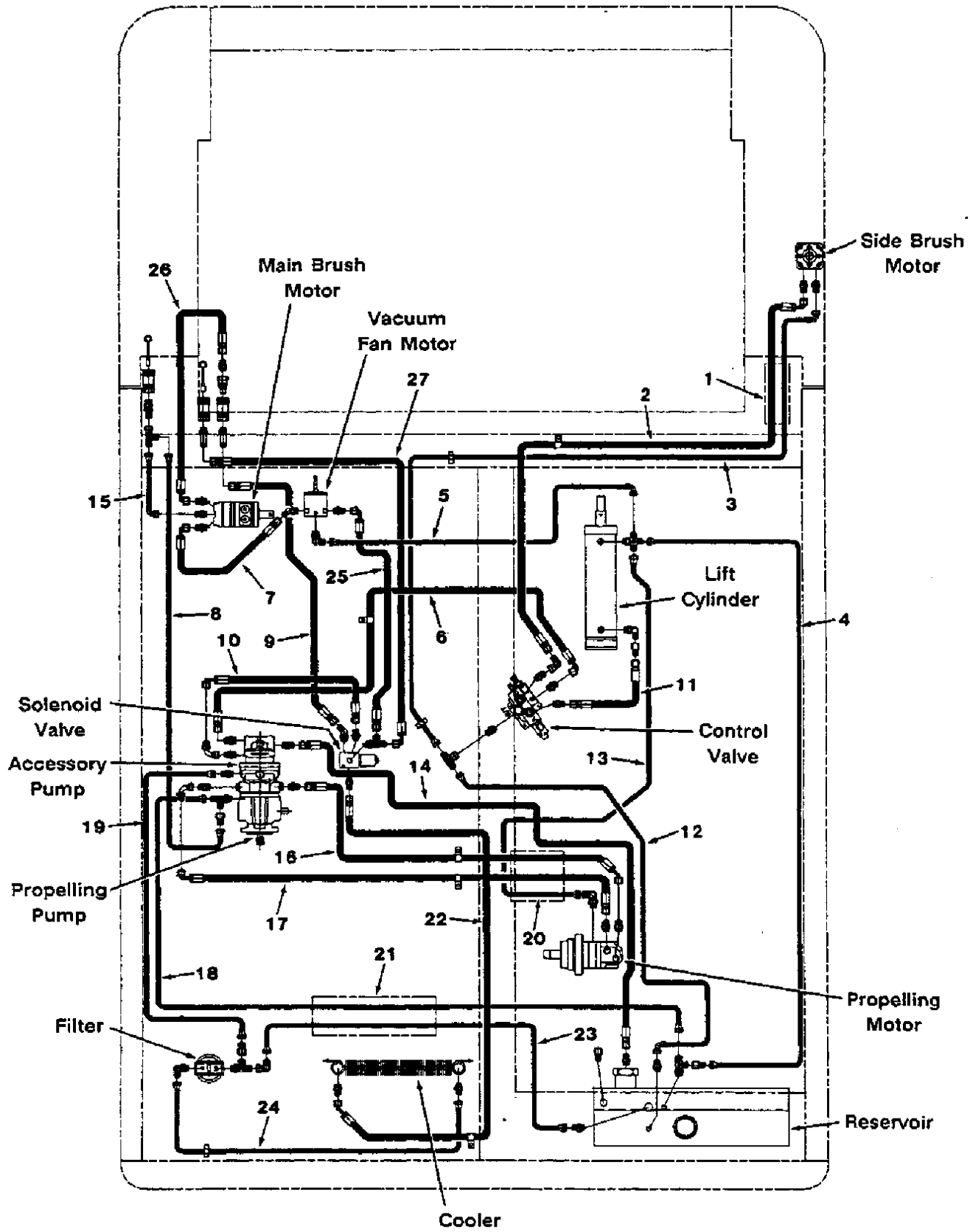

Fig. 20 - Hydraulic Hoses Group

Fig. 20 - Hydraulic Hoses Group

02592

Key	Tennant® Part No.	Machine Serial Number	Description	Qty.
1	82833	(000000-)	Sleeve, Hose	1
2	82819	(000000-)	Hose, Hydraulic	1
3	82810	(000000-)	Hose, Hydraulic	1
4	82803	(000000-)	Hose, Hydraulic	1
5	82805	(000000-)	Hose, Hydraulic	1
6	57582	(000000-)	Hose, Hydraulic	1
7	82820	(000000-)	Hose, Hydraulic	1
8	32550	(000000-)	Hose, Hydraulic	1
9	02999	(000000-)	Hose, Hydraulic	1
10	82822	(000000-)	Hose, Hydraulic	1
11	82814	(000000-)	Hose, Hydraulic	1
12	82809	(000000-)	Hose, Hydraulic	1
13	82804	(000000-002229)	Hose, Hydraulic	1
13	02642	(002230-)	Hose, Hydraulic	1
14	82046	(000000-)	Hose, Hydraulic	1
15	82806	(000000-)	Hose, Hydraulic	1
16	82823	(000000-)	Hose, Hydraulic	1
17	82824	(000000-003284)	Hose, Hydraulic	1
17	82826	(003285-)	Hose, Hydraulic	1
18	82807	(000000-)	Hose, Hydraulic	1
19	82811	(000000-)	Hose, Hydraulic	1
20	82832	(000000-003284)	Sleeve, Hose	1
20	57224	(003285-)	Sleeve, Hose	1
21	82831	(000000-)	Sleeve, Hose	1
22	82821	(000000-)	Hose, Hydraulic	1
23	82835	(000000-)	Hose, Hydraulic	1
24	82649	(000000-)	Hose, Hydraulic	1
25	82840	(000000-)	Hose, Hydraulic	1
26	82818	(000000-)	Hose, Hydraulic	1
27	03001	(000000-)	Hose, Hydraulic	1

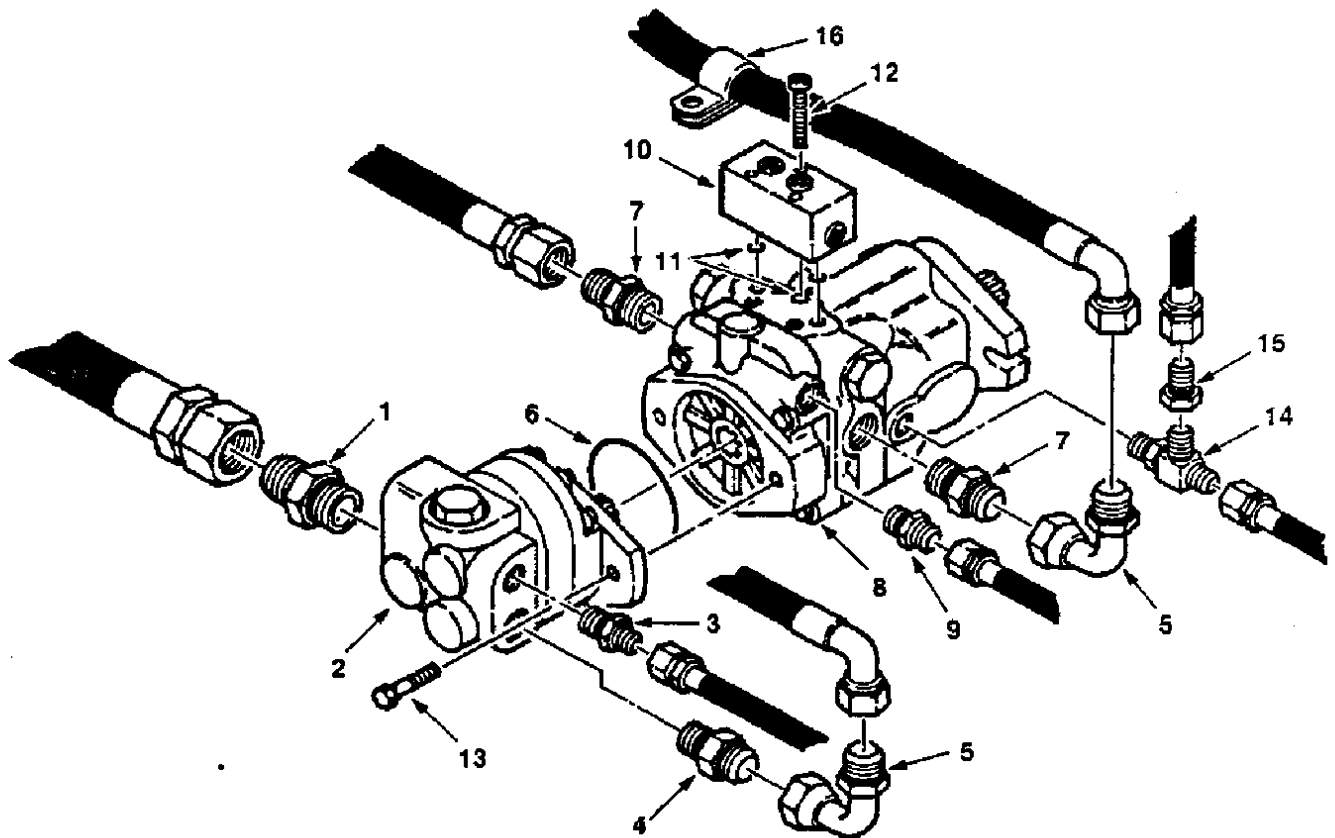

Fig. 21 - Hydraulic Pumps Group

Key	Tennant® Part No.	Machine Serial Number	Description	Qty.
1	52929	(000000-)	Fitting, Straight	1
2	82205	(000000-)	Pump, Hydraulic	1
3	55686	(000000-)	Fitting, Straight	1
4	06750	(000000-)	Fitting, Straight	1
5	57994	(000000-)	Fitting, Elbow	2
6	65145-1	(000000-)	O-Ring	1
7	42260	(000000-)	Fitting, Straight	2
8	02633	(000000-)	Pump, Hydraulic	1
9	44869	(000000-)	Fitting, Straight	1
10	82767	(000000-)	Valve, Hydraulic Neutral	1
11	58395	(000000-)	O-Ring	2
12	82764	(000000-)	Screw, Socket	3
13	82842	(000000-)	Screw, Hex, Nylon	2
14	76316	(000000-)	Fitting, Tee	1
15	47752	(000000-)	Fitting, Straight	1
16	58366	(003285-)	Clamp	1

04501

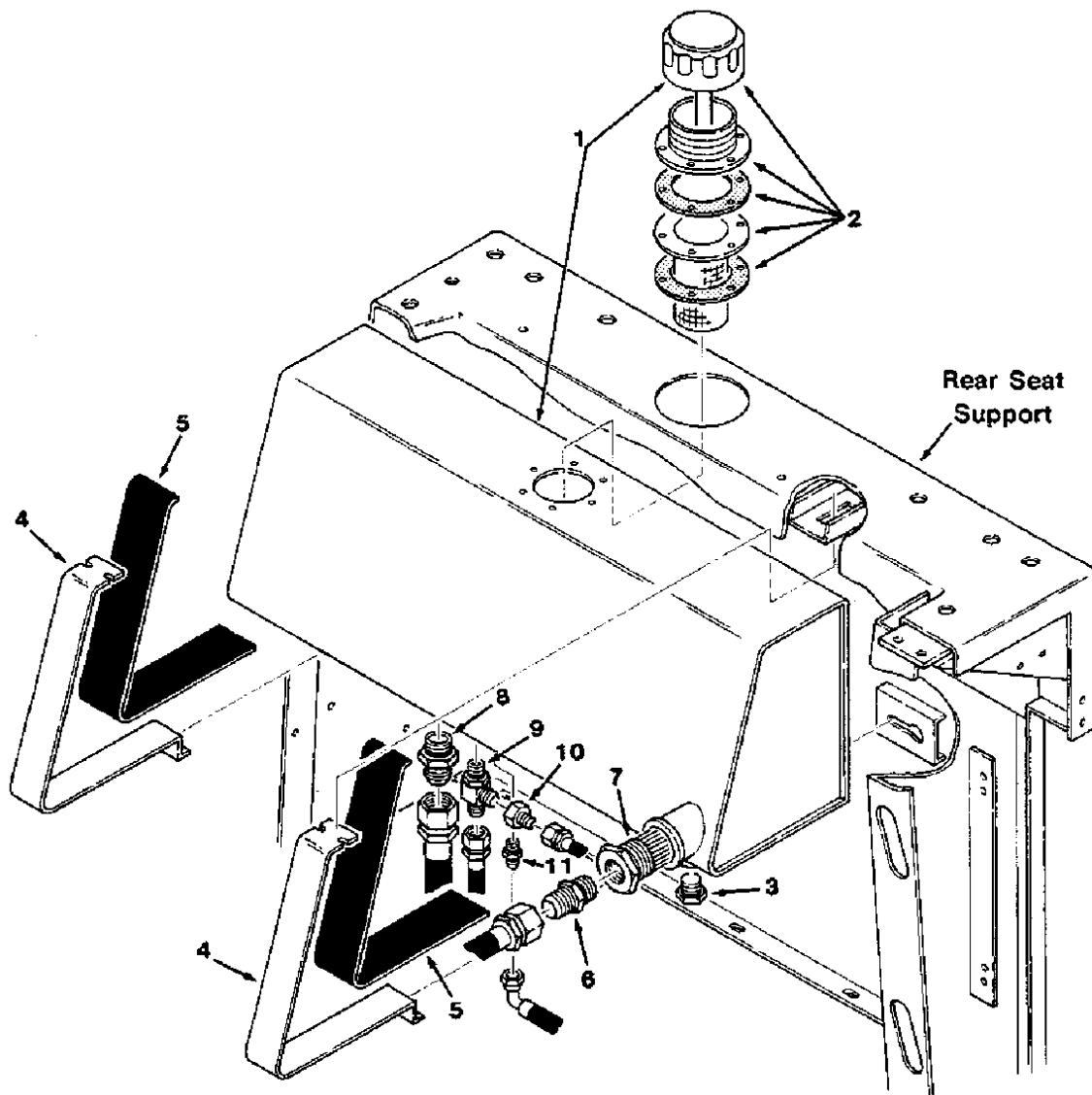

Fig. 22 - Hydraulic Reservoir Group

02571

Key	Tennant® Part No.	Machine Serial Number	Description	Qty.
1	82838	(000000-)	Reservoir Assembly, Hydraulic	1
2	82780	(000000-)	Breather, Filler	1
3	40362	(000000-)	Fitting, Plug	1
4	82779	(000000-)	Strap, Retaining	2
5	82837	(000000-)	Strap, Isolator	2
6	52929	(000000-)	Fitting, Straight	1
7	82784	(000000-)	Strainer, Suction	1
8	82796	(000000-)	Valve, Check	1
9	76316	(000000-)	Fitting, Tee	1
10	47752	(000000-)	Fitting, Straight	1
11	56690	(000000-)	Fitting, Straight	1

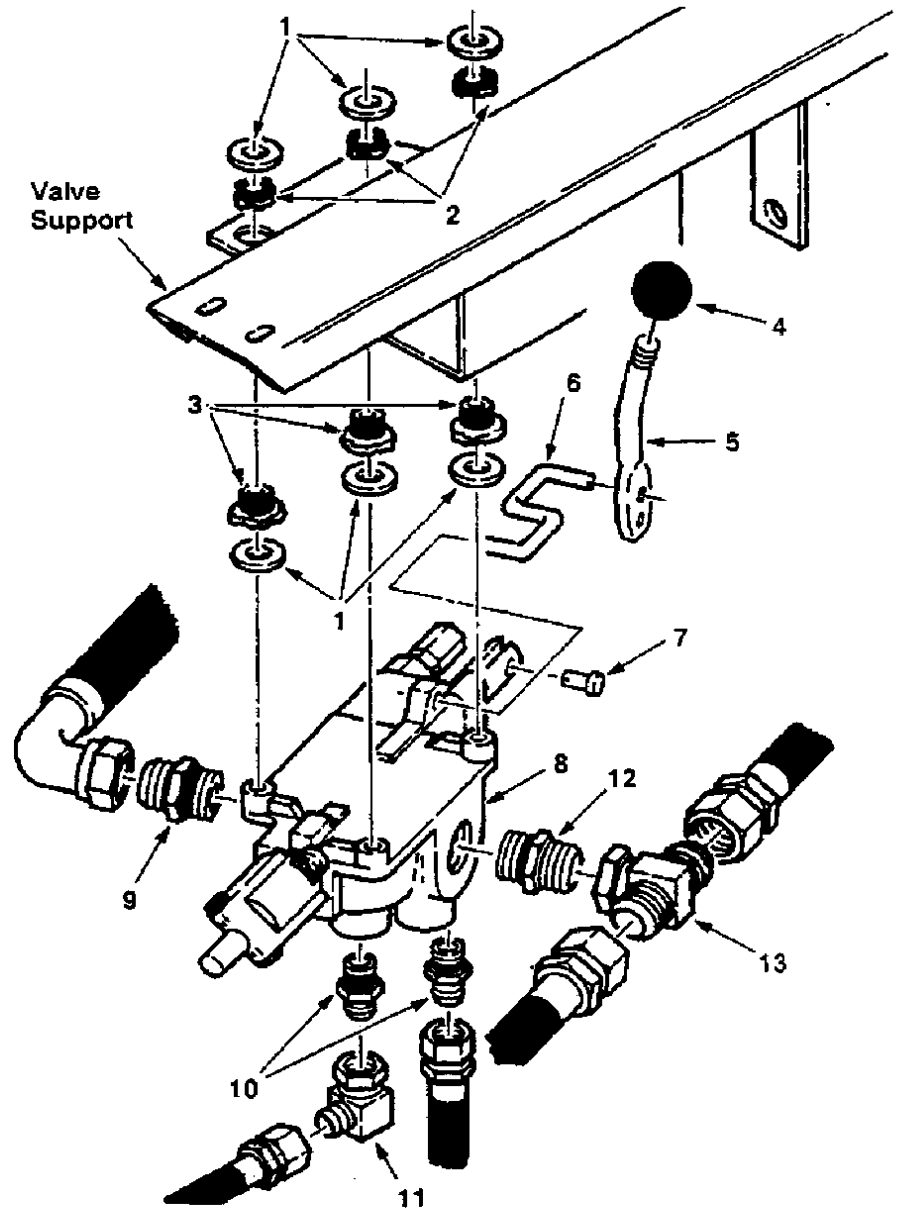
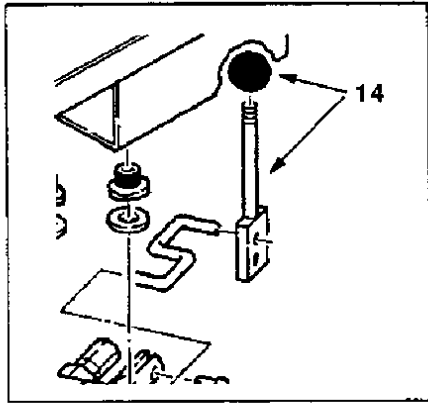

Fig. 23 - Hydraulic Control Valve Group

04500

Key	Tennant® Part No.	Machine Serial Number	Description	Qty.
1	30013	(000000-)	Washer	6
2	62172	(000000-)	Ring	3
3	62173	(000000-)	Bushing	3
4	26156	(003438-)	Knob	1
5	02687	(003438-)	Handle, Valve	1
6	82762	(000000-)	Link, Hook	1
7	14605	(000000-)	Pin, Clevis	1
8	62550	(000000-)	Valve, Hydraulic	1
9	57984	(000000-)	Fitting, Straight	1
10	55686	(000000-)	Fitting, Straight	2
11	39210	(000000-)	Fitting, Elbow	1
12	47508	(000000-)	Fitting, Straight	1
13	35586	(000000-)	Fitting, Tee	1
14	02688	(000000-003437)	Replacement Kit, Handle	1

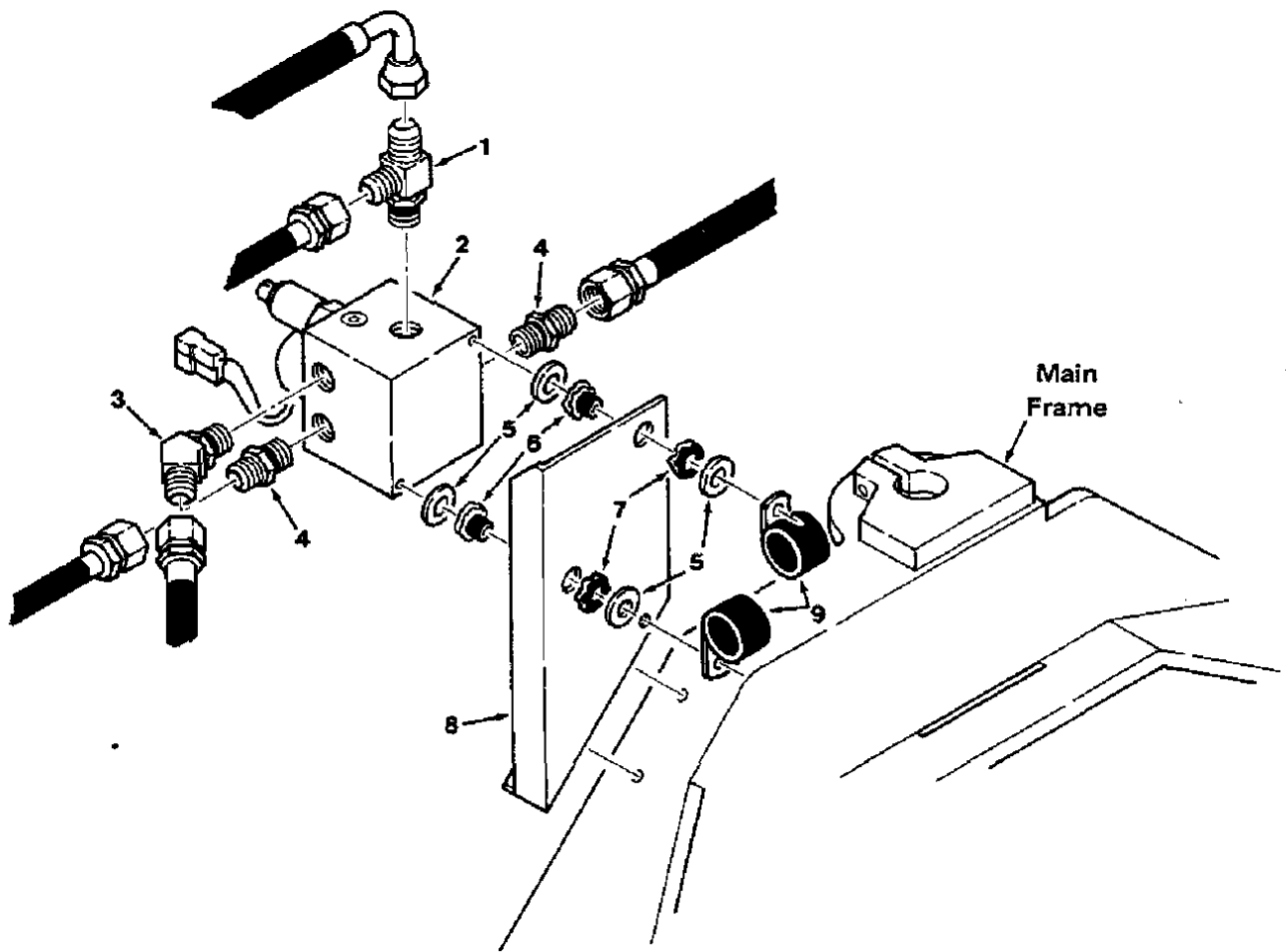

Fig. 24 - Hydraulic Solenoid Valve Group

02565

Key	Tennant® Part No.	Machine Serial Number	Description	Qty.
1	40755	(000000-)	Fitting, Tee	1
2	82754	(000000-)	Valve, Hydraulic Solenoid	1
3	42226	(000000-)	Fitting, Elbow, 45°	1
4	62390	(000000-)	Fitting, Straight	2
5	30013	(000000-)	Washer	4
6	62173	(000000-)	Bushing	2
7	62172	(000000-)	Ring	2
8	82795	(000000-)	Bracket, Valve	1
9	58366	(000000-)	Clamp, Support	2

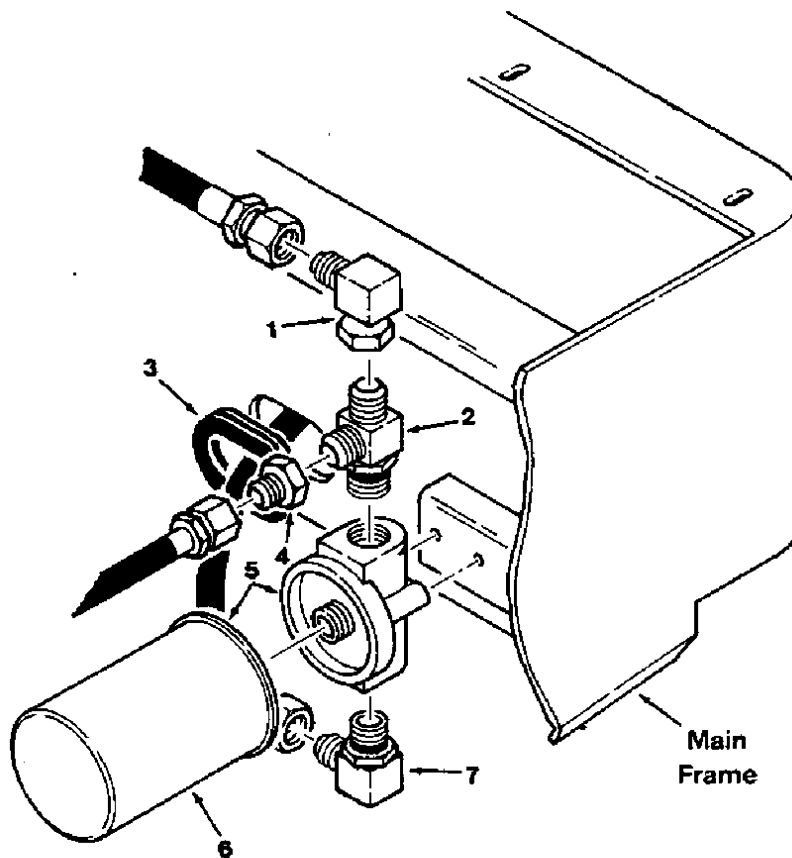

Fig. 25 - Hydraulic Filter Group

02535

Key	Tennant® Part No.	Machine Serial Number	Description	Qty.
1	35033	(000000-)	Fitting, Elbow	1
2	42216	(000000-)	Fitting, Tee	1
3	10632-19	(000000-)	Grommet	1
4	78143	(000000-)	Fitting, Straight	1
5	55619	(000000-)	Filter Assembly, Hydraulic	1
6	55740	(000000-)	Element, Hydraulic Filter	1
7	46481	(000000-)	Fitting, Elbow	1

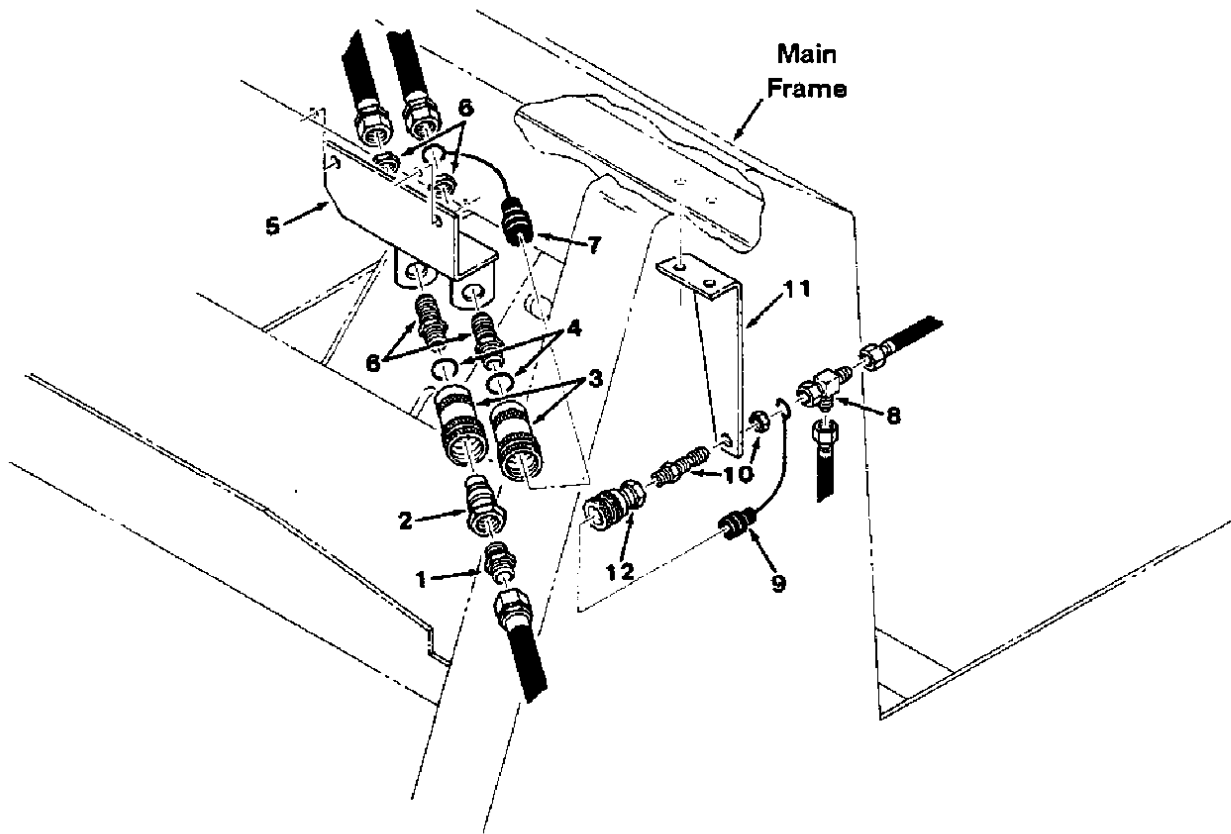

Fig. 26 - Hydraulic Couplings Group

02784

Key	Tennant® Part No.	Machine Serial Number	Description	Qty.
1	44869	(000000-)	Fitting, Straight	1
2	65084-1	(000000-)	Fitting, Coupling, Male	1
3	65084-2	(000000-)	Fitting, Coupling, Female	2
4	77006	(000000-)	O-Ring	2
5	03004	(000000-)	Bracket, Quick-Disconnect	1
6	82918	(000000-)	Fitting, Bulkhead	2
7	82620	(000000-)	Plug, Dust	1
8	57988	(000000-)	Fitting, Tee	1
9	33797	(000000-)	Plug, Dust	1
10	82621	(000000-)	Fitting, Bulkhead	1
11	03006	(000000-)	Bracket, Support	1
12	34414	(000000-)	Fitting, Coupling, Female	1

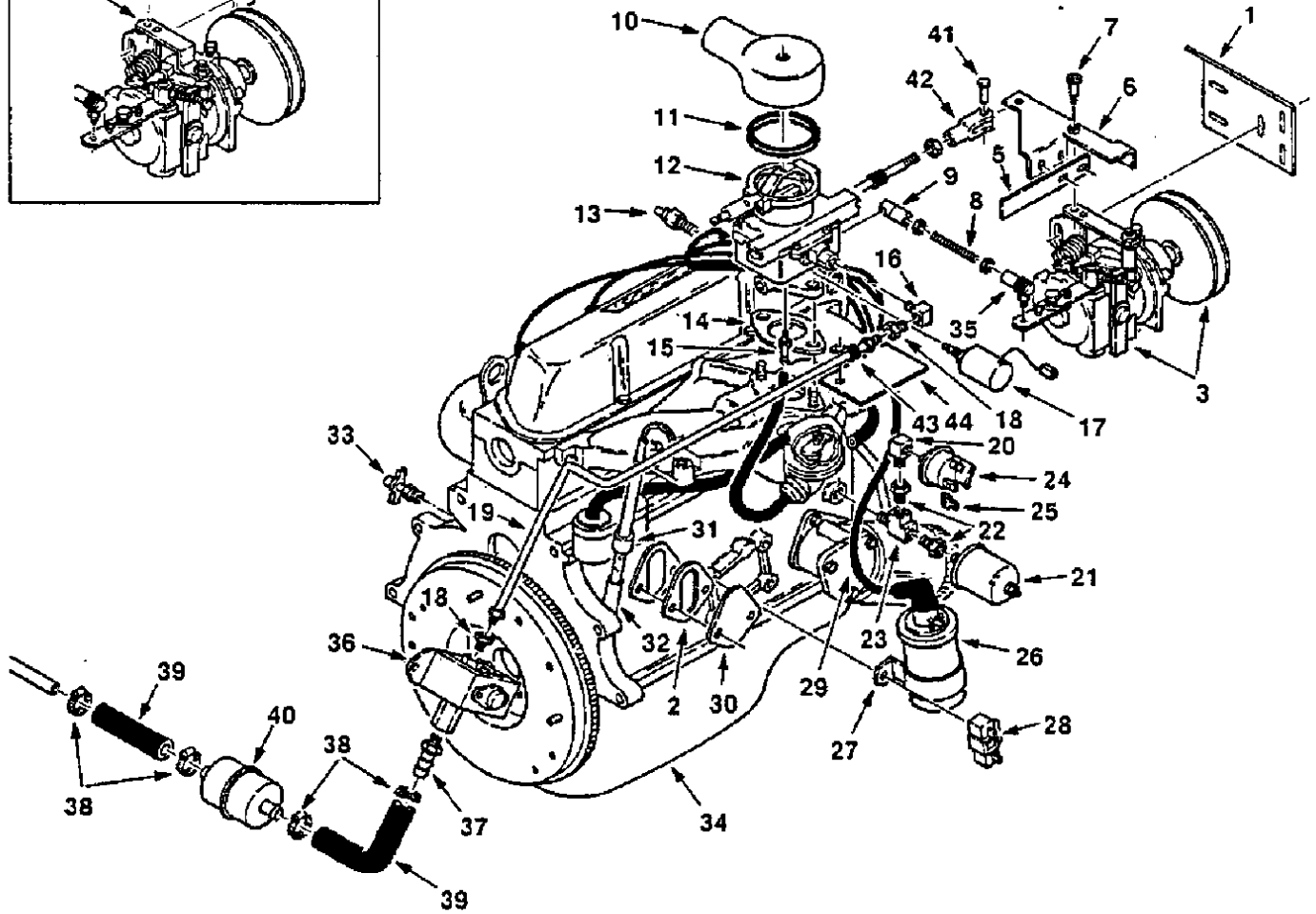
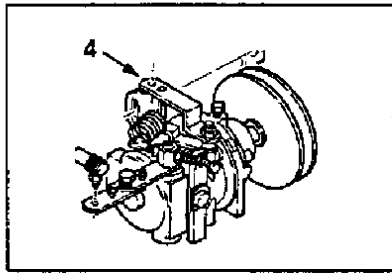



Fig. 27 - Engine Group

Fig. 27 - Engine Group

02681

Key	Tennant® Part No.	Machine Serial Number	Description	Qty.
1	13515	(000000-)	Plate, Mounting	1
2	02887	(000000-)	Gasket	1
3	82660	(000000-)	Governor, Mechanical	1
4	82264	(xxxxxx-)	Service Kit, Governor Lever	1
5	82678	(000000-)	Spring, Flat	1
6	82655	(000000-)	Arm, Governor	1
7	40823	(000000-)	Screw, Shoulder	1
8	34898	(000000-)	Stud, Throttle	1
9	50332-1	(000000-)	Ball Joint	1
10	34997	(000000-)	Elbow, Carburetor	1
11	16738	(000000-)	Gasket, Carburetor	1
12	12044	(000000-)	Carburetor	1
13	58592	(000000-)	Sender, Temperature	1
14	54912-8	(000000-)	Gasket, Carburetor	1
15	40607	(000000-)	Fitting, Straight, Barbed	1
16	11984	(000000-)	Fitting, Elbow	1
17	68616	(000000-)	Valve, Anti-Dieseling	1
18	40585	(000000-)	Fitting, Straight	2
19	82586	(000000-)	Fuel Line	1
20	11984	(000000-)	Fitting, Elbow	1
21	34808	(000000-002895)	Sender, Oil Pressure	1
21	82627	(002896-)	Sender, Oil Pressure	1
22	17414	(000000-)	Fitting, Straight	2
23	24929	(000000-)	Fitting, Tee	1
24	51805	(000000-)	Switch, Oil Pressure	1
25	68106	(000000-)	Terminal, Tab	3
26	54911-11	(000000-)	Coil	1
27	54911-30	(000000-)	Strap, Coil	1
28	54911-15	(000000-)	Resistor	1
29	54911-31	(000000-)	Wire	1
30	54911-28	(000000-)	Cover	1
31	82535	(000000-)	Dipstick	1
32	82584	(000000-)	Tube, Dipstick	1
33	54911-32	(000000-)	Draincock, Block	1
34	58087	(000000-)	Engine	1
35	14601	(000000-)	Ball Joint	1
36	54230	(000000-)	Pump, Fuel	1
37	82544	(000000-)	Fitting, Straight, Barbed	1
38	43844	(000000-)	Clamp, Worm Drive	4
39	82526	(000000-)	Hose, Fuel Line	2
40	82525	(000000-)	Filter, Fuel	1
41	14605	(000000-)	Pin, Clevis	1
42	14595-1	(000000-)	Clevis, Adjustable	1
43	46236	(000000-)	Clamp, Cable	1
44	82534	(000000-)	Shield, Drip	1

Home Find... Go To..  

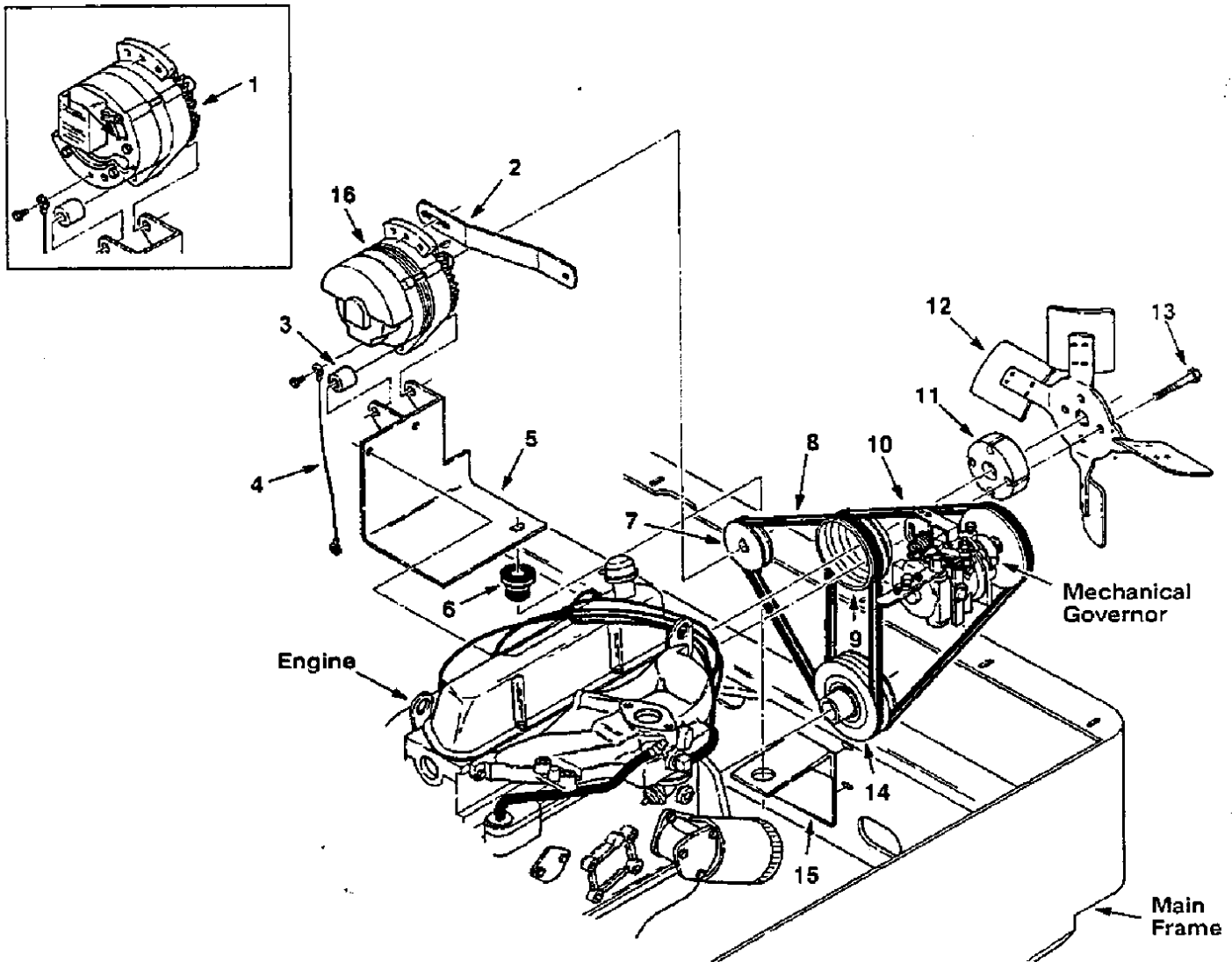

Fig. 28 - Sheaves and Belts Group

02683

Key	Tennant® Part No.	Machine Serial Number	Description	Qty.
1	08894	(000000-003357)	Replacement Kit, Alternator	1
2	50309	(000000-)	Strip, Bracket	1
3	54959	(000000-)	Spacer	1
4	82731	(000000-)	Wire, Alternator Ground	1
5	82523	(000000-)	Bracket, Mounting	1
6	51176	(000000-)	Dampener, Engine	1
7	54914	(000000-)	Sheave	1
8	44561	(000000-)	V-Belt	1
9	82675	(000000-)	Pulley, Water Pump	1
10	82687	(000000-)	V-Belt	1
11	82542	(000000-)	Spacer, Fan	1
12	16805	(000000-)	Fan	1
13	39278	(000000-)	Screw, Hex, M8	4
14	82536	(000000-)	Pulley, Crankshaft	1
15	82583	(000000-)	Bracket, Mount	1
16	03233	(003358-)	Alternator	1
	06889	(003358-)	Jumper Wire	1

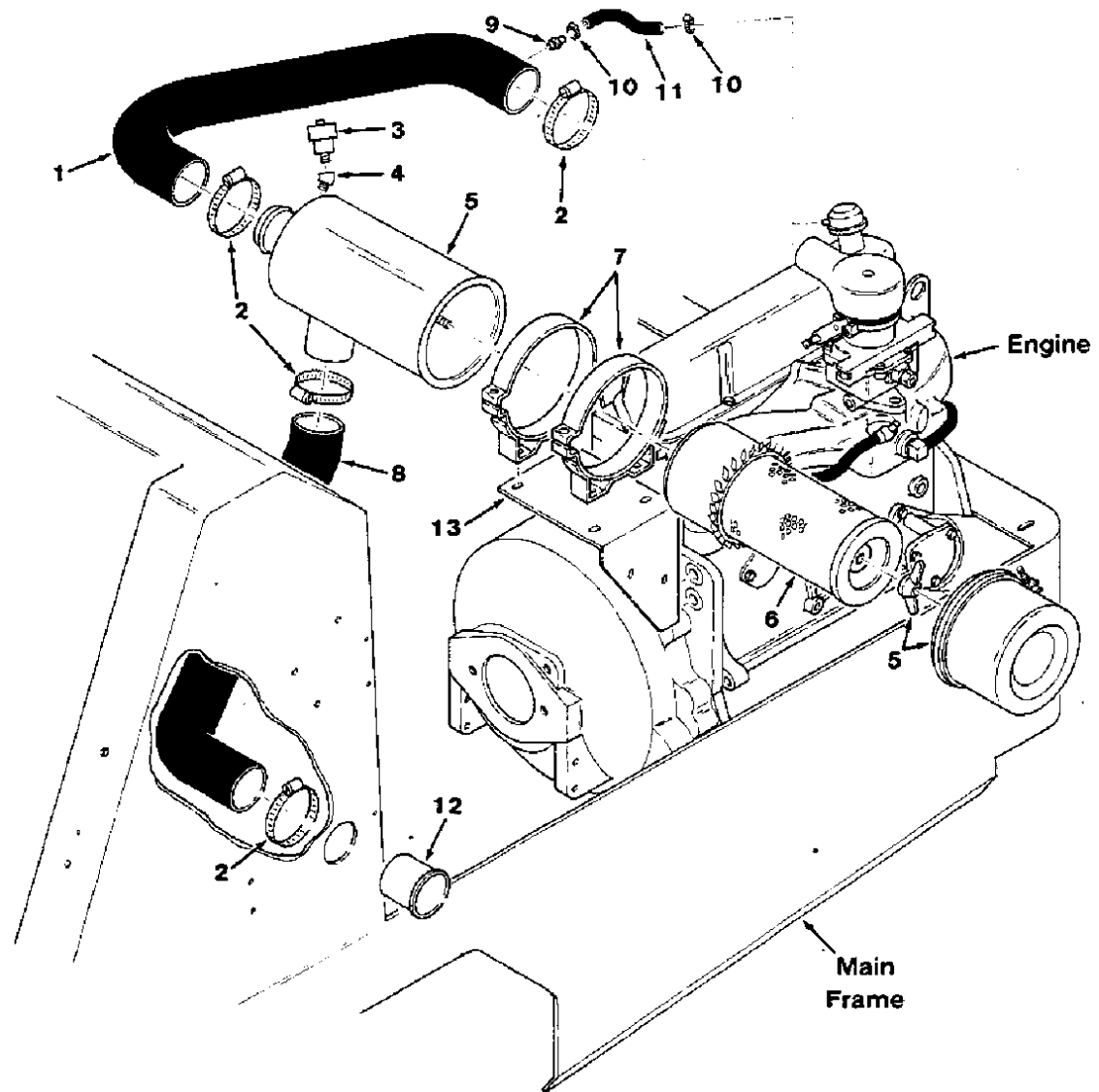

Fig. 29 - Air Cleaner Group

02579

Key	Tennant® Part No.	Machine Serial Number	Description	Qty.
1	82552	(000000-)	Hose, Air Intake	1
2	14432	(000000-)	Clamp, Worm Drive	4
3	82685	(000000-)	Indicator, Filter Service	1
4	24976	(000000-)	Fitting, Elbow 45°	1
5	58538	(000000-)	Air Cleaner	1
6	58120	(000000-)	Filter, Air	1
7	51560-3	(000000-)	Clamp, Mounting	2
8	82676	(000000-)	Hose, Air Intake	1
9	82533	(000000-)	Spud	1
10	54333	(000000-)	Clamp, Worm Drive	2
11	32666	(000000-)	Hose, Rubber	1
12	58346	(000000-)	Tube, Air Intake	1
13	82555	(000000-)	Bracket, Air Cleaner	1

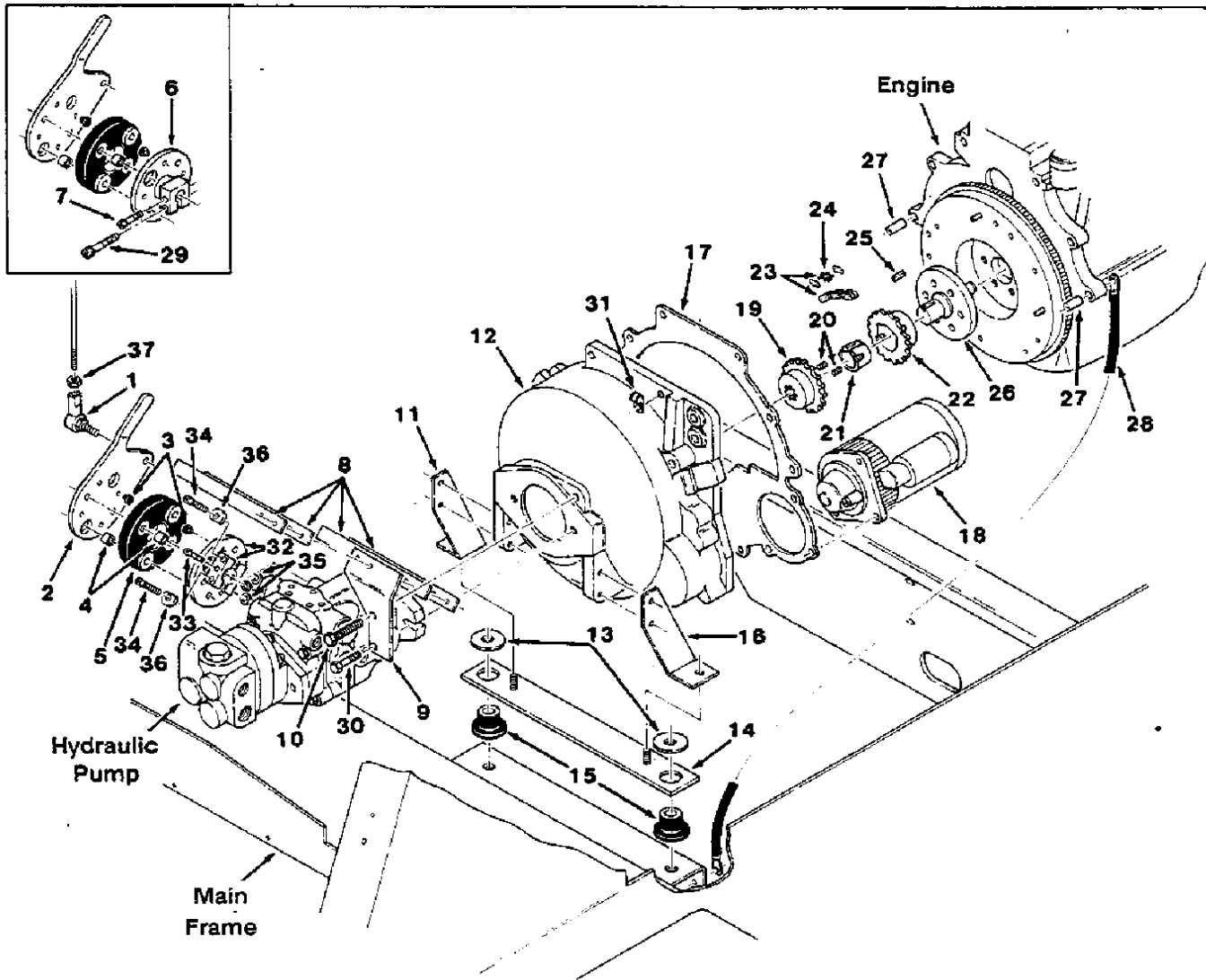

Fig. 30 - Flywheel Housing and Coupling Group

Fig. 30 - Flywheel Housing and Coupling Group

02545

Key	Tennant® Part No.	Machine Serial Number	Description	Qty.
1	50493	(000000-002926)	Ball Joint	1
1	82260	(002927-)	Ball Joint	1
2	82215	(003014-)	Plate, Pump Control	1
3	56855	(000000-)	Bumper, Rubber	8
4	64991	(000000-)	Sleeve	4
5	57875	(000000-)	Coupling, Shaft	1
6	82249	(000000-003013)	Replacement Kit, L.H. Coupling	1
7	31249	(000000-003013)	Screw, Shoulder	1
8	49681	(000000-)	Plate, Spring	4
9	82786	(000000-)	Bracket, Spring	1
10	55347	(000000-)	Screw, Hex	1
11	82519	(000000-)	Angle, Support, R.H.	1
12	33826	(000000-)	Housing, Flywheel	1
13	32492	(000000-)	Washer	2
14	82517	(000000-)	Support, Bell Housing	1
15	51176	(000000-)	Dampener, Engine	2
16	82520	(000000-)	Angle, Support, L.H.	1
17	54911-5	(000000-)	Ring, Locating	1
18	57549	(000000-)	Starter	1
19	53386	(000000-)	Coupling, Spline	1
20	15280-1	(000000-)	Bushing	1
21	39330	(000000-)	Screw, Set	2
22	53531-2	(000000-)	Coupling, Chain	1
23	33778	(000000-)	Chain	1
24	33692	(000000-)	Link, Chain	1
25	00926	(000000-)	Key, Square	1
26	47933	(000000-)	Adaptor, Pump	1
27	54911-16	(000000-)	Pin, Dowel	2
28	57773	(000000-)	Wire, Ground	1
29	31248	(000000-003013)	Screw, Socket	1
30	82842	(000000-)	Screw, Hex, Nylon	2
31	76736	(000000-)	Clamp, Cable	1
32	04081	(003014-)	Coupling Assembly, L.H.	1
33	31249	(003014-)	Screw, Shoulder	1
34	19580	(003014-)	Screw, Socket	2
35	03556	(003014-)	Nut, Self-locking	2
36	09787	(003014-)	Washer, Clipped	2
37	82889	(002927-)	Nut, Jam	1

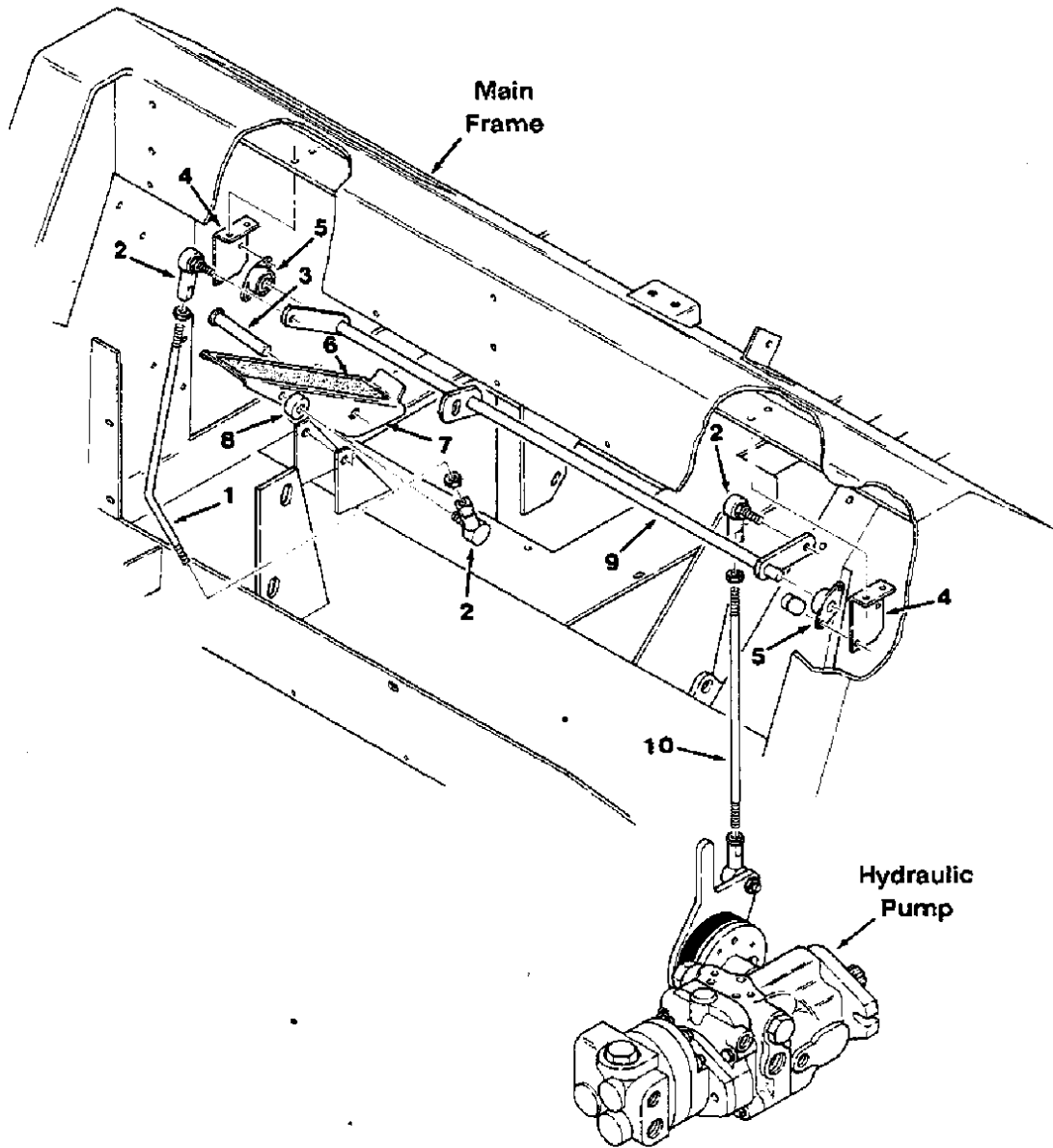

Fig. 31 - Directional Control Group

02568

Key	Tennant® Part No.	Machine Serial Number	Description	Qty.
1	82748	(000000-)	Rod, Accelerator Control	1
2	50493	(000000-)	Ball Joint	3
3	23683	(000000-)	Pin, Clevis	1
4	53351A	(000000-)	Support, Control Rod	2
5	53352	(000000-)	Bearing, Flange	2
6	82839	(000000-)	Pad, Tread	1
7	82836	(000000-)	Pedal	1
8	69462	(000000-)	Sleeve	1
9	82793	(000000-)	Rod, Drive Linkage	1
10	82209	(000000-002926)	Replacement Kit, Stud	1
10	82258	(002927-)	Stud	1

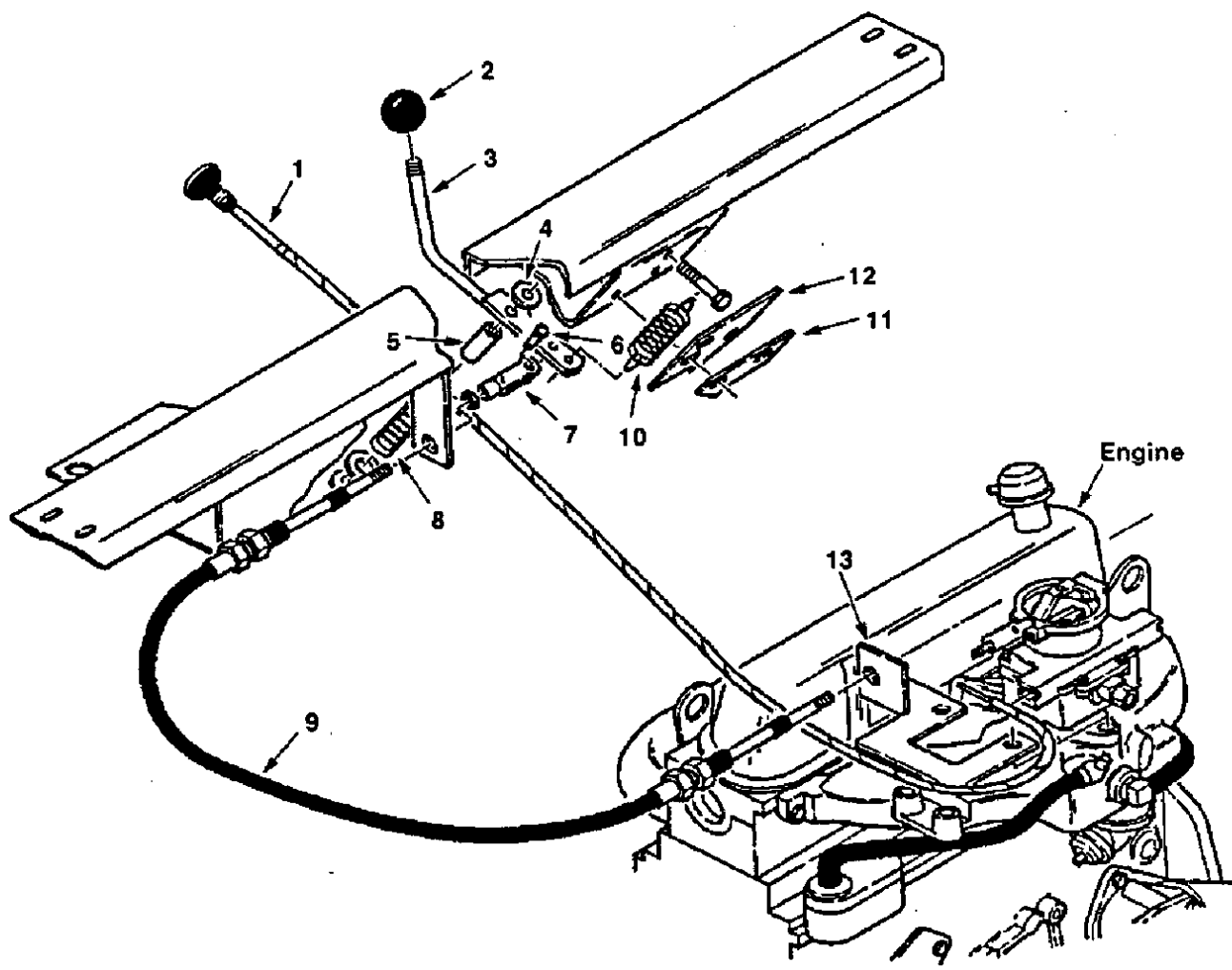

Fig. 32 - Throttle Linkage Group

02577

Key	Tennant® Part No.	Machine Serial Number	Description	Qty.
1	69266	(000000-)	Cable, Choke	1
2	26585	(000000-)	Knob	1
3	07358	(000000-)	Handle	1
4	43611	(000000-)	Washer, Nylon	1
5	68000	(000000-)	Spacer	1
6	14605	(000000-)	Pin, Clevis	1
7	14595-1	(000000-)	Clevis, Adjustable	1
8	39457	(000000-)	Spring, Compression	1
9	67815	(000000-)	Cable	1
10	01053	(000000-)	Spring, Tension	1
11	82677	(000000-)	Plate, Stop	1
12	82669	(000000-)	Plate, Stop	1
13	82672	(000000-)	Bracket, Cable	1

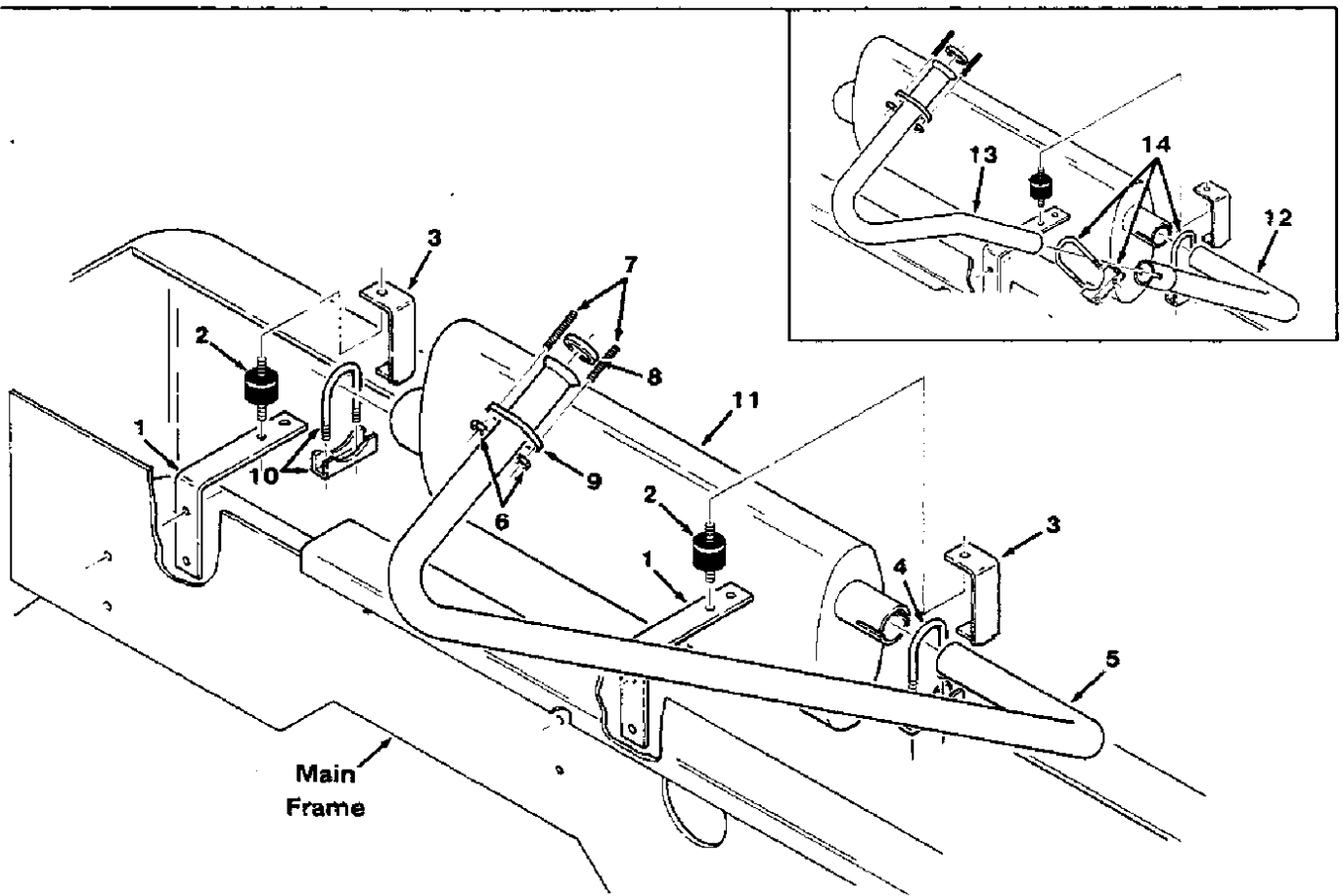

Fig. 33 - Muffler Group

03350

Key	Tennant® Part No.	Machine Serial Number	Description	Qty.
1	82546	(000000-)	Bracket, Hanger	2
2	82661	(000000-)	Isolator, Vibration	2
3	82545	(000000-)	Hanger, Muffler	2
4	24012	(002328-)	Clamp, Muffler	1
5	03047	(002328-)	Tube, Exhaust	1
6	39312	(000000-)	Nut, M10	2
7	32841	(000000-)	Stud	2
8	32840	(000000-)	Gasket, Exhaust	1
9	32839	(000000-)	Flange, Exhaust	1
10	23693	(000000-)	Clamp, Muffler	1
11	82581	(000000-)	Muffler	1
12	82548	(000000-002327)	Tube, Exhaust	1
13	82540	(000000-002327)	Tube, Exhaust	1
14	24012	(000000-002327)	Clamp, Muffler	2

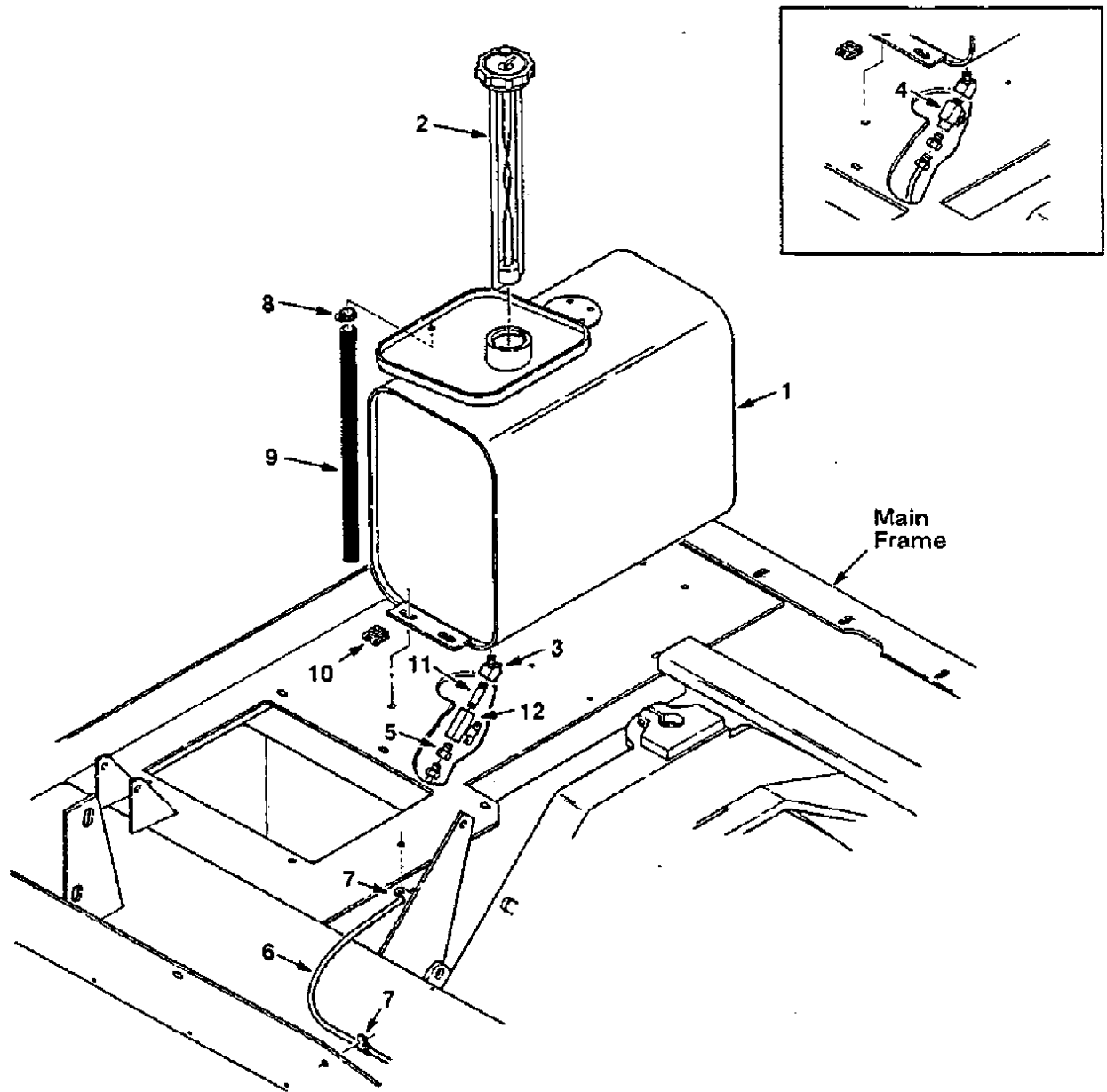

Fig. 34 - Fuel Tank Group

02539

Key	Tennant® Part No.	Machine Serial Number	Description	Qty.
1	82728	(000000-)	Tank, Fuel	1
2	82730	(000000-)	Cap, Tank	1
3	24976	(000000-)	Fitting, Elbow, 45°	1
4	08876	(000000-001911)	Replacement Kit, Cock	1
5	40585	(000000-)	Fitting, Straight	1
6	82524	(000000-)	Tube Assembly	1
7	46236	(000000-)	Clamp, Cable	3
8	54333	(000000-)	Clamp, Worm Drive	1
9	34258	(000000-)	Hose	1
10	02485	(000000-)	Nut, Retainer	4
11	48144	(001912-)	Fitting, Nipple	1
12	08873	(001912-)	Valve, Ball	1

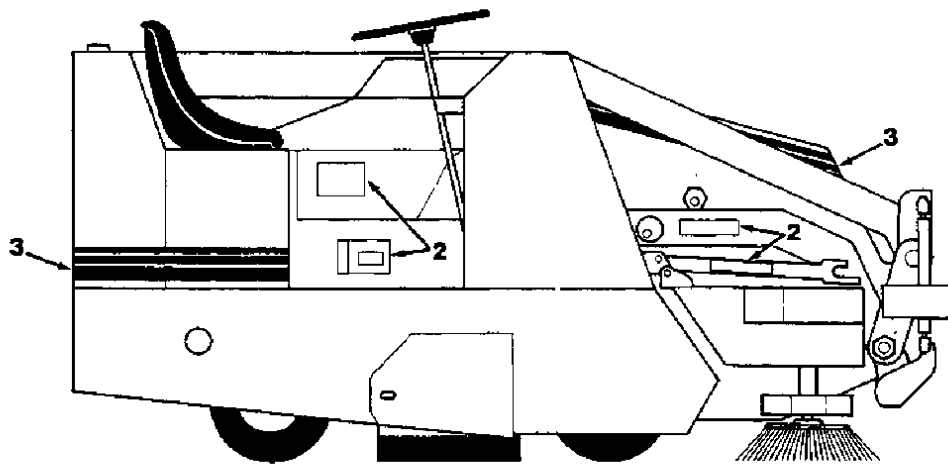
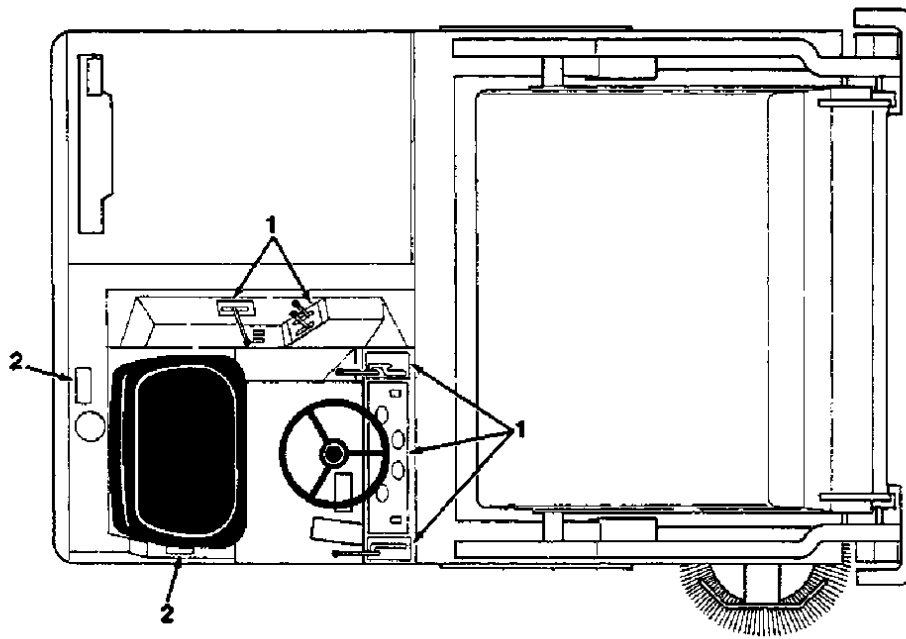

Fig. 35 - Labels Group

02622

Key	Tennant® Part No.	Machine Serial Number	Description	Qty.
1	82713	(000000-)	Label Kit, Operational	1
2	82740	(000000-)	Label Kit, Information and Hazard	1
3	82741	(000000-)	Label Kit, Striping	1

SECTION 6 LPG PARTS

CONTENTS

	Page
Ordering Repair Parts	6-1
Fig. 1 - Fuel Tank and Bumper Group	6-2
Fig. 2 - Carburetor Group, LPG	6-4

NOTE: Section 6, LPG Parts, lists repair parts unique to an LPG powered machine.

Home

Find...

Go To..



ORDERING REPAIR PARTS

The components used in this machine have been carefully selected for performance and safety. Use only Tennant Company specified or equivalent parts.

To receive prompt service in filling of your parts orders, please direct all orders for parts with Tennant Company part numbers to the Tennant Company, and all orders for parts with vendor part numbers to the local supplier of the respective vendor.

When ordering parts, please furnish all of the following information:

1. Machine model number - shown on the machine data plate.

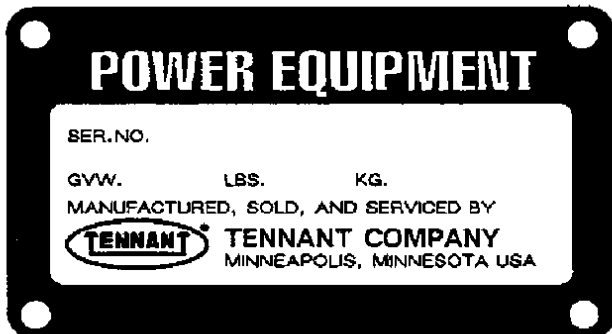

2. Machine serial number - shown on the machine data plate.
3. Power source - gasoline, LPG, diesel, electric.
4. Company name.
5. Shipping address.
6. Billing address.
7. Name, first and last - of person ordering parts.
8. Telephone number.
9. Purchase order number.
10. Part number, description, and quantity - of each item on the order.

Do not order parts by key number or the figure number of the illustrated parts. Indented items indicate parts of assemblies. Standard hardware is furnished only when part of a purchased assembly. Please get hardware from a local hardware supplier.

If the old part cannot be identified, send it to us with the quantity needed specified on the order.

Any claim for loss or damage to a shipment in transit should be filed promptly against the transportation company making the delivery. Shipments will be complete unless the packing list or order acknowledgement indicate items back ordered.

If parts received are suspected to be incorrect or defective, please write, wire, or phone the Tennant Company representative from whom you ordered the part. They will give authorization for return and/or handle replacement shipments when required.

SERIAL NUMBER INFORMATION EXPLANATION

Serial number listings are shown to indicate on which machines each part can be used. These listings are explained by the following examples:

(000000-) The part can be used on all machines.

(003342-) The part can be used on all machines beginning with the serial number listed.

(000000-004320) The part can be used on all machines up to and including serial number listed.

(004321-005678) The part can be used on all machines between and including the serial numbers listed.

Where xxxxxx's are listed in place of a serial number, it indicates a change was made but the exact serial number had not been established when the catalog went to press.

SI UNITS OF MEASURE (INTERNATIONAL SYSTEM)

Metric equivalents have been included, where applicable, throughout this parts catalog.

FASTENER STRENGTH IDENTIFICATION

Fasteners required to have high-strength qualities equivalent to SAE Grade 8 are identified throughout this catalog by the description GR 8. Unless identified by this description, all standard fasteners are SAE Grade 5.

(Specifications and design subject to change without notice.)

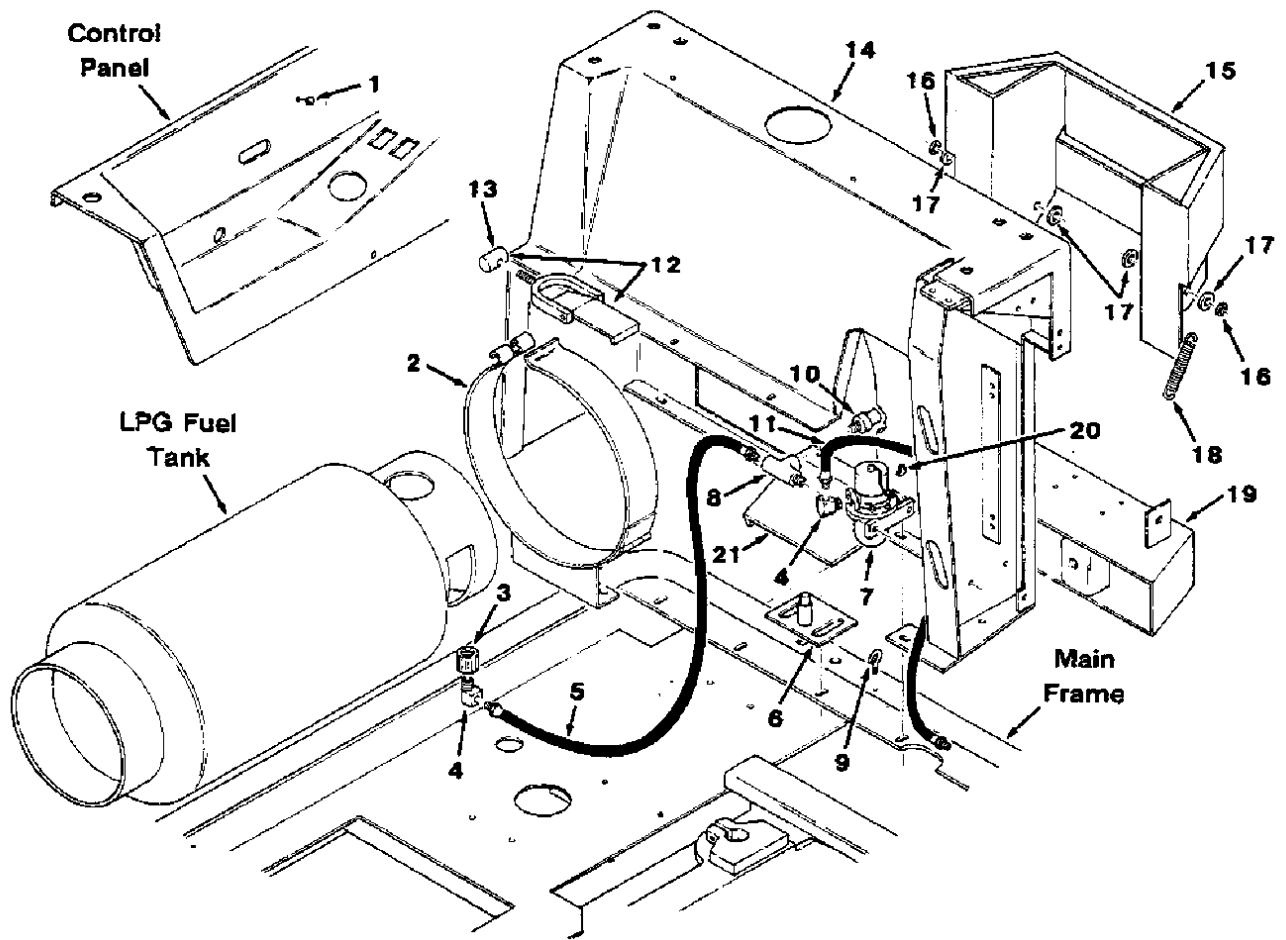

Fig. 1 - Fuel Tank and Bumper Group, LPG

NOTE: To identify parts shown but not listed here, see Section 5, Low Dump Model Parts.

Fig. 1 - Fuel Tank and Bumper Group, LPG

02704

Key	Tennant® Part No.	Machine Serial Number	Description	Qty.
1	47178-11	(000000-)	Plugbutton	1
2	55653	(000000-)	Bracket, Mounting	1
3	26496	(000000-)	Coupling, LPG	1
4	27048	(000000-)	Fitting, Elbow	2
5	22308-3	(000000-)	Hose, LPG	1
6	55556	(000000-)	Bracket, Locator Stud	1
7	33555	(000000-)	Fuel Filter Lock	1
	SK1444	(000000-)	Repair Kit, Fuel Filter	1
8	56976A	(000000-)	Fitting, Tee	1
9	11893	(000000-)	Bolt, Eye	1
10	24047	(000000-)	Valve, Pressure Relief	1
11	47192	(000000-)	Hose, LPG	1
12	53400-1	(000000-)	Latch	1
13	53400-4	(000000-)	Lug	1
14	82340	(000000-)	Support, Seat, LPG	1
15	55633	(000000-)	Bumper, LPG	1
16	46231	(000000-)	Sleeve	2
17	20536-1	(000000-)	Washer, Nylon	4
18	29499	(000000-)	Spring, Tension	1
19	82180	(000000-)	Bumper, LPG	1
20	68106	(000000-)	Terminal, Tab	1
21	02696	(002299-)	Shield, Fuel Line	1

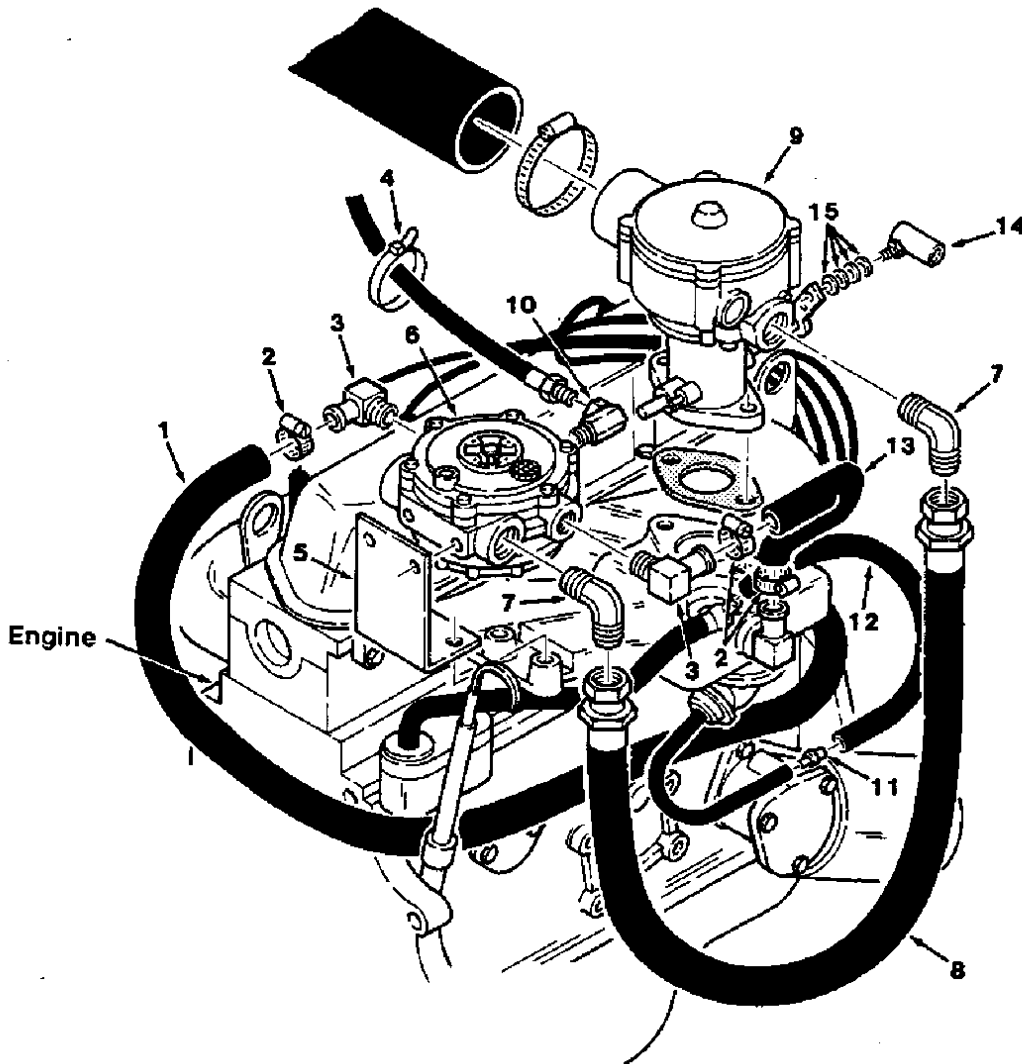

Fig. 2 - Carburetor Group, LPG

02541

Key	Tennant® Part No.	Machine Serial Number	Description	Qty.
1	82681	(000000-)	Hose	1
2	63810	(000000-)	Clamp, Worm Drive	4
3	51839	(000000-)	Fitting, Elbow	2
4	49263	(000000-)	Tie, Cable	3
5	82556	(000000-)	Bracket, Vaporizer	1
6	54930	(000000-)	Vaporizer, LPG	1
	55998	(000000-)	Repair Kit, Vaporizer	1
7	46611	(000000-)	Fitting, Elbow	2
8	82505	(000000-)	Hose, LPG	1
9	82691	(000000-)	Carburetor, LPG	1
10	11442-1	(000000-)	Fitting, Elbow	1
11	82684	(000000-)	Fitting, Straight	1
12	76589-2	(000000-)	Hose	1
13	57871	(000000-)	Hose	1
14	50332	(000000-)	Ball Joint	1
15	32483	(000000--)	Washer	4

NOTE: To identify parts shown but not listed here, see Section 5, Low Dump Model Parts.

SECTION 7 DIESEL PARTS

CONTENTS

	Page
Ordering Repair Parts	7-1
Fig. 1 - Engine Group, Diesel	7-2
Fig. 2 - Fuel Tank Group, Diesel	7-4
Fig. 3 - Radiator and Shroud Group, Diesel	7-6
Fig. 4 - Throttle Linkage Group, Diesel	7-7
Fig. 5 - Muffler Group, Diesel	7-8
Fig. 6 - Directional Control Group, Diesel ..	7-9
Fig. 7 - Instrument Panel Group, Diesel ...	7-10
Fig. 8 - Wire Harness Group, Diesel	7-11
Fig. 9 - Foam Insulation Group, Diesel	7-12
Fig.10 - Air Cleaner Group, Diesel	7-13

NOTE: Section 7, Diesel Parts, lists repair parts unique to a diesel powered machine.

Home

Find...

Go To..



ORDERING REPAIR PARTS

The components used in this machine have been carefully selected for performance and safety. Use only Tennant Company specified or equivalent parts.

To receive prompt service in filing of your parts orders, please direct all orders for parts with Tennant Company part numbers to the Tennant Company, and all orders for parts with vendor part numbers to the local supplier of the respective vendor.

When ordering parts, please furnish all of the following information:

1. Machine model number - shown on the machine data plate.

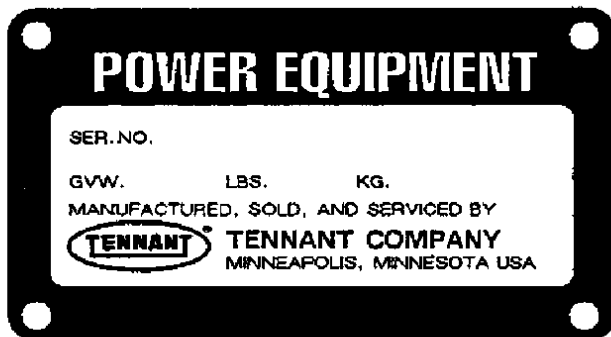

2. Machine serial number - shown on the machine data plate.
3. Power source - gasoline, LPG, diesel, electric.
4. Company name.
5. Shipping address.
6. Billing address.
7. Name, first and last - of person ordering parts.
8. Telephone number.
9. Purchase order number.
10. Part number, description, and quantity - of each item on the order.

Do not order parts by key number or the figure number of the illustrated parts. Indented items indicate parts of assemblies. Standard hardware is furnished only when part of a purchased assembly. Please get hardware from a local hardware supplier.

If the old part cannot be identified, send it to us with the quantity needed specified on the order.

Any claim for loss or damage to a shipment in transit should be filed promptly against the transportation company making the delivery. Shipments will be complete unless the packing list or order acknowledgement indicate items back ordered.

If parts received are suspected to be incorrect or defective, please write, wire, or phone the Tennant Company representative from whom you ordered the part. They will give authorization for return and/or handle replacement shipments when required.

SERIAL NUMBER INFORMATION EXPLANATION

Serial number listings are shown to indicate on which machines each part can be used. These listings are explained by the following examples:

(000000-) The part can be used on all machines.

(003342-) The part can be used on all machines beginning with the serial number listed.

(000000-004320) The part can be used on all machines up to and including serial number listed.

(004321-005678) The part can be used on all machines between and including the serial numbers listed.

Where xxxxx's are listed in place of a serial number, it indicates a change was made but the exact serial number had not been established when the catalog went to press.

SI UNITS OF MEASURE (INTERNATIONAL SYSTEM)

Metric equivalents have been included, where applicable, throughout this parts catalog.

FASTENER STRENGTH IDENTIFICATION

Fasteners required to have high-strength qualities equivalent to SAE Grade 8 are identified throughout this catalog by the description GR 8. Unless identified by this description, all standard fasteners are SAE Grade 5.

(Specifications and design subject to change without notice.)

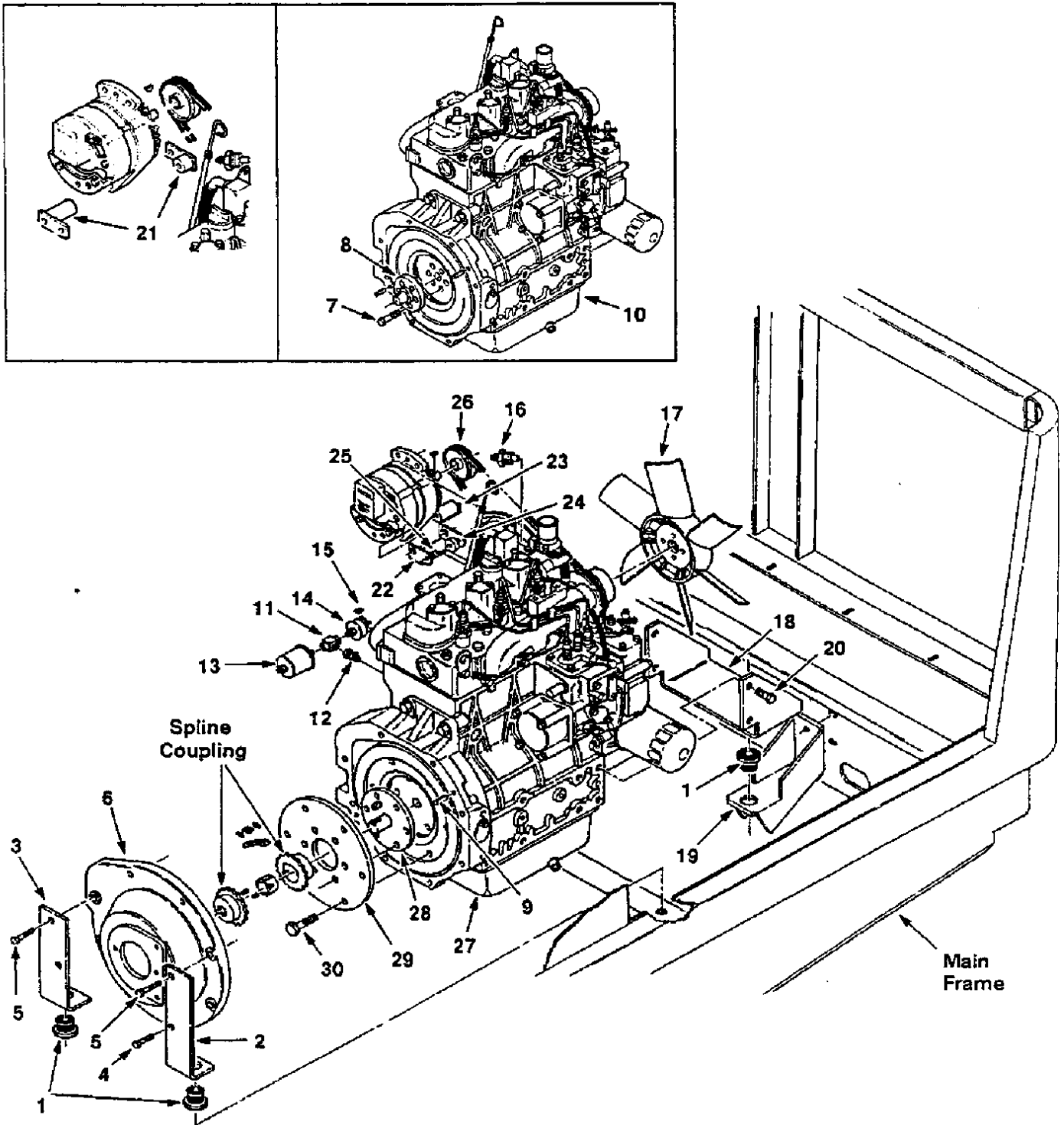

Fig. 1 - Engine Group, Diesel

NOTE: To identify parts shown but not listed here, see Section 5, Low Dump Model Parts.

Fig. 1 - Engine Group, Diesel

02724

Key	Tennant® Part No.	Machine Serial Number	Description	Qty.
1	51176	(000000-)	Dampener, Engine	3
2	82567	(000000-)	Mount, Engine	1
3	82566	(000000-)	Mount, Engine	1
4	82572	(000000-)	Screw, Hex, M10	2
5	82562	(000000-)	Screw, Hex, M10	4
6	82557	(000000-)	Housing, Flywheel	1
7	82574	(000000-003456)	Screw, Hex, M12	6
8	82569	(000000-003456)	Hub	1
9	82579	(000000-)	Pin, Spring	2
10	12032	(000000-003456)	Replacement Kit, Engine	1
11	02960	(000000-)	Fitting, Tee	1
12	02961	(000000-)	Fitting, Straight	1
13	34808	(000000-)	Sender, Oil Pressure	1
14	51805	(000000-)	Switch, Oil Pressure	1
15	68106	(000000-)	Terminal, Tab	3
16	82712	(000000-)	Sending Unit, Temperature	1
17	82537	(000000-)	Fan	1
18	82565	(000000-)	Mount, Engine	1
19	82594	(000000-)	Mount, Engine	1
20	82573	(000000-)	Screw, Hex, M12	4
21	02966	(000000-002529)	Service Kit, Alternator	1
22	02963	(002530-)	Bracket, Alternator	1
23	02964	(002530-)	Tube	1
24	02965	(002530-)	Sleeve	1
25	62797	(002530-)	Sleeve	1
26	24622	(000000-)	V-Belt	1
27	12033	(003457-)	Engine	1
28	07296	(003457-)	Shaft	1
29	07298	(003457-)	Ring	1
30	07299	(003457-)	Screw, Hex, M10	6

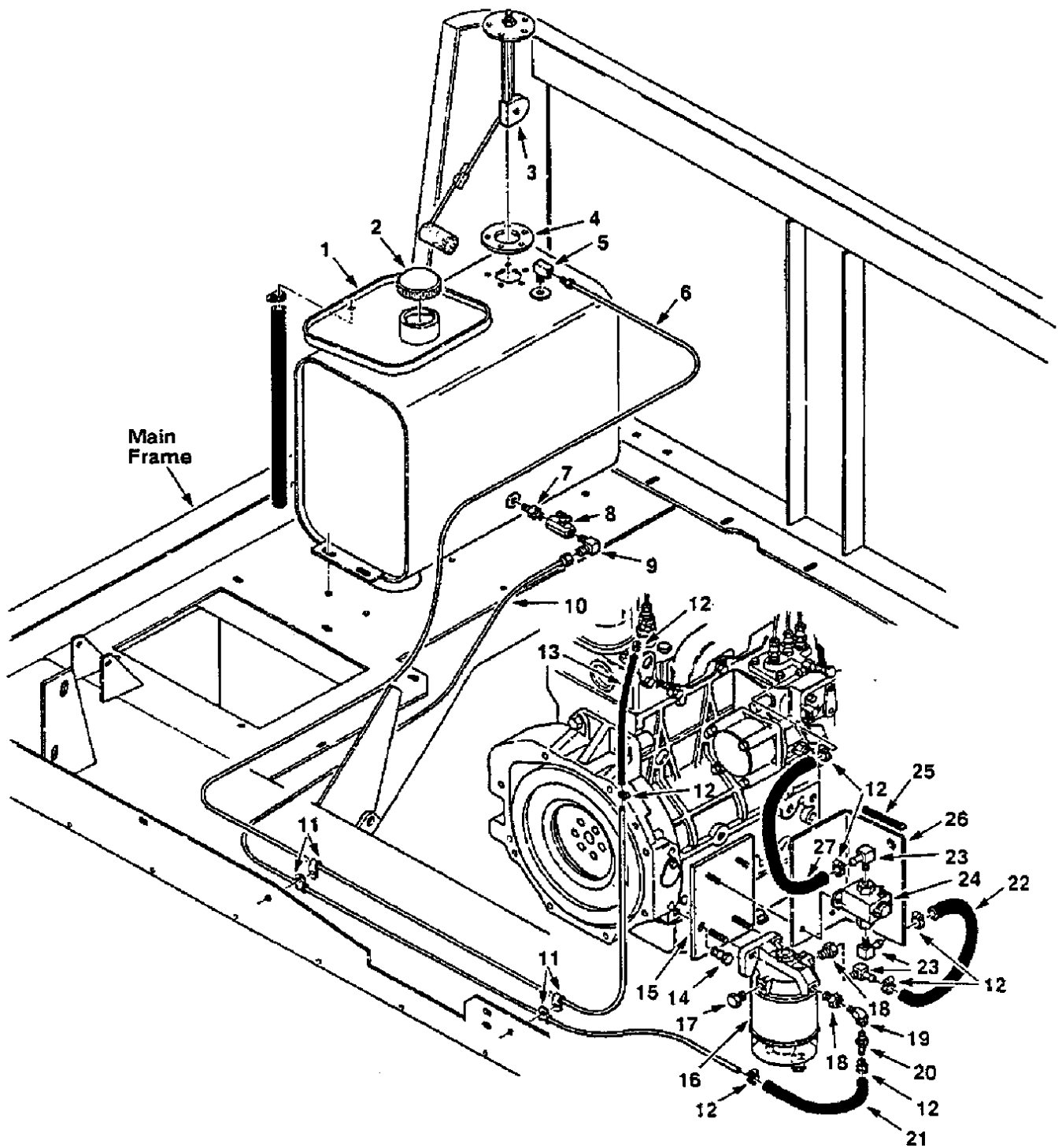

Fig. 2 - Fuel Tank Group, Diesel

NOTE: To identify parts shown but not listed here, see Section 5, Low Dump Model Parts.

Fig. 2 - Fuel Tank Group, Diesel

02725

Key	Tennant® Part No.	Machine Serial Number	Description	Qty.
1	82729	(000000-)	Tank, Fuel	1
2	48267	(000000-)	Cap. Gas	1
3	47473	(000000-)	Sending Unit, Tank	1
4	14131	(000000-)	Gasket	1
5	53078	(000000-)	Fitting, Elbow	1
6	82650	(000000-)	Tube Assembly	1
7	69736	(000000-001911)	Fitting, Straight	1
7	47566	(001912-)	Fitting, Straight	1
8	13988	(000000-001911)	Cock	1
8	08873	(001912-)	Valve, Ball	1
9	06507	(000000-)	Fitting, Elbow	1
10	02977	(000000-)	Line Assembly	1
11	46236	(000000-)	Clamp, Cable	4
12	43844	(000000-)	Clamp, Worm Drive	8
13	82689	(000000-)	Hose, Rubber	1
14	82573	(000000-)	Screw, Hex, M12	2
15	82513	(000000-)	Plate, Mounting	1
16	82682	(000000-)	Filter, Fuel/water Separator	1
	82692	(000000-)	Element, Filter	1
17	02247	(000000-)	Fitting, Plug	1
18	17414	(000000-)	Fitting, Straight	2
19	24976	(000000-)	Fitting, Elbow, 45°	1
20	48253	(000000-)	Fitting, Straight	1
21	82686	(000000-)	Hose	1
22	82509	(000000-)	Hose	1
23	53029	(000000-)	Fitting, Elbow	3
24	54230	(000000-)	Pump, Fuel	1
25	50850	(000000-)	Molding, Rigid	1
26	82512	(000000-)	Bracket, Mounting	1
27	82510	(000000-)	Hose	1

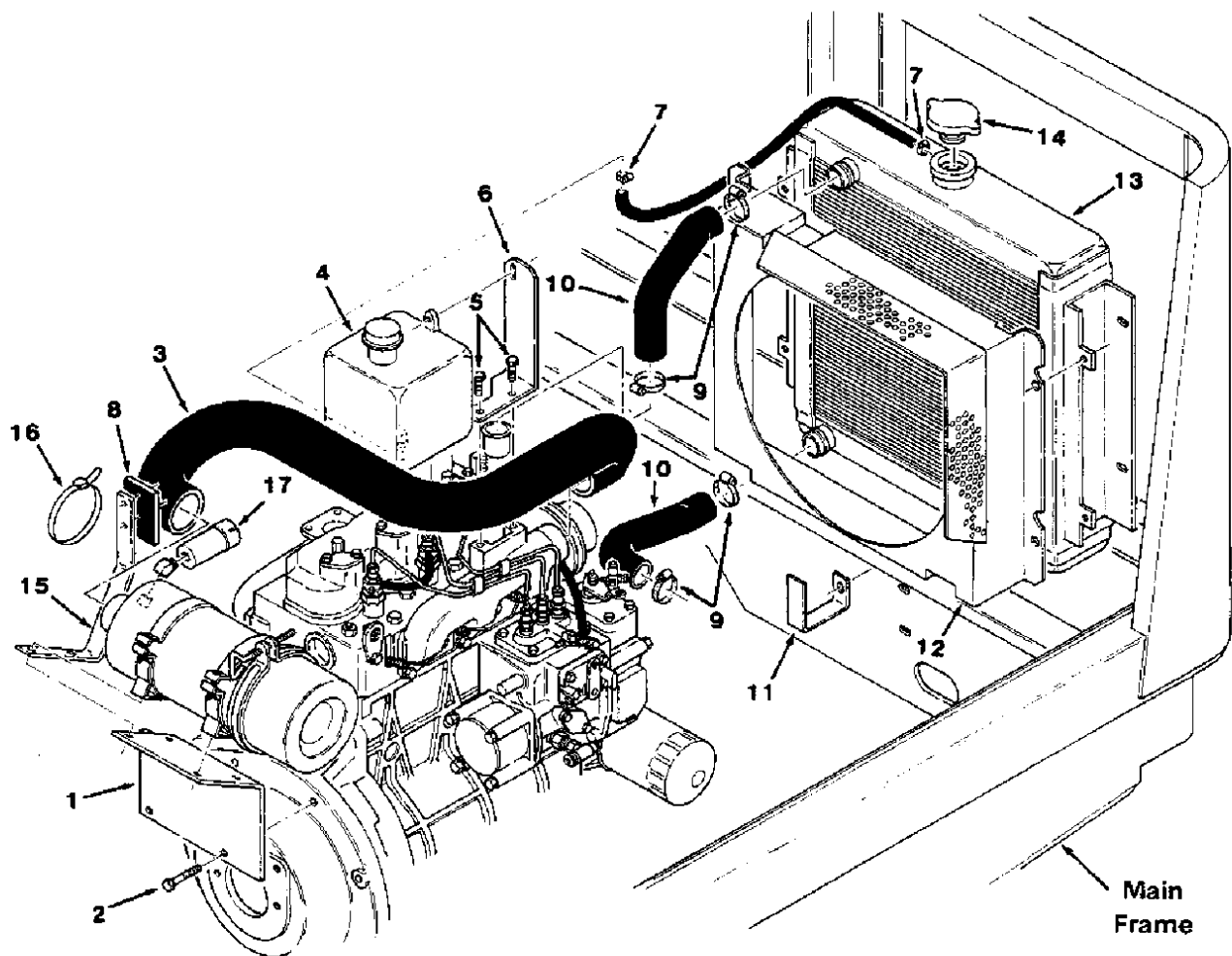



Fig. 3 - Radiator and Shroud Group, Diesel

02734

Key	Tennant® Part No.	Machine Serial Number	Description	Qty.
1	82596	(000000-)	Bracket, Air Cleaner	1
2	82572	(000000-)	Screw, Hex, M10	2
3	82598	(000000-)	Hose, Intake	1
4	82694	(000000-)	Tank, Coolant Recovery	1
5	16931	(000000-)	Screw, Hex, M8	5
6	82696	(000000-)	Bracket, Tank	1
7	43844	(000000-)	Clamp, Worm Drive	2
8	06913	(002531-)	Pad, Rubber	1
9	11531	(000000-)	Clamp, Worm Drive	4
10	82553	(000000-)	Hose, Radiator	2
11	82547	(000000-)	Retainer	1
12	82257	(000000-)	Shroud Assembly, Fan	1
13	82653	(000000-)	Radiator	1
14	82688	(000000-)	Cap, Radiator	1
	07674	(000000-)	Drain Cock, Radiator	1
15	03020	(000000-)	Support	1
16	44961	(000000-)	Tie, Cable	1
17	03026	(000000-)	Indicator, Air Filter Service	1

NOTE: To identify parts shown but not listed here, see Section 5, Low Dump Model Parts.

Home Find... Go To..  

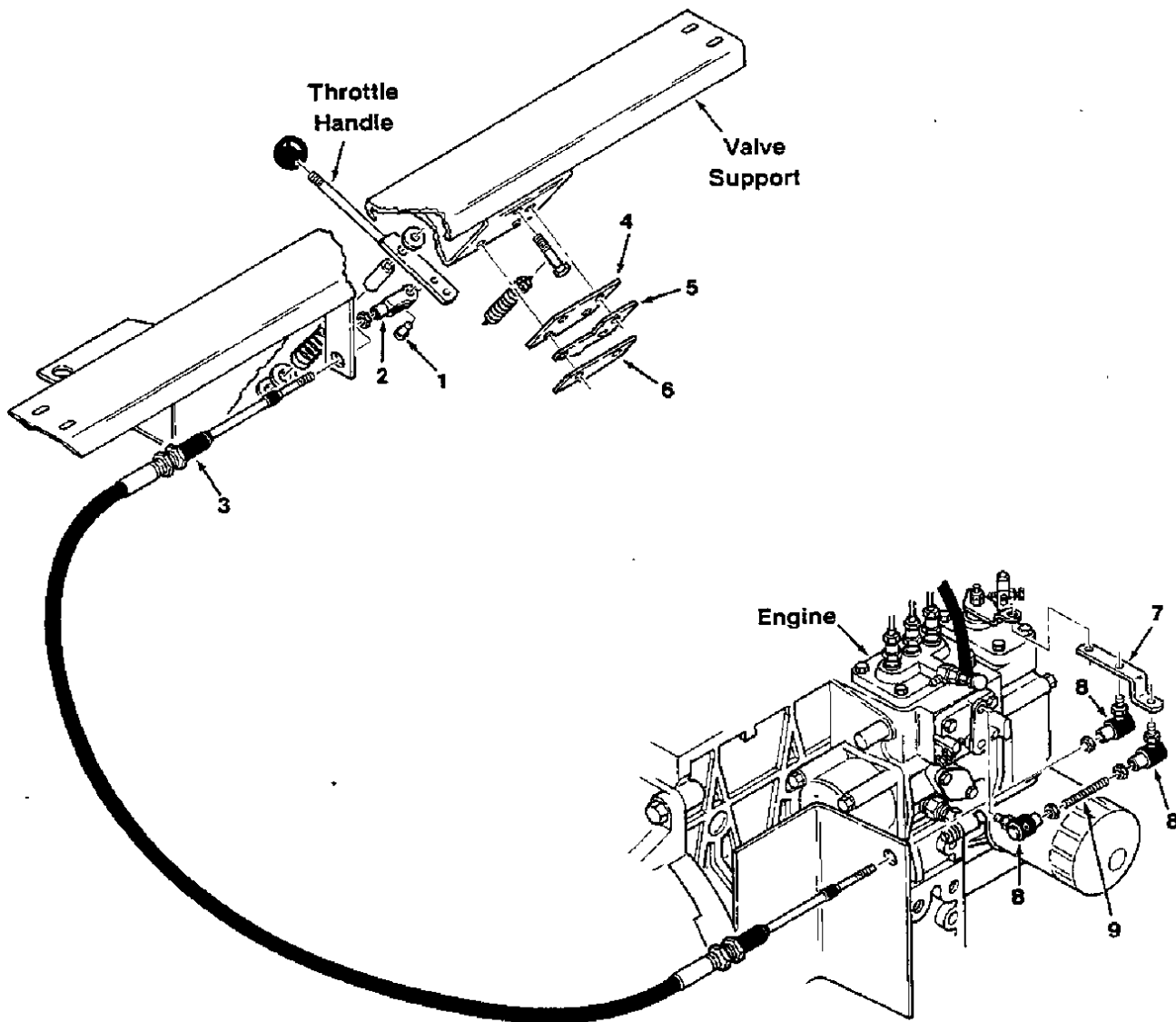

Fig. 4 - Throttle Linkage Group, Diesel

02723

Key	Tennant® Part No.	Machine Serial Number	Description	Qty.
1	14605	(000000-)	Pin, Clevis	1
2	14595-1	(000000-)	Clevis, Adjustable	1
3	69494-2	(000000-)	Cable Assembly	1
4	82677	(000000-)	Plate, Stop	1
5	82563	(000000-)	Plate, Stop	1
6	82564	(000000-)	Plate, Stop	1
7	82597	(000000-)	Link, Throttle	1
8	14601	(000000-)	Ball Joint	3
9	42196	(000000-)	Stud	1

NOTE: It identify parts shown but not listed here, see Section 5, Low Dump Model Parts.

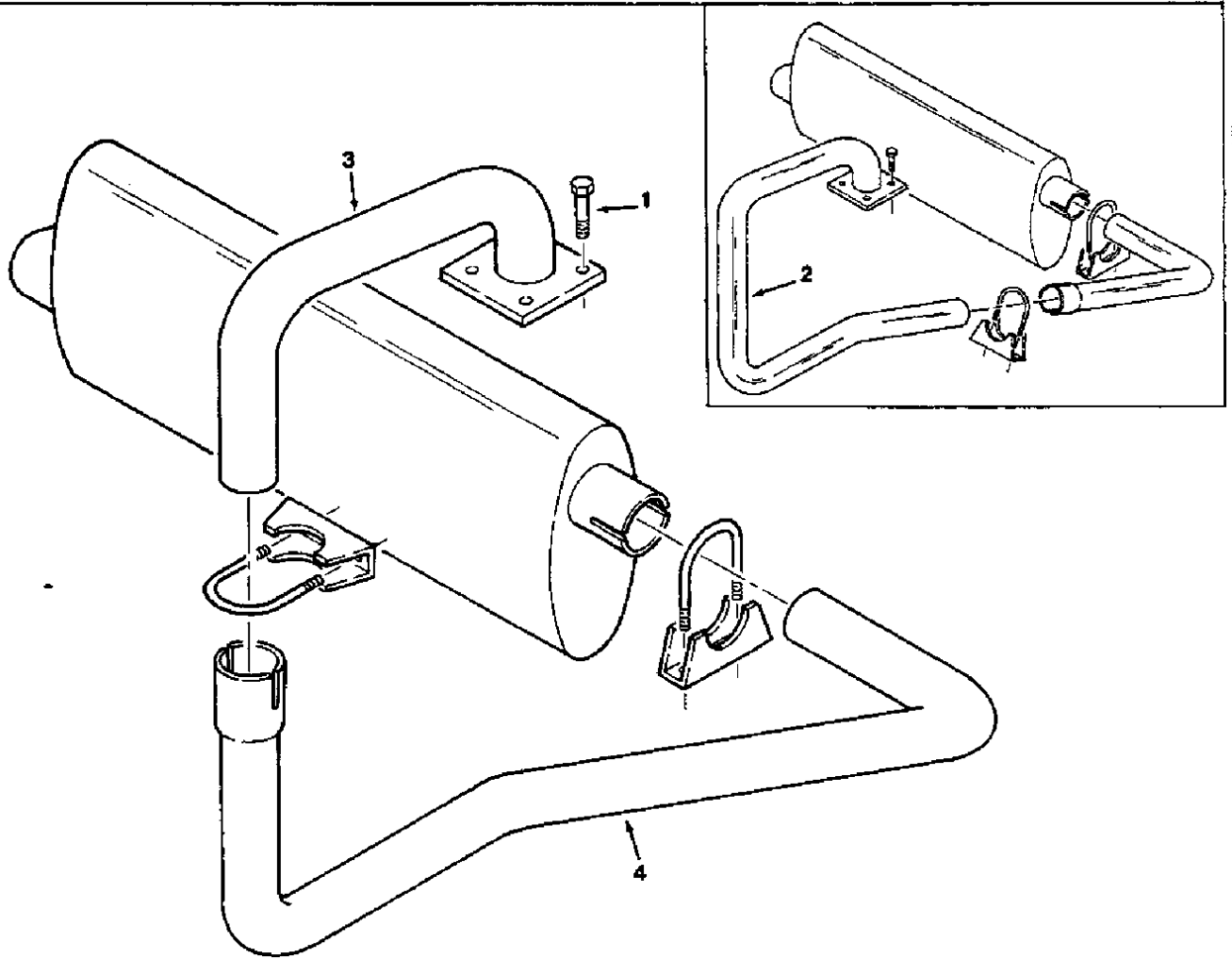

Fig. 5 - Muffler Group, Diesel

02721

Key	Tennant® Part No.	Machine Serial Number	Description	Qty.
1	16931	(000000-)	Screw, Hex, M8	4
2	82263	(000000-002883)	Replacement Kit, Exhaust Pipe	1
3	82628	(002884-)	Pipe, Exhaust	1
4	82629	(002884-)	Pipe, Exhaust	1

NOTE: To identify parts shown but not listed here, see Section 5, Low Dump Model Parts.

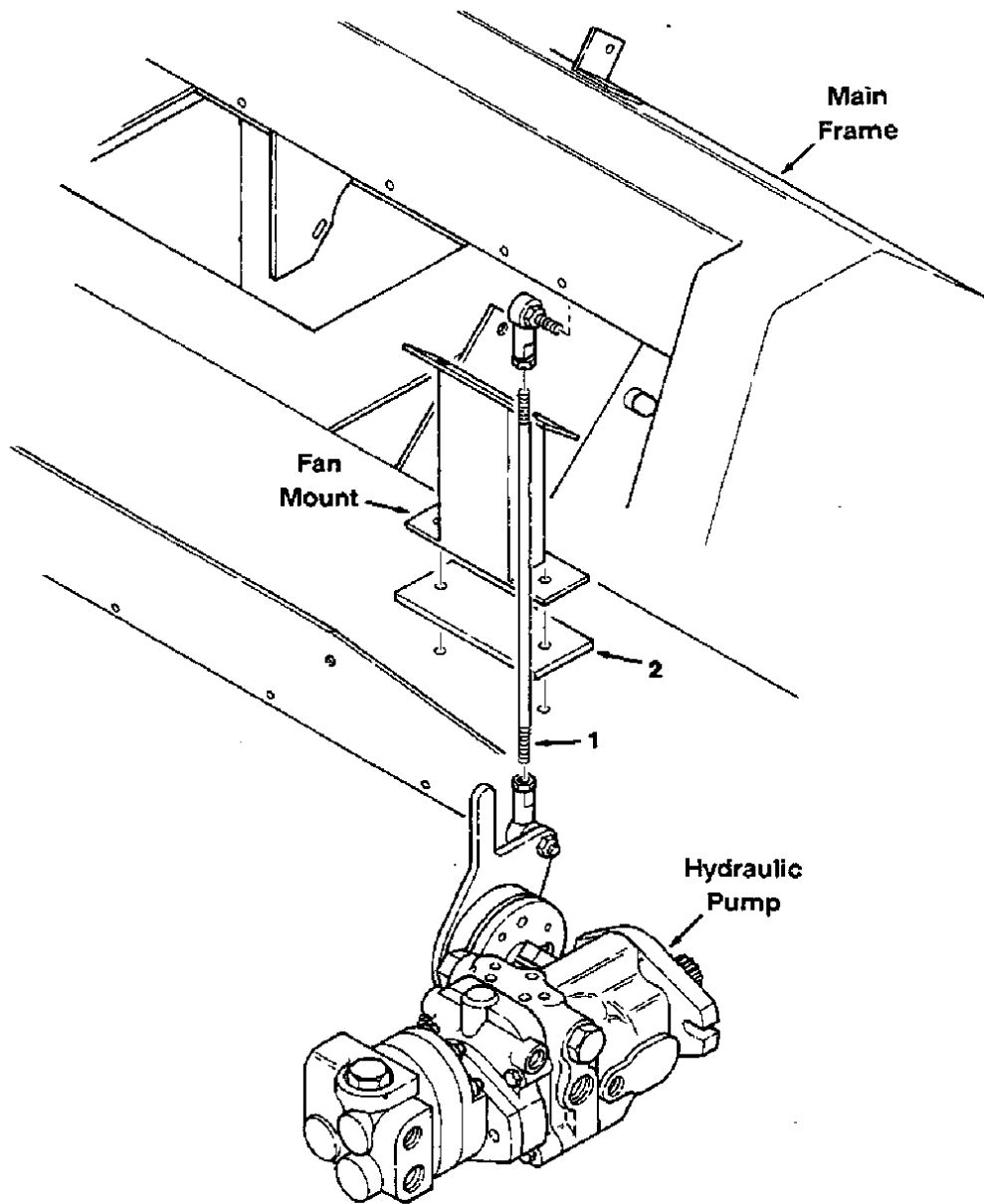

Fig. 6 - Directional Control Group, Diesel

02722

Key	Tennant® Part No.	Machine Serial Number	Description	Qty.
1	82210	(000000-)	Stud	1
2	33796	(000000-)	Spacer, Vacuum Fan	1

NOTE: To identify parts shown but not listed here, see Section 5, Low Dump Model Parts.

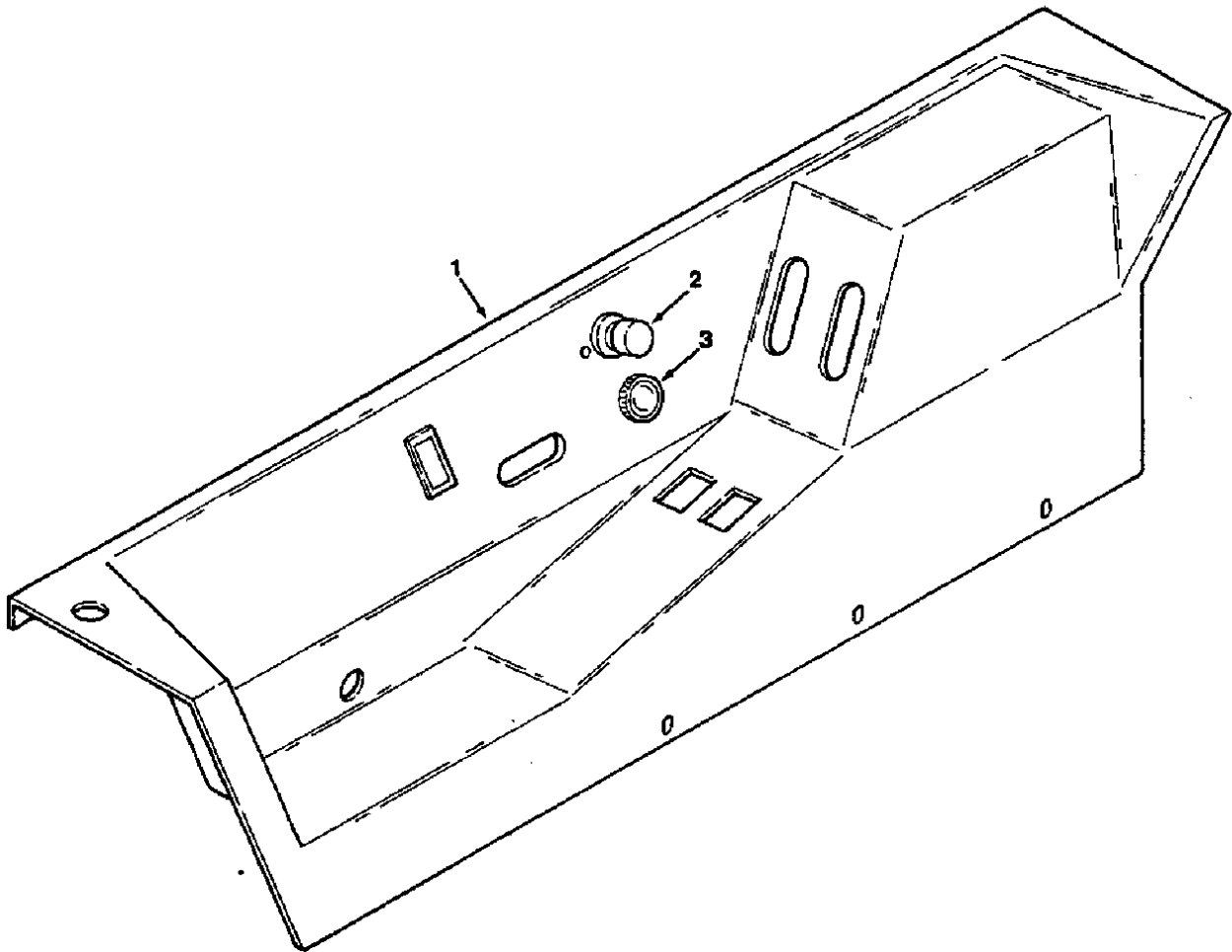

Fig. 7 - Instrument Panel Group, Diesel

02719

Key	Tennant® Part No.	Machine Serial Number	Description	Qty.
1	82349	(000000-)	Panel, Control	1
2	44078	(000000-)	Switch	1
3	82715	(000000-)	Indicator, Glow Plug	1

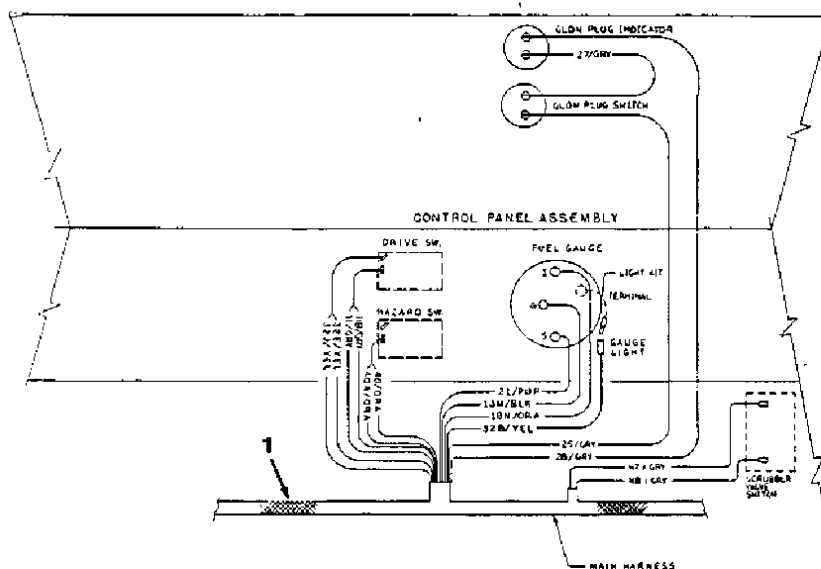
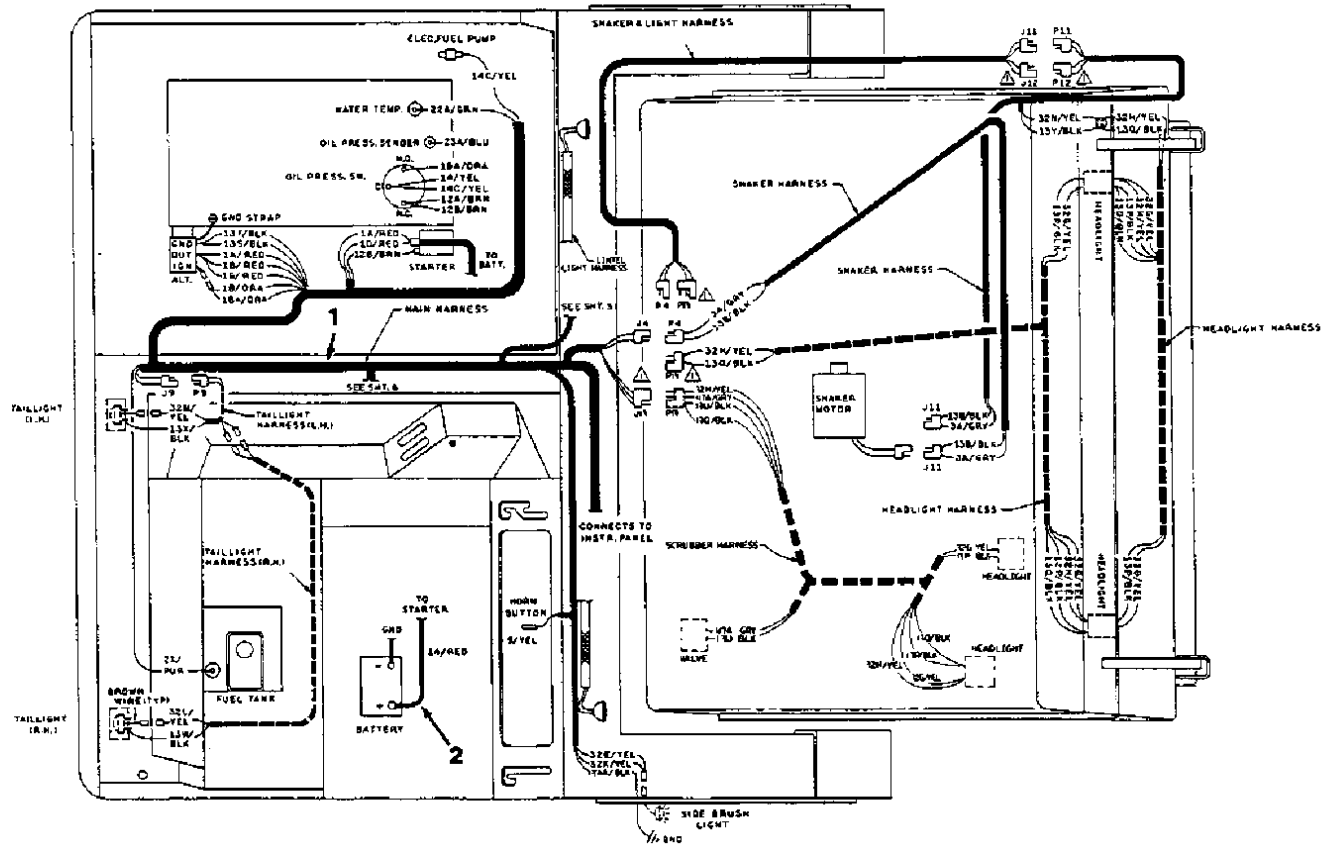

Fig. 8 - Wire Harness Group, Diesel

Key	Tennant® Part No.	Machine Serial Number	Description	Qty.
1	82703	(000000-)	Wire Harness, Main	1
	45975	(000000-)	Fuse, Glow Plug	1
2	82710	(000000-)	Wire Assembly, Positive Battery	1

NOTE: To identify parts shown but not listed here, see Section 5, Low Dump Model Parts.

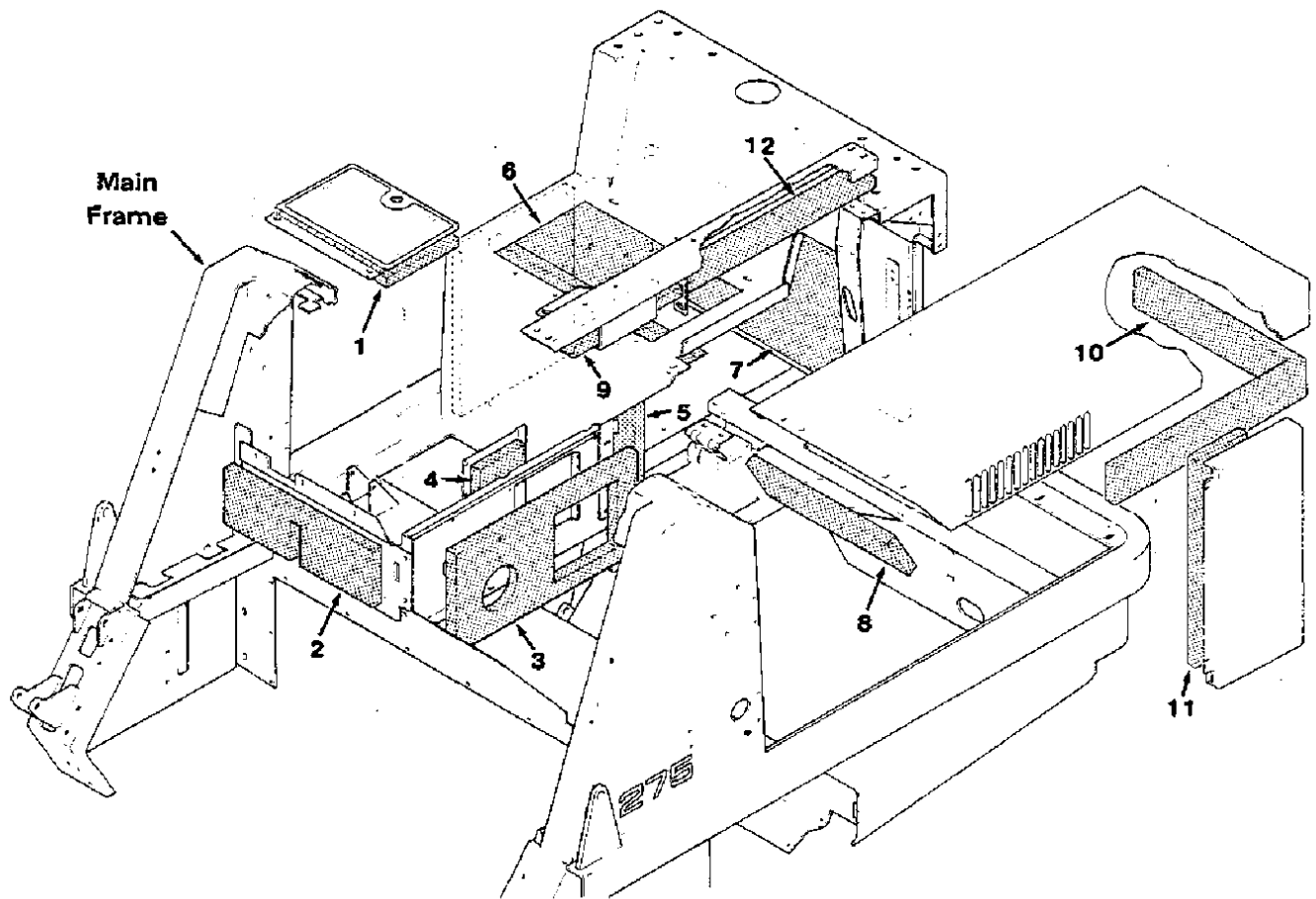

Fig. 9 - Foam Insulation Group, Diesel

02928

Key	Tennant® Part No.	Machine Serial Number	Description	Qty.
1	03069	(000000-)	Insulation, Foam	1
2	03071	(000000-)	Insulation, Foam	1
3	03072	(000000-)	Insulation, Foam	1
4	03070	(000000-)	Insulation, Foam	1
5	03067	(000000-)	Insulation, Foam	1
6	03056	(000000-)	Insulation, Foam	1
7	03058	(000000-)	Insulation, Foam	1
8	03053	(000000-)	Insulation, Foam	1
9	03055	(000000-)	Insulation, Foam	1
10	03051	(000000-)	Insulation, Foam	1
11	03068	(000000-)	Insulation, Foam	1
12	03054	(000000-)	Insulation, Foam	1

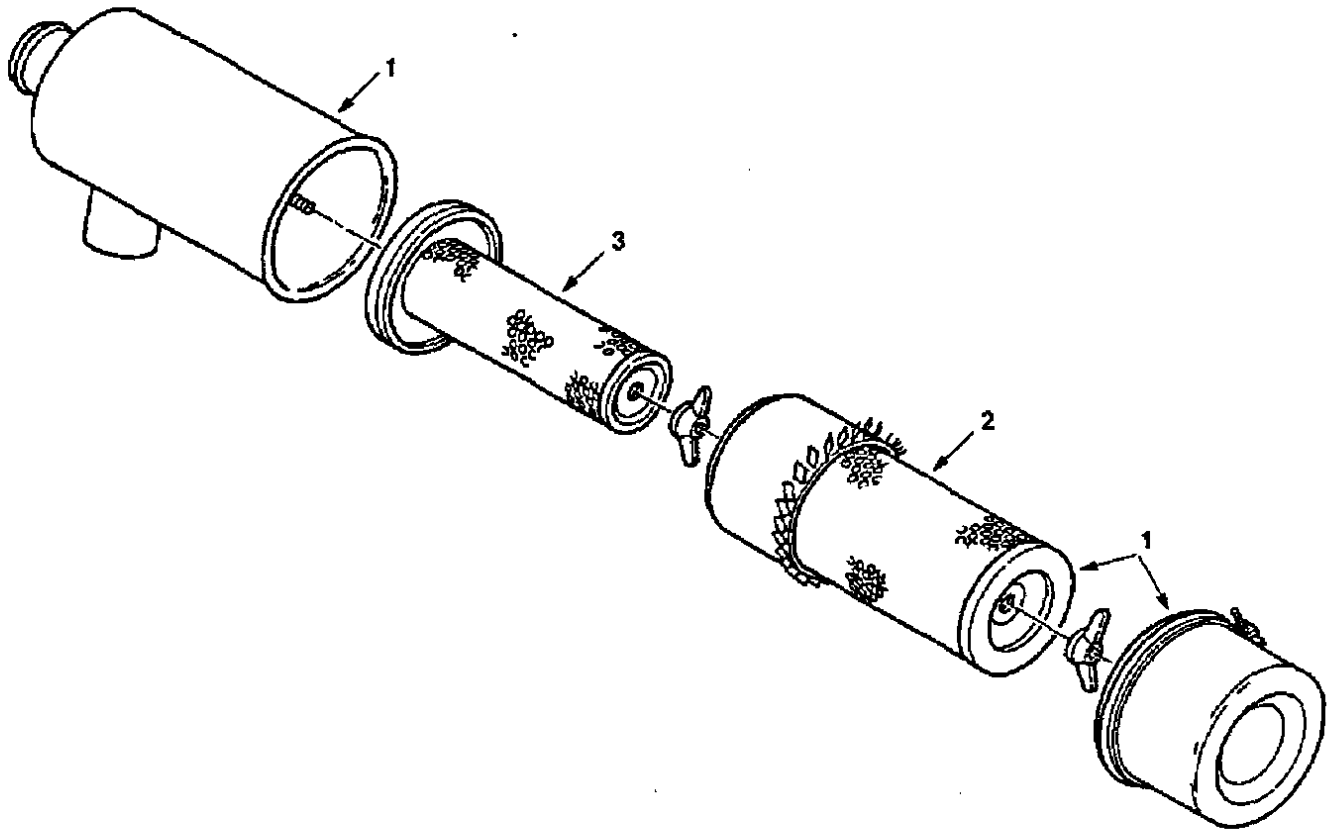

Fig. 10 - Air Cleaner Group, Diesel

02274

Key	Tennant® Part No.	Machine Serial Number	Description	Qty.
1	58539	(000000-)	Air Cleaner, Heavy Duty	1
2	58538	(000000-)	Body, Air Cleaner	1
3	58120	(000000-)	Element, Air Cleaner	1
	58121	(000000-)	Element, Safety	1

SECTION 8

MULTI-LEVEL DUMP MODEL PARTS

CONTENTS

	Page
Ordering Repair Parts	8-1
Fig. 1 - Main Frame Group, Multi-Level Dump	8-2
Fig. 2 - Hopper Door Assembly, Multi-Level Dump	8-3
Fig. 3 - Hopper Group, Multi-Level Dump .	8-4
Fig. 4 - Hopper Lift Arms Group, Multi-Level Dump	8-6
Fig. 5 - Hopper Cover and Filter Carrier Group, Multi-Level Dump	8-8
Fig. 6 - Hydraulic Lift Cylinder Group, Multi-Level Dump	8-9
Fig. 7 - Stabilizer Leg Group, Multi-Level Dump	8-10
Fig. 8 - Side Brush Group, Multi-Level Dump	8-11
Fig. 9 - Main Brush Lift Group, Multi-Level Dump	8-12
Fig. 10 - Front Wheel and Brakes Group, Multi-Level Dump	8-13
Fig. 11 - Hydraulic Hoses Group, Multi-Level Dump	8-14
Fig. 12 - Hydraulic Control Valve Group, Multi-Level Dump	8-15
Fig. 13 - Throttle Linkage Group Multi-Level Dump	8-16
Fig. 14 - Wire Harnesses Group, Multi-Level Dump	8-17

NOTE: Section 8, Multi-Level Dump Model Parts, lists repair parts unique to a multi-level dump Model 275.

ORDERING REPAIR PARTS

The components used in this machine have been carefully selected for performance and safety. Use only Tennant Company specified or equivalent parts.

To receive prompt service in filling of your parts orders, please direct all orders for parts with Tennant Company part numbers to the Tennant Company, and all orders for parts with vendor part numbers to the local supplier of the respective vendor.

When ordering parts, please furnish all of the following information:

1. Machine model number - shown on the machine data plate.

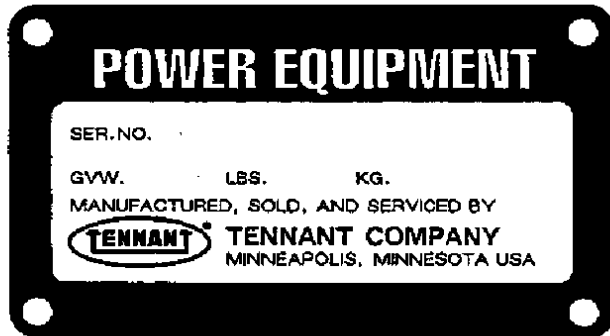

2. Machine serial number - shown on the machine data plate.
3. Engine type - gasoline, LPG, diesel, electric.
4. Company name.
5. Shipping address.
6. Billing address.
7. Name, first and last - of person ordering parts.
8. Telephone number.
9. Purchase order number.
10. Part number, description, and quantity - of each item on the order.

Do not order parts by key number or the figure number of the illustrated parts. Indented items indicate parts of assemblies. Standard hardware is furnished only when part of a purchased assembly. Please get hardware from a local hardware supplier.

If the old part cannot be identified, send it to us with the quantity needed specified on the order.

Any claim for loss or damage to a shipment in transit should be filed promptly against the transportation company making the delivery. Shipments will be complete unless the packing list or order acknowledgement indicate items back ordered.

If parts received are suspected to be incorrect or defective, please write, wire, or phone the Tennant Company representative from whom you ordered the part. They will give authorization for return and/or handle replacement shipments when required.

SERIAL NUMBER INFORMATION EXPLANATION

Serial number listings are shown to indicate on which machines each part can be used. These listings are explained by the following examples:

(000000-) The part can be used on all machines.

(003342-) The part can be used on all machines beginning with the serial number listed.

(000000-004320) The part can be used on all machines up to and including serial number listed.

(004321-005678) The part can be used on all machines between and including the serial numbers listed.

Where xxxxx's are listed in place of a serial number, it indicates a change was made but the exact serial number had not been established when the catalog went to press.

SI UNITS OF MEASURE (INTERNATIONAL SYSTEM)

Metric equivalents have been included, where applicable, throughout this parts catalog.

FASTENER STRENGTH IDENTIFICATION

Fasteners required to have high-strength qualities equivalent to SAE Grade 8 are identified throughout this catalog by the description GR 8. Unless identified by this description, all standard fasteners are SAE Grade 5.

(Specifications and design subject to change without notice.)

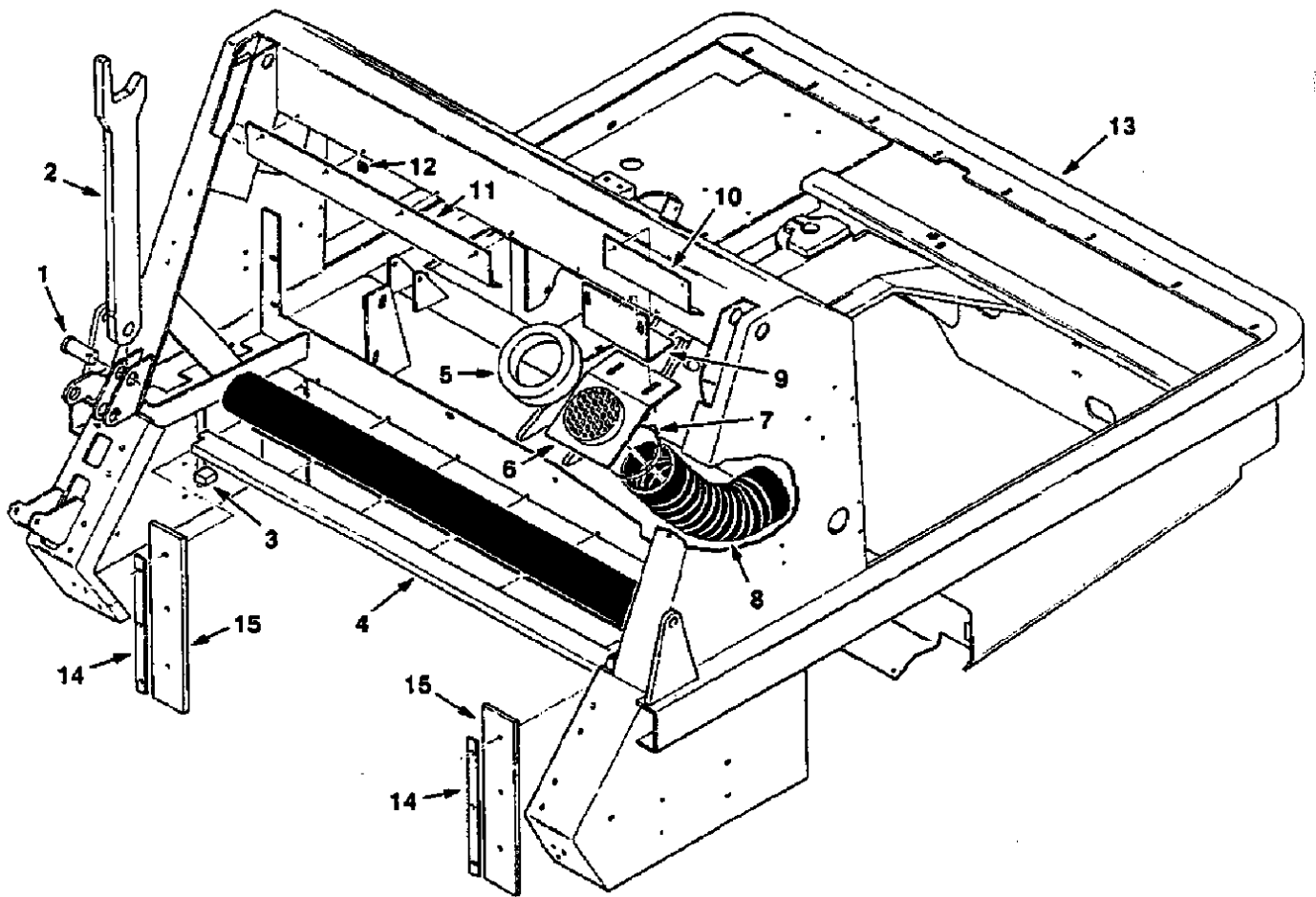

Fig. 1 - Main Frame Group, Multi-Level Dump

02706

Key	Tennant® Part No.	Machine Serial Number	Description	Qty.
1	36994	(000000-)	Pin, Clevis	1
2	82193	(000000-)	Arm Assembly, Safety	1
3	54338-6	(000000-)	Seal, Foam Rubber	2
4	50446	(000000-)	Retainer, Top Seal	1
5	82425	(000000-)	Seal, Fan Inlet	1
6	82393	(000000-)	Connection, Hose	1
7	23498	(000000-)	Clamp, Worm Drive	1
8	51768A	(000000-)	Hose	1
9	82394	(000000-)	Angle, Hose Adjust	1
10	82776	(000000-)	Shield, Spray	1
11	82777	(000000-)	Shield, Spray	1
12	82138	(000000-)	Nut, Retainer	6
13	82150	(000000-)	Frame, Main	1
14	23384-2	(000000-)	Strip	2
15	23382	(000000-)	Seal, Side	6

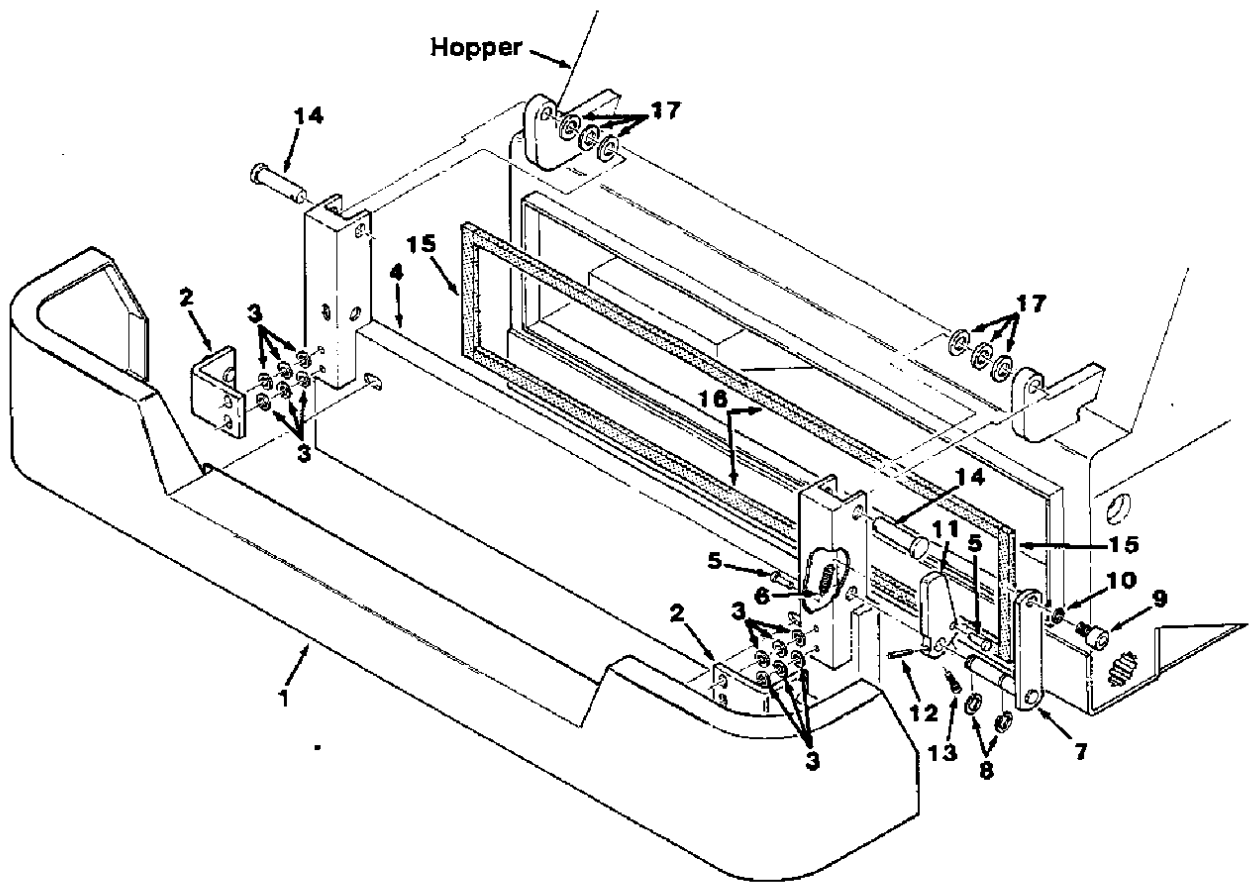

Fig. 2 - Hopper Door Assembly, Multi-Level Dump

02705

Key	Tennant® Part No.	Machine Serial Number	Description	Qty.
1	82496	(000000-)	Bumper	1
2	36984	(000000-)	Bracket, Door Latch	2
3	32492	(000000-)	Washer	12
4	35669	(000000-)	Door Assembly, Hopper	1
	35526	(000000-)	Door, Hopper	1
5	82168	(000000-)	Pin, Clevis	2
6	28387	(000000-)	Spring, Tension	1
7	37073	(000000-)	Shaft, Pivot	1
8	23788-1	(000000-)	Ring, Retaining	2
9	48930	(000000-)	Cam, Follower	1
10	35546	(000000-)	Sleeve	1
11	37074	(000000-)	Brace, Hopper Door	1
12	46585	(000000-)	Pin, Roll	1
13	01681	(000000-)	Screw, Socket	1
14	04733-3	(000000-)	Pin, Clevis	2
15	37055	(000000-)	Seal, Foam Rubber	2
16	37054	(000000-)	Seal, Foam Rubber	2
17	35540	(000000-)	Shim, Washer	6

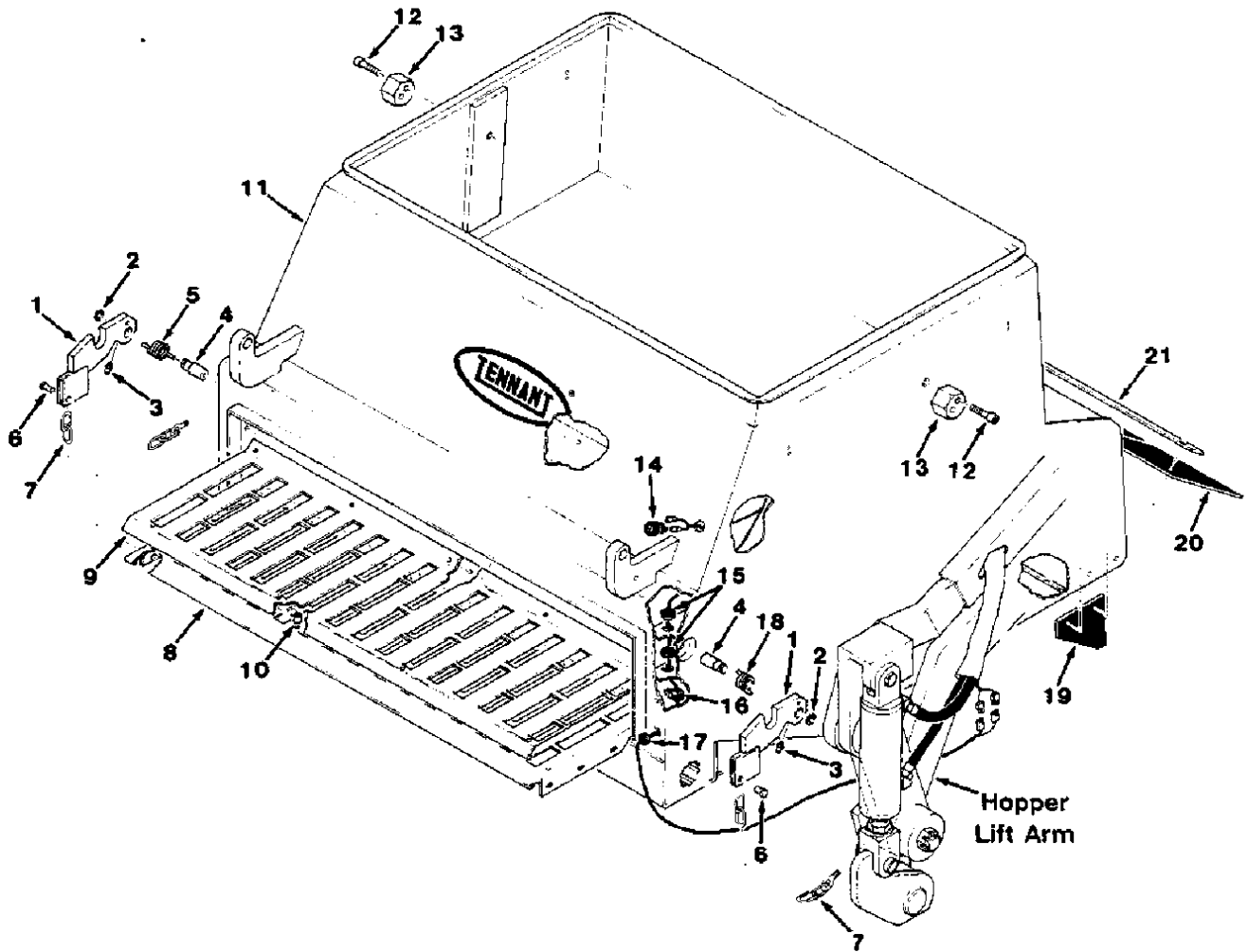

Fig. 3 - Hopper Group, Multi-Level Dump

Fig. 3 - Hopper Group, Multi-Level Dump

02564

Key	Tennant® Part No.	Machine Serial Number	Description	Qty.
1	82501	(000000-)	Latch, Door	2
2	18136	(000000-)	Ring, Retaining	2
3	07259	(000000-)	Fitting, Grease	2
4	82500	(000000-)	Shaft, Latch	2
5	48928	(000000-)	Spring, Torsion	1
6	10120	(000000-)	Pin, Clevis	2
7	32448	(000000-)	Chain Assembly	2
8	82476	(000000-)	Baffle, Lower	1
9	82477	(000000-)	Baffle, Upper	1
10	82483	(000000-)	Tube, Spacer	4
11	08000	(000000-)	Hopper	1
12	82423	(000000-)	Screw, Socket	2
13	82421	(000000-)	Cam, Positioning	2
14	39672	(000000-)	Terminal, Bushing	1
15	10632-4	(000000-)	Grommet	2
16	26395-2	(000000-)	Clamp, Cable	1
17	10632-1	(000000-)	Grommet	1
18	48927	(000000-)	Spring, Torsion	1
19	37021	(000000-)	Lip, Side	2
20	35607	(000000-)	Lip	5
21	53758	(000000-)	Strip	1

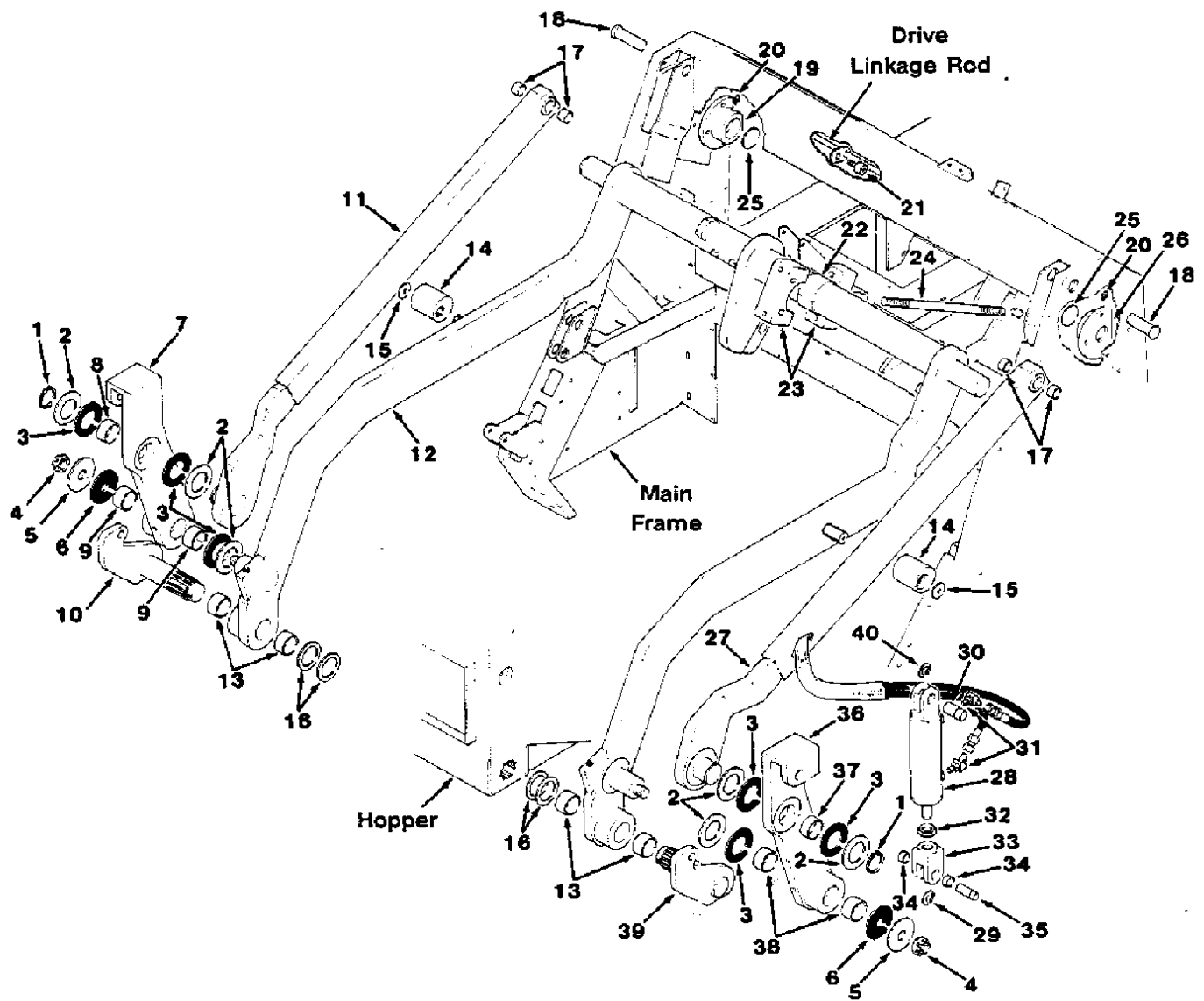

Fig. 4 - Hopper Lift Arms Group, Multi-Level Dump

Fig. 4 - Hopper Lift Arms Group, Multi-Level Dump

02562

Key	Tennant® Part No.	Machine Serial Number	Description	Qty.
1	35686	(000000-)	Ring, Retaining	2
2	35615	(000000-)	Washer	6
3	37139	(000000-)	Bearing, Thrust	6
4	14242	(000000-)	Nut, Slotted	2
5	35614	(000000-)	Washer	2
6	35666	(000000-)	Bearing, Thrust	2
7	35621-1	(000000-)	Arm Assembly, Pivot, R.H.	1
8	35665	(000000-)	Bearing, Journal	1
9	35561	(000000-)	Bearing, Journal	2
10	35640	(000000-)	Shaft, R.H.	1
11	82610	(000000-)	Arm, Upper, R.H.	1
12	82194	(000000-)	Arm Assembly, Lift	1
13	35561	(000000-)	Bearing, Journal	4
14	33541	(000000-)	Hub, Splined	2
15	36996	(000000-)	Washer	2
16	32125	(000000-)	Washer	6
17	35688	(000000-)	Bearing, Journal	4
18	34410	(000000-)	Pin, Clevis	2
19	35631	(000000-)	Bearing, R.H.	1
20	07259	(000000-)	Fitting, Grease	2
21	48930	(000000-)	Cam, Follower	1
22	35668	(000000-)	Bearing, Journal	1
23	35630	(000000-)	Bearing, Center	1
24	35595	(000000-)	Stud	1
25	23138	(000000-)	Shim	6
26	35631-1	(000000-)	Bearing, L.H.	1
27	82611	(000000-)	Arm, Upper, L.H.	1
28	82756	(000000-)	Cylinder, Hydraulic	2
29	23788-1	(000000-)	Ring, Retaining	2
30	23145	(000000-)	Pin, Grooved	2
31	34359	(000000-)	Fitting, Elbow, 45°	4
32	48988	(000000-)	Nut	2
33	37015	(000000-)	Clevis	2
34	37014	(000000-)	Bearing, Journal	2
35	37016	(000000-)	Pin, Grooved	2
36	35620-1	(000000-)	Arm Assembly, Pivot, L.H.	1
37	35665	(000000-)	Bearing, Journal	1
38	35561	(000000-)	Bearing, Journal	2
39	35636	(000000-)	Shaft, L.H.	1
40	23788	(000000-)	Ring, Retaining	2

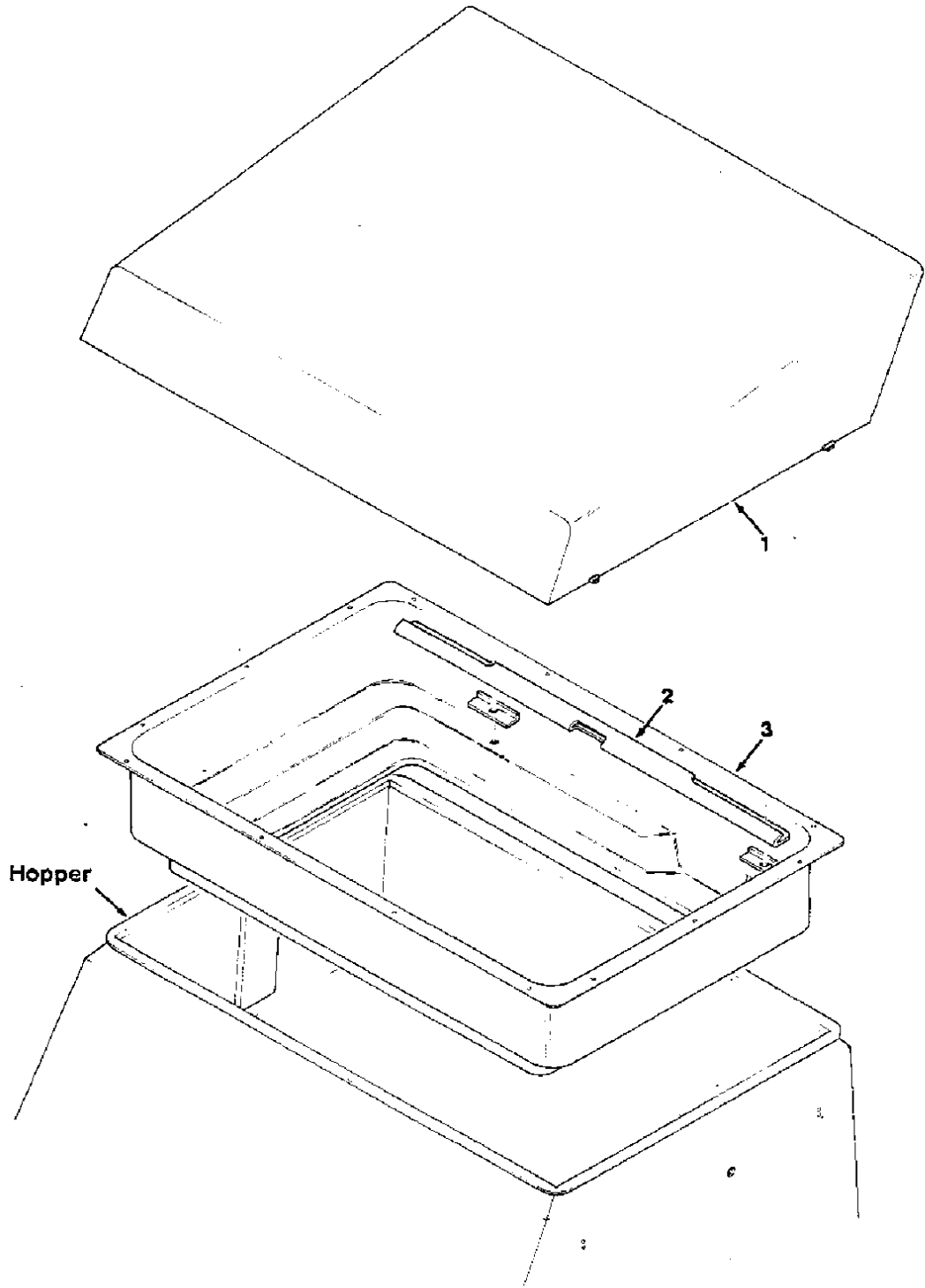

Fig. 5 - Hopper Cover and Filter Carrier Group, Multi-Level Dump

02573

Key	Tennant® Part No.	Machine Serial Number	Description	Qty.
1	82400	(000000-)	Cover, Filter	1
2	82452	(000000-)	Bracket, Filter Retainer	1
3	82451	(000000-)	Carrier, Filter	1

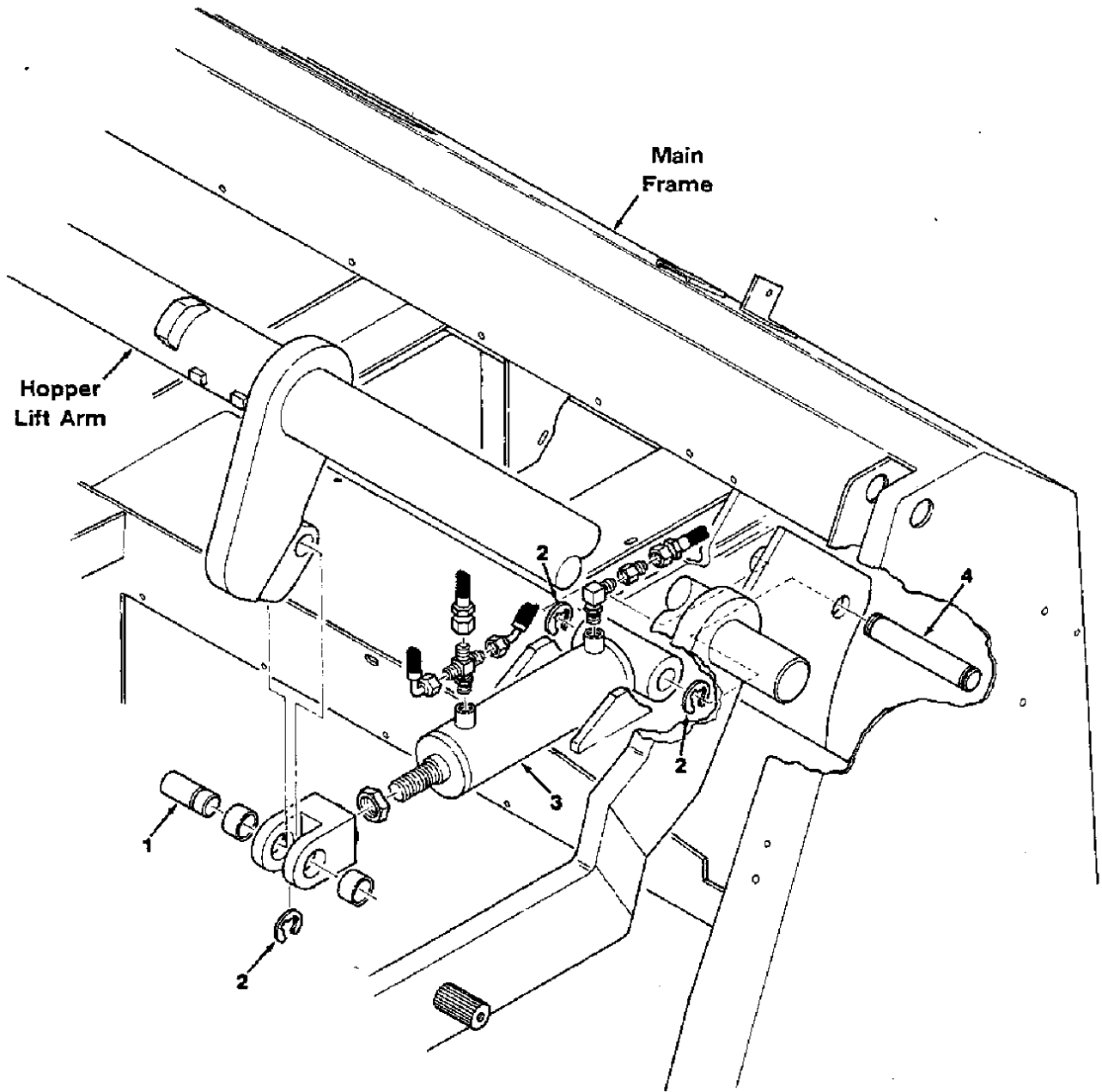

Fig. 6 - Hydraulic Lift Cylinder Group, Multi-Level Dump

02548

Key	Tennant® Part No.	Machine Serial Number	Description	Qty.
1	32941	(000000-)	Pin, Grooved	1
2	23788	(000000-)	Ring, Retaining	3
3	82757	(000000-)	Cylinder, Hydraulic	1
4	35515	(000000-)	Pin, Grooved	1

NOTE: To identify parts shown but not listed here, see Section 5, Low Dump Model Parts.

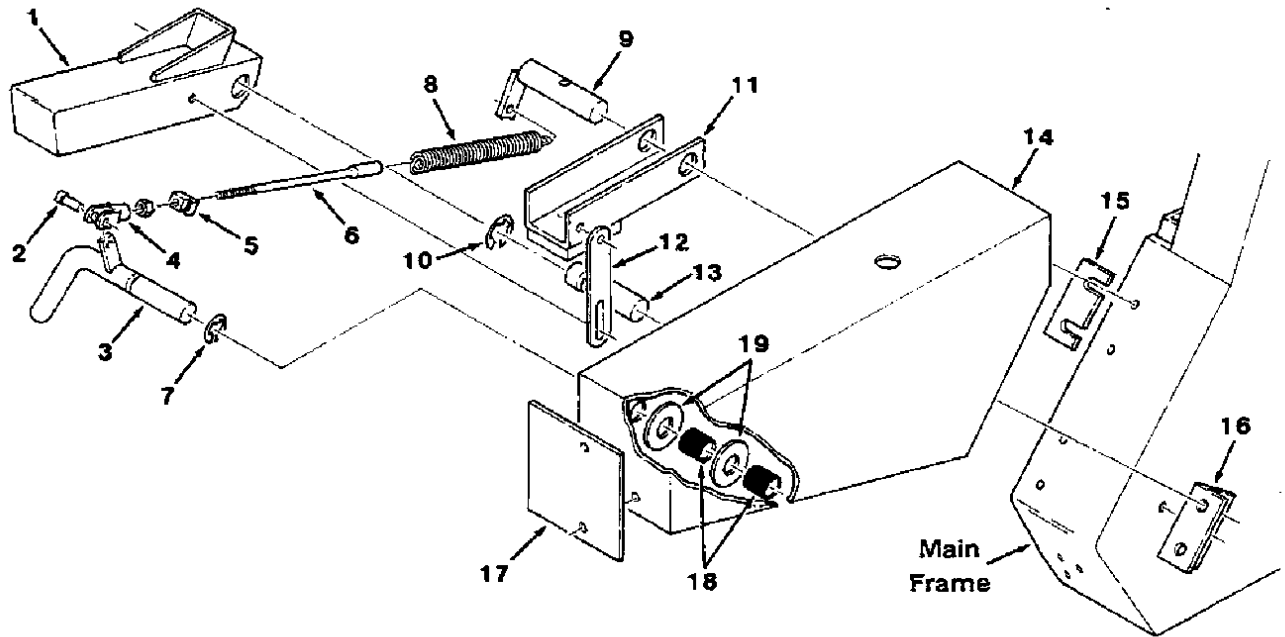

Fig. 7 - Stabilizer Leg Group, Multi-Level Dump

02564

Key	Tennant® Part No.	Machine Serial Number	Description	Qty.
1	35591	(000000-)	Leg, Safety	1
2	51727	(000000-)	Pin, Clevis	1
3	33568	(000000-)	Lever, Leg	1
4	14595-1	(000000-)	Clevis, Adjustable	1
5	33565	(000000-)	Lug, Adjustment	1
6	33563	(000000-)	Rod, Adjustment	1
7	23788-1	(000000-)	Ring, Retaining	1
8	33523	(000000-)	Spring, Tension	1
9	33763	(000000-)	Shaft, Stop	1
10	23788	(000000-)	Ring, Retaining	1
11	35533	(000000-)	Support, Leg	1
12	35527	(000000-)	Link	1
13	36972	(000000-)	Pin, Grooved	1
14	32282	(000000-)	Bumper, L.H.	1
15	14895	(000000-)	Shim	1
16	82189	(000000-)	Bracket, L	1
17	48951-1	(000000-)	Plate, End	4
18	36663	(000000-)	Sleeve	2
19	32495	(000000-)	Washer	2

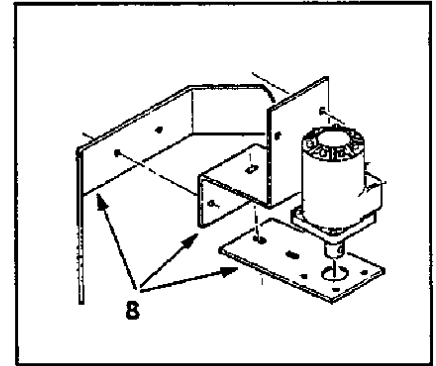
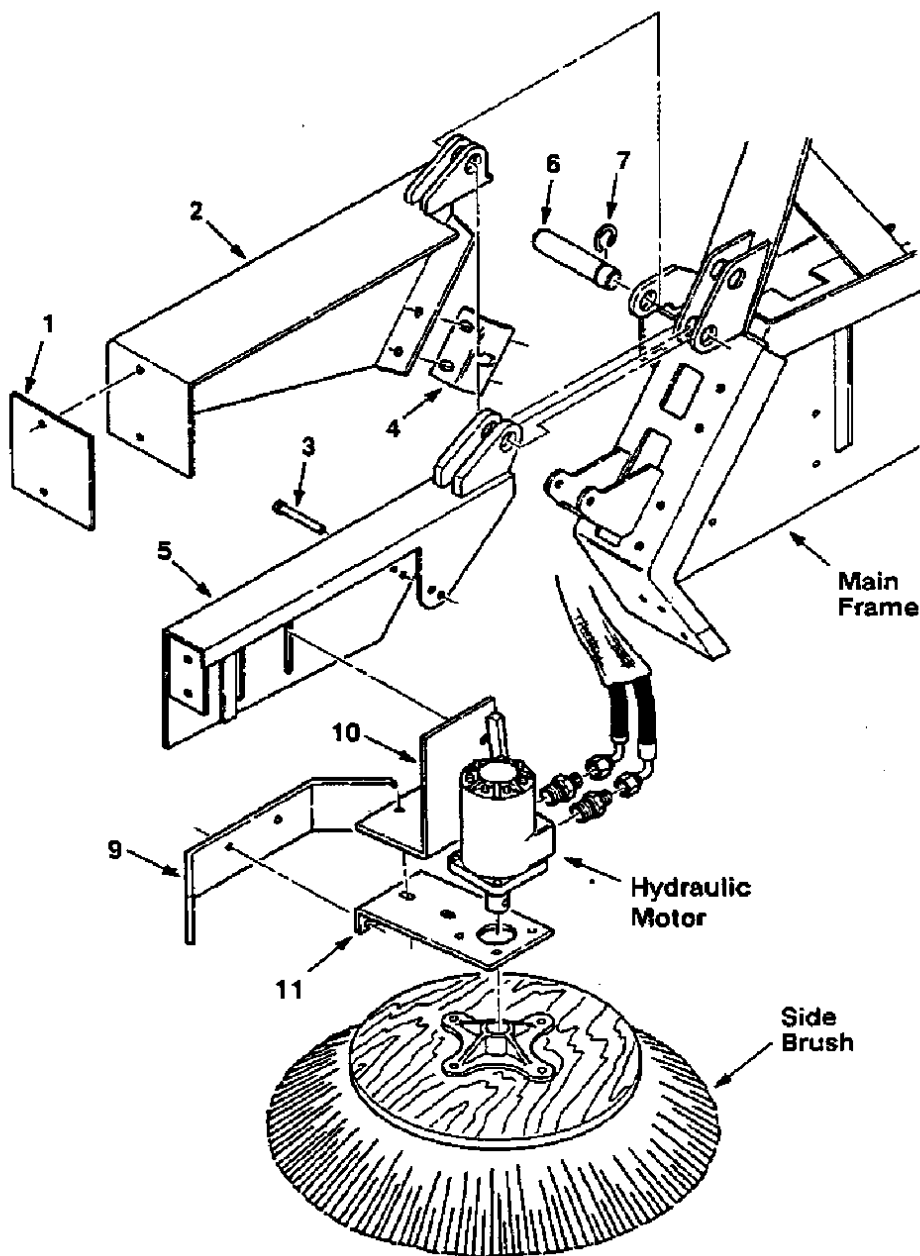

Fig. 8 - Side Brush Group, Multi-Level Dump

02715

Key	Tennant® Part No.	Machine Serial Number	Description	Qty.
1	48951-1	(000000-)	Plate, End	1
2	36958	(000000-)	Bumper, R.H.	1
3	23191	(000000-)	Pin, Clevis	1
4	82189	(000000-)	Bracket, L	1
5	55662	(000000-)	Arm, Brush	1
6	36993	(000000-)	Pin, Grooved	1
7	23788	(000000-)	Ring, Retaining	1
8	33834	(000000-002294)	Replacement Kit, Side Brush Mounting	1
9	82273	(002295-)	Bumper, Side Brush	1
10	02482	(002295-)	Bracket, Bumper	1
11	82272	(002295-)	Plate, Motor Mounting	1

NOTE: To identify parts shown but not listed here, see Section 5, Low Dump Model Parts.

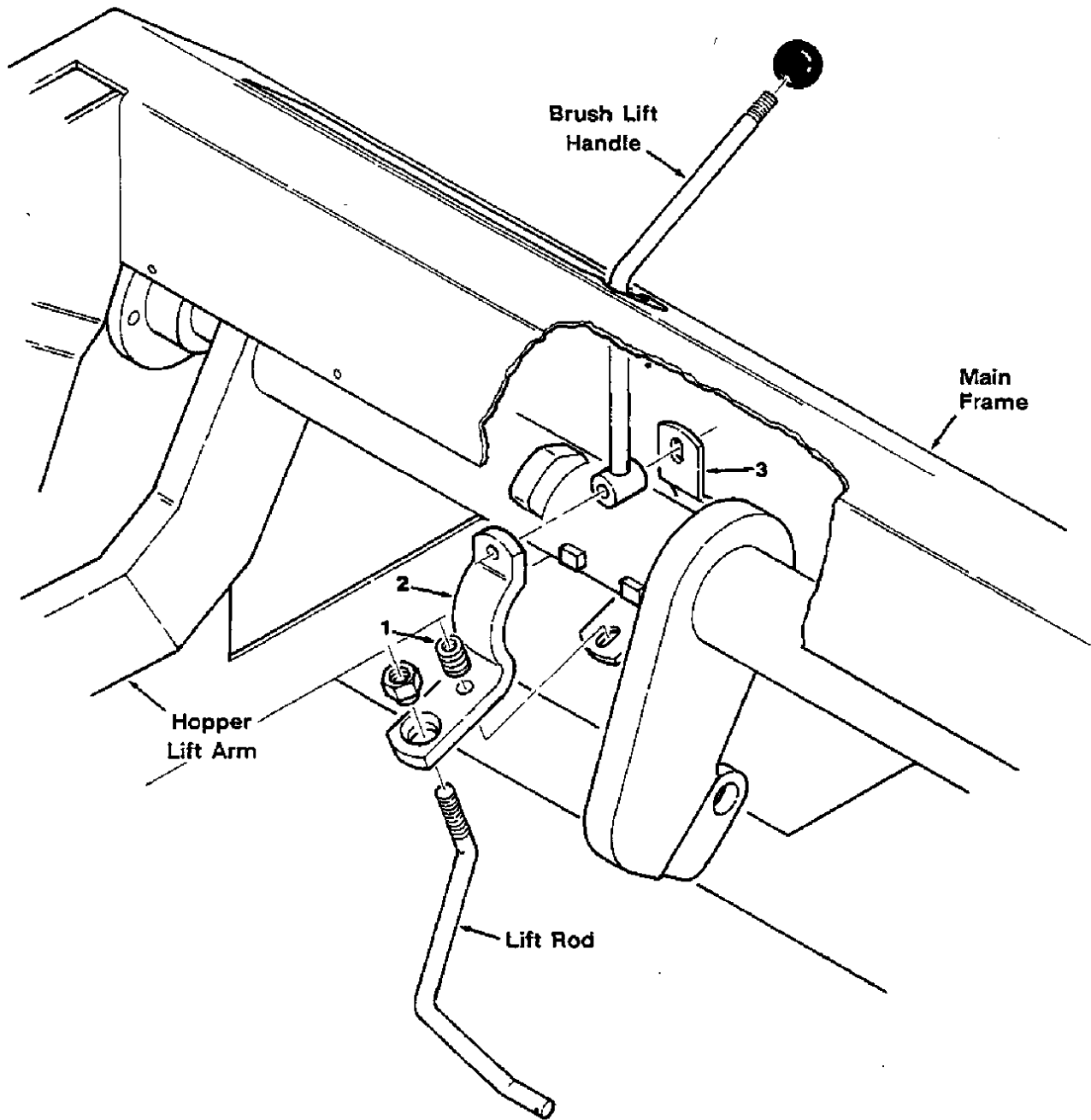

Fig. 9 - Main Brush Lift Group, Multi-Level Dump

02566

Key	Tennant® Part No.	Machine Serial Number	Description	Qty.
1	14174	(000000-)	Spring, Compression	1
2	53907	(000000-)	Lever, Lift Handle	1
3	53899	(000000-)	Clip, Lift Handle	1

NOTE: To identify parts shown but not listed here, see Section 5, Low Dump Model Parts.

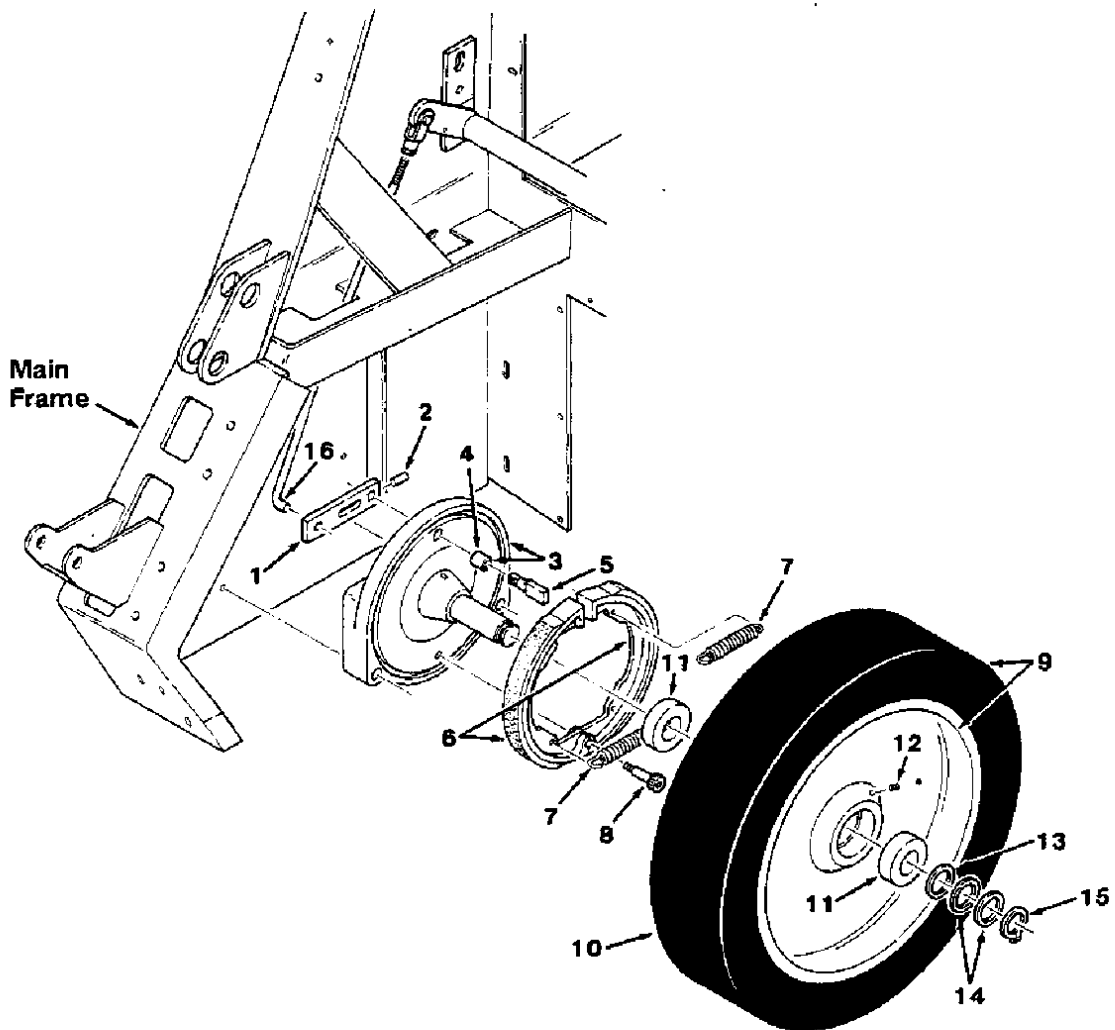

Fig. 10 - Front Wheel and Brakes Group, Multi-Level Dump

04183

Key	Tennant® Part No.	Machine Serial Number	Description	Qty.
	82232	(000000-)	Axle Assembly, Front	2
1	23484	(000000-)	Arm	1
2	20021	(000000-)	Pin, Roll	1
3	08108	(000000-003129)	Replacement Kit, Front Axle	1
3	08107	(003130-)	Axle, Front	1
4	24992	(000000-)	Bushing, Sleeve	1
5	23272	(000000-)	Cam	1
6	56058	(000000-)	Brake Assembly	2
7	09758	(000000-)	Spring, Tension	2
8	56060	(000000-)	Screw, Shoulder	1
	82230	(000000-)	Wheel Assembly, Front	2
9	82238	(000000-)	Wheel and Tire Assembly	1
10	25197A	(000000-)	Tire	1
11	33816	(000000-)	Bearing, Ball	2
12	10552	(000000-)	Plug	1
13	82226	(000000-)	Washer	2
14	82227	(000000-)	Washer	4
15	06442	(000000-)	Ring, Retaining	2
16	82219	(000000-)	Rod, Control	2

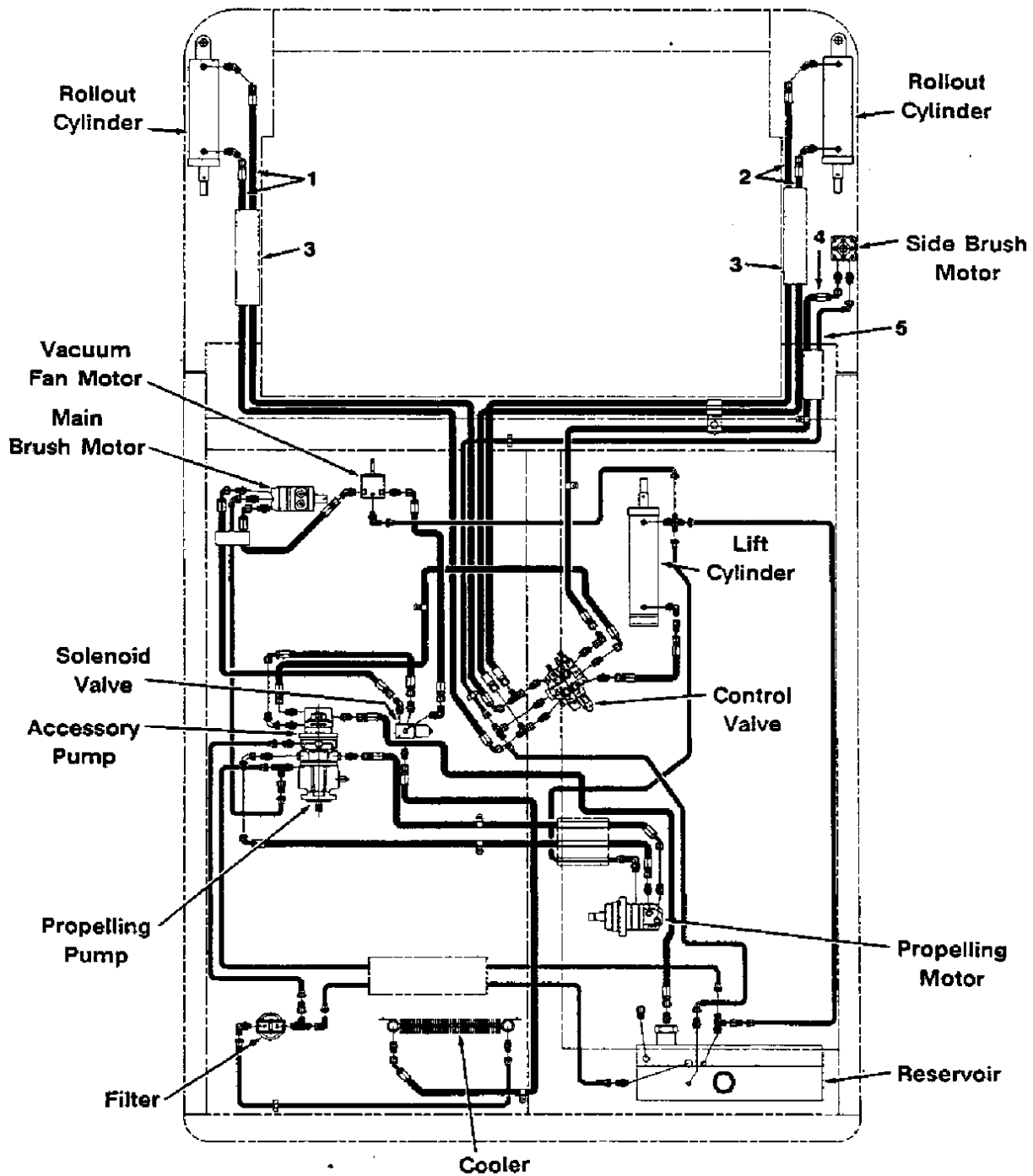

Fig. 11 - Hydraulic Hoses Group, Multi-Level Dump

02583

Key	Tennant® Part No.	Machine Serial Number	Description	Qty.
1	82817	(000000-)	Hose, Hydraulic	2
2	82815	(000000-)	Hose, Hydraulic	2
3	82834	(000000-)	Sleeve, Hose	2
4	82816	(000000-)	Hose, Hydraulic	1
5	82808	(000000-)	Hose, Hydraulic	1

NOTE: To identify parts shown but not listed here, see Section 5, Low Dump Model Parts.

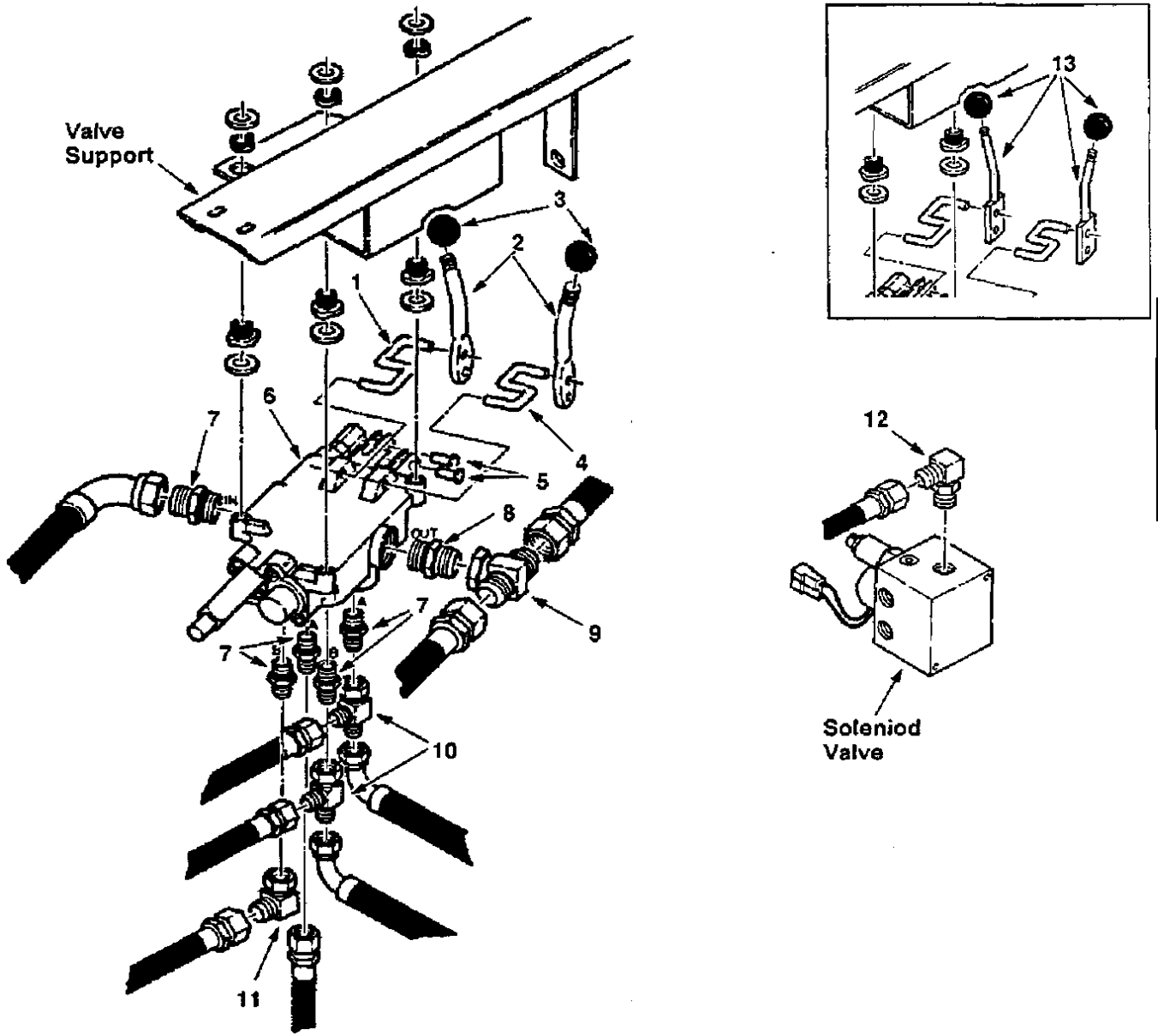

Fig. 12 - Hydraulic Control Valve Group, Multi-Level Dump

04503

Key	Tennant® Part No.	Machine Serial Number	Description	Qty.
1	82762	(000000-)	Link, Hook	1
2	02687	(003438-)	Handle, Valve	2
3	26156	(003438-)	Knob	2
4	32759	(000000-)	Link, Hook	1
5	14605	(000000-)	Pin, Clevis	2
6	34319	(000000-)	Valve, Hydraulic	1
7	55686	(000000-)	Fitting, Straight	5
8	52402	(000000-)	Fitting, Straight	1
9	35586	(000000-)	Fitting, Tee	1
10	57988	(000000-)	Fitting, Tee	2
11	39210	(000000-)	Fitting, Elbow	1
12	44868	(000000-)	Fitting, Elbow	1
13	02688	(000000-003437)	Replacement Kit, Handle	2

NOTE: To identify parts shown but not listed here, see Section 5, Low Dump Model Parts.

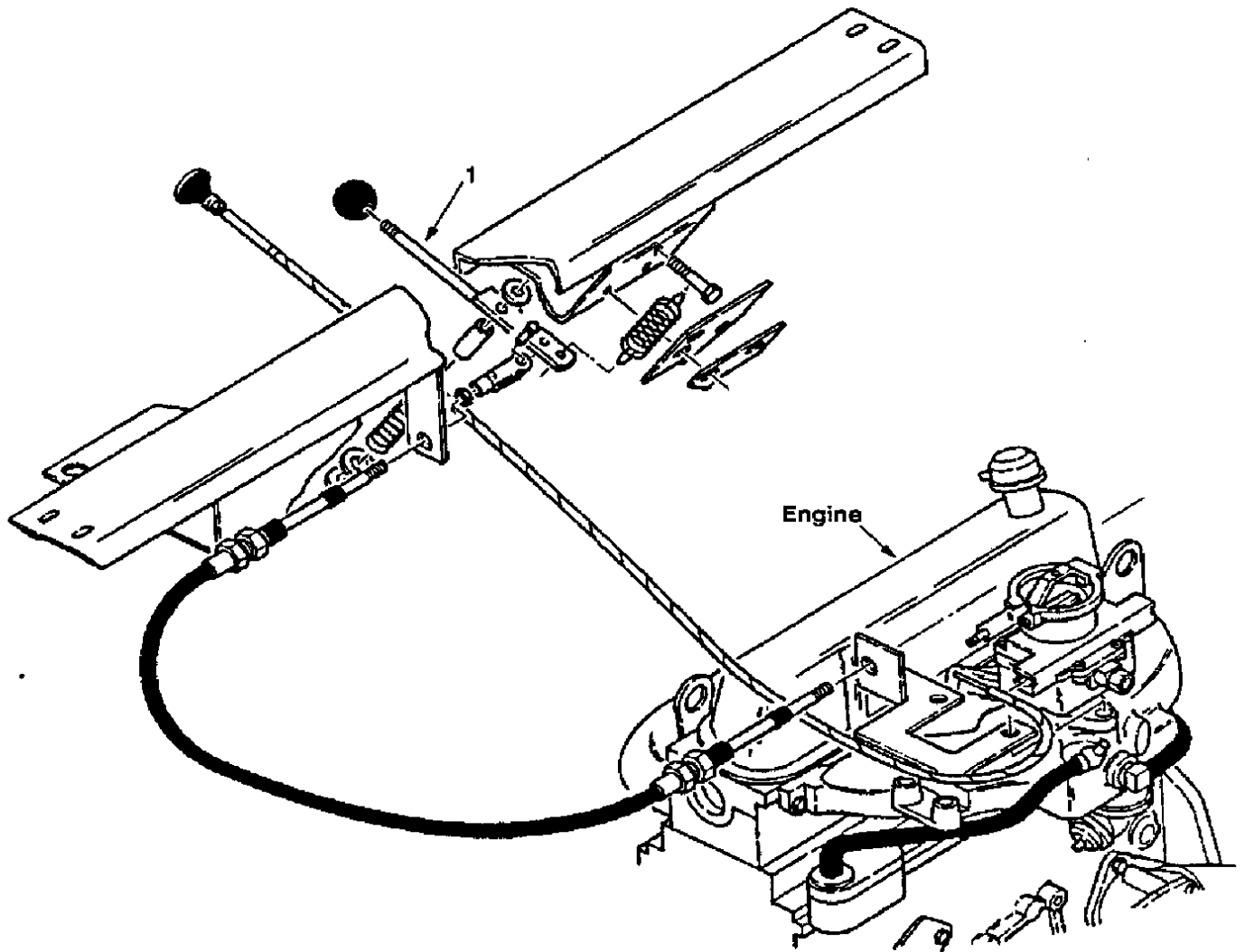

Fig. 13 - Throttle Linkage Group Multi-Level Dump

04614

Key	Tennant® Part No.	Machine Serial Number	Description	Qty.
1	82941	(000000-)	Handle	1

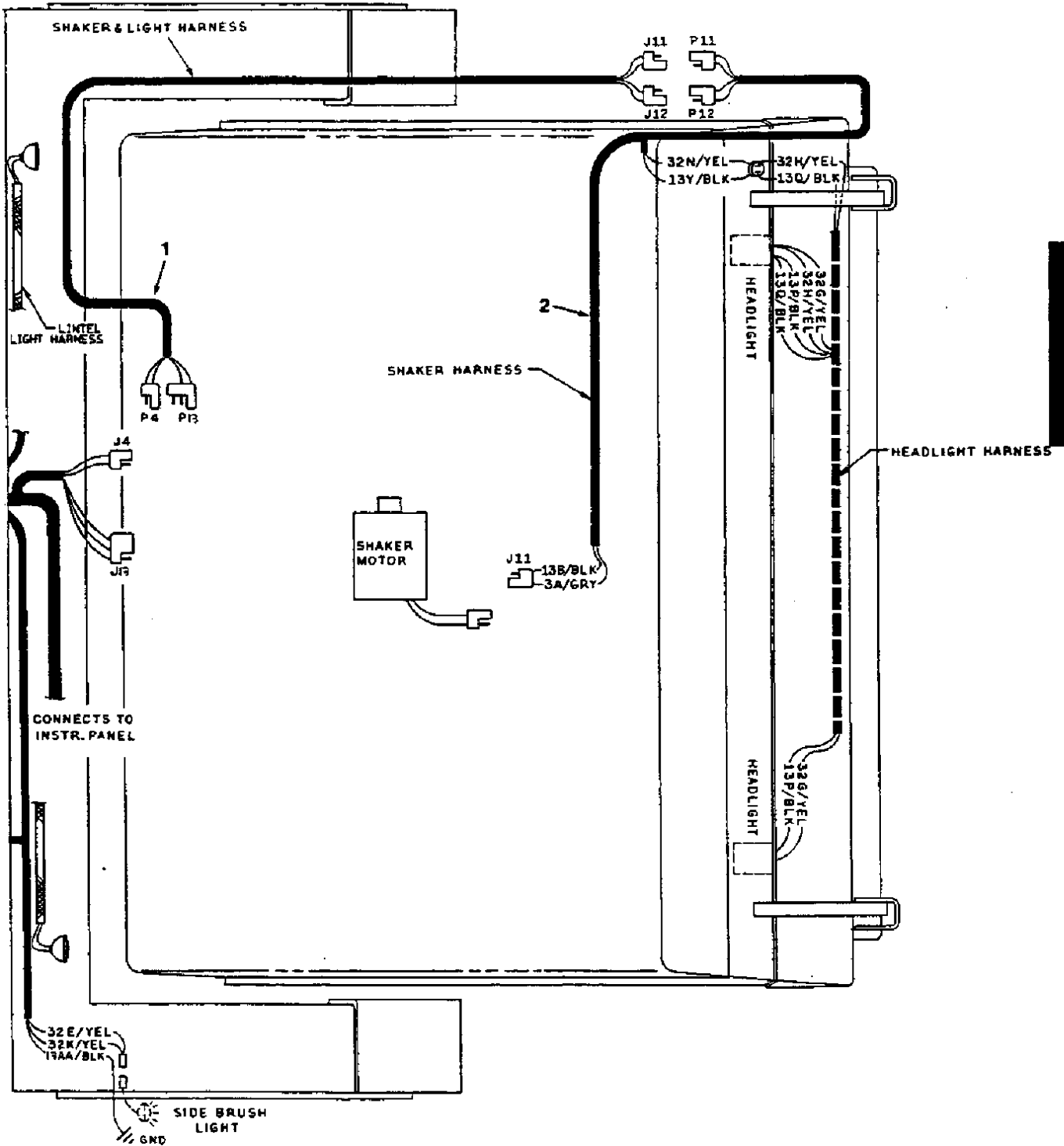

Fig. 14 - Wire Harnesses Group, Multi-Level Dump

02549

Key	Tennant® Part No.	Machine Serial Number	Description	Qty.
1	82704	(000000-)	Wire Harness, Shaker	1
2	82724	(000000-)	Wire Harness, Hopper	1

Home	Find...	Go To..		
------	---------	---------	---	---

SECTION 9

SE LOW DUMP MODEL PARTS

CONTENTS

	Page
Ordering Repair Parts	9-1
Fig. 1 - Main Frame Group, SE	9-2
Fig. 2 - Alternator and Radiator Group, SE	9-3
Fig. 3 - Fuel Tank Group, SE	9-4
Fig. 4 - Instrument Panels Group, SE	9-5
Fig. 5 - Pressure Switch Group, SE	9-6
Fig. 6 - Overhead Guard Group, SE	9-7
Fig. 7 - Rear Wheel Assembly, SE	9-8
Fig. 8 - Battery Group, SE	9-9
Fig. 9 - Air Cleaner Group, SE	9-10
Fig. 10 - Suspension Seat Group, SE	9-11
Fig. 11 - Front Wheel and Brakes Group, SE	9-12

NOTE: Section 9, SE Low Dump Model Parts, lists repair parts unique to a gasoline powered, low dump, Model 275SE.

ORDERING REPAIR PARTS

The components used in this machine have been carefully selected for performance and safety. Use only Tennant Company specified or equivalent parts.

To receive prompt service in filling of your parts orders, please direct all orders for parts with Tennant Company part numbers to the Tennant Company, and all orders for parts with vendor part numbers to the local supplier of the respective vendor.

When ordering parts, please furnish all of the following information:

1. Machine model number - shown on the machine data plate.

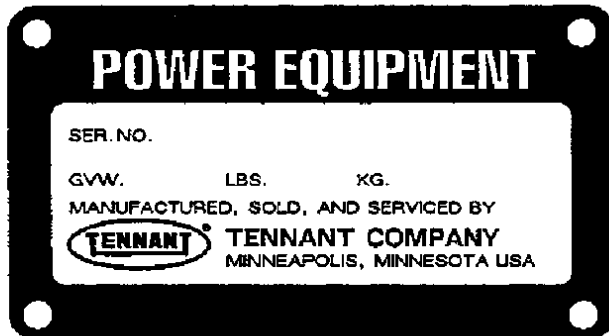

2. Machine serial number - shown on the machine data plate.
3. Engine type - gasoline, LPG, diesel, electric.
4. Company name.
5. Shipping address.
6. Billing address.
7. Name, first and last - of person ordering parts.
8. Telephone number.
9. Purchase order number.
10. Part number, description, and quantity - of each item on the order.

Do not order parts by key number or the figure number of the illustrated parts. Indented items indicate parts of assemblies. Standard hardware is furnished only when part of a purchased assembly. Please get hardware from a local hardware supplier.

If the old part cannot be identified, send it to us with the quantity needed specified on the order.

Any claim for loss or damage to a shipment in transit should be filed promptly against the transportation company making the delivery. Shipments will be complete unless the packing list or order acknowledgement indicate items back ordered.

If parts received are suspected to be incorrect or defective, please write, wire, or phone the Tennant Company representative from whom you ordered the part. They will give authorization for return and/or handle replacement shipments when required.

SERIAL NUMBER INFORMATION EXPLANATION

Serial number listings are shown to indicate on which machines each part can be used. These listings are explained by the following examples:

(000000-) The part can be used on all machines.

(003342-) The part can be used on all machines beginning with the serial number listed.

(000000-004320) The part can be used on all machines up to and including serial number listed.

(004321-005678) The part can be used on all machines between and including the serial numbers listed.

Where xxxxx's are listed in place of a serial number, it indicates a change was made but the exact serial number had not been established when the catalog went to press.

SI UNITS OF MEASURE (INTERNATIONAL SYSTEM)

Metric equivalents have been included, where applicable, throughout this parts catalog.

FASTENER STRENGTH IDENTIFICATION

Fasteners required to have high-strength qualities equivalent to SAE Grade 8 are identified throughout this catalog by the description GR 8. Unless identified by this description, all standard fasteners are SAE Grade 5.

(Specifications and design subject to change without notice.)

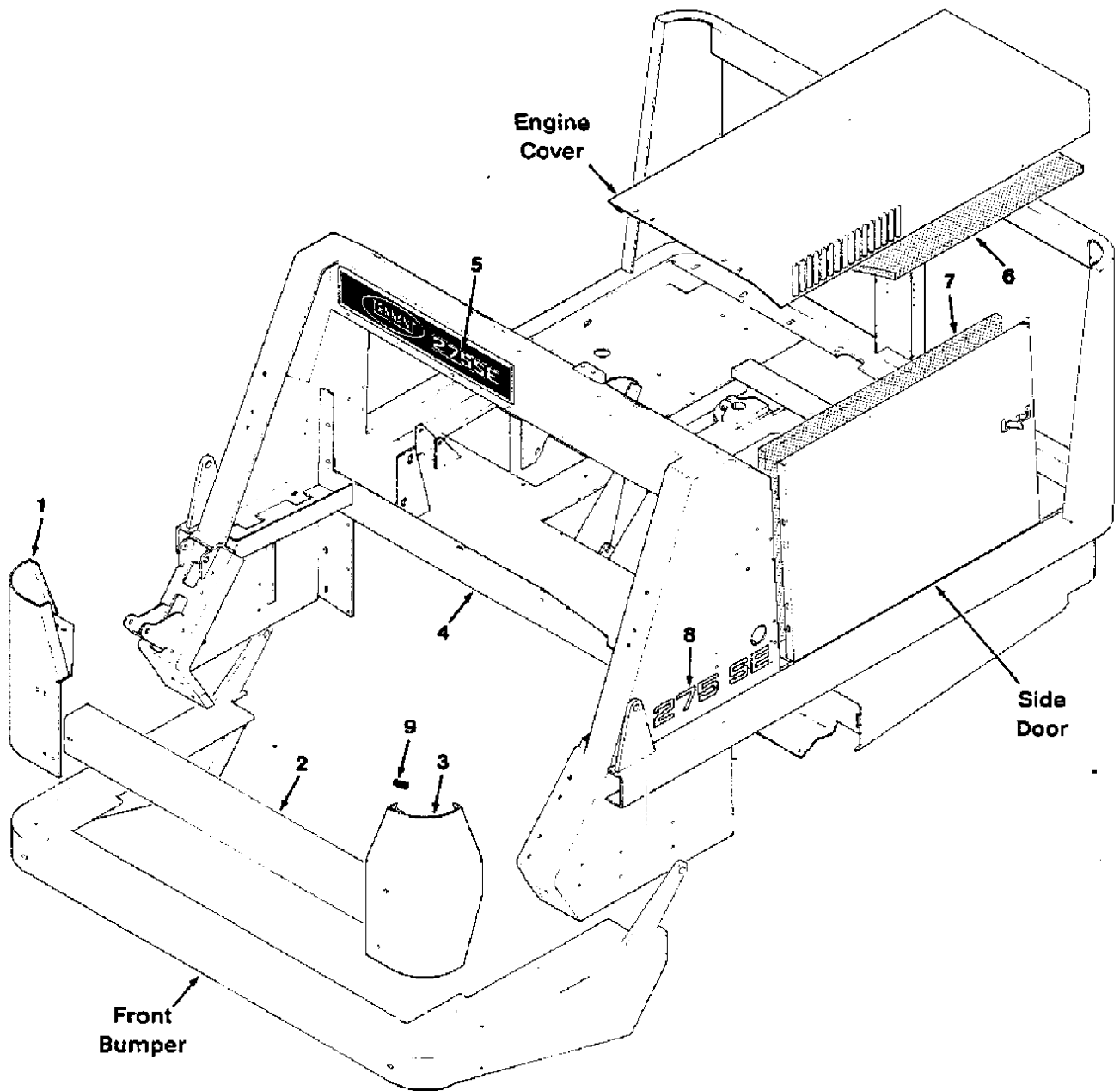

Fig. 1 - Main Frame Group, SE

02712

Key	Tennant® Part No.	Machine Serial Number	Description	Qty.
1	82176	(000000-)	Tower, R.H.	1
2	03023	(000000-)	Channel, Front Bumper	1
3	82171	(000000-)	Tower, L.H.	1
4	82160	(000000-)	Frame, Main	1
5	82720	(000000-)	Plate, Front Logo	1
6	82295	(000000-)	Insulation, Foam	1
7	82294	(000000-)	Insulation, Foam	1
8	82658	(000000-)	Label, 275SE	1
9	02944	(000000-)	Molding, Rigid	1

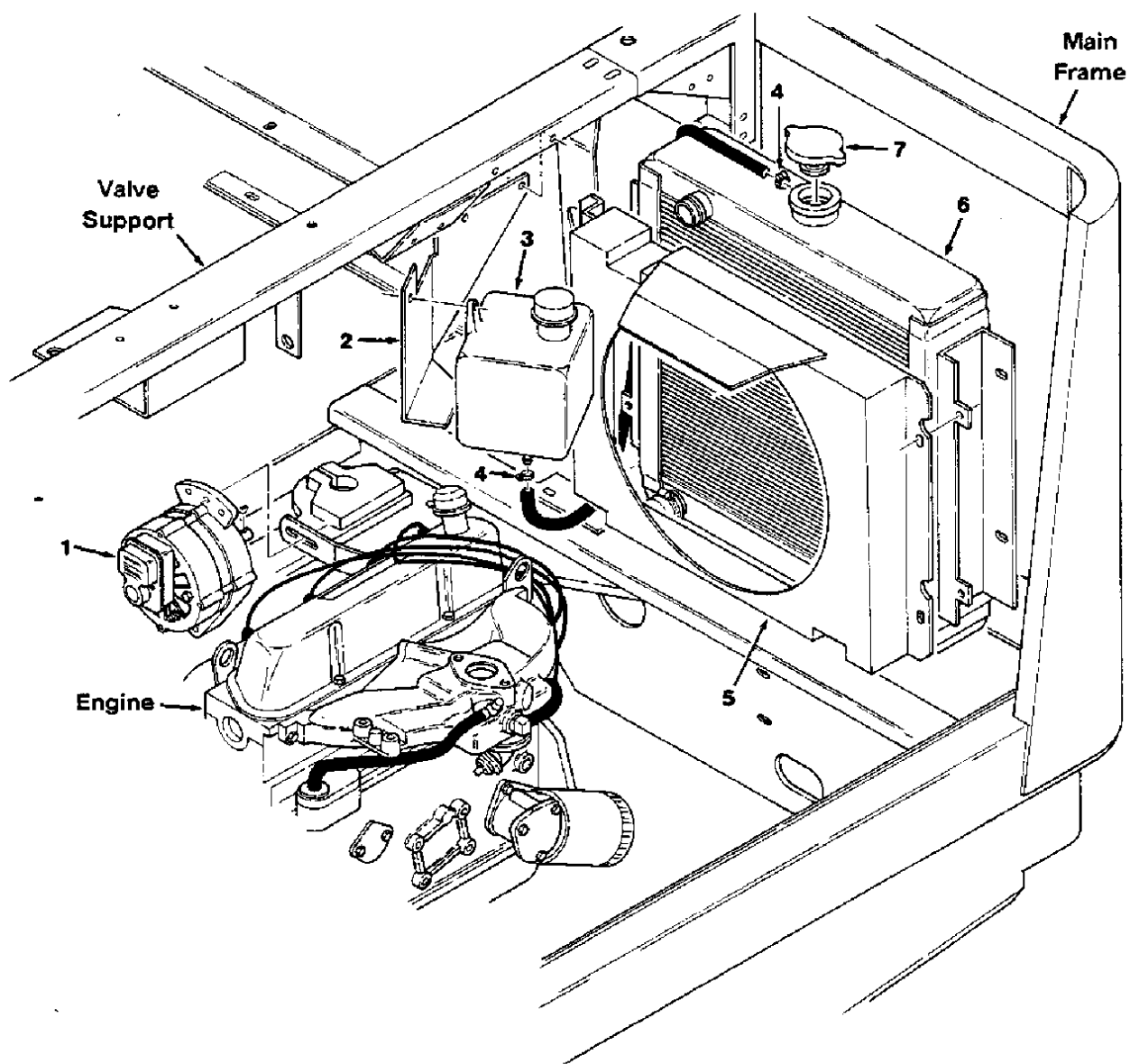

Fig. 2 -- Alternator and Radiator Group, SE

02720

Key	Tennant® Part No.	Machine Serial Number	Description	Qty.
1	82511	(000000-)	Alternator	1
2	82699	(000000-)	Bracket, Tank	1
3	82694	(000000-)	Tank, Coolant Recovery	1
4	43844	(000000-)	Clamp, Worm Drive	2
5	82256	(000000-)	Shroud Assembly, Fan	1
6	82653	(000000-)	Radiator	1
7	82688	(000000-)	Cap, Radiator	1
	51305	(000000-)	Drain Cock, Radiator	1

NOTE: To identify parts shown but not listed here, see Section 5, Low Dump Model Parts.

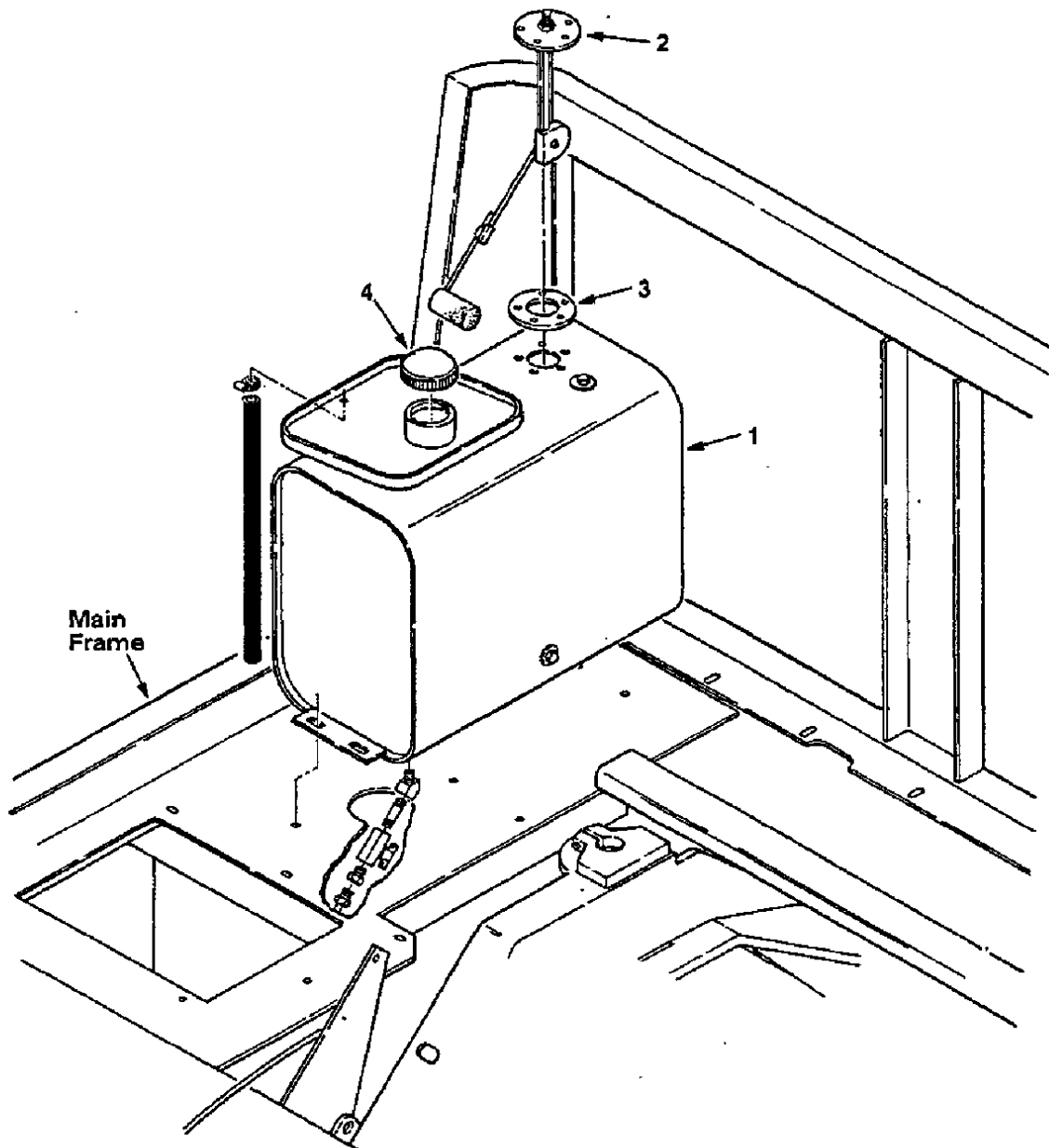

Fig. 3 - Fuel Tank Group, SE

02717

Key	Tennant® Part No.	Machine Serial Number	Description	Qty.
1	82729	(000000-)	Tank, Fuel	1
2	47473	(000000-)	Sending Unit, Tank	1
	68106	(000000-)	Terminal, Tab	1
3	14131	(000000-)	Gasket	1
4	48267	(000000-)	Cap, Tank	1

NOTE: To identify parts shown but not listed here, see Section 5, Low Dump Model Parts.

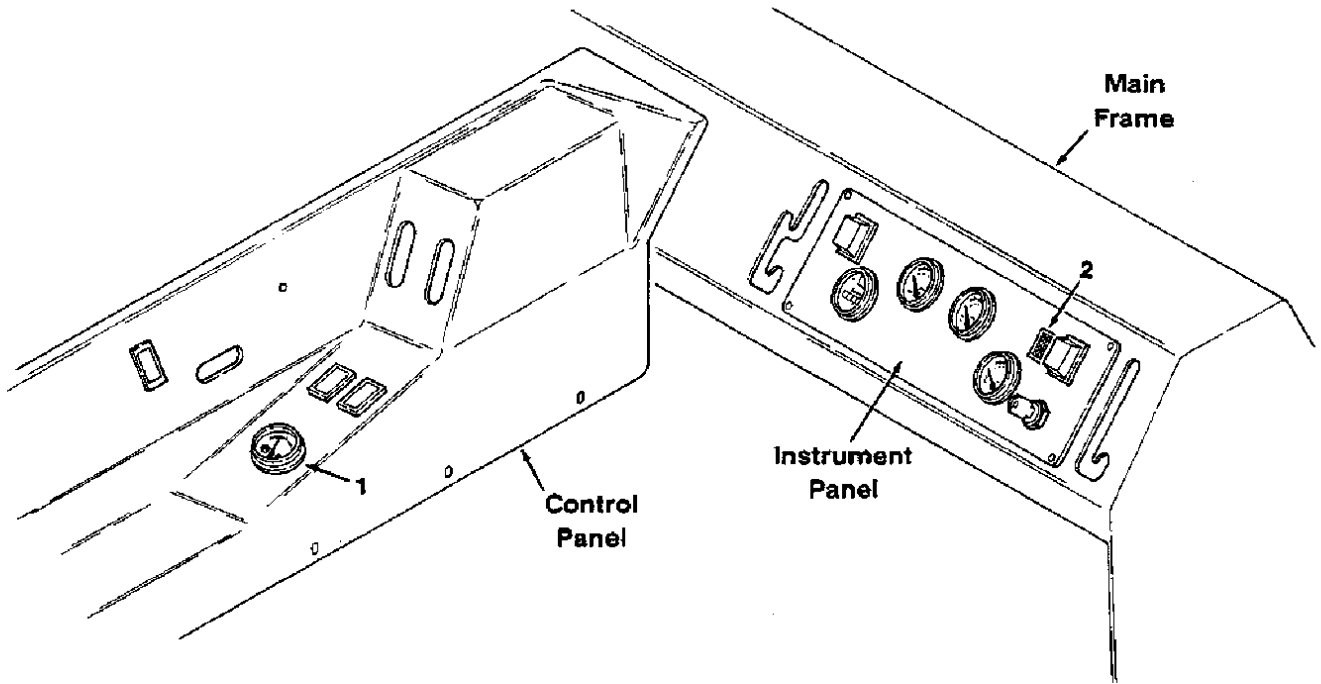

Fig. 4 - Instrument Panels Group, SE

Key	Tennant® Part No.	Machine Serial Number	Description	Qty.
1	34813	(000000-)	Gauge, Fuel	1
2	64141-1	(000000-)	Light Assembly	1

NOTE: To identify parts shown but not listed here, see Section 5, Low Dump Model Parts.

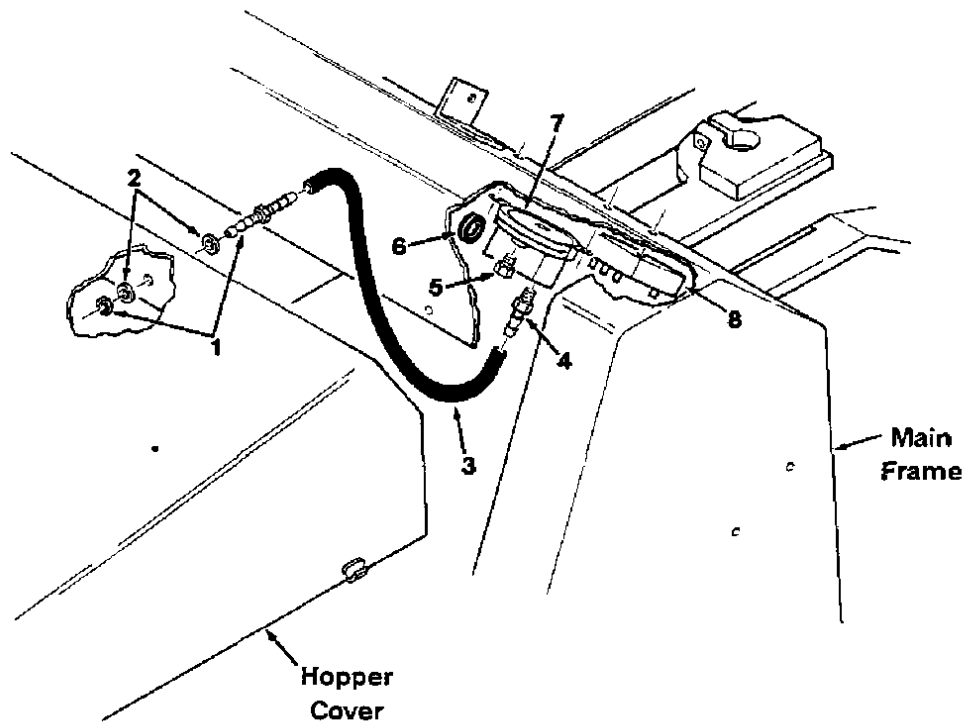

Fig. 5 - Pressure Switch Group, SE

02738

Key	Tennant® Part No.	Machine Serial Number	Description	Qty.
1	39923	(000000-)	Fitting, Bulkhead, Barbed	1
2	43454	(000000-)	Washer, Nylon	2
3	39780-1	(000000-)	Hose, Rubber	1
4	40607	(000000-)	Fitting, Straight	1
5	82739	(000000-)	Fitting, Breather	1
6	10632-4	(000000-)	Grommet	1
7	34868	(000000-)	Switch, Pressure	1
8	34816	(000000-)	Timer, Shaker	1

NOTE: To identify parts shown but not listed here, see Section 5, Low Dump Model Parts.

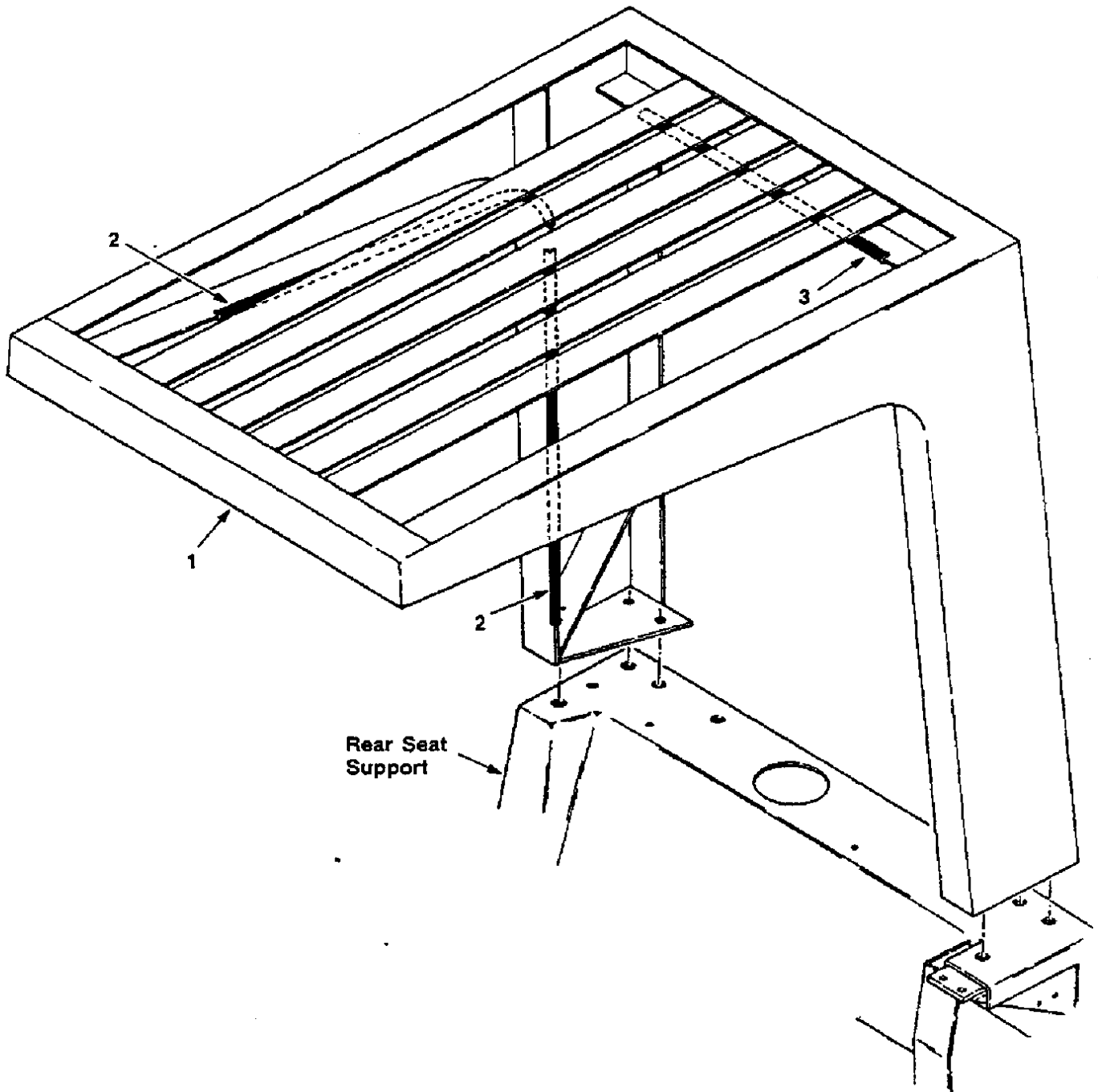

Fig. 6 - Overhead Guard Group, SE

02807

Key	Tennant® Part No.	Machine Serial Number	Description	Qty.
1	55150	(000000-)	Guard, Overhead	1
2	62595-11	(003417-)	Rigid Molding	2
3	62595-2	(003417-)	Rigid Molding	1

NOTE: To identify parts shown but not listed here, see Section 5, Low Dump Model Parts.

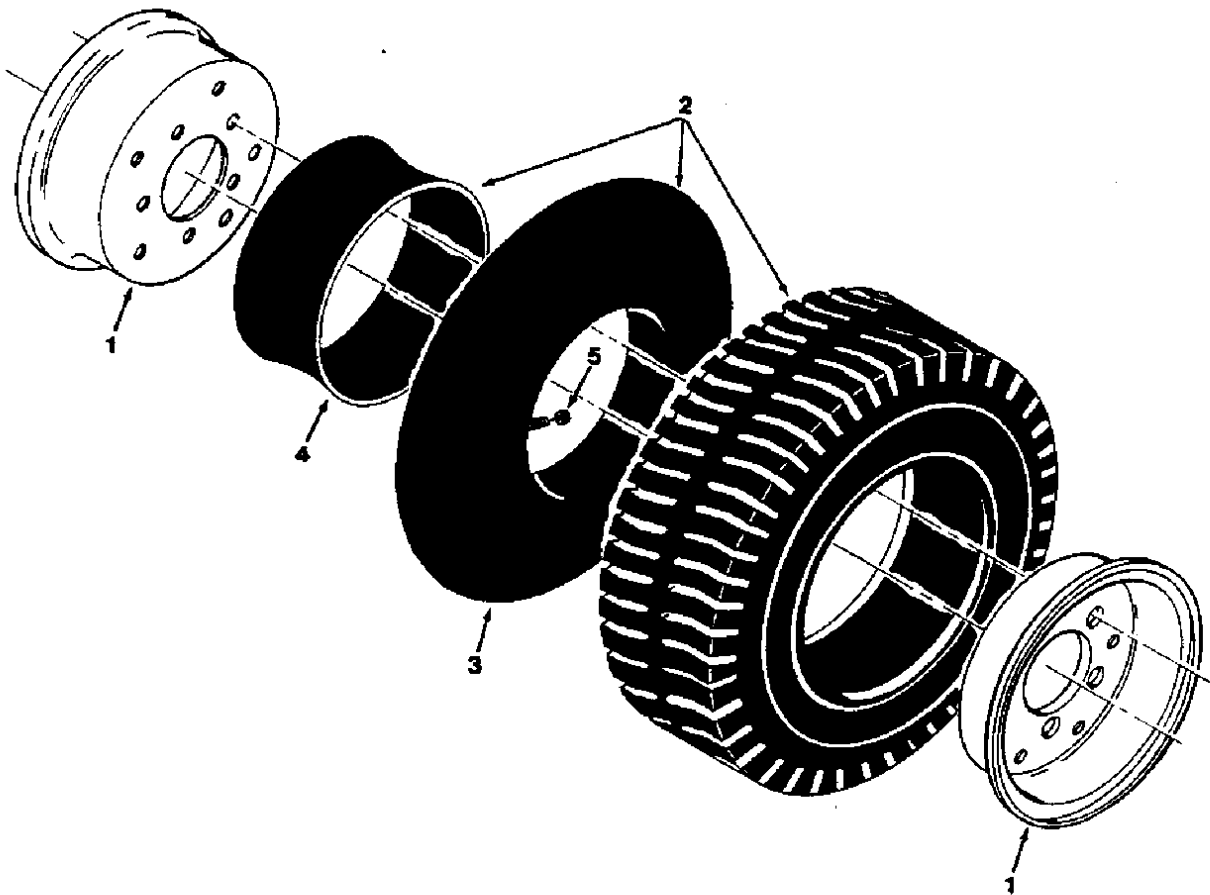

Fig. 7 - Rear Wheel Assembly, SE

02588

Key	Tennant® Part No.	Machine Serial Number	Description	Qty.
	53640	(000000-)	Tire and Wheel Assembly, Steelguard	1
1	53818	(000000-)	Rim Assembly	1
2	53819	(000000-)	Tire, Tube and Flap Assembly	1
3	53819-1	(000000-)	Tube, Inner	1
4	53819-2	(000000-)	Flap, Tube	1
5	45786	(000000-)	Cap, Valve Stem	1

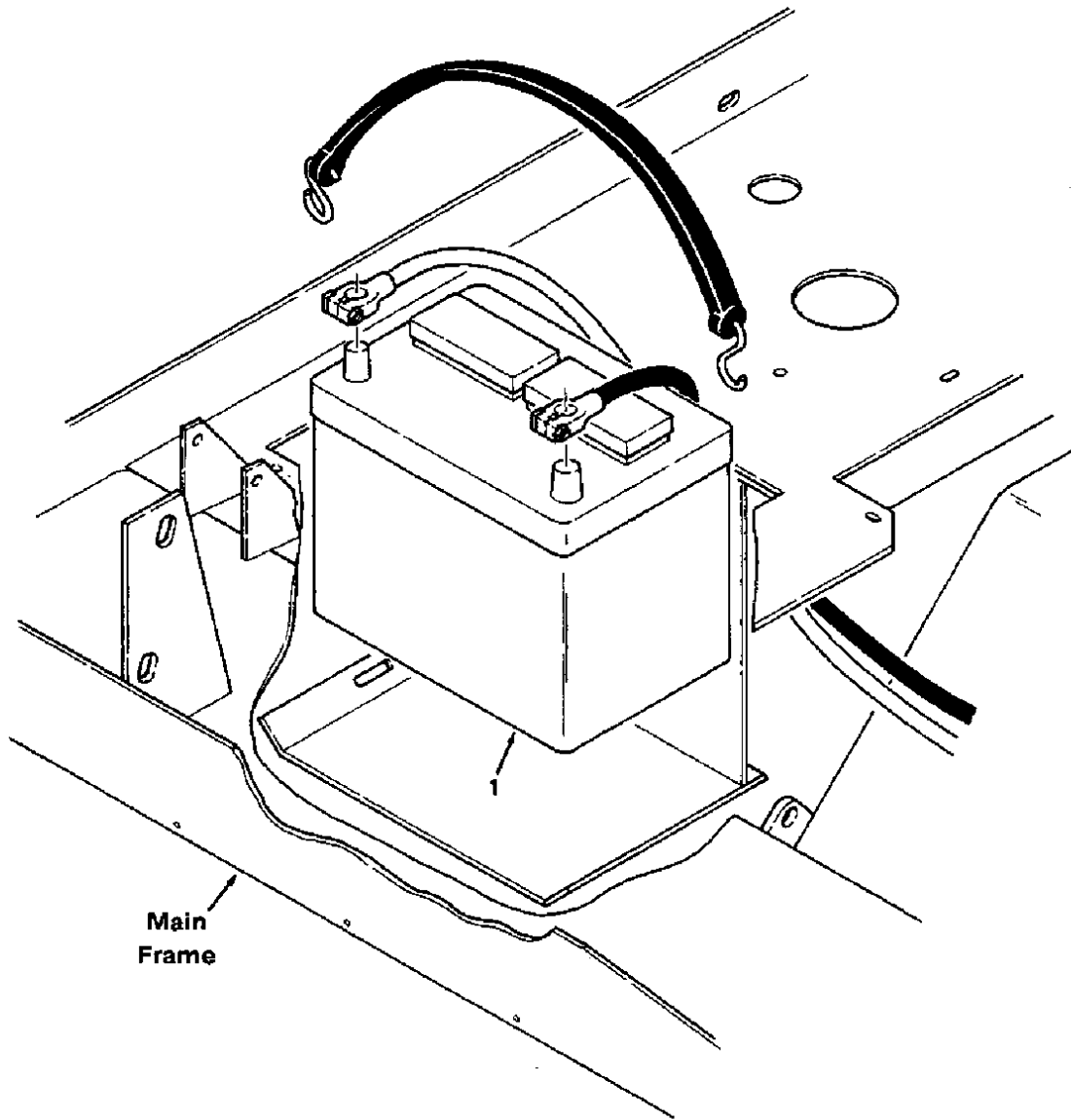

Fig. 8 - Battery Group. SE

Key	Tennant® Part No.	Machine Serial Number	Description	Qty.
1	10143	(000000-)	Battery, 540 CCA	1

02796

NOTE: To identify parts shown but not listed here, see Section 5, Low Dump Model Parts.

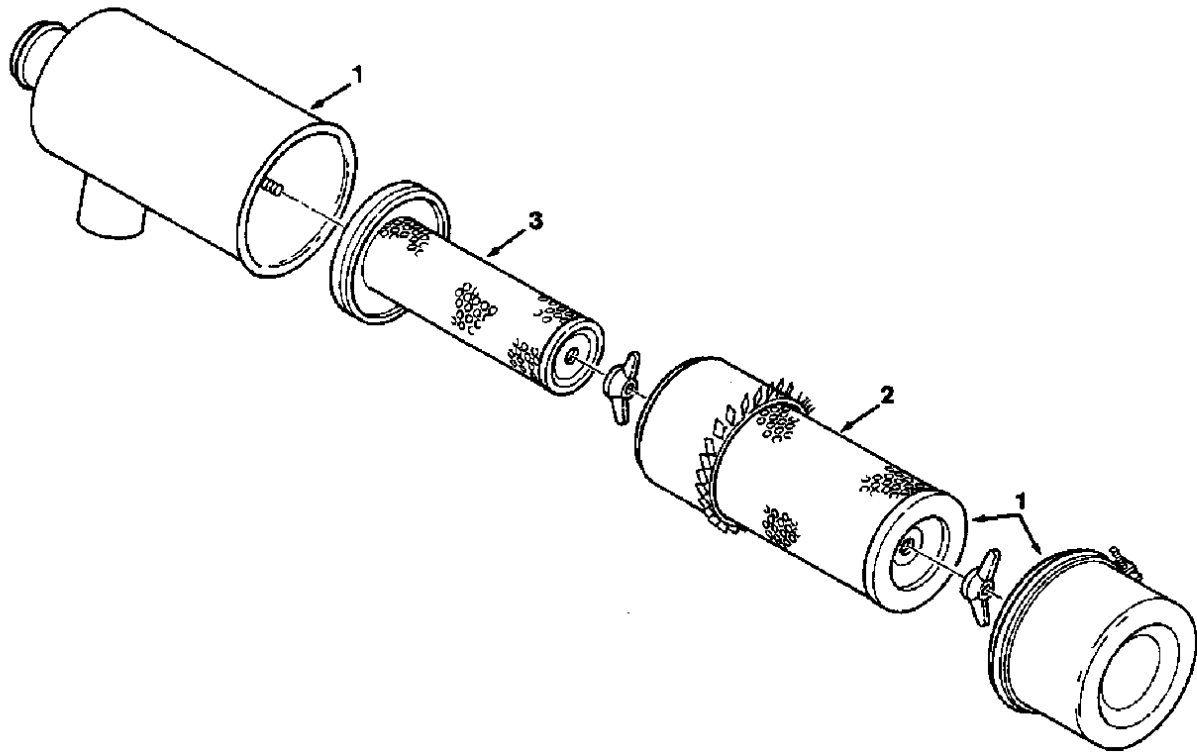

Fig. 9 - Air Cleaner Group, SE

02274

Key	Tennant® Part No.	Machine Serial Number	Description	Qty.
	58539	(000000-)	Air Cleaner, Heavy Duty	1
1	58538	(000000-)	Body, Air Cleaner	1
2	58120	(000000-)	Element, Air Cleaner	1
3	58121	(000000-)	Element, Safety	1

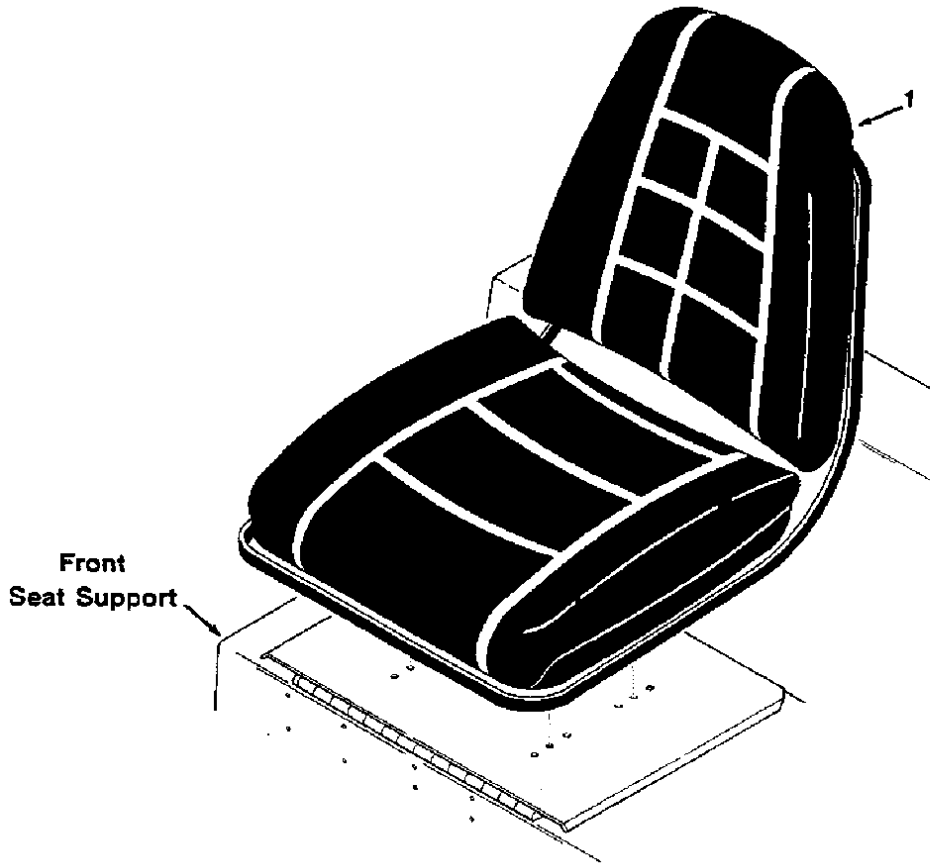

Fig. 10 - Suspension Seat Group, SE

Key	Tennant® Part No.	Machine Serial Number	Description	Qty.
1	82343	(000000-)	Seat, Suspension	1

02809

NOTE: To identify parts shown but not listed here, see Section 5, Low Dump Model Parts.

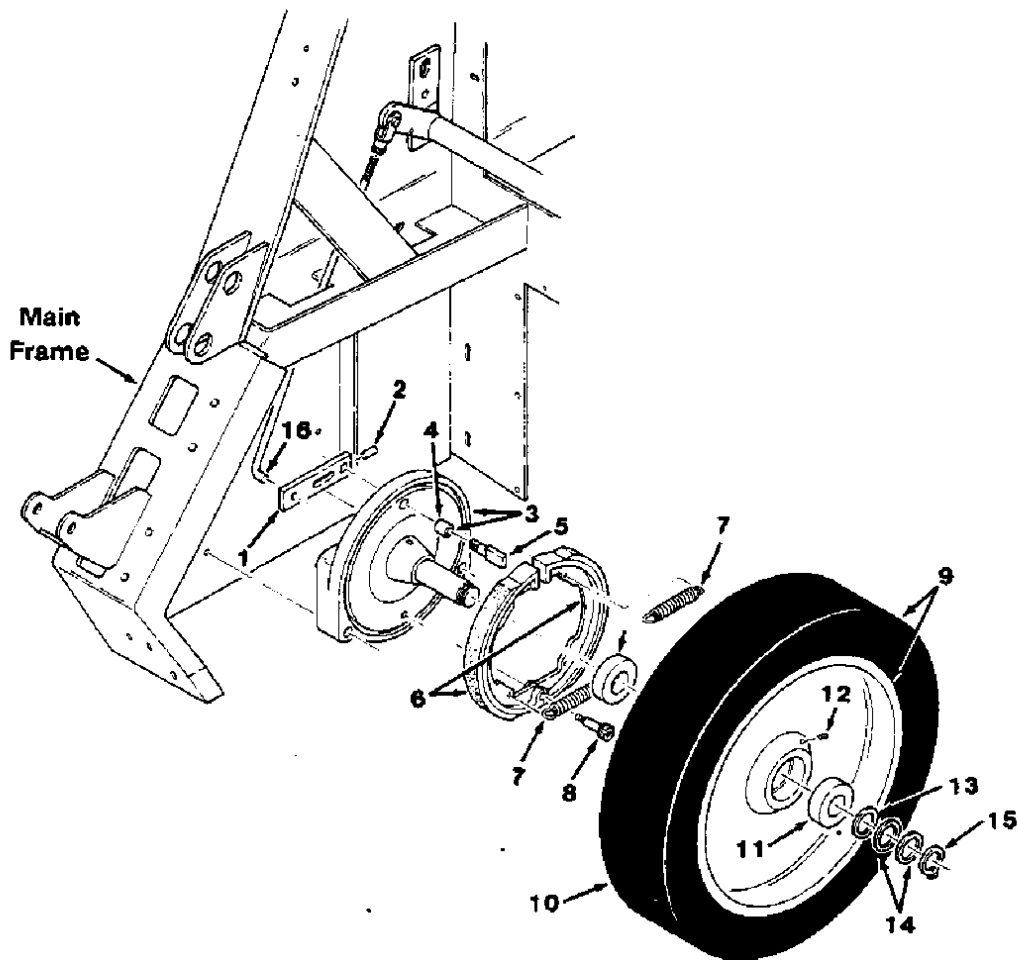

Fig. 11 - Front Wheel and Brakes Group, SE

04184

Key	Tennant® Part No.	Machine Serial Number	Description	Qty.
	82232	(000000-)	Axle Assembly, Front	2
1	23484	(000000-)	Arm	1
2	20021	(000000-)	Pin, Roll	1
3	08108	(000000-003135)	Replacement Kit, Front Axle	1
3	08107	(003136-)	Axle, Front	1
4	24992	(000000-)	Bushing, Sleeve	1
5	23272	(000000-)	Cam	1
6	56058	(000000-)	Brake Assembly	2
7	09758	(000000-)	Spring, Tension	2
8	56060	(000000-)	Screw, Shoulder	1
	82230	(000000-)	Wheel Assembly, Front	2
9	82238	(000000-)	Wheel and Tire Assembly	1
10	25197A	(000000-)	Tire	1
11	33816	(000000-)	Bearing, Ball	2
12	10552	(000000-)	Plug	1
13	82226	(000000-)	Washer	2
14	82227	(000000-)	Washer	4
15	06442	(000000-)	Ring, Retaining	2
16	82219	(000000-)	Rod, Control	2

SECTION 10

SE MULTI-LEVEL DUMP MODEL PARTS

CONTENTS

	Page		Page
Ordering Repair Parts	10-1	Fig. 21 - Air Cleaner Group, SE Multi-Level Dump	10-24
Fig. 1 - Main Frame Group, SE Multi-Level Dump	10-2	Fig. 22 - Suspension Seat Group, SE Multi- Level Dump	10-25
Fig. 2 - Hopper Door Assembly, SE Multi- Level Dump	10-3	Fig. 23 - Throttle Linkage Group, SE Multi- Level Dump	10-26
Fig. 3 - Hopper Group, SE Multi-Level Dump	10-4		
Fig. 4 - Hopper Lift Arms Group, SE Multi- Level Dump	10-6		
Fig. 5 - Hopper Cover and Filter Carrier Group, SE Multi-Level Dump ...	10-8		
Fig. 6 - Hydraulic Lift Cylinder Group, SE Multi-Level Dump	10-9		
Fig. 7 - Stabilizer Leg Group, SE Multi- Level Dump	10-10		
Fig. 8 - Side Brush Group, SE Multi-Level Dump	10-11		
Fig. 9 - Main Brush Lift Group, SE Multi- Level Dump	10-12		
Fig. 10 - Front Wheel and Brakes Group, SE Multi-Level Dump	10-13		
Fig. 11 - Hydraulic Hoses Group, SE Multi- Level Dump	10-14		
Fig. 12 - Hydraulic Control Valve Group, SE Multi-Level Dump	10-15		
Fig. 13 - Wire Harnesses Group, SE Multi- Level Dump	10-16		
Fig. 14 - Alternator and Radiator Group, SE Multi-Level Dump	10-17		
Fig. 15 - Fuel Tank Group, SE Multi-Level Dump	10-18		
Fig. 16 - Instrument Panels Group, SE Multi-Level Dump	10-19		
Fig. 17 - Pressure Switch Group, SE Multi- Level Dump	10-20		
Fig. 18 - Overhead Guard Group, SE Multi- Level Dump	10-21		
Fig. 19 - Rear Wheel Assembly, SE Multi- Level Dump	10-22		
Fig. 20 - Battery Group, SE Multi-Level Dump	10-23		

NOTE: Section 10, SE Multi-Level Dump Model Parts, lists repair parts unique to a gasoline powered, multi-level dump, Model 275SE.

ORDERING REPAIR PARTS

The components used in this machine have been carefully selected for performance and safety. Use only Tennant Company specified or equivalent parts.

To receive prompt service in filling of your parts orders, please direct all orders for parts with Tennant Company part numbers to the Tennant Company, and all orders for parts with vendor part numbers to the local supplier of the respective vendor.

When ordering parts, please furnish all of the following information:

1. Machine model number - shown on the machine data plate.

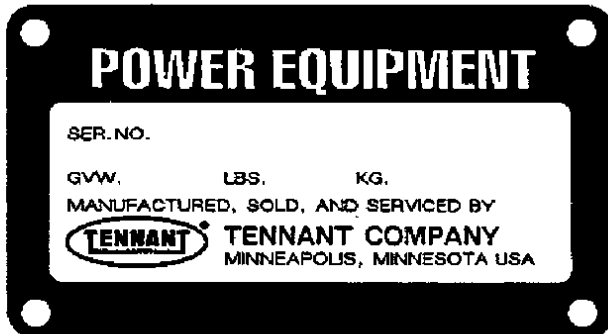

2. Machine serial number - shown on the machine data plate.
3. Engine type - gasoline, LPG, diesel, electric.
4. Company name.
5. Shipping address.
6. Billing address.
7. Name, first and last - of person ordering parts.
8. Telephone number.
9. Purchase order number.
10. Part number, description, and quantity - of each item on the order.

Do not order parts by key number or the figure number of the illustrated parts. Indented items indicate parts of assemblies. Standard hardware is furnished only when part of a purchased assembly. Please get hardware from a local hardware supplier.

If the old part cannot be identified, send it to us with the quantity needed specified on the order.

Any claim for loss or damage to a shipment in transit should be filed promptly against the transportation company making the delivery. Shipments will be complete unless the packing list or order acknowledgement indicate items back ordered.

If parts received are suspected to be incorrect or defective, please write, wire, or phone the Tennant Company representative from whom you ordered the part. They will give authorization for return and/or handle replacement shipments when required.

SERIAL NUMBER INFORMATION EXPLANATION

Serial number listings are shown to indicate on which machines each part can be used. These listings are explained by the following examples:

(000000-) The part can be used on all machines.

(003342-) The part can be used on all machines beginning with the serial number listed.

(000000-004320) The part can be used on all machines up to and including serial number listed.

(004321-005678) The part can be used on all machines between and including the serial numbers listed.

Where xxxxx's are listed in place of a serial number, it indicates a change was made but the exact serial number had not been established when the catalog went to press.

SI UNITS OF MEASURE (INTERNATIONAL SYSTEM)

Metric equivalents have been included, where applicable, throughout this parts catalog.

FASTENER STRENGTH IDENTIFICATION

Fasteners required to have high-strength qualities equivalent to SAE Grade 8 are identified throughout this catalog by the description GR 8. Unless identified by this description, all standard fasteners are SAE Grade 5.

(Specifications and design subject to change without notice.)

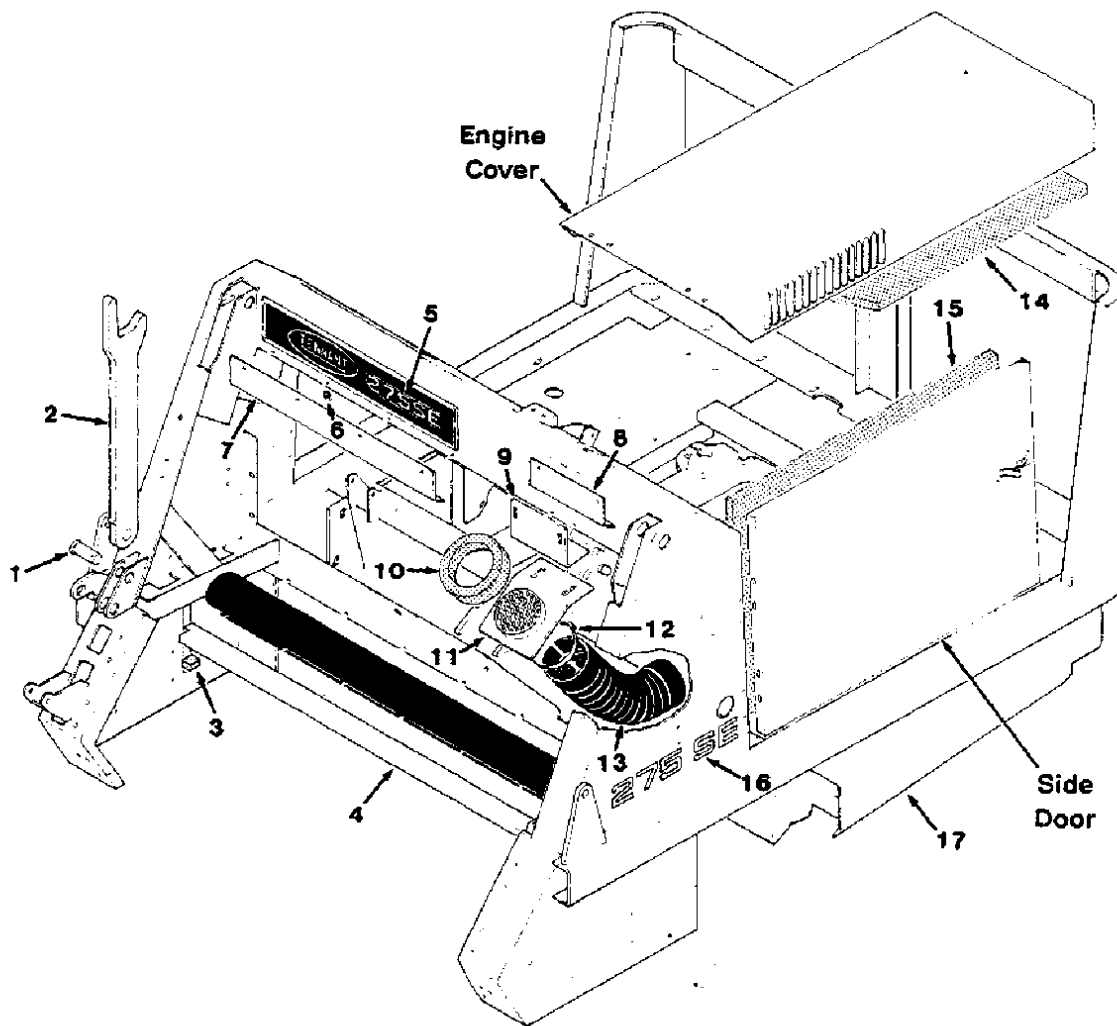

Fig. 1 - Main Frame Group, SE Multi-Level Dump

02713

Key	Tennant® Part No.	Machine Serial Number	Description	Qty.
1	36994	(000000-)	Pin, Clevis	1
2	82193	(000000-)	Arm Assembly, Safety	1
3	54338-6	(000000-)	Seal, Foam Rubber	2
4	50446	(000000-)	Retainer, Top Seal	1
5	82720	(000000-)	Plate, Front Logo	1
6	82138	(000000-)	Nut, Retainer	6
7	82777	(000000-)	Shield, Spray	1
8	82776	(000000-)	Shield, Spray	1
9	82394	(000000-)	Angle, Hose Adjust	1
10	82425	(000000-)	Seal, Fan Inlet	1
11	82393	(000000-)	Connection, Hose	1
12	23498	(000000-)	Clamp, Worm Drive	1
13	51768A	(000000-)	Hose	1
14	82295	(000000-)	Insulation, Foam	1
15	82294	(000000-)	Insulation, Foam	1
16	82658	(000000-)	Label, 275SE	1
17	82170	(000000-)	Frame, Main	1

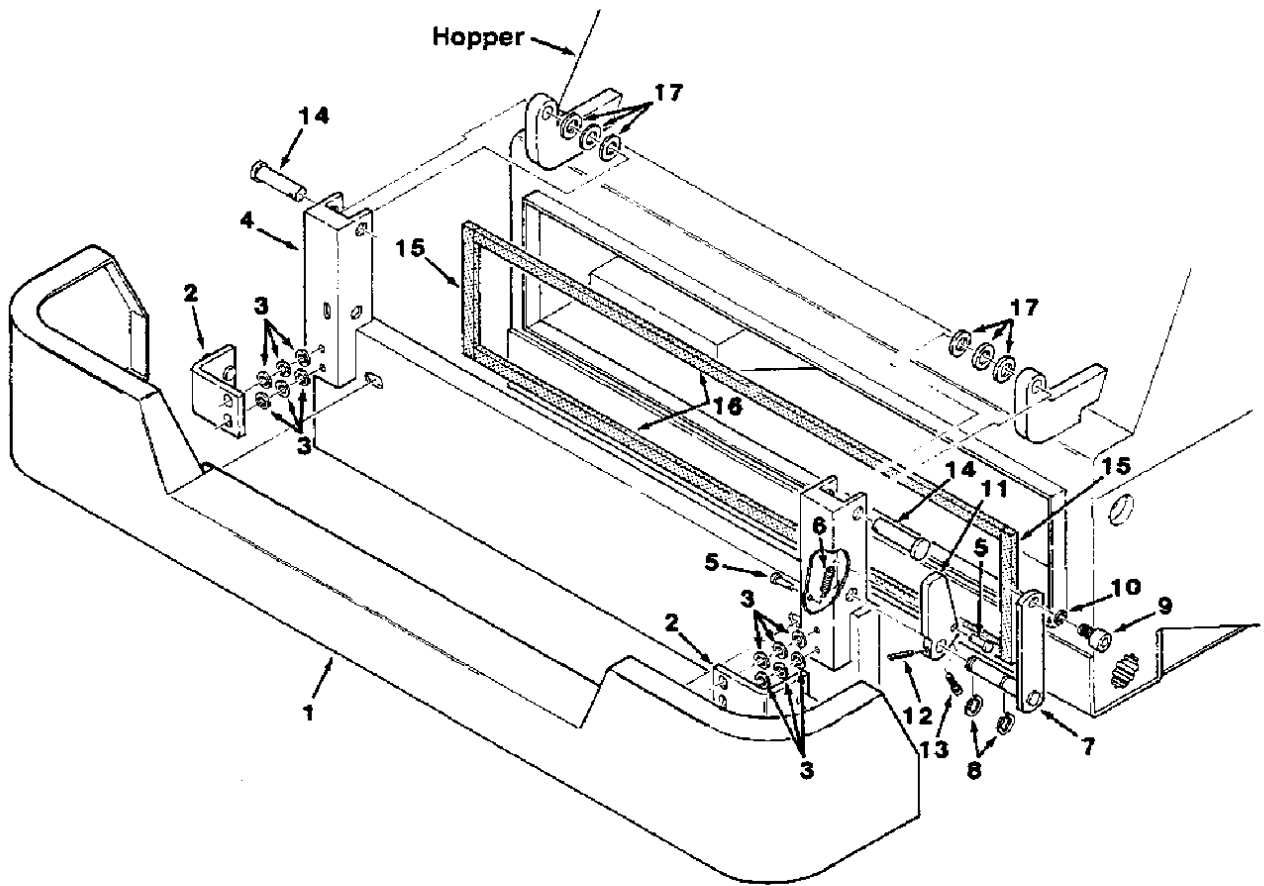

Fig. 2 - Hopper Door Assembly, SE Multi-Level Dump

02705

Key	Tennant® Part No.	Machine Serial Number	Description	Qty.
1	82496	(000000-)	Bumper	1
2	36984	(000000-)	Bracket, Door Latch	2
3	32492	(000000-)	Washer	12
	35669	(000000-)	Door Assembly, Hopper	1
4	35526	(000000-)	Door, Hopper	1
5	82168	(000000-)	Pin, Clevis	2
6	28387	(000000-)	Spring, Tension	1
7	37073	(000000-)	Shaft, Pivot	1
8	23788-1	(000000-)	Ring, Retaining	2
9	48930	(000000-)	Cam, Follower	1
10	35546	(000000-)	Sleeve	1
11	37074	(000000-)	Brace, Hopper Door	1
12	46585	(000000-)	Pin, Roll	1
13	01681	(000000-)	Screw, Socket	1
14	04733-3	(000000-)	Pin, Clevis	2
15	37055	(000000-)	Seal, Foam Rubber	2
16	37054	(000000-)	Seal, Foam Rubber	2
17	35540	(000000-)	Shim, Washer	6

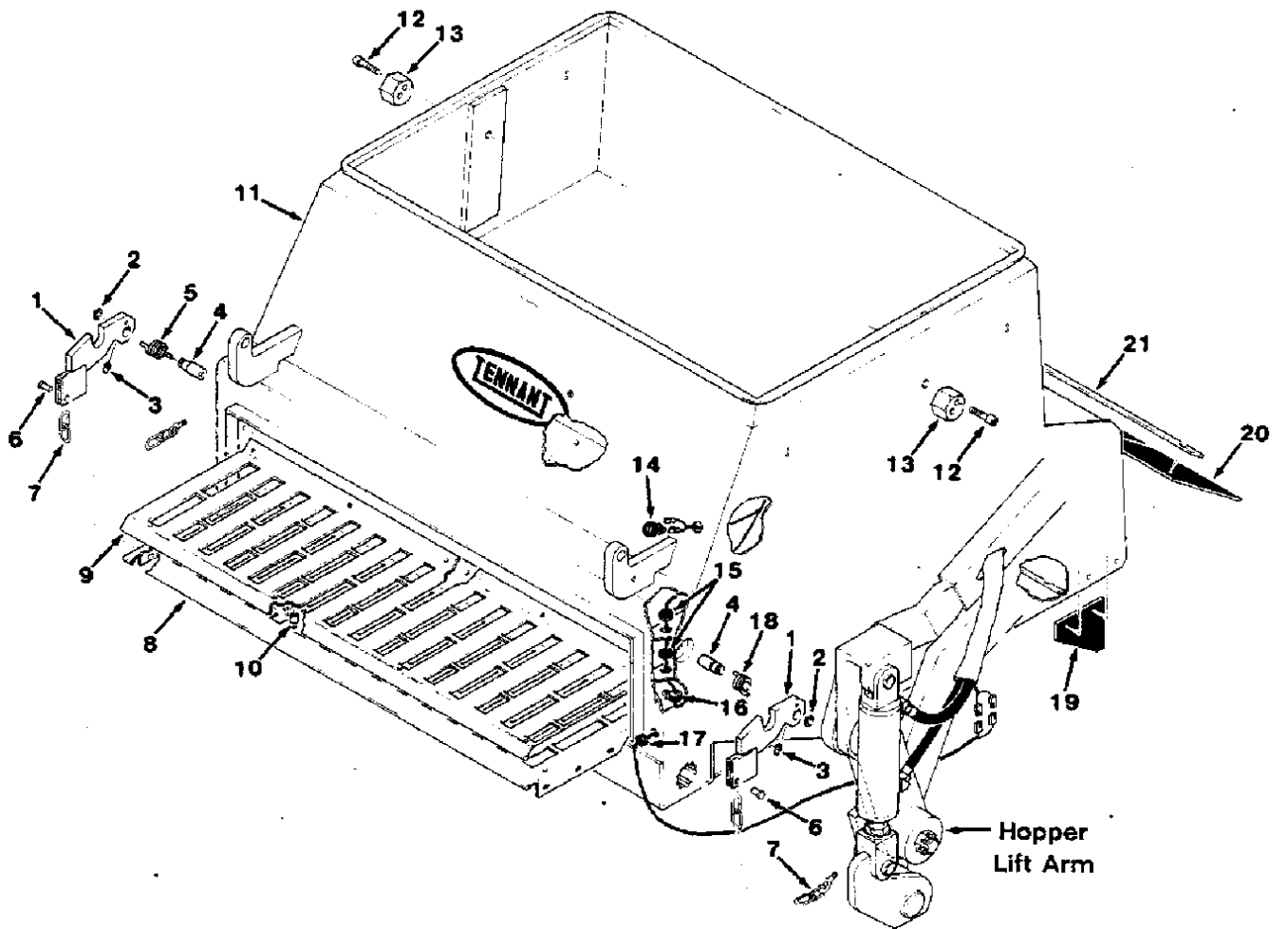

Fig. 3 - Hopper Group, SE Multi-Level Dump

Fig. 3 - Hopper Group, SE Multi-Level Dump

02584

Key	Tennant® Part No.	Machine Serial Number	Description	Qty.
1	82501	(000000-)	Latch, Door	2
2	18136	(000000-)	Ring, Retaining	2
3	07259	(000000-)	Fitting, Grease	2
4	82500	(000000-)	Shaft, Latch	2
5	48928	(000000-)	Spring, Torsion	1
6	10120	(000000-)	Pin, Clevis	2
7	32448	(000000-)	Chain Assembly	2
8	82476	(000000-)	Baffle, Lower	1
9	82477	(000000-)	Baffle, Upper	1
10	82483	(000000-)	Tube, Spacer	4
11	08000	(000000-)	Hopper	1
12	82423	(000000-)	Screw, Socket	2
13	82421	(000000-)	Cam, Positioning	2
14	39672	(000000-)	Terminal, Bushing	1
15	10632-4	(000000-)	Grommet	2
16	26395-2	(000000-)	Clamp, Cable	1
17	10632-1	(000000-)	Grommet	1
18	48927	(000000-)	Spring, Torsion	1
19	37021	(000000-)	Lip, Side	2
20	35607	(000000-)	Lip	5
21	53758	(000000-)	Strip	1

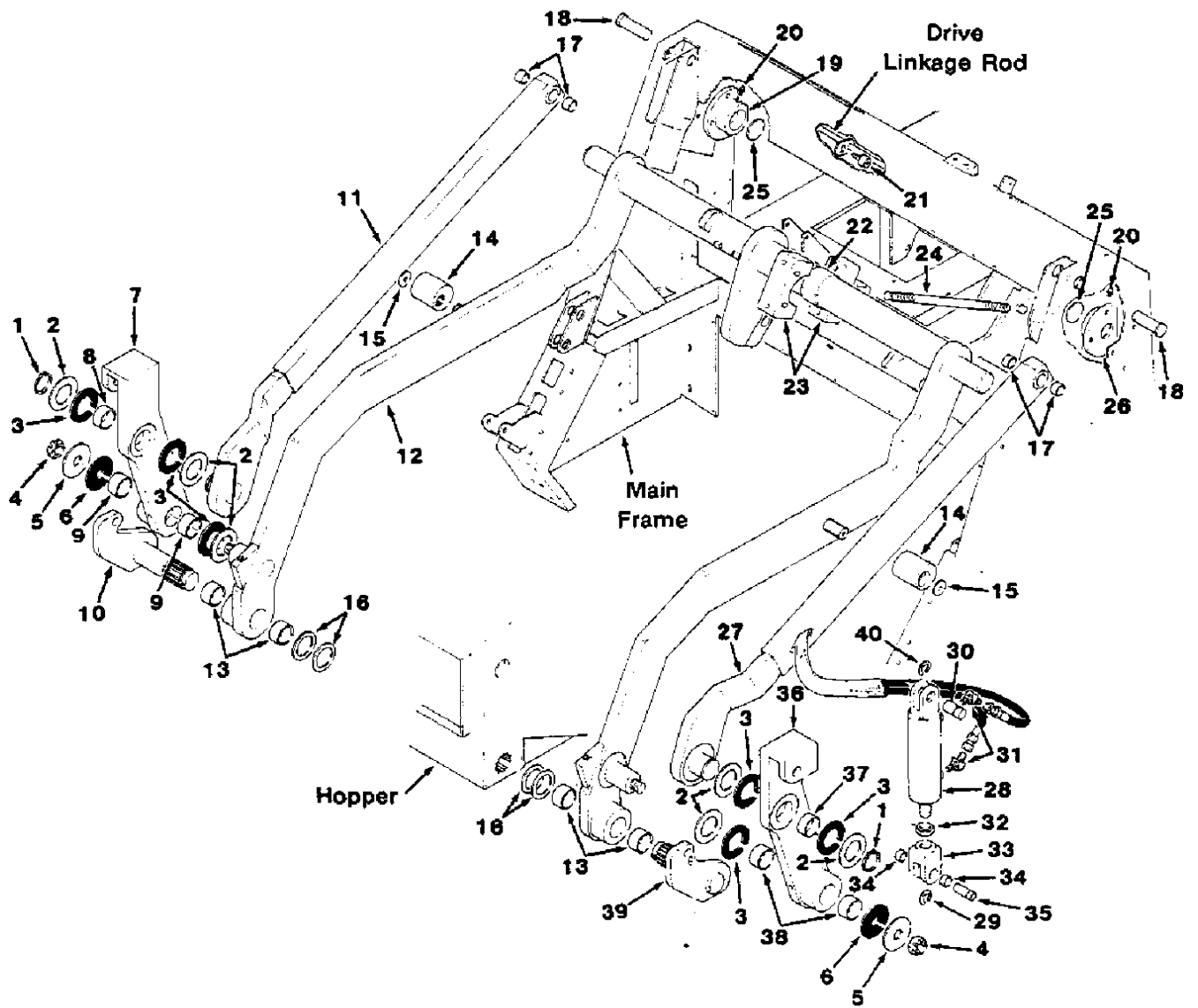

Fig. 4 - Hopper Lift Arms Group, SE Multi-Level Dump

Fig. 4 - Hopper Lift Arms Group, SE Multi-Level Dump

02562

Key	Tennant® Part No.	Machine Serial Number	Description	Qty.
1	35686	(000000-)	Ring, Retaining	2
2	35615	(000000-)	Washer	6
3	37139	(000000-)	Bearing, Thrust	6
4	14242	(000000-)	Nut, Slotted	2
5	35614	(000000-)	Washer	2
6	35666	(000000-)	Bearing, Thrust	2
7	35621-1	(000000-)	Arm Assembly, Pivot, R.H.	1
8	35665	(000000-)	Bearing, Journal	1
9	35561	(000000-)	Bearing, Journal	2
10	35640	(000000-)	Shaft, R.H.	1
11	82610	(000000-)	Arm, Upper, R.H.	1
12	82194	(000000-)	Arm Assembly, Lift	1
13	35561	(000000-)	Bearing, Journal	4
14	33541	(000000-)	Hub, Splined	2
15	36996	(000000-)	Washer	2
16	32125	(000000-)	Washer	6
17	35688	(000000-)	Bearing, Journal	4
18	34410	(000000-)	Pin, Clevis	2
19	35631	(000000-)	Bearing, R.H.	1
20	07259	(000000-)	Fitting, Grease	2
21	48930	(000000-)	Cam, Follower	1
22	35668	(000000-)	Bearing, Journal	1
23	35630	(000000-)	Bearing, Center	1
24	35595	(000000-)	Stud	1
25	23138	(000000-)	Shim	6
26	35631-1	(000000-)	Bearing, L.H.	1
27	82611	(000000-)	Arm, Upper, L.H.	1
28	82756	(000000-)	Cylinder, Hydraulic	2
29	23788-1	(000000-)	Ring, Retaining	4
30	23145	(000000-)	Pin, Grooved	2
31	34359	(000000-)	Fitting, Elbow, 45°	4
32	48988	(000000-)	Nut	2
33	37015	(000000-)	Clevis	2
34	37014	(000000-)	Bearing, Journal	2
35	37016	(000000-)	Pin, Grooved	2
36	35620-1	(000000-)	Arm Assembly, Pivot, L.H.	1
37	35665	(000000-)	Bearing, Journal	1
38	35561	(000000-)	Bearing, Journal	2
39	35636	(000000-)	Shaft, L.H.	1
40	23788	(000000-)	Ring, Retaining	2

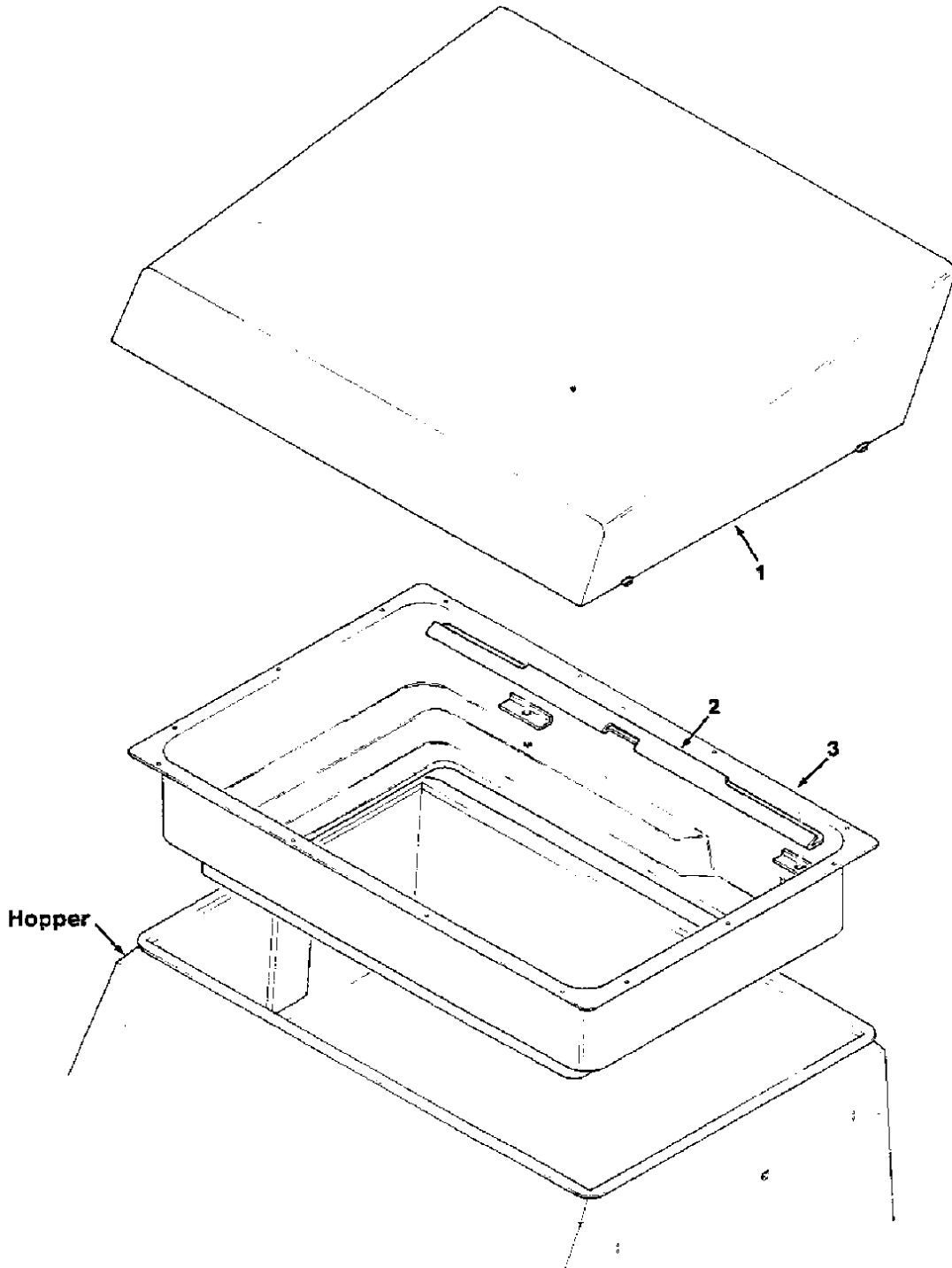

Fig. 5 - Hopper Cover and Filter Carrier Group, SE Multi-Level Dump

02573

Key	Tennant® Part No.	Machine Serial Number	Description	Qty.
1	82400	(000000-)	Cover, Filter	1
2	82452	(000000-)	Bracket, Filter Retainer	1
3	82451	(000000-)	Carrier, Filter	1

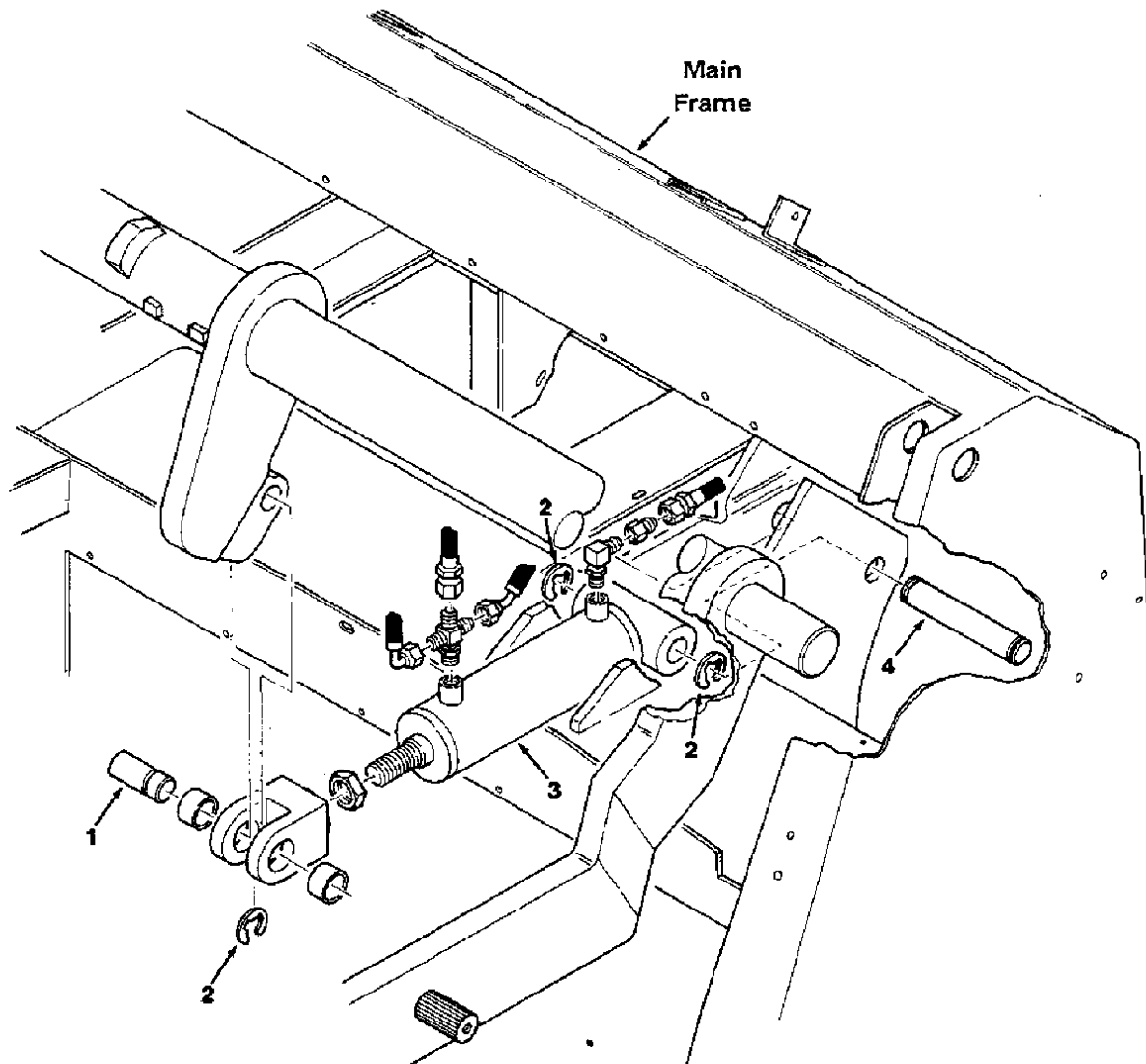

Fig. 6 - Hydraulic Lift Cylinder Group; SE Multi-Level Dump

02546

Key	Tennant® Part No.	Machine Serial Number	Description	Qty.
1	32941	(000000-)	Pin, Grooved	1
2	23788	(000000-)	Ring, Retaining	3
3	82757	(000000-)	Cylinder, Hydraulic	1
4	35515	(000000-)	Pin, Grooved	1

NOTE: To identify parts shown but not listed here, see Section 5, Low Dump Model Parts.

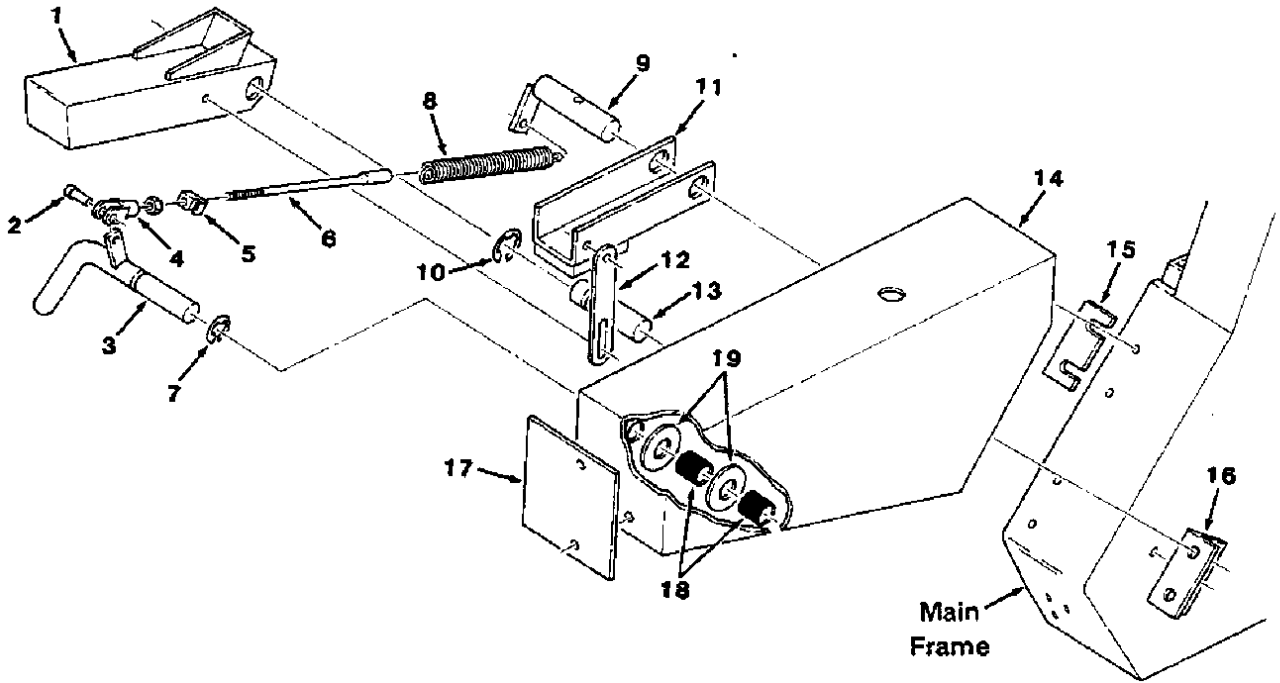

Fig. 7 - Stabilizer Leg Group, SE Multi-Level Dump

02584

Key	Tennant® Part No.	Machine Serial Number	Description	Qty.
1	35591	(000000-)	Leg, Safety	1
2	51727	(000000-)	Pin, Clevis	1
3	33568	(000000-)	Lever, Leg	1
4	14595-1	(000000-)	Clevis, Adjustable	1
5	33565	(000000-)	Lug, Adjustment	1
6	33563	(000000-)	Rod, Adjustment	1
7	23788-1	(000000-)	Ring, Retaining	1
8	33523	(000000-)	Spring, Tension	1
9	33763	(000000-)	Shaft, Stop	1
10	23788	(000000-)	Ring, Retaining	1
11	35533	(000000-)	Support, Leg	1
12	35527	(000000-)	Link	1
13	36972	(000000-)	Pin, Grooved	1
14	32282	(000000-)	Bumper, L.H.	1
15	14895	(000000-)	Shim	1
16	82189	(000000-)	Bracket, L	1
17	48951-1	(000000-)	Plate, End	4
18	36663	(000000-)	Sleeve	2
19	32495	(000000-)	Washer	2

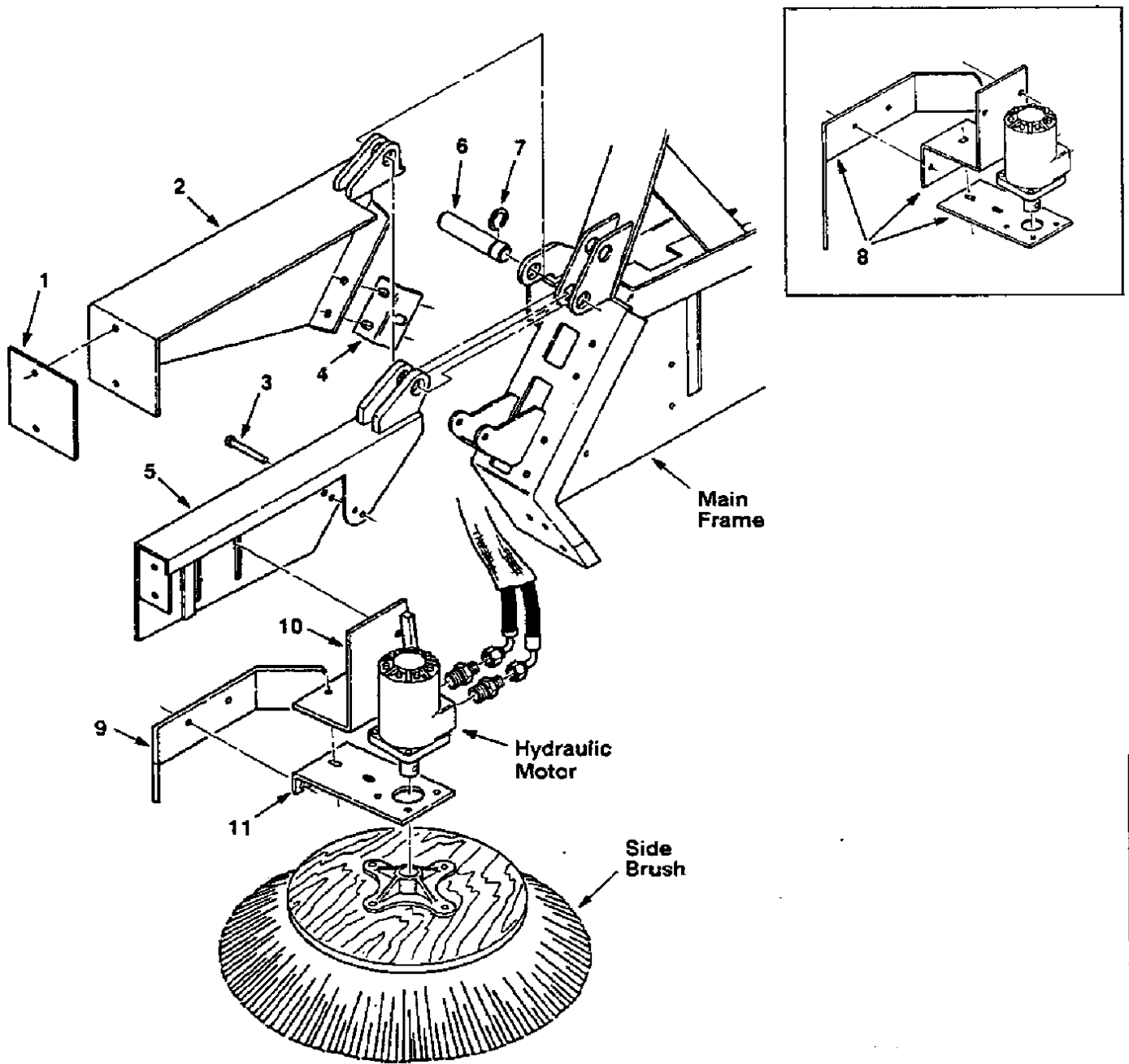

Fig. 8 - Side Brush Group, SE Multi-Level Dump

Key	Tennant® Part No.	Machine Serial Number	Description	Qty.
1	48951-1	(000000-)	Plate, End	1
2	36958	(000000-)	Bumper, R.H.	1
3	23191	(000000-)	Pin, Clevis	1
4	82189	(000000-)	Bracket, L	1
5	55662	(000000-)	Arm, Brush	1
6	36993	(000000-)	Pin, Grooved	1
7	23788	(000000-)	Ring, Retaining	1
8	33834	(000000-002294)	Replacement Kit, Side Brush Mounting	1
9	82273	(002295-)	Bumper, Side Brush	1
10	02482	(002295-)	Bracket, Bumper	1
11	82272	(002295-)	Plate, Mounting	1

NOTE: To identify parts shown but not listed here, see Section 5, Low Dump Model Parts.

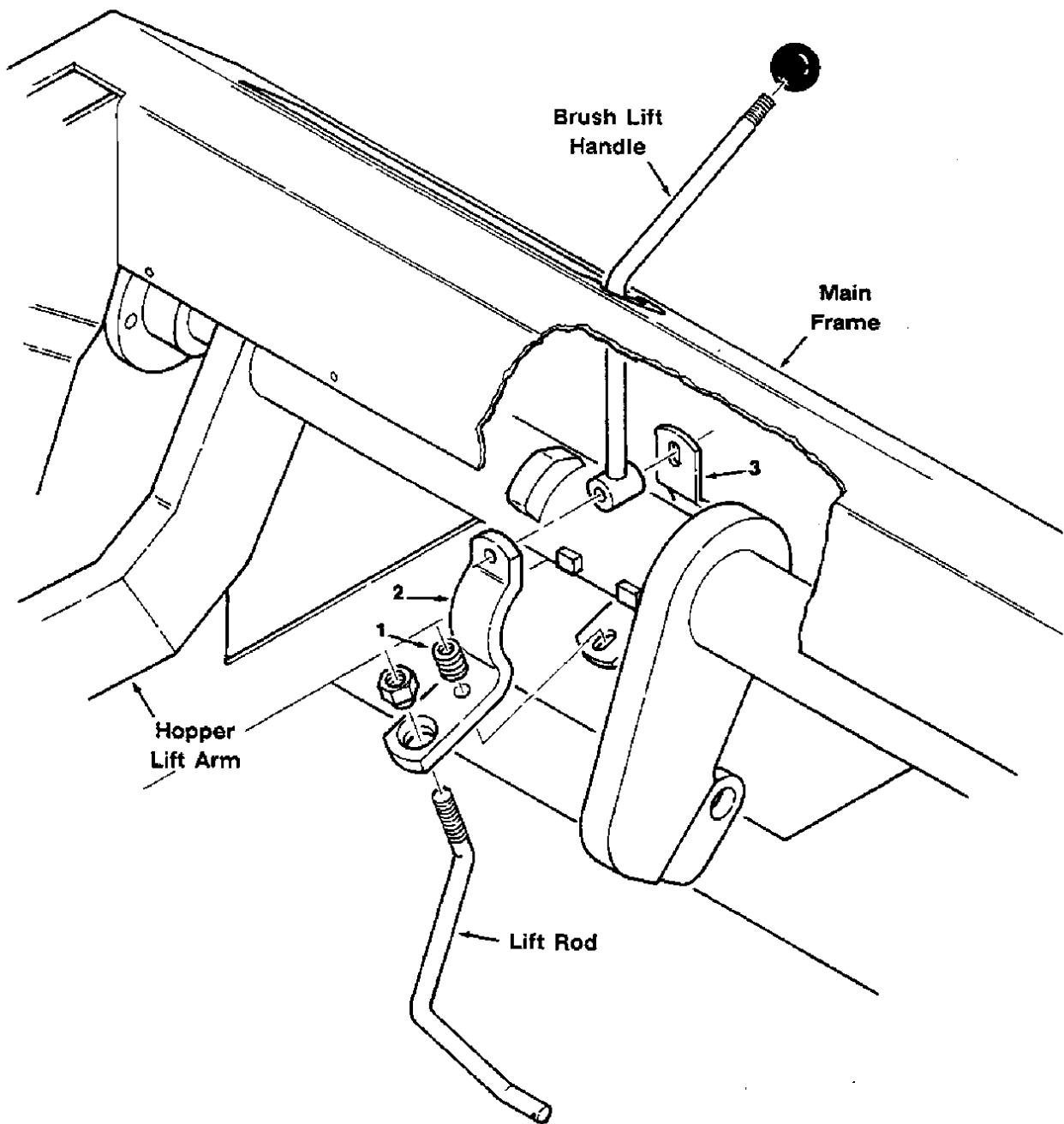

Fig. 9 - Main Brush Lift Group, SE Multi-Level Dump

02566

Key	Tennant® Part No.	Machine Serial Number	Description	Qty.
1	14174	(000000-)	Spring, Compression	1
2	53907	(000000-)	Lever, Lift Handle	1
3	53899	(000000-)	Clip, Lift Handle	1

NOTE: To identify parts shown but not listed here, see Section 5, Low Dump Model Parts.

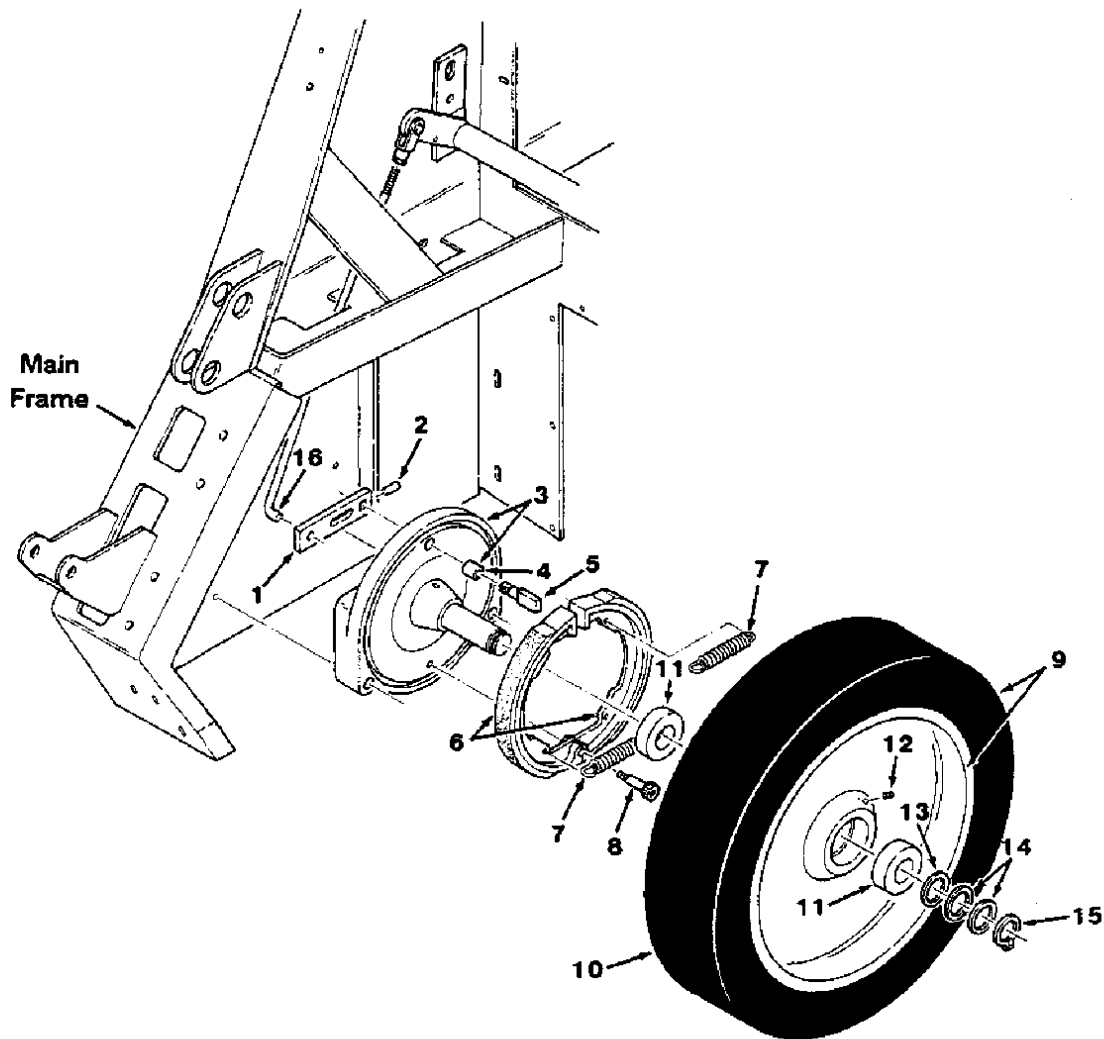

Fig. 10 - Front Wheel and Brakes Group, SE Multi-Level Dump

04184

Key	Tennant® Part No.	Machine Serial Number	Description	Qty.
	82232	(000000-)	Axle Assembly, Front	2
1	23484	(000000-)	Arm	1
2	20021	(000000-)	Pin, Roll	1
3	08108	(000000-003135)	Replacement Kit, Front Axle	1
3	08107	(003136-)	Axle, Front	1
4	24992	(000000-)	Bushing, Sleeve	1
5	23272	(000000-)	Cam	1
6	56058	(000000-)	Brake Assembly	2
7	09758	(000000-)	Spring, Tension	2
8	56060	(000000-)	Screw, Shoulder	1
9	82230	(000000-)	Wheel Assembly, Front	2
9	82238	(000000-)	Wheel and Tire Assembly	1
10	25197A	(000000-)	Tire	1
11	33816	(000000-)	Bearing, Ball	2
12	10552	(000000-)	Plug	1
13	82226	(000000-)	Washer	2
14	82227	(000000-)	Washer	4
15	06442	(000000-)	Ring, Retaining	2
16	82219	(000000-)	Rod, Control	2

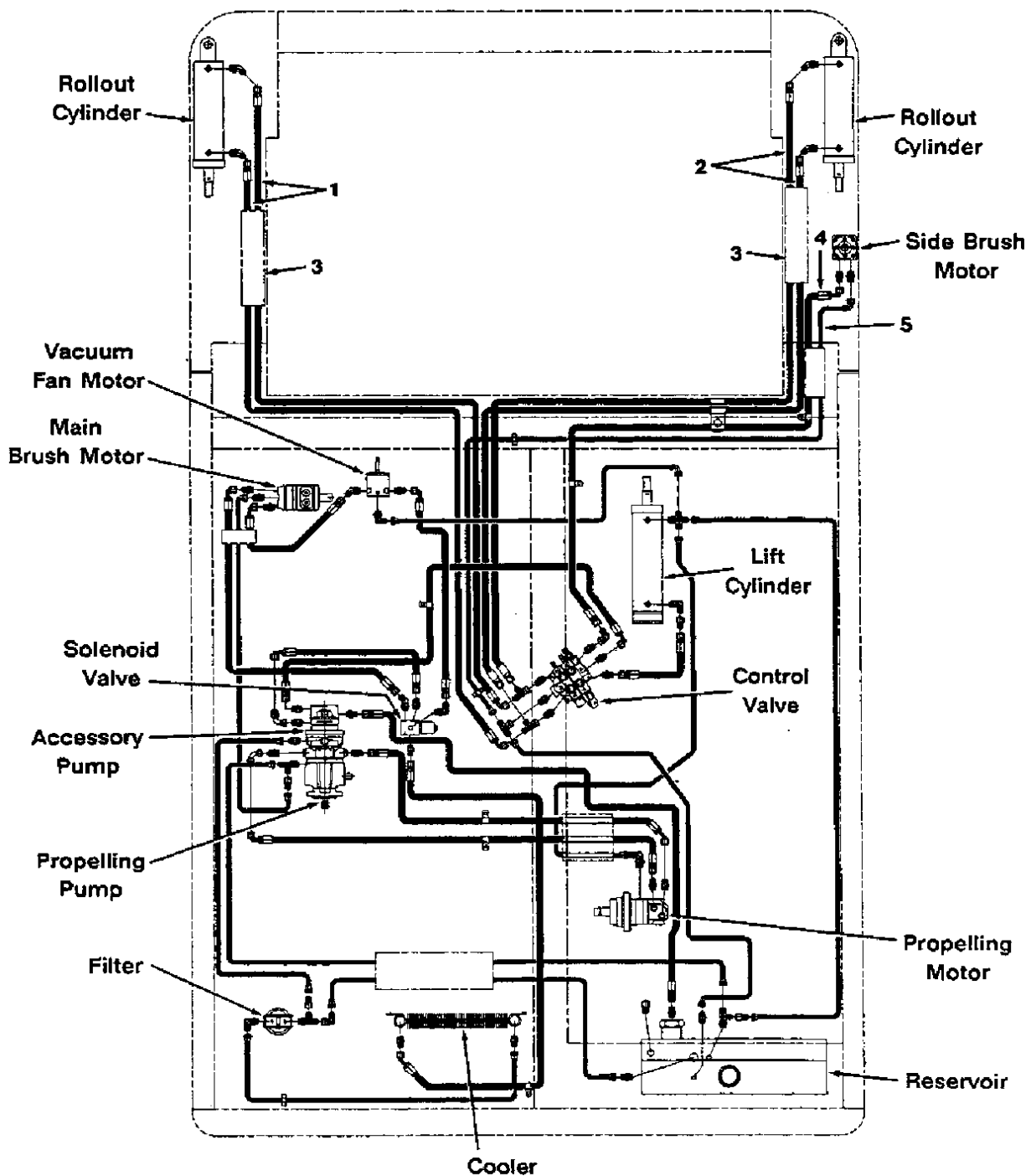

Fig. 11 - Hydraulic Hoses Group, SE Multi-Level Dump

02583

Key	Tennant® Part No.	Machine Serial Number	Description	Qty.
1	82817	(000000-)	Hose, Hydraulic	2
2	82815	(000000-)	Hose, Hydraulic	2
3	82834	(000000-)	Sleeve, Hose	2
4	82816	(000000-)	Hose, Hydraulic	1
5	82808	(000000-)	Hose, Hydraulic	1

NOTE: To identify parts shown but not listed here, see Section 5, Low Dump Model Parts.

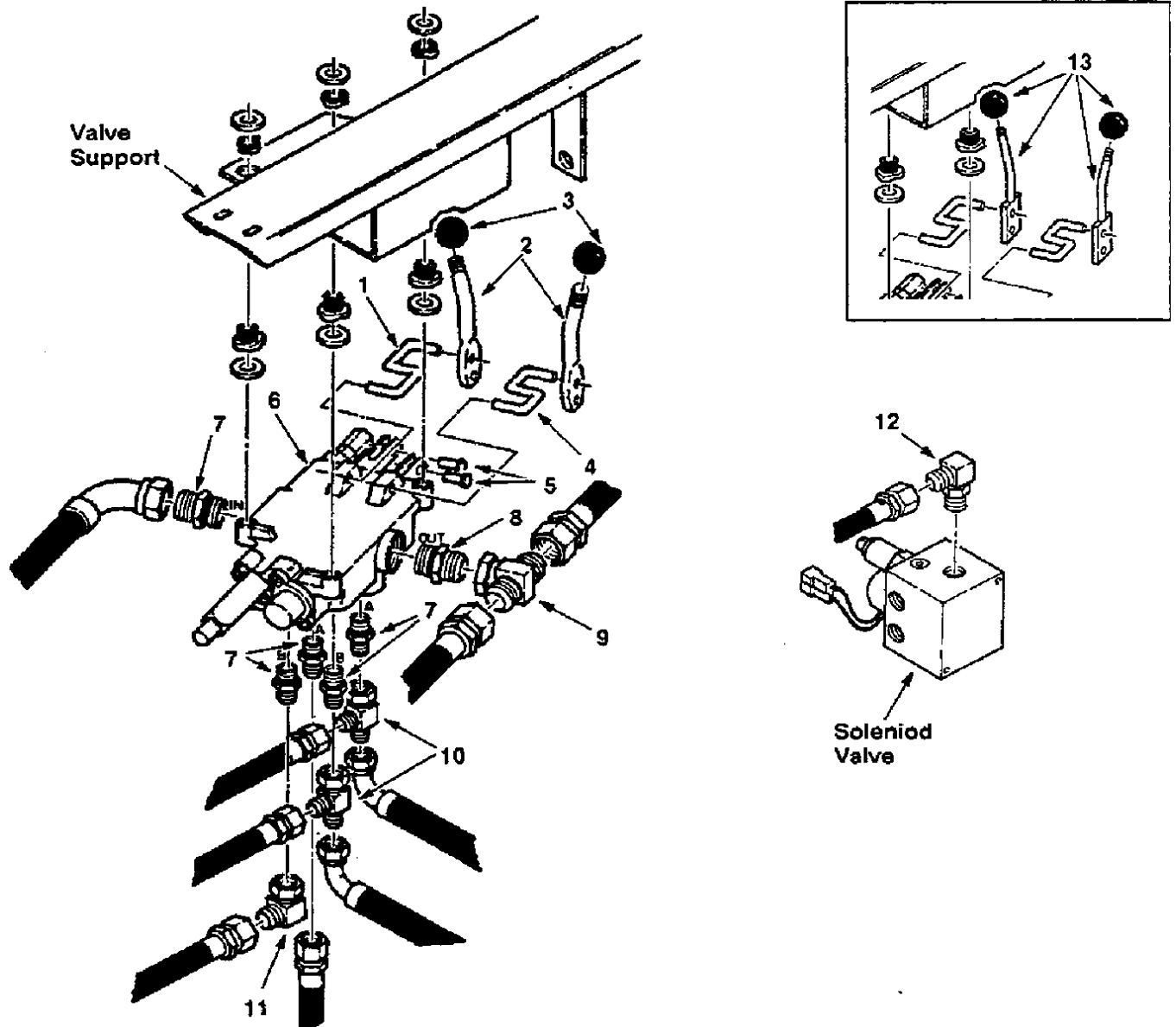

Fig. 12 - Hydraulic Control Valve Group, SE Multi-Level Dump

04503

Key	Tennant® Part No.	Machine Serial Number	Description	Qty.
1	82762	(000000-)	Link, Hook	1
2	02687	(003438-)	Handle, Valve	2
3	26156	(003438-)	Knob	2
4	32759	(000000-)	Link, Hook	1
5	14605	(000000-)	Pin, Clevis	2
6	34319	(000000-)	Valve, Hydraulic	1
7	55686	(000000-)	Fitting, Straight	5
8	52402	(000000-)	Fitting, Straight	1
9	35586	(000000-)	Fitting, Tee	1
10	57988	(000000-)	Fitting, Tee	2
11	39210	(000000-)	Fitting, Elbow	1
12	44868	(000000-)	Fitting, Elbow	1
13	02688	(000000-003437)	Replacement Kit, Handle	2

NOTE: To identify parts shown but not listed here, see Section 5, Low Dump Model Parts.

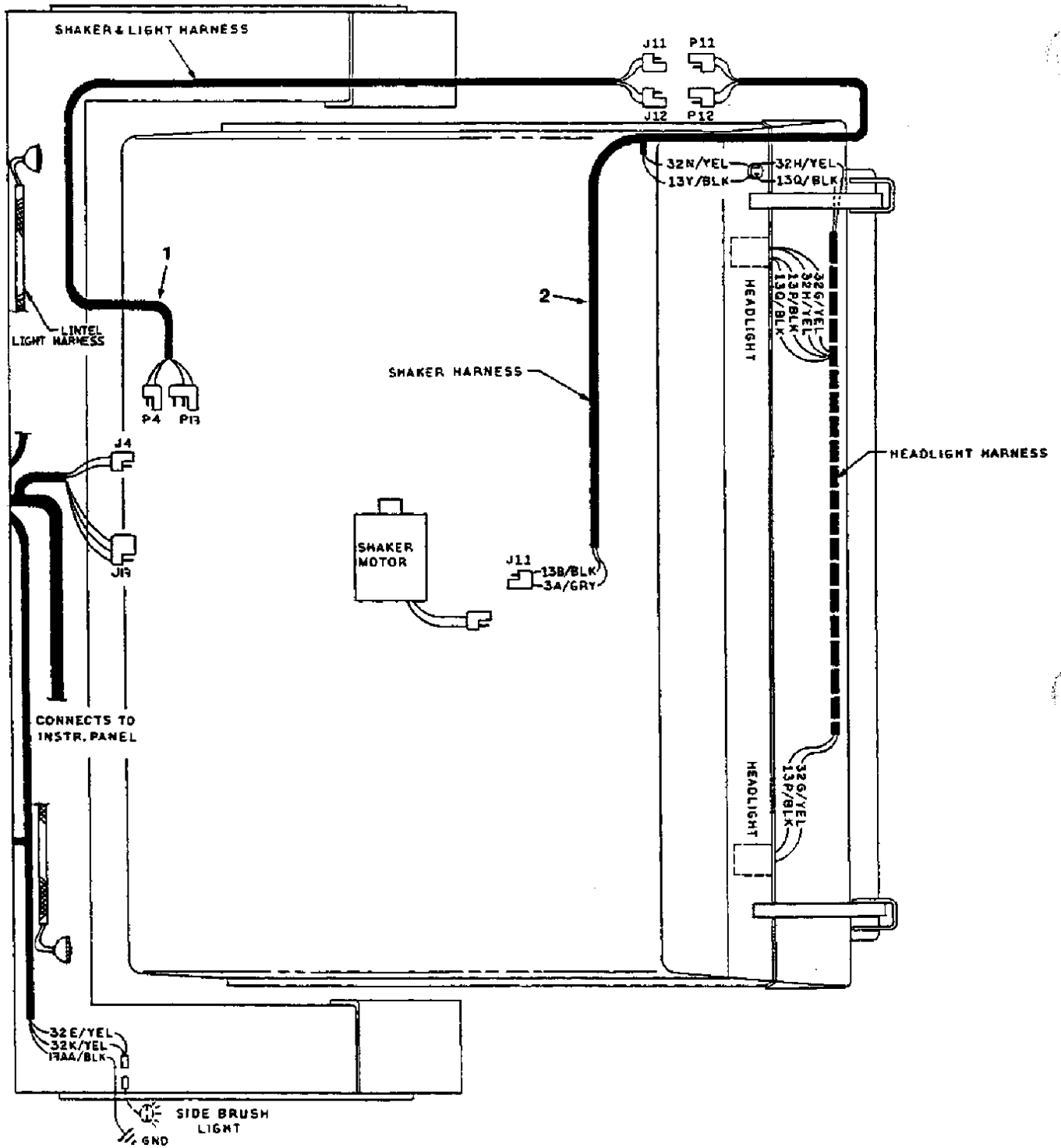

Fig. 13 - Wire Harnesses Group, SE Multi-Level Dump

02549

Key	Tennant® Part No.	Machine Serial Number	Description	Qty.
1	82704	(000000-)	Wire Harness, Shaker	1
2	82724	(000000-)	Wire Harness, Hopper	1

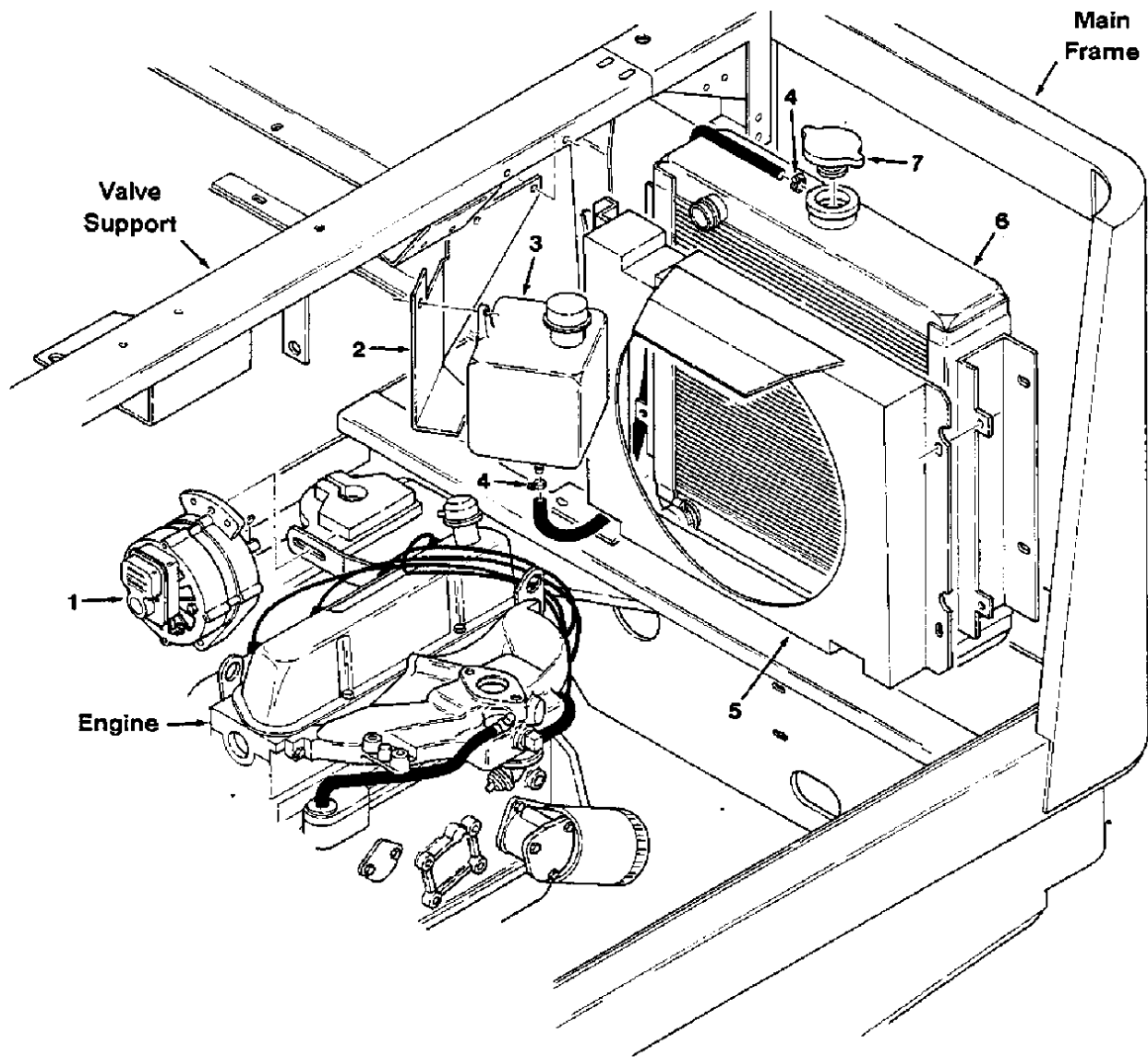

Fig. 14 - Alternator and Radiator Group, SE Multi-Level Dump

02720

Key	Tennant® Part No.	Machine Serial Number	Description	Qty.
1	82511	(000000-)	Alternator	1
2	82699	(000000-)	Bracket, Tank	1
3	82694	(000000-)	Tank, Coolant Recovery	1
4	43844	(000000-)	Clamp, Worm Drive	2
5	82256	(000000-)	Shroud Assembly, Fan	1
6	82653	(000000-)	Radiator	1
7	82688	(000000-)	Cap, Radiator	1
	51305	(000000-)	Drain Cock, Radiator	1

NOTE: To identify parts shown but not listed here, see Section 5, Low Dump Model Parts.

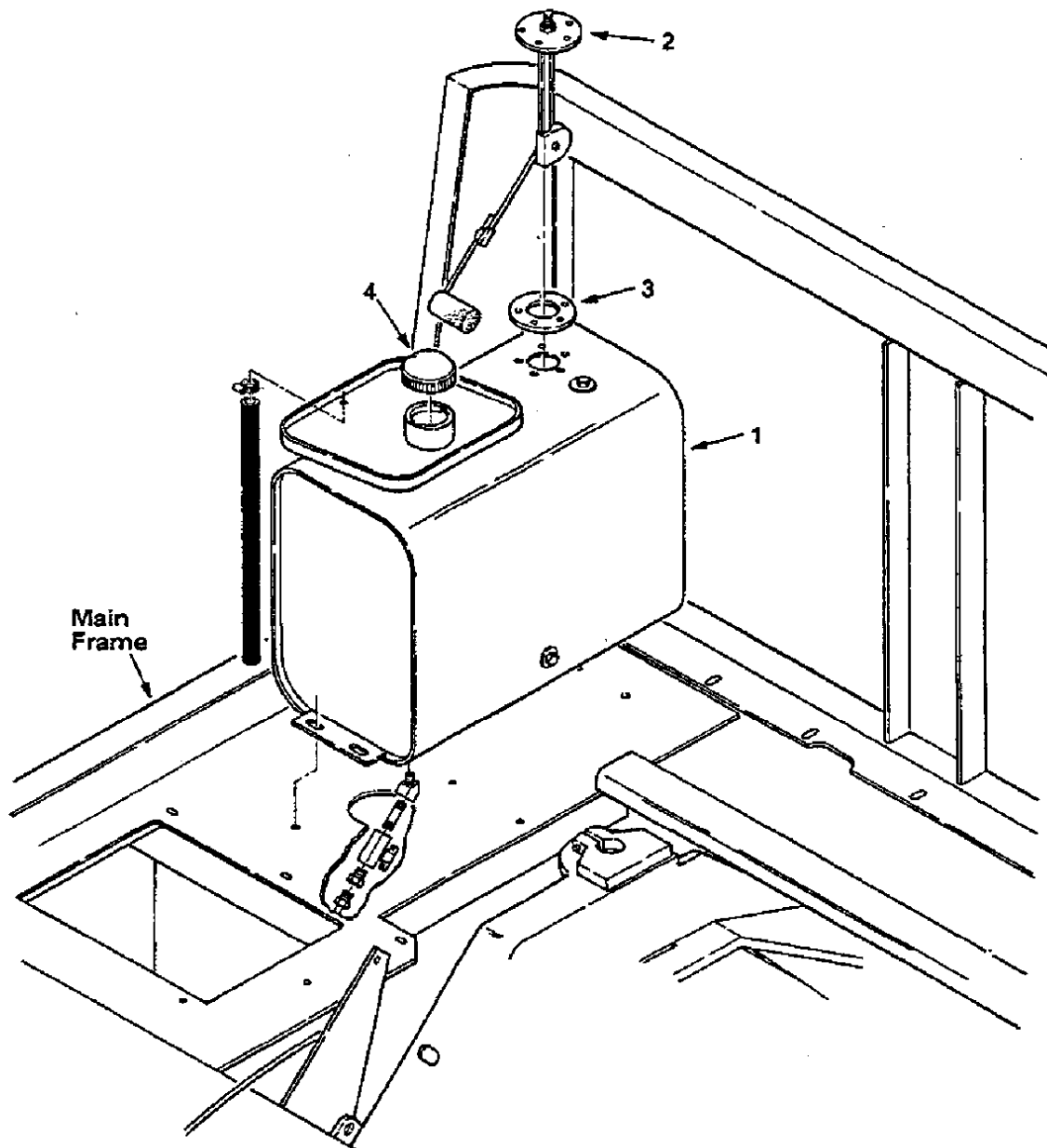

Fig. 15 - Fuel Tank Group, SE Multi-Level Dump

02717

Key	Tennant® Part No.	Machine Serial Number	Description	Qty.
1	82729	(000000-)	Tank, Fuel	1
2	47473	(000000-)	Sending Unit, Tank	1
	68106	(000000-)	Terminal, Tab	1
3	14131	(000000-)	Gasket	1
4	48267	(000000-)	Cap, Tank	1

NOTE: To identify parts shown but not listed here, see Section 5, Low Dump Model Parts.

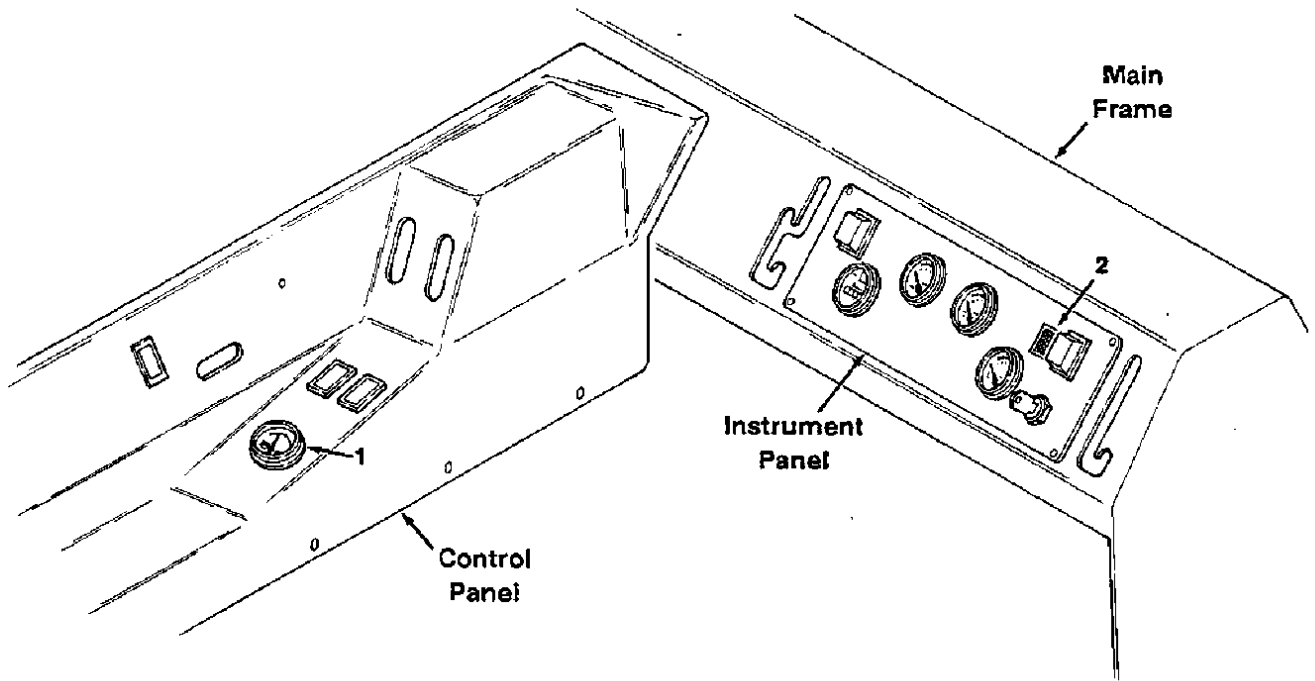

Fig. 16 - Instrument Panels Group, SE Multi-Level Dump

02718

Key	Tennant® Part No.	Machine Serial Number	Description	Qty.
1	34813	(000000-)	Gauge, Fuel	1
2	64141-1	(000000-)	Light Assembly	1

Note: To identify parts shown but not listed here, see Section 5, Low Dump Model Parts.

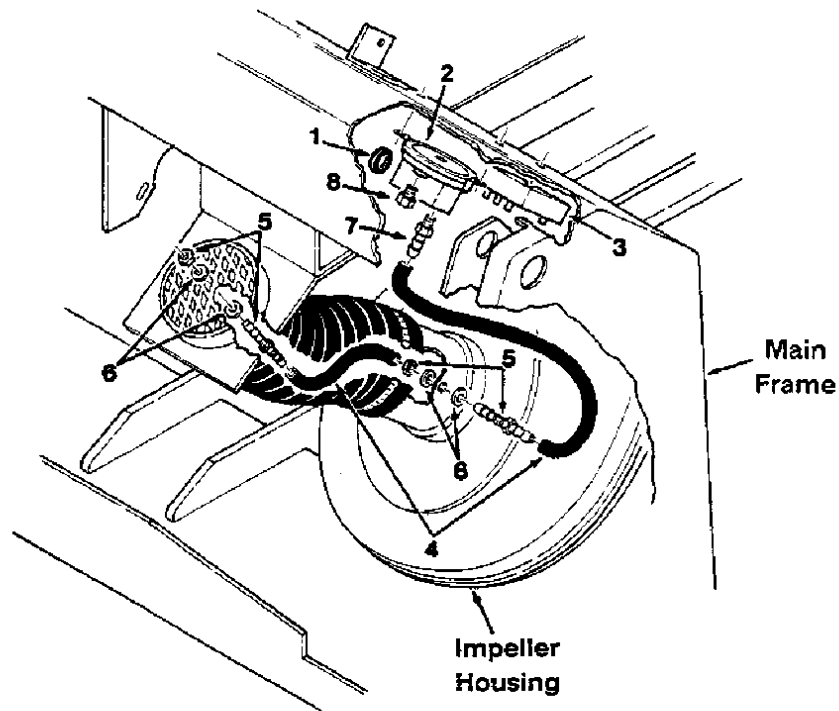

Fig. 17 - Pressure Switch Group, SE Multi-Level Dump

02739

Key	Tennant® Part No.	Machine Serial Number	Description	Qty.
1	10632-4	(000000-)	Grommet	1
2	34868	(000000-)	Switch, Pressure	1
3	34816	(000000-)	Timer, Shaker	1
4	39780-1	(000000-)	Hose, Rubber	1
5	39923	(000000-)	Fitting, Bulkhead, Barbed	2
6	43454	(000000-)	Washer, Nylon	4
7	40607	(000000-)	Fitting, Straight	1
8	82739	(000000-)	Fitting, Breather	1

NOTE: To identify parts shown but not listed here, see Section 5, Low Dump Model Parts.

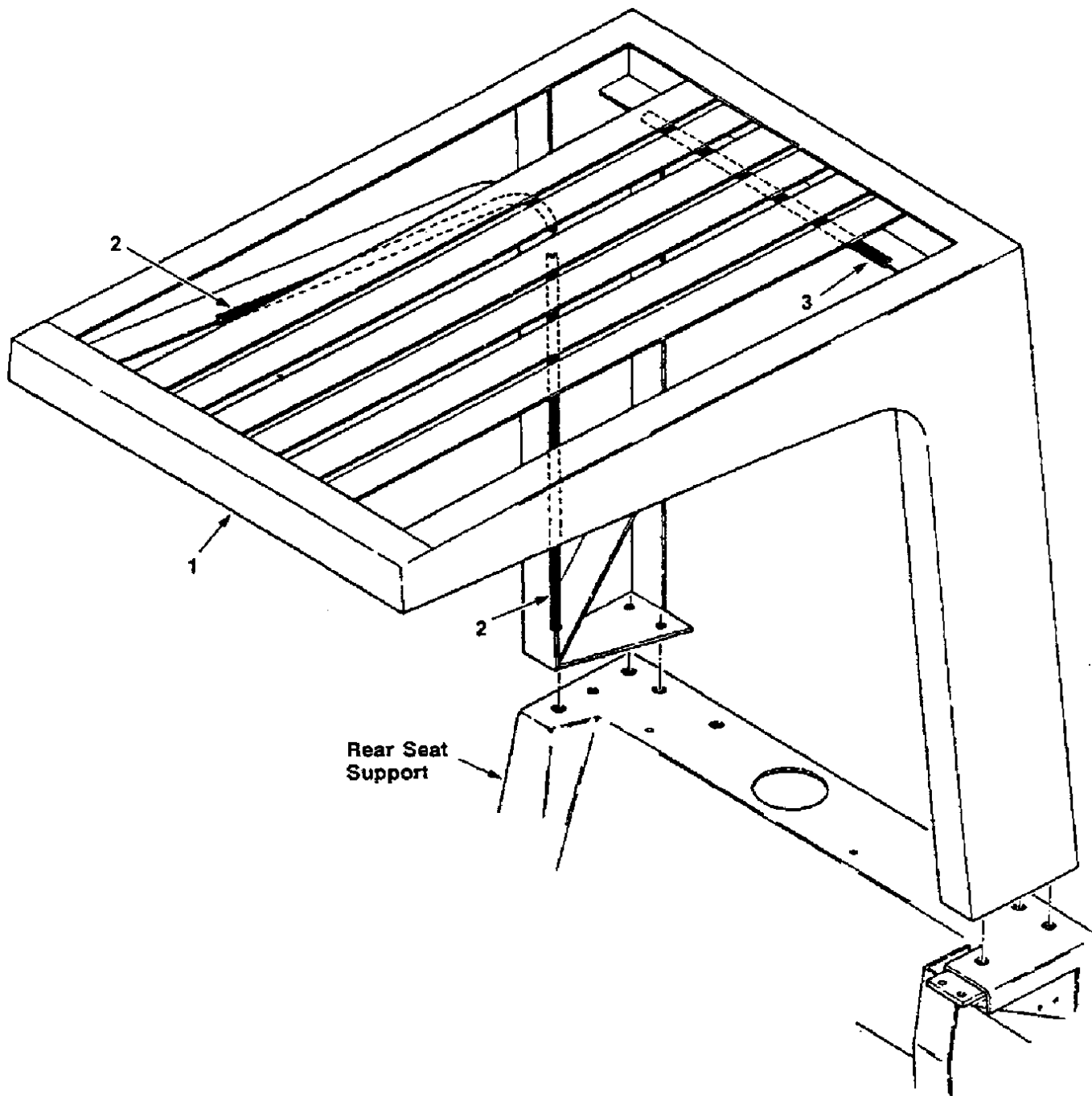

Fig. 18 - Overhead Guard Group, SE Multi-Level Dump

c2807

Key	Tennant® Part No.	Machine Serial Number	Description	Qty.
1	55150	(000000-)	Guard, Overhead	1
2	62595-11	(003417-)	Rigid Molding	2
3	62595-2	(003417-)	Rigid Molding	1

NOTE: To identify parts shown but not listed here, see Section 5, Low Dump Model Parts.

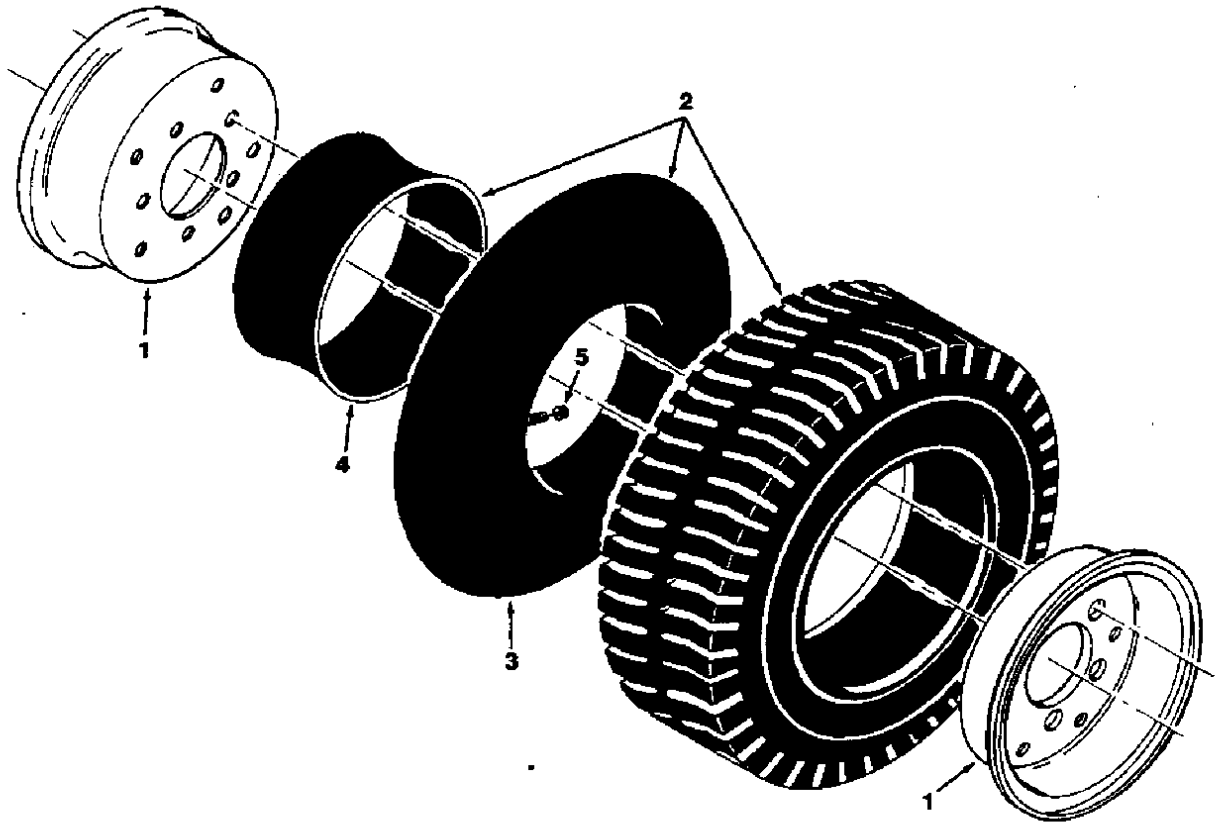

Fig. 19 - Rear Wheel Assembly, SE Multi-Level Dump

02588

Key	Tennant® Part No.	Machine Serial Number	Description	Qty.
1	53640	(000000-)	Tire and Wheel Assembly, Steelguard	1
	53818	(000000-)	Rim	1
2	53819	(000000-)	Tire, Tube and Flap Assembly	1
3	53819-1	(000000-)	Tube, Inner	1
4	53819-2	(000000-)	Flap, Tube	1
5	45786	(000000-)	Cap, Valve Stem	1

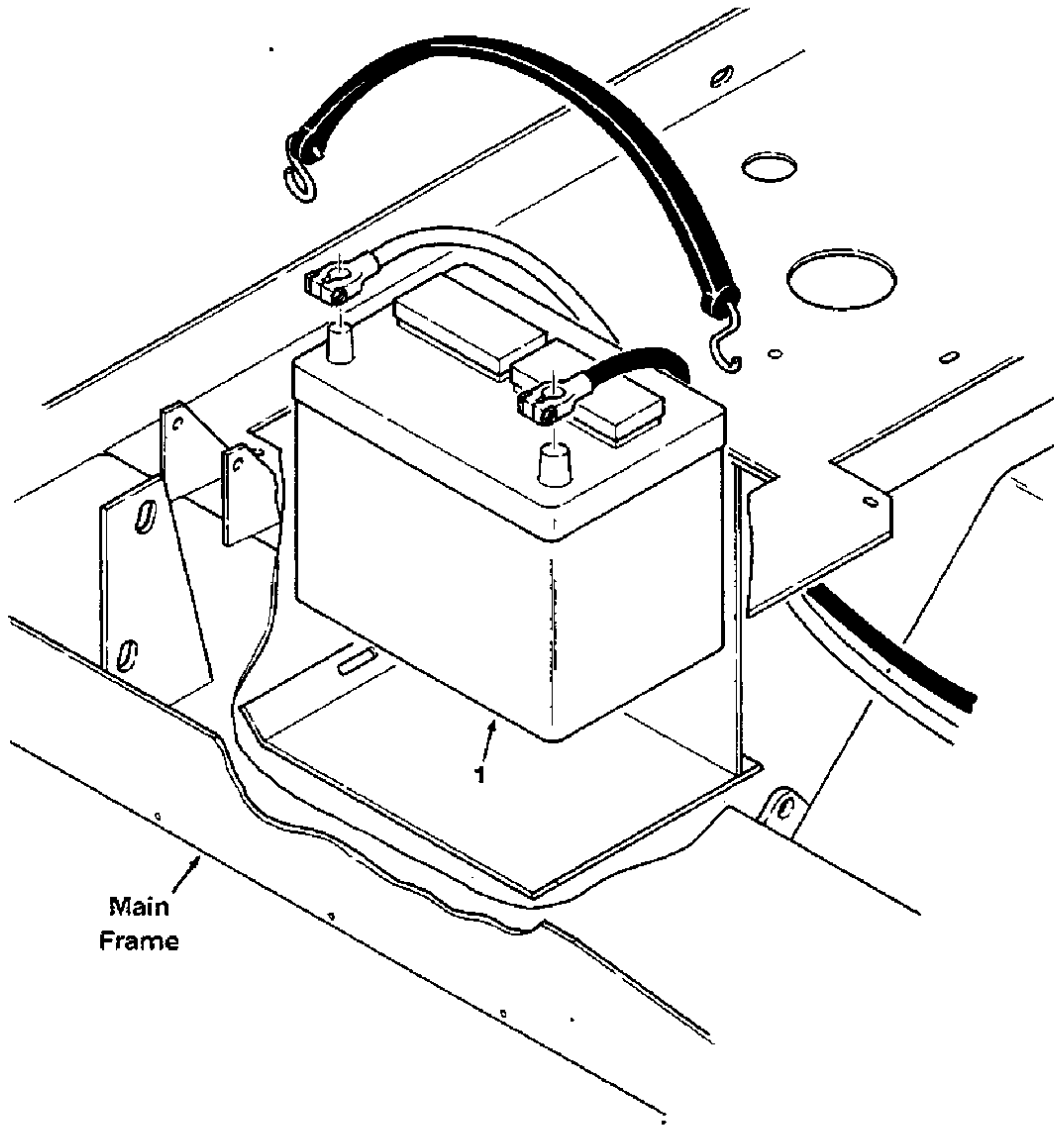

Fig. 20 - Battery Group, SE Multi-Level Dump

02796

Key	Tennant® Part No.	Machine Serial Number	Description	Qty.
1	10143	(000000-)	Battery, 540 CAA	1

NOTE: To identify parts shown but not listed here, see Section 5, Low Dump Model Parts.

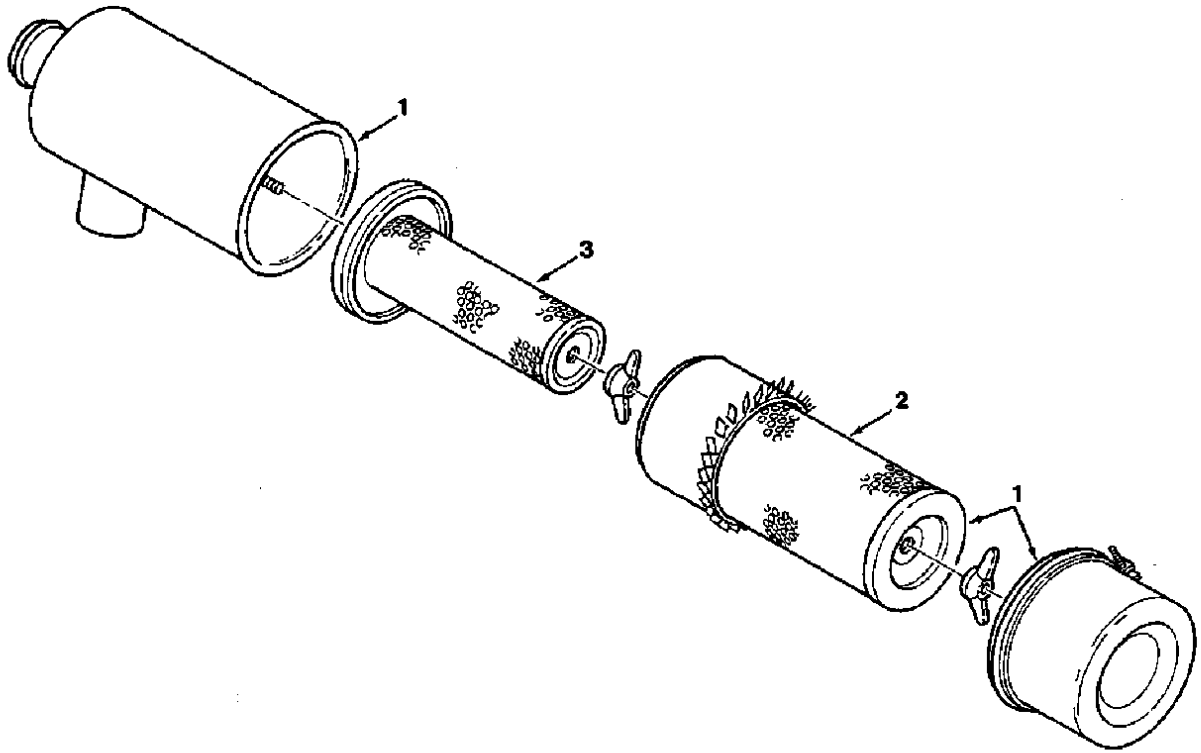

Fig. 21 - Air Cleaner Group, SE Multi-Level Dump

02274

Key	Tennant® Part No.	Machine Serial Number	Description	Qty.
	58539	(000000-)	Air Cleaner, Heavy Duty	1
1	58538	(000000-)	Body, Air Cleaner	1
2	58120	(000000-)	Element, Air Cleaner	1
3	58121	(000000-)	Element, Safety	1

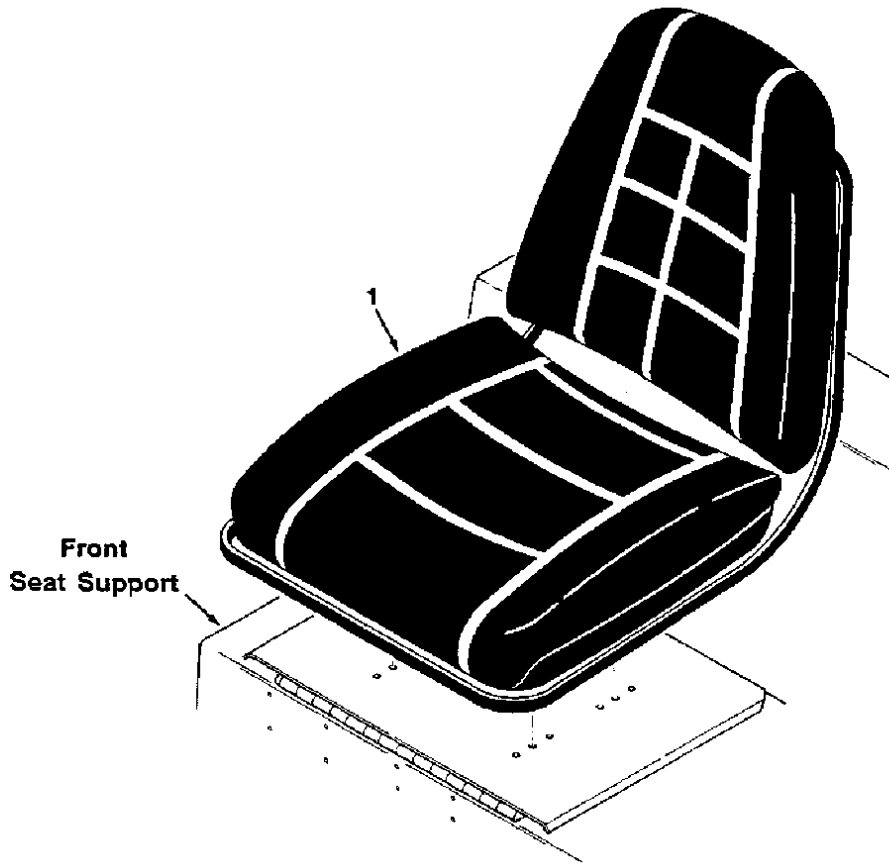

Fig. 22 - Suspension Seat Group, SE Multi-Level Dump

Key	Tennant® Part No.	Machine Serial Number	Description	Qty.
1	82343	(000000-)	Seat, Suspension	1

02809

NOTE: To identify parts shown but not listed here, see Section 5, Low Dump Model Parts.

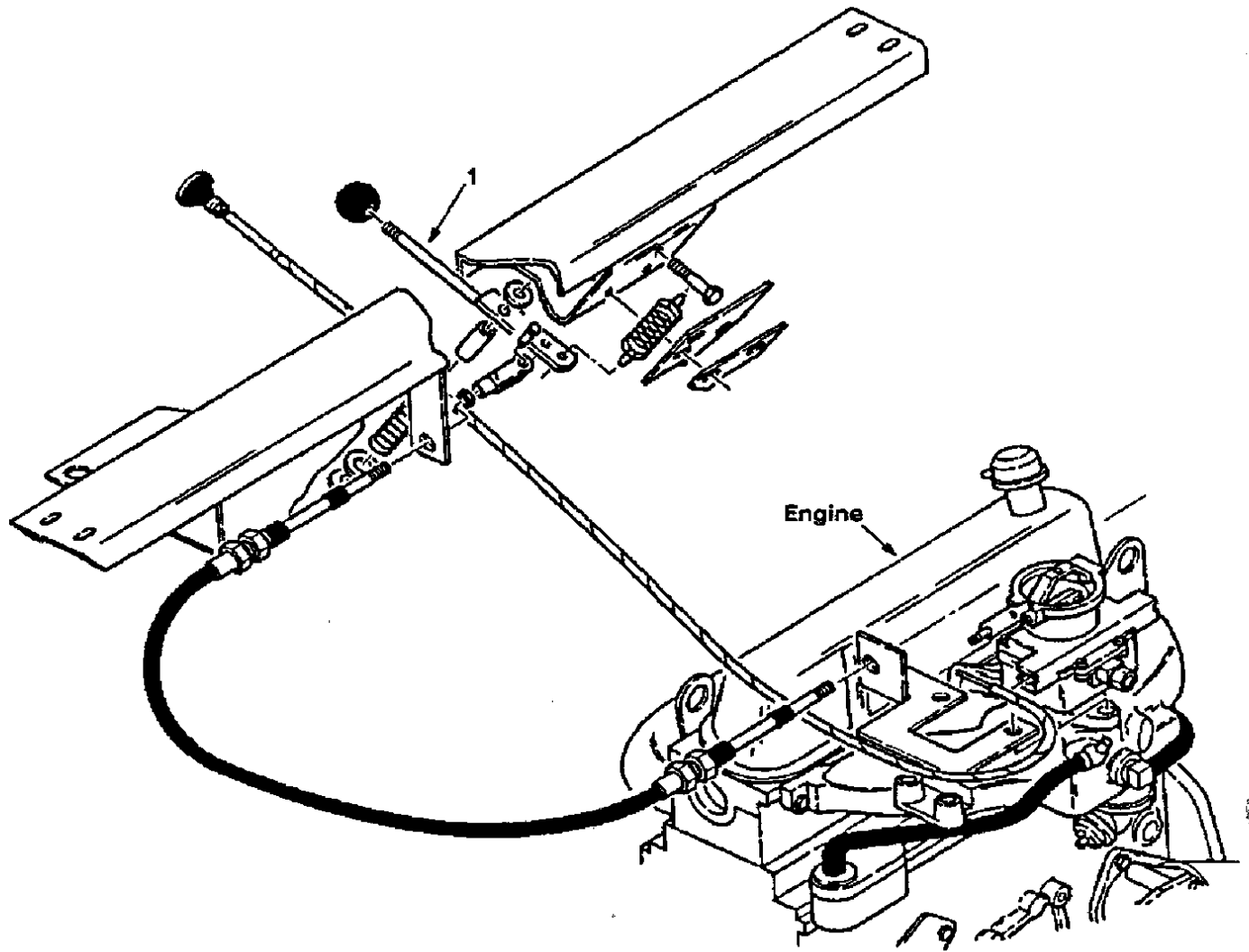

Fig. 23 - Throttle Linkage Group Multi-Level Dump

Key	Tennant® Part No.	Machine Serial Number	Description	Qty.
1	82941	(000000-)	Handle	1

04614

SECTION 11 ACCESSORIES

CONTENTS

	Page		Page
Ordering Repair Parts	11-1	Fig. 35 - Air Cleaner Kit, Heavy Duty	11-51
Fig. 1 - Cab Kit	11-2	Fig. 36 - Clogged Filter Indicator Kits	11-52
Fig. 2 - Cab Kit, SE	11-4	Fig. 37 - Dry Battery Kit	11-53
Fig. 3 - Snow Blade Kit	11-6	Fig. 38 - Fuel Gauge Kit	11-54
Fig. 4 - Snow Broom Kit	11-8	Fig. 39 - Battery Hold Down Kit	11-55
Fig. 5 - Headlight, Taillight, and Spotlight Kit, Lintel	11-10	Fig. 40 - Rear Wheel Assembly, Steelguard	11-56
Fig. 6 - Headlight, Taillight, and Spotlight Kit, Low Dump	11-12	Fig. 41 - Rear Wheel Assembly, Foam Filled	11-57
Fig. 7 - Headlight, Taillight, and Spotlight Kit, Multi-Level Dump	11-14	Fig. 42 - Rear Wheel Assembly, Solid	11-57
Fig. 8 - Revolving Light Kit, Overhead Guard	11-16	Fig. 43 - Tire Chain Kit	11-58
Fig. 9 - Flashing Light Kit, Overhead Guard	11-17	Fig. 44 - Front Wheel Assembly, Low Dump	11-58
Fig. 10 - Revolving Light Kit, Shroud	11-18	Fig. 45 - Fire Extinguisher Kit	11-59
Fig. 11 - Flashing Light Kit, Shroud	11-19	Fig. 46 - Alternator Kit	11-59
Fig. 12 - Revolving Light Kit, Cab	11-20	Fig. 47 - Suspension Seat Kit	11-60
Fig. 13 - Flashing Light Kit, Cab	11-21	Fig. 48 - Spark Arresting Muffler Kit	11-60
Fig. 14 - Mount Frame Kit	11-22	Fig. 49 - Hood Latch and Machine Tie-Down Kit	11-61
Fig. 15 - Overhead Guard Kit	11-23	Fig. 50 - Protectoseal Fuel Tank Cap Kit ..	11-62
Fig. 16 - Rear Squeegee Group	11-24	Fig. 51 - LPG Fuel Tanks Group	11-62
Fig. 17 - Rear Squeegee Update Group	11-26	Fig. 52 - Thermostat Kit	11-63
Fig. 18 - Side Squeegee Group	11-28	Fig. 53 - Extra Reach Side Brush Group Low Dump	11-64
Fig. 19 - Tire and Wheel Assembly	11-29	Fig. 54 - Extra Reach Side Brush Group Multi-Level Dump	11-66
Fig. 20 - Front Wheel Assembly	11-29		
Fig. 21 - Scrubber Brush Drive Group	11-30		
Fig. 22 - Solution Tanks Group	11-32		
Fig. 23 - Recovery Tanks Group	11-34		
Fig. 24 - Scrub Attachment Shroud Group ..	11-36		
Fig. 25 - Hopper Dolly Assembly	11-37		
Fig. 26 - Main Scrubber Brush Group	11-38		
Fig. 27 - Instrument Panel Group	11-38		
Fig. 28 - Scrubber Bumper Group	11-39		
Fig. 29 - Vacuum Wand Kit, Low Dump	11-40		
Fig. 30 - Vacuum Wand Group, Multi-Level Dump	11-42		
Fig. 31 - Side Brush Dust Control Kit, Low Dump	11-44		
Fig. 32 - Side Brush Dust Control Kit (with Hopper), Multi-Level Dump	11-46		
Fig. 33 - Side Brush Dust Control Kit, Multi-Level Dump	11-48		
Fig. 34 - Bumper Group, SE Side Brush Dust Control	11-50		

NOTE: Section 11, Accessories, lists repair parts included as part of the available accessories.

ORDERING REPAIR PARTS

The components used in this machine have been carefully selected for performance and safety. Use only Tennant Company specified or equivalent parts.

To receive prompt service in filling of your parts orders, please direct all orders for parts with Tennant Company part numbers to the Tennant Company, and all orders for parts with vendor part numbers to the local supplier of the respective vendor.

When ordering parts, please furnish all of the following information:

1. Machine model number - shown on the machine data plate.

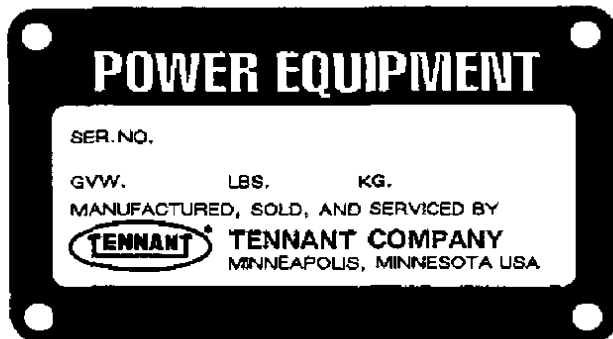

2. Machine serial number - shown on the machine data plate.
3. Engine type - gasoline, LPG, diesel, electric.
4. Company name.
5. Shipping address.
6. Billing address.
7. Name, first and last - of person ordering parts.
8. Telephone number.
9. Purchase order number.
10. Part number, description, and quantity - of each item on the order.

Do not order parts by key number or the figure number of the illustrated parts. Indented items indicate parts of assemblies. Standard hardware is furnished only when part of a purchased assembly. Please get hardware from a local hardware supplier.

If the old part cannot be identified, send it to us with the quantity needed specified on the order.

Any claim for loss or damage to a shipment in transit should be filed promptly against the transportation company making the delivery. Shipments will be complete unless the packing list or order acknowledgement indicate items back ordered.

If parts received are suspected to be incorrect or defective, please write, wire, or phone the Tennant Company representative from whom you ordered the part. They will give authorization for return and/or handle replacement shipments when required.

SERIAL NUMBER INFORMATION EXPLANATION

Serial number listings are shown to indicate on which machines each part can be used. These listings are explained by the following examples:

(000000-) The part can be used on all machines.

(003342-) The part can be used on all machines beginning with the serial number listed.

(000000-004320) The part can be used on all machines up to and including serial number listed.

(004321-005678) The part can be used on all machines between and including the serial numbers listed.

Where xxxxx's are listed in place of a serial number, it indicates a change was made but the exact serial number had not been established when the catalog went to press.

SI UNITS OF MEASURE (INTERNATIONAL SYSTEM)

Metric equivalents have been included, where applicable, throughout this parts catalog.

FASTENER STRENGTH IDENTIFICATION

Fasteners required to have high-strength qualities equivalent to SAE Grade 8 are identified throughout this catalog by the description GR 8. Unless identified by this description, all standard fasteners are SAE Grade 5.

(Specifications and design subject to change without notice.)

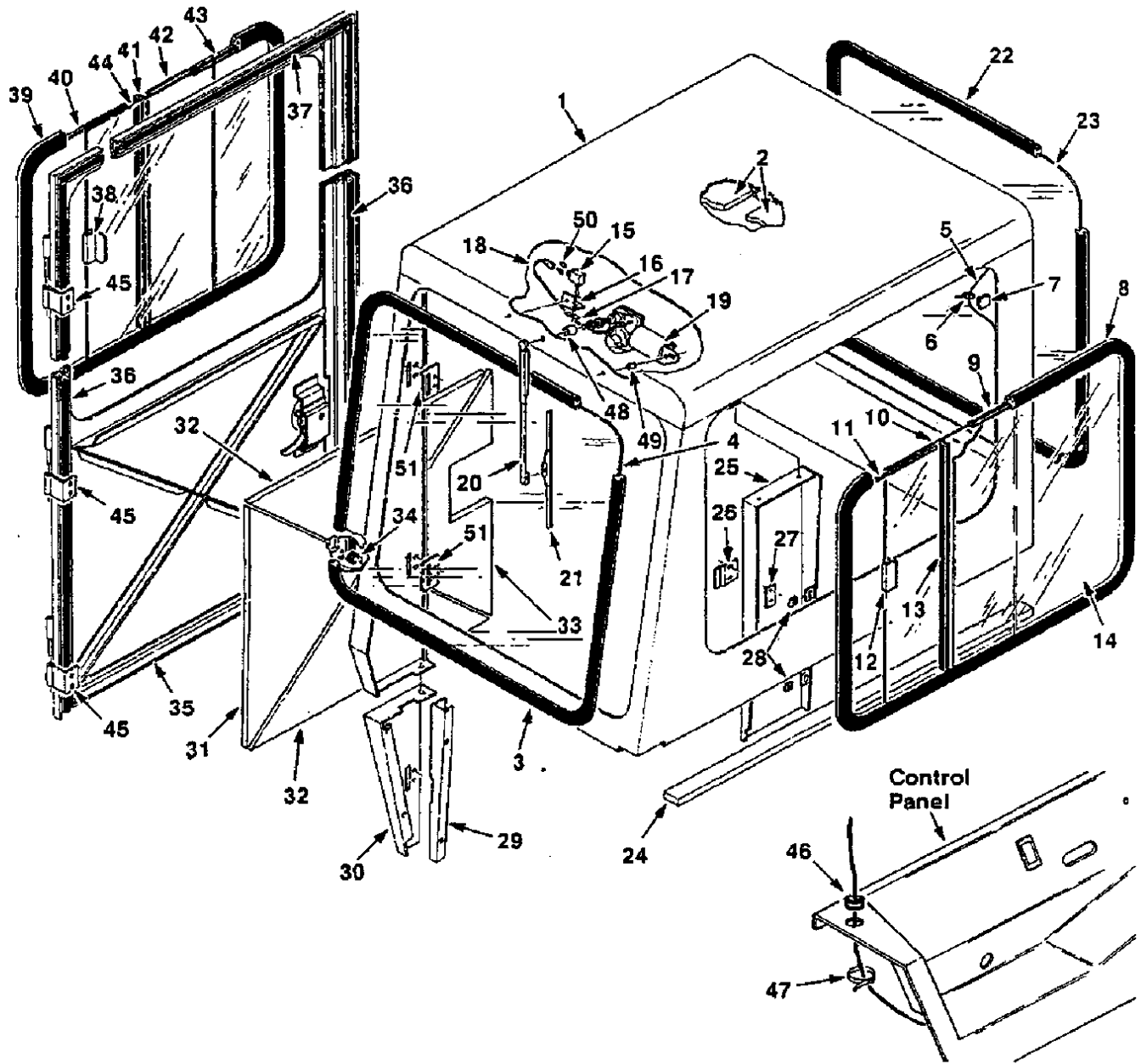

Fig. 1 - Cab Kit

02710

Key	Tennant® Part No.	Machine Serial Number	Description	Qty.
	82914	(000000-)	Cab Kit	1
	82909	(000000- 002968)	Cab Assembly	1
	03253	(002969-)	Cab Assembly	1
1	82900	(000000- 002968)	Cab	1
1	03255	(002969-)	Cab	1
2	55398	(000000-)	Insulation, Foam	2
3	55349	(000000-)	Weather Strip	1
4	55348	(000000- 002968)	Glass, Safety	1
4	03234	(002969-)	Glass, Safety	1
5	03289	(000000- 002711)	Replacement Kit, Wire Harness	1
5	03283	(002712-)	Wire Harness, Cab	1
6	49266	(000000-)	Tie, Cable	2
7	55248	(000000-)	Mount, Cable Tie	2

Key	Tennant® Part No.	Machine Serial Number	Description	Qty.
8	55393	(000000-)	Weather Strip	1
9	55395	(000000-)	Channel, Flexible	1
10	55357	(000000- 002968)	Glass, Safety, Sliding	1
10	12039	(002969-)	Glass, Safety, Sliding	1
11	55369	(000000-)	Spacer, Rubber	1
12	15066	(000000-)	Handle	1
	58974	(000000-)	Pad, Rubber	2
13	55368	(000000-)	Channel, Rigid	1
14	55359	(000000- 002968)	Glass, Safety, Stationary	1
14	03238	(002969-)	Glass, Safety, Stationary	1
15	10701	(000000-)	Switch	1
16	62039	(000000-)	Bracket, L	1
17	07421	(000000-)	Plate, Switch	1
18	55411	(000000- 002711)	Wire, Wiper Motor	1
18	03282	(002712-)	Wire, Wiper Motor	1
19	03296	(000000- 002711)	Replacement Kit, Wiper Motor	1
19	02507	(002712-)	Motor, Wiper	1
20	15121	(000000-)	Arm, Wiper	1
21	23947	(000000-)	Blade, Wiper	1
22	82907	(000000-)	Weather Strip	1
23	82906	(000000- 002968)	Glass, Stationary	1
23	03235	(002969-)	Glass, Stationary	1
24	03247	(002969-)	Seal, Foam Rubber	1
25	82917	(000000-)	Panel, Seat Support	1
26	55429	(000000-)	Strike, Plate	1
27	55431	(000000-)	Plate, Stiffener	1
28	61110	(000000-)	Nut, Retainer	3
29	55321	(000000-)	Channel, Bail	1
30	55322	(000000-)	Panel, Bail	1
	55755	(000000- 002968)	Door Assembly, Cab	1
	03243	(002969-)	Door Assembly, Cab	1
31	55758	(000000-)	Insulation, Foam	1
32	55757	(000000-)	Insulation, Foam	2
33	55759	(000000-)	Insulation, Foam	1
34	82921	(000000-)	Bumper, Rubber	1
35	55750	(000000- 002968)	Door	1
35	03242	(002969-)	Door	1
36	55754	(000000-)	Seal, Side	2
37	55756	(000000-)	Seal, Top	1
38	15066	(000000-)	Handle	1
	58974	(000000-)	Pad, Rubber	2
39	55394	(000000-)	Weather Strip	1
40	55369	(000000-)	Spacer, Rubber	1
41	55368	(000000-)	Channel, Rigid	1
42	55358	(000000- 002968)	Glass, Safety, Stationary	1
42	03237	(002969-)	Glass, Safety, Stationary	1
43	55396	(000000-)	Channel, Flexible	1
44	55357	(000000- 002968)	Glass, Safety, Sliding	1
44	12039	(002969-)	Glass, Safety, Sliding	1
45	55761	(000000-)	Hinge	3
46	10632-2	(000000-)	Grommet	1
47	49266	(000000-)	Tie, Cable	1
48	03280	(002712-)	Spacer	1
49	03281	(002712-)	Spacer	1
50	48252	(002712-)	Tab, Terminal	2
51	55346	(000000-)	Plate, Hinge	2

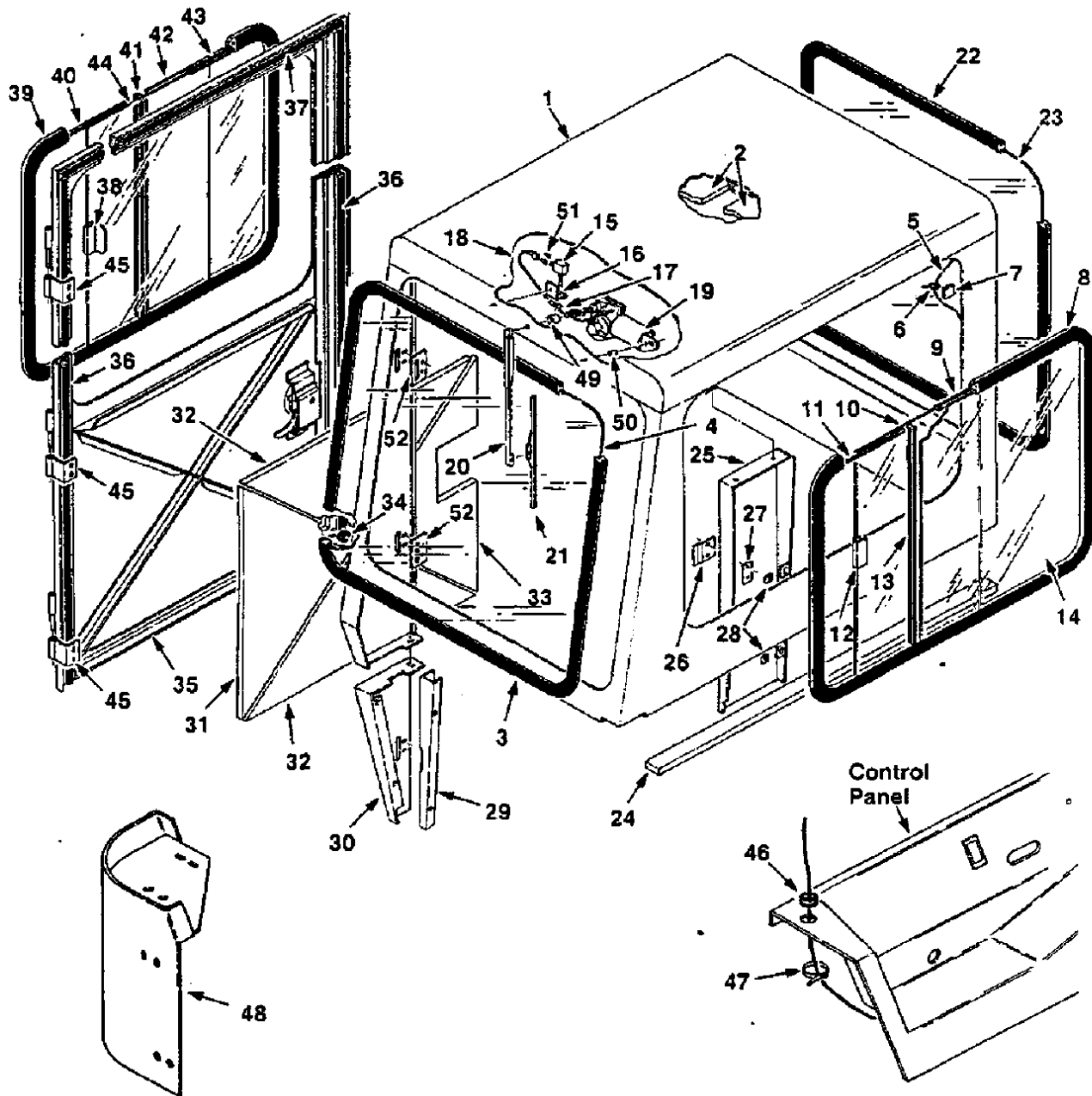

Fig. 2 - Cab Kit, SE

02926

Key	Tennant® Part No.	Machine Serial Number	Description	Qty.
	02914	(000000-)	Cab Kit	1
	82909	(000000- 002968)	Cab Assembly	1
	03253	(002969-)	Cab Assembly	1
1	82900	(000000- 002968)	Cab	1
1	03255	(002969-)	Cab	1
2	55398	(000000-)	Insulation, Foam	2
3	55349	(000000-)	Weather Strip	1
4	55348	(000000- 002968)	Glass, Safety	1
4	03234	(002969-)	Glass, Safety	1
5	03289	(000000- 002711)	Replacement Kit, Wire Harness	1
5	03283	(002712-)	Wire Harness, Cab	1
6	49266	(000000-)	Tie, Cable	2
7	55248	(000000-)	Mount, Cable Tie	2
8	55393	(000000-)	Weather Strip	1

Key	Tennant® Part No.	Machine Serial Number	Description	Qty.
9	55395	(000000-)	Channel, Flexible	1
10	55357	(000000- 002968)	Glass, Safety, Sliding	1
10	12039	(002969-)	Glass, Safety, Sliding	1
11	55369	(000000-)	Spacer, Rubber	1
12	15066	(000000-)	Handle	1
	58974	(000000-)	Pad, Rubber	2
13	55368	(000000-)	Channel, Rigid	1
14	55359	(000000- 002968)	Glass, Safety, Stationary	1
14	03238	(002969-)	Glass, Safety, Stationary	1
15	10701	(000000-)	Switch	1
16	62039	(000000-)	Bracket, L	1
17	07421	(000000-)	Plate, Switch	1
18	55411	(000000- 002711)	Wire, Wiper Motor	1
18	03282	(002712-)	Wire, Wiper Motor	1
19	03296	(000000- 002711)	Replacement Kit, Wiper Motor	1
19	02507	(002712-)	Motor, Wiper	1
20	15121	(000000-)	Arm, Wiper	1
21	23947	(000000-)	Blade, Wiper	1
22	82907	(000000-)	Weather Strip	1
23	82906	(000000- 002968)	Glass, Stationary	1
23	03235	(002969-)	Glass, Stationary	1
24	03247	(002969-)	Seal, Foam Rubber	1
25	82917	(000000-)	Panel, Seat Support	1
26	55429	(000000-)	Strike, Plate	1
27	55431	(000000-)	Plate, Stiffener	1
28	61110	(000000-)	Nut, Retainer	3
29	55321	(000000-)	Channel, Bail	1
30	55322	(000000-)	Panel, Bail	1
	55755	(000000- 002968)	Door Assembly, Cab	1
	03243	(002969-)	Door Assembly, Cab	1
31	55758	(000000-)	Insulation, Foam	1
32	55757	(000000-)	Insulation, Foam	2
33	55759	(000000-)	Insulation, Foam	1
34	82921	(000000-)	Bumper, Rubber	1
35	55750	(000000- 002968)	Door	1
35	03242	(002969-)	Door	1
36	55754	(000000-)	Seal, Side	2
37	55756	(000000-)	Seal, Top	1
38	15066	(000000-)	Handle	1
	58974	(000000-)	Pad, Rubber	2
39	55394	(000000-)	Weather Strip	1
40	55369	(000000-)	Spacer, Rubber	1
41	55368	(000000-)	Channel, Rigid	1
42	55358	(000000- 002968)	Glass, Safety, Stationary	1
42	03237	(002969-)	Glass, Safety, Stationary	1
43	55396	(000000-)	Channel, Flexible	1
44	55357	(000000- 002968)	Glass, Safety, Sliding	1
44	12039	(002969-)	Glass, Safety, Sliding	1
45	55761	(000000-)	Hinge	3
46	10632-2	(000000-)	Grommet	1
47	49266	(000000-)	Tie, Cable	1
48	02945	(000000-)	Tower, Bumper	1
49	03280	(002712-)	Spacer	1
50	03281	(002712-)	Spacer	1
51	48252	(002712-)	Tab, Terminal	2
52	55346	(000000-)	Plate, Hinge	2

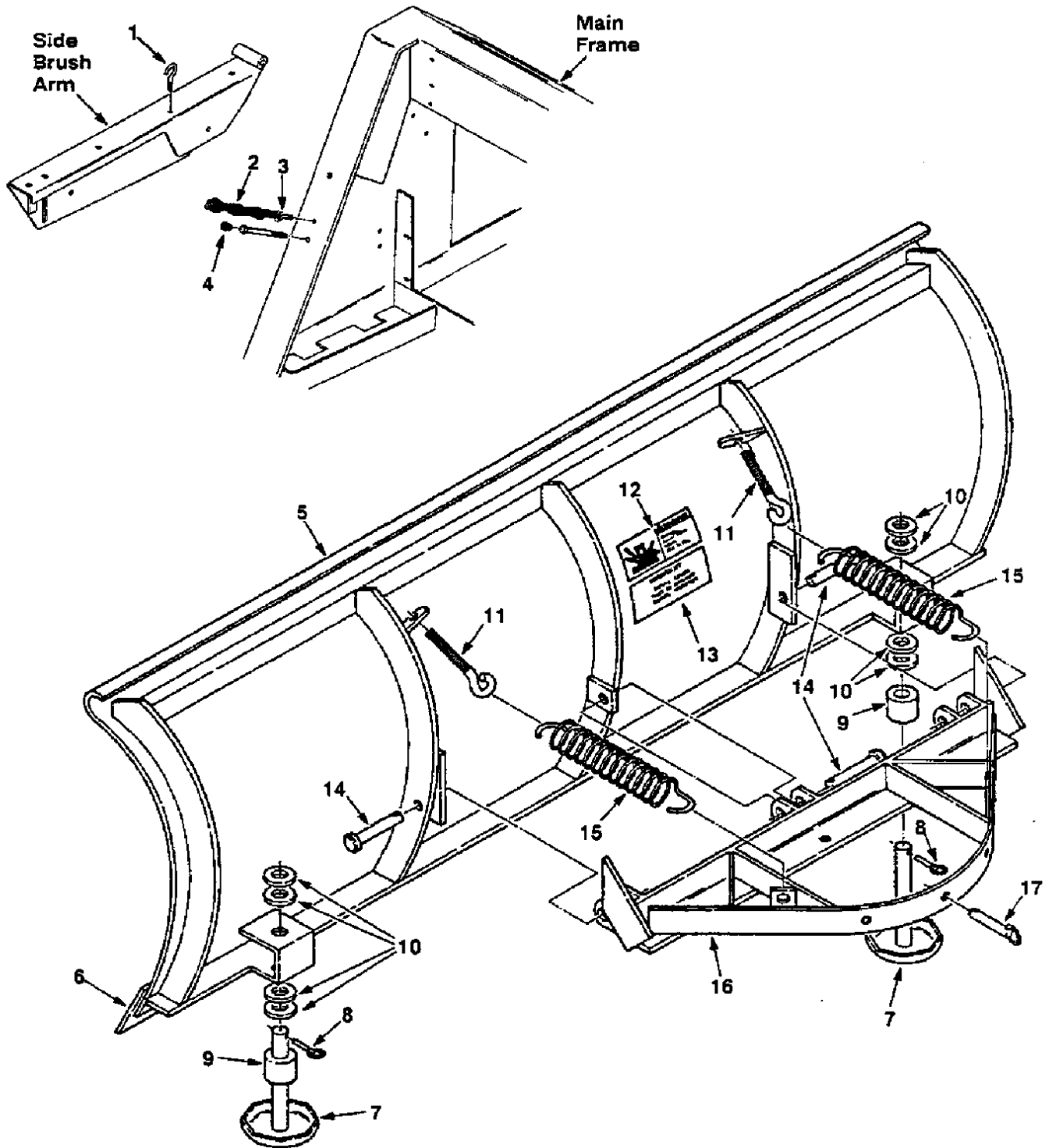

Fig. 3 - Snow Blade Kit

NOTE: To identify parts shown but not listed here, see Section 5, Low Dump Model Parts.

Fig. 3 - Snow Blade Kit

02600

NOTE: Snow Blade Kit, Tennant Part Number 37136, includes Fig. 3, 14, 24, and 43.

Key	Tennant® Part No.	Machine Serial Number	Description	Qty.
	47714	(000000-)	Snow Blade Kit	1
1	21097	(000000-)	Hook, Eyebolt	1
2	47280	(000000-)	Chain Assembly	1
3	11893	(000000-)	Eyebolt	1
4	01318	(000000-)	Tip, Rubber	1
5	31301	(000000-)	Blade Assembly	1
6	08050	(000000-)	Cutting Edge	1
7	08046	(000000-)	Disc Shoe Assembly	2
8	08046	(000000-)	Pin, Linch	2
9	08048	(000000-)	Spacer	2
10	32969	(000000-)	Washer	38
11	47713-2	(000000-)	Eyebolt	2
12	32180	(000000-)	Decal, Hazard	1
13	47477	(000000-)	Decal, Safety Chains	1
14	47713-3	(000000-)	Pin, Clevis	3
15	47713-1	(000000-)	Spring	2
16	31302	(000000-)	Quadrant Assembly	1
17	47715	(000000-)	Pin, Quick Release	1

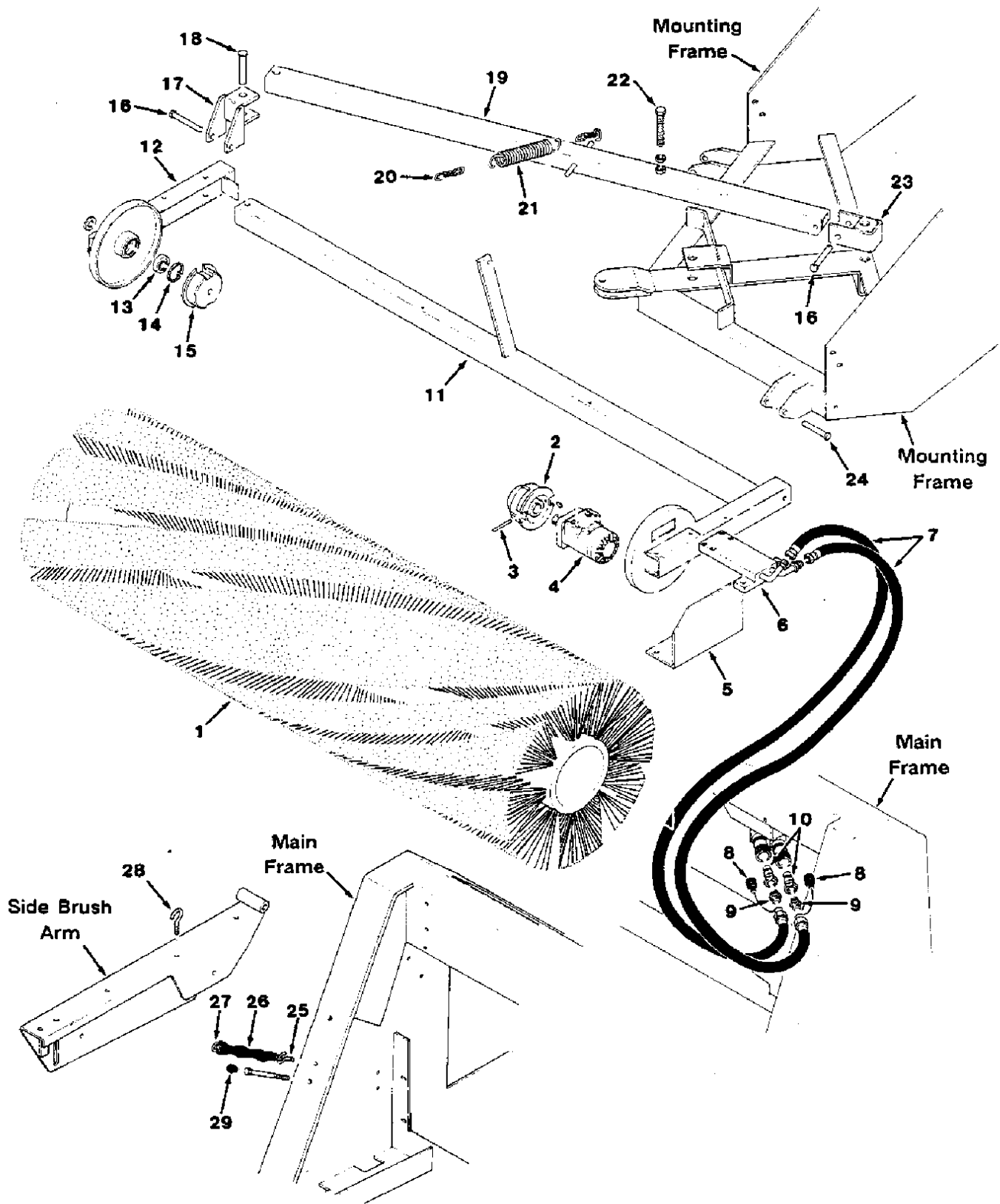

Fig. 4 - Snow Broom Kit

NOTE: To identify parts shown but not listed here, see Section 5, Low Dump Model Parts.

Fig. 4 - Snow Broom Kit

02743

NOTE: Snow Broom Kit, Tennant Part Number 02629, includes Fig. 4, 14, 24, and 43.

Key	Tennant® Part No.	Machine Serial Number	Description	Qty.
	82082	(000000-)	Broom Kit, Snow	1
1	24741	(000000-)	Broom	1
2	24743	(000000-)	Plug, Drive	1
3	11516	(000000-)	Pin, Roll	1
4	47650-9	(000000-)	Motor, Hydraulic	1
5	32162	(000000-)	Bracket, Bumper	1
6	82079	(000000-)	Block, Porting	1
7	82081	(000000-)	Hose, Hydraulic	2
8	33862	(000000-)	Cap, Dust	2
9	44869	(000000-)	Fitting, Straight	2
10	65084-1	(000000-)	Fitting, Coupling, Male	2
11	24705	(000000-)	Frame, Broom	1
12	24704	(000000-)	Frame, Broom, R.H.	1
13	46390	(000000-)	Bearing, Ball	1
14	10464	(000000-)	Ring, Retaining	1
15	07037	(000000-)	Plug, Brush	1
16	06474A	(000000-)	Pin, Clevis	2
17	24724	(000000-)	Yoke	1
18	24729	(000000-)	Pin, Clevis	1
19	24737	(000000-)	Arm, Broom Support	1
20	24769	(000000-)	Chain, Coil	1
21	24776	(000000-)	Spring, Tension	1
22	41177	(000000-)	Screw, Hex	1
23	24721	(000000-)	Pivot, End, Bracket	1
24	23191	(000000-)	Pin, Clevis	1
25	11893	(000000-)	Bolt, Eye	1
26	46567	(000000-)	Hose, Rubber	1
27	40758	(000000-)	Chain, Link	1
28	21097	(000000-)	Hook	1
29	01318	(000000-)	Tip, Rubber	1
	24787	(000000-)	Decal, Warning, Windrow Broom	1

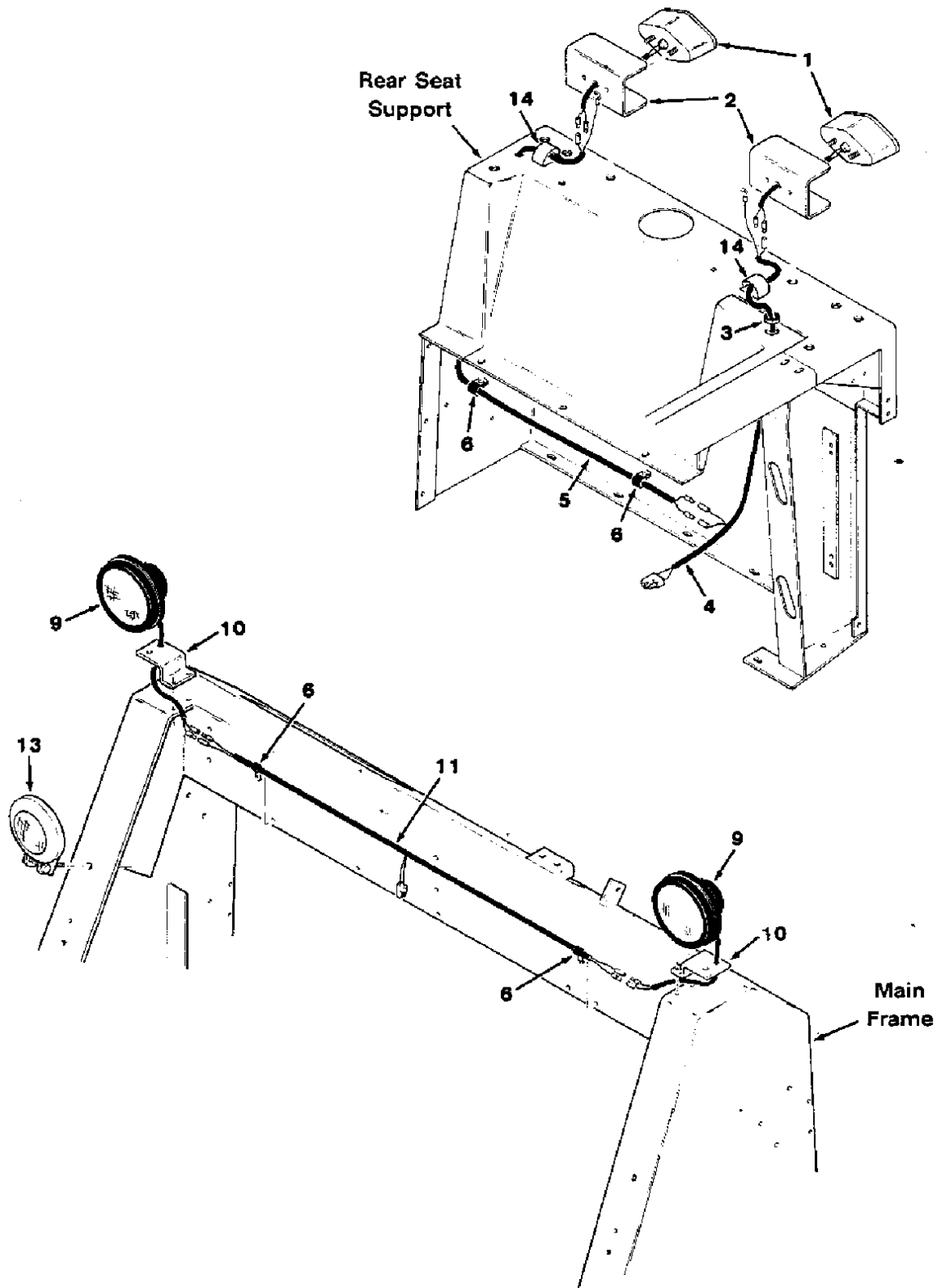

Fig. 5 - Headlight, Taillight, and Spotlight Kit, Lintel

NOTE: To identify parts shown but not listed here, see Section 5, Low Dump Model Parts.

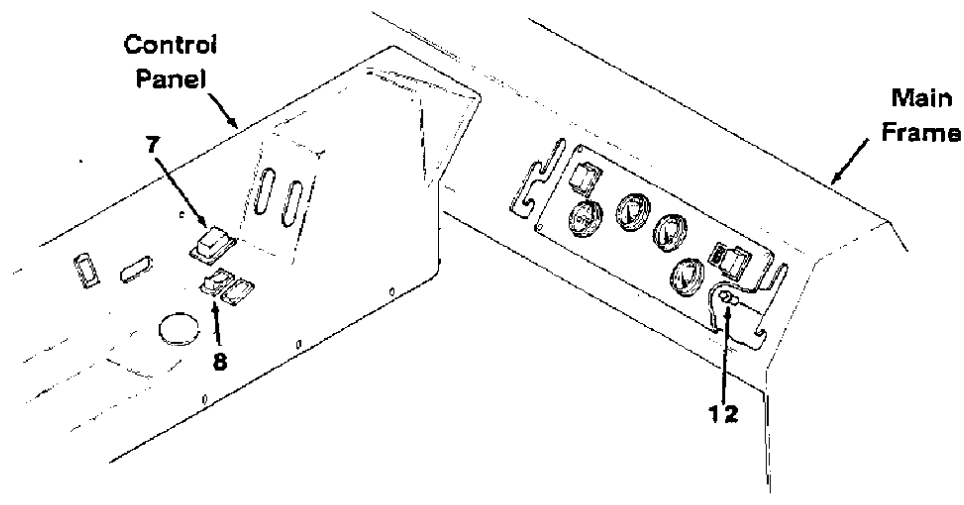

Fig. 5 - Headlight, Taillight, and Spotlight Kit, Lintel

02933

Key	Tennant® Part No.	Machine Serial Number	Description	Qty.
1	02893	(000000-)	Light Kit, Headlight, Taillight and Spotlight	1
	55274	(000000-)	Taillight	2
	45780	(000000-)	Bulb	1
	82725	(000000-)	Guard, Light	2
3	10632-2	(000000-)	Grommet	1
4	82707	(000000-)	Wire Harness, L.H.	1
5	82735	(000000-)	Wire Harness, R.H.	1
6	40678	(000000-)	Clamp, Cable	5
7	57807	(000000-)	Seal, Switch	1
8	81458	(000000-)	Switch, Rocker	1
9	02897	(000000-)	Headlight	2
	51570	(000000-)	Lamp	1
10	02896	(000000-)	Bracket, Light	2
11	02894	(000000-)	Wire Harness, Headlight	1
12	55271	(000000-)	Light, Instrument	4
13	82595	(000000-)	Spotlight Assembly	1
	32827	(000000-)	Bulb	1
14	82637	(000000-)	Clamp, Cable	2
	55272	(000000-)	Terminal, Snap Plug	2
	49266	(000000-)	Tie, Cable	5
	55248	(000000-)	Mount, Cable Tie	1

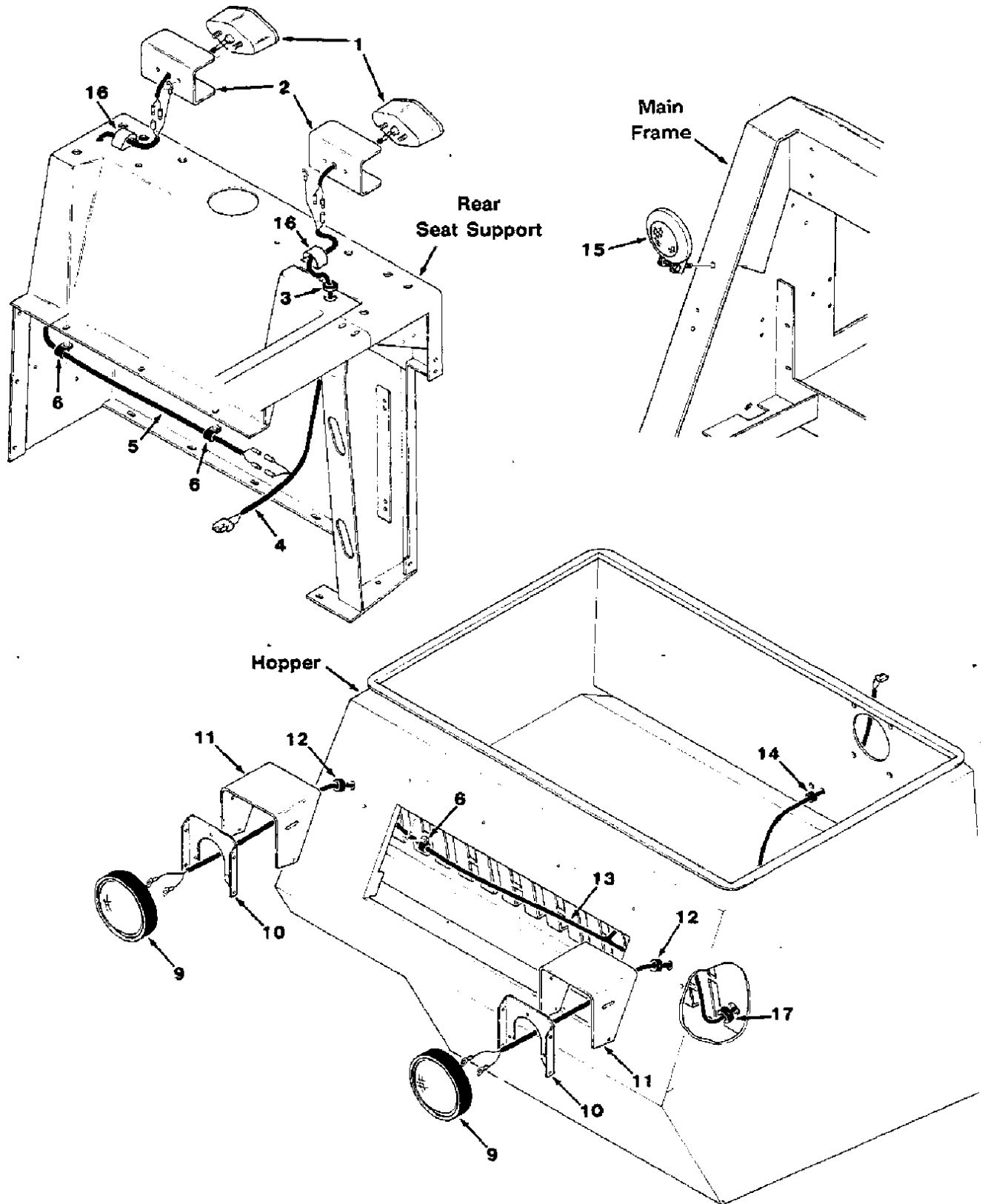

Fig. 6 - Headlight, Taillight, and Spotlight Kit, Low Dump

NOTE: To identify parts shown but not listed here, see Section 5, Low Dump Model Parts.

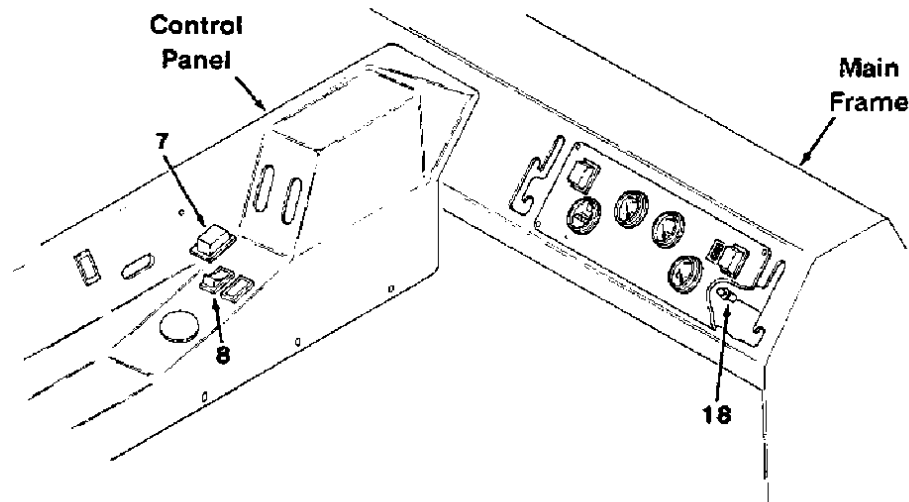

Fig. 6 - Headlight, Taillight, and Spotlight Kit, Low Dump

02604

Key	Tennant® Part No.	Machine Serial Number	Description	Qty.
1	82990	(000000-)	Light Kit, Headlight, Taillight and Spotlight	1
	55274	(000000-)	Taillight	2
	45780	(000000-)	Bulb	1
2	82725	(000000-)	Guard, Light	2
3	10632-2	(000000-)	Grommet	1
4	82707	(000000-)	Wire Harness, L.H.	1
5	82735	(000000-)	Wire Harness, R.H.	1
6	40678	(000000-)	Clamp, Cable	5
7	57807	(000000-)	Seal, Switch	1
8	81458	(000000-)	Switch, Rocker	1
9	46108	(000000-)	Headlight	2
	10801	(000000-)	Lamp	1
10	46110	(000000-)	Plate, Headlight	2
11	51665	(000000-)	Wrap, Headlight	2
12	10632-5	(000000-)	Grommet	2
13	82706	(000000-)	Wire Harness, Headlight	1
14	47591	(000000-)	Strain Relief	1
15	82595	(000000-)	Spotlight Assembly	1
	32827	(000000-)	Bulb	1
16	82637	(000000-)	Clamp, Cable	2
17	10632-4	(000000-)	Grommet	1
18	55271	(000000-)	Light, Instrument	4
	55272	(000000-)	Terminal, Snap Plug	2
	49266	(000000-)	Tie, Cable	5
	55248	(000000-)	Mount, Cable Tie	1

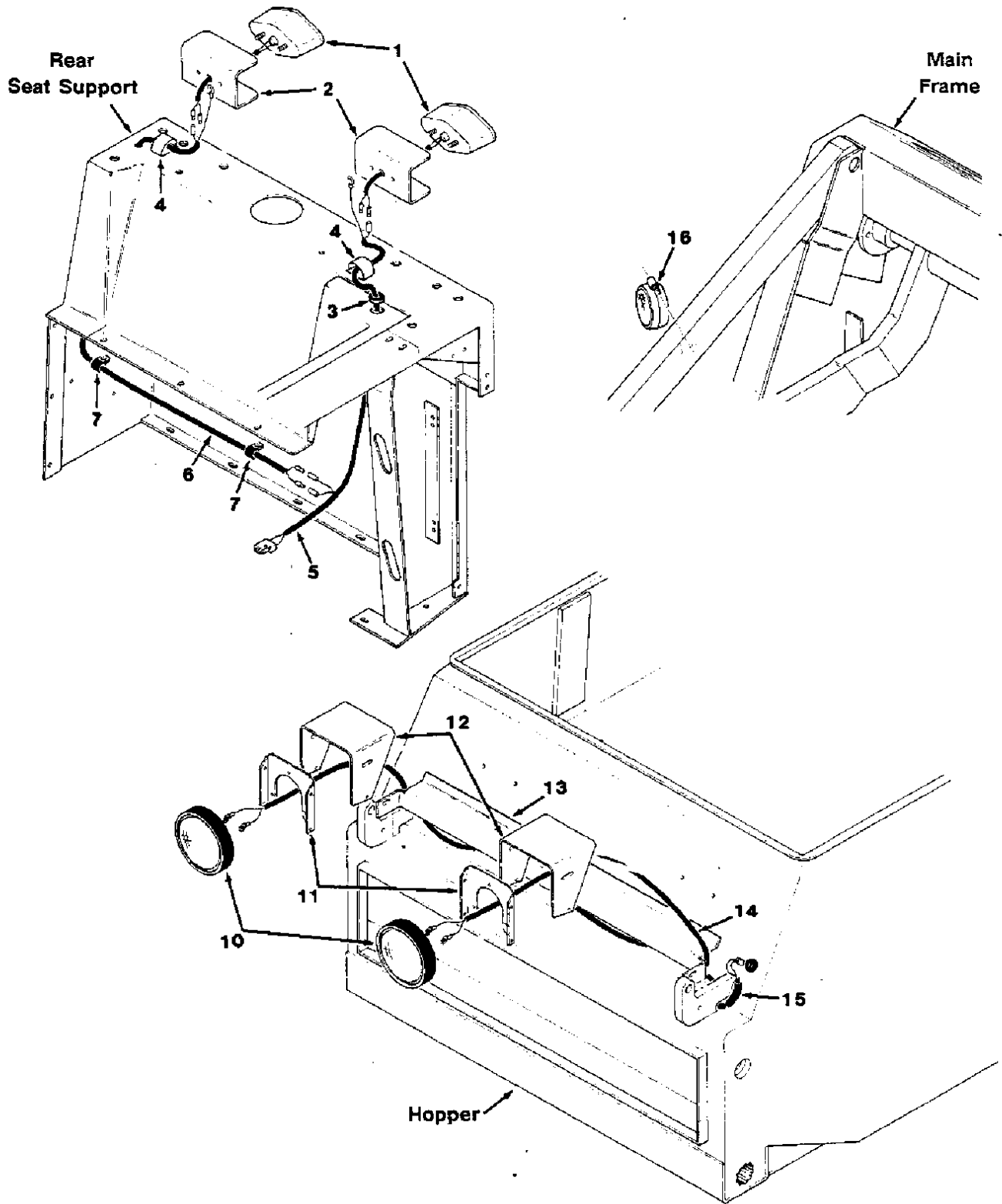

Fig. 7 - Headlight, Taillight, and Spotlight Kit, Multi-level Dump

NOTE: To identify parts shown but not listed here, see Section 5, Low Dump Model Parts, or Section 8, Multi-level Dump Model Parts.

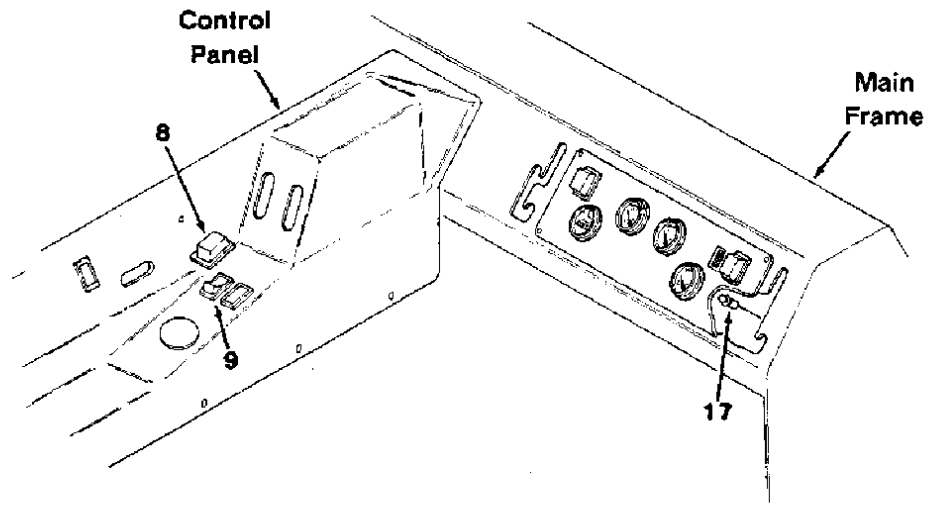

Fig. 7 - Headlight, Taillight, and Spotlight Kit, Multi-level Dump

02792

Key	Tennant® Part No.	Machine Serial Number	Description	Qty.
1	82636	(000000-)	Light Kit, Headlight, Taillight, and Spotlight	1
	55274	(000000-)	Taillight	2
	45780	(000000-)	Bulb	1
2	82725	(000000-)	Guard, Light	2
3	10632-2	(000000-)	Grommet	1
4	82637	(000000-)	Clamp, Cable	2
5	82707	(000000-)	Wire Harness, L.H.	1
6	82735	(000000-)	Wire Harness, R.H.	1
7	40678	(000000-)	Cable, Clamp	3
8	57807	(000000-)	Seal, Switch	1
9	81458	(000000-)	Switch, Rocker	1
10	46108	(000000-)	Headlight	2
	10801	(000000-)	Lamp	1
11	46110	(000000-)	Plate, Headlight	2
12	51665	(000000-)	Wrap, Headlight	2
13	82736	(000000-)	Cover, Harness	1
14	82645	(000000-)	Wire Harness, Headlight	1
15	76207	(000000-)	Tube, Heat Shrink	1
16	82587	(000000-)	Spotlight Assembly	1
	32827	(000000-)	Bulb	1
17	55271	(000000-)	Light, Instrument	4
	55272	(000000-)	Terminal, Snap Plug	2
	49266	(000000-)	Tie, Cable	6
	55248	(000000-)	Mount, Cable Tie	2

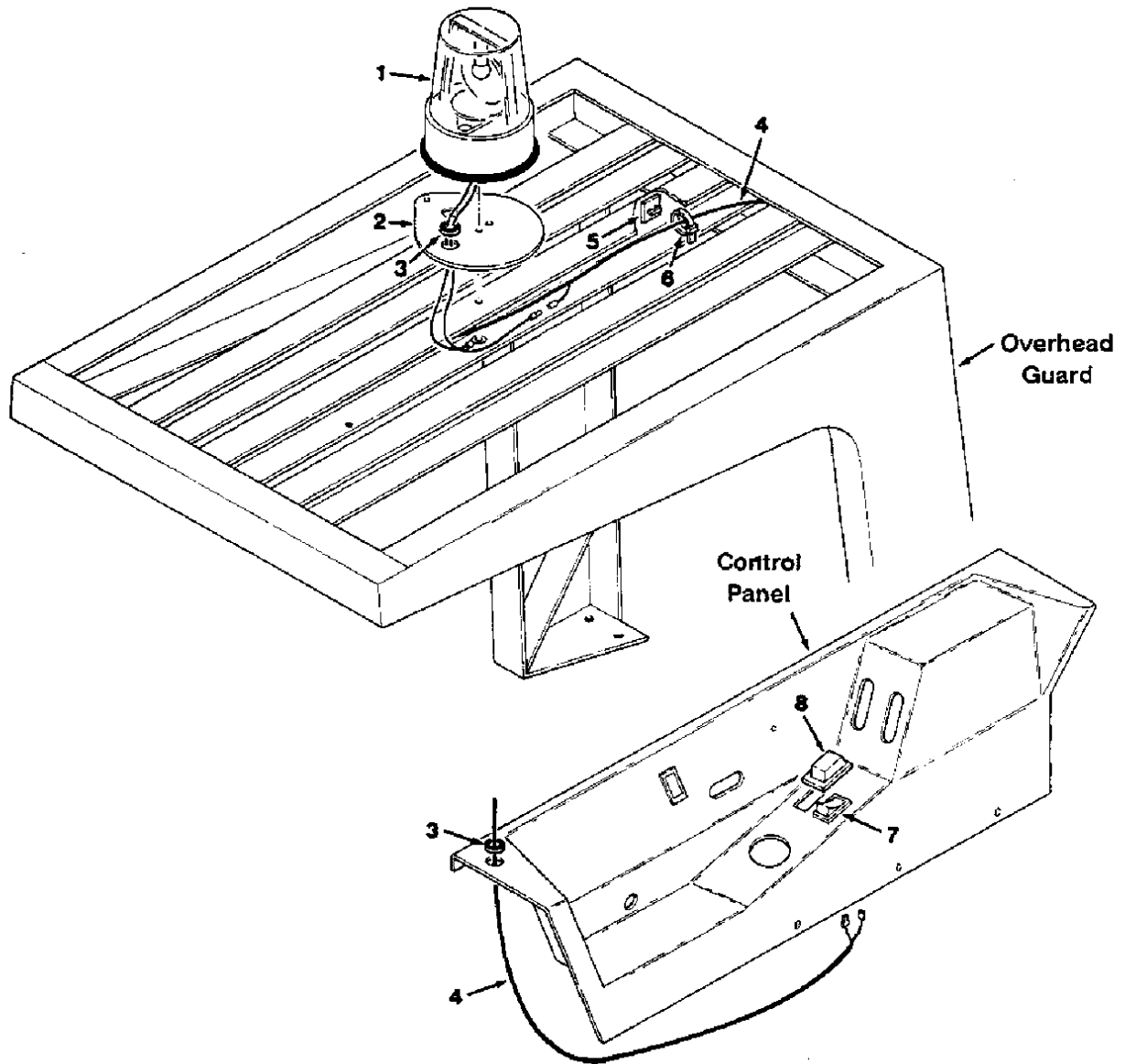

Fig. 8 - Revolving Light Kit, Overhead Guard

02605

Key	Tennant® Part No.	Machine Serial Number	Description	Qty.
1	82066	(000000-)	Light Kit, Revolving, Amber	1
	82200	(000000-)	Light Assembly, Revolving	1
	45779	(000000-)	Bulb	1
	44681-1	(000000-)	Lens, Amber	1
	57220	(000000-)	Plate, Mounting	1
3	10632-2	(000000-)	Grommet	2
4	82734	(000000-)	Wire Harness	1
5	55248	(000000-)	Mount, Cable Tie	8
6	49266	(000000-)	Tie, Cable	9
7	81458	(000000-)	Switch, Rocker	1
8	57807	(000000-)	Seal, Switch	1
	44681	(000000-)	Lens, Red	1
	44681-2	(000000-)	Lens, Blue	1

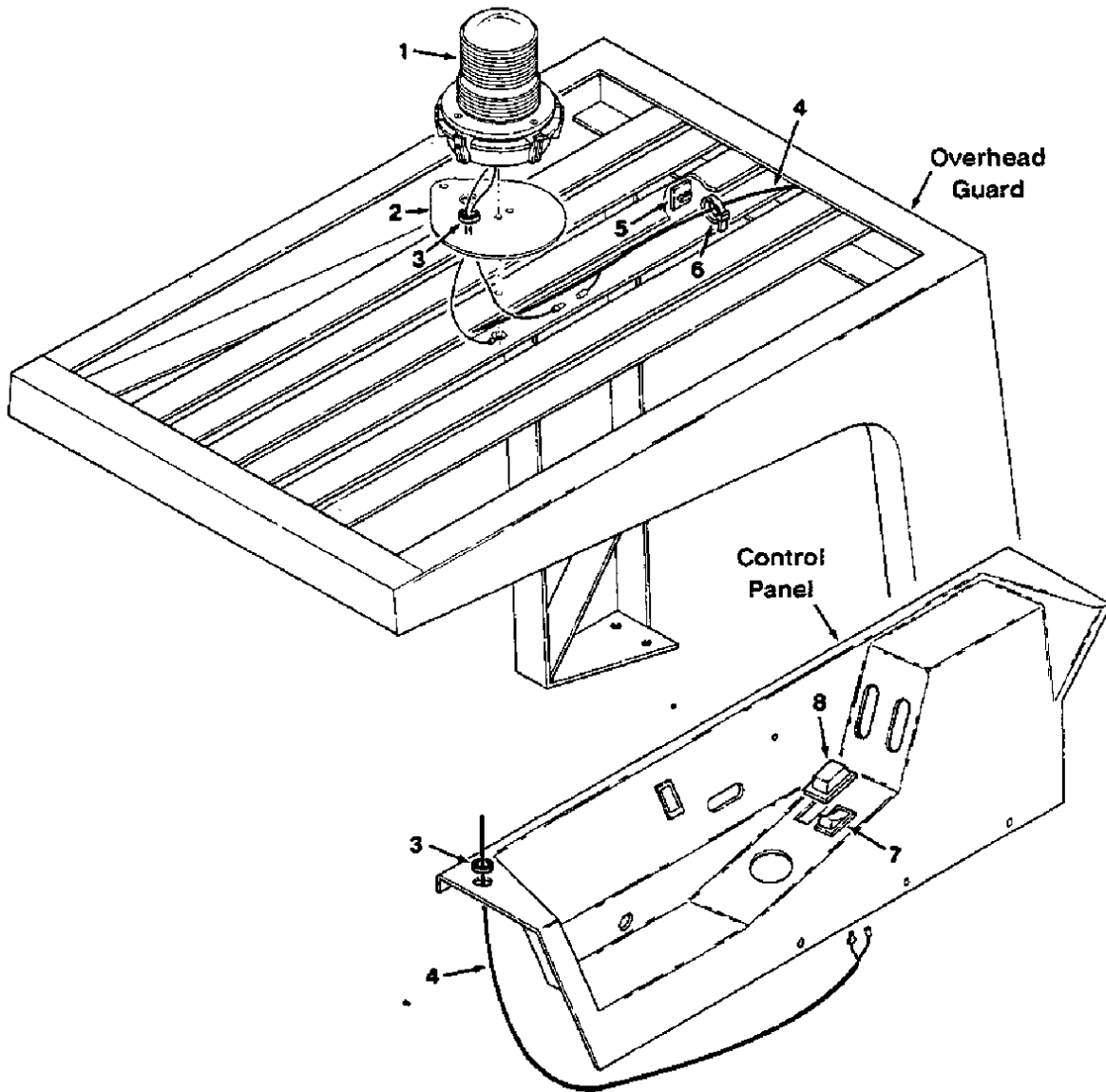

Fig. 9 - Flashing Light Kit, Overhead Guard

02606

Key	Tennant® Part No.	Machine Serial Number	Description	Qty.
1	82072	(000000-)	Light Kit, Flashing, Amber	1
	82063	(000000-)	Light Assembly, Flashing	1
	58520	(000000-)	Lens, Light, Amber	1
	45779	(000000-)	Bulb	1
2	57220	(000000-)	Plate	1
3	10632-2	(000000-)	Grommet	2
4	82734	(000000-)	Wire Harness	1
5	55248	(000000-)	Mount, Cable Tie	8
6	49266	(000000-)	Tie, Cable	9
7	81458	(000000-)	Switch, Rocker	1
8	57807	(000000-)	Seal, Switch	1
	58518	(000000-)	Lens, Red	1
	58519	(000000-)	Lens, Blue	1

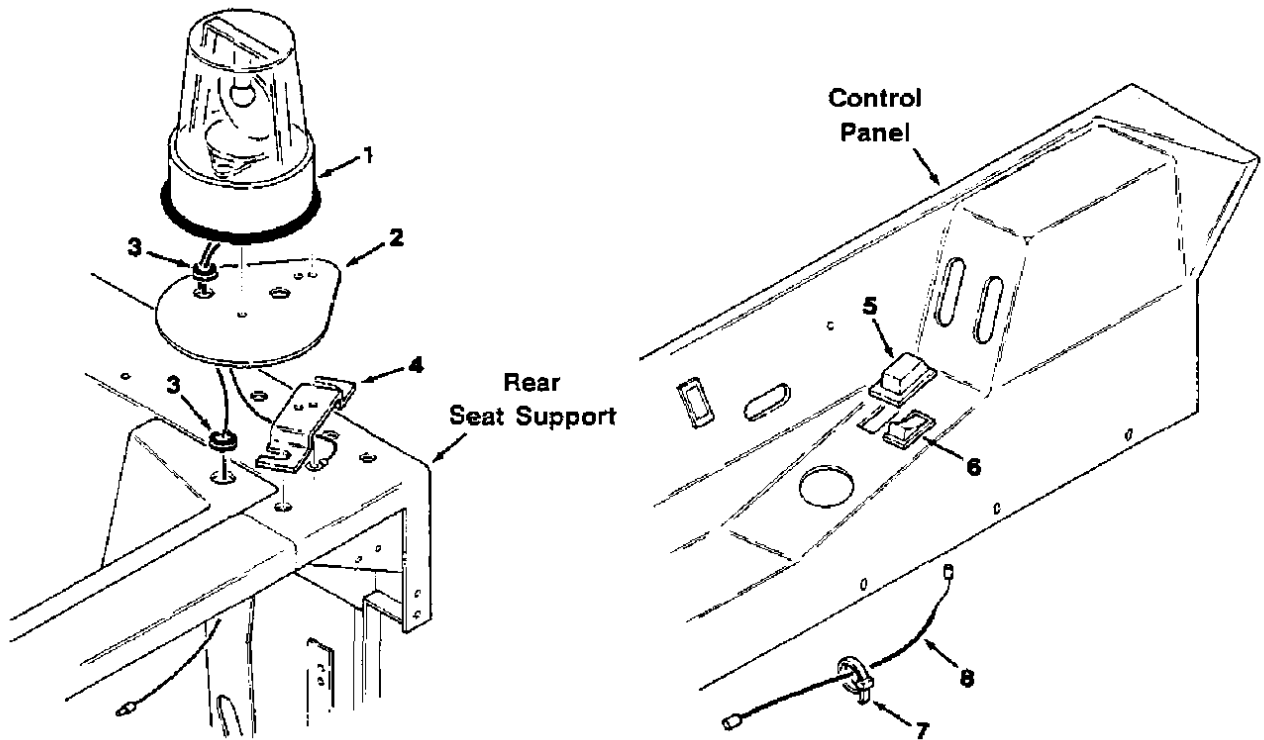

Fig. 10 - Revolving Light Kit, Shroud

02618

Key	Tennant® Part No.	Machine Serial Number	Description	Qty.
1	82064	(000000-)	Light Kit, Revolving, Amber	1
	82200	(000000-)	Light Assembly, Revolving	1
	45779	(000000-)	Bulb	1
	44681-1	(000000-)	Lens, Amber	1
2	57220	(000000-)	Plate, Mounting	1
3	10632-2	(000000-)	Grommet	2
4	82738	(000000-)	Bracket, Mounting	1
5	57807	(000000-)	Seal, Switch	1
6	81458	(000000-)	Switch, Rocker	1
7	49266	(000000-)	Tie, Cable	1
8	82062	(000000-)	Wire Harness	1
	44681	(000000-)	Lens, Red	1
	44681-2	(000000-)	Lens, Blue	1

NOTE: To identify parts shown but not listed here, see Section 5, Low Dump Model Parts.

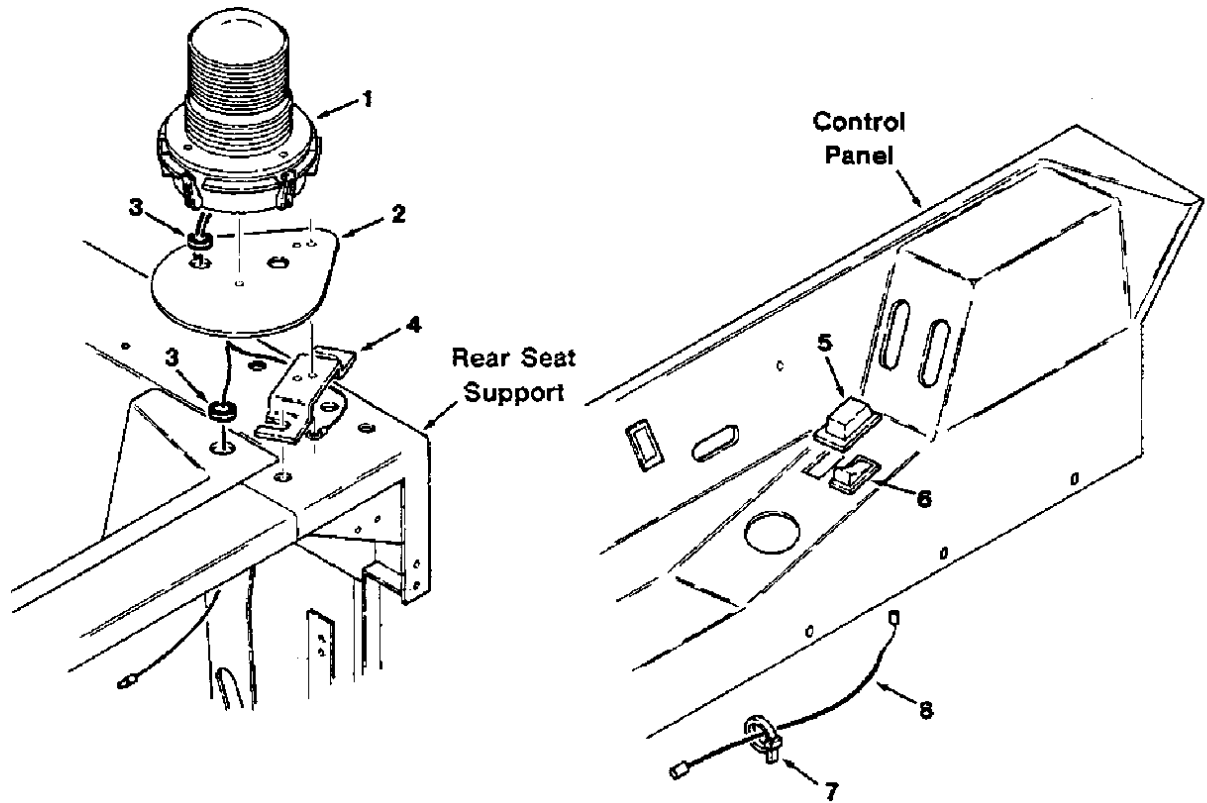

Fig. 11 - Flashing Light Kit, Shroud

02619

Key	Tennant® Part No.	Machine Serial Number	Description	Qty.
1	82070	(000000-)	Light Kit, Flashing, Amber	1
	82063	(000000-)	Light Assembly, Flashing	1
	58520	(000000-)	Lens, Light, Amber	1
	45779	(000000-)	Bulb	1
2	57220	(000000-)	Plate, Mounting	1
3	10632-2	(000000-)	Grommet	2
4	82738	(000000-)	Bracket, Mounting	1
5	57807	(000000-)	Seal, Switch	1
6	81458	(000000-)	Switch, Rocker	1
7	49266	(000000-)	Tie, Cable	1
8	82062	(000000-)	Wire Harness	1
	58518	(000000-)	Lens, Red	1
	58519	(000000-)	Lens, Blue	1

NOTE: To identify parts shown but not listed here, see Section 5, Low Dump Model Parts.

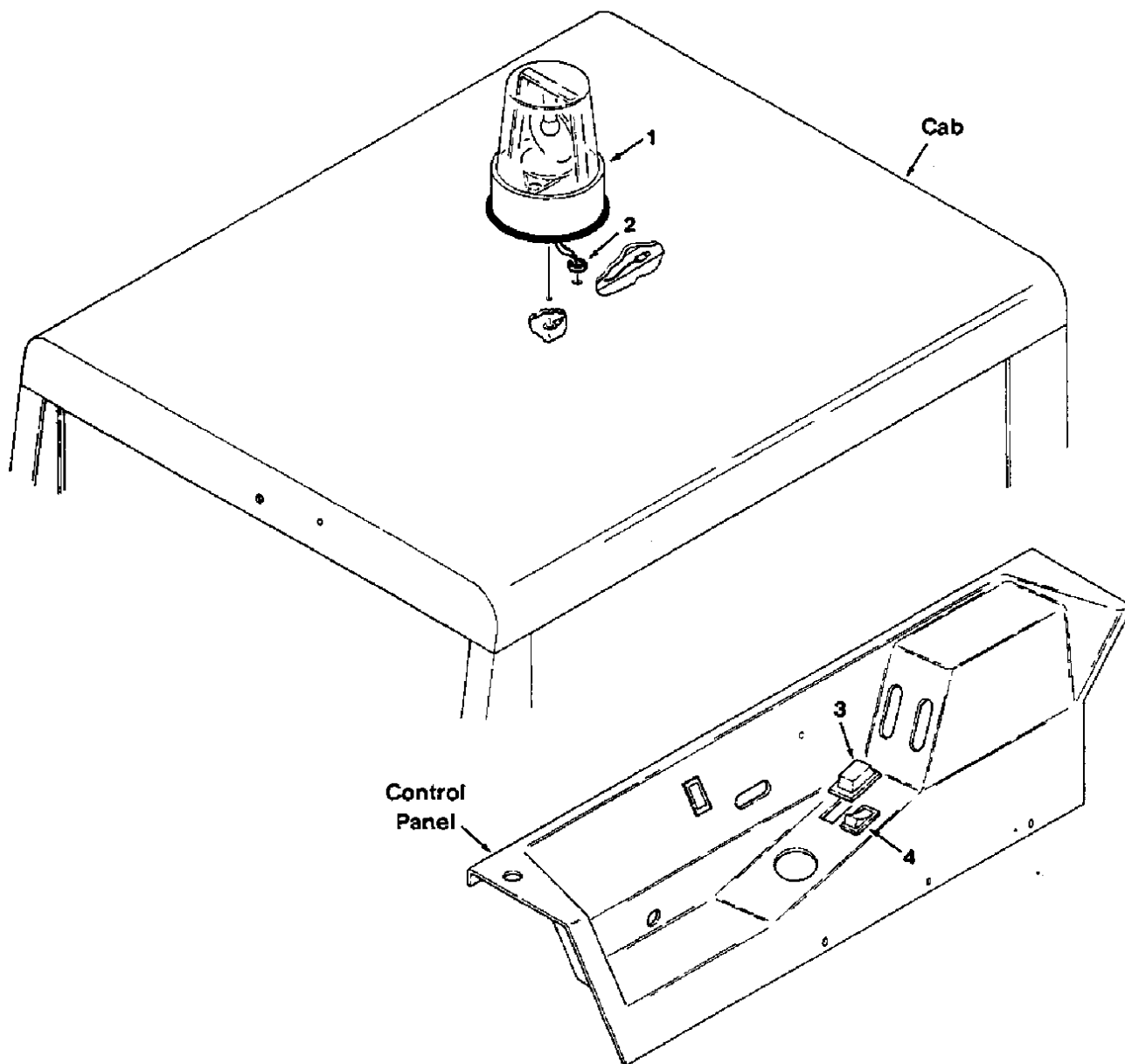

Fig. 12 - Revolving Light Kit, Cab

02620

Key	Tennant® Part No.	Machine Serial Number	Description	Qty.
1	82068	(000000-)	Light Kit, Revolving, Amber	1
	82200	(000000-)	Light Assembly, Revolving	1
	45779	(000000-)	Bulb	1
	44681-1	(000000-)	Lens, Amber	1
2	10632-20	(000000-)	Grommet	1
3	57807	(000000-)	Seal, Switch	1
4	81458	(000000-)	Switch, Rocker	1
	44681	(000000-)	Lens, Red	1
	44681-2	(000000-)	Lens, Blue	1

NOTE: To identify parts shown but not listed here, see Section 5, Low Dump Model Parts.

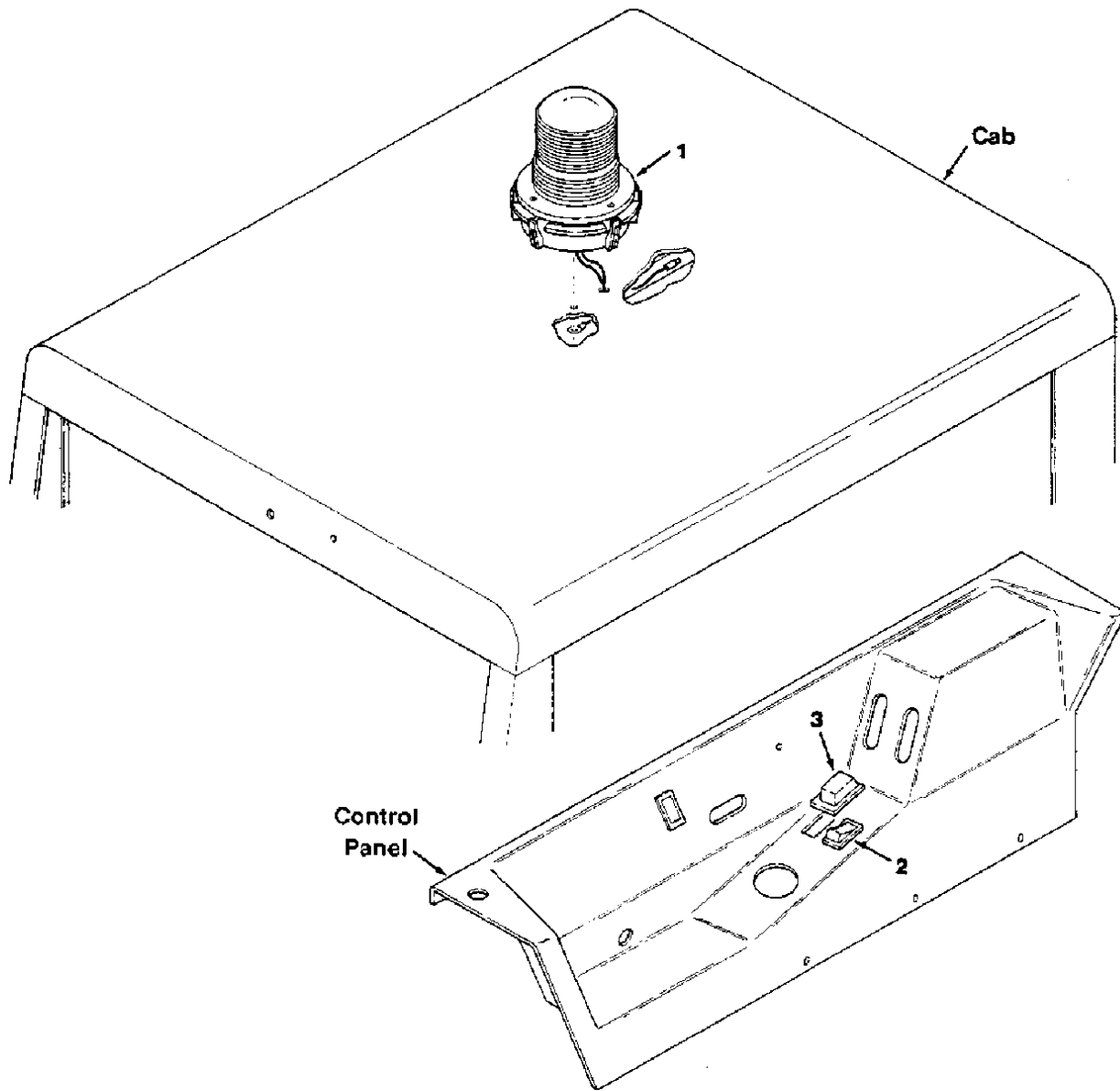

Fig. 13 - Flashing Light Kit, Cab

Key	Tennant® Part No.	Machine Serial Number	Description	Qty.
1	82074	(000000-)	Light Kit, Flashing, Amber	1
	82063	(000000-)	Light Assembly, Flashing	1
	58520	(000000-)	Lens, Light, Amber	1
	45779	(000000-)	Bulb	1
2	81458	(000000-)	Switch, Rocker	1
3	57807	(000000-)	Seal, Switch	1
	08317	(000000-)	Sealant, Silastic	1
	58518	(000000-)	Lens, Red	1
	58519	(000000-)	Lens, Blue	1

NOTE: To identify parts shown but not listed here, see Section 5, Low Dump Model Parts.

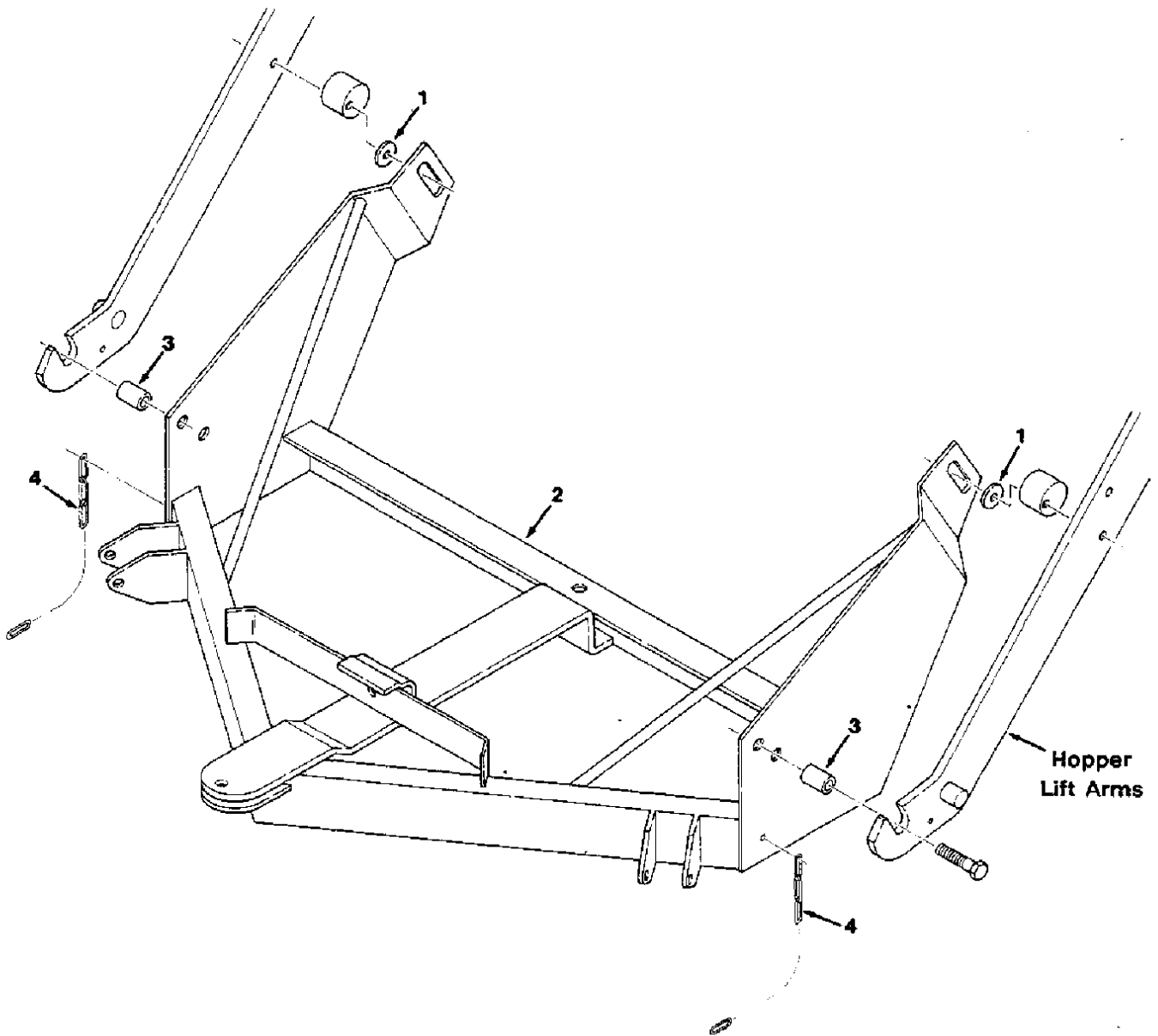

Fig. 14 - Mount Frame Kit

*NOTE: Snow Broom Kit, Tennant Part Number 02629, includes Fig. 4, 14, 24, and 43.
Snow Blade Kit, Tennant Part Number 37136, includes Fig. 3, 14, 24, and 43.*

02586

Key	Tennant® Part No.	Machine Serial Number	Description	Qty.
	24767	(000000-)	Frame Kit, Mount	1
1	07027	(000000-)	Sleeve	2
2	24706	(000000-)	Frame, Mounting	1
3	24728	(000000-)	Sleeve	2
4	32321	(000000-)	Chain, Coil	2

NOTE: To identify parts shown but not listed here, see Section 5, Low Dump Model Parts.

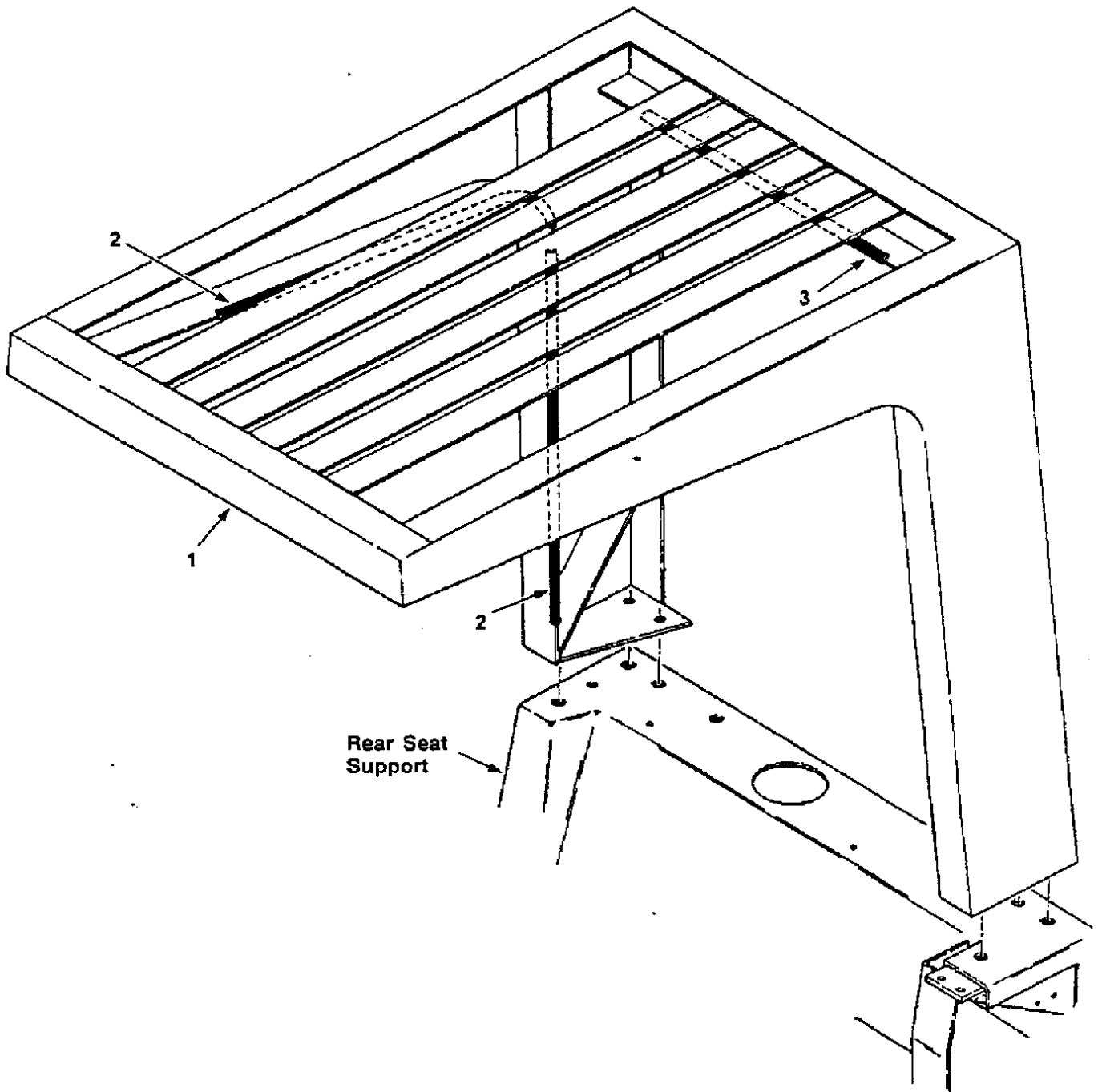

Fig. 15 - Overhead Guard Kit

04613

Key	Tennant® Part No.	Machine Serial Number	Description	Qty.
	82998	(000000-)	Guard Kit, Overhead	1
1	55150	(000000-)	Guard, Overhead	1
2	62595-11	(003417-)	Rigid Molding	2
3	62595-2	(003417-)	Rigid Molding	1

NOTE: To identify parts shown but not listed here, see Section 5, Low Dump Model Parts.

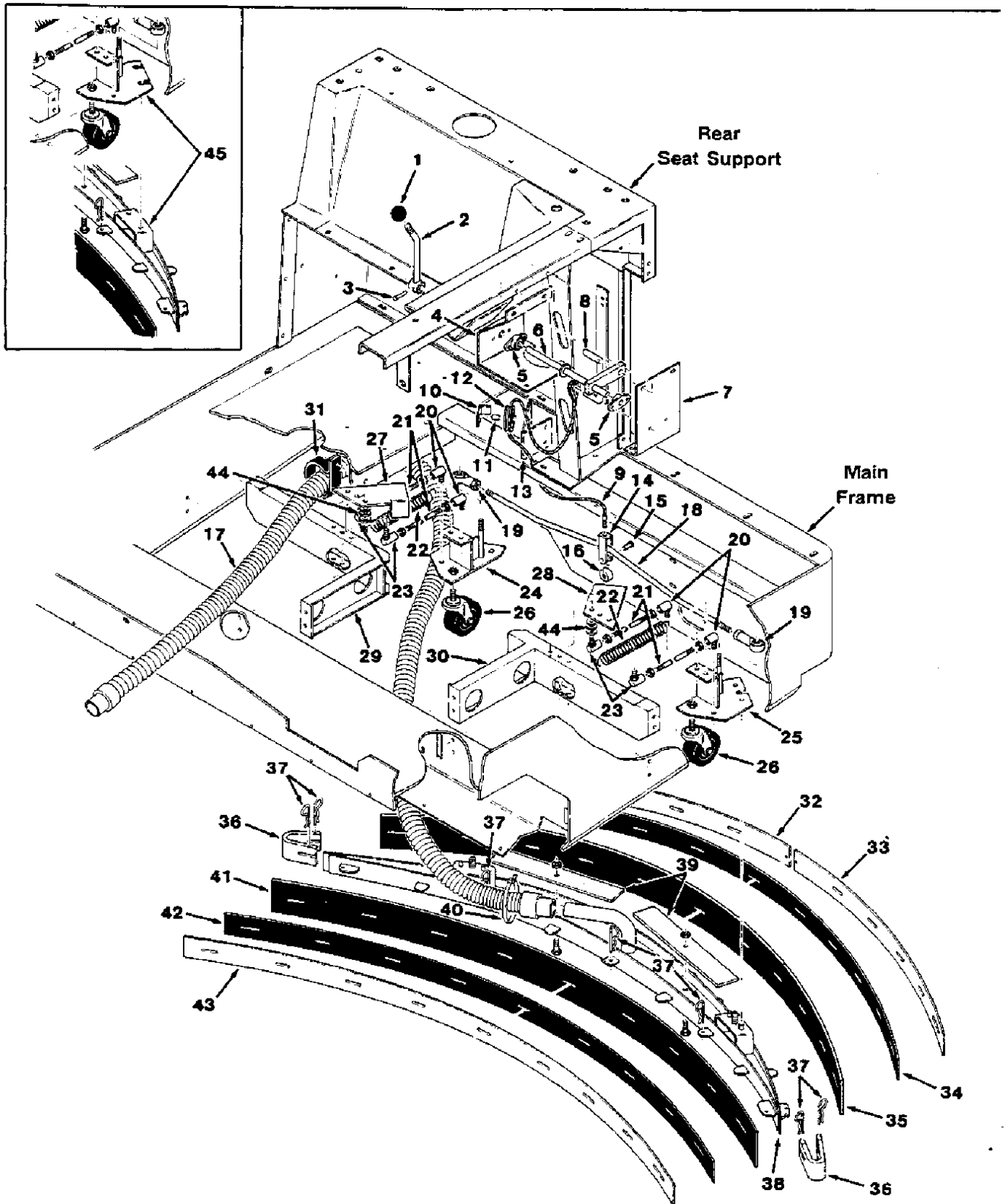

Fig. 16 - Rear Squeegee Group

NOTE: To identify parts shown but not listed here, see Section 5, Low Dump Model Parts.

Fig. 16 - Rear Squeegee Group

03448

NOTE: Squeegees and Control Kit, Tennant Part Number 02948, includes Fig. 16, 18, 19, 24, and 28.
Squeegees and Control Kit, SE, Tennant Part Number 82091, includes Fig. 16, 18, 20, 24, and 28.

Key	Tennant® Part No.	Machine Serial Number	Description	Qty.
1	26156	(000000-xxxxxx)	Knob	1
2	82856	(000000-xxxxxx)	Handle, Lift	1
3	50498	(000000-xxxxxx)	Pin, Clevis	1
4	82851	(000000-xxxxxx)	Support, Lift Handle	1
5	47585	(000000-xxxxxx)	Bearing, Flange	2
6	02953	(000000-xxxxxx)	Rod, Lift	1
7	02954	(000000-xxxxxx)	Plate, Support	1
8	02951	(000000-xxxxxx)	Link, Squeegee Lift	1
9	02959	(000000-xxxxxx)	Cable, Lift	1
10	36077	(000000-xxxxxx)	Bracket, L	1
11	53051A	(000000-xxxxxx)	Spacer	1
12	58279	(000000-xxxxxx)	Pulley, Cable	1
13	82861	(000000-xxxxxx)	Bracket, Pulley Lift	1
14	82855	(000000-xxxxxx)	Yoke, Cable Lift	1
15	51727	(000000-xxxxxx)	Pin, Clevis	1
16	63878	(000000-xxxxxx)	Roller	1
17	43209	(000000-xxxxxx)	Hose and Cuff Assembly	1
18	82944	(000000-xxxxxx)	Tie Rod	1
19	67555	(000000-xxxxxx)	Ball Joint	2
20	82962	(000000-xxxxxx)	Ball Joint	4
21	03093	(000000-xxxxxx)	Rod, Linkage	4
22	47745	(000000-xxxxxx)	Spring, Tension	2
23	51531	(000000-xxxxxx)	Ball Joint	4
24	82974	(000000-002496)	Bracket, Squeegee Link, R.H.	1
24	03090	(002497-xxxxxx)	Bracket, Squeegee Link, R.H.	1
25	82973	(000000-002496)	Bracket, Squeegee Link, L.H.	1
25	03086	(002497-xxxxxx)	Bracket, Squeegee Link, L.H.	1
26	75977	(000000-xxxxxx)	Caster, Swivel	2
27	02919	(000000-xxxxxx)	Bracket, Squeegee Stop, R.H.	1
28	02941	(000000-xxxxxx)	Bracket, Squeegee Stop, L.H.	1
29	82965	(000000-xxxxxx)	Mount, Squeegee Link, R.H.	1
30	82966	(000000-xxxxxx)	Mount, Squeegee Link, L.H.	1
31	47795-1	(000000-xxxxxx)	Strap, Rubber	1
32	04175	(000000-xxxxxx)	Rear Squeegee Assembly	1
32	82204	(000000-xxxxxx)	Retainer, R.H.	1
33	82203	(000000-xxxxxx)	Retainer, L.H.	1
34	11957	(000000-xxxxxx)	Back Up, Squeegee, Rear	1
35	82895	(000000-xxxxxx)	Blade, Squeegee, Rear	1
36	11961	(000000-xxxxxx)	Bumper, Squeegee	2
37	02942	(000000-xxxxxx)	Pin, Hair Cotter	7
38	11950	(002497-xxxxxx)	Frame, Squeegee	1
39	82576	(000000-xxxxxx)	Strip, Weight	2
40	49263	(000000-xxxxxx)	Tie, Cable	1
41	11952	(000000-xxxxxx)	Blade, Squeegee, Front	1
42	11956	(000000-xxxxxx)	Back Up, Squeegee, Front	1
43	82933	(000000-xxxxxx)	Band, Squeegee, Front	1
44	32485	(000000-xxxxxx)	Washer	6
45	03129	(000000-002496)	Replacement Kit, Squeegee Frame	1

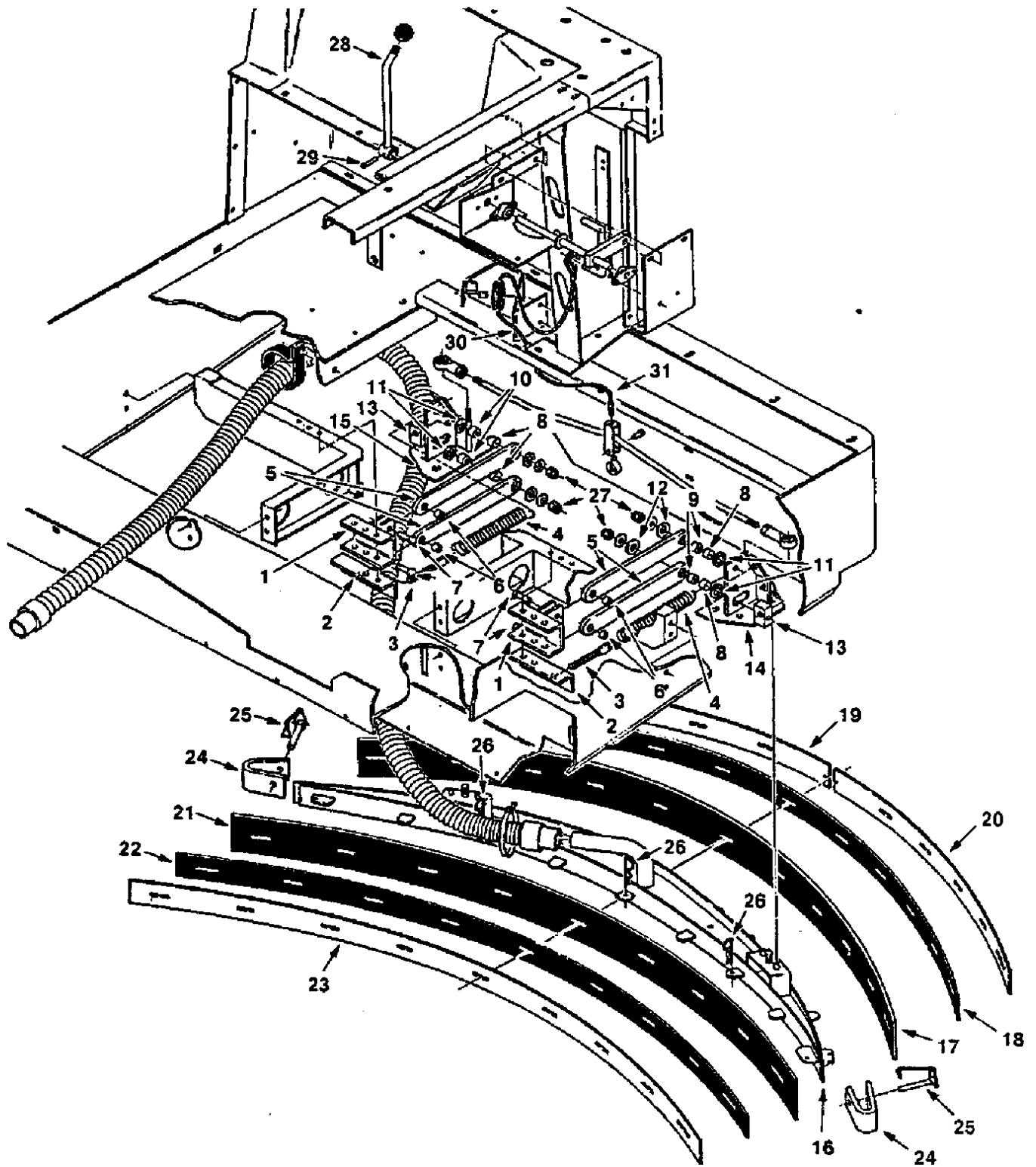

Fig. 17 - Rear Squeegee Update Group

NOTE: To identify parts shown but not listed here, see Section 5, Low Dump Model Parts.

Fig. 17 - Rear Squeegee Update Group

04504

Key	Tennant® Part No.	Machine Serial Number	Description	Qty.
1	07355	(xxxxxx-)	Bracket, Mounting, Squeegee, Frame	2
2	07352	(xxxxxx-)	Bracket, Mounting, Spring	2
3	11843	(xxxxxx-)	Bolt, Eye	2
4	33523	(xxxxxx-)	Spring, Tension	2
5	07351	(xxxxxx-)	Link	4
6	07447	(xxxxxx-)	Bearing, Bronze	4
7	86240	(xxxxxx-)	Pin, Clevis	4
8	07449	(xxxxxx-)	Bearing, Fiberglide	4
9	07382	(xxxxxx-)	Spacer	2
10	07384	(xxxxxx-)	Spacer	2
11	07448	(xxxxxx-)	Bearing, Thrust	4
12	07450	(xxxxxx-)	Bearing, Thrust	2
13	69459	(xxxxxx-)	Block, Pivot	2
14	07345	(xxxxxx-)	Bracket, Squeegee Link, L.H.	1
15	07346	(xxxxxx-)	Bracket, Squeegee Link, R.H.	1
16	11950	(xxxxxx-)	Frame, Squeegee	1
17	07051	(xxxxxx-)	Blade, Squeegee, Rear	1
18	11957	(xxxxxx-)	Back Up, Squeegee, Rear	1
19	11959	(xxxxxx-)	Retainer, R.H.	1
20	11958	(xxxxxx-)	Retainer, L.H.	1
21	11952	(xxxxxx-)	Blade, Squeegee, Front	1
22	11956	(xxxxxx-)	Back Up, Squeegee, Front	1
23	11951	(xxxxxx-)	Band, Squeegee, Front	1
24	11961	(xxxxxx-)	Bumper, Squeegee	2
25	02662	(xxxxxx-)	Pin, Keeper	2
26	02942	(xxxxxx-)	Pin, Hair Cotter	3
27	59156	(xxxxxx-)	Nut, Hex, Nylon, Lock	4
28	07360	(xxxxxx-)	Handle, Lift	1
29	23999-9	(xxxxxx-)	Pin, Roll	1
30	07063	(xxxxxx-)	Bracket, Pulley Lift	1
31	07509	(xxxxxx-)	Cable, Lift	1

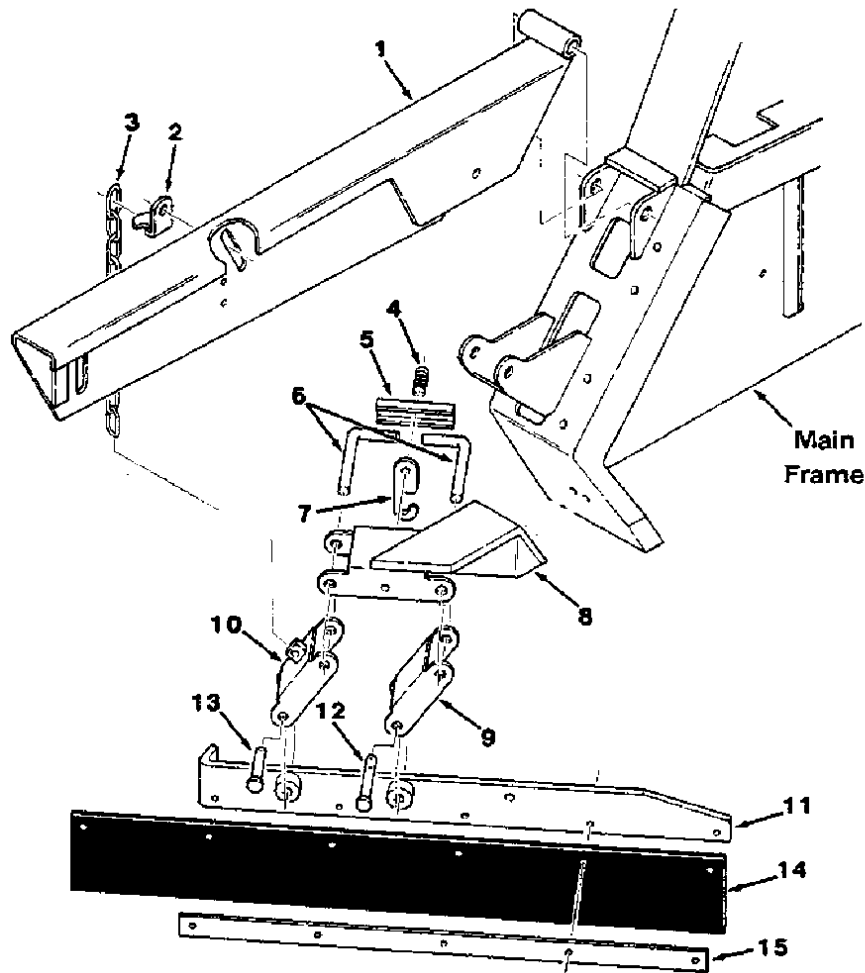

Fig. 18 - Side Squeegee Group

NOTE: Squeegees and Control Kit, Tennant Part Number 02948, includes Fig. 16, 18, 19, 24, and 28. 02729
 Squeegees and Control Kit, SE, Tennant Part Number 82091, includes Fig. 16, 18, 20, 24, and 28.

Key	Tennant® Part No.	Machine Serial Number	Description	Qty.
1	48062-1	(000000-)	Arm, Side, R.H.	1
2	43499	(000000-)	Bracket, Clip	1
3	43500	(000000-)	Chain	1
4	04428A	(000000-)	Spring, Compression	1
5	43204	(000000-)	Channel	1
6	43299	(000000-)	Pin	2
7	43549	(000000-)	Catch	1
8	43497	(000000-)	Support, Squeegee	1
9	43295	(000000-)	Link	1
10	43317	(000000-)	Link Assembly	1
11	43291	(000000-)	Support, Squeegee, Back	1
12	43553	(000000-)	Pin, Clevis	1
13	43290	(000000-)	Pin, Clevis	1
14	60013	(000000-)	Squeegee, Side	1
15	43294	(000000-)	Retainer	1

NOTE: To identify parts shown but not listed here, see Section 5, Low Dump Model Parts.

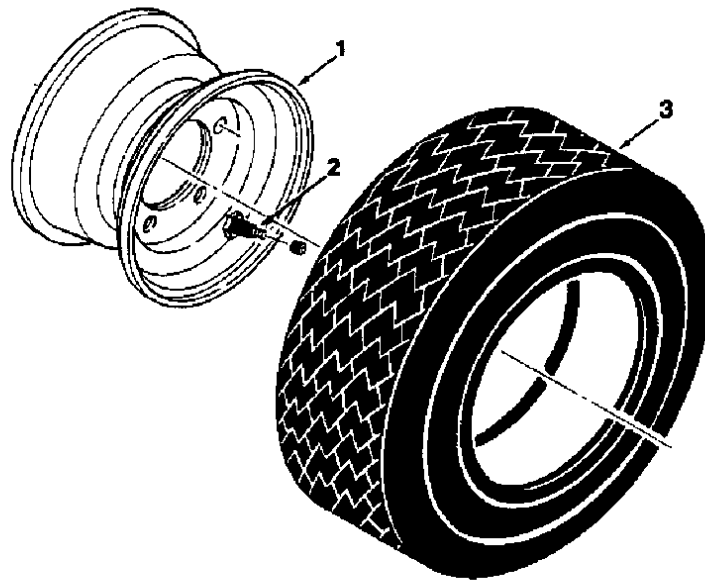

Fig. 19 - Tire and Wheel Assembly

NOTE: Squeegees and Control Kit, Tennant Part Number 02948, includes Fig. 16, 18, 19, 24, and 28. 02727

Key	Tennant® Part No.	Machine Serial Number	Description	Qty.
	82245	(000000-)	Tire and Wheel Assembly	1
1	82225	(000000-)	Wheel	1
2	75365	(000000-)	Stem, Valve	1
3	47525	(000000-)	Tire	1

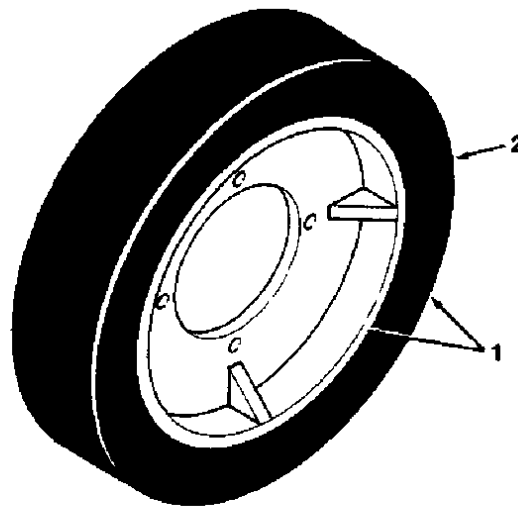

Fig. 20 - Front Wheel Assembly

NOTE: Squeegees and Control Kit, SE, Tennant Part Number 82091, includes Fig. 16, 18, 20, 24, and 28. 02616

Key	Tennant® Part No.	Machine Serial Number	Description	Qty.
1	24120	(000000-)	Tire and Wheel Assembly, Front, Solid	2
2	25197A	(000000-)	Tire, Solid	1

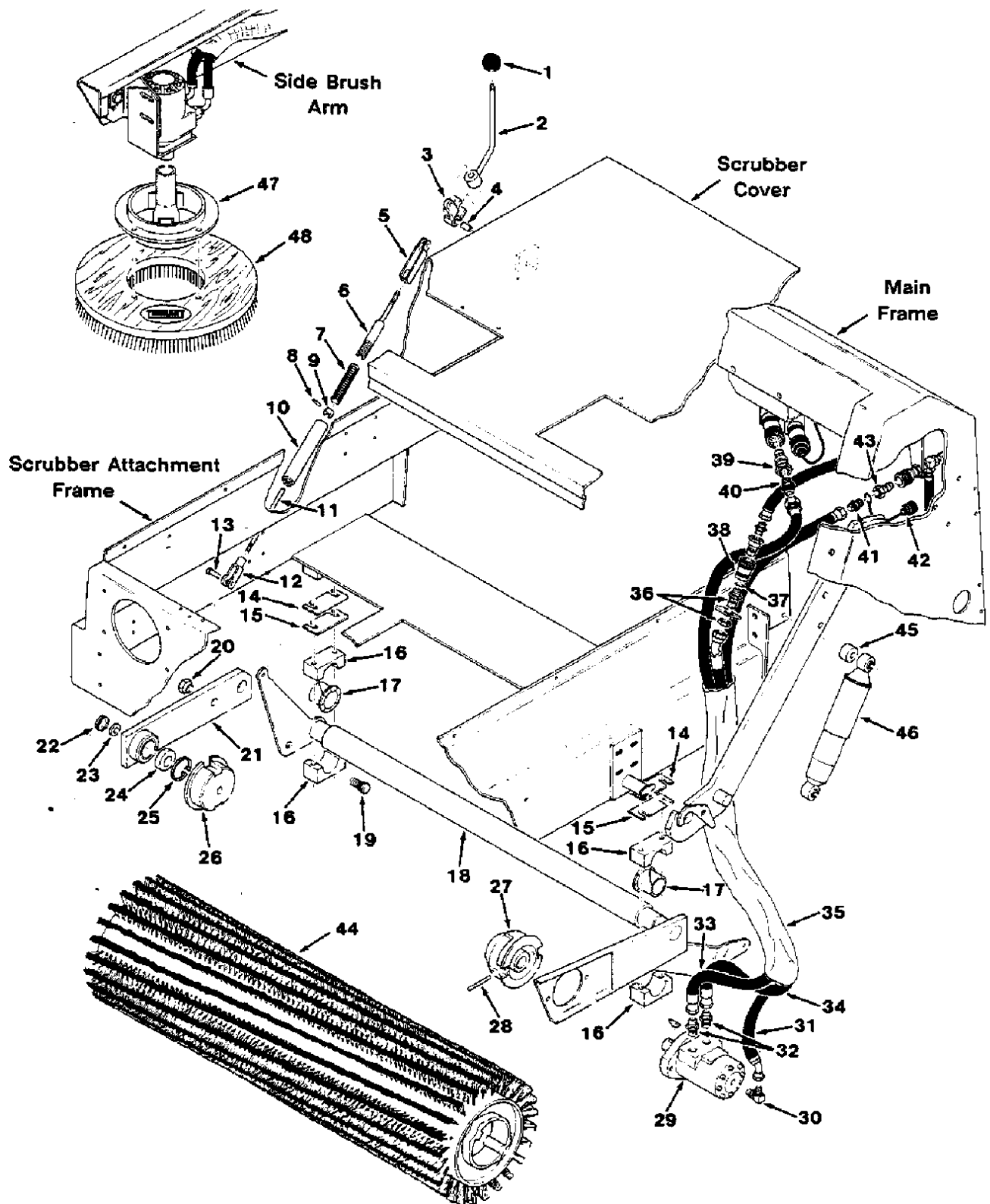

Fig. 21 - Scrubber Brush Drive Group

NOTE: To identify parts shown but not listed here, see Section 5, Low Dump Model Parts.

Fig. 21 - Scrubber Brush Drive Group

02732

NOTE: Scrubber Attachment Kit, Tennant Part Number 82088, includes Fig. 21, 22, 23, 25, 26, and 27.

Key	Tennant® Part No.	Scrub Attachment Serial Number	Description	Qty.
1	26156	(000000-)	Knob	1
2	03024	(000000-)	Handle	1
3	43086	(000000-)	Crank	1
4	26065	(000000-)	Bushing, Sleeve	1
5	43502	(000000-)	Clevis	1
6	43505	(000000-)	End, Cylinder	1
7	43164	(000000-)	Spring, Compression	1
8	20160	(000000-)	Pin, Roll	1
9	43116	(000000-)	Collar	1
10	43096	(000000-)	Spring, Cylinder	1
11	82893	(000000-)	Rod, Brush Lift	1
12	14330	(000000-)	End, Yoke	1
13	14331	(000000-)	Pin, Clevis	1
14	46642-1	(000000-)	Shim	4
15	46642-2	(000000-)	Shim	1
16	46605	(000000-)	Block, Bearing	2
17	46443	(000000-)	Bushing, Flange	2
18	43491	(000000-)	Arm and Shaft, Lift	1
19	32126	(000000-)	Stud, Wheel	1
20	24339	(000000-)	Nut, Wheel	1
21	46442	(000000-)	Arm, Brush	1
22	47178-13	(000000-)	Plugbutton	1
23	07026	(000000-)	Sleeve	1
24	46390	(000000-)	Bearing, Ball	1
25	10464	(000000-)	Ring, Retaining	1
26	07037	(000000-)	Plug, Brush	1
27	24743	(000000-)	Plug, Brush Drive	1
28	11398	(000000-)	Pin, Roll	1
29	33795	(000000-)	Motor, Hydraulic	1
30	77097	(000000-)	Fitting, Elbow	1
31	82648	(000000-)	Hose, Hydraulic	1
32	56692	(000000-)	Fitting, Straight	2
33	34356	(000000-)	Hose, Hydraulic	1
34	82506	(000000-)	Hose, Hydraulic	1
35	31646	(000000-)	Sleeve, Hose	1
36	82918	(000000-)	Fitting, Straight	1
37	77006	(000000-)	O-Ring	1
38	65084-2	(000000-)	Fitting, Coupling, Female	1
39	65084-1	(000000-)	Fitting, Coupling, Male	1
40	44869	(000000-)	Fitting, Straight	1
41	06678	(000000-)	Fitting, Straight	1
42	33798	(000000-)	Cap, Dust	1
43	34413	(000000-)	Fitting, Coupling, Male	1
44	43592	(000000-)	Brush, Polypropylene, 24 Row	1
45	43653	(000000-)	Sleeve	1
46	43652	(000000-)	Shock Absorber	1
	46857	(000000-)	Brush and U-Joint Assembly	1
47	43554	(000000-)	U-Joint	1
48	43148	(000000-)	Brush, Polypropylene	1

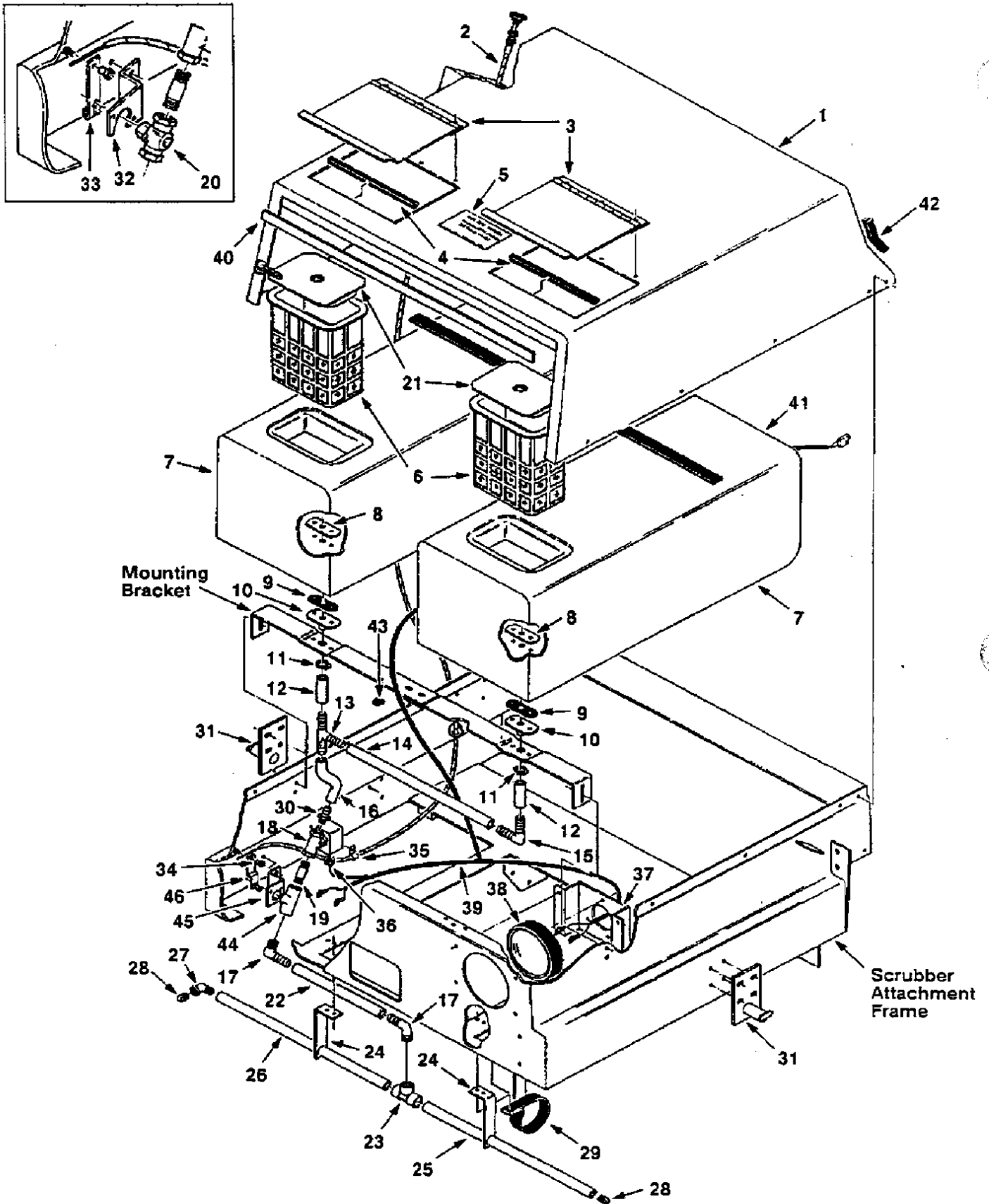

Fig. 22 - Solution Tanks Group

Fig. 22 - Solution Tanks Group

04016

NOTE: Scrubber Attachment Kit, Tennant Part Number 82088, includes Fig. 21, 22, 23, 25, 26, and 27.

Key	Tennant® Part No.	Scrub Attachment Serial Number	Description	Qty.
1	82949	(000000-)	Cover, Scrubber	1
2	03075	(000000- 020133)	Replacement Kit, Control Cable	1
2	03074	(020134-)	Cable, Control	1
3	43287	(000000-)	Lid	2
4	49282	(000000-)	Molding, Rigid	2
5	46847	(000000-)	Decal, Detergent Recommended	1
6	43516A	(000000-)	Basket, Soap	2
7	82887	(000000-)	Tank, Detergent	2
8	43056	(000000-)	Flange	2
9	43016	(000000-)	Gasket	2
10	43057	(000000-)	Connector	2
11	54333	(000000-)	Clamp	2
12	45487-1	(000000-)	Hose, Vinyl	2
13	45488	(000000-)	Fitting, Tee, Barbed	1
14	45487-3	(000000-)	Hose, Vinyl	1
15	45486	(000000-)	Fitting, Elbow, Barbed	1
16	45487-2	(000000- 020133)	Hose, Vinyl	1
16	03073	(020134-)	Hose, Vinyl	1
17	45484	(000000-)	Fitting, Elbow, Barbed	2
18	82599	(000000-)	Valve, Solenoid	1
19	11442-3	(000000-)	Fitting, Straight	1
20	12056	(000000- 030014)	Replacement Kit, Water Valve	1
21	02967	(000000-)	Plug Assembly	2
22	45487-4	(000000-)	Hose, Vinyl	1
23	56092	(000000-)	Fitting, Tee	1
24	45481	(000000-)	Hanger	2
25	56090	(000000-)	Tube, Spreader, L.H.	1
26	45528	(000000-)	Tube, Spreader, R.H.	1
27	45483-1	(000000-)	Fitting, Elbow	1
28	56119	(000000-)	Fitting, Plug	2
29	47795-1	(000000-)	Strap, Rubber	1
30	45484	(000000- 020133)	Fitting, Elbow	1
30	79273-4	(020134-)	Fitting, Straight	1
31	43039	(000000-)	Support	2
32	45490A	(000000- 020133)	Bracket, Water Valve	1
32	03033	(020134-)	Bracket, Water Valve	1
33	50573	(000000- 020133)	Lever, Water Valve	1
33	03040	(020134-)	Lever, Water Valve	1
34	43242	(000000-)	Swivel	1
35	46168	(000000-)	Clamp, Conduit	1
36	10632-4	(000000-)	Grommet	1
37	82672	(000000-)	Mount, Headlight	2
38	46108	(000000-)	Headlight	2
	10801	(000000-)	Lamp	1
39	82609	(000000-)	Wire Harness, Scrubber	1
40	02925	(000000-)	Seal, Foam	1
41	02970	(000000-)	Seal, Rubber	1
42	62170-4	(000000-)	Molding, Rigid	1
43	40678	(000000-)	Clamp, Cable	1
44	12770	(030015-)	Valve, Water	1
45	12046	(030015-)	Bracket, Water Valve	1
46	12047	(030015-)	Lever, Water Valve	1

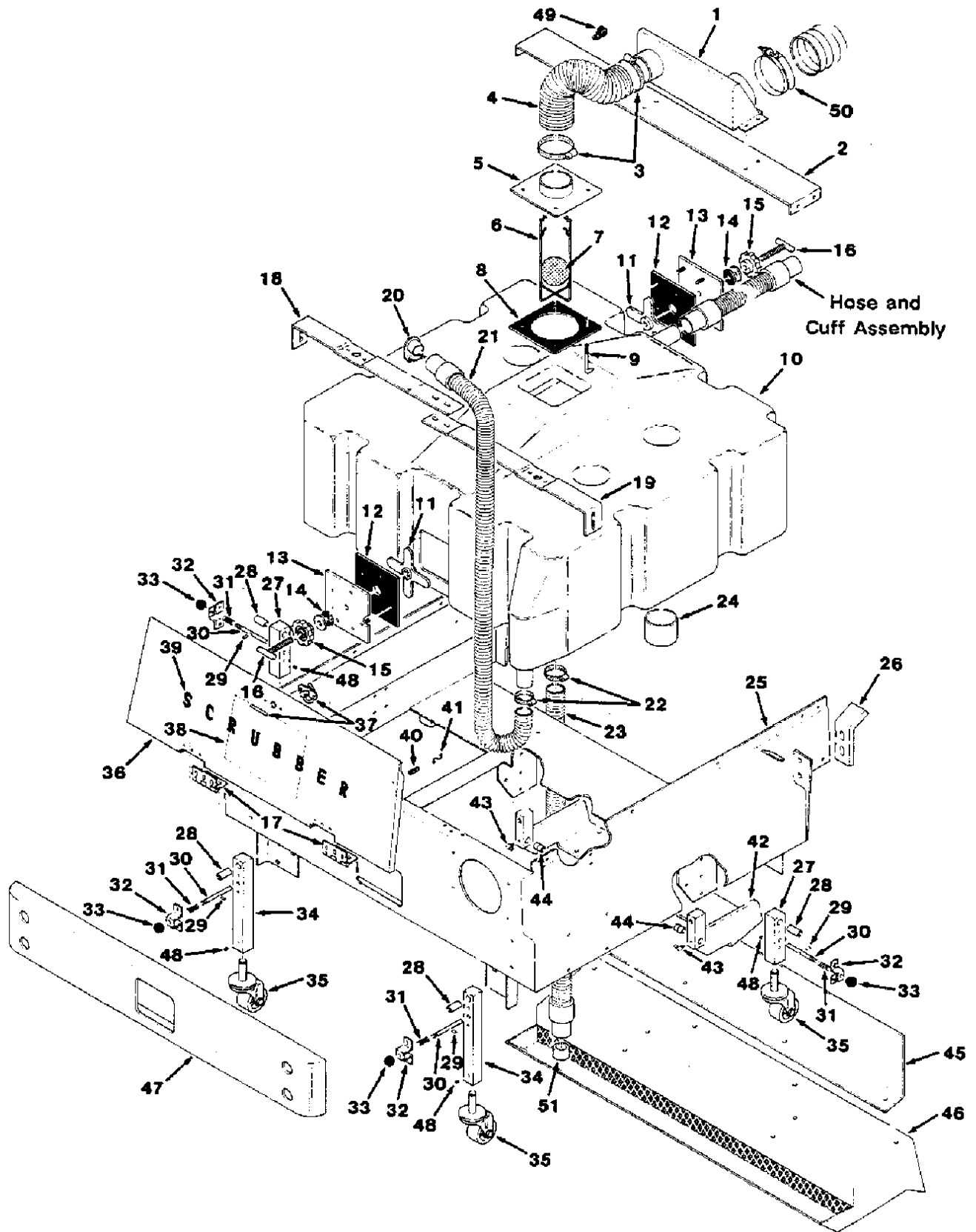

Fig. 23 - Recovery Tank Group

Fig. 23 - Recovery Tank Group

02730

NOTE: Scrubber Attachment Kit, Tennant Part Number 82088, includes Fig. 21, 22, 23, 25, 26, and 27.

Key	Tennant® Part No.	Scrub Attachment Serial Number	Description	Qty.
1	03130	(000000-	Duct, Vacuum	1
2	82959	(000000-	Brace	1
3	43555	(000000-	Clamp, Worm Drive	2
4	43490	(000000-	Hose, Flexible	1
5	47475	(000000-	Collar, Float	1
6	56489	(000000-	Guide, Float	1
7	43170	(000000-	Ball Float	1
8	43552	(000000-	Gasket	1
9	32685	(000000-	Bolt, J	4
10	82888	(000000-	Tank, Recovery	1
11	82939	(000000-	Cam, Locking	2
12	32683	(000000-	Seal, Door	2
13	82937	(000000-	Door, Cleanout	2
14	82967	(000000-	Seal, Washer	2
15	82958	(000000-	Knob	2
16	03043	(000000-	Handle, Door	2
17	47974	(000000-	Hinge	2
18	43344-1	(000000- 020133	Bracket, Mounting, R.H.	1
18	03141	(020134-	Bracket, Mounting, R.H.	1
19	43344-2	(000000- 020133	Bracket, Mounting, L.H.	1
19	03142	(020134-	Bracket, Mounting, L.H.	1
20	20215	(000000-	Plug	1
21	69207	(000000-	Hose, Drain	1
22	11531	(000000-	Clamp, Worm Drive	2
23	43207	(000000-	Hose and Cuff Assembly	1
24	32677	(000000-	Tube, Tank Locating	2
25	82864	(000000- 020133	Frame, Scrubber	1
25	03148	(020134-	Frame, Scrubber	1
26	82590	(000000-	Support, L.H.	1
27	43615	(000000-	Leg, Rear	2
28	43609	(000000-	Sieve	4
29	20160	(000000-	Pin, Roll	4
30	32449	(000000-	Pin, Threaded	4
31	04428A	(000000-	Spring, Compression	4
32	43030	(000000-	Bracket, Pin	4
33	26565	(000000-	Knob	4
34	43614	(000000-	Leg, Front	2
35	43616	(000000-	Caster, Stern	4
36	82957	(000000-	Door, Scrubber Tank	1
37	82964	(000000-	Latch, Tee	1
38	02962	(000000-	Decal, Scrubbing Instructions	1
39	46276	(000000-	Decal, Scrubber	1
40	43203	(000000-	Chain	1
41	43363	(000000-	Hook, S	1
42	43005	(000000-	Support, Trough	1
43	11048	(000000-	Fitting, Grease	2
44	26065	(000000-	Bushing, Sleeve	2
45	53368	(000000-	Shield, Spray	1
46	43004	(000000-	Trough, Pickup	1
47	82891	(000000-	Channel, Bumper	1
48	39336	(000000-	Screw, Set	4
49	26395	(000000-	Clamp	1
50	02912	(000000-	Clamp, Hose	1
51	46688	(000000-	Sleeve	1

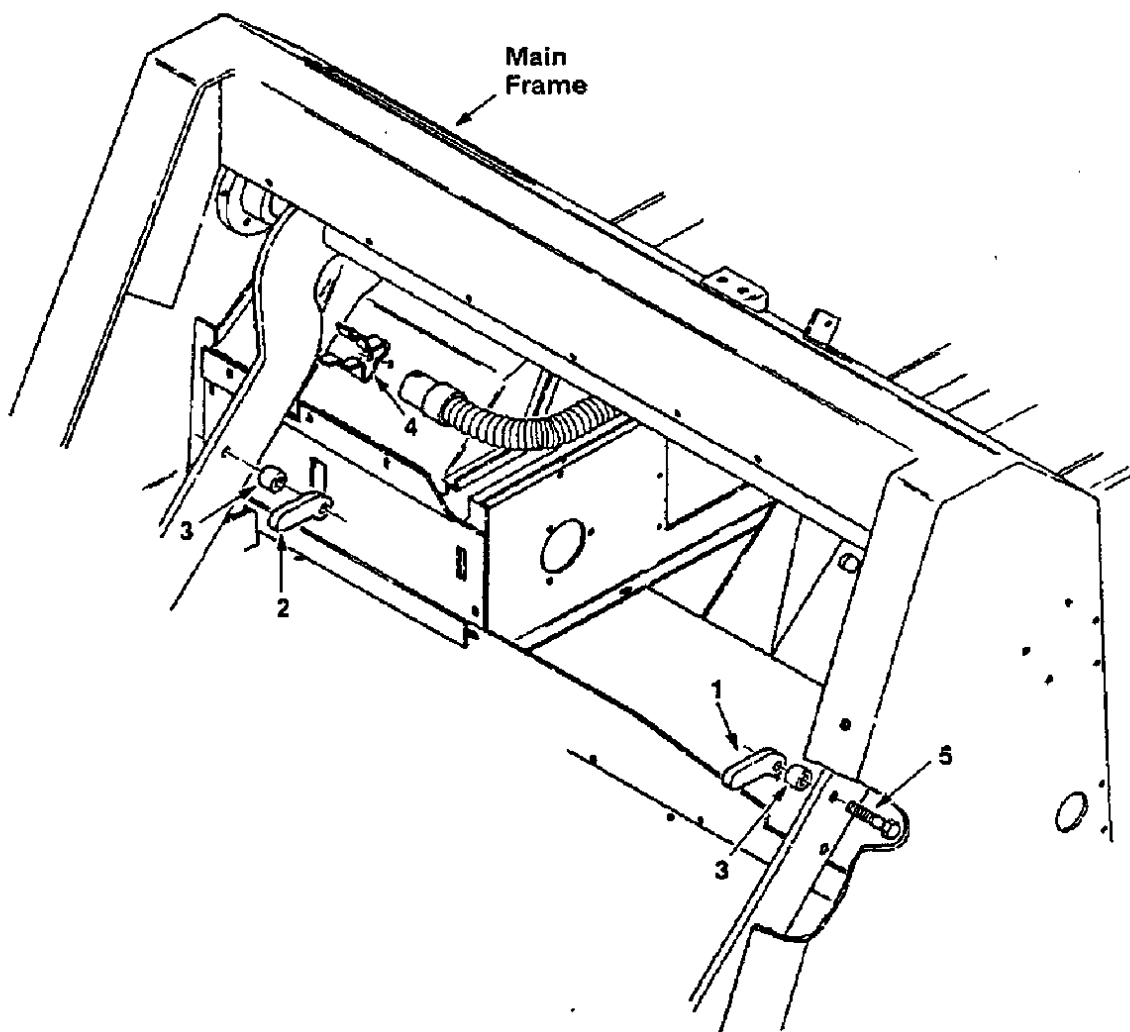

Fig. 24 - Scrub Attachment Cam Group

NOTE: Squeegees and Control Kit, Tennant Part Number 02948, includes Fig. 16, 18, 19, 24, and 28.
 Squeegees and Control Kit, SE, Tennant Part Number 82091, includes Fig. 16, 18, 20, 24, and 28.

02851

Key	Tennant® Part No.	Machine Serial Number	Description	Qty.
1	03114	(000000-)	Cam, L.H.	1
2	03139	(000000-)	Cam, R.H.	1
3	02997	(000000-)	Spacer, Cam	2
4	67004	(000000-)	Clip, Finger Grip	1
5	03112	(000000-)	Screw, Hex, L.H.	1

NOTE: To identify parts shown but not listed here, see Section 5, Low Dump Model Parts.

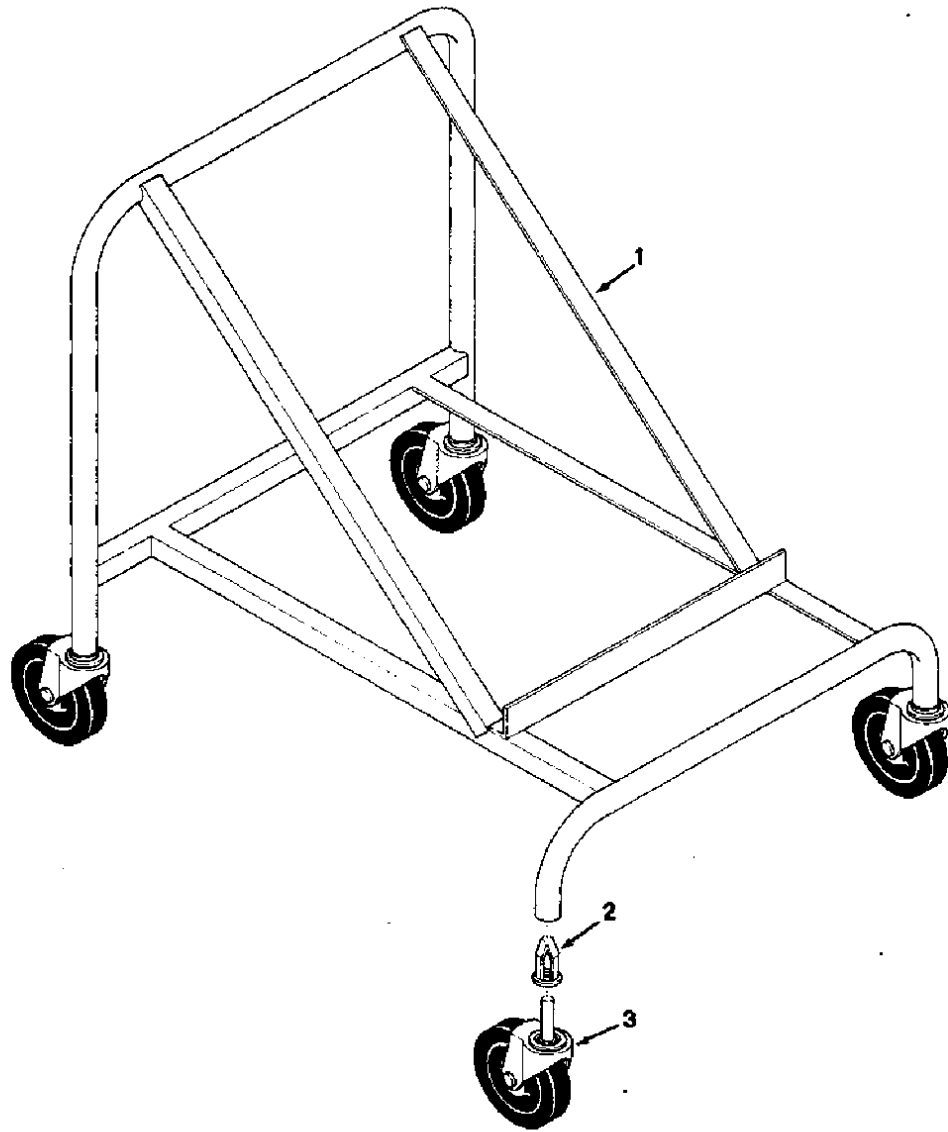

Fig. 25 - Hopper Dolly Assembly

NOTE: Scrubber Attachment Kit, Tennant Part Number 82088, includes Fig. 21, 22, 23, 25, 26, and 27. 02594
 Snow Broom Kit, Tennant Part Number 02629, includes Fig. 4, 14, 25, and 43.
 Snow Blade Kit, Tennant Part Number 37136, includes Fig. 3, 14, 25, and 43.

Key	Tennant® Part No.	Machine Serial Number	Description	Qty.
	24147	(000000-)	Dolly Assembly, Hopper	1
1	24145	(000000-)	Dolly, Hopper	1
2	24149	(000000-)	Socket, Caster	4
3	24259A	(000000-)	Caster	4

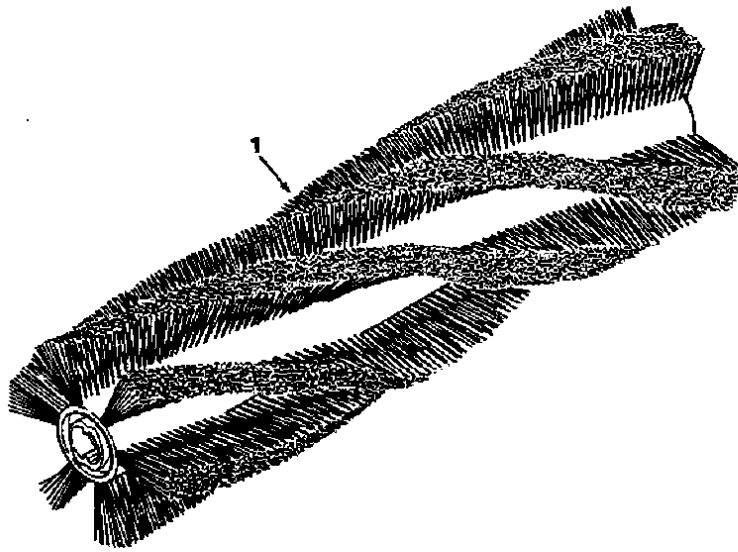

Fig. 26 - Main Scrubber Brush Group

NOTE: Scrubber Attachment Kit, Tennant Part Number 82088, includes Fig. 21, 22, 23, 25, 26, and 27. 02779

Key	Tennant® Part No.	Machine Serial Number	Description	Qty.
1	53068	(000000-)	Brush, Nylon, 8 Row	1

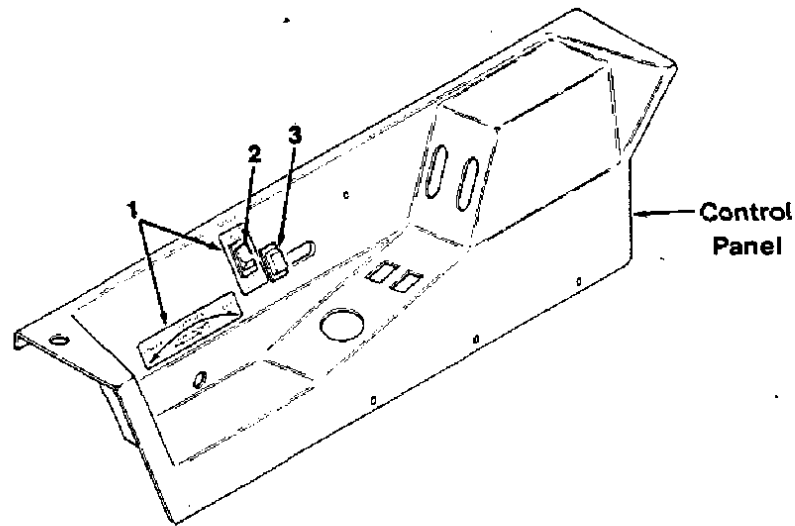

Fig. 27 - Instrument Panel Group

NOTE: Scrubber Attachment Kit, Tennant Part Number 82088, includes Fig. 21, 22, 23, 25, 26, and 27. 02726

Key	Tennant® Part No.	Machine Serial Number	Description	Qty.
1	82591	(000000-)	Label Kit	1
2	81458	(000000-)	Switch, Rocker	1
3	57807	(000000-)	Seal, Switch	1

NOTE: To identify parts shown but not listed here, see Section 5, Low Dump Model Parts.

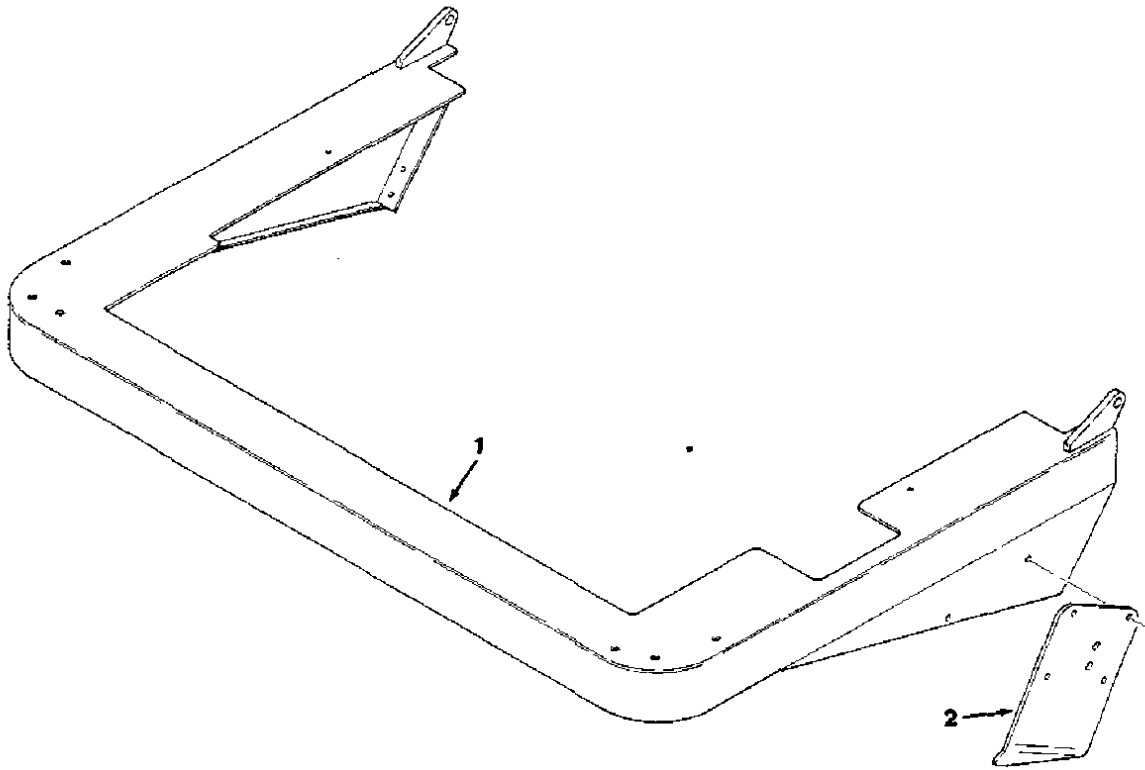

Fig. 28 - Scrubber Bumper Group

NOTE: Squeegee and Control Kit, Tennant Part Number 02948, includes Fig. 16, 18, 19, 24, and 28. Squeegee and Control Kit, SE, Tennant Part Number 82091, includes Fig. 16, 18, 20, 24, and 28.

02728

Key	Tennant® Part No.	Machine Serial Number	Description	Qty.
1	03022	(000000-)	Bumper, Scrubber	1
2	43346A	(000000-)	Guard, Motor	1

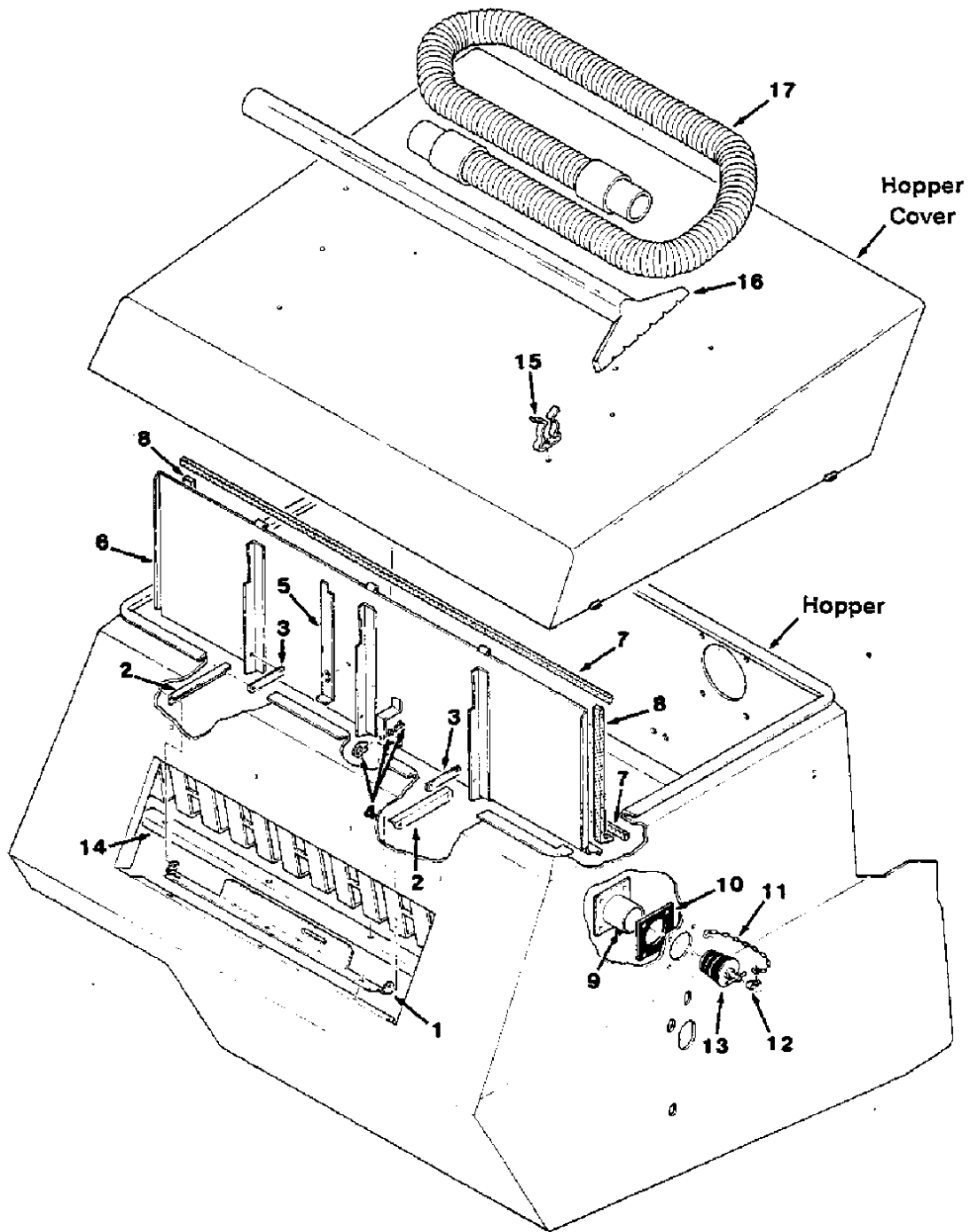

Fig. 29 - Vacuum Wand Kit, Low Dump

NOTE: To identify parts shown but not listed here, see Section 5, Low Dump Model Parts.

Fig. 29 - Vacuum Wand Kit, Low Dump

02788

Key	Tennant® Part No.	Machine Serial Number	Description	Qty.
	82978	(000000-)	Wand Kit, Vacuum	1
1	82375	(000000-)	Bracket, Stop	1
2	82376	(000000-)	Angle, Door	2
3	82439	(000000-)	Bar, Door	2
4	82315	(000000-)	Latch, Quarter Turn	1
5	82437	(000000-)	Bar, Retaining	1
6	82414	(000000-)	Door, Vacuum Wand	1
7	82297	(000000-)	Seal, Door	2
8	82296	(000000-)	Seal, Door	2
9	82458	(000000-)	Adaptor, Hose	1
10	82459	(000000-)	Seal, Adaptor	1
11	44166	(000000-)	Chain	1
12	26395-2	(000000-)	Clamp, Cable	1
13	42124	(000000-)	Plug, Drain	1
14	82419	(000000-)	Angle, Baffle	1
15	67004	(000000-)	Clip, Finger Grip	7
16	54012	(000000-)	Wand	1
17	54009	(000000-)	Hose and Cuff Assembly	1

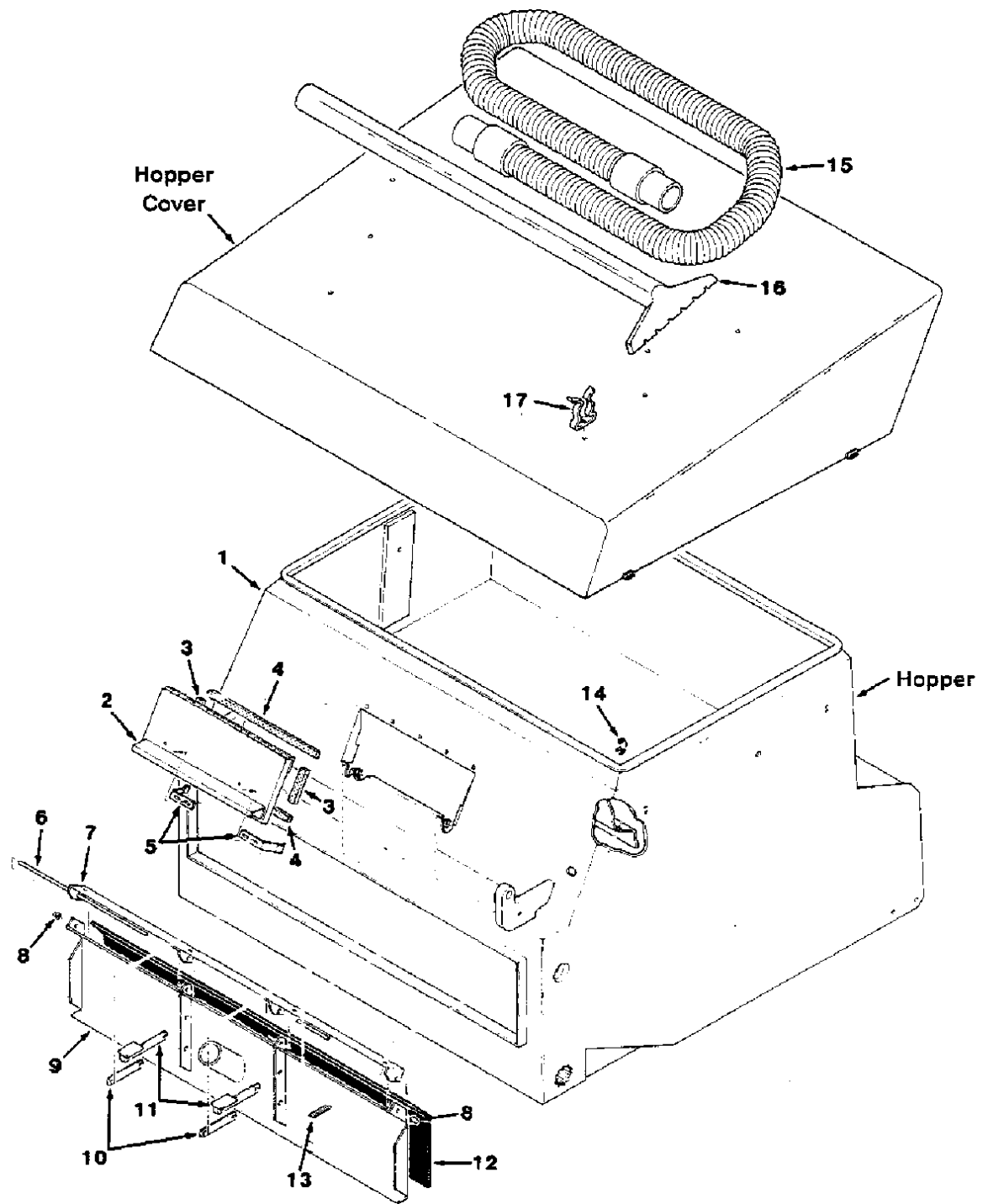

Fig. 30 - Vacuum Wand Group, Multi-Level Dump

NOTE: To identify parts shown but not listed here, see Section 5, Low Dump Model Parts.

Fig. 30 - Vacuum Wand Group, Multi-Level Dump

02802

Key	Tennant® Part No.	Machine Serial Number	Description	Qty.
1	07999	(000000-)	Hopper, Vacuum Wand	1
2	50590	(000000-)	Door, Access	1
3	75423	(000000-)	Seal, Foam Rubber	2
4	50525	(000000-)	Seal, Foam Rubber	2
5	53697	(000000-)	Catch, Spring	2
6	82283	(000000-)	Pin, Hinge	1
7	82280	(000000-)	Mount, Hinge	1
8	82284	(000000-)	Fastener, Cap	2
9	82275	(000000-)	Door, Vacuum Wand	1
10	82288	(000000-)	Link, Outer	2
11	82270	(000000-)	Link	2
12	82292	(000000-)	Seal, Door	1
13	13352	(000000-)	Spring	1
14	47591	(000000-)	Strain Relief	1
15	54009	(000000-)	Hose and Cuff Assembly	1
16	54012	(000000-)	Wand	1
17	67004	(000000-)	Clip, Finger Grip	7

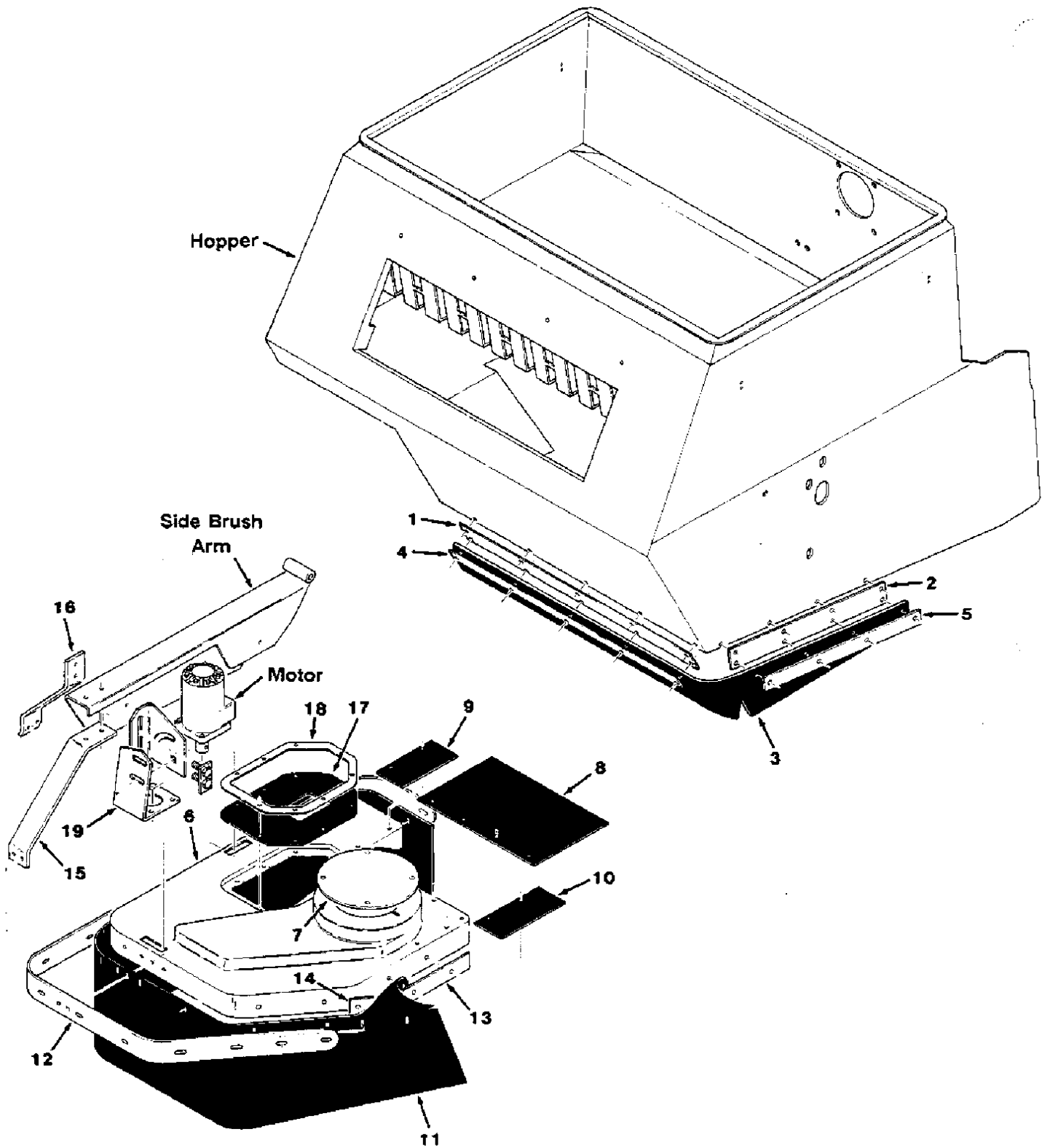

Fig. 31 - Side Brush Dust Control Kit, Low Dump

NOTE: To identify parts shown but not listed here. see Section 5, Low Dump Model Parts.

Fig. 31 - Side Brush Dust Control Kit, Low Dump

02783

NOTE: Side Brush Control Kit, SE, Tennant Part Number 03126, includes Fig. 31 and 34.

Key	Tennant® Part No.	Machine Serial Number	Description	Qty.
	03122	(000000-)	Dust Control Kit, Side Brush	1
1	03119	(000000-)	Strip, Skirt Front	1
2	03120	(000000-)	Strip, Skirt, L.H.	1
3	03101	(000000-)	Skirt, Hopper	1
4	03104	(000000-)	Retainer, Front	1
5	03102	(000000-)	Retainer, L.H.	1
6	53098	(000000-)	Shroud , Side Brush	1
7	03121	(000000-)	Plate, Shroud Cover	1
8	03111	(000000-)	Seal, Rear Shroud	1
9	53109	(000000-)	Seal, Hopper	1
10	03109	(000000-)	Seal, Left Front	1
11	03096	(000000-)	Skirt, Shroud	1
12	03095	(000000-)	Retainer, Shroud Skirt	1
13	03105	(000000-)	Retainer, Skirt	1
14	03108	(000000-)	Retainer, Skirt	1
15	53038	(000000-)	Support, Front Bumper	1
16	53039	(000000-)	Support, Side Bumper	1
17	53407	(000000-)	Seal, Shroud Shaft	1
18	53212	(000000-)	Retainer, Shroud Seal	1
19	82721	(000000-)	Bracket, Motor	1

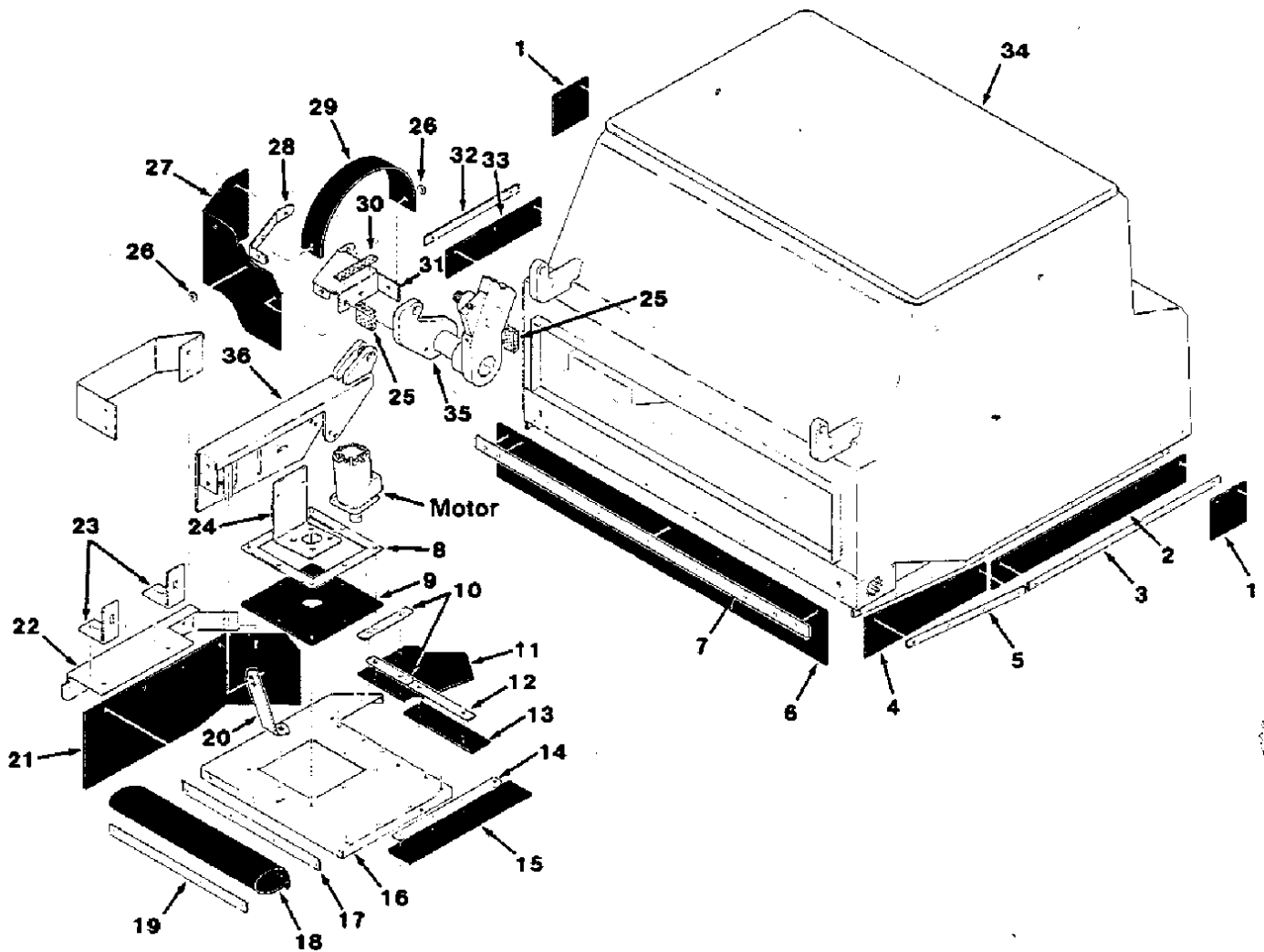



Fig. 32 - Side Brush Dust Control Kit (with Hopper), Multi-Level Dump

NOTE: To identify parts shown but not listed here, see Section 7, Multi-Level Dump Model Parts.

Fig. 32 - Side Brush Dust Control Kit (with Hopper), Multi-Level Dump

03354

Key	Tennant® Part No.	Machine Serial Number	Description	Qty.
	04579	(00000-)	Dust Control Kit, Side Brush, (with Hopper)	1
1	04546	(000000-)	Skirt, Rear Side	2
2	04544	(000000-)	Skirt, L.H.	1
3	04566	(000000-)	Retainer, L.H.	1
4	04545	(000000-)	Skirt, Front, L.H.	1
5	04568	(000000-)	Retainer, Front, L.H.	1
6	04577	(000000-)	Skirt, Front	1
7	04564	(000000-)	Retainer, Front	1
8	04569	(000000-)	Retainer, Motor Seal	1
9	04554	(000000-)	Seal, Motor	1
10	04562	(000000-)	Retainer, R.H.	2
11	04550	(000000-)	Seal, Rear Corner	1
12	04559	(000000-)	Retainer, Shroud Rear	1
13	04552	(000000-)	Seal, Shroud Rear	1
14	04561	(000000-)	Retainer, Shroud, L.H.	1
15	04551	(000000-)	Seal, Shroud, L.H.	1
16	04542	(000000-)	Shroud, Side Brush	1
17	04563	(000000-)	Deflector, Shroud Front	1
18	04549	(000000-)	Seal, Shroud Front	1
19	04560	(000000-)	Retainer, Shroud Front	1
20	04575	(000000-)	Strap, Shroud Front	1
21	04547	(000000-)	Skirt, Shroud, R.H.	1
22	04558	(000000-)	Bumper, Shroud	1
23	04574	(000000-)	Angle, Shroud Support	2
24	04576	(000000-)	Bracket, Side Brush Motor	1
25	82125	(000000-)	Seal, Foam Rubber	2
26	41186	(000000-)	Washer, Belleville	2
27	04548	(000000-)	Skirt, Front Corner	1
28	04570	(000000-)	Retainer, Corner Bumper	1
29	04553	(000000-)	Seal, Rollout Shaft	1
30	78218-2	(000000-)	Seal, Foam Rubber	1
31	04555	(000000-)	Bumper, Corner	1
32	04565	(000000-)	Retainer, R.H.	1
33	04543	(000000-)	Skirt, R.H.	1
34	04529	(000000-)	Hopper	1
35	04541	(000000-)	Shaft, Torque, R.H.	1
36	04539	(000000-)	Arm, Side Brush	1

Home	Find...	Go To..		
------	---------	---------	---	---

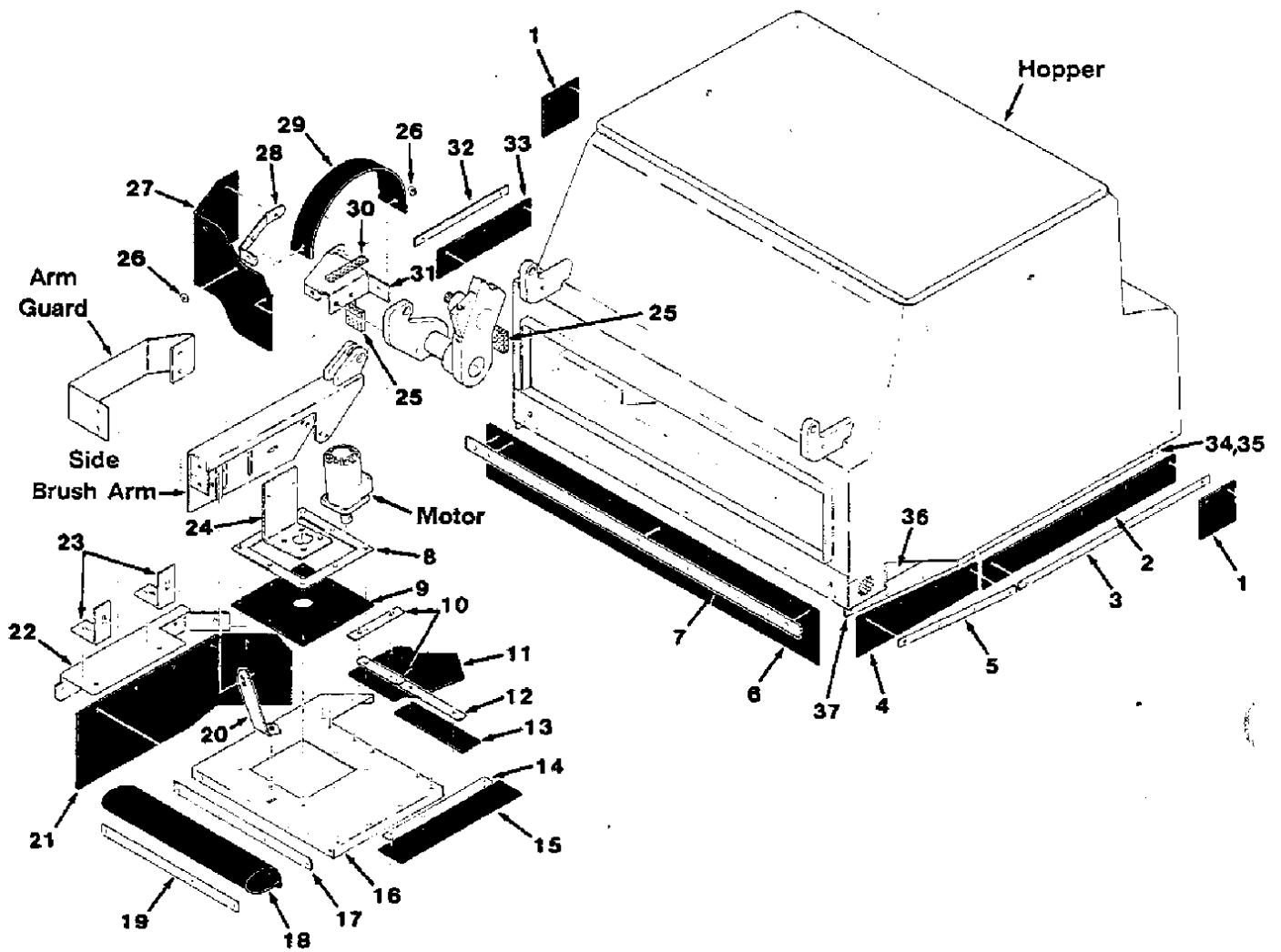

Fig. 33 - Side Brush Dust Control Kit, Multi-Level Dump

NOTE: To identify parts shown but not listed here, see Section 7, Multi-Level Dump Model Parts.

Fig. 33 - Side Brush Dust Control Kit, Multi-Level Dump

03443

Key	Tennant® Part No.	Machine Serial Number	Description	Qty.
	04527	(00000-)	Dust Control Kit, Side Brush	1
1	04546	(000000-)	Skirt, Rear Side	2
2	04544	(000000-)	Skirt, L.H.	1
3	04566	(000000-)	Retainer, L.H.	1
4	04545	(000000-)	Skirt, Front, L.H.	1
5	04568	(000000-)	Retainer, Front, L.H.	1
6	04577	(000000-)	Skirt, Front	1
7	04564	(000000-)	Retainer, Front	1
8	04569	(000000-)	Retainer, Motor Seal	1
9	04554	(000000-)	Seal, Motor	1
10	04562	(000000-)	Retainer, R.H.	2
11	04550	(000000-)	Seal, Rear Corner	1
12	04559	(000000-)	Retainer, Shroud Rear	1
13	04552	(000000-)	Seal, Shroud Rear	1
14	04561	(000000-)	Retainer, Shroud, L.H.	1
15	04551	(000000-)	Seal, Shroud, L.H.	1
16	04542	(000000-)	Shroud, Side Brush	1
17	04563	(000000-)	Deflector, Shroud Front	1
18	04549	(000000-)	Seal, Shroud Front	1
19	04560	(000000-)	Retainer, Shroud Front	1
20	04575	(000000-)	Strap, Shroud Front	1
21	04547	(000000-)	Skirt, Shroud, R.H.	1
22	04558	(000000-)	Bumper, Shroud	1
23	04574	(000000-)	Angle, Shroud Support	2
24	04576	(000000-)	Bracket, Side Brush Motor	1
25	82125	(000000-)	Seal, Foam Rubber	2
26	41186	(000000-)	Washer, Belleville	2
27	04548	(000000-)	Skirt, Front Corner	1
28	04570	(000000-)	Retainer, Corner Bumper	1
29	04553	(000000-)	Seal, Rollout Shaft	1
30	78218-2	(000000-)	Seal, Foam Rubber	1
31	04555	(000000-)	Bumper, Corner	1
32	04565	(000000-)	Retainer, R.H.	1
33	04543	(000000-)	Skirt, R.H.	1
34	04534	(000000-)	Strip, Skirt Support	1
35	04535	(000000-)	Strip, Skirt Support	1
36	04537	(000000-)	Plate, Front Filler	2
37	04538	(000000-)	Plate, Front Skirt	1

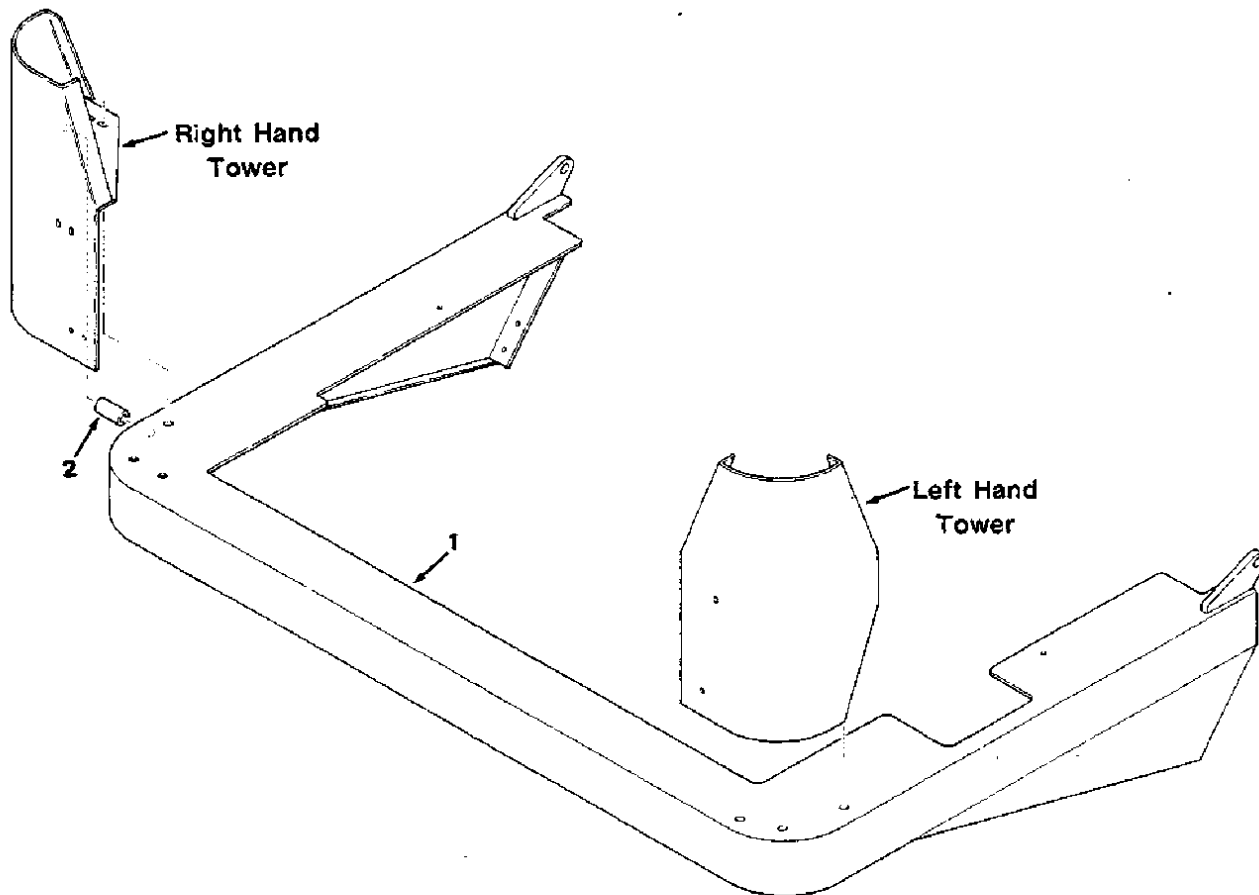

Fig. 34 - Bumper Group, SE Side Brush Dust Control

02782

NOTE: Side Brush Control Kit, SE, Tennant Part Number 03126, includes Fig. 31 and 34.

Key	Tennant® Part No.	Machine Serial Number	Description	Qty.
1	03022	(000000-)	Bumper	1
2	82179	(000000-)	Sleeve	1

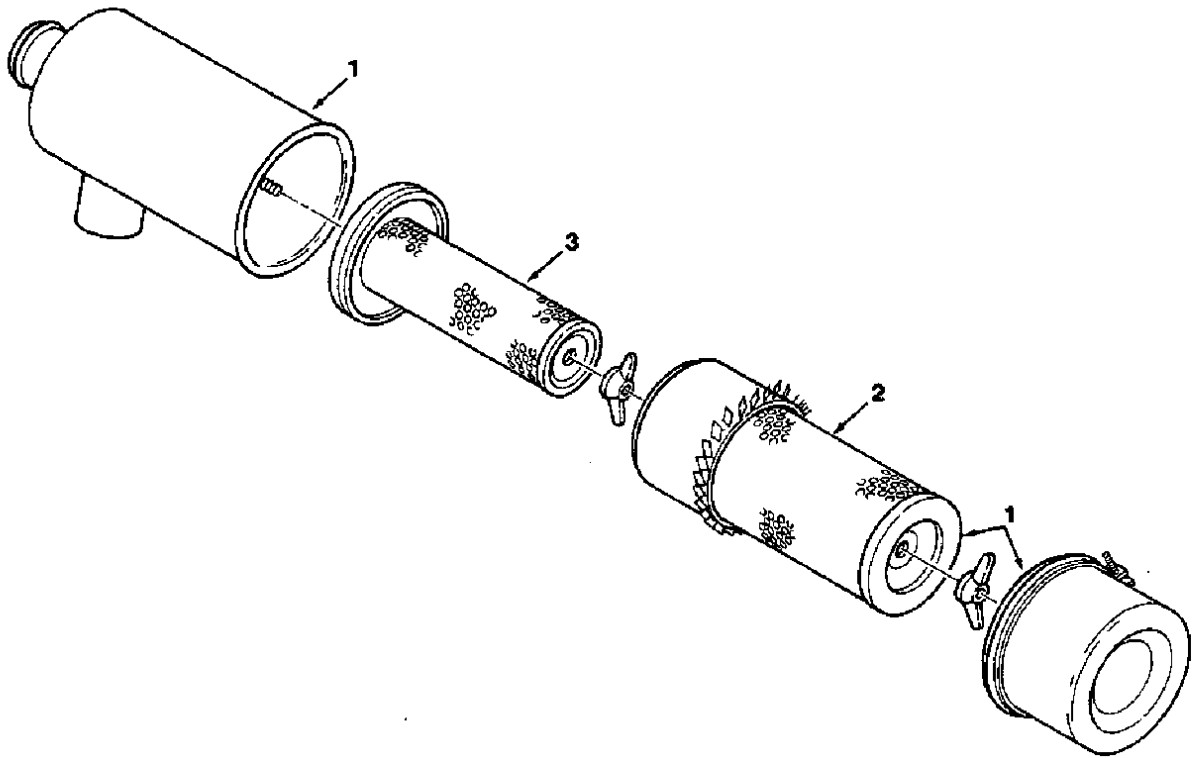

Fig. 35 - Air Cleaner Kit, Heavy Duty

02274

Key	Tennant® Part No.	Machine Serial Number	Description	Qty.
	58539	(000000-)	Air Cleaner Kit, Heavy Duty	1
1	58538	(000000-)	Body, Air Cleaner	1
2	58120	(000000-)	Element, Air Cleaner	1
3	58121	(000000-)	Element, Safety	1

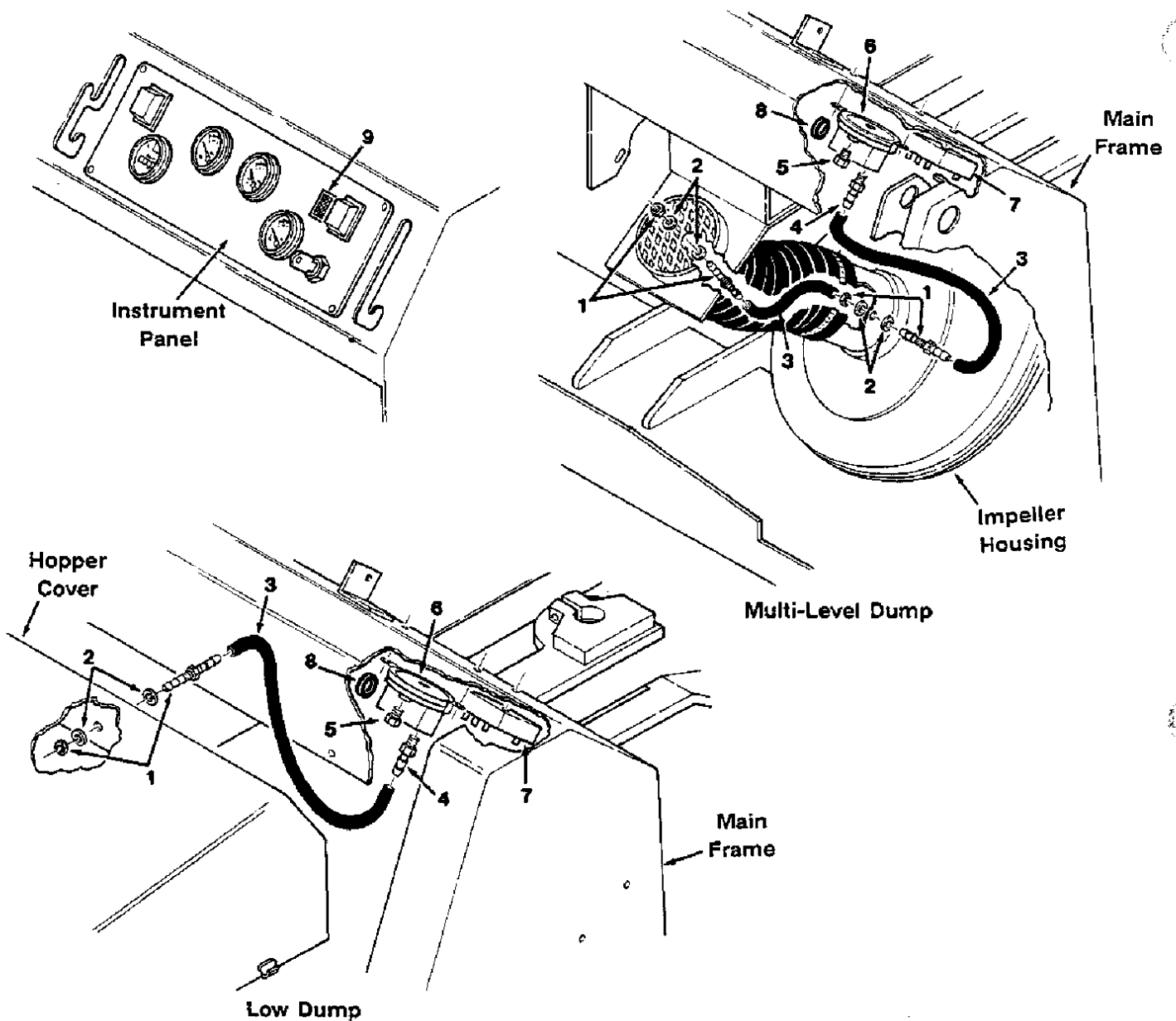

Fig. 36 - Clogged Filter Indicator Kit

Key	Tennant® Part No.	Machine Serial Number	Description	Qty.
	02632	(000000-)	Indicator Kit, Clogged Filter	1
1	39923	(000000-)	Fitting, Bulkhead, Barbed	2
2	43454	(000000-)	Washer, Nylon	4
3	39780-1	(000000-)	Hose, Rubber	1
4	40607	(000000-)	Fitting, Straight, Barbed	1
5	82739	(000000-)	Fitting, Breather	1
6	34868	(000000-)	Switch, Pressure	1
7	34816	(000000-)	Timer, Shaker	1
8	10632-4	(000000-)	Grommet	1
9	64141-1	(000000-)	Light Assembly	1

NOTE: To identify parts shown but not listed here, see Section 5, Low Dump Model Parts.

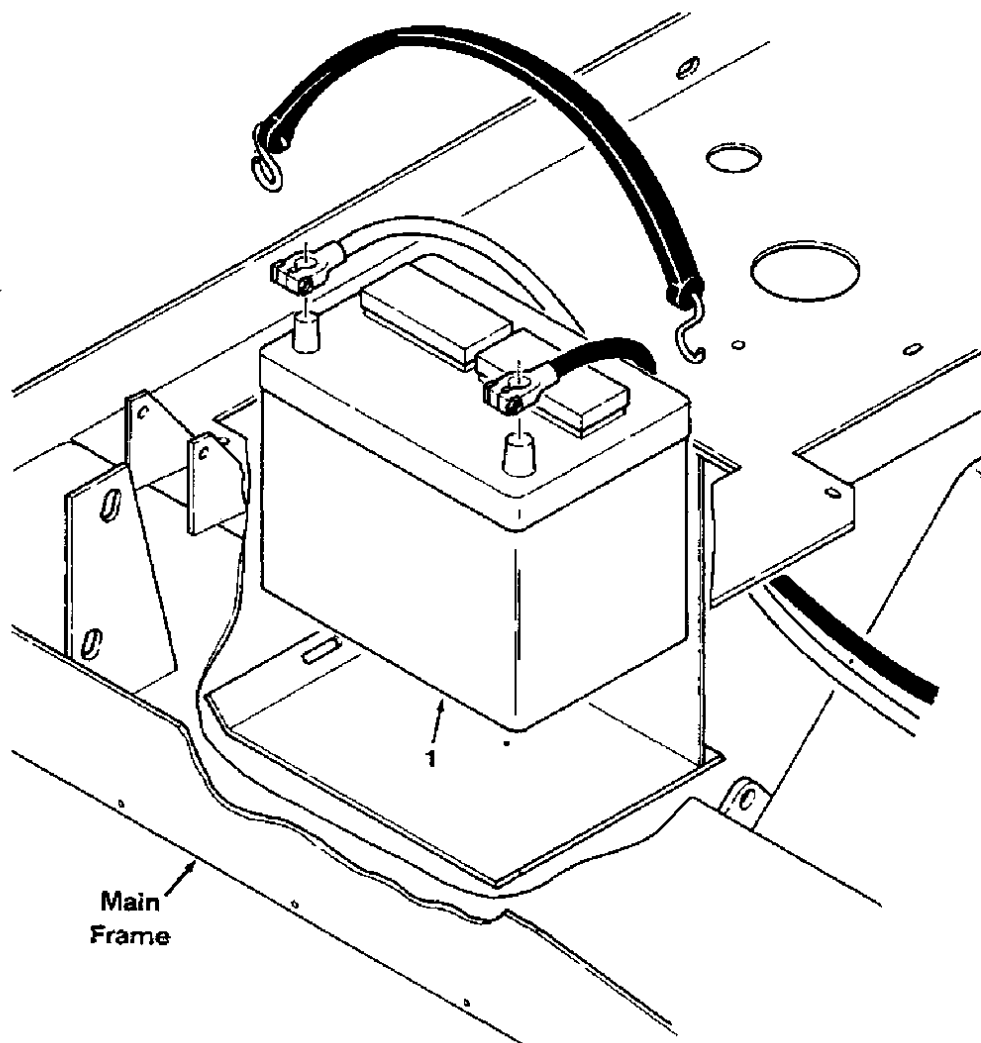

Fig. 37 - Dry Battery Kit

02797

Key	Tennant® Part No.	Machine Serial Number	Description	Qty.
1	10144	(000000-)	Battery, Dry, 540 CCA	1

NOTE: To identify parts shown but not listed here, see Section 5, Low Dump Model Parts.

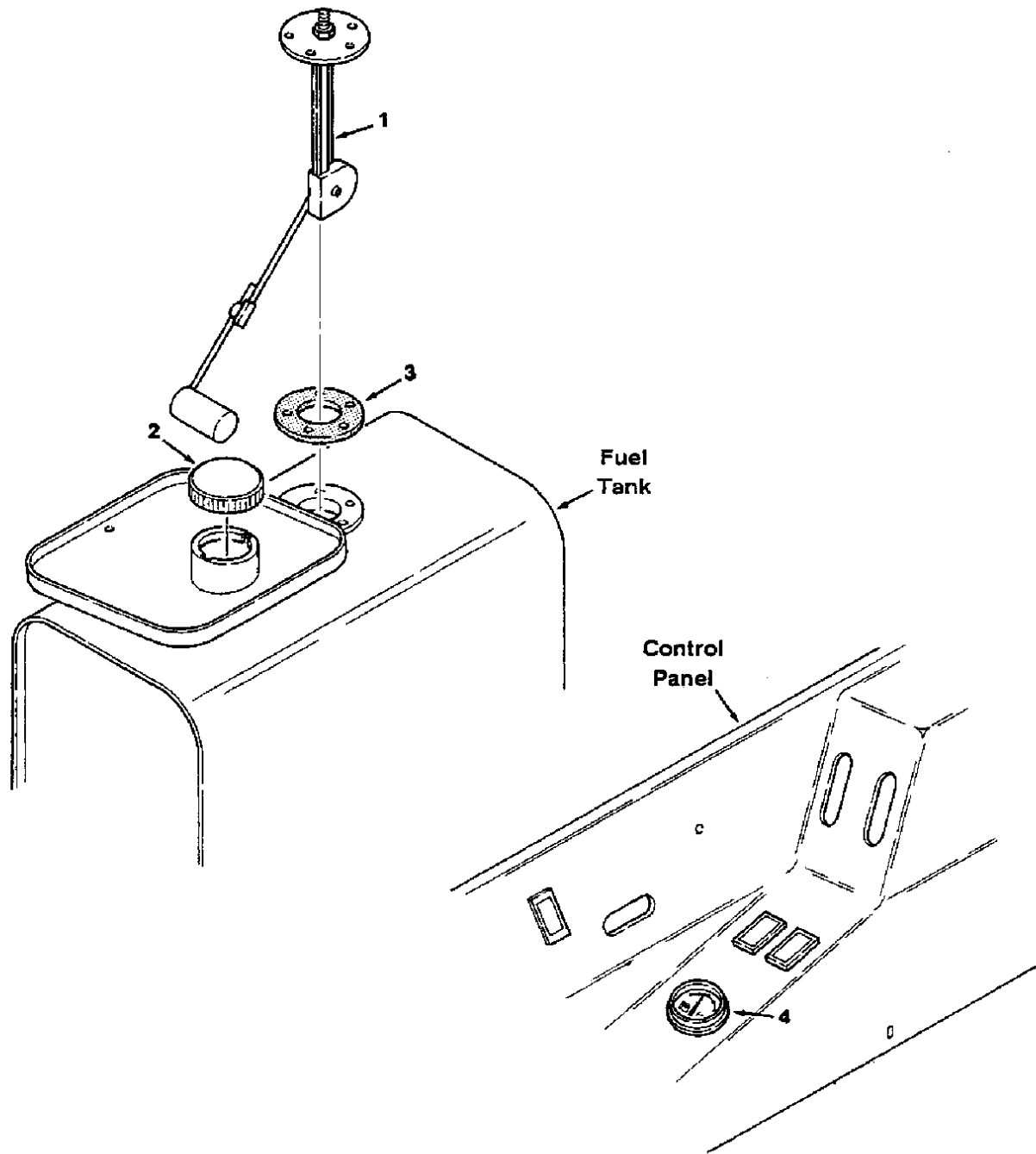

Fig. 38 - Fuel Gauge Kit

02592

Key	Tennant® Part No.	Machine Serial Number	Description	Qty.
	82994	(000000-)	Gauge Kit, Fuel	1
1	47473	(000000-)	Sending Unit, Tank	1
2	48267	(000000-)	Cap, Tank	1
3	14131	(000000-)	Gasket	1
4	34813	(000000-)	Gauge, Fuel	1

NOTE: To identify parts shown but not listed here, see Section 5, Low Dump Model Parts.

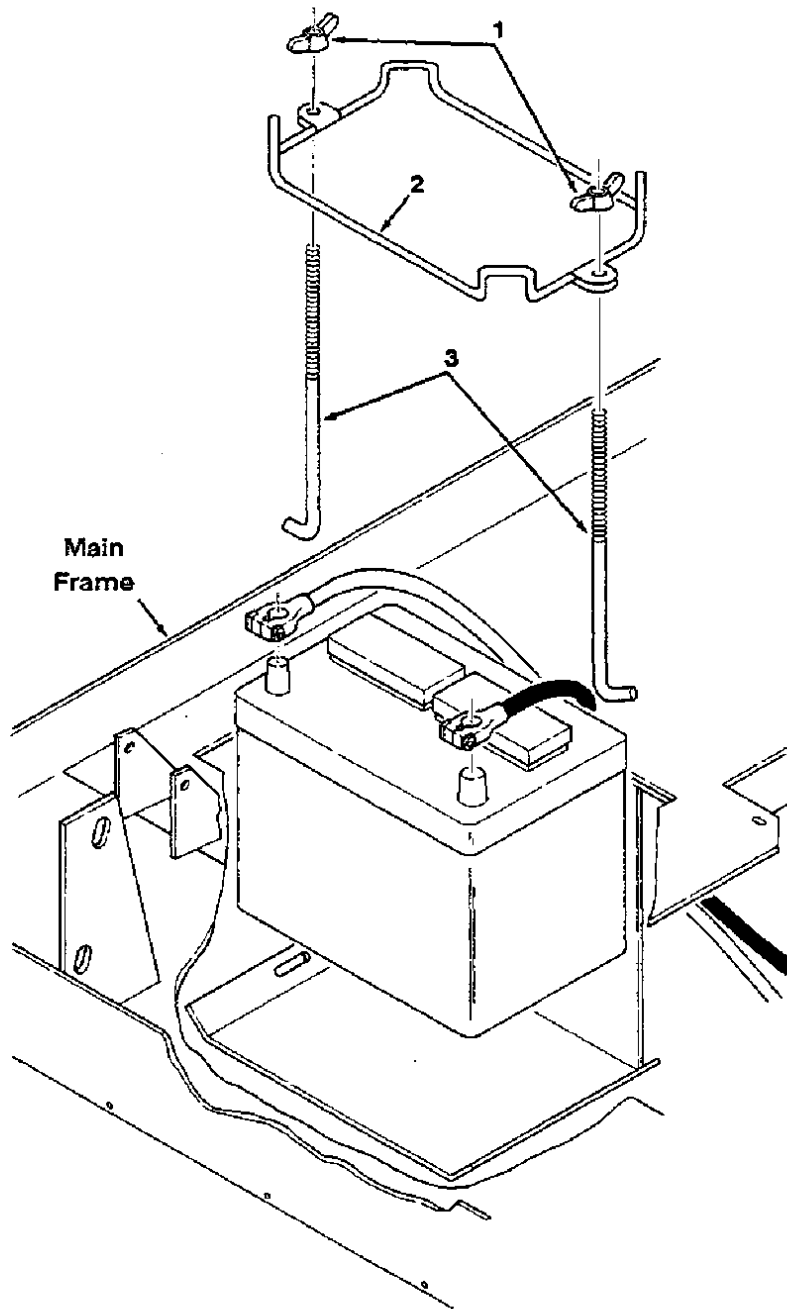

Fig. 39 – Battery Hold Down Kit

Key	Tennant® Part No.	Machine Serial Number	Description	Qty.
	82922	(000000-)	Hold Down Kit, Battery	1
1	39272	(000000-)	Nut, Wing	2
2	13016	(000000-)	Bracket, Hold Down	1
3	13015-2	(000000-)	Bolt, Hold Down	2

NOTE: To identify parts shown but not listed here, see Section 5, Low Dump Model Parts.

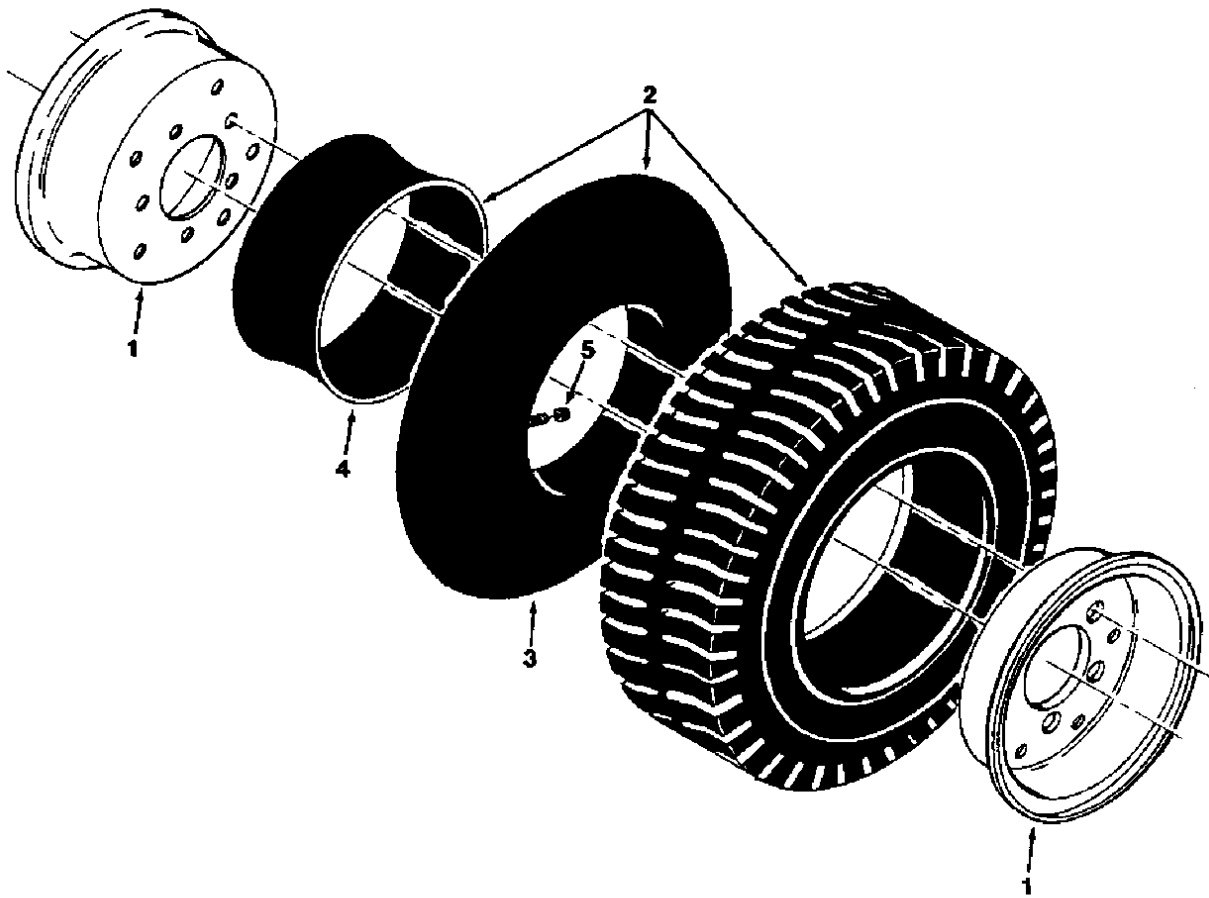

Fig. 40 - Rear Wheel Assembly, Steelguard

02588

Key	Tennant® Part No.	Machine Serial Number	Description	Qty.
1	53640	(000000-)	Tire and Wheel Assembly, Steelguard	1
	53818	(000000-)	Rim Assembly	1
2	53819	(000000-)	Tire, Tube and Flap Assembly	1
3	53819-1	(000000-)	Tube, Inner	1
4	53819-2	(000000-)	Flap, Tube	1
5	45786	(000000-)	Cap. Valve Stem	1

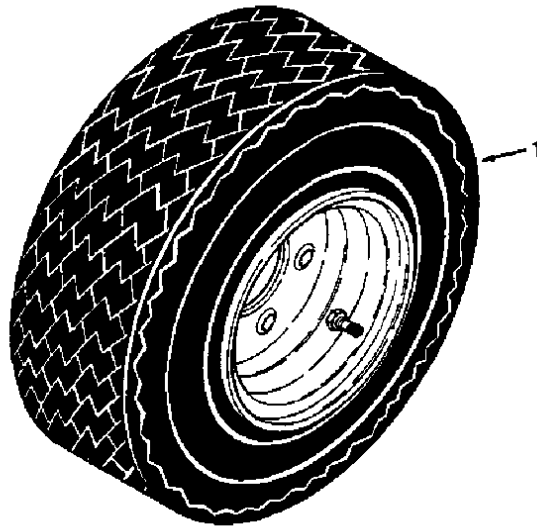

Fig. 41 - Rear Wheel Assembly, Foam Filled

Key	Tennant® Part No.	Machine Serial Number	Description	Qty.
1	82924	(000000-)	Tire and Wheel Assembly, Foam Filled	1

02586

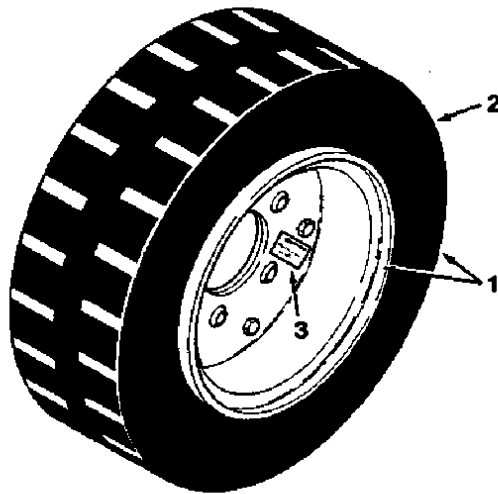

Fig. 42 - Rear Wheel Assembly, Solid

Key	Tennant® Part No.	Machine Serial Number	Description	Qty.
1	53817	(000000-)	Tire and Wheel Assembly, Solid	1
2	53816	(000000-)	Tire, Solid	1
3	24507	(000000-)	Decal, Caution, This Side Out	1

02587

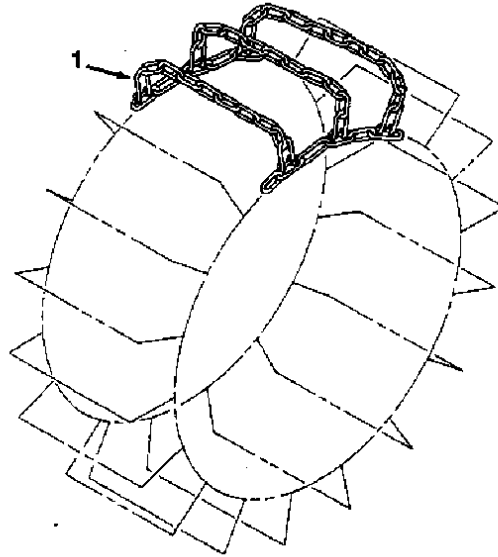

Fig. 43 - Tire Chain Kit

*NOTE: Snow Broom Kit, Tennant Part Number 02629, includes Fig. 4, 14, 25, and 43.
 Snow Blade Kit, Tennant Part Number 37136, includes Fig. 3, 14, 25, and 43.*

02591

Key	Tennant® Part No.	Machine Serial Number	Description	Qty.
1	53848	(000000-)	Chain, Tire	1

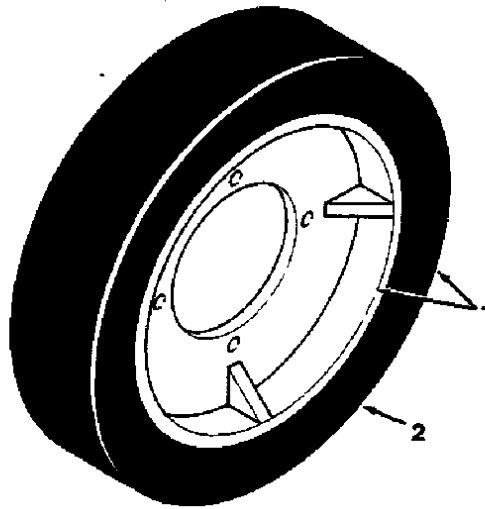

Fig. 44 - Front Wheel Assembly, Low Dump

Key	Tennant® Part No.	Machine Serial Number	Description	Qty.
1	24120	(000000-)	Tire and Wheel Assembly, Front, Solid	2
2	25197A	(000000-)	Tire, Solid	1

02616

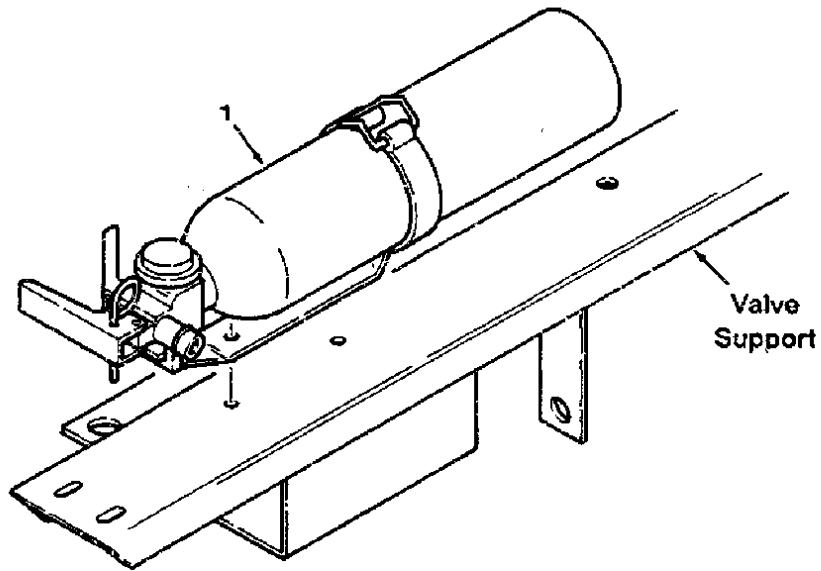

Fig. 45 - Fire Extinguisher Kit

02597

Key	Tennant® Part No.	Machine Serial Number	Description	Qty.
1	46938 25312	(000000-) (000000-)	Extinguisher Kit, Fire Extinguisher, Fire	1 1

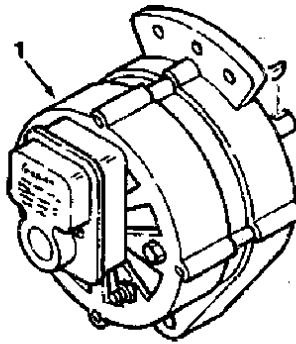

Fig. 46 - Alternator Kit

02798

Key	Tennant® Part No.	Machine Serial Number	Description	Qty.
1	82511	(000000-)	Alternator, Sealed	1

NOTE: To identify parts shown but not listed here, see Section 5, Low Dump Model Parts.

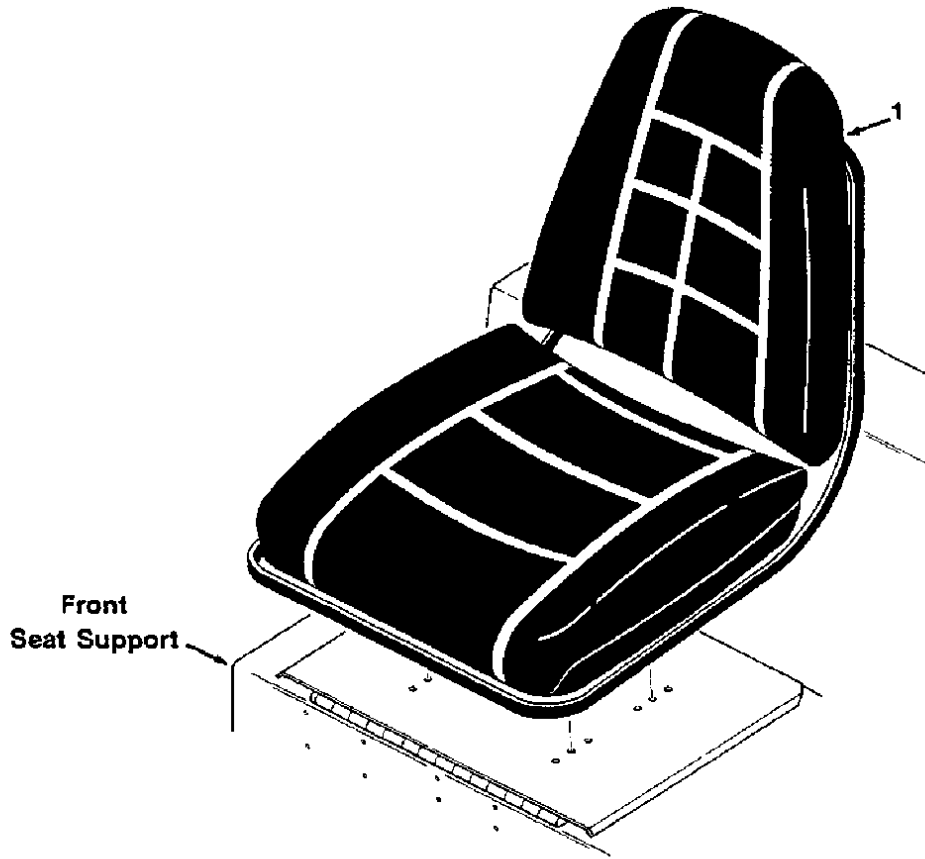

Fig. 47 - Suspension Seat Kit

02595

Key	Tennant® Part No.	Machine Serial Number	Description	Qty.
1	82992	(000000-)	Seat Kit, Suspension	1
	82343	(000000-)	Seat, Suspension	1

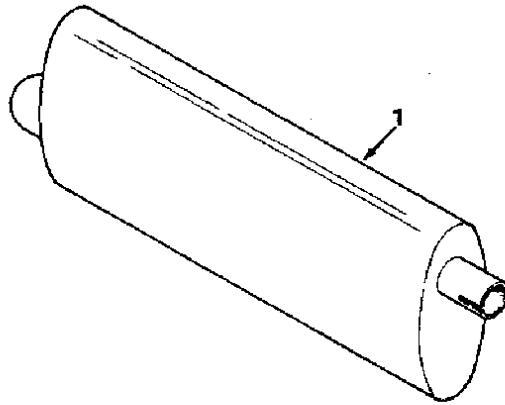

Fig. 48 - Spark Arresting Muffler Kit

02589

Key	Tennant® Part No.	Machine Serial Number	Description	Qty.
1	82652	(000000-)	Muffler, Spark Arresting	1

NOTE: To identify parts shown but not listed here, see Section 5, Low Dump Model Parts.

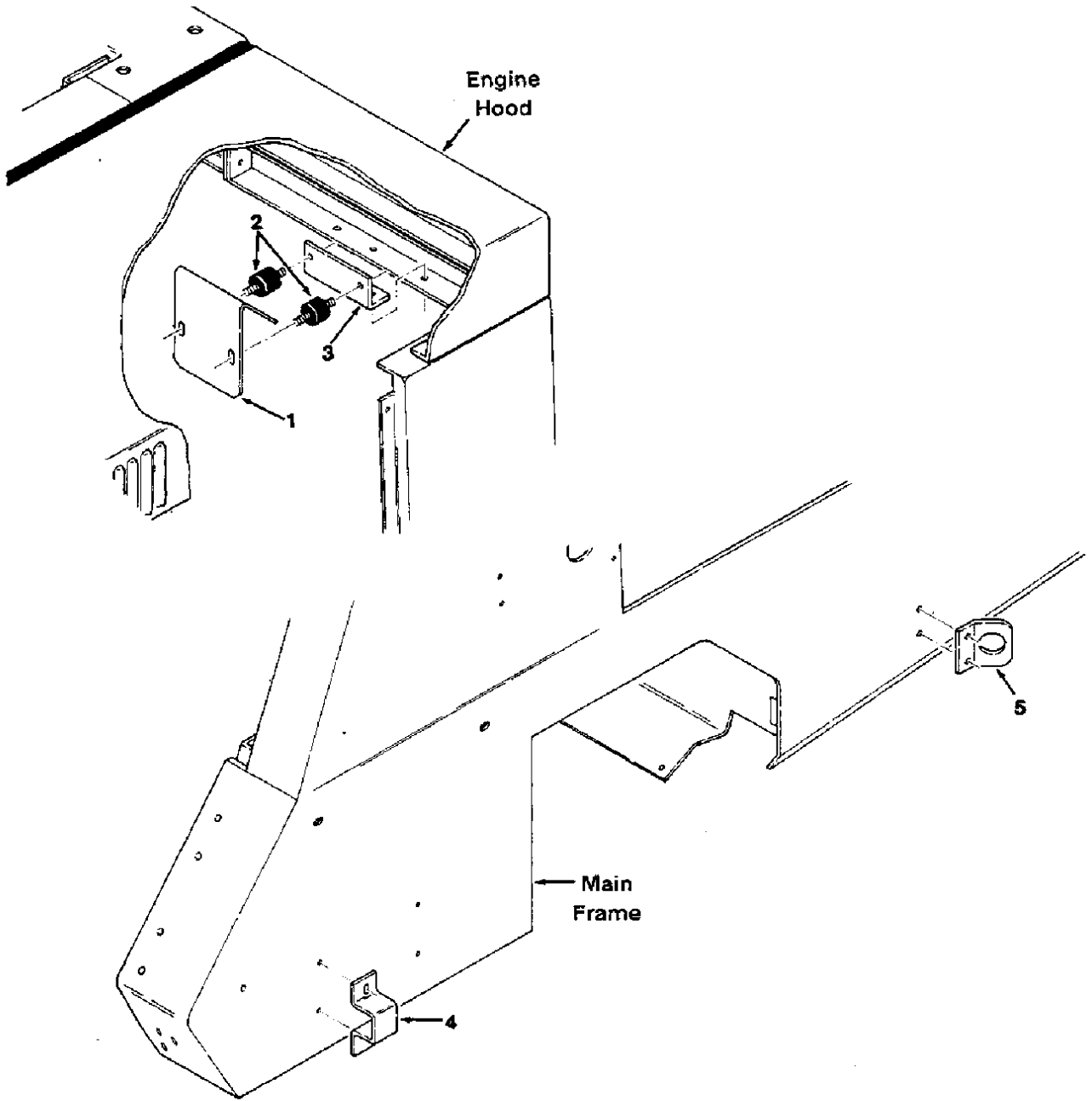

Fig. 49 - Hood Latch and Machine Tie-Down Kit

Key	Tennant® Part No.	Machine Serial Number	Description	Qty.
	82382	(000000-)	Tie-Down Kit, Hood Latch and Machine	1
1	82380	(000000-)	Latch, Engine Cover	1
2	82661	(000000-)	Isolator, Vibration	2
3	82381	(000000-)	Angle, Support	1
4	82195	(000000-)	Bracket, Front Tie-Down	2
5	82196	(000000-)	Bracket, Rear Tie-Down	2

NOTE: To identify parts shown but not listed here, see Section 5, Low Dump Model Parts.

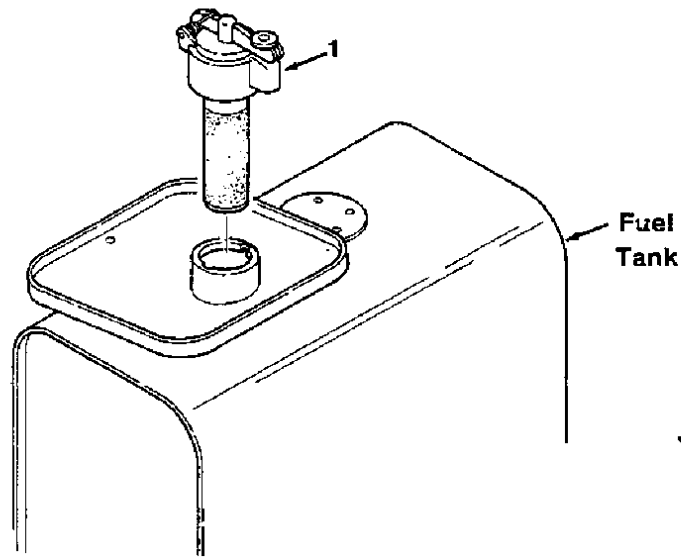

Fig. 50 - Protectoseal Fuel Tank Cap Kit

02550

Key	Tennant® Part No.	Machine Serial Number	Description	Qty.
1	02506-6	(000000-)	Cap, Protectoseal	1

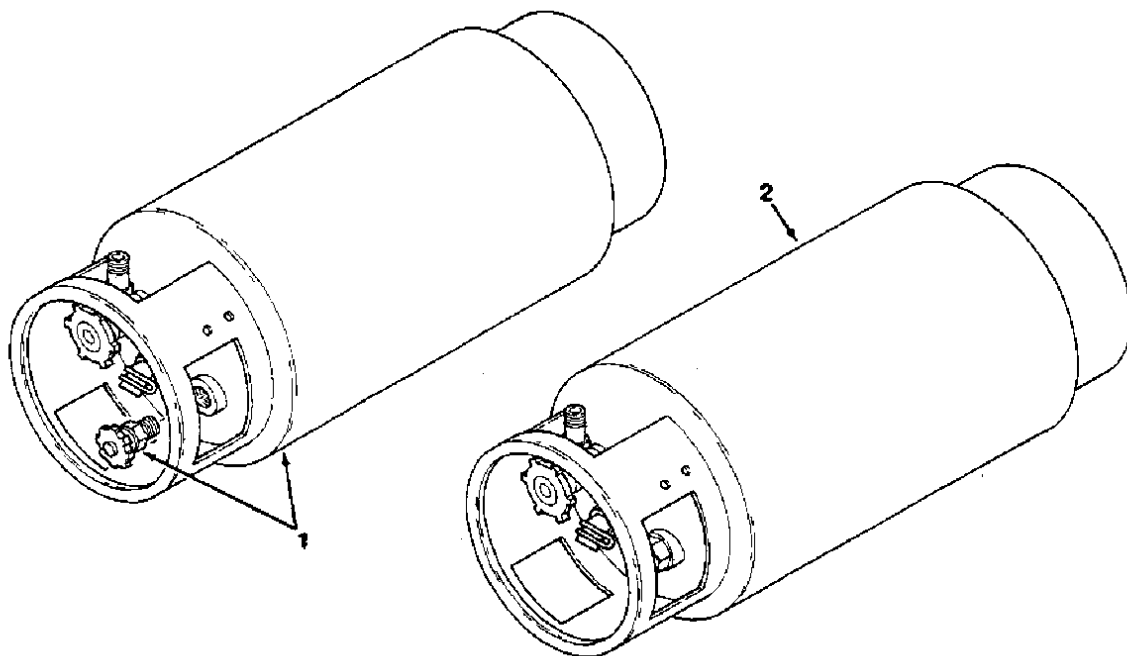

Fig. 51 - LPG Fuel Tanks Group

02574

Key	Tennant® Part No.	Machine Serial Number	Description	Qty.
1	24928-1	(000000-)	Tank, LPG, With Filler Valve	1
2	24928	(000000-)	Tank, LPG	1

NOTE: To identify parts shown but not listed here, see Section 5, Low Dump Model Parts.

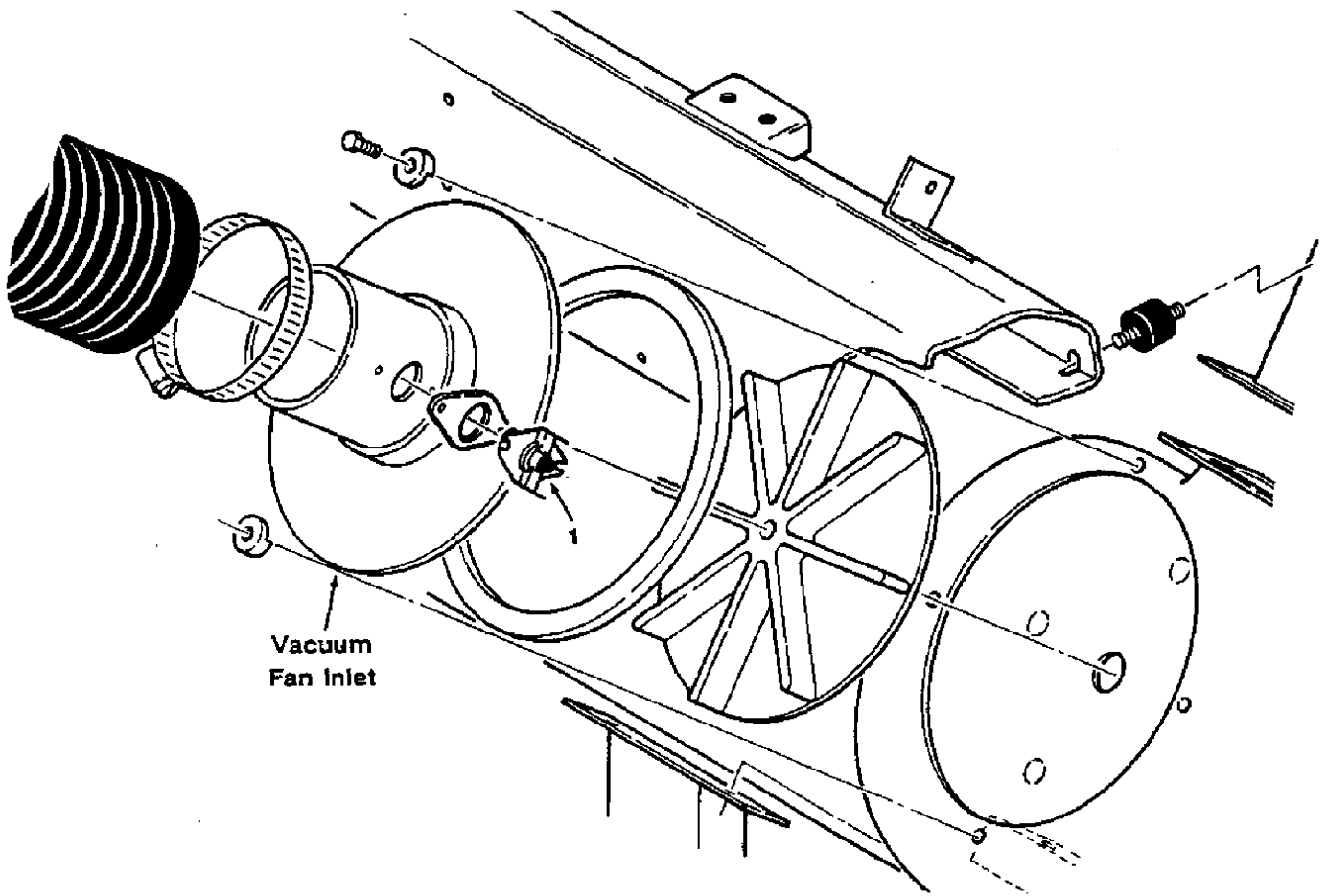

Fig. 52 - Thermostat Kit

03351

Key	Tennant® Part No.	Machine Serial Number	Description	Qty.
1	02957	(000000-)	Thermostat, Sealed, 155° F (68 ° C)	1

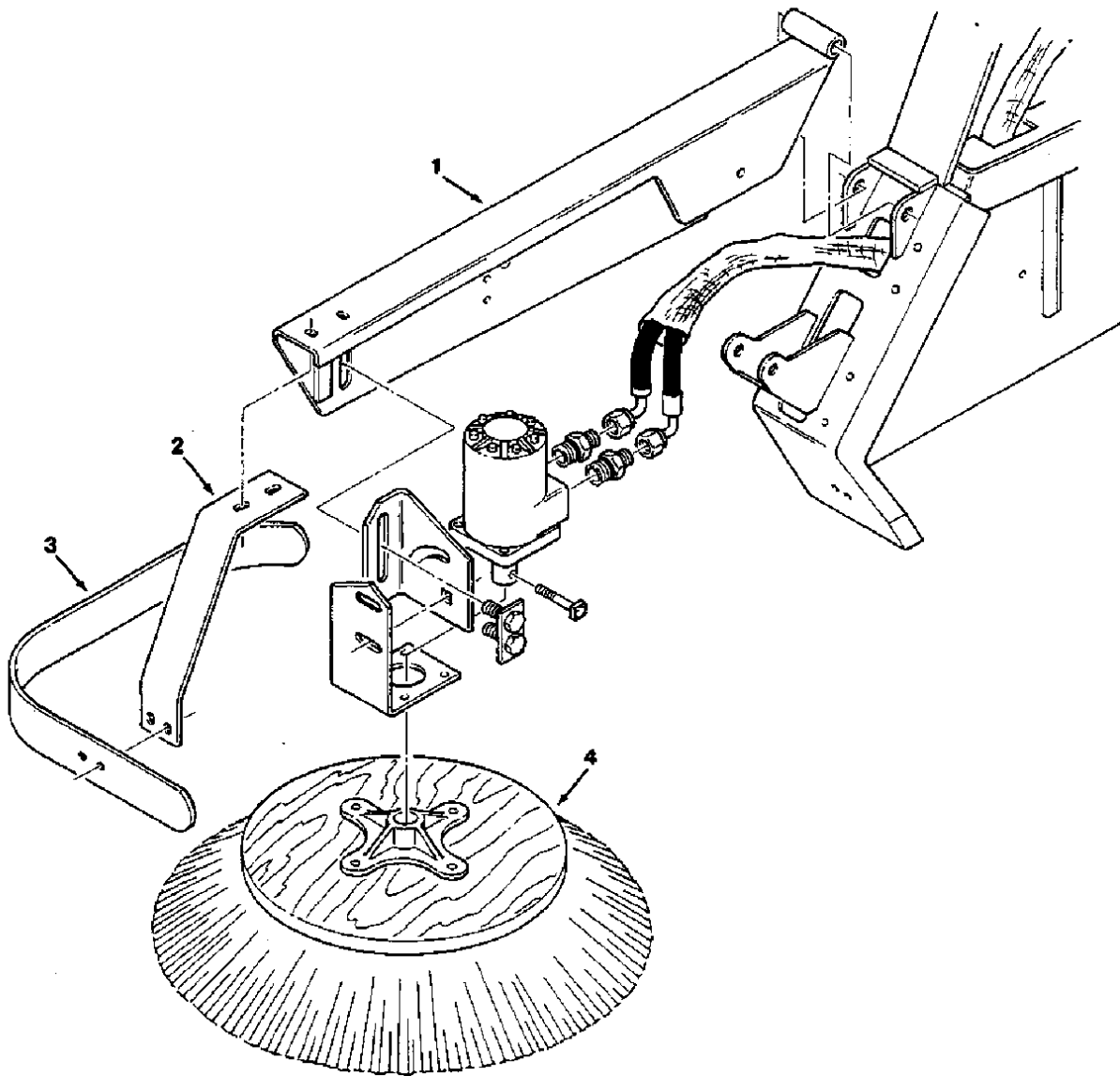

Fig. 53 - Extra Reach Side Brush Group Low Dump

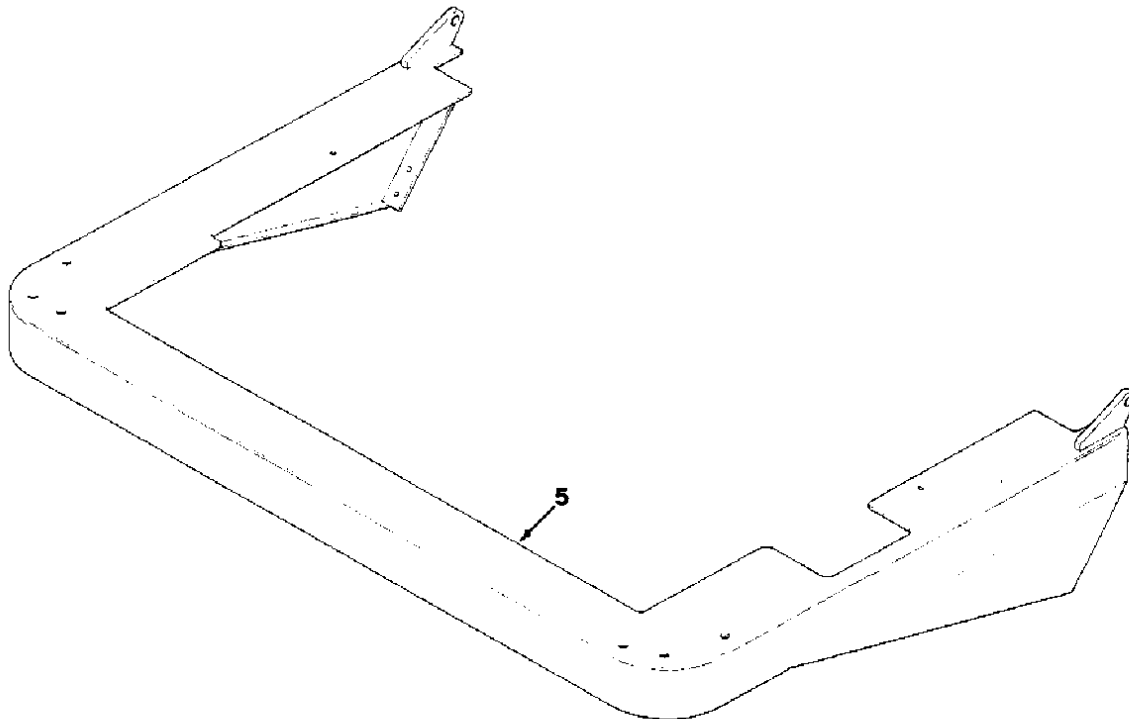

Fig. 53 - Extra Reach Side Brush Group Low Dump

03980

Key	Tennant® Part No.	Machine Serial Number	Description	Qty.
1	48062-1	(000000-)	Arm, Side Brush	1
2	08015	(000000-)	Support, Bumper Side Brush	1
3	08016	(000000-)	Bumper, Side Brush	1
4	08017	(000000-)	Side Brush Assembly	1
5	03022	(000000-)	Bumper, Front	1

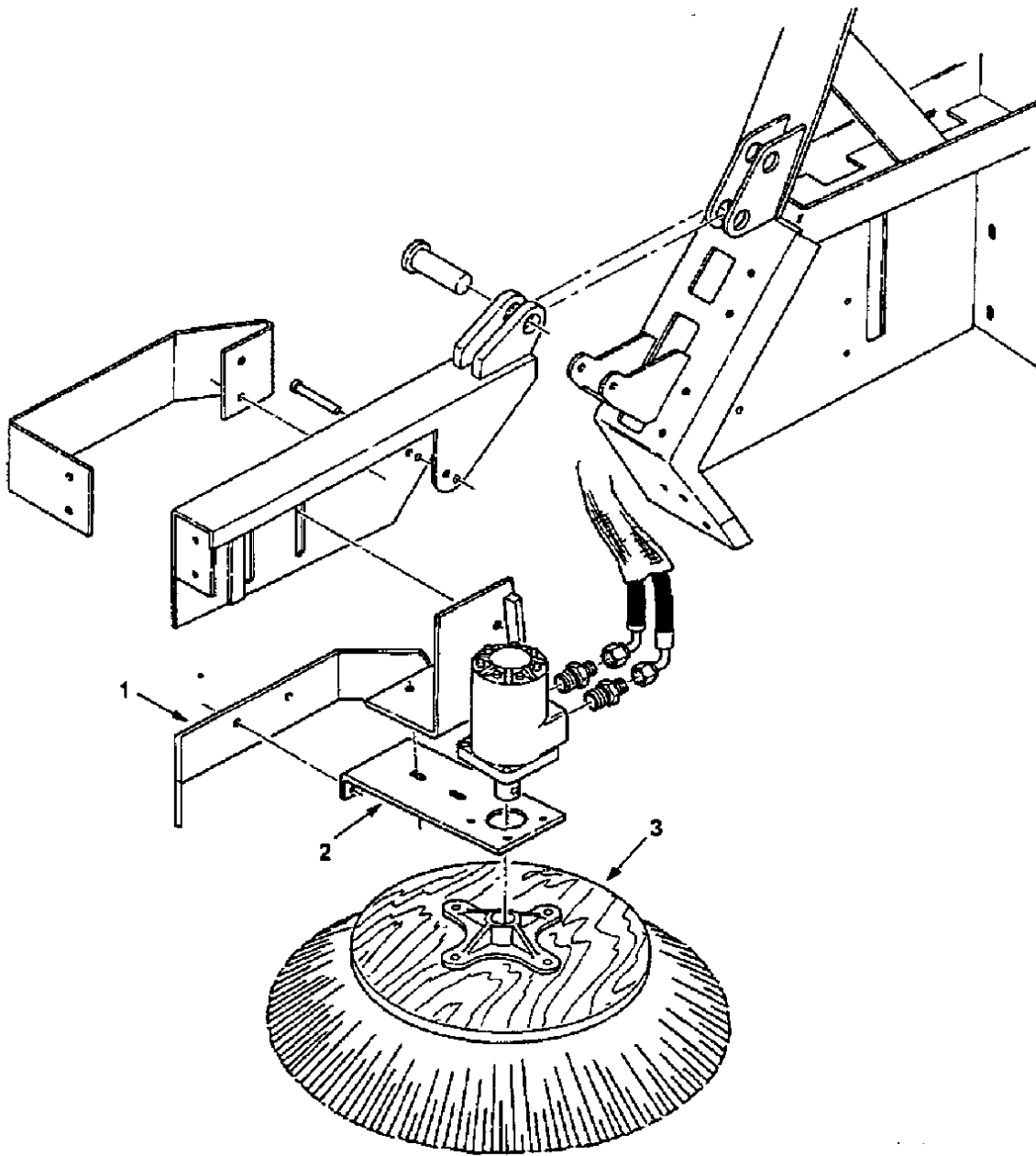

Fig. 54 - Extra Reach Side Brush Group Multi-Level Dump

04054

Key	Tennant® Part No.	Machine Serial Number	Description	Qty.
1	08007	(000000-)	Bumper, Side Brush	1
2	08008	(000000-)	Bracket, Side Brush Motor	1
3	08017	(000000-)	Side Brush Assembly	1

SECTION 12

HYDRAULIC COMPONENTS

CONTENTS

	Page
Ordering Repair Parts	12-1
Fig. 1 - Hydraulic Piston Pump Breakdown ..	12-2
Fig. 2 - Hydraulic Gear Pump Breakdown ..	12-4
Fig. 3 - Hydraulic Gear Pump Breakdown ..	12-5
Fig. 4 - Hydraulic Motor Breakdown	12-6
Fig. 5 - Hydraulic Motor Breakdown	12-7
Fig. 6 - Hydraulic Motor Breakdown	12-8
Fig. 7 - Hydraulic Motor Breakdown	12-9
Fig. 8 - Hydraulic Motor Breakdown	12-10
Fig. 9 - Hydraulic Motor Breakdown	12-11
Fig. 10 - Hydraulic Motor Breakdown	12-12
Fig. 11 - Hydraulic Valve Breakdown	12-13
Fig. 12 - Hydraulic Valve Breakdown	12-14
Fig. 13 - Hydraulic Solenoid Valve Breakdown	12-15
Fig. 14 - Hydraulic Cylinder Breakdown	12-16
Fig. 15 - Hydraulic Cylinder Breakdown	12-17
Fig. 16 - Hydraulic Cylinder Breakdown	12-18

NOTE: Section 12, Hydraulic Components, lists repair parts for every repairable hydraulic component.

ORDERING REPAIR PARTS

The components used in this machine have been carefully selected for performance and safety. Use only Tennant Company specified or equivalent parts.

To receive prompt service in filling of your parts orders, please direct all orders for parts with Tennant Company part numbers to the Tennant Company, and all orders for parts with vendor part numbers to the local supplier of the respective vendor.

When ordering parts, please furnish all of the following information:

1. Machine model number - shown on the machine data plate.

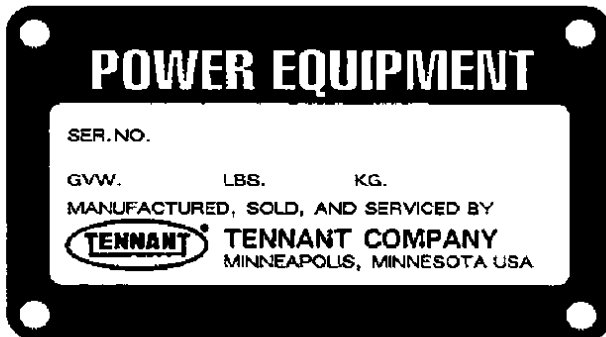

2. Machine serial number - shown on the machine data plate.
3. Engine type - gasoline, LPG, diesel, electric.
4. Company name.
5. Shipping address.
6. Billing address.
7. Name, first and last - of person ordering parts.
8. Telephone number.
9. Purchase order number.
10. Part number, description, and quantity - of each item on the order.

Do not order parts by key number or the figure number of the illustrated parts. Indented items indicate parts of assemblies. Standard hardware is furnished only when part of a purchased assembly. Please get hardware from a local hardware supplier.

If the old part cannot be identified, send it to us with the quantity needed specified on the order.

Any claim for loss or damage to a shipment in transit should be filed promptly against the transportation company making the delivery. Shipments will be complete unless the packing list or order acknowledgement indicate items back ordered.

If parts received are suspected to be incorrect or defective, please write, wire, or phone the Tennant Company representative from whom you ordered the part. They will give authorization for return and/or handle replacement shipments when required.

SERIAL NUMBER INFORMATION EXPLANATION

Serial number listings are shown to indicate on which machines each part can be used. These listings are explained by the following examples:

(000000-) The part can be used on all machines.

(003342-) The part can be used on all machines beginning with the serial number listed.

(000000-004320) The part can be used on all machines up to and including serial number listed.

(004321-005678) The part can be used on all machines between and including the serial numbers listed.

Where xxxxx's are listed in place of a serial number, it indicates a change was made but the exact serial number had not been established when the catalog went to press.

SI UNITS OF MEASURE (INTERNATIONAL SYSTEM)

Metric equivalents have been included, where applicable, throughout this parts catalog.

FASTENER STRENGTH IDENTIFICATION

Fasteners required to have high-strength qualities equivalent to SAE Grade 8 are identified throughout this catalog by the description GR 8. Unless identified by this description, all standard fasteners are SAE Grade 5.

(Specifications and design subject to change without notice.)

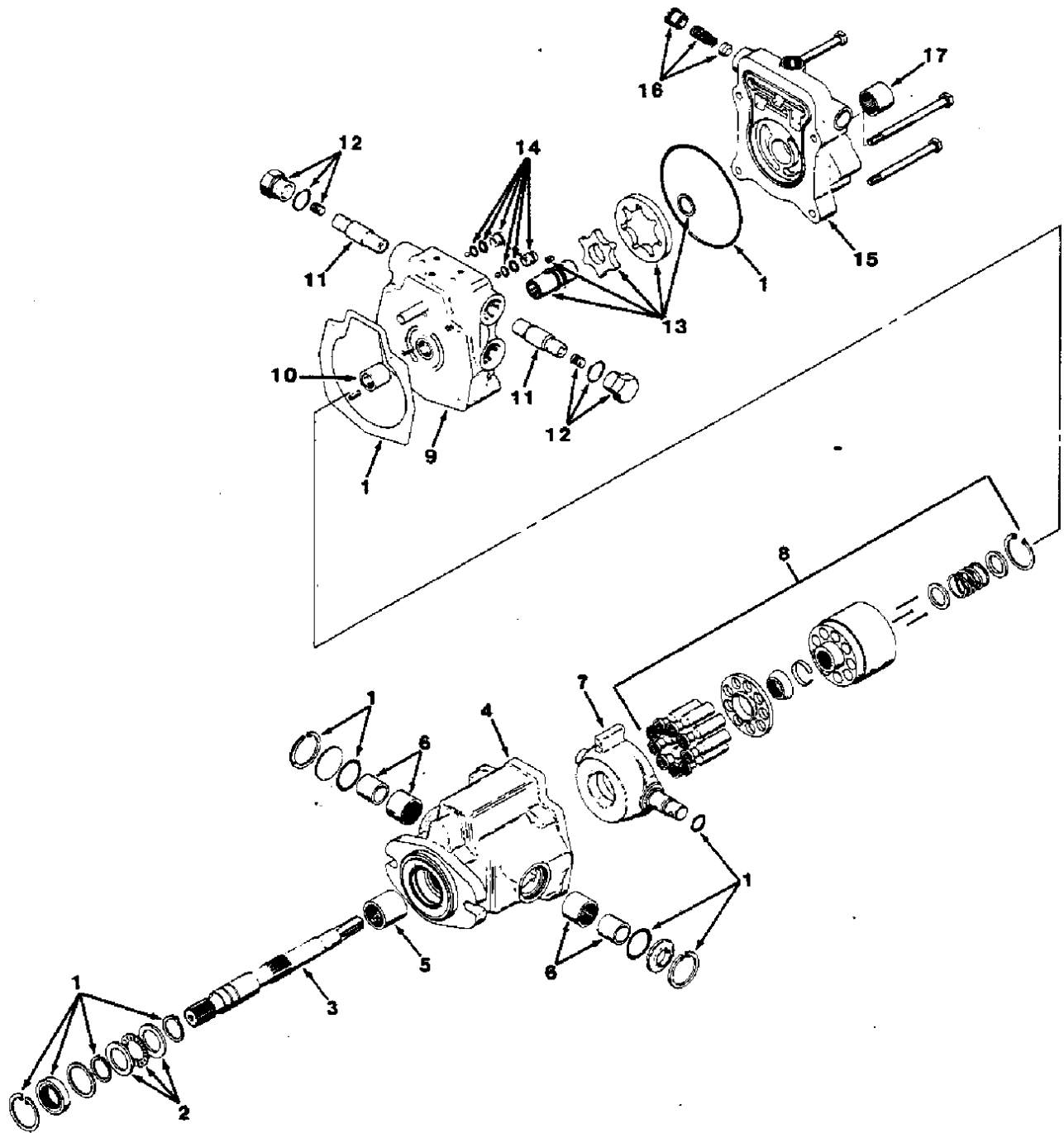

Fig. 1 - Hydraulic Piston Pump Breakdown

Fig. 1 - Hydraulic Piston Pump Breakdown

02957

Key	Tennant® Part No.	Machine Serial Number	Description	Qty.
1	02633	(000000-)	Pump, Hydraulic	1
2	55918	(000000-)	Seal Kit	1
3	55922	(000000-)	Bearing Kit, Thrust	1
3	55931	(000000-)	Shaft, Pump	1
4	58925	(000000-)	Housing Assembly, Pump	1
5	55939	(000000-)	Bearing, Roller	1
6	55905	(000000-)	Bearing, Trunnion	2
7	55933	(000000-)	Plate, Cam	1
8	55920	(000000-)	Rotating Kit	1
9	57051	(000000-)	Back Plate	1
10	55937	(000000-)	Bearing, Roller	1
11	02650	(000000-)	Valve, Relief	2
12	57210	(000000-)	Plug Assembly	2
13	55932	(000000-)	Gerotor and Coupler Assembly	1
14	37457	(000000-)	Valve Assembly	2
15	55930	(000000-)	Pump Adaptor Assembly	1
16	55906	(000000-)	Valve, Charge Relief	1
17	55929	(000000-)	Bearing, Roller	1

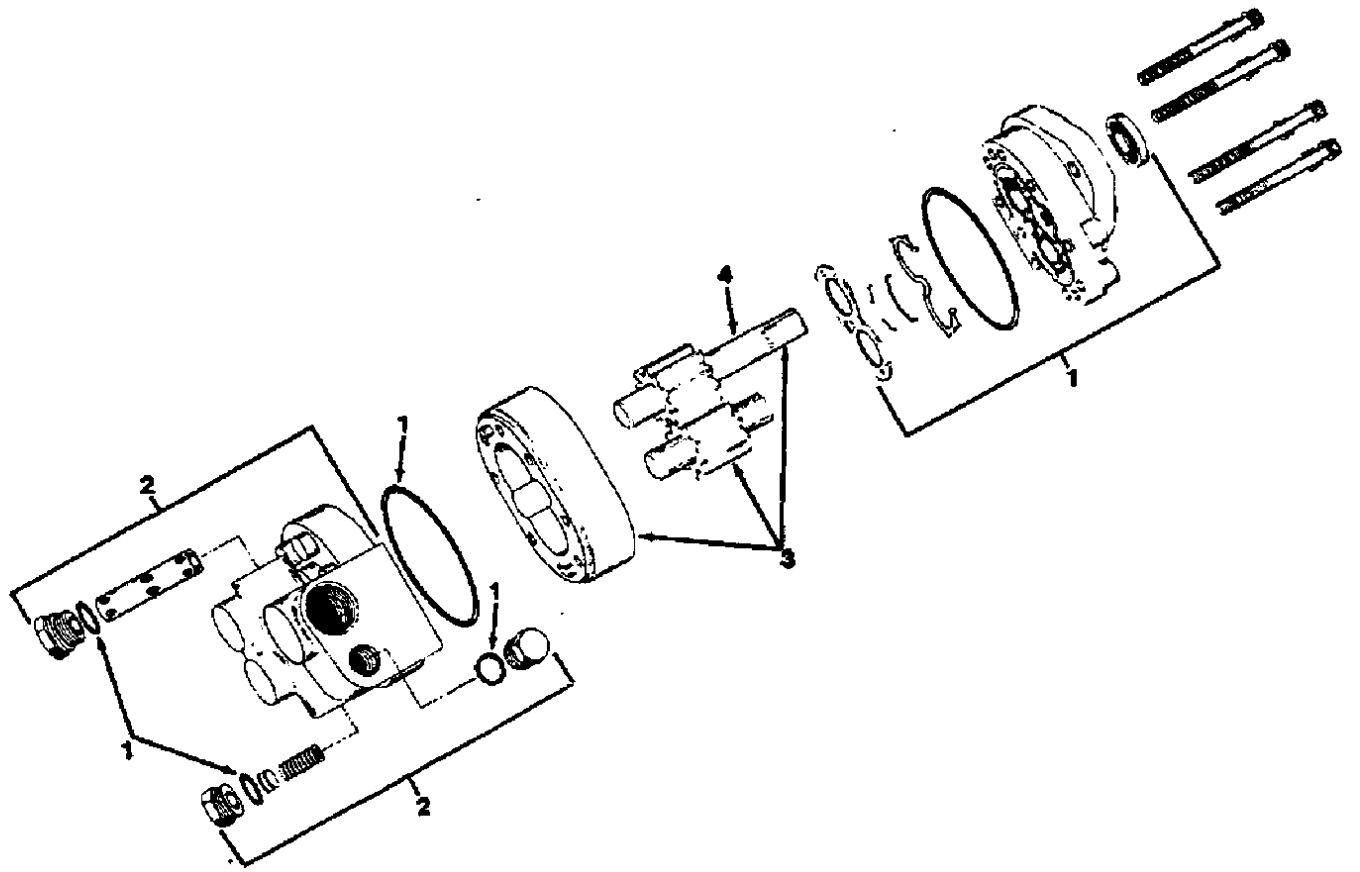

Fig. 2 - Hydraulic Gear Pump Breakdown

04616

Key	Tennant® Part No.	Machine Serial Number	Description	Qty.
	82205	(000000-003274)	Pump, Hydraulic Gear	1
1	57064	(000000-003274)	Seal Kit	1
2	82333	(000000-003274)	Back Plate Kit	1
3	02602	(000000-003274)	Gear and Body Kit	1
4	02605	(000000-003274)	Drive	1

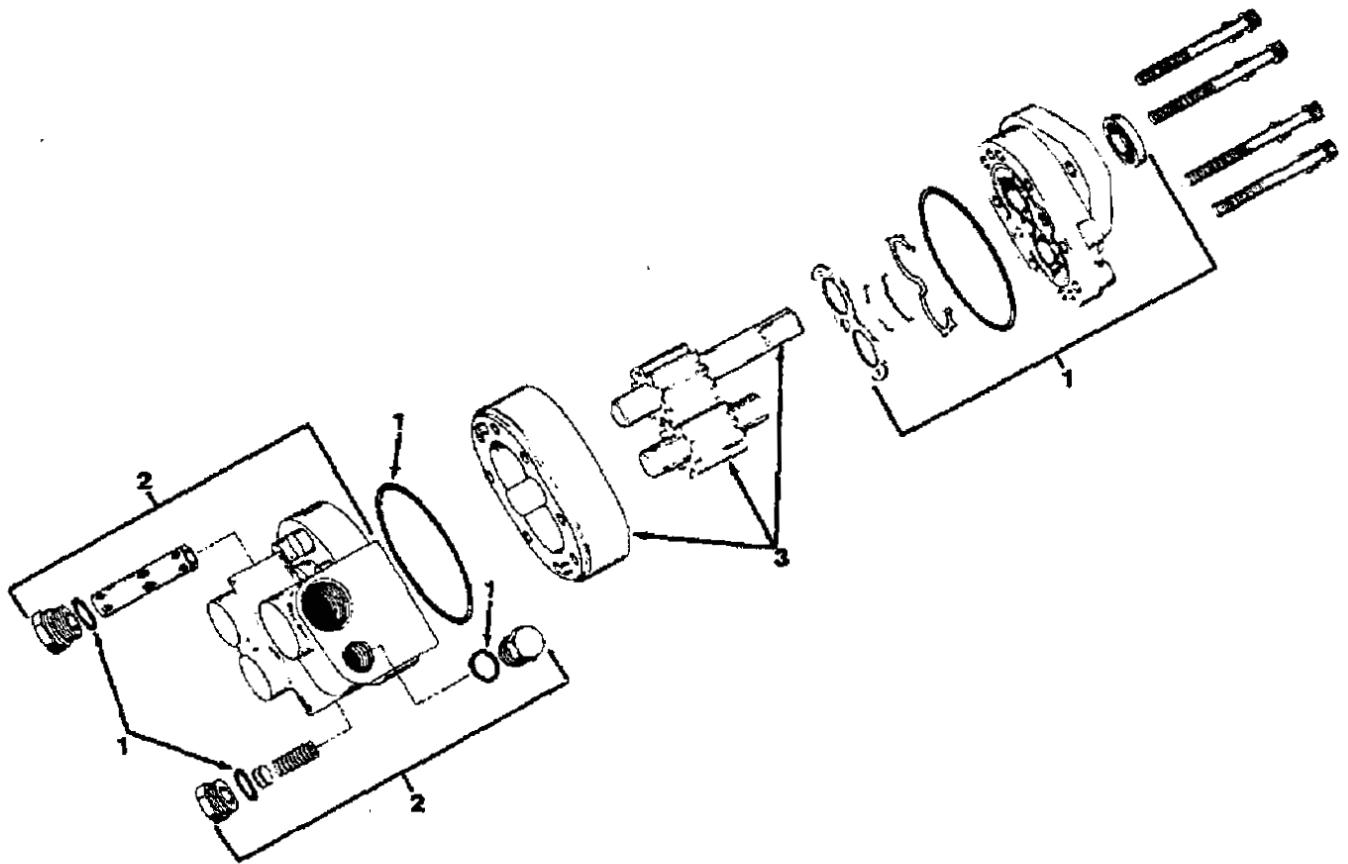

Fig. 3 - Hydraulic Gear Pump Breakdown

04617

Key	Tennant® Part No.	Machine Serial Number	Description	Qty.
	82205	(003275-)	Pump, Hydraulic Gear	1
1	57064	(003275-)	Seal Kit	1
2	82333	(003275-)	Back Plate Kit	1
3	02602	(003275-)	Gear and Body Kit	1

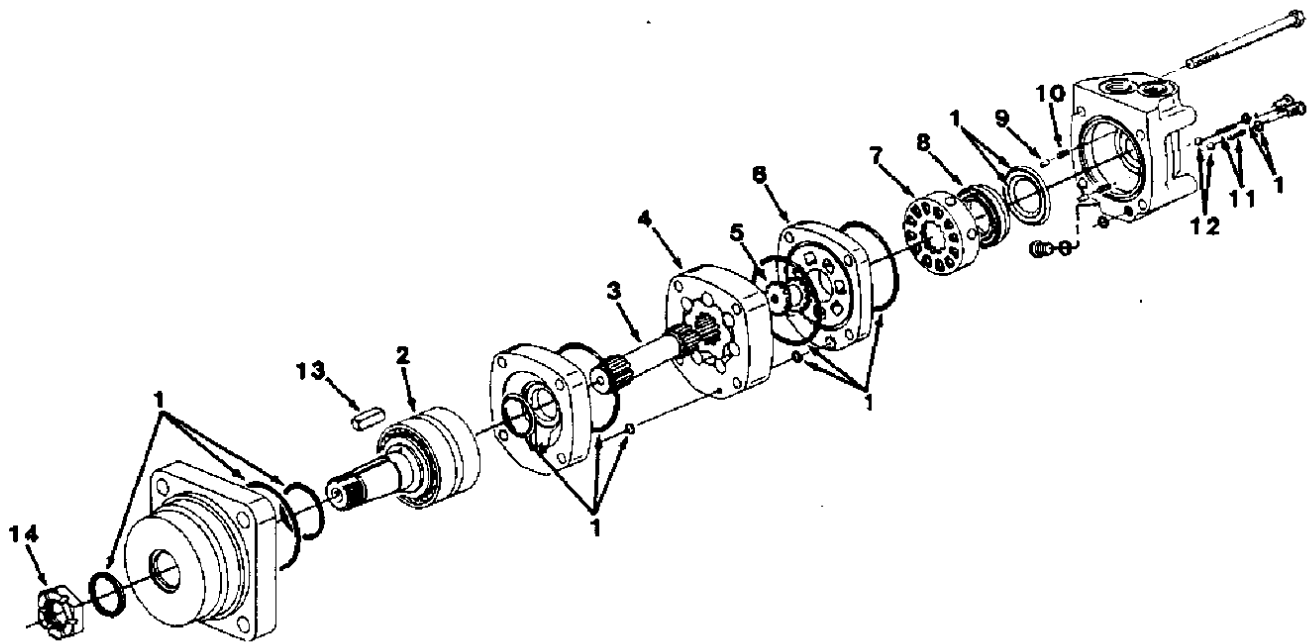

Fig. 4 - Hydraulic Motor Breakdown

03457

Key	Tennant® Part No.	Machine Serial Number	Description	Qty.
	82750	(000000-002229)	Motor, Hydraulic	1
1	33837	(000000-002229)	Seal Kit	1
2	57367	(000000-002229)	Shaft and Bearing Kit	1
3	02603	(000000-002229)	Drive	1
4	02604	(000000-002229)	Geroler	1
5	57370	(000000-002229)	Drive, Valve	1
6	57371	(000000-002229)	Plate, Valve	1
7	57372	(000000-002229)	Valve	1
8	57373	(000000-002229)	Ring, Balance	1
9	57374	(000000-002229)	Pin	2
10	57375	(000000-002229)	Spring	2
11	34179	(000000-002229)	Spring	2
12	37766	(000000-002229)	Ball	2
	38315	(000000-002229)	Key	1
13	38490	(000000-002229)	Nut	1
14				

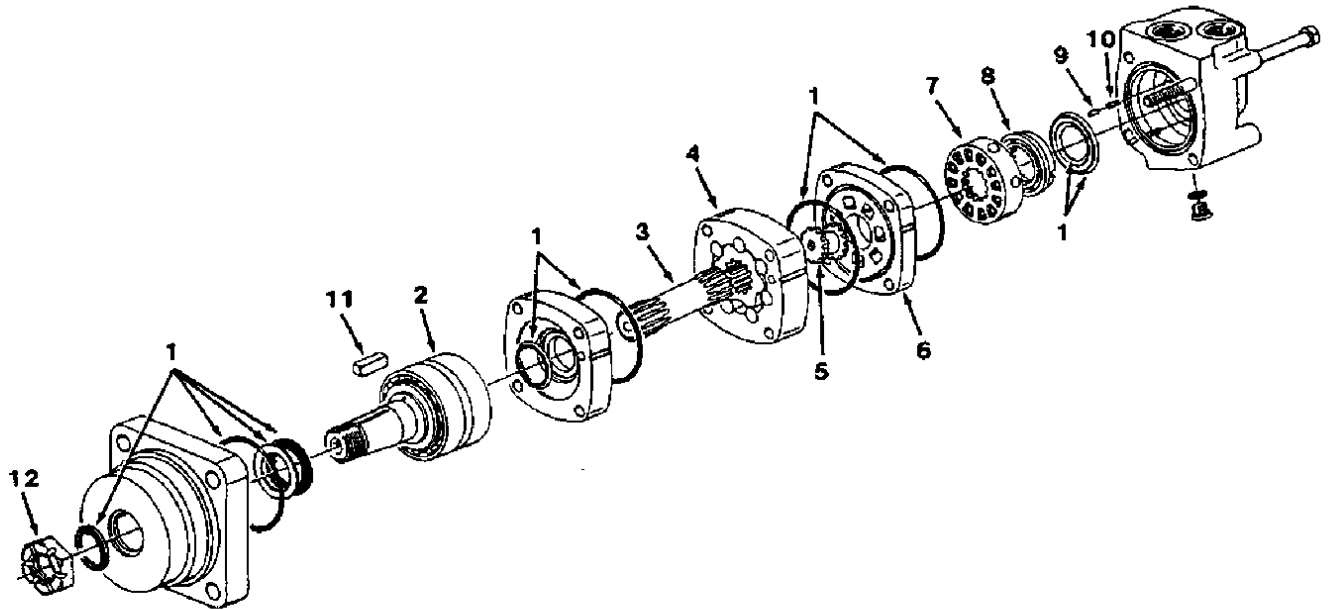

Fig. 5 - Hydraulic Motor Breakdown

03456

Key	Tennant® Part No.	Machine Serial Number	Description	Qty.
	02641	(002230-)	Motor, Hydraulic	1
1	02643	(002230-)	Seal Kit	1
2	02644	(002230-)	Shaft and Bearing Kit	1
3	02603	(002230-)	Drive	1
4	02645	(002230-)	Geroler	1
5	57370	(002230-)	Valve Drive	1
6	02646	(002230-)	Valve Plate	1
7	02647	(002230-)	Valve	1
8	57373	(002230-)	Balance Ring	1
9	57374	(002230-)	Pin	2
10	57375	(002230-)	Spring	2
11	38315	(002230-)	Key	1
12	38490	(002230-)	Nut	1

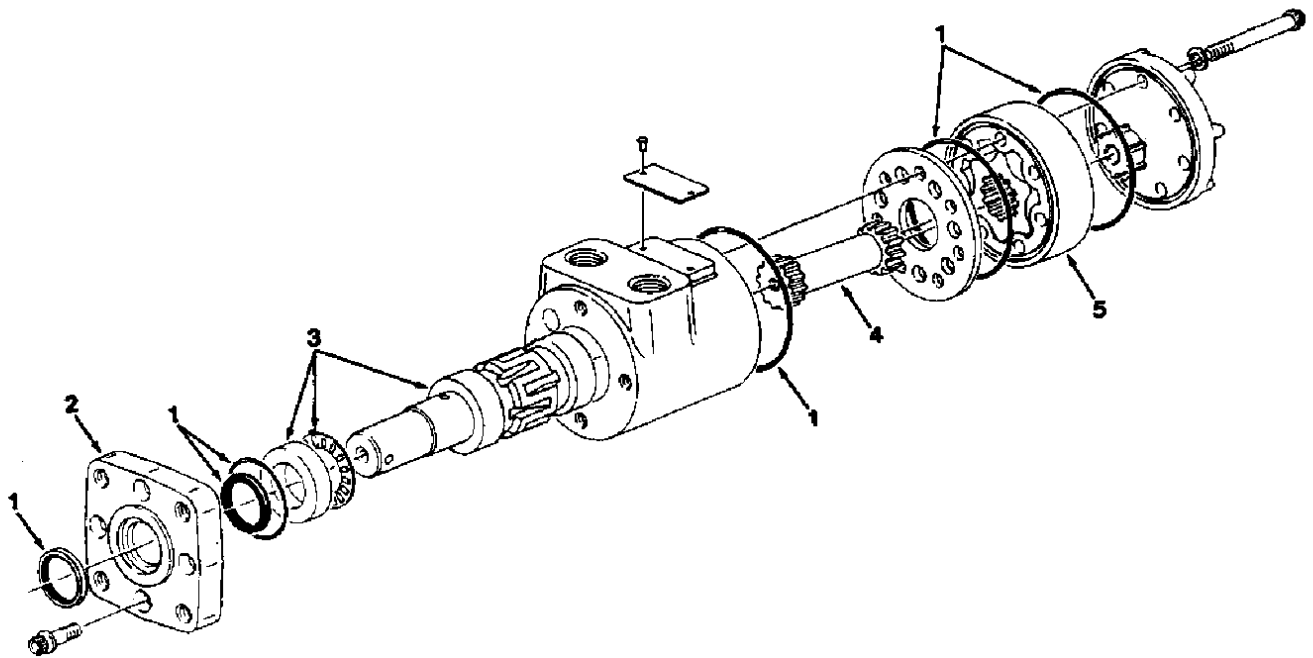

Fig. 6 - Hydraulic Motor Breakdown

01856

Key	Tennant® Part No.	Machine Serial Number	Description	Qty.
	34423	(000000-)	Motor, Hydraulic	1
1	47649	(000000-)	Seal Kit	1
2	34174	(000000-)	Flange, Mounting	1
3	34175	(000000-)	Shaft Assembly, Output	1
4	34176	(000000-)	Drive	1
5	34177	(000000-)	Gerotor Set	1

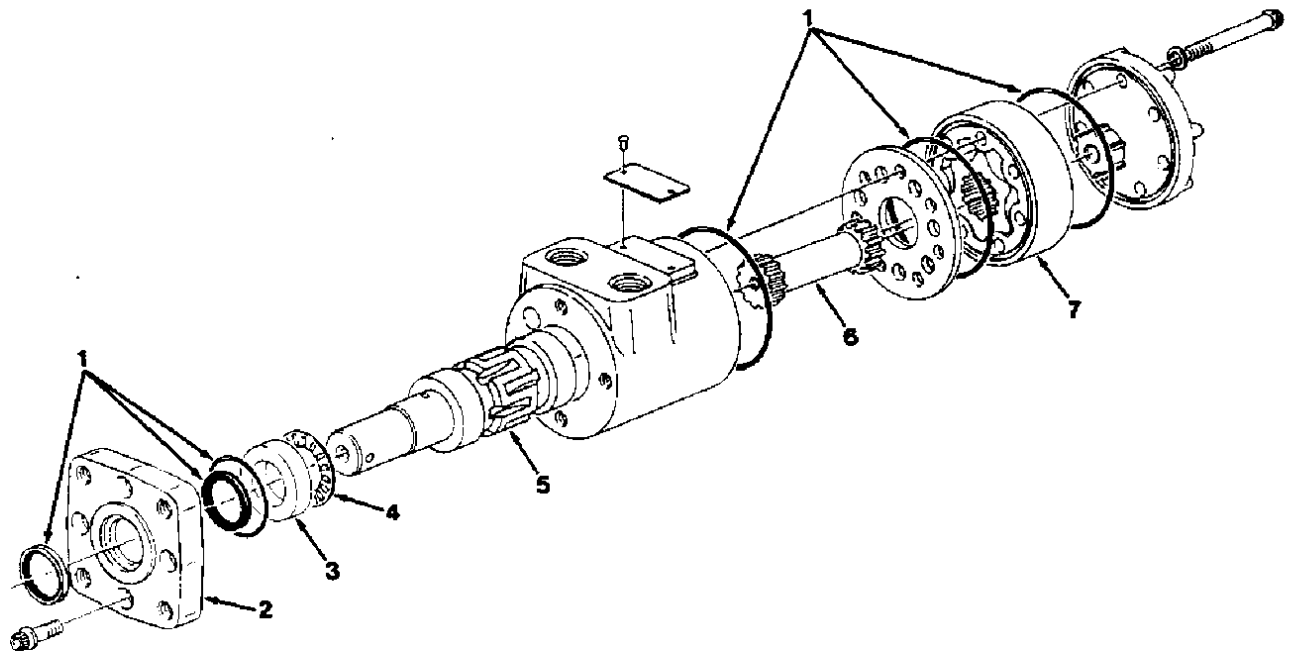

Fig. 7 - Hydraulic Motor Breakdown

02612

Key	Tennant® Part No.	Machine Serial Number	Description	Qty.
1	82758	(000000-)	Motor, Hydraulic	1
	47649	(000000-)	Seal Kit	1
2	34174	(000000-)	Flange	1
3	16695	(000000-)	Race, Thrust	1
4	45628	(000000-)	Bearing, Thrust	1
5	57282	(000000-)	Shaft, Output	1
6	34176	(000000-)	Drive	1
7	57961	(000000-)	Gerotor	1

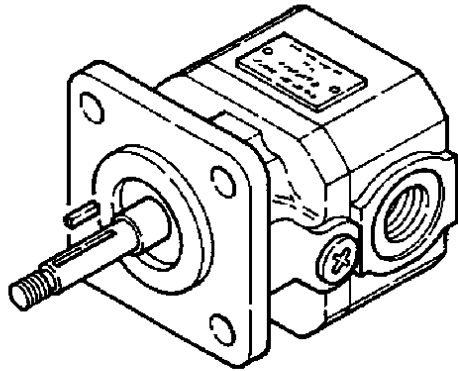

Fig. 8 - Hydraulic Motor Breakdown

02613

Key	Tennant® Part No.	Machine Serial Number	Description	Qty.
	77101	(000000-)	Motor, Hydraulic	1
	SK2561	(000000-)	Seal Kit	1
	00966	(000000-)	Key	1

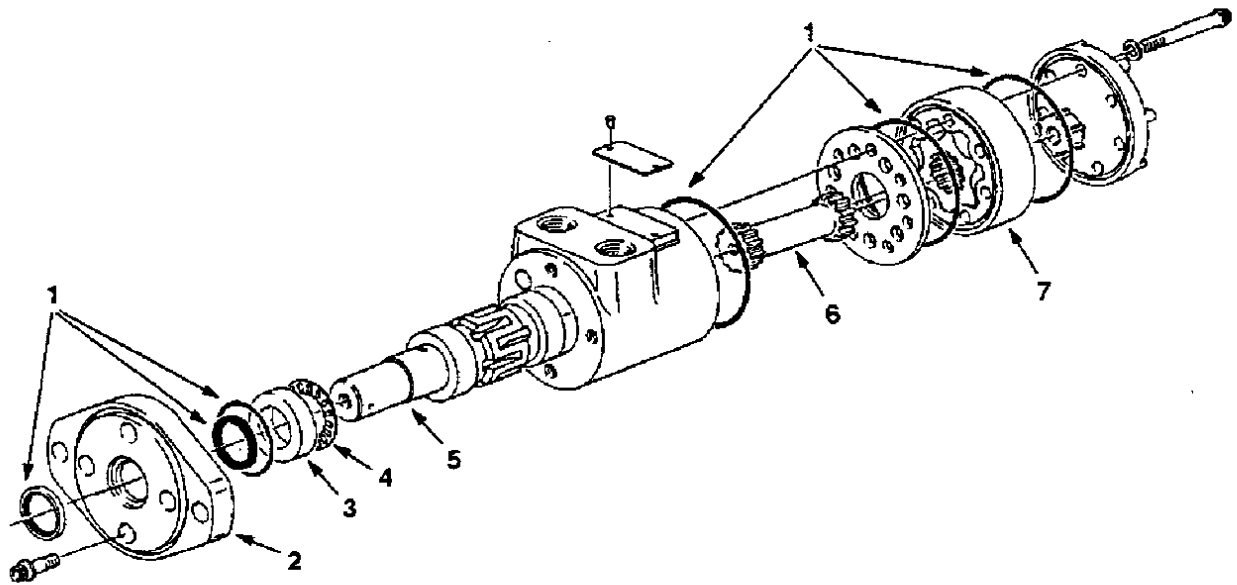

Fig. 9 - Hydraulic Motor Breakdown

02800

Key	Tennant® Part No.	Machine Serial Number	Description	Qty.
	33795	(000000-)	Motor, Hydraulic	1
1	47649	(000000-)	Seal Kit	1
2	38645	(000000-)	Flange, Mounting	1
3	16695	(000000-)	Race	1
4	45628	(000000-)	Bearing	1
5	02630	(000000-)	Shaft	1
6	34176	(000000-)	Drive	1
7	34177	(000000-)	Gerotor Assembly	1

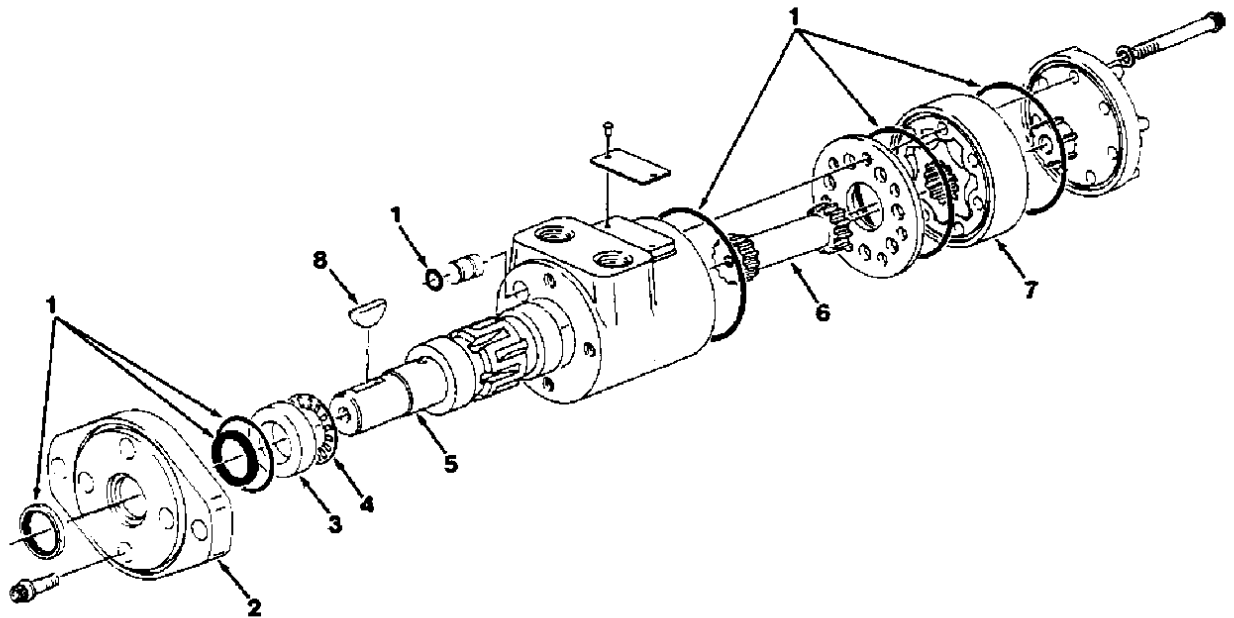

Fig. 10 – Hydraulic Motor Breakdown

02799

Key	Tennant® Part No.	Machine Serial Number	Description	Qty.
	47650-9	(000000-)	Motor, Hydraulic	1
1	47649	(000000-)	Seal Kit	1
2	34174	(000000-)	Flange, Mounting	1
3	16695	(000000-)	Race	1
4	45628	(000000-)	Bearing	1
5	02631	(000000-)	Shaft	1
6	34172	(000000-)	Drive	1
7	57542	(000000-)	Gerotor Assembly	1
8	00500-15	(000000-)	Key, Woodruff	1

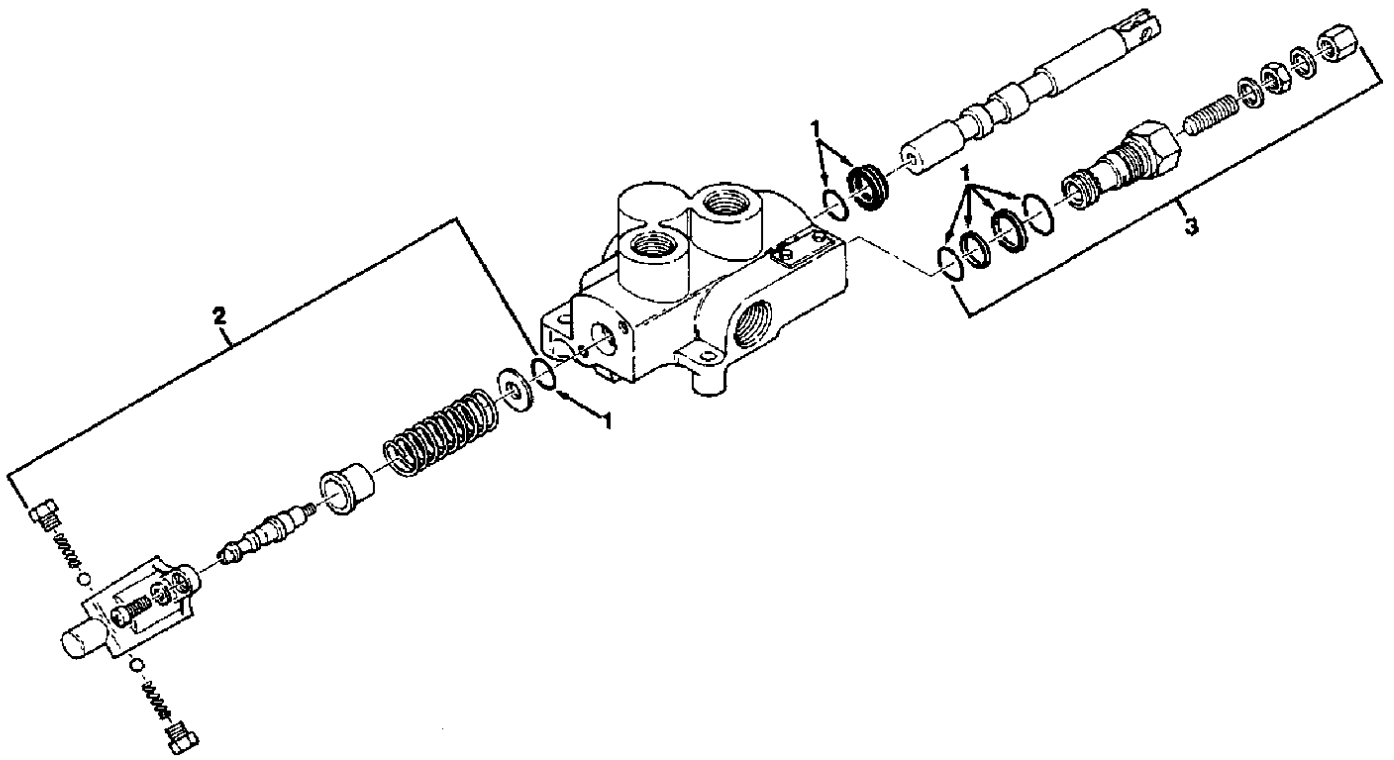

Fig. 11 - Hydraulic Valve Breakdown

02581

Key	Tennant® Part No.	Machine Serial Number	Description	Qty.
	62550	(000000-)	Valve, Hydraulic	1
1	01666	(000000-)	Seal Kit	1
2	01669	(000000-)	Detent Kit	1
3	01817	(000000-)	Relief Assembly	1

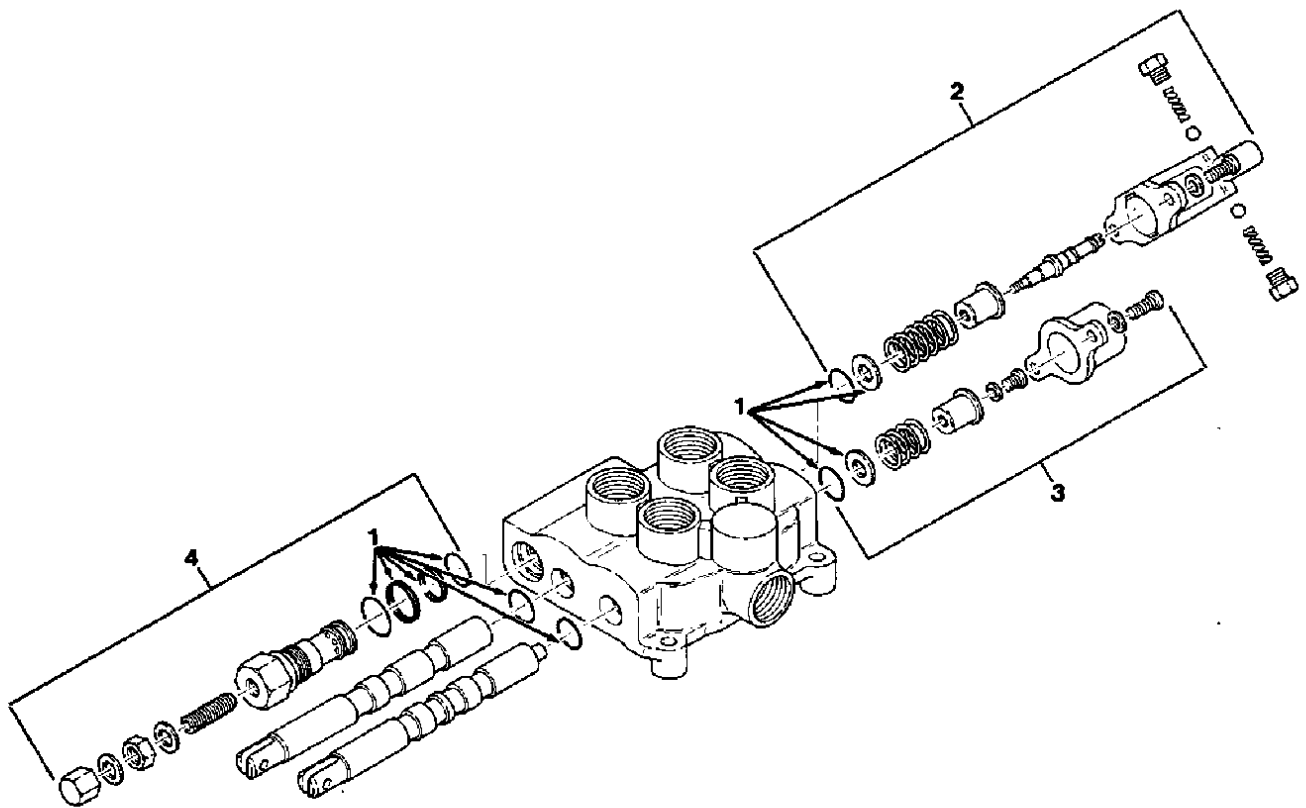

Fig. 12 - Hydraulic Valve Breakdown

02563

Key	Tennant® Part No.	Machine Serial Number	Description	Qty.
	34319	(000000-)	Valve, Hydraulic	1
1	01666	(000000-)	Seal Kit	1
2	01669	(000000-)	Detent Kit	1
3	01673	(000000-)	Spring Kit, Centering	1
4	01818	(000000-)	Relief Assembly	1

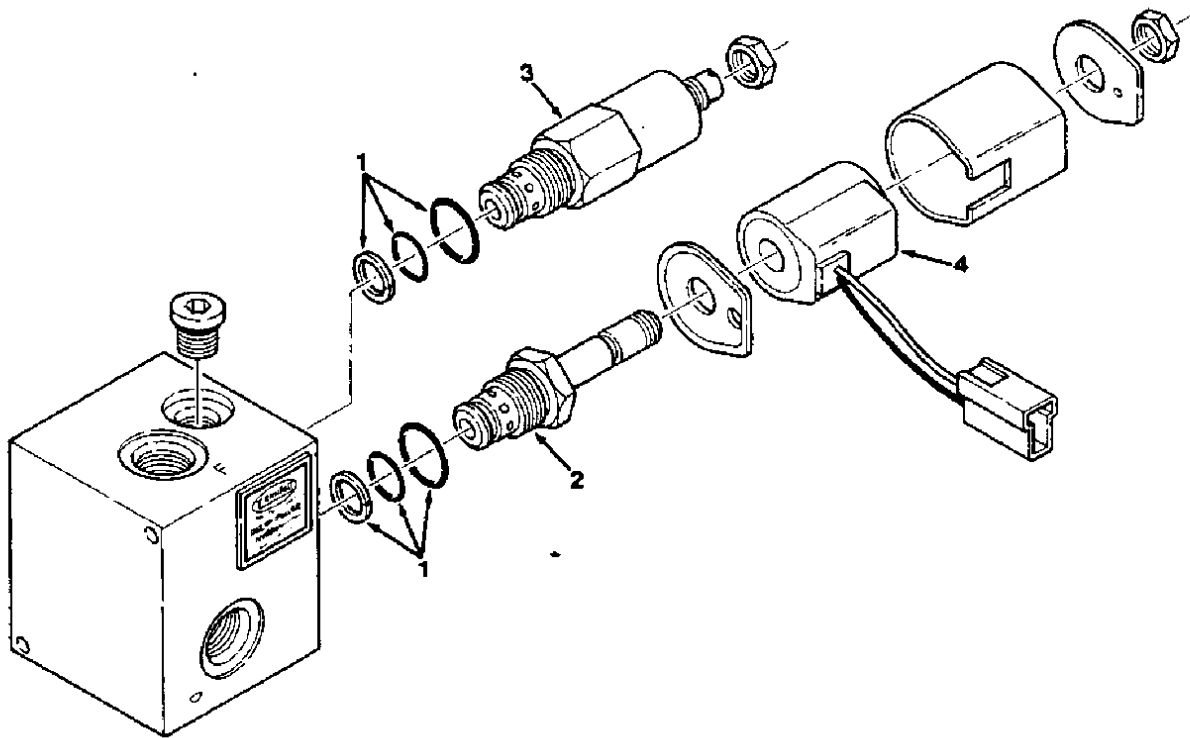

Fig. 13 - Hydraulic Solenoid Valve Breakdown

02580

Key	Tennant® Part No.	Machine Serial Number	Description	Qty.
	82754	(000000-)	Valve, Solenoid	1
1	02606	(000000-)	Seal Kit	1
2	02607	(000000-)	Valve, Cartridge	1
3	02609	(000000-)	Valve, Relief	1
4	57186	(000000-)	Solenoid	1

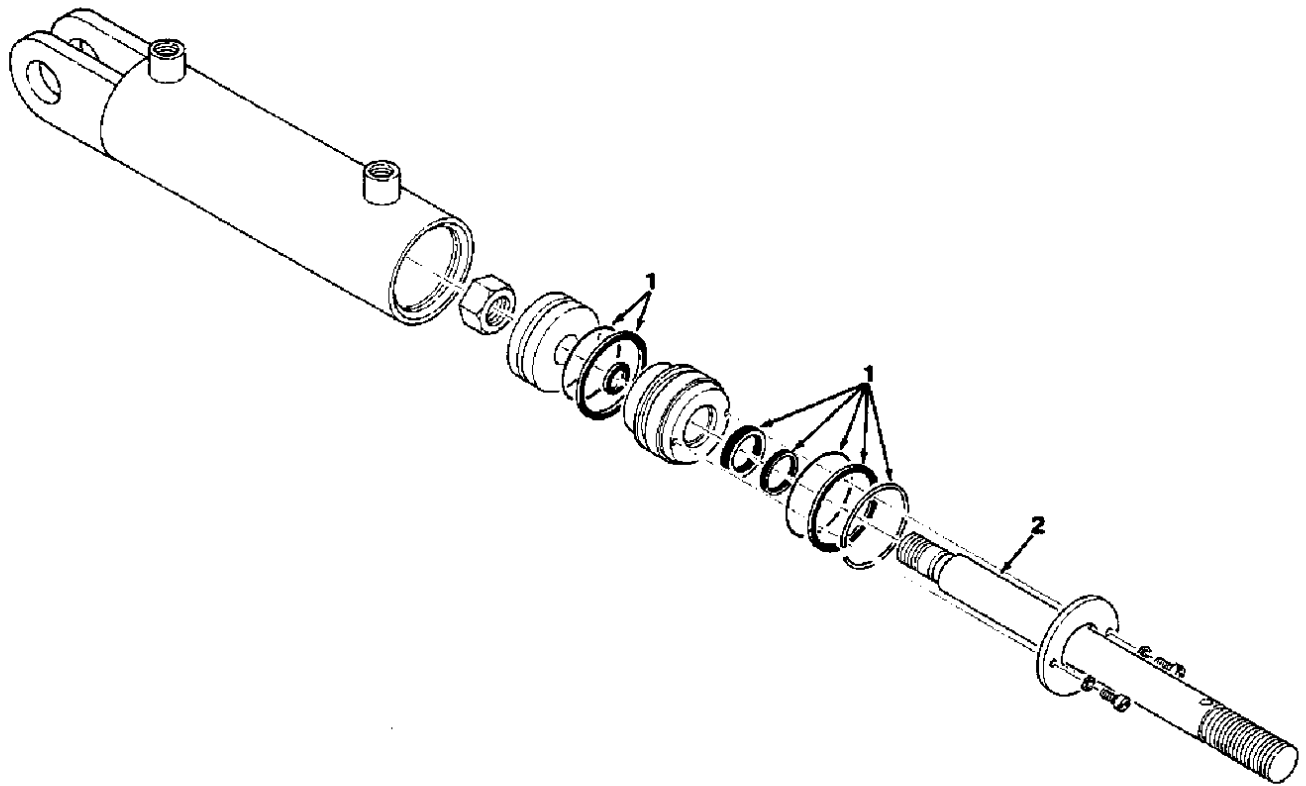

Fig. 14 - Hydraulic Cylinder Breakdown

Key	Tennant® Part No.	Machine Serial Number	Description	Qty.
1	82755 02610	(000000-) (000000-)	Cylinder, Hydraulic Seal Kit	1 1

02609

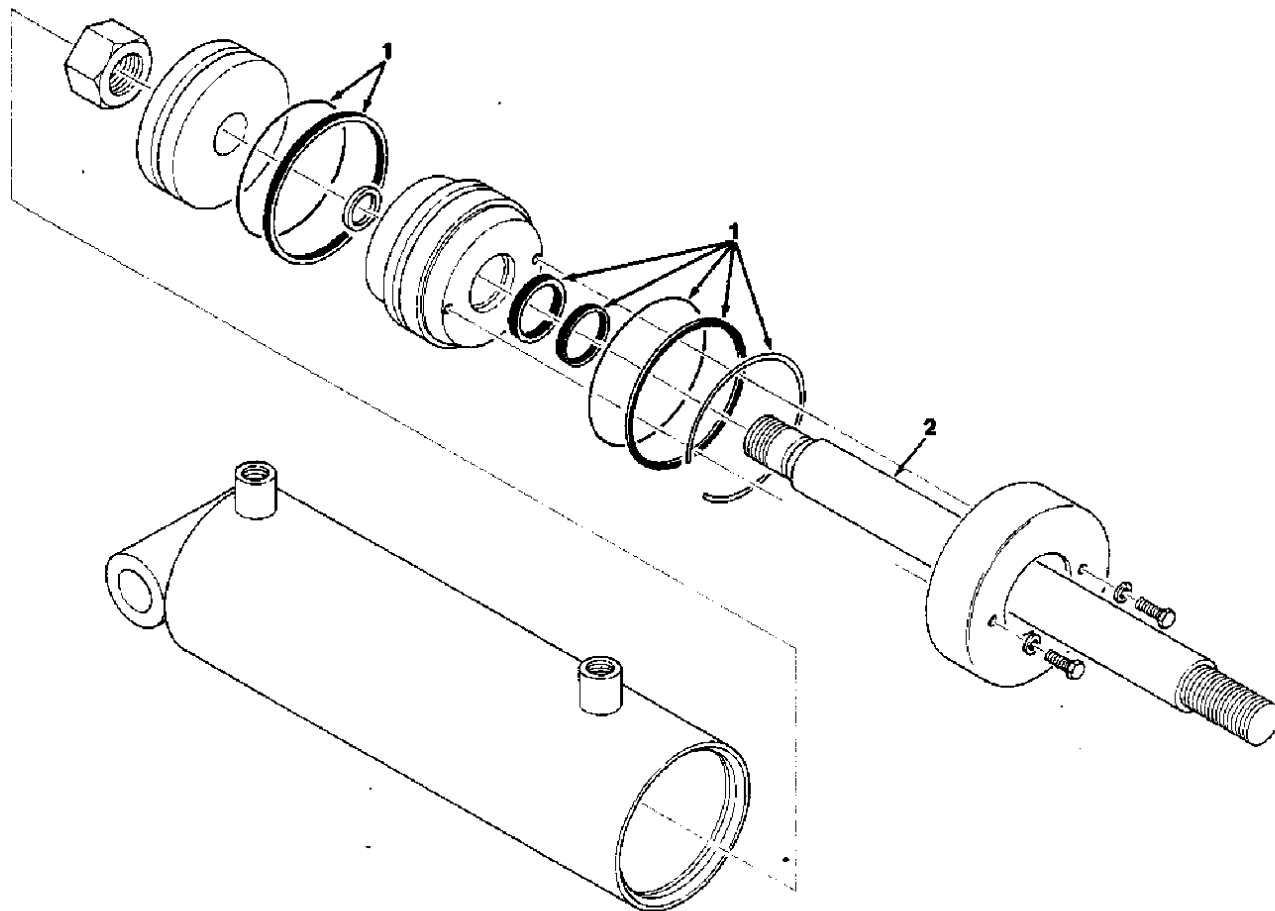

Fig. 15 - Hydraulic Cylinder Breakdown

02608

Key	Tennant® Part No.	Machine Serial Number	Description	Qty.
1	82757	(000000-)	Cylinder, Hydraulic	1
	02612	(000000-)	Seal Kit	1

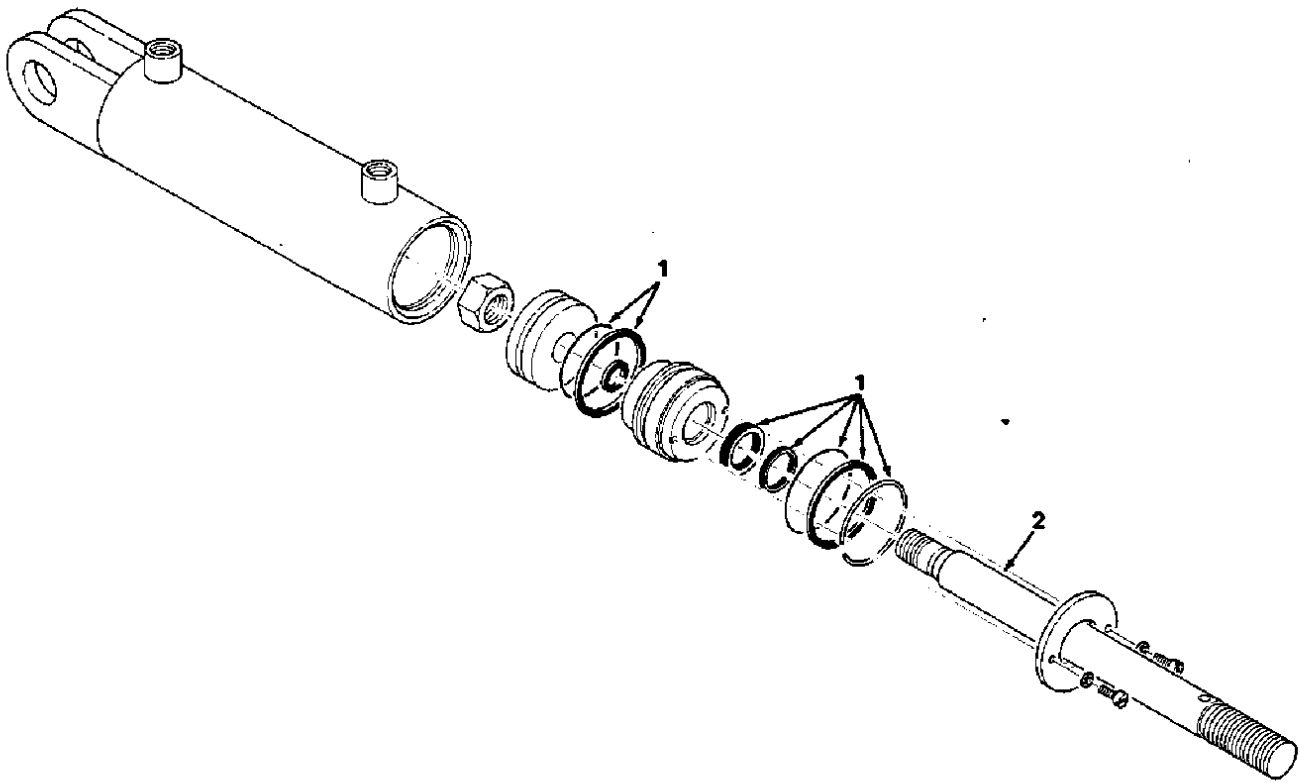

Fig. 16 - Hydraulic Cylinder Breakdown

02607

Key	Tennant® Part No.	Machine Serial Number	Description	Qty.
1	82756 34167	(000000-) (000000-)	Cylinder, Hydraulic Seal Kit	1 1

SECTION 13

ENGINE PARTS, GASOLINE, LPG

CONTENTS

	Page
Ordering Repair Parts	13-1
Fig. 1 - Cylinder Block, Head, and Manifolds Group	13-2
Fig. 2 - Crankshaft Group	13-3
Fig. 3 - Valves and Valve Cover Group	13-4
Fig. 4 - Camshaft Group	13-6
Fig. 5 - Piston and Connecting Rod Group .	13-7
Fig. 6 - Oil Pump, Filter, and PCV Group ..	13-8
Fig. 7 - Water Pump and Thermostat Group	13-10
Fig. 8 - Distributor and Spark Plugs Group .	13-11
Fig. 9 - Gasket Kits Group	13-12

NOTE: Section 13, Engine Parts, Gasoline, LPG, lists the repair parts for the gasoline and LPG powered engines.

ORDERING REPAIR PARTS

The components used in this machine have been carefully selected for performance and safety. Use only Tennant Company specified or equivalent parts.

To receive prompt service in filling of your parts orders, please direct all orders for parts with Tennant Company part numbers to the Tennant Company, and all orders for parts with vendor part numbers to the local supplier of the respective vendor.

When ordering parts, please furnish all of the following information:

1. Machine model number - shown on the machine data plate.

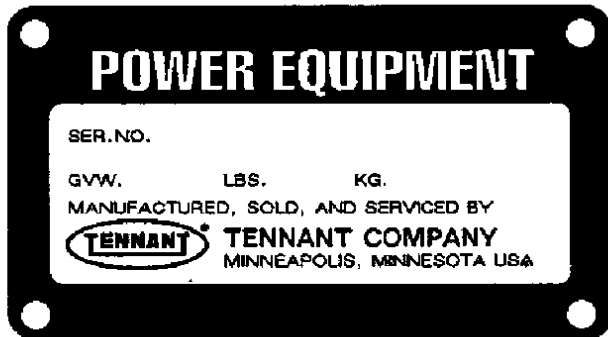

2. Machine serial number - shown on the machine data plate.
3. Engine type - gasoline, LPG, diesel, electric.
4. Company name.
5. Shipping address.
6. Billing address.
7. Name, first and last - of person ordering parts.
8. Telephone number.
9. Purchase order number.
10. Part number, description, and quantity - of each item on the order.

Do not order parts by key number or the figure number of the illustrated parts. Indented items indicate parts of assemblies. Standard hardware is furnished only when part of a purchased assembly. Please get hardware from a local hardware supplier.

If the old part cannot be identified, send it to us with the quantity needed specified on the order.

Any claim for loss or damage to a shipment in transit should be filed promptly against the transportation company making the delivery. Shipments will be complete unless the packing list or order acknowledgement indicate items back ordered.

If parts received are suspected to be incorrect or defective, please write, wire, or phone the Tennant Company representative from whom you ordered the part. They will give authorization for return and/or handle replacement shipments when required.

SERIAL NUMBER INFORMATION EXPLANATION

Serial number listings are shown to indicate on which machines each part can be used. These listings are explained by the following examples:

(000000-) The part can be used on all machines.

(003342-) The part can be used on all machines beginning with the serial number listed.

(000000-004320) The part can be used on all machines up to and including serial number listed.

(004321-005678) The part can be used on all machines between and including the serial numbers listed.

Where xxxxxx's are listed in place of a serial number, it indicates a change was made but the exact serial number had not been established when the catalog went to press.

SI UNITS OF MEASURE (INTERNATIONAL SYSTEM)

Metric equivalents have been included, where applicable, throughout this parts catalog.

FASTENER STRENGTH IDENTIFICATION

Fasteners required to have high-strength qualities equivalent to SAE Grade 8 are identified throughout this catalog by the description GR 8. Unless identified by this description, all standard fasteners are SAE Grade 5.

(Specifications and design subject to change without notice.)

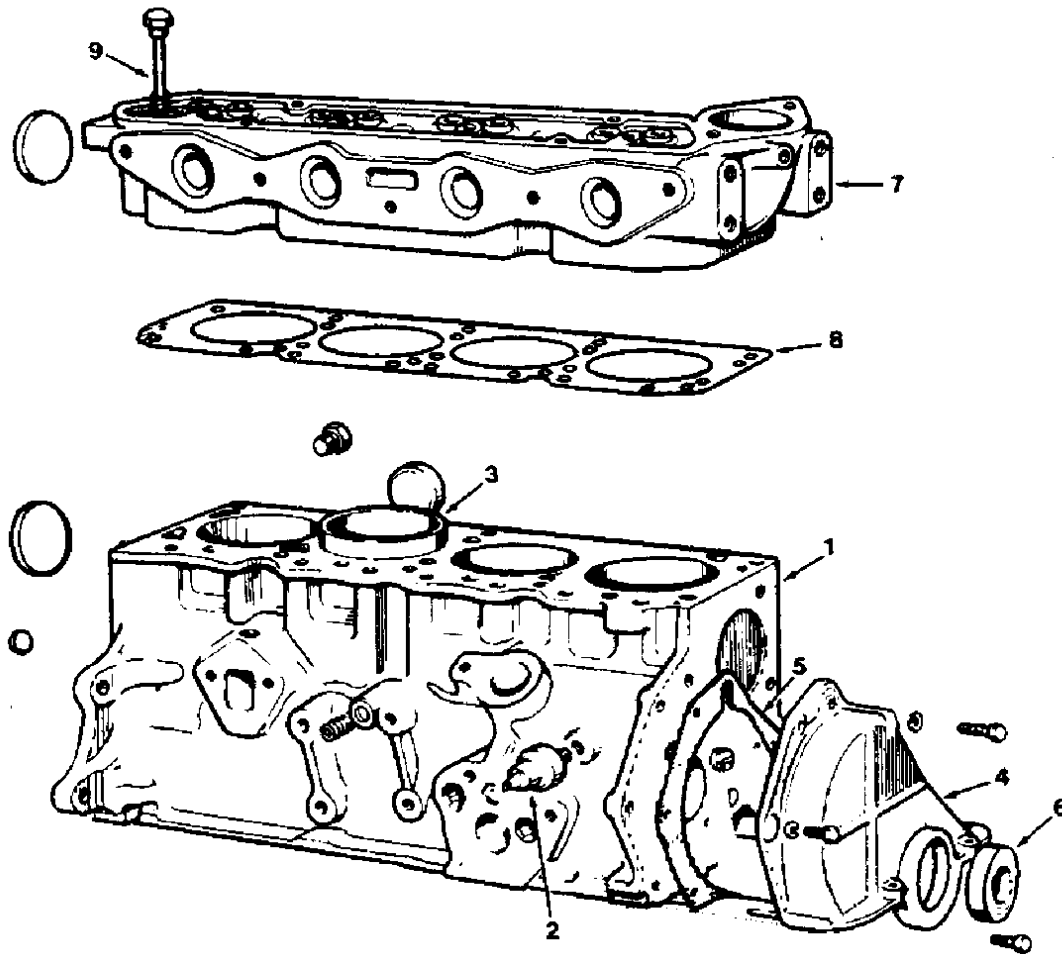

Fig. 1 - Cylinder Block, Head, and Manifolds Group

02311

Key	Tennant® Part No.	Ford Part Number	Engine Serial Number	Description	Qty.
1		711M-6010-BA	(000000-)	Block, Cylinder	1
		761F-6011-CA	(000000-)	Block, Cylinder With Pistons, Etc.	1
2	37351	D9ZZ-9278-A	(000000-)	Switch, Oil Pressure	1
3		DORY-6055-A	(000000-)	Liner, Cylinder Block, Standard	4
3		DORY-6055-B	(000000-)	Liner, Cylinder Block, 0.020" O/s	4
4		731M-8059-BA	(000000-)	Front Cover	1
5	37333	D1FZ-6020-B	(000000-)	Gasket, Front Cover	1
6	37342	D1FZ-6700-B	(000000-)	Seal, Front Cover Oil	1
7		761F-6049-AA	(000000-)	Head, Cylinder	1
8	54911-23	D8RZ-6051-B	(000000-)	Gasket, Cylinder Head	1
9		D1FZ-6065-B	(000000-)	Bolt, Cylinder Head	8
9		D1FZ-6065-C	(000000-)	Bolt, Cylinder Head	2
	38246	761F-9425-AA	(000000-)	Manifold, Intake	1
		113765-ES2	(000000-)	Stud	2
	58049	711F-9430-AC	(000000-)	Manifold, Exhaust	1
	54911-22	DORY-9441-A	(000000-)	Gasket, Intake Manifold	1
	54911-20	DORY-9448-A	(000000-)	Gasket, Exhaust, Inner	1
	54911-21	DORY-9448-B	(000000-)	Gasket, Exhaust, Outer	2

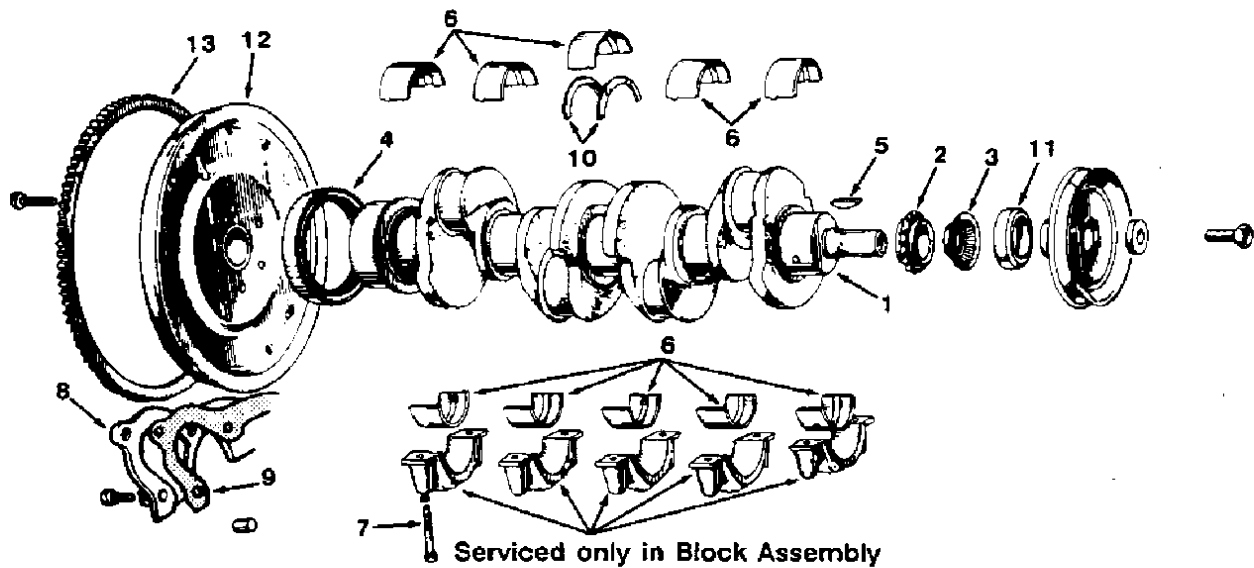

Fig. 2 - Crankshaft Group

02312

Key	Tennant® Part No.	Ford Part Number	Engine Serial Number	Description	Qty.
1		D1FZ-6303-B	(000000-)	Crankshaft	1
2	37321	DORY-6306-A	(000000-)	Sprocket	1
3		D1FZ-6310-A	(000000-)	Slinger	1
4	37343	D1FZ-6701-A	(000000-)	Seal, Crankshaft Rear	1
5	37312	DORY-6B316-A	(000000-)	Key	1
6		D8RZ-6333-A	(000000-)	Bearing, Standard O.D. and Standard I.D.	5
6		D8RZ-6333-D	(000000-)	Bearing, Standard O.D. and 0.010" Undersize I.D.	As Req.
6		D8RZ-6333-T	(000000-)	Bearing, Standard O.D. and 0.020" Undersize I.D.	As Req.
6		D8RZ-6333-F	(000000-)	Bearing, Standard O.D. and 0.030" Undersize I.D.	As Req.
6		D8RZ-6333-AA	(000000-)	Bearing, 0.015" Oversize O.D. and Standard I.D.	As Req.
6		D2FZ-6333-C	(000000-)	Bearing, 0.015" Oversize O.D. and 0.010" Undersize I.D.	As Req.
6		D8RZ-6333-Y	(000000-)	Bearing, 0.015" Oversize O.D. and 0.020" Undersize I.D.	As Req.
6		D8RZ-6333-Z	(000000-)	Bearing, 0.015" Oversize O.D. and 0.030" Undersize I.D.	As Req.
7		D1FZ-6345-B	(000000-)	Bolt, Main Bearing Cap	10
8		D1FZ-6335-C	(000000-)	Retainer	1
9		DORY-6344-A	(000000-)	Gasket	1
10	37689	D1FZ-6A355-A	(000000-)	Washer, Main Bearing, Standard, 2.938" O.D.	2
10	37330	D1FZ-6A355-c	(000000-)	Washer, Main Bearing, 0.005" O.S.	As Req.
10		D1FZ-6A355-D	(000000-)	Washer, Main Bearing, 0.0075" O.S.	As Req.
10		D1FZ-6A355-E	(000000-)	Washer, Main Bearing, 0.010" O.S.	As Req.
12		731M-6375-BA	(000000-)	Flywheel	1
13	37719	D1FZ-6384-A	(000000-)	Gear, Flywheel Ring	1

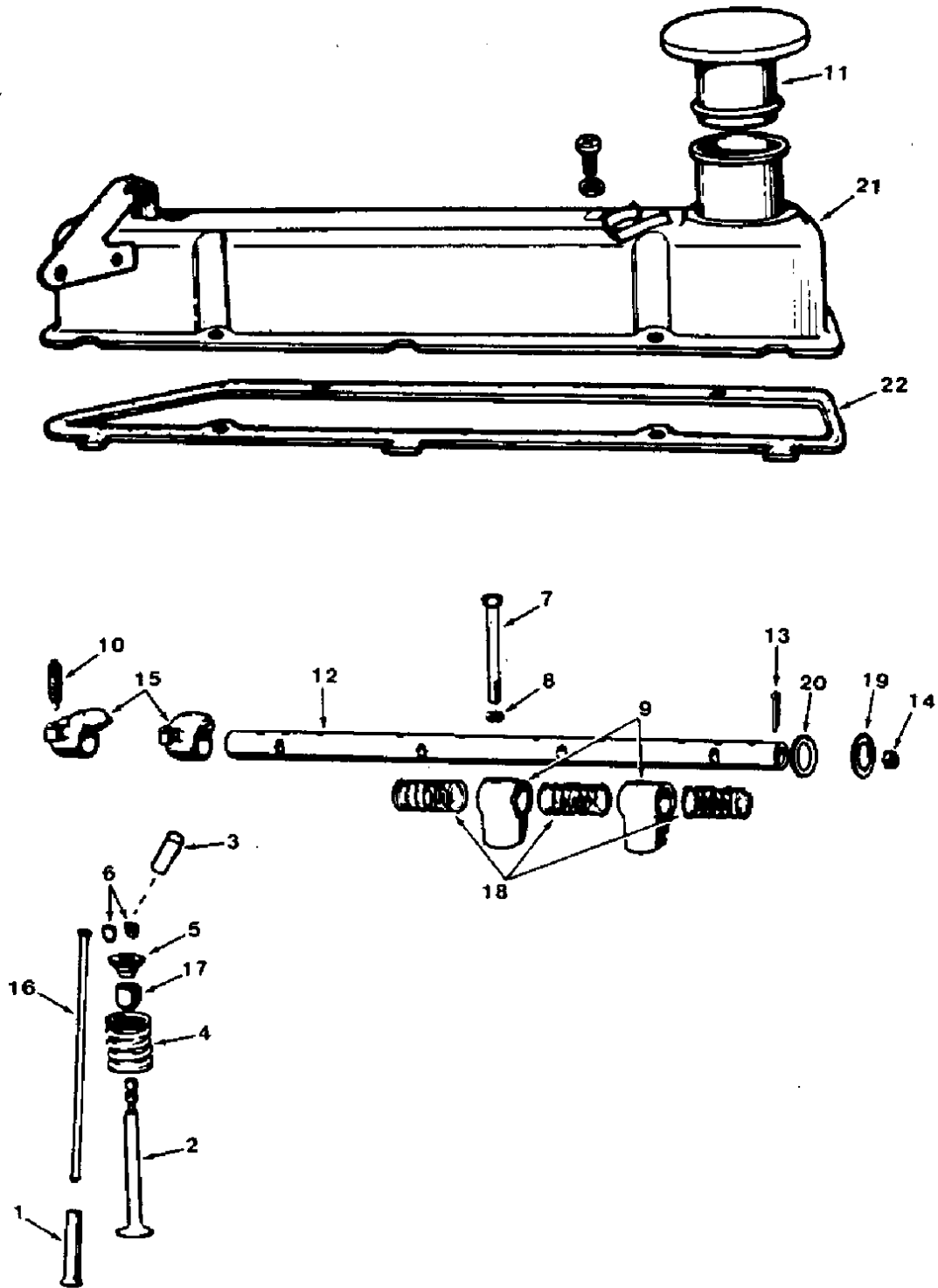

Fig. 3 - Valves and Valve Cover Group

Fig. 3 - Valves and Valve Cover Group

02313

Key	Tennant® Part No.	Ford Part Number	Engine Serial Number	Description	Qty.
1		D1FZ-6500-A	(000000-)	Tappet, Standard 0.515" Stem O.D.	8
		D1FZ-6500-B	(000000-)	Tappet, 0.004" Oversize	As Req.
2		801M-6507-GA	(000000-)	Valve, Standard, 1 Groove, Intake	4
		801M-6507-HA	(000000-)	Valve, 0.015" Oversize, 1 Groove, Intake	As Req.
2	37368	731M-6505-AA	(000000-)	Valve, Standard, 1 Groove, Exhaust	4
2		731M-6505-CA	(000000-)	Valve, 0.015" Oversize, 1 Groove, Exhaust	As Req.
3	37308	DORY-6510-A	(000000-)	Bushing, Valve Guide, Intake, 1.825", Plain	As Req.
3		DORY-6510-C	(000000-)	Bushing, Valve Guide, Intake, 1.825", Shouldered	As Req.
3	37309	DORY-6510-B	(000000-)	Bushing, Valve Guide, Exhaust, 2.075", Plain	As Req.
3		DORY-6510-D	(000000-)	Bushing, Valve Guide, Exhaust, 2.075", Shouldered	As Req.
4	37340	D1FZ-6513-D	(000000-)	Spring	8
5		D1FZ-6514-B	(000000-)	Retainer	8
6		2724E-6518-A	(000000-)	Key	16
7		DORY-6A527-A	(000000-)	Bolt	4
8		DORY-6A528-A	(000000-)	Washer	4
9		DORY-6531-A	(000000-)	Support	4
10	37693	DORY-6549-B	(000000-)	Screw	8
11	50352	D1FZ-6766-B	(000000-)	Cap	1
12		DORY-6563-B	(000000-)	Shaft	1
13		72034-S	(000000-)	Pin, Cotter, 1" Long	2
14		DORY-6026-D	(000000-)	Plug	2
15		DORY-6564-D	(000000-)	Arm, R.H.	4
15		DORY-6564-C	(000000-)	Arm, L.H.	4
16		DORY-6565-A	(000000-)	Rod, Push	8
17	38250	E2JL-6571-AA	(000000-)	Seal	8
18		DORY-6587-A	(000000-)	Spring, Valve Rocker To Shaft	3
19		DORY-6590-A	(000000-)	Washer, Flat Type	4
20		DORY-6598-A	(000000-)	Washer, Spring Type	2
21	37358	701M6582-GA	(000000-)	Cover	1
22	54911-24	D1FZ-6584-C	(000000-)	Gasket	1

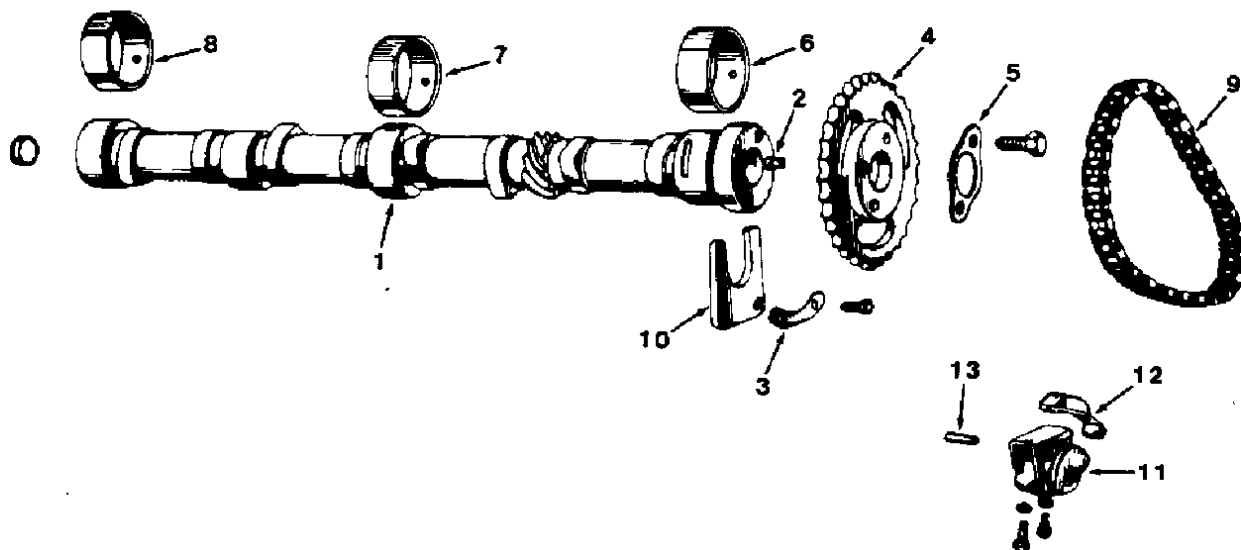

Fig. 4 - Camshaft Group

00746

Key	Tennant® Part No.	Ford Part Number	Engine Serial Number	Description	Qty.
1		711F-6250-DA	(000000-)	Camshaft	1
2		DORY-6253-A	(000000-)	Dowel	1
3		DORY-6255-A	(000000-)	Retainer	1
4	37315	DORY-6256-A	(000000-)	Sprocket	1
5		DORY-6258-A	(000000-)	Retainer	1
6	37316	DORY-6261-A	(000000-)	Bearing, Front, Standard I.D. and O.D.	1
6	37317	DORY-6261-B	(000000-)	Bearing, Front, Standard I.D. and 0.020" O.S. - O.D.	As Req.
7	37306	DORY-6262-A	(000000-)	Bearing, Center, Standard I.D. and O.D.	1
7	38242	DORY-6262-B	(000000-)	Bearing, Center, Standard I.D. and 0.020" O.S. - O.D.	As Req.
8		DORY-6263-A	(000000-)	Bearing, Rear, Standard I.D. and O.D.	1
8		DORY-6263-B	(000000-)	Bearing, Rear, Standard I.D. and 0.020" O.S. - O.D.	As Req.
9	37307	DORY-6268-A	(000000-)	Chain	1
10		DORY-6269-A	(000000-)	Plate	1
11	37337	D1FZ-6284-A	(000000-)	Tensioner	1
12	37338	D1FZ-6285-A	(000000-)	Arm	1
13	37694	D1FZ-6286-A	(000000-)	Pin	1

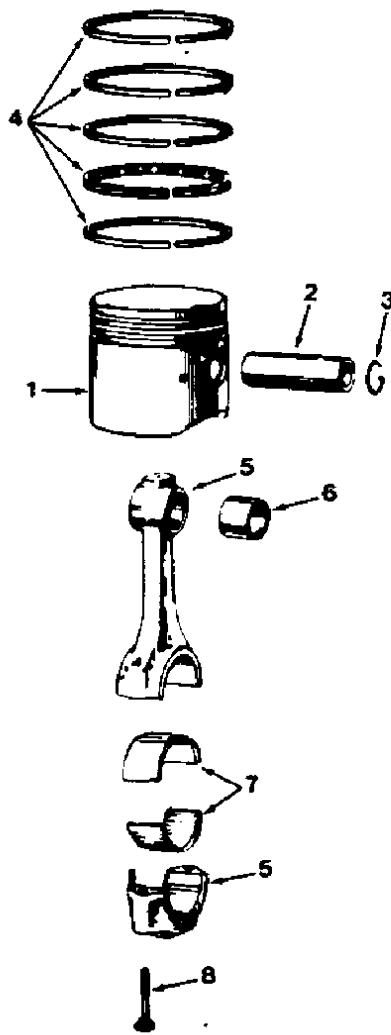

Fig. 5 - Piston and Connecting Rod Group

00742

Key	Tennant® Part No.	Ford Part Number	Engine Serial Number	Description	Qty.
1		751M-6102-ARB	(000000-)	Piston, Standard	4
1		751M-6102-AUB	(000000-)	Piston, 0.030" O/s	As Req.
2		DORY-6135-A	(000000-)	Pin, Standard	4
2		DORY-6135-C	(000000-)	Pin, 0.002" Undersize	As Req.
3		DORY-6140-A	(000000-)	Retainer, Pin	8
4		751M-6149-AA	(000000-)	Ring Set, Piston, Standard	1
4		751M-6149-DA	(000000-)	Ring, Piston, 0.030" O/s	As Req.
5		DORY-6200-A	(000000-)	Rod Assembly	4
6		105e-6207-B	(000000-)	Bushing	4
7	38243	D1FZ-6211-AA	(000000-)	Bearing, Standard	8
7		D1FZ-6211-AB	(000000-)	Bearing, 0.001" Undersize	As Req.
7		D1FZ-6211-AC	(000000-)	Bearing, 0.002" Undersize	As Req.
7	37335	D1FZ-6211-AD	(000000-)	Bearing, 0.010" Undersize	As Req.
7		D1FZ-6211-AE	(000000-)	Bearing, 0.020" Undersize	As Req.
7		D1FZ-6211-AF	(000000-)	Bearing, 0.030" Undersize	As Req.
7		D1FZ-6211-AG	(000000-)	Bearing, 0.040" Undersize	As Req.
8		DORY-6214-A	(000000-)	Bolt, 0.38" - 24 X 1.718"	8

Fig. 6 - Oil Pump, Filter, and PCV Group

02914

Key	Tennant® Part No.	Ford Part Number	Engine Serial Number	Description	Qty.
1	37844	731M-6600-AA	(000000-	Oil Pump	1
2		D1FZ-6608-B	(000000-	Rotor and Shaft	1
3	37403	116682-ES	(000000-	O-Ring	1
4		DORY-6622-A	(000000-	Tube, Oil Pickup	1
5		DORY-6652-A	(000000-	Gear	1
6		72432-S	(000000-	Pin	1
7		DORY-6K656-A	(000000-	Tube, Oil Return	1
8	37341	D1FZ-6659-A	(000000-	Gasket	1
9		DORY-6A665-A	(000000-	Adaptor, Crankcase Ventilation	1
10	38245	73HF-6A666-AB	(000000-	Valve, Crankcase Ventilation, PCV	1
11		751F-6K609-AB	(000000-	Hose, PCV	1
12		DORY-6670-A	(000000-	Spring	1
13		DORY-6674-A	(000000-	Plunger	1
14	58122	FL-271	(000000-	Oil Filter	1
15	37326	DORY-6675-C	(000000-	Oil Pan	1
16	37354	D6TZ-6730-A	(000000-	Plug, Oil Drain	1
17	37303	C20Z-6734-A	(000000-	Gasket, Oil Drain	1
18	54911-27	DORY-6754-A	(000000-	Tube, Oil Level Indicator	1
19		DORY-6K777-A	(000000-	O-Ring	1
20	37344	D1FZ-6781-B	(000000-	Gasket, Oil Pan	1
21		D1FZ-6A785-B	(000000-	Separator	1
22		D1FZ-6890-B	(000000-	Insert, Oil Filter Mounting Bolt	1
23		C8SZ-6A892-A	(000000-	Grommet, PCV Valve	1

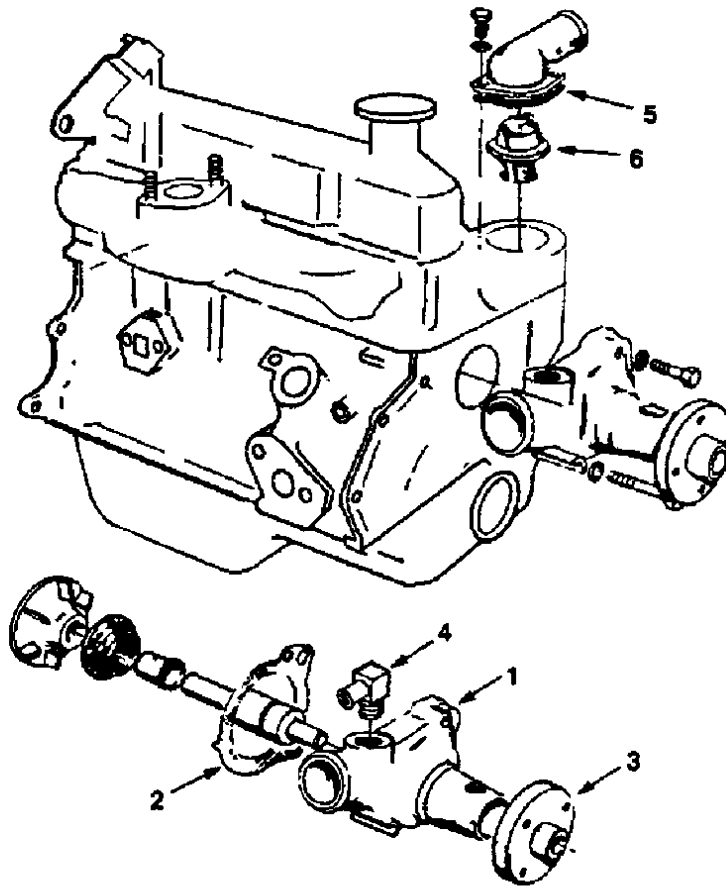

Fig. 7 - Water Pump and Thermostat Group

02315

Key	Tennant® Part No.	Ford Part Number	Engine Serial Number	Description	Qty.
1	33864		(000000-)	Replacement Kit, Water Pump	1
2	37325	DORY-8507-A	(000000-)	Gasket	1
3		DORY-8553-A	(000000-)	Hub	1
4	51839		(000000-)	Fitting, Elbow	1
5	54911-25	D1FZ-8255B	(000000-)	Gasket	1
6	37327	D4PZ-8575-A	(000000-)	Thermostat	1

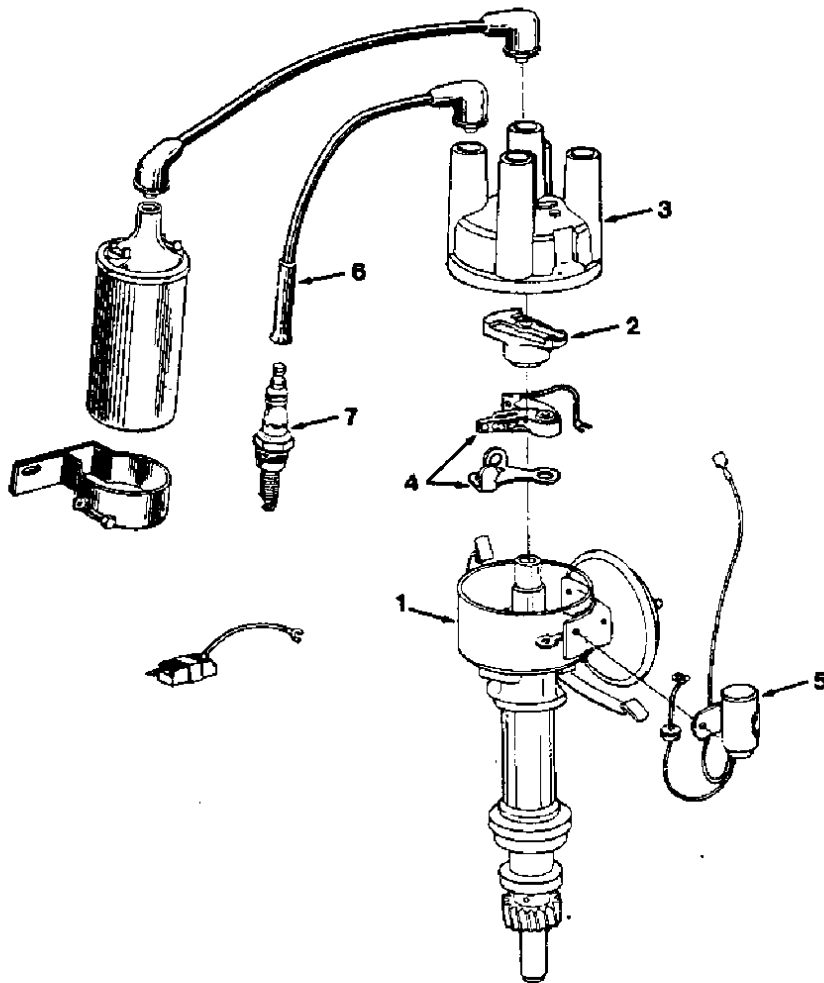

Fig. 8 - Distributor and Spark Plugs Group

02526

Key	Tennant® Part No.	Ford Part Number	Engine Serial Number	Description	Qty.
1	06997		(000000-)	Distributor Kit	1
2	82697		(000000-)	Rotor, Overspeed Protection	1
3	58507	D1FZ-2106-A	(000000-)	Cap	1
4	58506	77BF-12171-AA	(000000-)	Points Set	1
5	58509	831F-12300-AA	(000000-)	Condenser	1
6	37328	D1FZ-12259-A	(000000-)	Wire Kit, Ignition	1
		721F-12283-BA	(000000-)	Wire, No. 2	1
		721F-12284-AA	(000000-)	Wire, No. 3	1
		721F-12286-BA	(000000-)	Wire, No. 1	1
		721F-12287-AA	(000000-)	Wire, No. 4	1
7	45770-8	AGR-22	(000000-)	Spark Plug	4

NOTE: To identify parts shown but not listed here, see Section 5, Low Dump Model Parts.

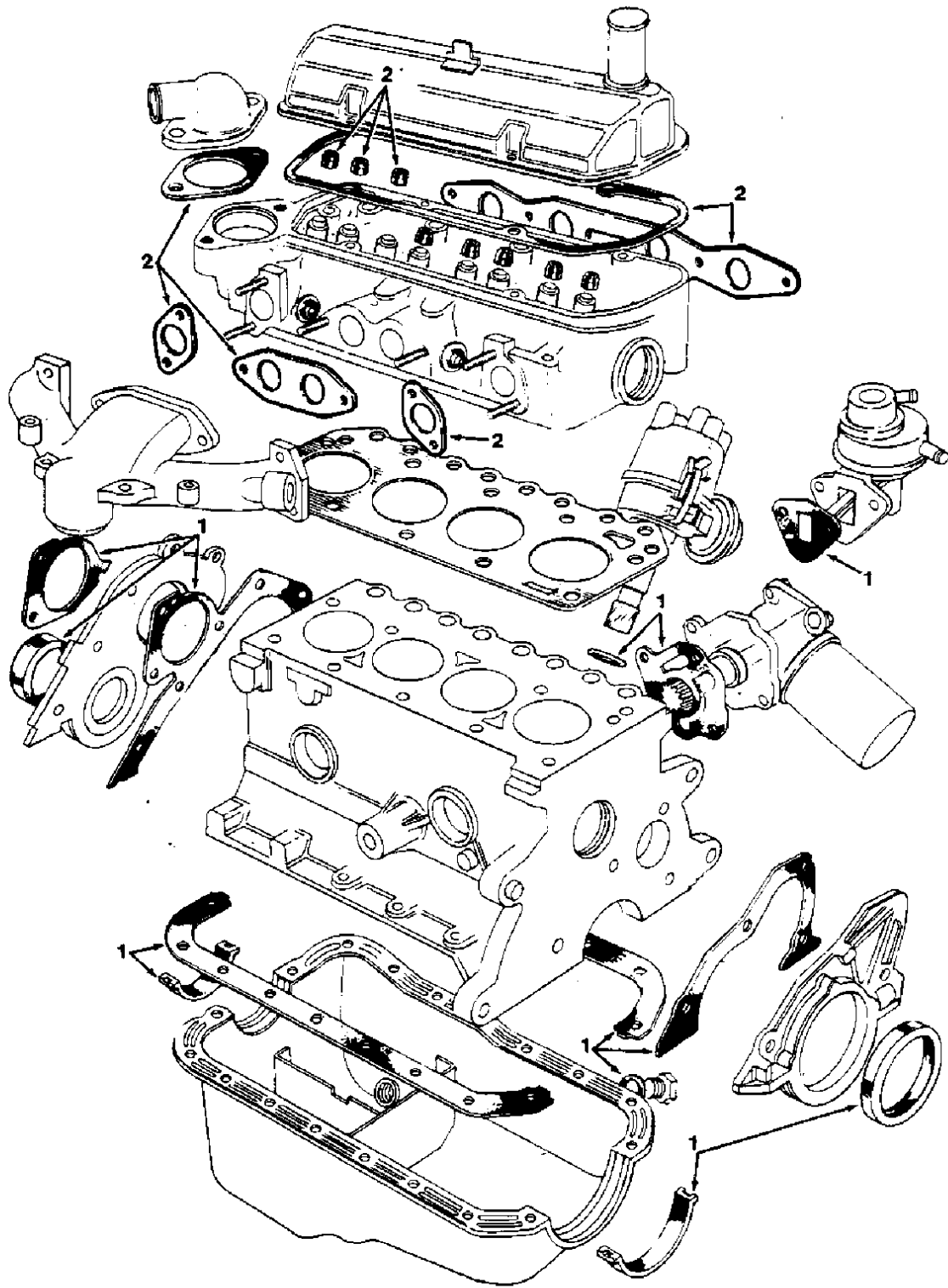

Fig. 9 - Gasket Kits Group

00749

Key	Tennant® Part No.	Ford Part Number	Engine Serial Number	Description	Qty.
1	37332	D1FZ-6008-A	(000000-)	Gasket Kit, Engine Overhaul	1
2	37334	D1FZ-6079-A	(000000-)	Gasket Kit, Valve Grind	1

SECTION 14

ENGINE PARTS, DIESEL

CONTENTS

	Page
Ordering Repair Parts	14-1
Fig. 1 - Crankcase Group	14-2
Fig. 2 - Oil Pan Group	14-4
Fig. 3 - Cylinder Head Group	14-5
Fig. 4 - Gear Case Group	14-7
Fig. 5 - Main Bearing Case Group	14-8
Fig. 6 - Inlet Manifold Group	14-9
Fig. 7 - Valve, Rocker Arm Group	14-10
Fig. 8 - Head Cover Group	14-12
Fig. 9 - Piston and Crankshaft Group	14-14
Fig. 10 - Camshaft Group	14-16
Fig. 11 - Flywheel Group	14-17
Fig. 12 - Nozzle Group	14-18
Fig. 13 - Fuel Camshaft Group	14-20
Fig. 14 - Governor Group	14-22
Fig. 15 - Speed Control Plate Group	14-23
Fig. 16 - Stop Lever Group	14-24
Fig. 17 - Thermostat Group	14-25
Fig. 18 - Water Pump Group	14-26
Fig. 19 - Starter Breakdown	14-27

NOTE: Section 14, Engine Parts, Diesel, lists the repair parts for diesel powered engines.

ORDERING REPAIR PARTS

For Engine Tennant Part No. 82530

The components used in this machine have been carefully selected for performance and safety. Use only Tennant Company specified or equivalent parts.

To receive prompt service in filling of your parts orders, please direct all orders for parts with Tennant Company part numbers to the Tennant Company, and all orders for parts with vendor part numbers to the local supplier of the respective vendor.

When ordering parts, please furnish all of the following information:

1. Machine model number - shown on the machine data plate.

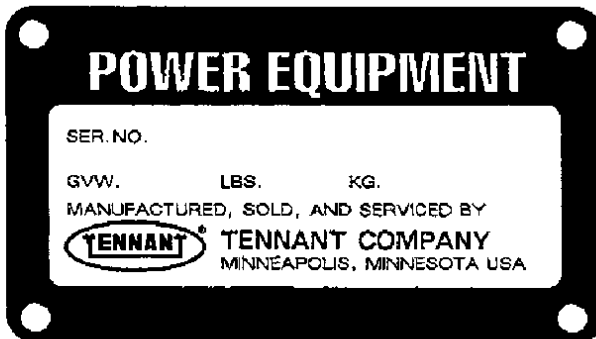

2. Machine serial number - shown on the machine data plate.
3. Engine type - gasoline, LPG, diesel, electric.
4. Company name.
5. Shipping address.
6. Billing address.
7. Name, first and last - of person ordering parts.
8. Telephone number.
9. Purchase order number.
10. Part number, description, and quantity - of each item on the order.

Do not order parts by key number or the figure number of the illustrated parts. Indented items indicate parts of assemblies. Standard hardware is furnished only when part of a purchased assembly. Please get hardware from a local hardware supplier.

If the old part cannot be identified, send it to us with the quantity needed specified on the order.

Any claim for loss or damage to a shipment in transit should be filed promptly against the transportation company making the delivery. Shipments will be complete unless the packing list or order acknowledgement indicate items back ordered.

If parts received are suspected to be incorrect or defective, please write, wire, or phone the Tennant Company representative from whom you ordered the part. They will give authorization for return and/or handle replacement shipments when required.

SERIAL NUMBER INFORMATION EXPLANATION

Serial number listings are shown to indicate on which machines each part can be used. These listings are explained by the following examples:

(000000-) The part can be used on all machines.

(003342-) The part can be used on all machines beginning with the serial number listed.

(000000-004320) The part can be used on all machines up to and including serial number listed.

(004321-005678) The part can be used on all machines between and including the serial numbers listed.

Where xxxxx's are listed in place of a serial number, it indicates a change was made but the exact serial number had not been established when the catalog went to press.

SI UNITS OF MEASURE (INTERNATIONAL SYSTEM)

Metric equivalents have been included, where applicable, throughout this parts catalog.

FASTENER STRENGTH IDENTIFICATION

Fasteners required to have high-strength qualities equivalent to SAE Grade 8 are identified throughout this catalog by the description GR 8. Unless identified by this description, all standard fasteners are SAE Grade 5.

(Specifications and design subject to change without notice.)

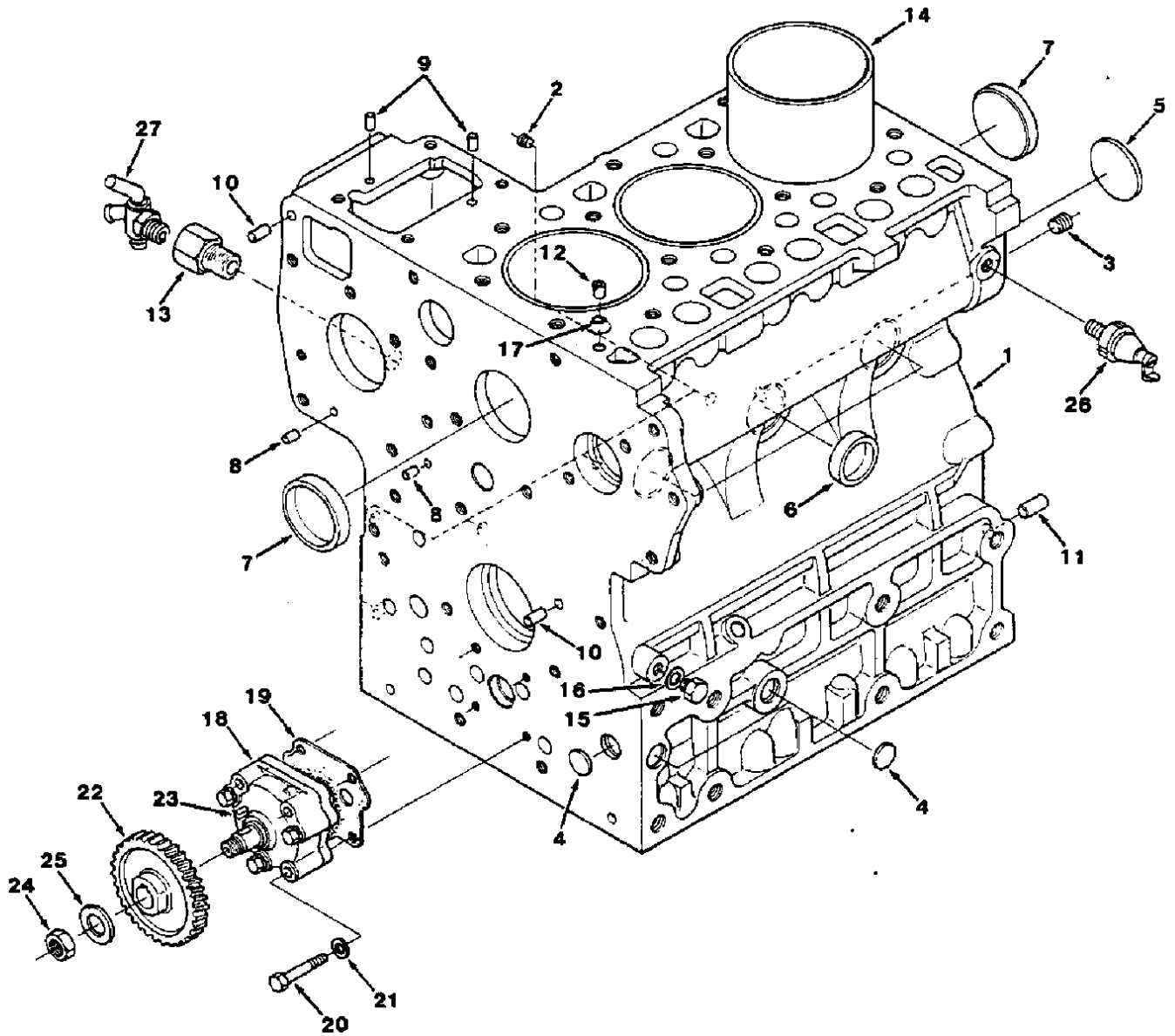

Fig. 1 - Crankcase Group

Fig. 1 - Crankcase Group

02684

Key	Tennant® Part No.	Kubota Part Number	Engine Serial Number	Description	Qty.
1		19271-0101-0	(000000-)	Crankcase Assembly	1
2		15521-9602-0	(000000-)	Plug, Pin	5
3		15521-9603-0	(000000-)	Plug	2
4		06311-75015	(000000-)	Plug, Expansion	3
5		06311-75045	(000000-)	Plug, Expansion	1
6		15221-0338-0	(000000-)	Cap, Sealing	5
7		15221-0339-0	(000000-)	Cap, Sealing	2
8		05012-00408	(000000-)	Pin, Straight	2
9		05012-00609	(000000-)	Pin, Straight	2
10		05012-00612	(000000-)	Pin, Straight	2
11		05012-01018	(000000-)	Pin, Straight	1
12		15221-3365-0	(000000-)	Pin, Pipe	1
13		15291-7316-0	(000000-)	Connector, Drain Cock	1
14		15521-0231-0	(000000-)	Liner, Cylinder	3
15		15221-3361-0	(000000-)	Plug	1
16		15021-3366-0	(000000-)	Gasket	1
17		15221-3370-0	(000000-)	O-Ring	1
18		15321-3501-0	(000000-)	Pump, Oil	1
19		15221-3515-0	(000000-)	Gasket, Oil Pump	1
20		01053-50648	(000000-)	Bolt	4
21		04512-50060	(000000-)	Washer, Spring	4
22		19202-3566-0	(000000-)	Gear, Oil Pump Drive	1
23		05712-00410	(000000-)	Key, Feather	1
24		15221-3568-0	(000000-)	Nut	1
25		15221-3567-0	(000000-)	Washer	1
26		15521-3901-0	(000000-)	Switch, Oil	1
27		14412-7311-0	(000000-)	Cock, Drain	1

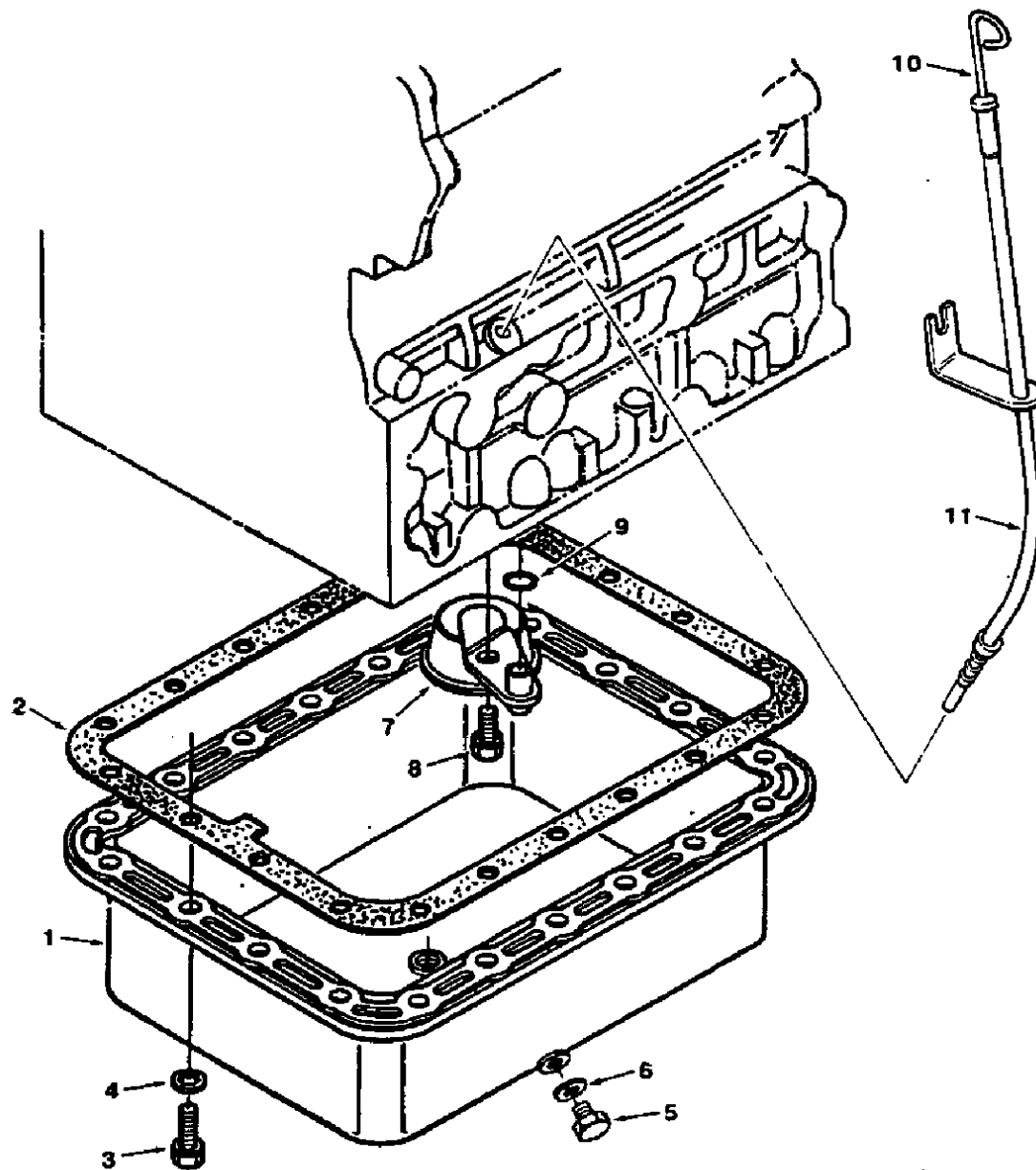

Fig. 2 - Oil Pan Group

02685

Key	Tennant® Part No.	Kubota Part Number	Engine Serial Number	Description	Qty.
1		15324-0161-3	(000000-)	Oil Pan	1
2		15341-0162-0	(000000-)	Gasket, Oil Pan	1
3		01133-51025	(000000-)	Bolt	20
4		15201-9401-0	(000000-)	Washer, Plain	20
5		15221-3375-0	(000000-)	Plug	3
6		15109-3366-0	(000000-)	Gasket	3
7		15401-3211-0	(000000-)	Filter, Oil	1
8		01123-50814	(000000-)	Bolt	1
9		04811-00140	(000000-)	O-Ring	1
10	82539		(000000-)	Gauge, Oil	1
11	82538		(000000-)	Guide, Oil Gauge	1

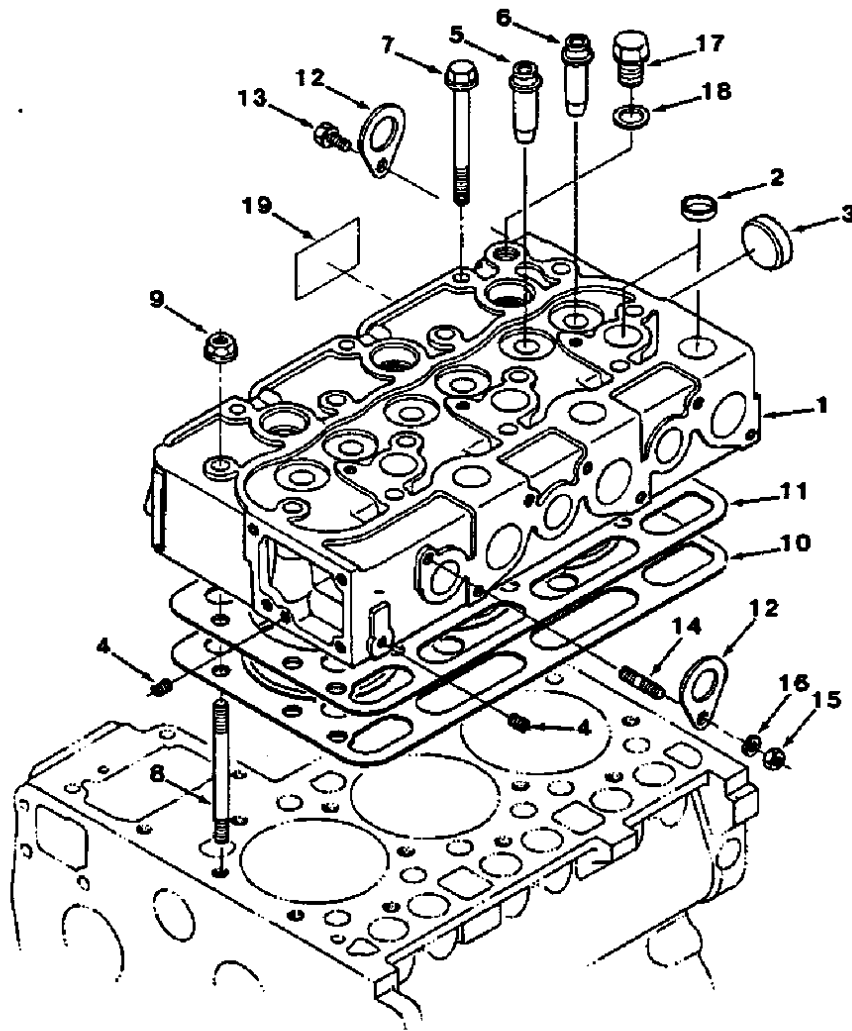

Fig. 3 - Cylinder Head Group

02686

Key	Tennant® Part No.	Kubota Part Number	Engine Serial Number	Description	Qty.
1		15521-0304-0	(000000-	Head Assembly Cylinder	1
2		15221-0337-0	(000000-	Cap, Sealing	9
3		15221-0349-0	(000000-	Cap, Sealing	1
4		15261-9601-0	(000000-	Plug, Pin	2
5		15221-1358-0	(000000-	Guide, Valve	3
6		15601-1356-0	(000000-	Guide, Exhaust Valve	3
7		19202-0345-0	(000000-	Bolt, Head	12
8		19202-0341-0	(000000-	Stud, Head	2
9		19202-0351-0	(000000-	Nut, Head	2
10		15521-0331-0	(000000-	Gasket, Head	1
11		15521-0332-0	(000000-	Shim, Head Gasket	As Req.
12		15221-0175-0	(000000-	Hook, Engine	2
13		01123-50816	(000000-	Bolt	1
14		15521-9149-0	(000000-	Stud	1
15		02156-50080	(000000-	Nut	1
16		04512-50080	(000000-	Washer, Spring	1
17		15000-3608-0	(000000-	Plug, Head	1
18		04717-01600	(000000-	Washer, Seal	1
19		15222-8821-0	(000000-	Label, Caution	1

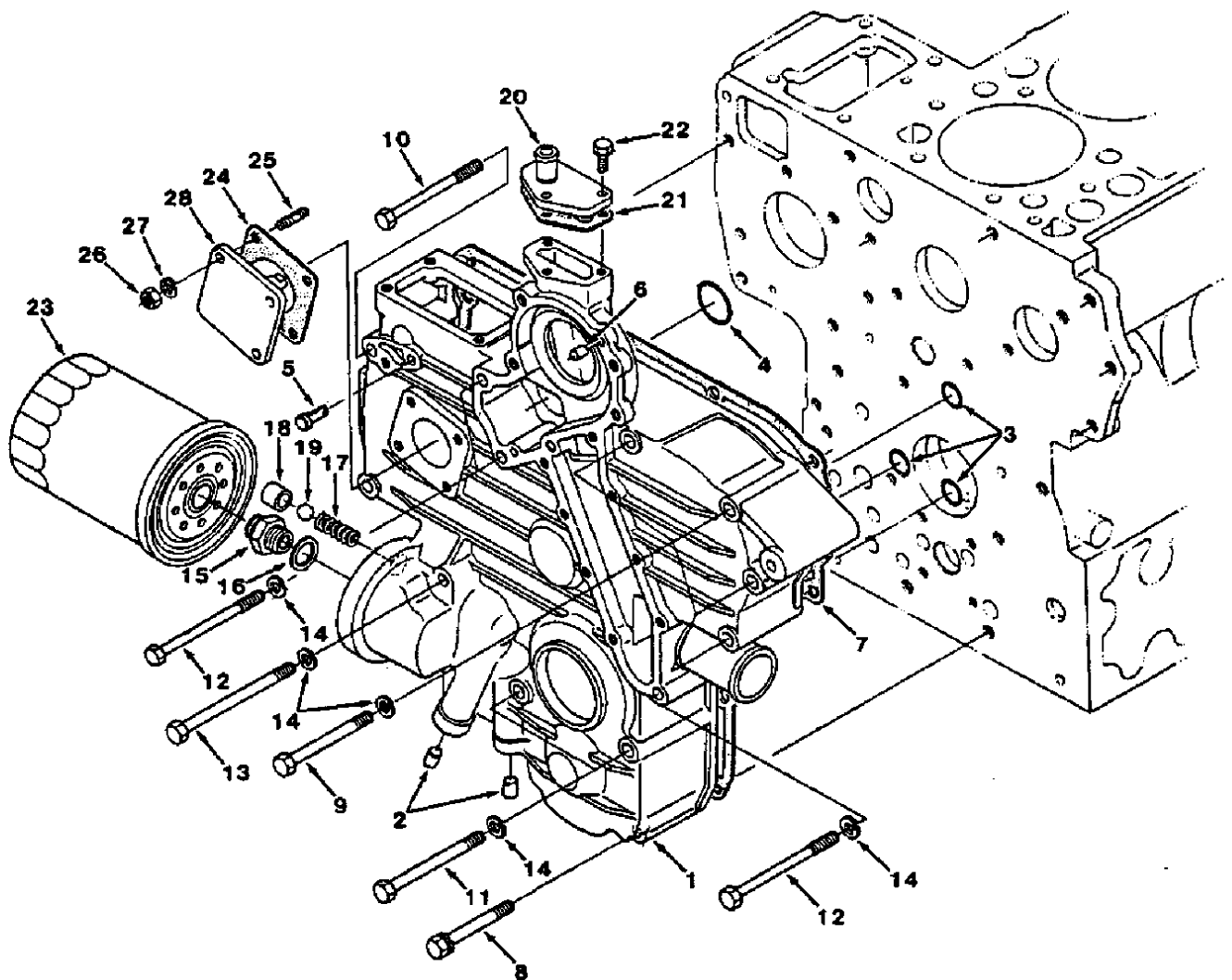

Fig. 4 - Gear Case Group

Fig. 4 - Gear Case Group

02687

Key	Tennant® Part No.	Kubota Part Number	Engine Serial Number	Description	Qty.
1		15521-0402-0	(000000-)	Case Assembly, Gear	1
2		15521-3363-0	(000000-)	Plug, Pin	2
3		04811-00150	(000000-)	O-Ring	3
4		04811-00360	(000000-)	O-Ring	1
5		15221-5628-0	(000000-)	Pin, Start Spring	1
6		05012-00612	(000000-)	Pin, Straight	2
7		15521-0413-0	(000000-)	Gasket, Gear Case	1
8		01123-50860	(000000-)	Bolt	2
9		01153-50870	(000000-)	Bolt	5
10		15521-9101-0	(000000-)	Bolt	1
11		01153-50880	(000000-)	Bolt	2
12		15521-9102-0	(000000-)	Bolt	3
13		01153-50895	(000000-)	Bolt	2
14		04512-50080	(000000-)	Washer, Spring	13
15		15521-3229-0	(000000-)	Joint, Pipe	1
16		04011-50180	(000000-)	Washer, Plain	1
17		15241-3695-0	(000000-)	Spring	1
18		15521-3693-0	(000000-)	Seat, Valve	1
19		07715-03213	(000000-)	Ball	1
20		15521-7332-0	(000000-)	Flange, Water Return	1
21		15521-7333-0	(000000-)	Gasket, Water Return Flange	1
22		01023-50620	(000000-)	Bolt	3
23	82693	15521-3243-0	(000000-)	Cartridge, Oil Filter	1
24		15221-8813-0	(000000-)	Gasket, Hour Meter	1
25		15221-8821-0	(000000-)	Stud	4
26		02056-50060	(000000-)	Nut	4
27		04512-50060	(000000-)	Washer, Spring	4
28		15223-8334-0	(000000-)	Cover	1

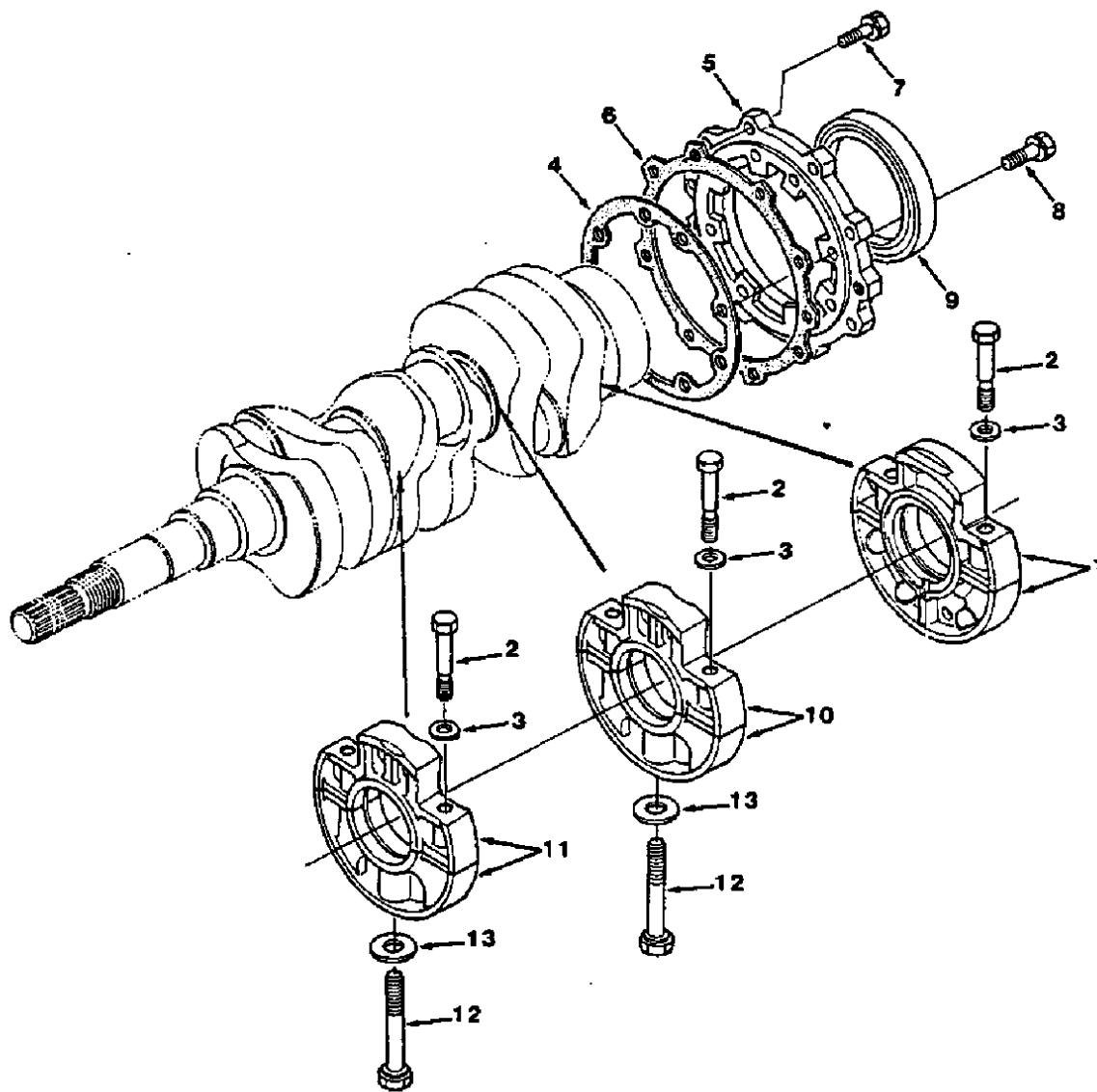

Fig. 5 - Main Bearing Case Group

02688

Key	Tennant® Part No.	Kubota Part Number	Engine Serial Number	Description	Qty.
1		19202-0404-0	(000000-)	Case Assembly, Main Bearing	1
2		15521-0454-0	(000000-)	Bolt, Bearing Case	6
3		15521-9401-0	(000000-)	Washer, Plain	6
4		15221-0436-0	(000000-)	Gasket	1
5		19202-0481-0	(000000-)	Cover, Bearing Case	1
6		15221-0482-0	(000000-)	Gasket	1
7		01123-50825	(000000-)	Bolt	8
8		01123-50828	(000000-)	Bolt	8
9		19202-0446-0	(000000-)	Seal, Oil	1
		09550-00001	(000000-)	Seal, Oil	1
10		15521-0405-0	(000000-)	Case Assembly, Main Bearing	1
11		15521-0406-0	(000000-)	Case Assembly, Main Bearing	1
12		15291-0456-0	(000000-)	Bolt	2
13		15521-9402-0	(000000-)	Washer, Plain	2

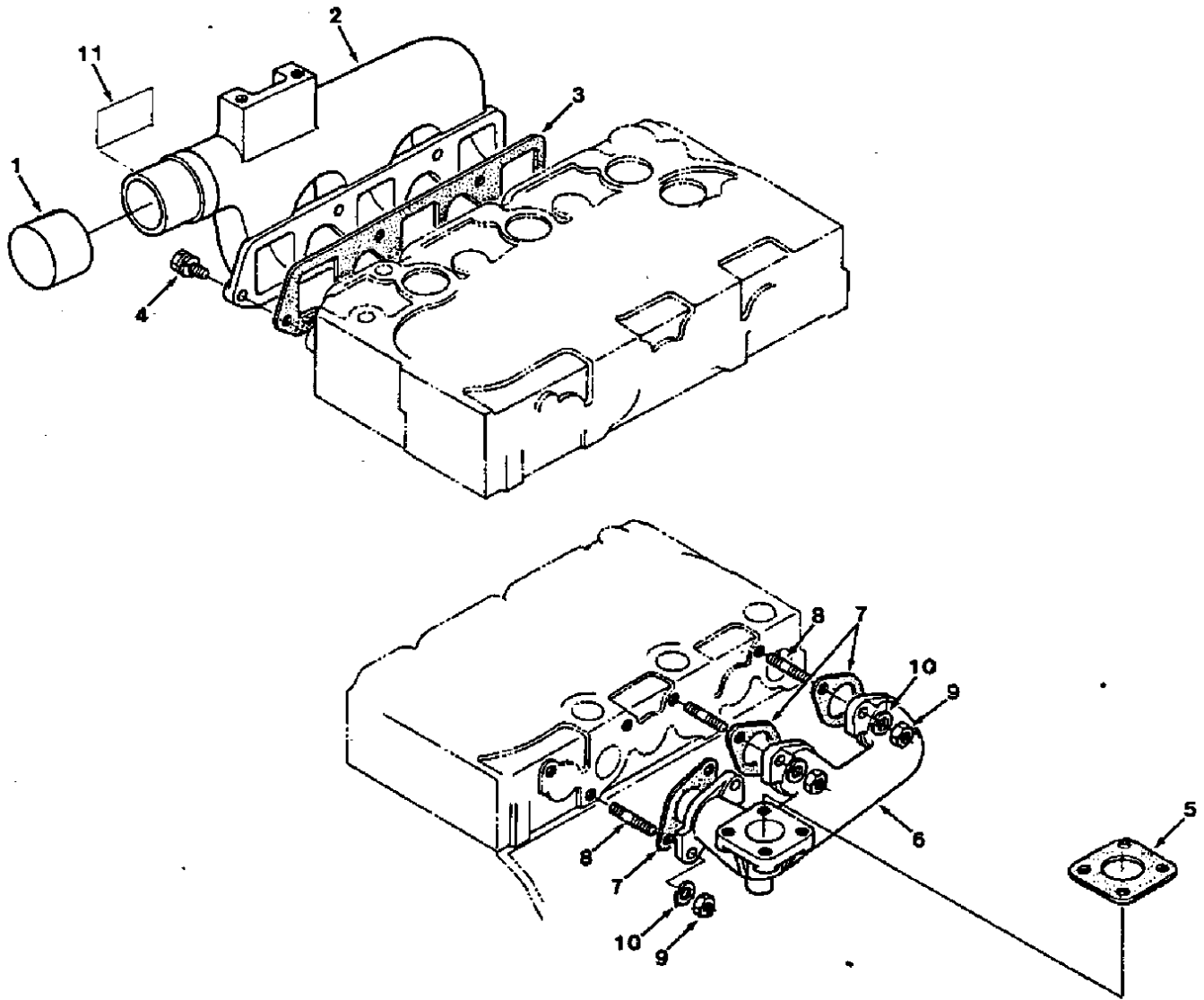

Fig. 6 - Inlet Manifold Group

02689

Key	Tennant® Part No.	Kubota Part Number	Engine Serial Number	Description	Qty.
1		15000-3624-0	(000000-	Cap	1
2		15501-1176-0	(000000-	Manifold, Inlet	1
3		15521-1182-0	(000000-	Gasket, Inlet Manifold	1
4		01123-50822	(000000-	Bolt	5
5		15371-1237-0	(000000-	Gasket, Muffler	1
6		15521-1231-0	(000000-	Manifold, Exhaust	1
7		15521-1235-0	(000000-	Gasket, Exhaust Manifold	3
8		15221-9153-0	(000000-	Stud	6
9		02156-50080	(000000-	Nut	6
10		04512-50080	(000000-	Washer, Spring	6
11		32210-3479-0	(000000-	Label, Decompression	1

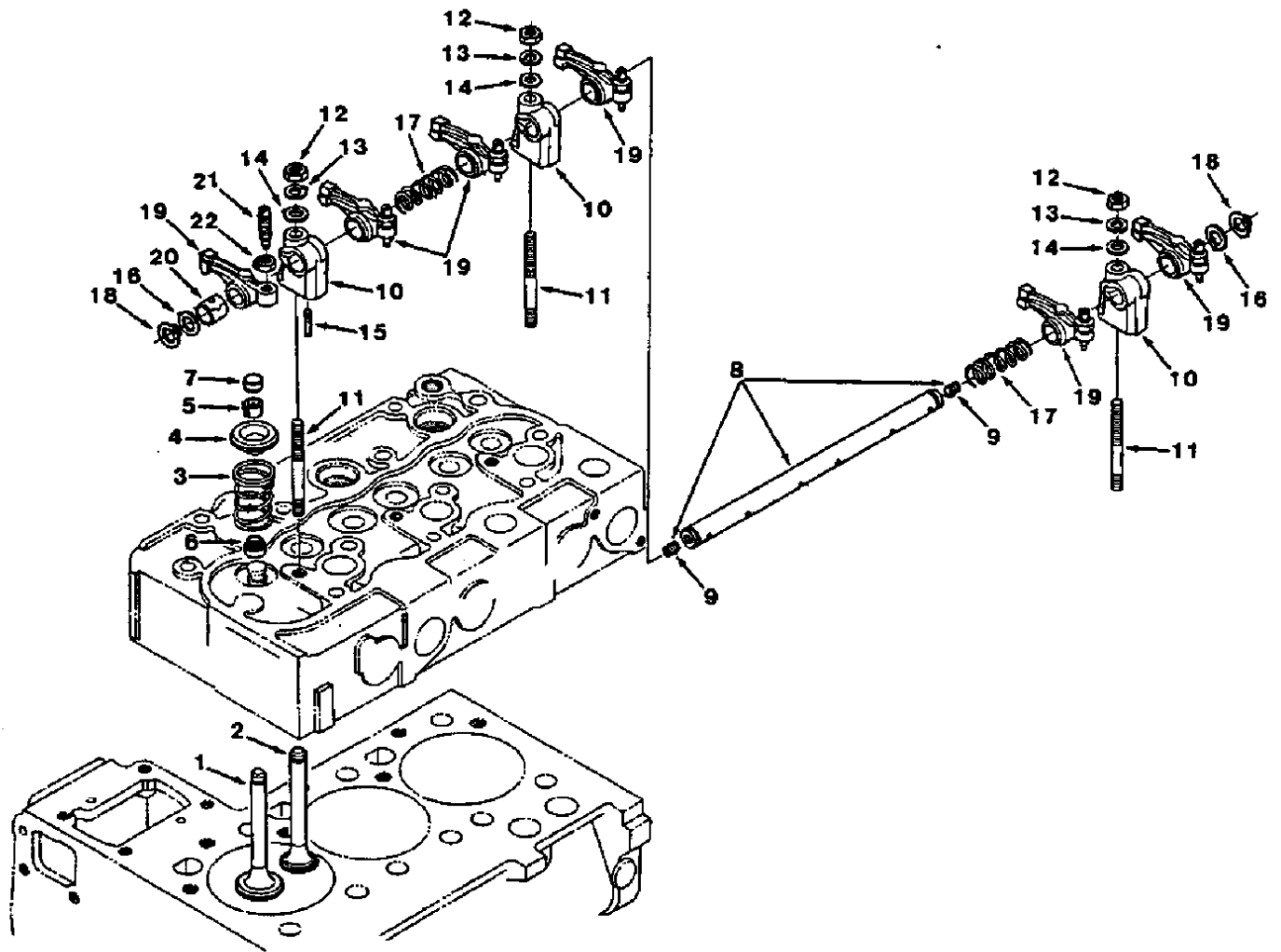

Fig. 7 - Valve, Rocker Arm Group

Fig. 7 - Valve, Rocker Arm Group

02690

Key	Tennant® Part No.	Kubota Part Number	Engine Serial Number	Description	Qty.
1		15221-1311-0	(000000-)	Valve, Inlet	3
2		15221-1312-0	(000000-)	Valve, Exhaust	3
3		15221-1324-0	(000000-)	Spring, Valve	6
4		15221-1333-0	(000000-)	Retainer, Valve Spring	6
5		15221-1336-0	(000000-)	Collet, Valve Spring	12
6		15221-1315-0	(000000-)	Seal, Valve Stem	6
7		15221-1328-0	(000000-)	Cap, Valve	6
8		15321-1405-0	(000000-)	Shaft Assembly, Rocker Arm	1
9		03410-00808	(000000-)	Screw, Set	2
10		15221-1435-0	(000000-)	Bracket, Rocker Arm	3
11		15521-9150-0	(000000-)	Stud	3
12		02156-50080	(000000-)	Nut	3
13		04512-50080	(000000-)	Washer, Spring	3
14		04012-50080	(000000-)	Washer, Plain	3
15		15221-1442-0	(000000-)	Screw, Set	1
16		15221-1443-0	(000000-)	Washer	2
17		15221-1431-0	(000000-)	Spring, Rocker Arm	2
18		04612-00140	(000000-)	Cir-Clip, External	2
19		15601-1403-0	(000000-)	Arm Assembly, Rocker	6
20		15221-1418-0	(000000-)	Bushing, Rocker Arm	6
21		15521-1423-0	(000000-)	Screw, Adjusting	6
22		15021-1424-0	(000000-)	Nut	6

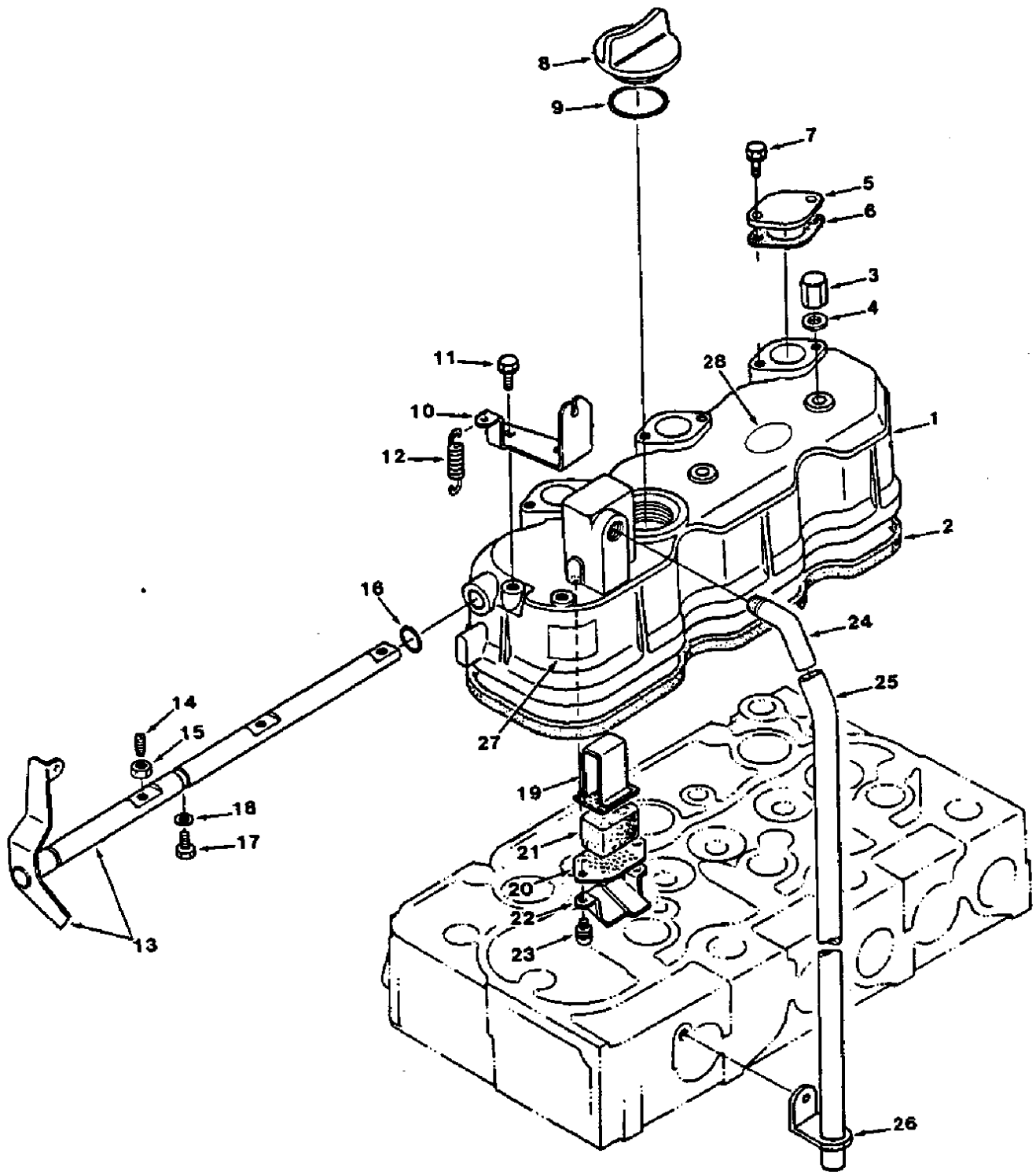

Fig. 8 - Head Cover Group

Fig. 8 - Head Cover Group

02691

Key	Tennant® Part No.	Kubota Part Number	Engine Serial Number	Description	Qty.
1		15521-1451-0	(000000-)	Cover, Cylinder Head	1
2		15521-1452-0	(000000-)	Gasket, Head Cover	1
3		15451-9233-0	(000000-)	Nut, Cap	3
4		15021-3366-0	(000000-)	Gasket	3
5		15221-6663-0	(000000-)	Cover, Decompression Hole	3
6		15221-6664-0	(000000-)	Gasket, Cover	3
7		01023-50614	(000000-)	Bolt	6
8		15221-3314-0	(000000-)	Plug, Oil Filler	1
9		04811-50300	(000000-)	O-Ring	1
10		15221-6619-0	(000000-)	Holder, Decompression Wire	1
11		01023-50614	(000000-)	Bolt	2
12		15221-6628-0	(000000-)	Spring, Decompression	1
13		15521-6604-0	(000000-)	Shaft Assembly, Decompression	1
14		15221-6635-0	(000000-)	Bolt, Decompression	3
15		15221-6636-0	(000000-)	Nut, Decompression	3
16		04811-06100	(000000-)	O-Ring	1
17		15221-6641-0	(000000-)	Bolt	1
18		04512-50060	(000000-)	Washer, Spring	1
19		15521-0514-0	(000000-)	Plate, Breather Element	1
20		15521-0515-0	(000000-)	Plate, Breather Element	1
21		15521-0567-0	(000000-)	Element, Breather	1
22		15521-0537-0	(000000-)	Oil Shield, Breather	1
23		15521-9331-0	(000000-)	Screw	2
24		15521-0555-0	(000000-)	Joint, Breather Pipe	1
25		15521-0551-0	(000000-)	Pipe, Breather	1
26		15401-0558-0	(000000-)	Clamp, Pipe	1
27		19271-8711-0	(000000-)	Plate, Name	1
28		19231-8731-0	(000000-)	Label, Oil	1

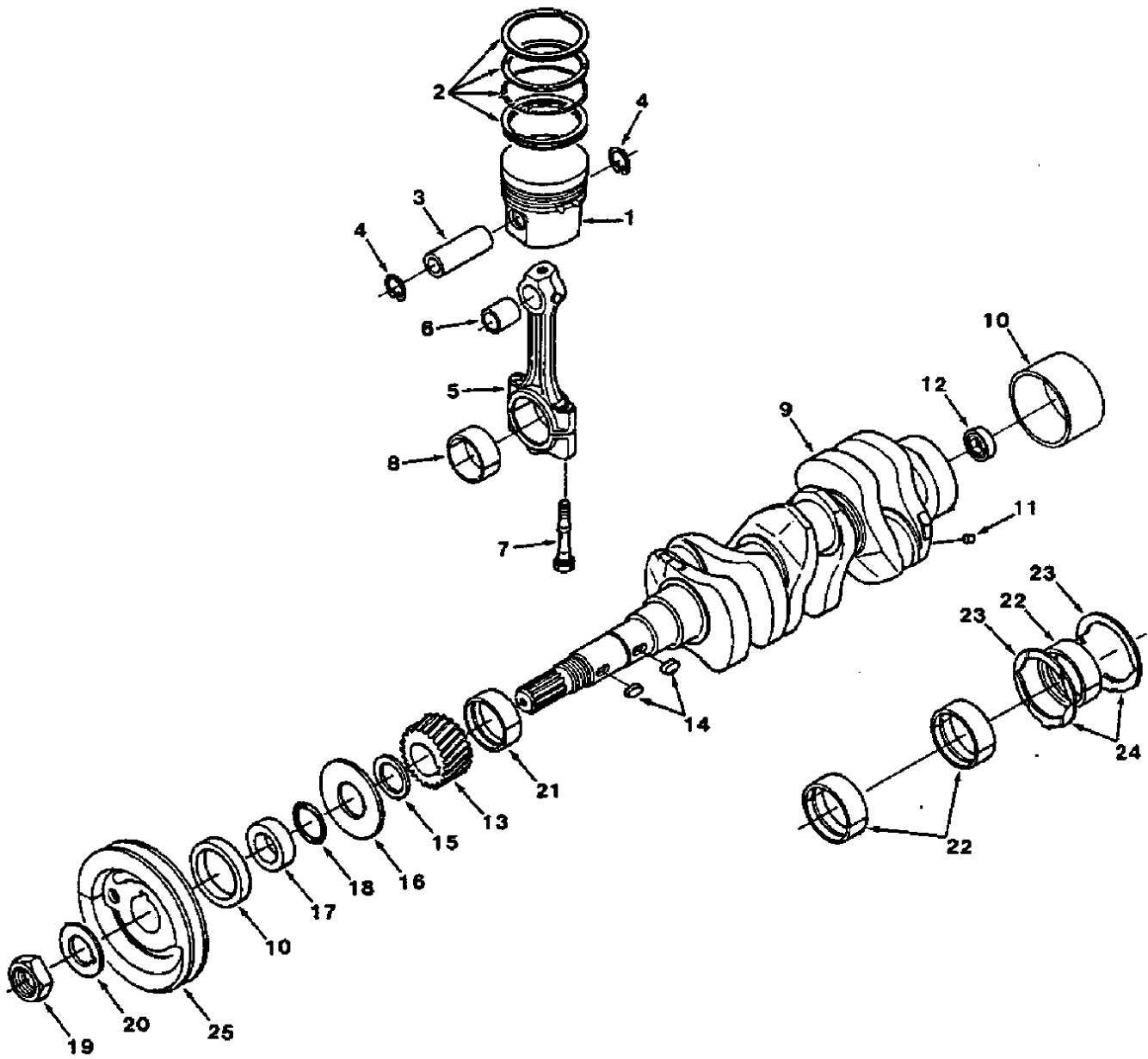

Fig. 9 - Piston and Crankshaft Group

Fig. 9 - Piston and Crankshaft Group

02693

Key	Tennant® Part No.	Kubota Part Number	Engine Serial Number	Description .	Qty.
1		15521-2111-0	(000000-)	Piston	3
2		15521-2105-0	(000000-)	Ring Assembly, Piston	3
3		15521-2131-0	(000000-)	Pin, Piston	3
4		15221-2133-0	(000000-)	Cir-Clip, Piston Pin	6
5		15471-2201-0	(000000-)	Rod Assembly, Connecting	3
6		15221-2198-0	(000000-)	Bushing, Piston Pin	3
7		15521-2214-0	(000000-)	Bolt, Connecting Rod	6
8		15471-2231-0	(000000-)	Bearing, Crank Pin	6
9		15595-2301-0	(000000-)	Crankshaft Assembly	1
10		19202-2328-0	(000000-)	Sleeve, Crankshaft	1
11		15221-3363-0	(000000-)	Plug, Pin	3
12		08121-06002	(000000-)	Bearing, Ball	1
13		15521-2411-0	(000000-)	Gear, Crankshaft	1
14		05712-00720	(000000-)	Key, Feather	2
15		15221-2413-0	(000000-)	Collar, Crank Gear	1
16		15221-2331-0	(000000-)	Slinger, Oil	1
17		19202-2325-0	(000000-)	Collar, Crankshaft	1
18		04811-10300	(000000-)	O-Ring	1
19		15221-2336-0	(000000-)	Nut, Crankshaft	1
20		15221-2338-0	(000000-)	Washer, Crankshaft	1
21		15221-2347-0	(000000-)	Bearing, Crankshaft	1
22		15221-2348-0	(000000-)	Bearing, Crankshaft	6
23		15521-2353-0	(000000-)	Bearing, Side	2
24		19202-2354-0	(000000-)	Bearing, Side	2
25		15321-7428-0	(000000-)	Sheave, Crankshaft	1

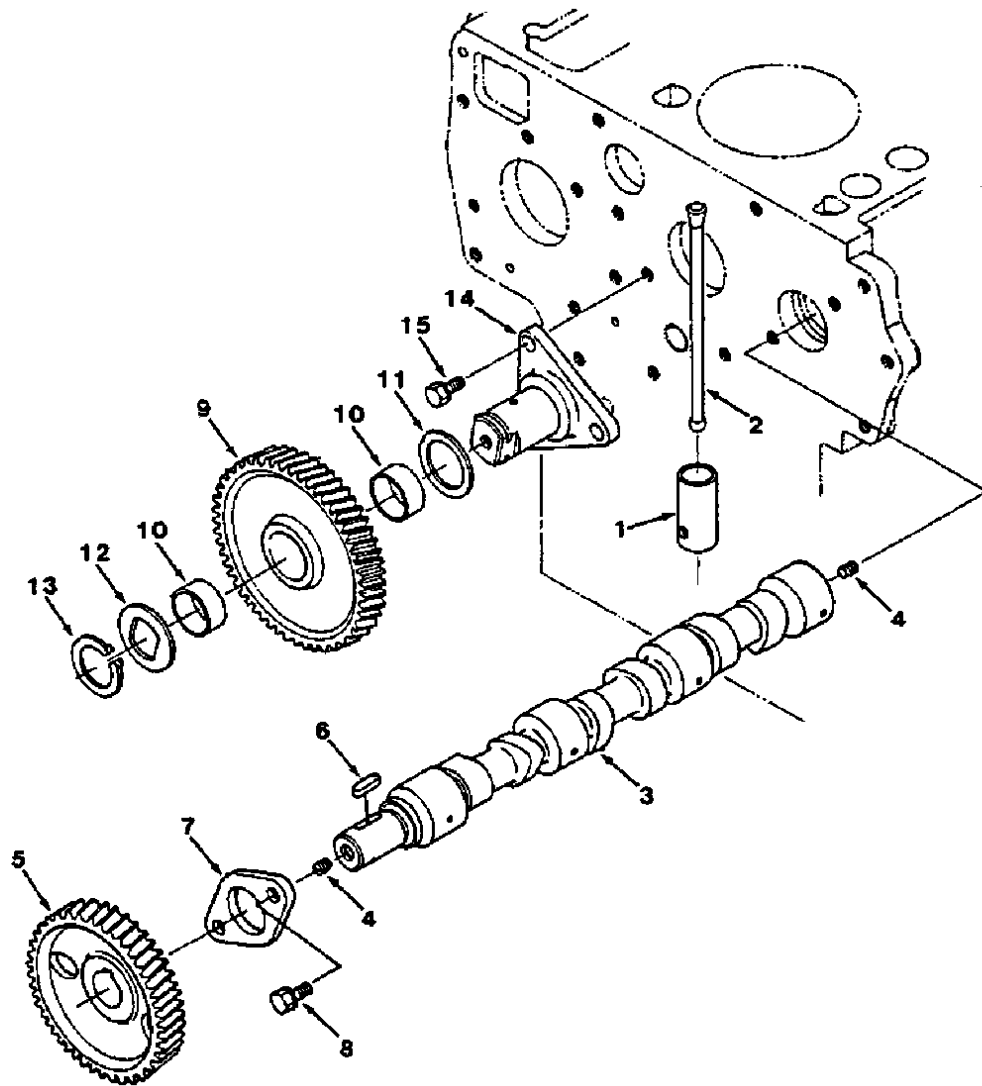

Fig. 10 - Camshaft Group

02692

Key	Tennant® Part No.	Kubota Part Number	Engine Serial Number	Description	Qty.
1		15221-1555-0	(000000-)	Tappet	6
2		15221-1511-0	(000000-)	Rod, Push	6
		15521-1601-0	(000000-)	Camshaft Assembly	1
3		15521-1615-0	(000000-)	Camshaft	1
4		15521-9361-0	(000000-)	Screw, Set	2
5		15521-1651-0	(000000-)	Gear, Camshaft	1
6		05712-00720	(000000-)	Key, Feather	1
7		15221-1627-0	(000000-)	Stopper, Camshaft	1
8		01123-50818	(000000-)	Bolt	2
9		15221-2401-0	(000000-)	Gear Assembly, Idle	1
10		15221-2498-0	(000000-)	Bushing, Idle Gear	2
11		15521-2436-0	(000000-)	Collar	1
12		15521-2437-0	(000000-)	Collar	1
13		15221-2432-0	(000000-)	Cir-Clip, External	1
14		15221-2425-0	(000000-)	Shaft, Idler Gear	1
15		01123-50818	(000000-)	Bolt	3

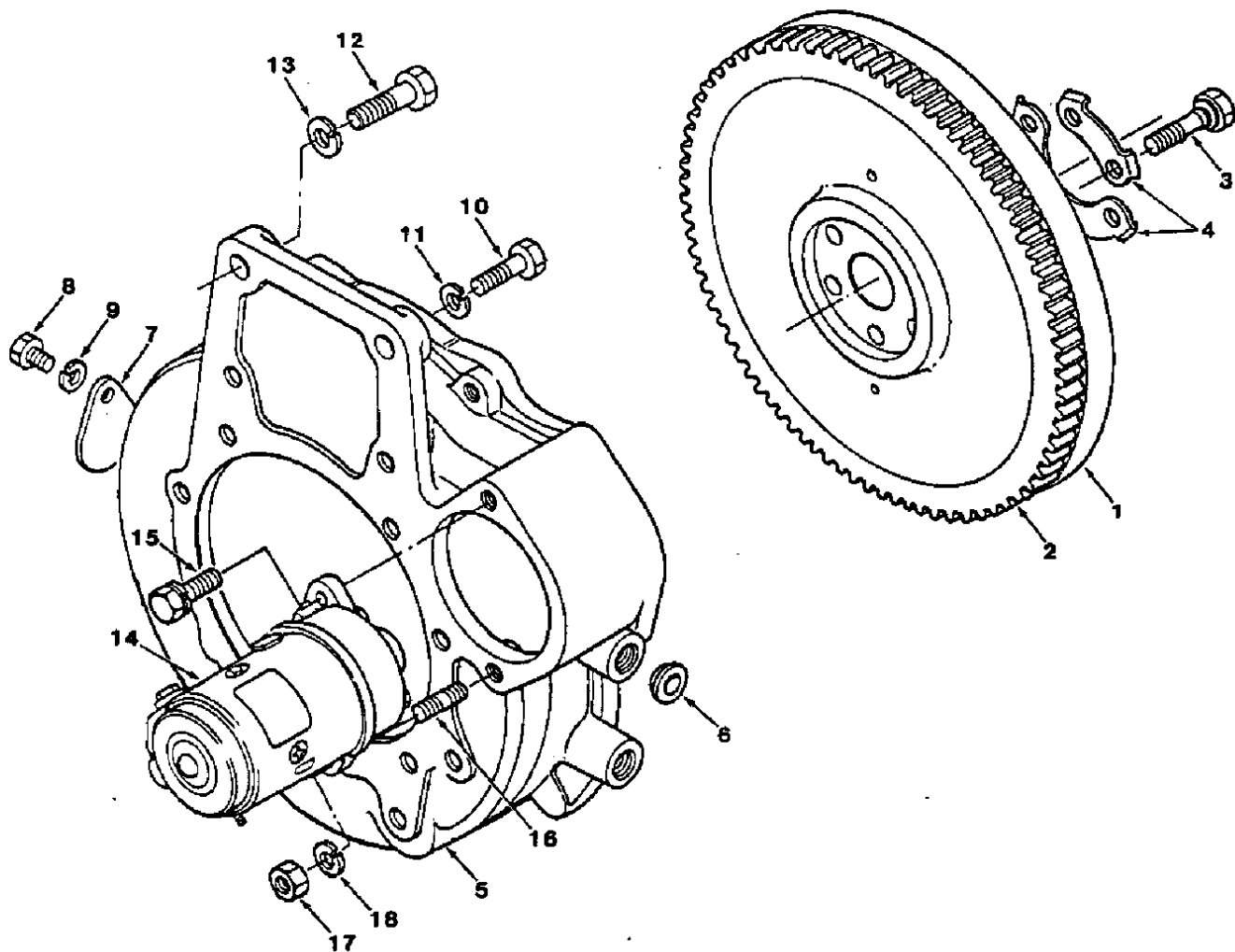

Fig. 11 - Flywheel Group

02694

Key	Tennant® Part No.	Kubota Part Number	Engine Serial Number	Description	Qty.
1		15331-2501-0	(000000-)	Flywheel Assembly	1
2		15221-6382-0	(000000-)	Gear, Ring	1
3		15321-2516-0	(000000-)	Bolt, Flywheel	6
4		15321-2517-0	(000000-)	Washer, Flywheel	3
5		15348-0460-0	(000000-)	Housing Assembly, Flywheel	1
6		31220-1429-0	(000000-)	Plug	4
7		31220-1417-0	(000000-)	Cover	1
8		01153-50812	(000000-)	Bolt	1
9		04512-50080	(000000-)	Washer, Spring	1
10		01073-51030	(000000-)	Bolt	11
11		04512-50100	(000000-)	Washer, Spring	11
12		01073-51240	(000000-)	Bolt	2
13		04512-50120	(000000-)	Washer, Spring	2
14		15521-6301-0	(000000-)	Starter	1
15		01133-51030	(000000-)	Bolt	1
16		01517-51028	(000000-)	Stud	1
17		02176-50100	(000000-)	Nut	1
18		04512-50100	(000000-)	Washer, Spring	1

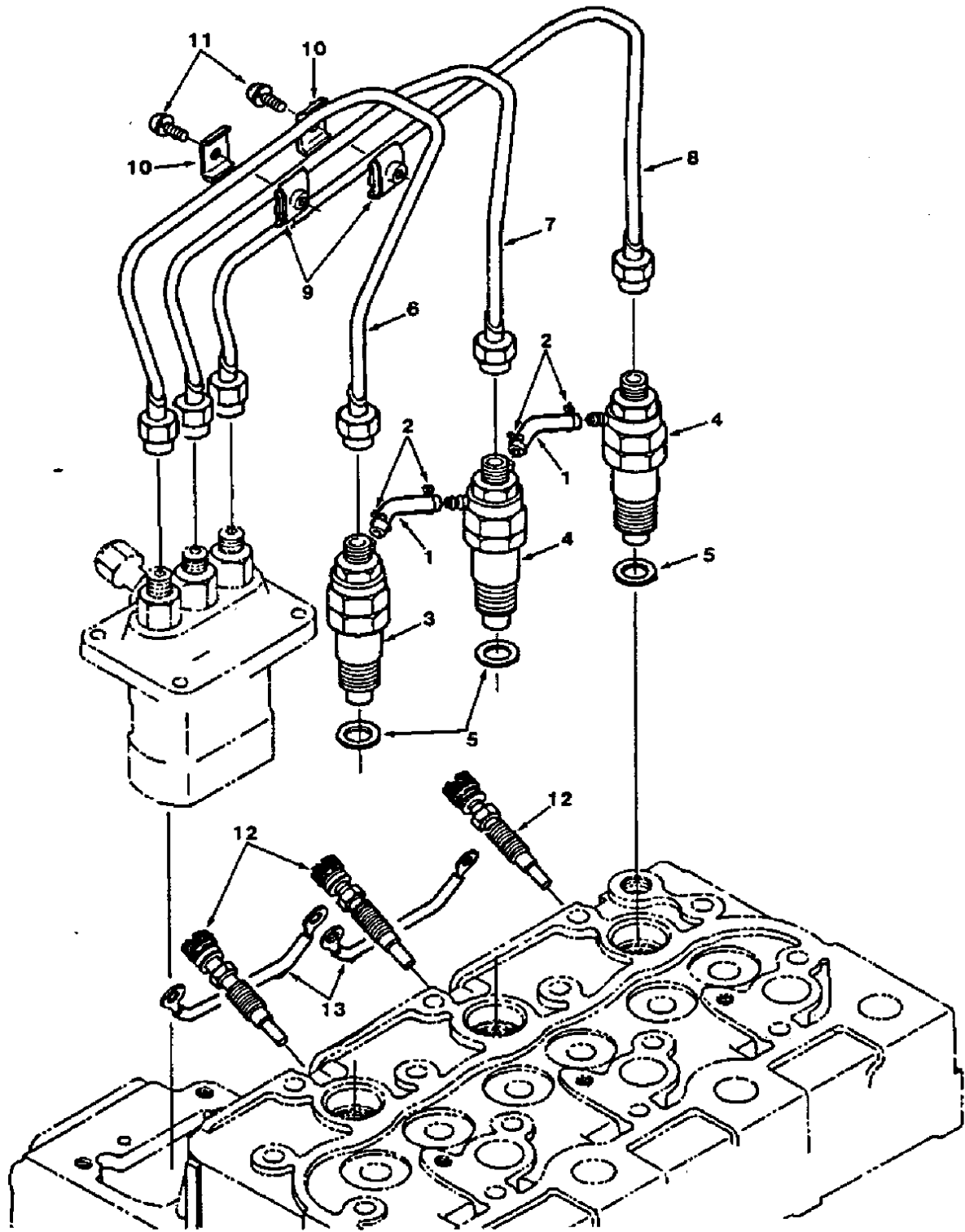

Fig. 12 - Nozzle Group

Fig. 12 - Nozzle Group

02695

Key	Tennant® Part No.	Kubota Part Number	Engine Serial Number	Description	Qty.
1		15221-4251-0	(000000-) Pipe, Fuel Over Flow	2
2		14971-4275-0	(000000-) Clip, Pipe	4
3		15271-5300-0	(000000-) Holder Assembly, Nozzle	1
4		15271-5302-0	(000000-) Holder Assembly, Nozzle	2
5		17011-5362-0	(000000-) Gasket	3
6		15221-5371-0	(000000-) Pipe, Injection	1
7		15221-5372-0	(000000-) Pipe, Injection	1
8		15321-5373-0	(000000-) Pipe, Injection	1
9		15121-5385-0	(000000-) Clamp, Pipe	2
10		15121-5386-0	(000000-) Clamp, Pipe	2
11		03024-50520	(000000-) Screw	2
12		15521-6551-0	(000000-) Glow Plug	3
13		15401-6556-0	(000000-) Cord, Glow Plug	2

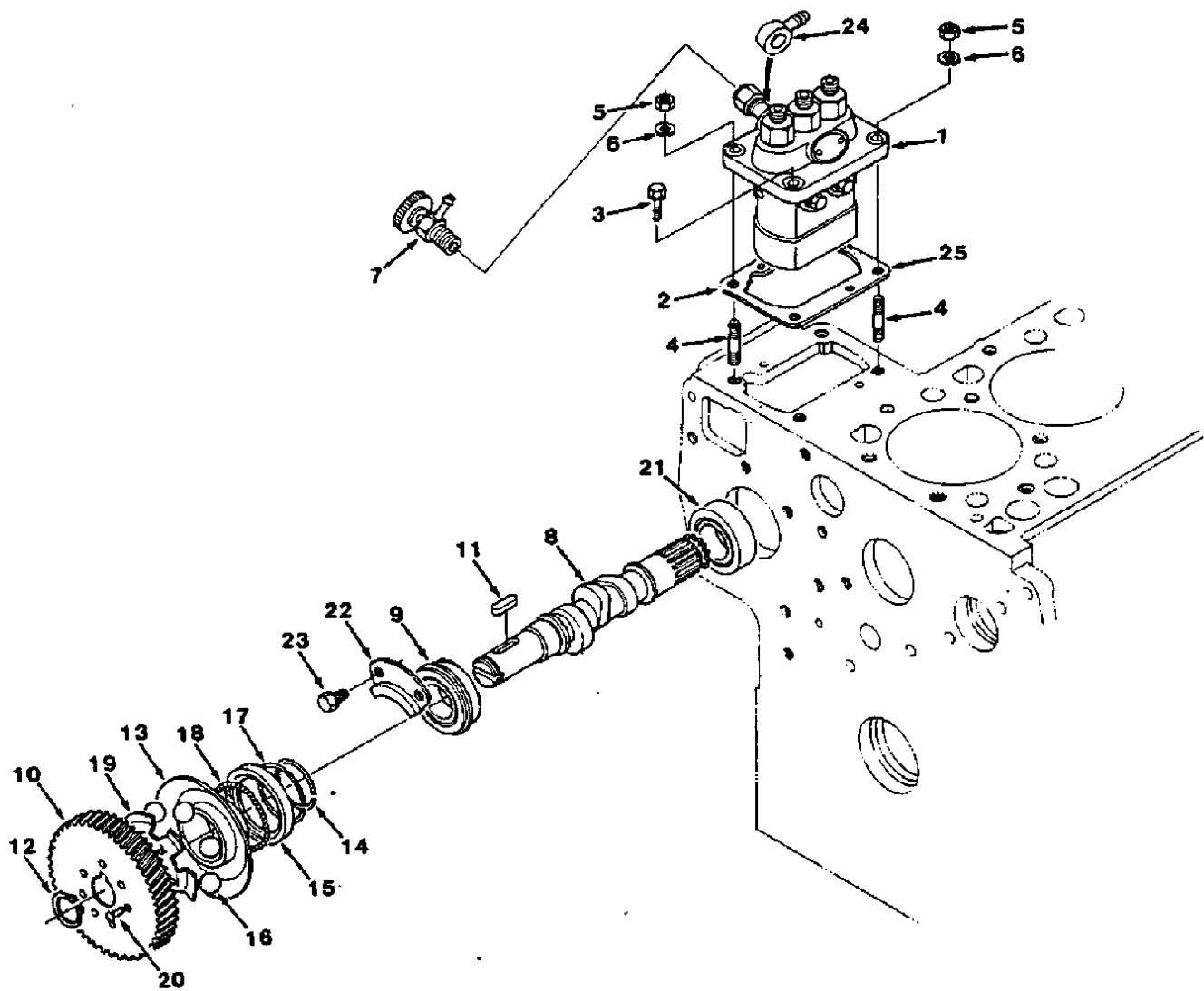

Fig. 13 - Fuel Camshaft Group

Fig. 13 - Fuel Camshaft Group

02595

Key	Tennant® Part No.	Kubota Part Number	Engine Serial Number	Description	Qty.
1		15521-5101-0	(000000-)	Pump Assembly, Injection	1
2		15321-5211-0	(000000-)	Shim, Injection Pump	As Req.
3		01123-50822	(000000-)	Bolt	2
4		01513-50822	(000000-)	Stud	2
5		02156-50080	(000000-)	Nut	2
6		04512-50080	(000000-)	Washer, Spring	2
7		14311-6050-4	(000000-)	Cock Assembly, Jet-Start	1
		15521-1602-0	(000000-)	Camshaft Assembly, Fuel	1
8		15521-1617-0	(000000-)	Camshaft, Fuel	1
9		08153-06205	(000000-)	Bearing, Ball	1
10		15401-5115-0	(000000-)	Gear, Injection Pump	1
11		05712-00525	(000000-)	Key, Feather	1
12		04612-00240	(000000-)	Cir-Clip, External	1
13		15221-5545-0	(000000-)	Sleeve, Governor	1
14		15221-5547-0	(000000-)	Cir-Clip, Sleeve	1
15		15221-5569-0	(000000-)	Case, Governor Ball	1
16		07715-03205	(000000-)	Ball	39
17		15221-5574-0	(000000-)	Cir-Clip, Ball Case	1
18		07715-00805	(000000-)	Ball	7
19		15521-5565-0	(000000-)	Guide, Governor Ball	1
20		05611-10310	(000000-)	Rivet	7
21		08103-06205	(000000-)	Bearing, Ball	1
22		15221-1632-0	(000000-)	Stopper, Fuel Camshaft	1
23		01123-50814	(000000-)	Bolt	2
24		14111-4241-0	(000000-)	Connector	1
25		15521-5211-0	(000000-)	Shim	As Req.

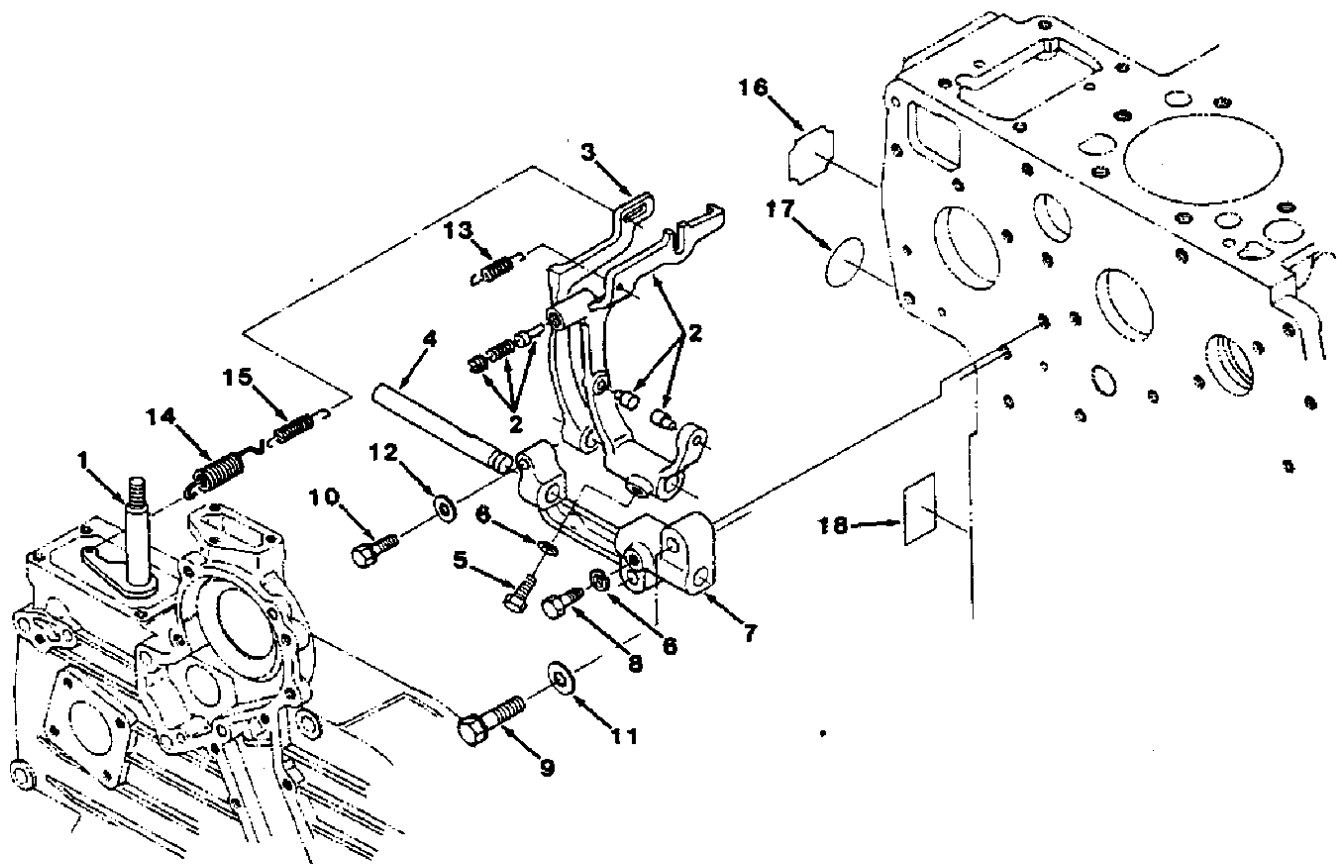

Fig. 14 - Governor Group

02697

Key	Tennant® Part No.	Kubota Part Number	Engine Serial Number	Description	Qty.
1		15601-5602-0	(000000-)	Lever Assembly, Governor	1
		15521-5605-0	(000000-)	Lever Assembly, Fork	1
2		15521-5604-0	(000000-)	Lever Assembly, Fork	1
3		15611-5613-0	(000000-)	Lever, Fork	1
4		15221-5615-0	(000000-)	Shaft, Fork Lever	1
5		15021-5624-0	(000000-)	Bolt, Lever Shaft	1
6		04512-50060	(000000-)	Washer, Spring	2
7		15221-5623-0	(000000-)	Holder, Fork Lever	1
8		15221-6641-0	(000000-)	Bolt	1
9		01123-50832	(000000-)	Bolt	2
10		01023-50628	(000000-)	Bolt	1
11		04012-50080	(000000-)	Washer, Spring	2
12		04012-50060	(000000-)	Washer, Spring	1
13		15601-5648-0	(000000-)	Spring, Start	1
14		15521-5641-0	(000000-)	Spring, Governor	1
15		15521-5642-0	(000000-)	Spring, Governor	1
16		15612-8721-0	(000000-)	Label, Caution	1
17		09999-00002	(000000-)	Label, Inspection	1
18		15103-9459-0	(000000-)	Label, Drain	1

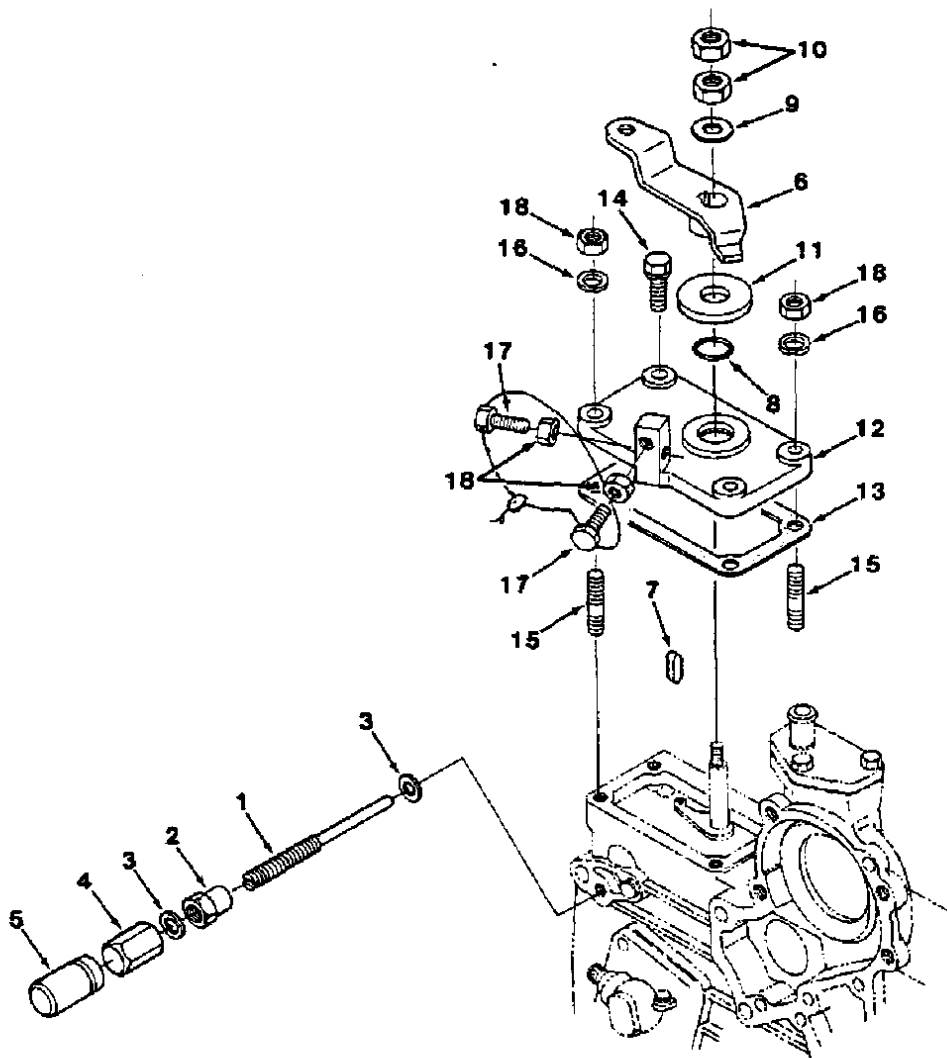

Fig. 15 - Speed Control Plate Group

02698

Key	Tennant® Part No.	Kubota Part Number	Engine Serial Number	Description	Qty.
1		15601-5412-0	(000000-)	Bolt, Adjusting	1
2		15601-9201-0	(000000-)	Nut	1
3		15601-9665-0	(000000-)	Gasket	2
4		15601-5422-0	(000000-)	Nut, Cap	1
5		15601-5442-0	(000000-)	Cap	1
6		15469-5715-0	(000000-)	Lever, Speed Control	1
7		05712-00408	(000000-)	Key, Feather	1
8		04811-00120	(000000-)	O-Ring	1
9		04013-50080	(000000-)	Washer, Plain	1
10		02112-50080	(000000-)	Nut	2
11		17011-5738-0	(000000-)	Plate, Friction	1
12		15521-5711-0	(000000-)	Plate, Speed Control	1
13		15221-5721-0	(000000-)	Gasket, Control Plate	1
14		01023-50620	(000000-)	Bolt	2
15		15221-8821-0	(000000-)	Stud	2
16		04512-50060	(000000-)	Washer, Spring	2
17		15108-5728-0	(000000-)	Stopper	2
18		02056-50060	(000000-)	Nut	4

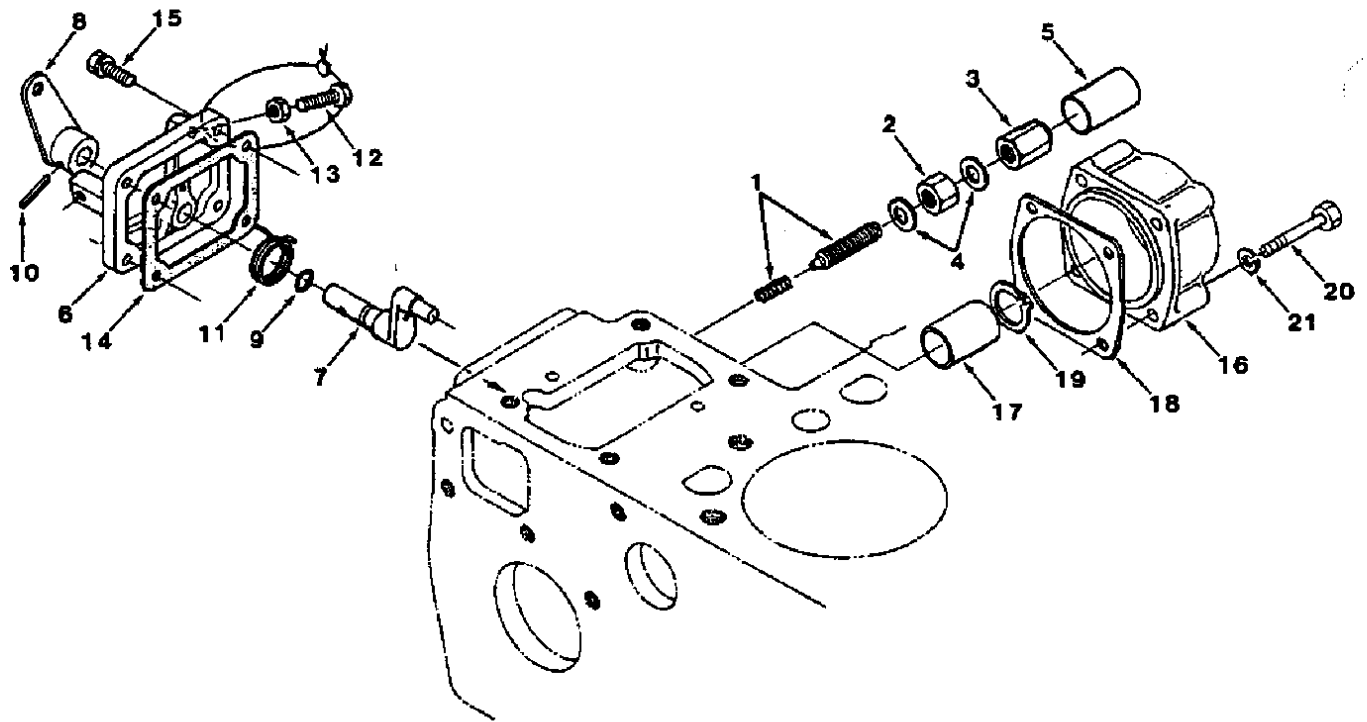

Fig. 16 - Stop Lever Group

02699

Key	Tennant® Part No.	Kubota Part Number	Engine Serial Number	Description	Qty.
		15521-5409-0	(000000-)	Apparatus Assembly, Idle	1
1		15521-5410-0	(000000-)	Bolt Assembly, Adjusting	1
2		15401-9201-0	(000000-)	Nut	1
3		15521-9233-0	(000000-)	Nut, Cap	1
4		15021-3366-0	(000000-)	Gasket	2
5		15521-5427-0	(000000-)	Cap	1
6		15521-5770-0	(000000-)	Lever Assembly, Engine Stop	1
		15521-5165-0	(000000-)	Cover, Injection Pump	1
7		15611-5774-0	(000000-)	Shaft, Lever	1
8		15611-5772-0	(000000-)	Lever, Engine Stop	1
9		04811-10070	(000000-)	O-Ring	1
10		05411-00420	(000000-)	Pin, Spring	1
11		15611-5751-0	(000000-)	Spring	1
12		15108-5728-0	(000000-)	Stopper	1
13		02056-50060	(000000-)	Nut	1
14		15221-5166-0	(000000-)	Gasket, Pump Cover	1
15		01023-50618	(000000-)	Bolt	4
16		15225-1621-0	(000000-)	Cover, Fuel Camshaft	1
17		15225-1619-0	(000000-)	Collar	1
18		34150-3786-0	(000000-)	Packing	1
19		04612-00250	(000000-)	Cir-Clip, External	1
20		01153-50865	(000000-)	Bolt	4
21		04512-50080	(000000-)	Washer, Spring	4

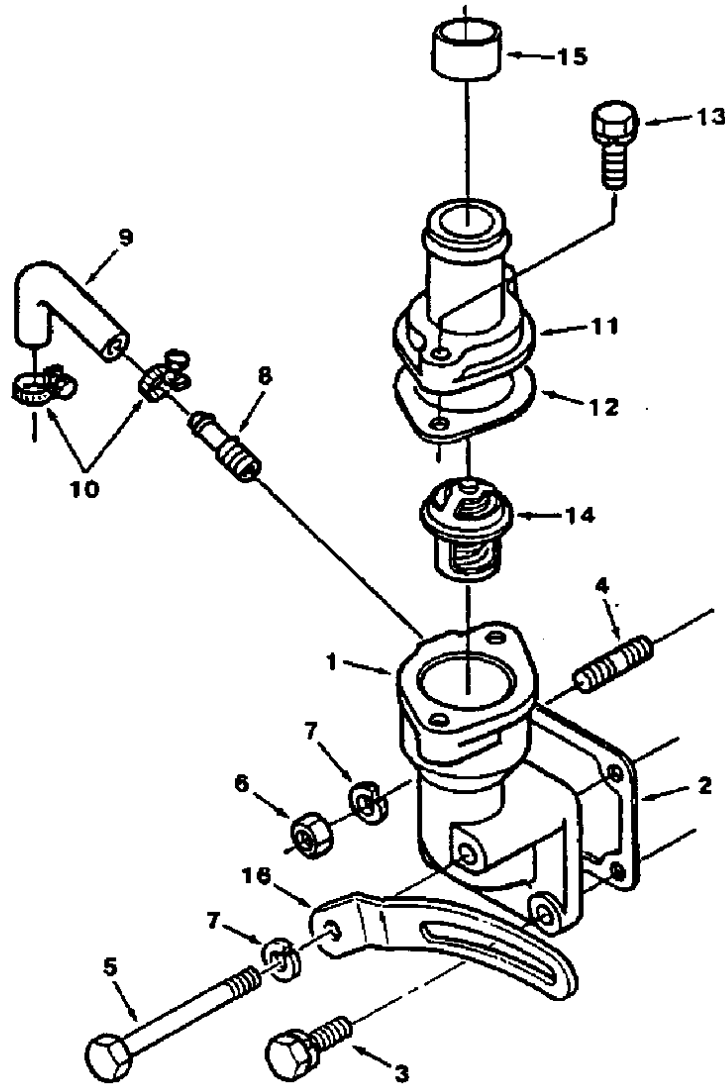

Fig. 17 - Thermostat Group

02700

Key	Tennant® Part No.	Kubota Part Number	Engine Serial Number	Description	Qty.
1		15521-7291-0	(000000-)	Flange, Water	1
2		15521-7292-0	(000000-)	Gasket, Water Flange	1
3		01123-50822	(000000-)	Bolt	2
4		01513-50822	(000000-)	Stud	1
5		01153-50870	(000000-)	Bolt	1
6		02156-50080	(000000-)	Nut	1
7		04512-50080	(000000-)	Washer, Spring	2
8		15321-7334-0	(000000-)	Pipe, Water Return	1
9		15521-7334-0	(000000-)	Pipe, Water Return	1
10		15109-7336-0	(000000-)	Band, Pipe	2
11		15321-7326-0	(000000-)	Cover, Thermostat	1
12		15321-7327-0	(000000-)	Gasket, Thermostat Cover	1
13		01123-50835	(000000-)	Bolt	2
14		15321-7301-0	(000000-)	Thermostat Assembly	1
15		15000-3618-0	(000000-)	Cap	2
16	03254	15321-6442-0	(000000-)	Adjustment, Arm	1

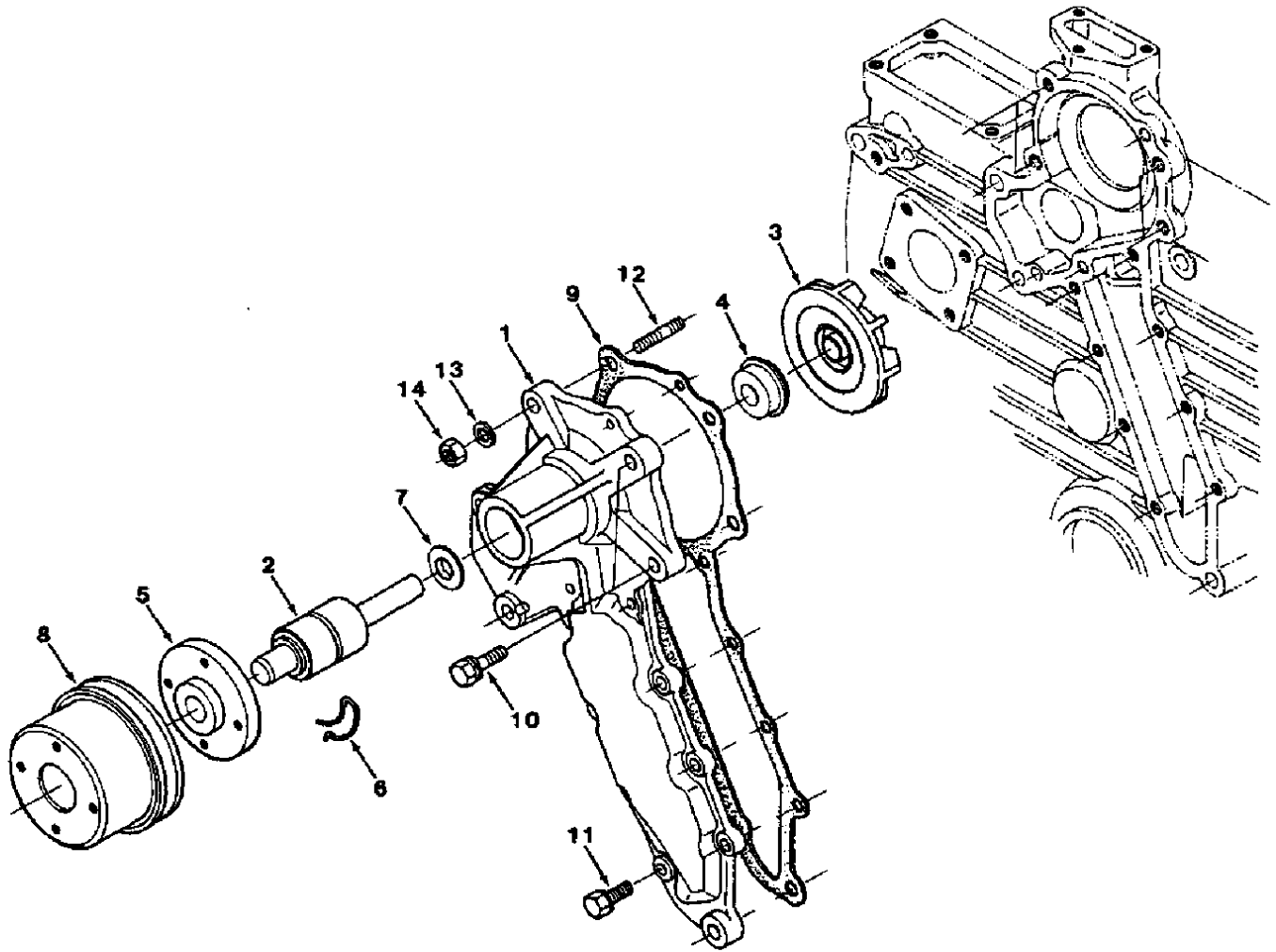

Fig. 18 - Water Pump Group

02701

Key	Tennant® Part No.	Kubota Part Number	Engine Serial Number	Description	Qty.
1		15521-7303-0	(000000-)	Pump Assembly, Water	1
2		15521-7355-0	(000000-)	Bearing	1
3		15321-7351-0	(000000-)	Impeller, Water Pump	1
4		15121-7305-0	(000000-)	Set Seal	1
5		15521-7352-0	(000000-)	Flange, Water Pump Shaft	1
6		15521-9481-0	(000000-)	Pin, Snap	1
7		15121-7362-0	(000000-)	Slinger	1
8		15521-7425-0	(000000-)	Pulley, Fan	1
9		15521-7343-0	(000000-)	Gasket, Water Pump	1
10		01123-50828	(000000-)	Bolt	2
11		01023-50618	(000000-)	Bolt	8
12		01518-50822	(000000-)	Stud	2
13		04512-50080	(000000-)	Washer, Spring	2
14		02156-50080	(000000-)	Nut	2

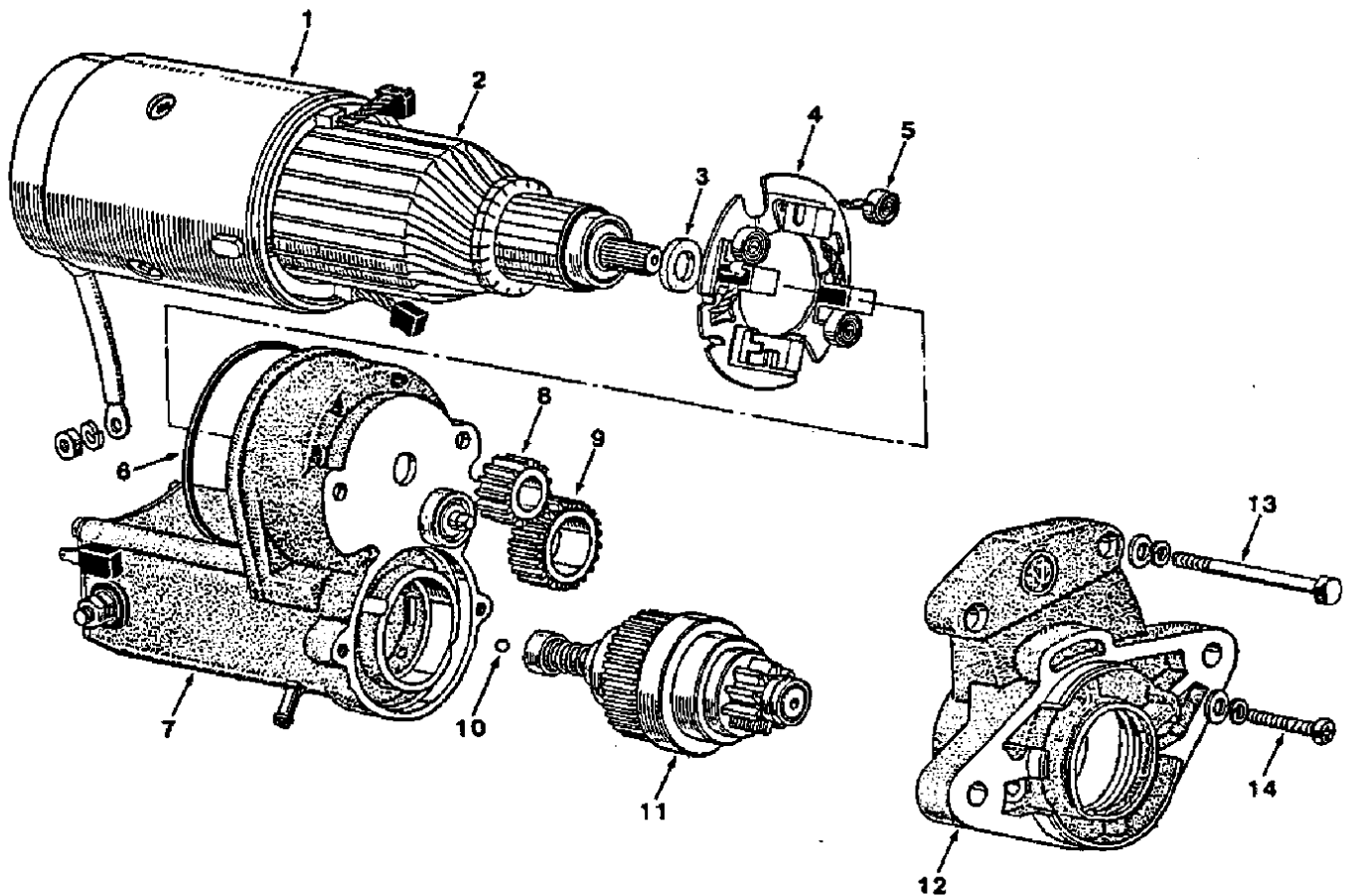

Fig. 19 - Starter Breakdown

02702

Key	Tennant® Part No.	Kubota Part Number	Engine Serial Number	Description	Qty.
1		15521-6301-0	(000000-)	Starter	1
2		15401-6308-0	(000000-)	Yoke	1
3		19212-6307-0	(000000-)	Armature	1
4		19212-9667-0	(000000-)	Gasket	1
5		15401-6338-0	(000000-)	Holder, Brush	1
5		15401-6339-0	(000000-)	Spring, Brush	4
6		15401-9666-0	(000000-)	Gasket	1
7		15521-6302-0	(000000-)	Switch, Magnet	1
8		15521-6326-0	(000000-)	Gear	1
9		15401-6327-0	(000000-)	Gear	1
10		15451-9713-0	(000000-)	Ball	1
11		15521-6304-0	(000000-)	Clutch	1
12		15521-6303-0	(000000-)	Frame, Drive End	1
13		15401-6332-0	(000000-)	Bolt, Through	2
14		15401-9331-0	(000000-)	Screw	2

Home	Find...	Go To..		
------	---------	---------	--	---

TENNANT COMPANY SERVICE LITERATURE AVAILABLE...

A variety of information is available to you in forms to suit your needs. The following is a list of those publications that relate to the Model 275 family of machines:

Machine Model	Publication	Form	Tennant® Part No.
275	Operation, Maintenance, and Parts Manual	Printed	MM151
275	Operation, Maintenance, and Parts Manual	Microfiche	85151
275	Operator Handbook - English, Spanish, French	Printed	MM161
275	Ford KSG-416 Engine Service Manual	Printed	38961

Keep your manuals in a safe, convenient location for your future reference in order to operate, maintain, and order repair parts for your machine. Everyone who operates, maintains, or purchases parts for the machine should have easy access to a copy of the manual.

To get pricing information or to order copies of these publications, contact your nearest Tennant Company parts warehouse, distributor, or sales representative.