



Electronic Service Manuals

This electronic document is provided as a service to our customers. We do not create the contents of the information contained in this document. Should you have detailed questions pertaining to the information contained in this document, you may contact Michco, or the manufacturer which provided the original information in this electronic deliverable. Michco's only part in this electronic deliverable was the electronic assembly process. By providing this manual on line we are not guaranteeing parts availability.

You may contact Michco through the following methods:

Phone (517) 484-9312 or (800) 331-3339

2011 N. High St. -- Lansing, Michigan -- 48906

Fax: (517) 484-9836

Email: CustServe@Michco.com

Web site: www.Michco.Com

Parts Web site: www.FloorMachineParts.Com

Order Parts on Line at:

www.FloorMachineParts.Com

Directly to Parts & Service:

By Email: **Shop@Michco.com**

By Fax: (517) 702-2041

By Voice: Use numbers above.

Serving the Cleaning Industry Since 1922

Notice: All copyrighted material remains property of original owners, all trademarks are property of respective owners. Manuals are subject to Manufacturer's reproduction limitations. Originals or reproductions were provided by manufacturers through a request. We make no warranty as to the correctness of information provided in this document and you assume all risk. By placing these manuals on line we are not declaring our corporation to be an manufacturer authorized dealer or provider, please check our web site for authorized manufacturers we represent.



1520

Electric Automatic Carpet Extractor

Model No.:
607649

Operator and Parts Manual

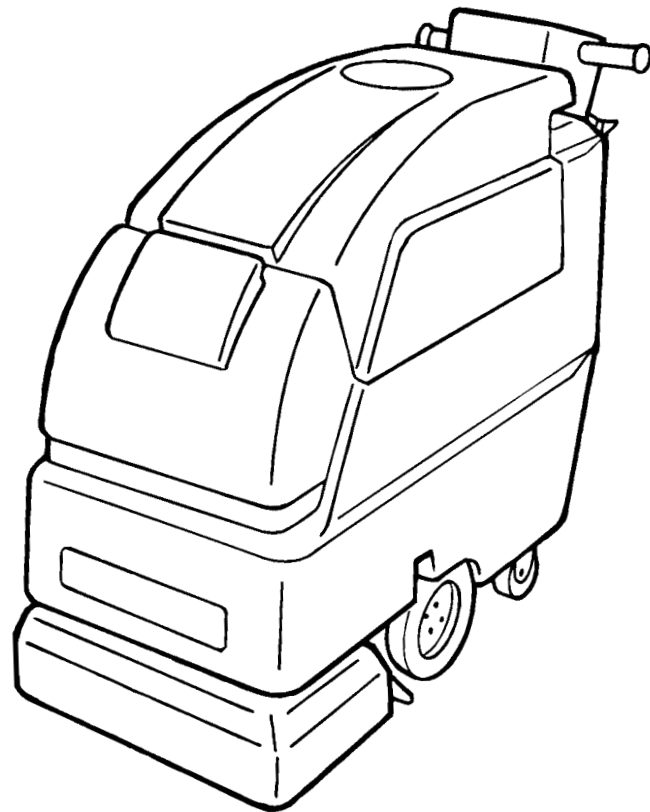

TENNANT COMPANY
Commercial Products
12875 RANSOM STREET
HOLLAND MI 49424 U.S.A.

CUSTOMER SERVICE:
1-800-982-7658
1-616-786-2330

FAX: 1-800-678-4240
1-616-786-3791

607311
Rev. 01 (10-01)

OPERATION

This manual is furnished with each new model. It provides necessary operation and maintenance instructions and an illustrated parts list.

Read this manual completely and understand the machine before operating or servicing it.

When ordering replacement parts use the illustrated Parts Lists in this manual. Before ordering parts or supplies, be sure to have your machine model number and serial number handy. Parts and supplies may be ordered by phone or mail from any authorized Service Center or Distributor.

This machine will provide excellent service. However, the best results will be obtained at minimum costs if:

- The machine is operated with reasonable care.
- The machine is maintained regularly - per the machine maintenance instructions provided.
- The machine is maintained with manufacturer supplied or equivalent parts.

MACHINE DATA

Please fill out at time of installation for future reference.

Model No.- _____

Install. Date - _____

Serial No.- _____

©2001 Tennant Company Printed in U.S.A.

Specifications and parts are subject to change without notice.

TABLE OF CONTENTS

SAFETY PRECAUTIONS	3	RECOMMENDED STOCK ITEMS	11
GROUNDING INSTRUCTIONS	3	TROUBLE SHOOTING	12
MACHINE COMPONENTS	4	SPECIFICATIONS	13
CONTROL PANEL SYMBOLS	4	ELECTRICAL DIAGRAMS	14
MACHINE INSTALLATION	5	WIRE DIAGRAM 120V	14
UNCRATING MACHINE	5	LADDER DIAGRAM 120V	15
MACHINE SETUP	5	PARTS LIST	16
FILLING SOLUTION TANK	5	SOLUTION TANK GROUP	16
ADJUSTING CONTROL GRIP HEIGHT	5	RECOVERY TANK GROUP	18
CONNECTING MACHINE TO		LIFT GROUP	20
POWER SOURCE	5	BRUSH BASE GROUP	22
MACHINE OPERATION	6	DRIVE GROUP	23
PRE-OPERATION CHECKS	6	PLUMBING GROUP	24
WHILE OPERATING MACHINE	7	CONSOLE GROUP	26
CIRCUIT BREAKERS	7	ELECTRICAL GROUP	28
OPTIONAL ACCESSORY TOOL SETUP AND		OPTIONS	29
OPERATION	7	SOLUTION AND VACUUM HOSES	29
DRAINING TANKS	8	127 mm (5 in) HAND TOOL	30
DRAINING RECOVERY TANK	8	76 mm (3 in) CREVICE TOOL	30
DRAINING SOLUTION TANK	9	LOW PRESSURE UPHOLSTERY TOOL ...	31
MACHINE MAINTENANCE	9	330mm (13 in) LOW PRESSURE	
DAILY MAINTENANCE	9	FLOOR TOOL	32
WEEKLY MAINTENANCE	10	406mm (16 in) LOW PRESSURE	
MONTHLY MAINTENANCE	10	FLOOR TOOL	34
QUARTERLY MAINTENANCE	11		
TRANSPORTING MACHINE	11		
STORING MACHINE	11		

SAFETY PRECAUTIONS

This machine is intended for commercial use. It is designed to clean carpets in an indoor environment and is not constructed for any other use. Use only recommended cleaning solutions.

All operators must read, understand, and practice the following safety precautions:

The following safety alert symbols are used throughout this manual as indicated in their descriptions:

⚠ WARNING: To warn of hazards or unsafe practices which could result in severe personal injury or death.

FOR SAFETY: To identify actions which must be followed for safe operation of equipment.

The following information signals potentially dangerous conditions to the operator or equipment:

FOR SAFETY:

1. **Do not operate machine:**
 - Unless trained and authorized.
 - Unless operator manual is read and understood.
 - In flammable or explosive areas.
 - Unless cord is properly grounded.
 - With damaged cord or plug.
 - If not in proper operating condition.
 - In outdoor areas.
 - In standing water.
 - With the use of additional extension cords. Only use manufacturer's extension cord equipped with machine which has proper capacity and is grounded.
2. **Before operating machine:**
 - Make sure all safety devices are in place and operating properly.
3. **When using machine:**
 - Do not run machine over cord.
 - Do not pull machine by plug or cord.
 - Do not pull cord around sharp edges or corners.
 - Do not unplug by pulling on cord.
 - Do not stretch cord.
 - Do not handle plug with wet hands.
 - Keep cord away from heated surfaces.
 - Go slow on inclines and slippery surfaces.
 - Report machine damage or faulty operation immediately.
 - Do not carry riders on machine.

- Follow mixing and handling instructions on chemical containers.

4. Before leaving or servicing machine:

- Stop on level surface.
- Turn off machine.
- Unplug cord from wall outlet.

5. When servicing machine:

- Unplug cord from wall outlet.
- Avoid moving parts. Do not wear loose jackets, shirts, or sleeves.
- Block machine tires before jacking up.
- Use hoist or jack of adequate capacity to lift machine.
- Use manufacturer supplied or approved replacement parts.

⚠ WARNING: Hazardous Voltage. Shock or electrocution can result. Unplug machine before servicing.

⚠ WARNING: Flammable materials can cause an explosion or fire. Do not use flammable materials in tank(s).

⚠ WARNING: Flammable materials or reactive metals can cause an explosion or fire. Do not pick up.

GROUNDING INSTRUCTIONS

Machine must be grounded. If it should malfunction or breakdown, grounding provides a path of least resistance for electrical current to reduce the risk of electrical shock. This machine is equipped with a cord having an equipment-grounding conductor and grounding plug. The plug must be plugged into an appropriate outlet that is properly installed in accordance with all local codes and ordinances. Do not remove ground pin; if missing, replace plug before use.

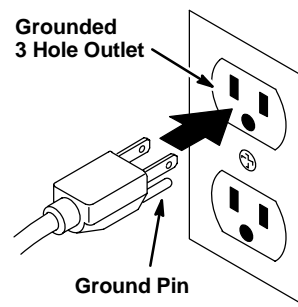





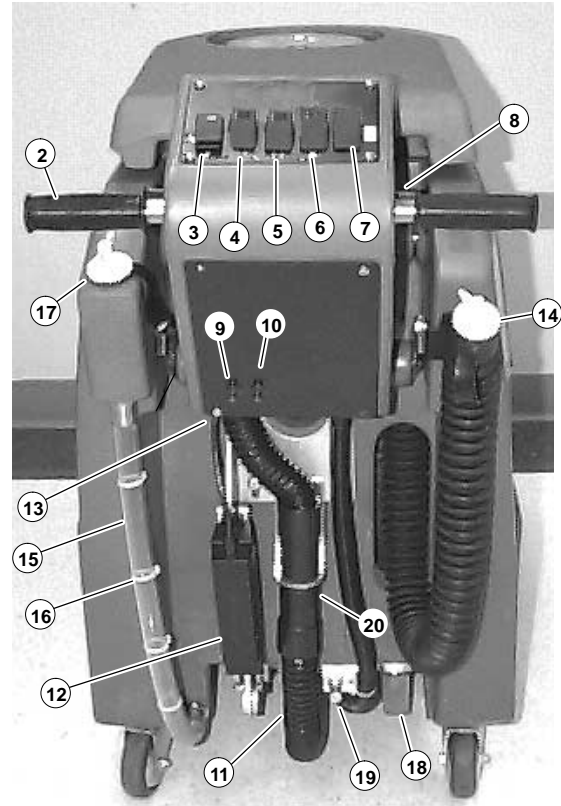





OPERATION

MACHINE COMPONENTS



- | | | |
|-------------------------------------|---------------------------------------|-----------------------------|
| 1. Control Console | 12. Brush/Pickup Head Actuator | 22. Recovery Tank Lid |
| 2. Control Roll Grips | 13. Adjustable Control Console Levers | 23. Solution Tank |
| 3. Main ON/OFF Switch | 14. Recovery Tank Drain Hose | 24. Solution Tank Fill Door |
| 4. Pump ON/OFF Switch | 15. Solution Tank Drain Hose | 25. Drive Wheels |
| 5. Vacuum ON/OFF Switch | 16. 19 L (5 Gal) Increment Markers | 26. Rear Casters |
| 6. Brush/Pickup Head UP/DOWN Switch | 17. Rear Fill Port | 27. Wall Rollers |
| 7. Interim/Restorative Switch | 18. Inline Solution Filter Strainer | 28. Pickup Head |
| 8. Speed Control Knob | 19. Accessory Solution Hose Coupler | 29. Brush Base |
| 9. Brush Motor Circuit Breaker | 20. Accessory Vacuum Hose Connector | N/S. Power Cord (not shown) |
| 10. Drive Motor Circuit Breaker | | |
| 11. Intake Vacuum Hose | | |

CONTROL PANEL SYMBOLS

- | | | | | |
|---|--|--|--|--|
|  Main Power |  Brush Up |  Interim Cleaning |  Fast Speed |  Read Manual Before Operating |
|  Solution Pump |  Brush Down |  Restorative Cleaning |  Slow Speed | |
|  Vacuum | | | | |

MACHINE INSTALLATION

UNCRATING MACHINE

Carefully check carton for signs of damage. Report any damage at once to carrier.

To uncrate your machine, remove shipping straps and carefully lift or make a ramp using crate boards to remove machine from pallet.

ATTENTION: Do not roll machine off pallet, damage may occur.

MACHINE SETUP

FILLING SOLUTION TANK

1. Push machine to filling station. Raise brush/pickup head when transporting.
2. Open solution fill door at front of machine and fill solution tank with up to 98L (26 gal) of clean water, 60°C (140°F) maximum temperature. Or you can use the rear fill port to fill solution tank. Twist off plug and insert hose to fill. The clear tube below the fill port has 19L (5 gal) increment markers to indicate amount of water in tank (Figure 1).



FIG. 1

⚠ WARNING: Flammable materials can cause an explosion or fire. Do not use flammable materials in tank(s).

ATTENTION: If filling with a bucket, be certain that the bucket is clean to prevent solution line clogs.

3. Add the proper amount of cleaning chemical.
NOTE: Pre-spraying chemical by use of a pump-up sprayer may be used as an alternative.

FOR SAFETY: When using machine, follow mixing and handling instructions on chemical containers.

ATTENTION: Use only recommended cleaning chemicals, DO NOT use substitutes. Consult an authorized distributor for recommendations.

ADJUSTING CONTROL GRIP HEIGHT

The machine has three control grip height settings.

1. Locate two spring loaded levers below console.
2. Squeeze levers together and lift or lower control grips to a comfortable operating height (Figure 2).

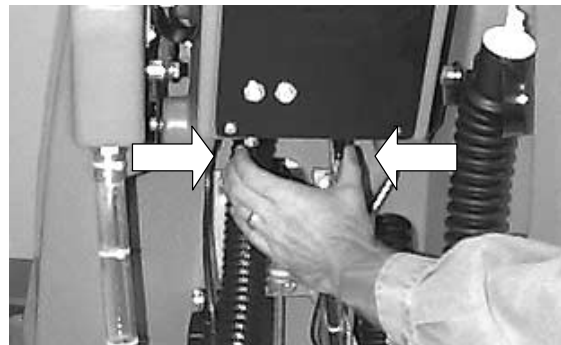

FIG. 2

CONNECTING MACHINE TO POWER SOURCE

1. Connect the 23 m (75 ft) extension cord into the machine's pigtail cord.
2. Plug extension cord into a grounded wall outlet (Figure 3).

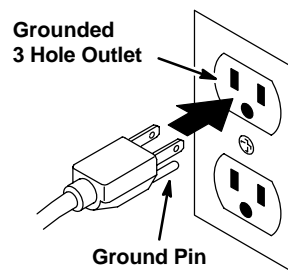

FIG. 3

FOR SAFETY: Do not operate machine unless cord is properly grounded.

FOR SAFETY: Do not operate machine with the use of additional extension cords. Only use manufacturer's extension cord equipped with machine which has proper capacity and is grounded.

3. Attach belt clip to power cord (Figure 4).

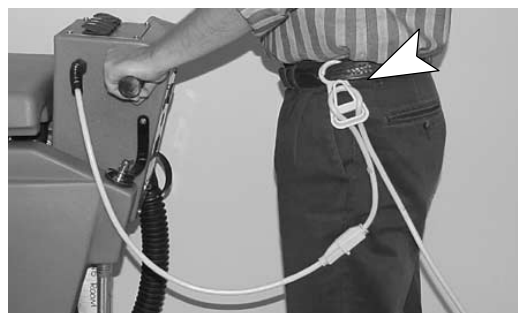

FIG. 4

OPERATION

MACHINE OPERATION

PRE-OPERATION CHECKS

- Vacuum floor and remove any debris.
- Inspect power cord for damage. Make sure power cord is properly grounded.
- Check that spray bar is installed (See Weekly Maintenance).
- Check that inline strainer filter is installed.
- Inspect spray tips for proper spray pattern (See Weekly Maintenance).

FOR SAFETY: Do not operate machine unless operator manual is read and understood.

1. Turn main power switch on.
2. Lower brush to floor by depressing the Brush/Pickup Head UP/DOWN switch (Figure 5).



FIG. 5

3. Position the Interim/Restorative switch to the desired cleaning mode (Figure 6).



FIG. 6



Interim Cleaning Mode: Use this mode for routine carpet surface cleaning. This mode will allow you to operate the machine up to a cleaning pace of approximately 30m (100 ft) per minute.

NOTE: Restorative cleaning must be done on a regular basis in order for interim cleaning to be effective.



Restorative Cleaning Mode: Use this mode for restoring heavily soiled carpet areas. You must operate the machine at a cleaning pace of approximately 15m (50 ft) per minute for optimum cleaning results. Turn the speed control knob just shy of half way for a pace of approximately 15m (50 ft) per minute.

NOTE: The solution flow rate is regulated per cleaning mode. Interim Cleaning Mode = 2.3L (77 oz.) per minute. Restorative Cleaning Mode = 4.1 L (139 oz.) per minute.

4. Turn the vacuum and pump switches on.

NOTE: The brush and pump will start once control grips are rotated.

5. Before you begin cleaning, turn speed control knob to slowest speed (Figure 7).

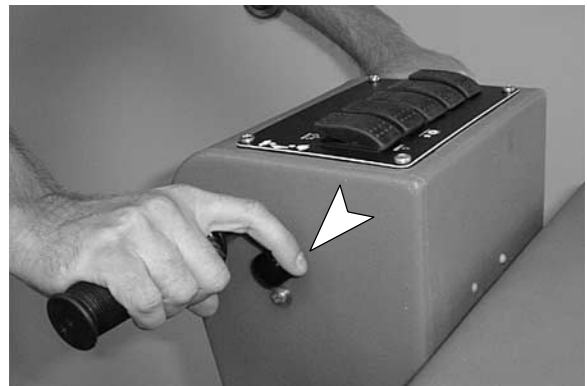

FIG. 7

6. To begin cleaning, rotate control grips completely forward and gradually turn speed control knob to desired cleaning speed (Figure 7).

! WARNING: Flammable materials or reactive metals can cause an explosion or fire. Do not pick up.

7. To stop machine, release control grips.
8. After cleaning carpets, allow sufficient time for carpet to dry. Use a carpet blower to reduce drying time.

WHILE OPERATING MACHINE

1. Periodically check for foam buildup in recovery tank (*look through clear lid*). If excessive foam buildup begins to develop, pour a recommended foam control solution into recovery tank.

ATTENTION: Do not allow foam or water to enter float shut-off screen, vacuum motor damage will result. Foam will not activate float shut-off screen. Vacuum motor damage due to foam or water is not covered under the warranty.

2. Always operate at a slower speed when cleaning around walls or obstacles.
3. Always reduce speed to maintain control when turning machine.
4. Overlap each pass by 50mm (2 in).
5. Before reaching end of cleaning path, turn off pump switch and continue to drive machine forward to extract solution.
6. While cleaning, view clear hose gallon marker for remaining cleaning solution. Each mark on hose indicates 19L (5 gal).
7. When solution tank runs dry, turn off pump and vacuum switches, raise brush, and transport machine to draining area (See Draining Tanks).
8. If the cleaning path leaves streaks, spray tip cleaning is required (See Weekly Maintenance).

⚠ WARNING: Flammable materials or reactive metals can cause an explosion or fire. Do not pick up.

FOR SAFETY: When using machine, do not run machine over cord. Do not pull cord around sharp edges or corners and do not stretch cord.

CIRCUIT BREAKERS

The machine is equipped with two circuit breakers, Drive Motor (4.5 Amp – resettable) and Brush Motor (2.0 Amp – resettable), to protect machine from damage. If a circuit breaker should trip, determine cause, allow motor to cool and then manually reset breaker (Figure 8).

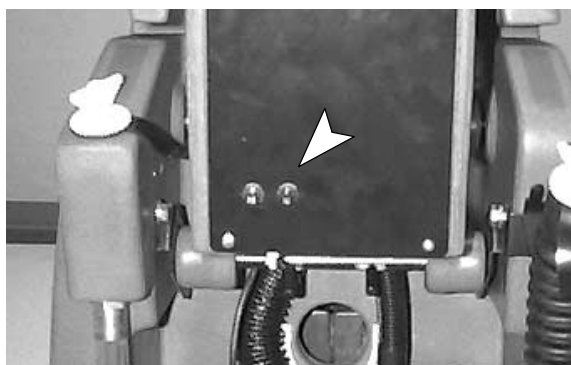

FIG. 8

OPTIONAL ACCESSORY TOOL SETUP AND OPERATION

Machine is equipped with accessory tool connections. Accessory tool enables you to reach areas that the machine is unable, such as alcoves, stairs and corners (See Options at back of manual).

1. Vacuum area before cleaning.
2. Fill solution tank and add cleaning chemical (See Filling Solution Tank). NOTE: Pre-spraying chemical by use of a pump-up sprayer may be used as an alternative.

⚠ WARNING: Flammable materials can cause an explosion or fire. Do not use flammable materials in tank(s).

3. Disconnect lower vacuum hose at rear of machine and replace with accessory vacuum hose (Figure 9).



FIG. 9

4. Connect solution hose to accessory tool coupler, located at lower rear of machine (Figure 10).



FIG. 10

OPERATION

5. Connect accessory tool to solution hose and vacuum hose (Figure 11).

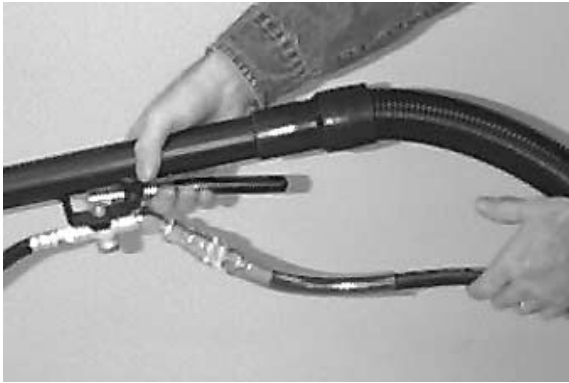

FIG. 11

6. Plug cord into a grounded wall outlet.

FOR SAFETY: Do not operate machine unless cord is properly grounded.

7. Turn on main, pump and vacuum switches.
8. Take accessory tool and begin cleaning at top of area and work backwards toward machine.

⚠ WARNING: Flammable materials or reactive metals can cause an explosion or fire. Do not pick up.

9. Place accessory tool head on area to be cleaned; squeeze trigger, apply downward pressure on accessory tool head, and slowly pull tool backwards. Release trigger 152mm (6 in) from end of stroke (Figure 12).



FIG. 12

10. When returning for next stroke, push accessory tool forward over same path with trigger released. Continue this pull and push method with a 2 to 4 in. overlap of each stroke.

NOTE: For heavily soiled areas, repeat stroke or change angle of stroke.

11. Empty recovery tank when solution tank runs dry (See Draining Tanks).

ATTENTION: Do not allow foam or water to enter vacuum standpipe, vacuum motor damage will result. Float shut-off screen will not keep foam out of standpipe. Vacuum damage due to foam or water is not covered by warranty.

DRAINING TANKS

⚠ WARNING: Hazardous voltage. Shock or electrocution can result. Unplug machine before servicing.

NOTE: Raise brush/pickup head when transporting machine to floor drain.

DRAINING RECOVERY TANK

Always empty recovery tank each time you refill solution tank. To drain recovery tank, perform the following steps:

ATTENTION: If recovery tank is not emptied between fill-ups, foam or water will enter vacuum standpipe and damage vacuum motor. Float shut-off screen will not keep foam out of standpipe.

1. Turn machine off and unplug cord from wall outlet.
2. Remove drain hose from holder, position hose over floor drain and twist off drain hose plug. To completely drain recovery tank, hinge open tank and flip up tank support stand to rest tank on (Figure 13).

NOTE: If using a bucket for filling and draining make sure you use different buckets. This will prevent possible solution line clogs.



FIG. 13

3. Rinse out recovery tank after each use. This will prevent a foul odor and residue buildup in tank. Unscrew clear lid on recovery tank and rinse out the tank with hose. Be careful not to spray water into float shut-off screen.
4. Replace drain hose plug tightly when tank is empty.

DRAINING SOLUTION TANK

To drain leftover cleaning solution from solution tank, follow steps below:

1. Turn machine off and unplug cord from wall outlet.
2. Pull clear hose off hose barb at rear of machine and drain solution into floor drain or bucket (Figure 14).



FIG. 14

3. Rinse out solution tank and solution system with clean water after each use. This will prevent clogging due to chemical buildup. Use clear hose to drain solution tank when rinsing.
4. When reconnecting clear hose to hose barb, be certain hose is completely pushed onto hose barb.

MACHINE MAINTENANCE

To keep machine in good working condition, simply follow the daily, weekly, and monthly maintenance procedures.

⚠ WARNING: Hazardous voltage. Shock or electrocution can result. Unplug machine before servicing.

ATTENTION: Contact an Authorized Service Center for machine repairs. Machine repairs performed by other than an authorized person will void your warranty.

DAILY MAINTENANCE (Every 4 Hours of Operation)

1. Inspect power cord and cord grip for damage. Replace if damaged.
2. Always coil extension cord neatly after each use.
3. Remove float shut-off screen and rinse off. Screen is located in recovery tank (Figure 15).



FIG. 15

4. Drain and rinse tanks thoroughly. After draining tanks, hinge recovery tank open and remove any clogging debris in inlet hole if necessary.
5. Clean machine housing with a nonabrasive, nonsolvent cleaner.
6. Inspect brush for entangled debris.

OPERATION

WEEKLY MAINTENANCE (Every 20 Hours of Operation)

1. Remove inline strainer filter and rinse out. Make sure solution tank is empty before removing filter. Filter is located under machine at rear (Figure 16).

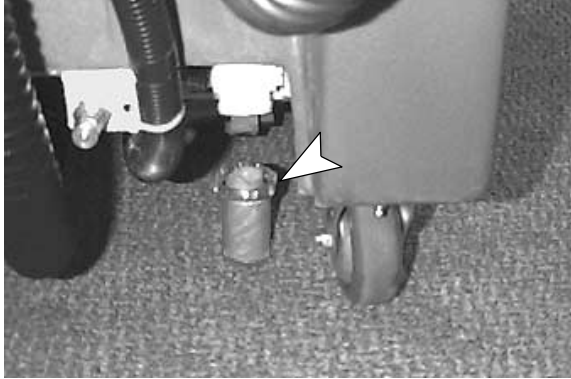

FIG. 16

2. Inspect spray tips for proper spray pattern:
 - a. Lower brush/pickup head and remove detachable spray bar from brush base. Do not disconnect bar from quick coupler. Raise brush after removing spray bar (Figure 17).
 - b. Turn the speed control knob to slowest setting to minimize machine travel during inspection.
 - c. Turn the main power and pump switches on.
 - d. Holding the spray bar off the floor, briefly rotate control grips and observe spray pattern. Pattern should fan out evenly across the width of the spray bar (Figure 17).
 - e. Clean or replace defective twist-out spray tips if necessary (See Monthly Maintenance).



FIG. 17

MONTHLY MAINTENANCE (Every 80 Hours of Operation)

1. Flush chemical buildup from tanks and solution lines. Follow procedure below:
 - a. Drain all water from machine.
 - b. Over a floor drain, carefully jack up the machine so the drive wheels are just off the floor. Use a block of wood for jacking. Make sure to stay clear of the brush area when jacking (Figure 18). The machine drive wheels must spin freely during the flushing procedure.

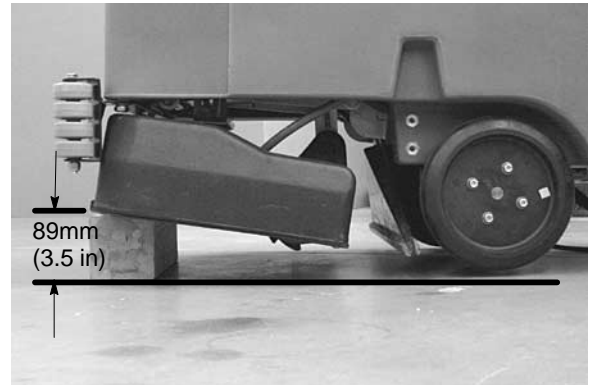

FIG. 18

- c. Pour 750 ml (24 oz) of an acetic acid solution with 11.3 ltr (3 gal) of hot water into solution tank; do not exceed 60°C (140°F).

FOR SAFETY: When using machine, follow mixing and handling instructions on chemical containers.

⚠ WARNING: Flammable materials can cause an explosion or fire. Do not use flammable materials in tank(s).

- d. Turn on the main and pump switches and select the Restorative Cleaning Mode.
- e. Rotate the control grips and hold for one to two minutes. As a safety precaution, turn the speed control knob to the slowest setting.
- f. Shut off power, unplug machine and let machine set overnight to allow acetic acid solution to breakdown chemical buildup.
- g. Next day, while machine is still jacked up, disperse remaining acetic acid solution.
- h. Then rinse out solution tank and solution lines with clean water.

- Remove detachable spray bar from brush base. Remove twist-out spray tips from spray bar and soak in 118ml (4 oz) acetic acid solution for up to 6 hours. After soaking tips, use a small brush to remove excess alkaline and rinse thoroughly. DO NOT use pointed objects to unplug spray tips (Figure 19).



FIG. 19

- Lubricate caster grease fittings with a water resistant grease.
- Lubricate all linkage pivot points with silicone spray, then coat with a water resistant grease to maintain a smooth operation.
- Check machine for water leaks and loose nuts and bolts.

QUARTERLY MAINTENANCE (Every 250 Hours of Operation)

Check drive and vacuum motors for carbon brush wear, replace brushes if worn to a length of 10mm (0.38 in) or less.

Contact an Authorized Service Center for motor maintenance.

TRANSPORTING MACHINE

When transporting machine by use of trailer or truck, be certain to follow tie-down procedures below:

FOR SAFETY: When using machine, go slow on inclines and slippery surfaces.

- Raise brush/pickup head.
- Carefully load machine using a recommended loading ramp.
- Position front of machine up against front of trailer or truck. Place a block behind each drive wheel to prevent machine from rolling.

- Secure machine with tie-down straps. It may be necessary to install tie-down brackets to the floor of your trailer or truck.

NOTE: Do not use the control grips to secure machine for transporting.

STORING MACHINE

- Before storing machine, rinse tanks and drain machine of all water.
- Store machine in a dry area.
- Remove recovery lid to promote air circulation.
- Raise the brush/pickup head off the floor.
- If storing machine in freezing temperatures, be certain to circulate an undiluted anti-freeze solution throughout the machine.

ATTENTION: Do not allow machine to freeze without antifreeze. Damage due to freezing temperatures is not covered by warranty.

ATTENTION: Do not expose machine to rain and store indoors.

RECOMMENDED STOCK ITEMS

Refer to Parts List section for recommended stock items. Stock Items are clearly identified with a bullet preceding the parts description. See example below:

Ref.	Part No.	Description	Qty.
1	701103	ASM., STANDPIPE	1
2	180613	●FLOAT, SHUTOFF	1
3	230187	NIPPLE	1
4	101714	●GASKET	1
5	210240	NUT, FLANGED	1

OPERATION

TROUBLE SHOOTING

PROBLEM	CAUSE	SOLUTION
No power	Faulty main power switch.	Contact Service Center.
	Power cord disconnected.	Connect power cord.
	Faulty power supply cord.	Replace power supply cord.
	Building circuit breaker has tripped.	Determine cause and reset circuit breaker in building.
Brush motor does not operate	Pump switch is not activated.	Turn on pump switch.
	Control grips are not rotated.	Rotate control grips.
	Brush circuit breaker has tripped.	Remove obstruction from brush and reset brush circuit breaker button.
	Faulty brush motor or wiring.	Contact Service Center.
	Carbon brushes worn.	Contact Service Center.
	Loose or broken belt.	Replace, or contact Service Center.
Vacuum motor does not operate	Faulty vacuum switch.	Contact Service Center.
	Vacuum motor thermal overload activated.	Remove obstruction and wait 20 minutes for motor to cool.
	Faulty vacuum motor or wiring.	Contact Service Center.
	Carbon brushes worn.	Contact Service Center.
Drive motor does not operate	Drive motor circuit breaker has tripped.	Determine cause and reset breaker.
	Faulty speed control board or connection.	Contact Service Center.
	Faulty drive motor.	Contact Service Center.
	Faulty wiring.	Contact Service Center.
	Worn carbon brushes.	Contact Service Center.
Drive motor operates, but not correctly	Faulty potentiometer or speed control board.	Contact Service Center.
	Loose wire connection.	Contact Service Center.
Uneven or no solution spray	Twist-out spray tips are plugged.	Remove and clean.
	Control grips are not rotated.	Rotate control grips.
	Solution line or solution tank filter is clogged.	Remove hose and blow compressed air through it. Flush solution tank after each use.
	Inline strainer filter is plugged.	Drain solution tank, remove filter and clean. Located under machine at rear.
	Faulty pump switch.	Contact Service Center.
	Faulty pump or solenoid.	Contact Service Center.

TROUBLE SHOOTING –Continued

PROBLEM	CAUSE	SOLUTION
Poor vacuum recovery	Recovery tank is full.	Empty recovery tank.
	Float shut-off screen inside recovery tank is clogged.	Remove screen and clean.
	Pickup head is clogged with debris.	Remove debris, use coat hanger.
	Pickup head is not sealed to carpet.	Adjust pickup head.
	Faulty actuator.	Contact Service Center.
	Vacuum hose connections are loose or hose has a hole.	Push hose cuffs firmly on connections. Replace hose if damaged.
	Vacuum hose is clogged with debris.	Remove clogged debris.
	Recovery tank inlet hole is obstructed.	Empty recovery tank and tilt tank sideways to access inlet hole, remove obstruction.
	Tank gasket is defective.	Replace gasket.
	Drain hose plug is loose.	Tighten drain plug.
	Recovery tank lid is loose.	Tighten lid.
	Vacuum motor is loose.	Contact Service Center.

SPECIFICATIONS

MODEL	1520
LENGTH	1270 mm (50 in)
WIDTH	559 mm (22 in)
HEIGHT	990 mm (39 in)
WEIGHT	124 Kg (273.5 lb)
SOLUTION TANK CAPACITY	98 L (26 Gal)
RECOVERY TANK CAPACITY	64 L (17 Gal)
SPEED CONTROL	Variable Fwd.
CLEANING SPEED (MAX)	418.05 m ² (4,500 sq ft) per hour (Interim Cleaning Mode)
CLEANING PATH WIDTH	559 mm (22 in)
PAD PRESSURE	Variable 36–68 Kg (80–150 lb)
SOLUTION PUMP	6.9 bar (100 psi) max., 120V
SOLUTION FLOW RATES	Interim Cleaning Mode = 2.3L (77 oz.) per minute. Restorative Cleaning Mode= 4.1 L (139 oz.) per minute.
DRIVE SYSTEM	Transaxle, .2 hp, 72 rpm, 120V
BRUSH MOTOR	.12hp, 1800 rpm, 120V, .75A, 90W
VACUUM MOTOR	1.8hp, 3–stage 5.7 in, 120V, 11A, 1320W
WATER LIFT	3048 mm (120 in)
DECIBEL RATING AT OPERATOR'S EAR, INDOORS ON CARPET	84dB(A)
POWER CORD LENGTH	23 m (75 ft)

WIRE DIAGRAM 120V

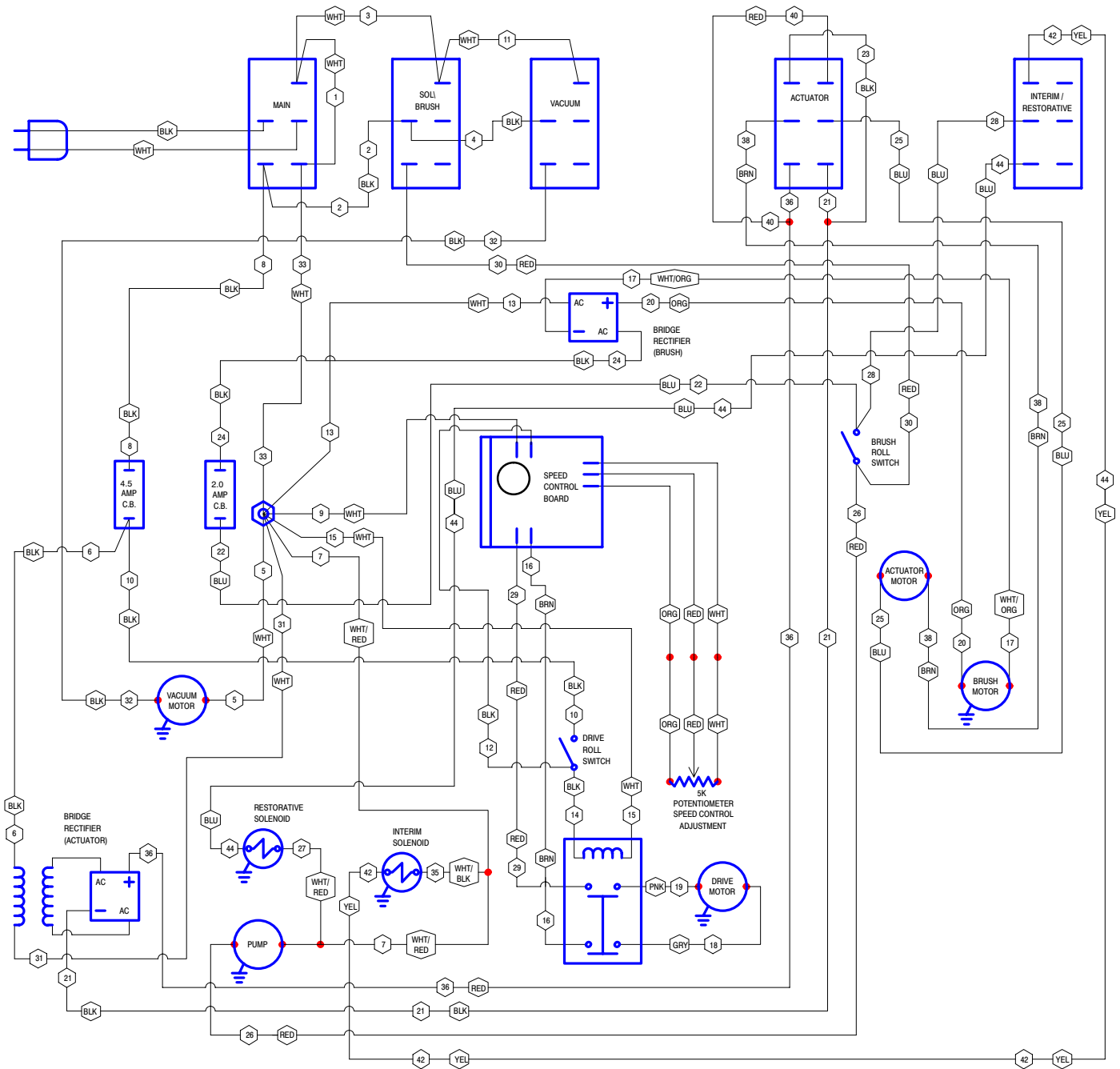

LADDER DIAGRAM 120V

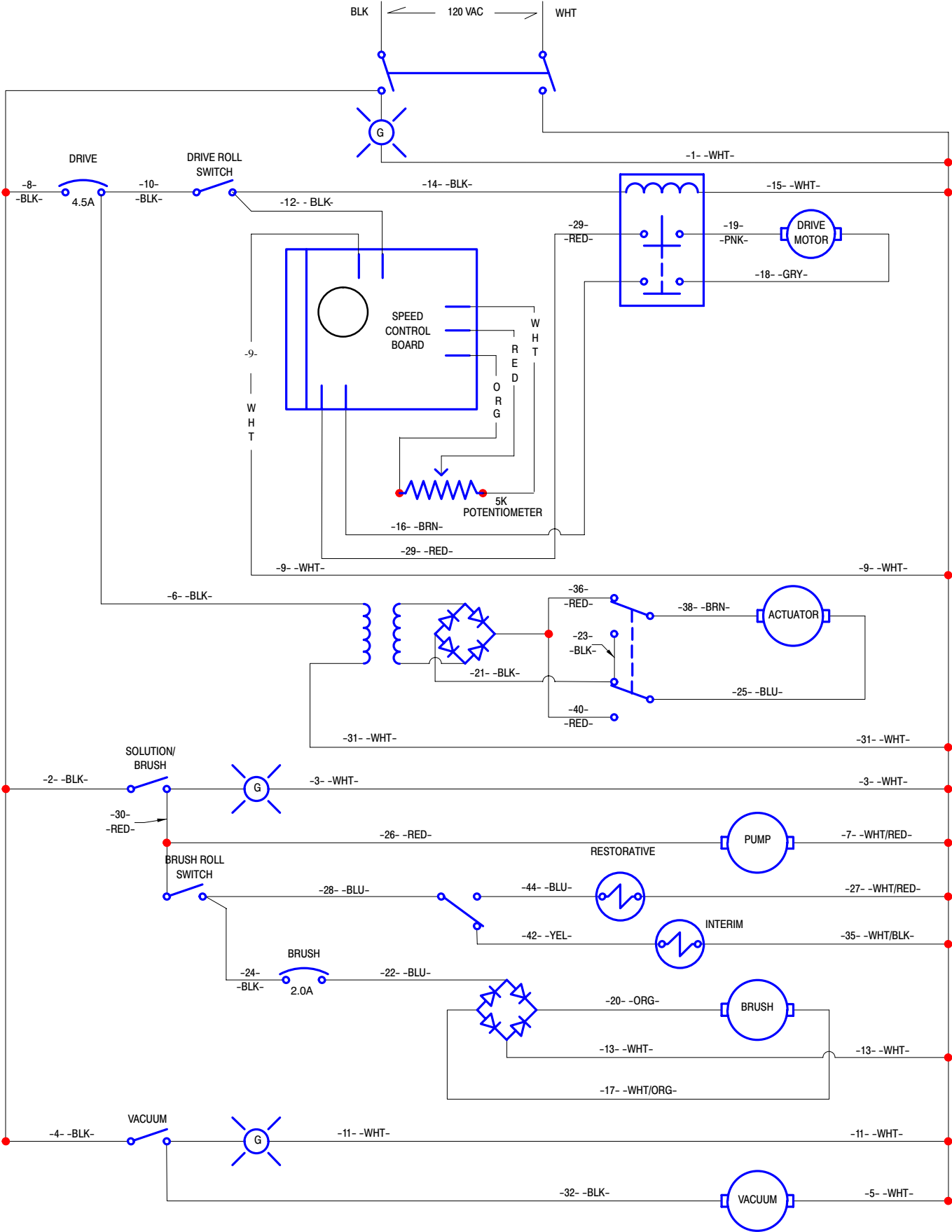

SOLUTION TANK GROUP

REF	PART #	DESCRIPTION	QTY.
1	607515	COVER, TANK, TEAL	1
2	611068	HINGE, COVER	1
3	140706	RIVET, POP	7
4	602529	SCREEN, FILL	1
5	3701.6	SCREW, #6X3/4	2
6	140032	WASHER, FLAT #6	2
7	230661	PLATE, LOCK CONTROL HOUSING	2
8	611979	WELDMENT, DRAIN HOSE	1
9	140027	WASHER, FLAT 5/16	3
10	140015	WASHER, LOCK 5/16	3
11	200031488	SCREW, M8X20MM	3
12	604308	TANK, SOLUTION 10GAL	1
13	630010	●GASKET	1
14	630011	TUBE, ADAPTER	1
15	630267	SPRING, COMP	1
16	630016	RING, RETAINING	1
17	608706	BRACKET, VAC TUBE	1
18	150516	FITTING, 1/4MX3/8H BARB	2
19	140310	CLAMP, HOSE 5/16 – 7/8	2
20	607308	HOSE, 3/8" X 8"	1
21	604265	COUNTERWEIGHT 34LBS	1
22	611418	SLEEVE	1

REF	PART #	DESCRIPTION	QTY.
23	230925	SUPPORT, RECOVERY TANK	1
24	600476	STRAP, PLUG	1
25	621324	●PLUG, EXPANSION	1
26	140011	WASHER, FLAT 3/16	1
27	140350	SCREW, #10X1/2	1
28	608154	DECAL, 1520	2
29	607552	TANK, SOLUTION, TEAL	1
30	150529	FITTING, 3/4MX3/4H	2
31	607983	HOSE, W/LEVEL INDICATORS	1
32	608915	CLAMP, HOSE 2 WIRE	1
33	612056	CASTER 4"	2
34	140036	WASHER, FLAT 3/8	8
35	140333	WASHER, LOCK M10	8
36	140277	SCREW, M10X20MM	8
37	150419	ELBOW, 1/4M X 3/8H 90°	2
38	140310	CLAMP	2
39	607310	HOSE, 3/8" X 17.5"	1
40	600730	DECAL, RECESS	1
41	120192	DECAL, "TENNANT"	1
42	150530	FITTING, 1"MX1-1/4H BARB	2
43	608915	CLAMP, HOSE 2 WIRE	2
44	604279	HOSE, DRAIN	1

● RECOMMENDED STOCK ITEMS

RECOVERY TANK GROUP

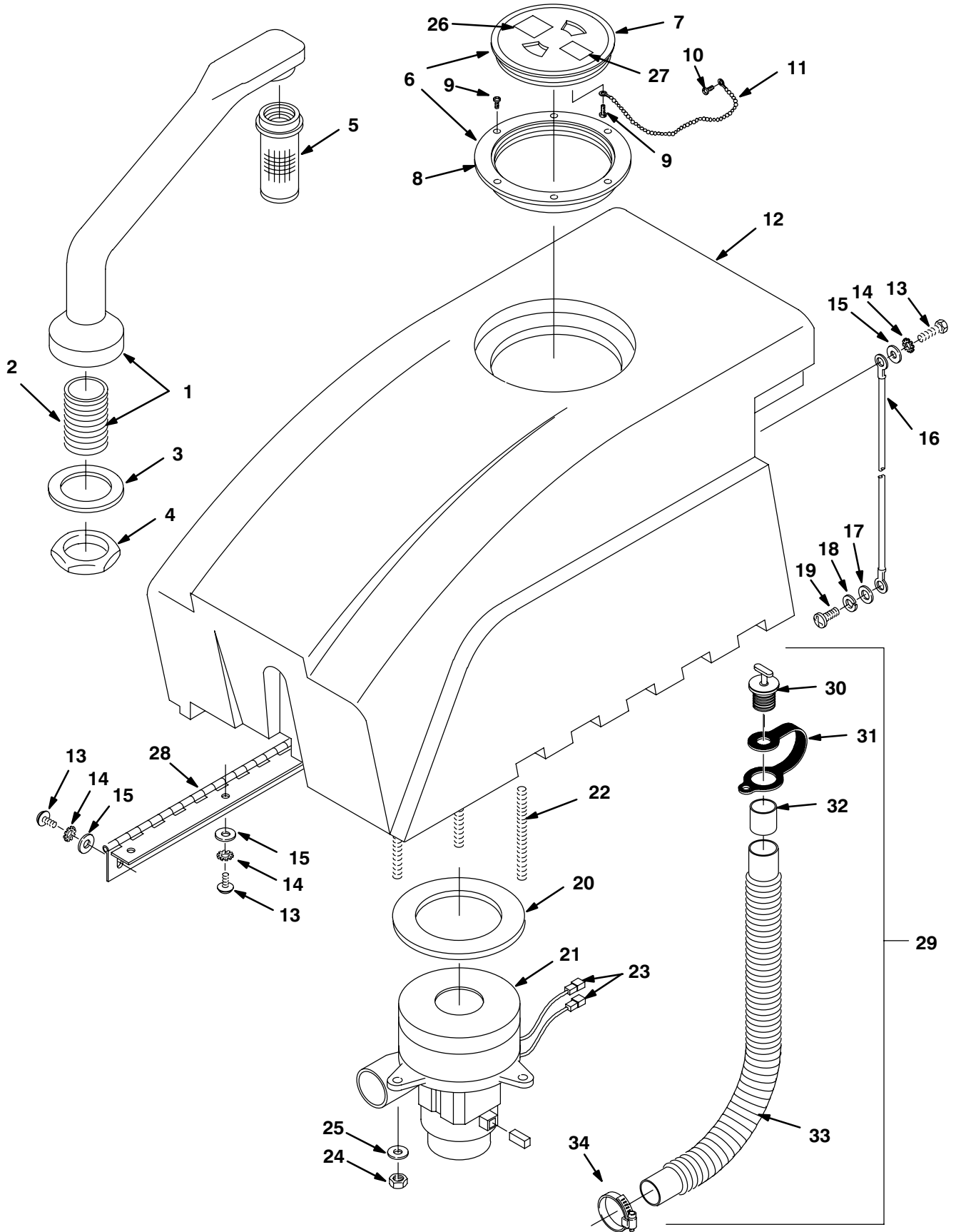

RECOVERY TANK GROUP

REF	PART #	DESCRIPTION	QTY.
▽ 1	701103	ASM., STANDPIPE	1
▲ 2	606088	NIPPLE	1
3	101714	●GASKET	1
4	210240	NUT, FLANGED	1
5	180613	●FLOAT, SHUT-OFF	1
▽ 6	100102	●ASM., LID CLEAR W/STD HOLE	1
▲ 7	100105	●LID, CENTER CLEAR ONLY	1
▲ 8	100109	●LID, OUTER RING ONLY	1
9	140826	SCREW, #6X3/4	7
10	3701.6	SCREW, #6X3/8	1
11	230513	ASM., CHAIN	1
12	607554	TANK, RECOVERY, TEAL	1
13	578187000	SCREW, M6X12MM	12
14	140052	WASHER, LOCK 1/4	12
15	140000	WASHER, FLAT 1/4	15
16	140960	CABLE, SUPPORT	1
17	140027	WASHER, FLAT 5/16	1
18	140015	WASHER, LOCK 5/16	1

REF	PART #	DESCRIPTION	QTY.
19	200031488	SCREW, M8X20MM	1
20	100038	●GASKET, VAC MOTOR	1
21	130996	●MOTOR, VAC 5.7 /3 STAGE 120V	1
	602741	CARBON BRUSH, SET OF 2	2
22	140353	M6X108 STUD	3
23	130133	TERMINAL, MALE DSCNT	2
24	140284	NUT, M6	3
25	140000	WASHER, FLAT	3
26	120906	DECAL, IMPORTANT DRAIN...	1
27	578729	DECAL, READ MANUAL	1
28	600311	●HINGE, RECOVERY TANK	1
▽ 29	603217	ASM., DRAIN HOSE	1
▲ 30	621324	PLUG, EXPANSION	1
▲ 31	578441	STRAP	1
▲ 32	630394	SLEEVE	1
▲ 33	630068	HOSE, DRAIN	1
▲ 34	140308	CLAMP	1

▽ ASSEMBLY

▲ INCLUDED IN ASSEMBLY

● RECOMMENDED STOCK ITEMS

LIFT GROUP

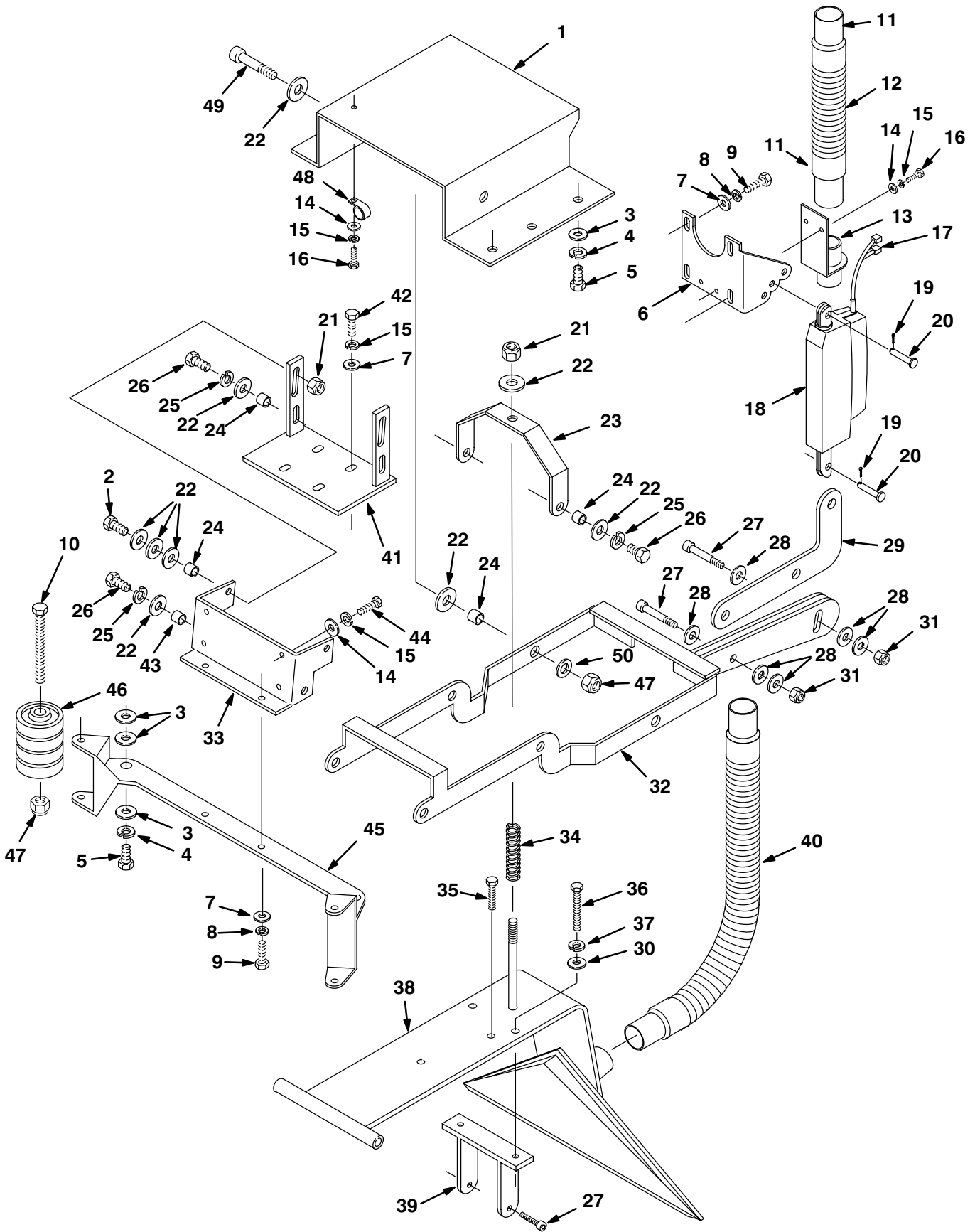

LIFT GROUP

REF	PART #	DESCRIPTION	QTY.
1	612782	PLATE, BASE TRANSAXLE	1
2	140236	SCREW, 1/2-13X1 1/4	2
3	140028	WASHER, FLAT	8
4	140333	WASHER, LOCK	4
5	140277	SCREW, M10X1.5X20MM	4
6	600292	BRACKET, ACTUATOR	1
7	140027	WASHER, FLAT	10
8	140015	WASHER, LOCK	8
9	200031488	SCREW, M08X20MM	8
10	590248	SCREW, 38-16X4.75	2
11	160486	●CUFF, HOSE	1
12	160426	●HOSE, VAC 1.5X15" W/CUFF	1
13	603084	BRACKET, VAC HOSE	1
14	140000	WASHER, FLAT	3
15	140016	WASHER, LOCK	11
16	200031432	SCREW, M06X10MM	3
17	130129	TERMINAL, FM DSCNT 22-18 RED	2
18	600952	●ACTUATOR, 24VDC	1
19	604076	PIN, CLEVIS	2
20	578421	PIN, COTTER	2
21	140516	NUT, NYLOCK	3
22	140045	WASHER, FLAT	17
23	602567	BRACKET, SPRING	1
24	602882	BUSHING	8
25	140024	WASHER, LOCK	6

REF	PART #	DESCRIPTION	QTY.
26	140352	SCREW, M12X1.75X25	6
27	140564	BOLT, SHOULDER 3/8X3/4	4
28	140036	WASHER, FLAT	6
29	603044	PLATE, ACTUATOR LIFT	1
30	140027	WASHER, FLAT	2
31	140546	NUT, NYLOCK	2
32	612781	LIFT BRACKET, EXTRACTOR	1
33	602977	BRACKET, MOUNT CARPET TOOL	1
34	602565	SPRING, CARPET TOOL	1
35	140221	SCREW, 5/16-18X1 1/4	2
36	140220	SCREW, 5/16-18X2 1/2	2
37	140015	WASHER, LOCK	4
38	600306	TOOL, CARPET 22"	1
39	603046	BRACKET, BASE LEVELER	1
40	160613	●HOSE, VAC 1.5X30" W/CUFFS	1
41	600307	BRACKET, MOUNT EXTRACTOR	1
42	140226	SCREW, 5/16-18X5/8	4
43	140139	SLEEVE	2
44	140272	SCREW, M6X1.0X16MM	4
45	603093	BRACKET, BUMPER WHEEL	1
46	630477	WHEEL, 2" GRAY	8
47	140515	NUT, NYLOCK	4
48	140314	CLAMP, INSULATED 3/4 ID	2
49	36758	BOLT, SHOULDER	2
50	140046	WASHER, 1.00X.392X.090	2

● RECOMMENDED STOCK ITEMS

PARTS LIST

BRUSH BASE GROUP

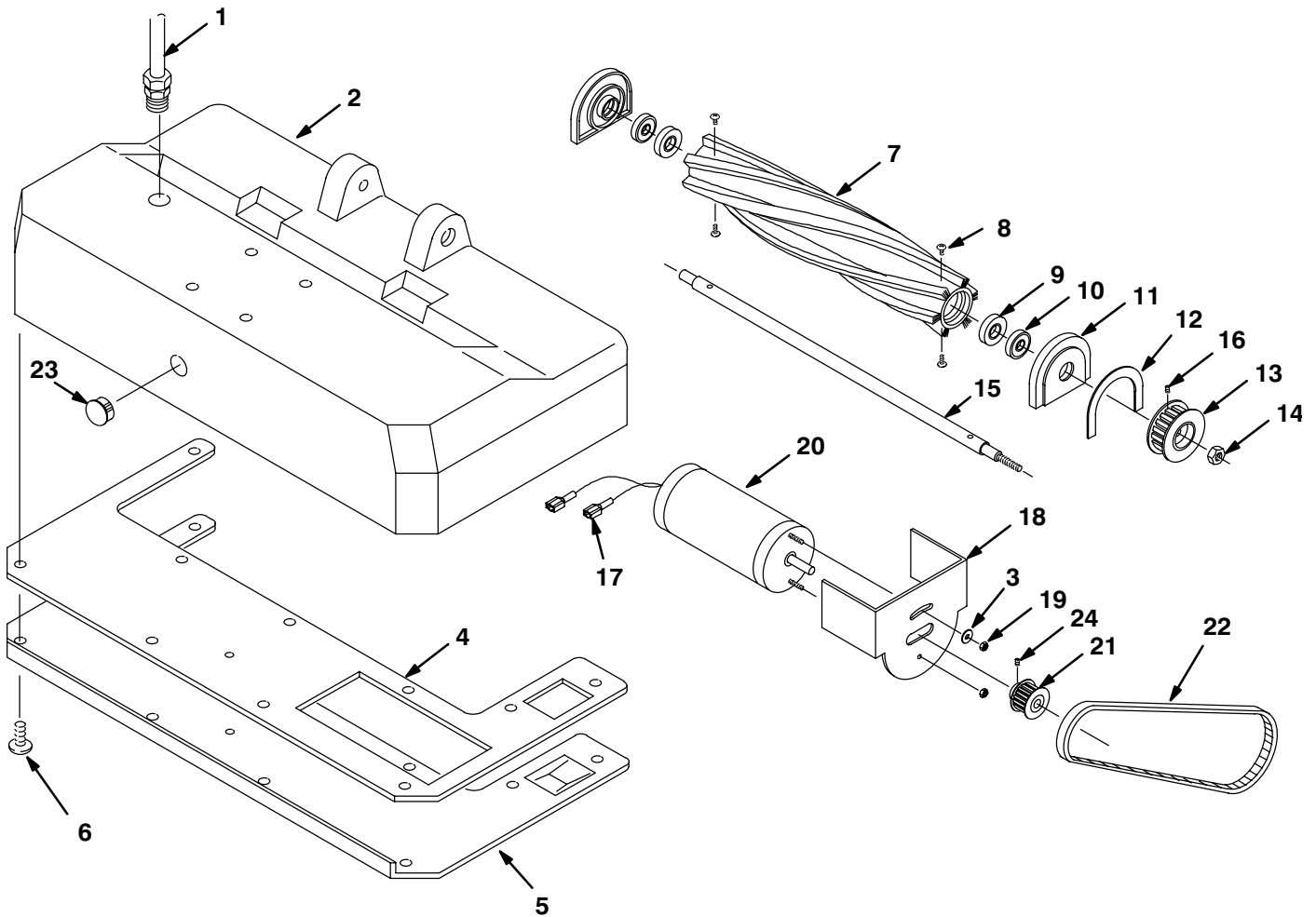

REF	PART #	DESCRIPTION	QTY.	
1	603193	CORD, 16/2X33 SJT	1	
2	101106	BASE, 22"	1	
3	200315016	WASHER, FLAT	1	
4	100157	GASKET, BASE PLATE	1	
5	230401.BK	PLATE, BASE	1	
6	140197	SCREW, 10-24X3/8 TRSPHL	11	
▽	700422	●ASM., BRUSH	1	
▲	7	240063	BRUSH, CYLINDER	1
▲	8	140554	SCREW, 1/4-20X3/4	4
▲	9	100049	SEAL, BRUSH BEARING	2
▲	10	140125	BEARING, BRUSH	2
▲	11	230261	BLOCK, BEARING	2
▲	12	100005	GASKET, BEARING BLOCK	1

REF	PART #	DESCRIPTION	QTY.	
▲	13	230408	PULLEY, BRUSH	1
▲	14	140548	NUT 5/16	1
▲	15	230406	SHAFT, BRUSH 22"	1
▲	16	140859	SCREW, SET 1/4-20X1/4	1
17	130096	TERMINAL, MALE DSCNT 16-14	2	
18	230411	BRACKET, BRUSH MOTOR	1	
19	140518	NUT, KEP 10-32	2	
20	575254000	●MOTOR, BRUSH .25HP 120V	1	
21	230410	●PULLEY, MOTOR	1	
22	230409	●BELT, TIMING	1	
23	130154	DOME PLUG	1	
24	140859	SCREW, SET 1/4-20X1/4	1	

▽ ASSEMBLY

▲ INCLUDED IN ASSEMBLY

● RECOMMENDED STOCK ITEMS

DRIVE GROUP

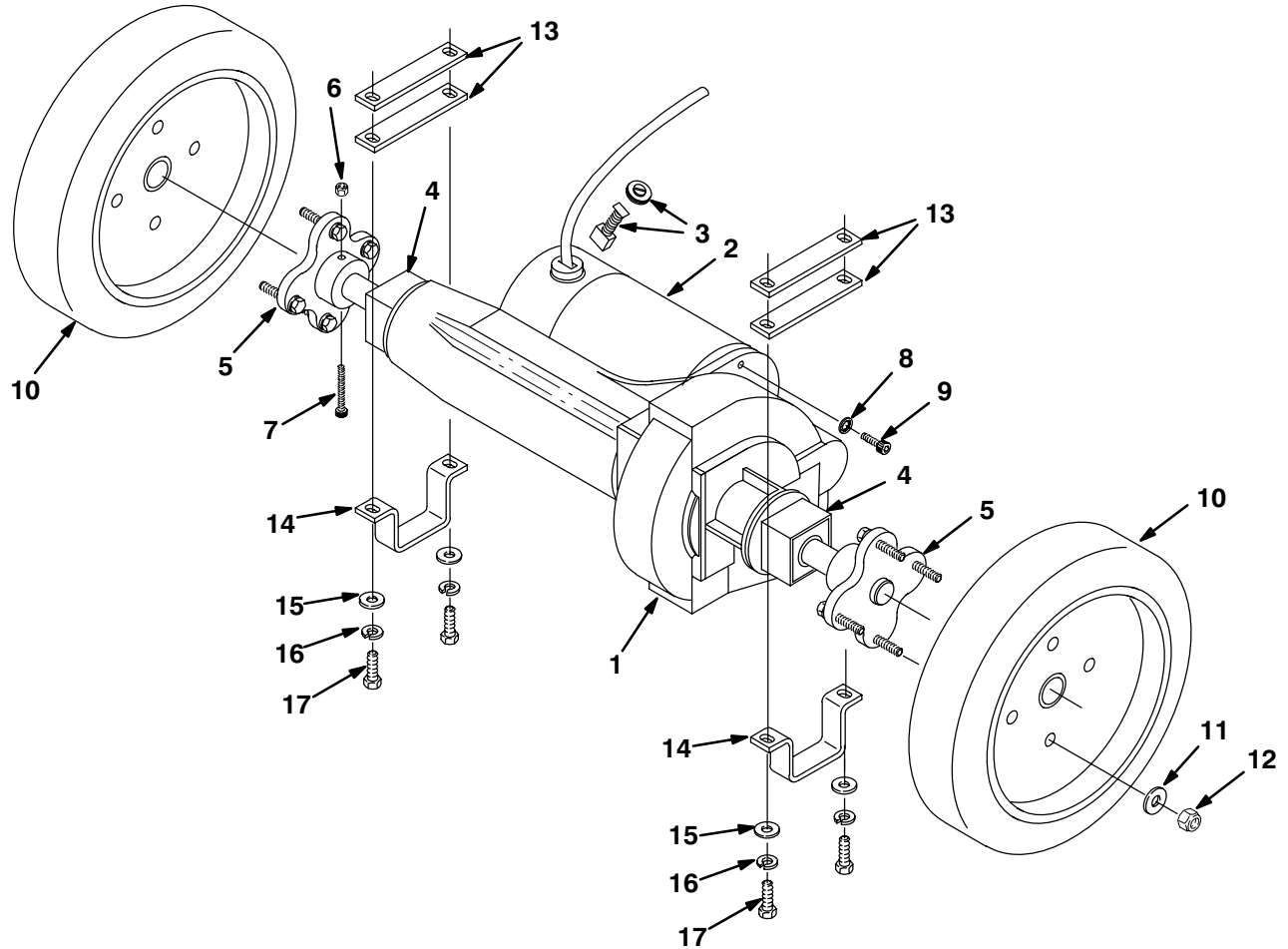

REF	PART #	DESCRIPTION	QTY.
▽ 1	612843	TRANSAXLE, 120V 72RPM	1
▲	612873	BODY, TRANSAXLE ONLY	1
▲	612874	COUPLING, NYLON TRANSAXLE	1
▲	612875	KEY, TRANSAXLE	1
▲ 2	612876	MOTOR, TRANSAXLE	1
▲ 3	612881	●BRUSH, CARBON KIT (BRUSHES W/CAPS-2/PK)	2
▲ 4	612880	SLEEVE, TRANSAXLE	2
▲ 5	612879	HUB, WHEEL TRANSAXLE	2
▲ 6	140552	NUT, 10-24 NYLOCK	2
▲ 7	31249	BOLT, SHOULDER .25X1.25	2

REF	PART #	DESCRIPTION	QTY.
▲ 8	32982	WASHER, INT. LOCK	2
▲ 9	01681	SCREW, SCKT .25-20X.75	2
10	607452	WHEEL, 8"	2
11	140000	WASHER, FLAT	8
12	140501	NUT, 1/4-20 NYLOCK	8
13	612783	SPACER, AXLE	4
14	612784	BRACKET, TRANSAXLE MTG	2
15	140028	WASHER, 3/8 FLAT	4
16	140333	WASHER, LOCK M10	4
17	612255000	SCREW, M10X35MM	4

▽ ASSEMBLY

▲ INCLUDED IN ASSEMBLY

● RECOMMENDED STOCK ITEMS

PARTS LIST

PLUMBING GROUP

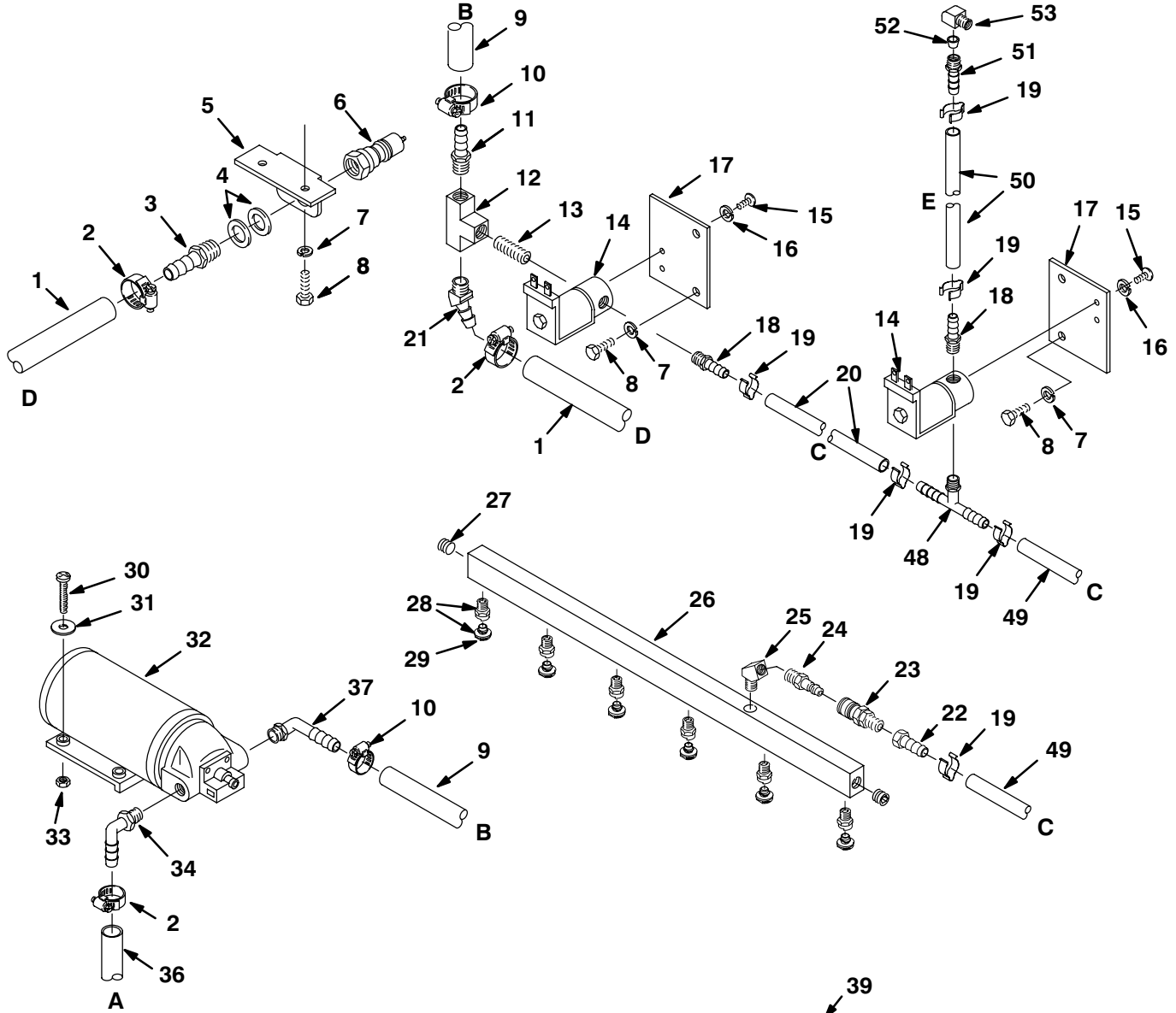

PUMP BREAKDOWN

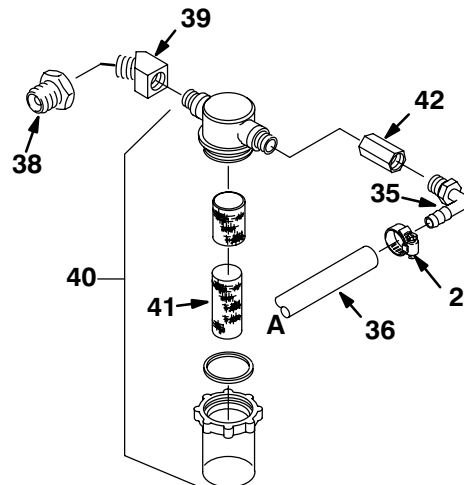
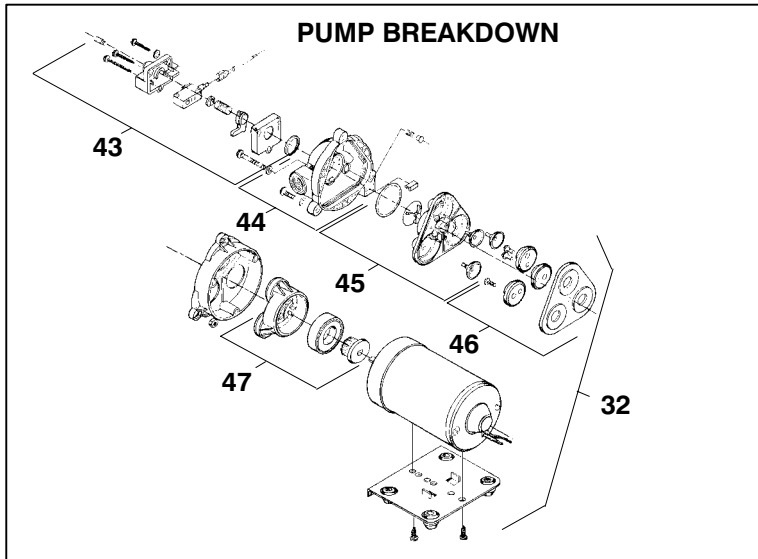

PLUMBING GROUP

REF	PART #	DESCRIPTION	QTY.
1	607704	HOSE, 3/8 X 24.5"	1
2	140310	CLAMP, HOSE	4
3	150516	FITTING, 1/4MX3/8H HOSE BARB	1
4	140058	WASHER, WAND	2
5	603063	BRACKET, QC MOUNT	1
6	150933	FITTING, 1/4F PLUG	1
7	140016	WASHER, LOCK 1/4	8
8	578187000	SCREW, M6X12MM	6
9	607705	HOSE, 1/2" X 24" RED	1
10	630369	CLAMP, HOSE	2
11	150517	FITTING, 1/4MX1/2H HOSE BARB	1
12	150706	TEE, 1/4F	1
13	150615	FITTING, 1/4M CLOSE NIPPLE	1
14	210033	●SOLENOID, WATER 120V	2
15	140801	SCREW, 8-32X3/8	4
16	140023	WASHER, LOCK #8	4
17	603055	BRACKET, SOLENOID	2
18	150515	FITTING, 1/4MX3/8H HOSE BARB	3
19	140325	CLAMP, 1/2	6
20	607706	HOSE, 1/4" X 18"	1
21	28303	FITTING, 1/4MX3/8H HOSE BARB	1
22	150520	FITTING, 1/8FX1/4H HOSE BARB	1
23	150915	FITTING, 1/8M COUPLER	1
∇	700423	ASM., SPRAY BAR	1
▲ 24	150921	FITTING, 1/8M PLUG	1
▲ 25	150422	FITTING, 1/8MX1/8F 45° ELBOW	1
▲ 26	230407	MANIFOLD, SPRAYBAR	1
▲ 27	150208	PLUG	2
▲ 28	201011	●FITTING, TWISTOUT NOZZLE (80015)	6

REF	PART #	DESCRIPTION	QTY.
29	201013	●FITTING, TIP RPLMNT (80015)	6
30	140899	SCREW, 10-24X1 1/4	2
31	140012	WASHER, FLAT	2
32	180103	●PUMP, 100 PSI 120V	1
	130096	TERMINAL, 120V	1
33	140552	NUT, NYLOCK 10-24	2
34	150412	FITTING, 3/8MX3/8H ELBOW 90°	1
35	150415	FITTING, 1/4MX3/8H ELBOW 90°	1
36	607305	TUBING, 3/8 X 30" GRAY VINYL	1
37	150425	FITTING, 3/8MX1/2H 90° ELBOW	1
38	150101	FITTING, 1/2MX1/4F BUSHING	1
39	150403	FITTING, 1/4MX1/4FX45° ELBOW	1
40	180619	FILTER, 1/4 NPT CLEAR BOWL	1
41	180638	●SLEEVE, NYLON FILTER	1
42	150302	FITTING, 1/4FX1/4F COUPLING	1
43	190129	●KIT, PUMP PRESSURE SWITCH	1
	190172	●KIT, PUMP PRES SWITCH (VITON)	1
	190134	●KIT, PUMP DIAPHRAGM ONLY	1
44	190128	●KIT, PUMP UPPER HOUSING	1
	190124	●KIT, PUMP CHECK VALVE ONLY	1
45	190171	●KIT, PUMP VALVE (VITON)	1
46	190131	●KIT, PUMP SERVICE	1
47	190130	●KIT, PUMP LOWER HOUSING	1
48	607306	FITTING, 1/4MX1/4HX1/4H TEE	1
49	607307	HOSE, 1/4" X 12" LP GRAY	1
50	607707	HOSE, 1/4" X 9.5" LP GRAY	1
51	603649	FITTING, 1/4MX1/4H-1/8NPTF	1
52	603557	FITTING, PLUG W/ 1/16" ORIFICE	1
53	150406	FITTING, 1/4MX1/4F ELB STRT90	1

∇ ASSEMBLY

▲ INCLUDED IN ASSEMBLY

● RECOMMENDED STOCK ITEMS

PARTS LIST

CONSOLE GROUP

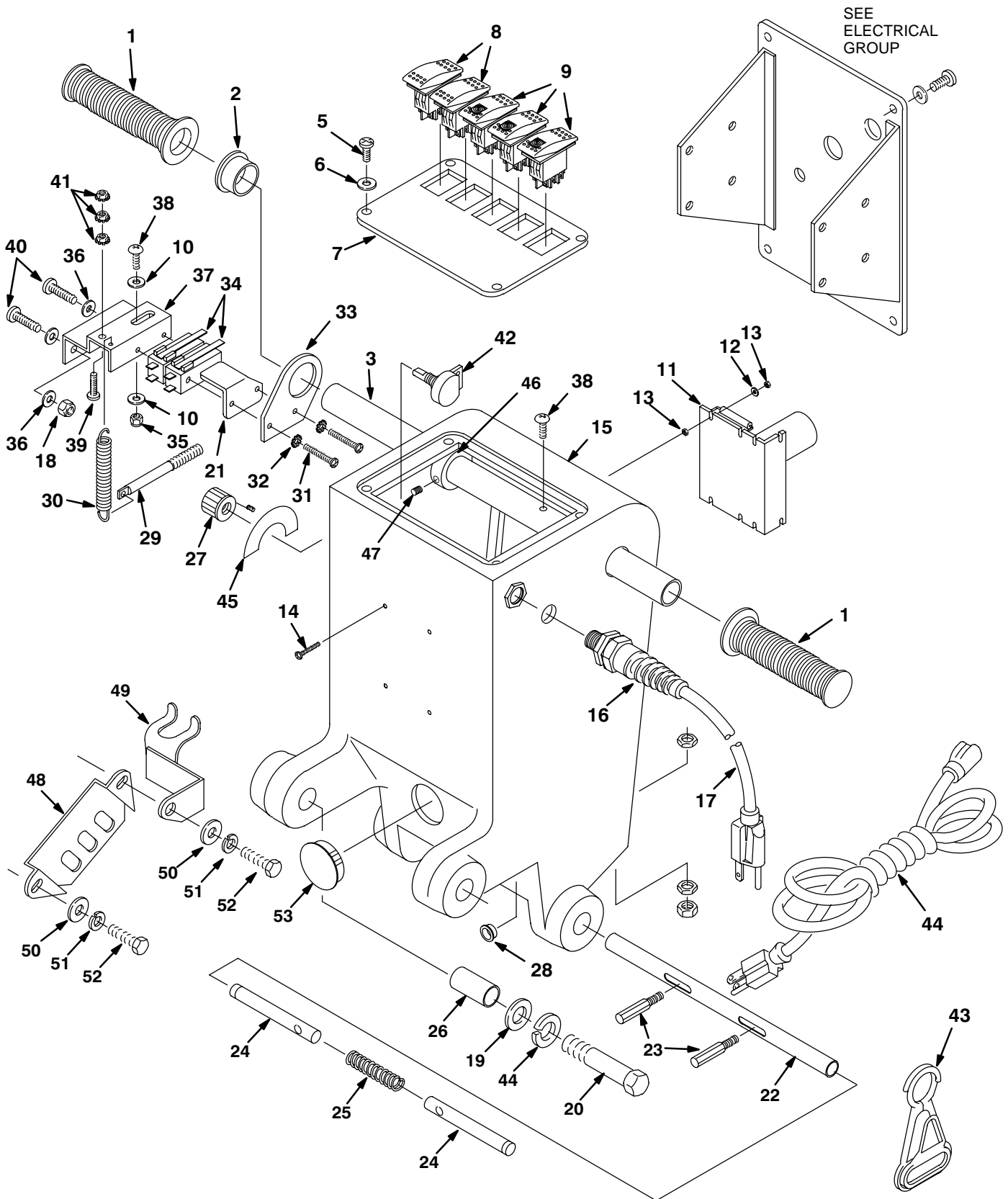

CONSOLE GROUP

REF	PART #	DESCRIPTION	QTY.
1	200823	GRIP, HANDLE TUBE	2
2	605351	BUSHING	1
3	604402	HANDLE, TUBE	1
4	140024	WASHER, #10 INT	2
5	578141000	SCREW, M5X10MM	4
6	140018	WASHER, LOCK #10	4
▽	607699	ASM., SWITCH PANEL	1
▲ 7	604325	PANEL, SWITCH	1
▲	612786	HARNESS, WIRE MAIN	1
▲ 8	602919	●SWITCH, DPDT ON/OFF	2
▲ 9	604326	●SWITCH, LIGHTED ROCKER 120V	3
10	140012	WASHER, 3/16 FLAT	2
11	612857	●CONTROL, BOARD 120V	1
12	140026	WASHER, #6 FLAT	4
13	140534	NUT, 6-32 NYLON	8
14	140879	SCREW, 6-32X3/4 RNDSLT	4
15	607556	HOUSING, CONTROL, TEAL	1
16	130167	CORDGRIP, LIQTIGHT FLX 1/2N	1
17	130228	CORD, 14/3 X 34" YLW SMOOTH	1
18	140284	NUT, M6X1.0	2
19	140045	WASHER, FLAT 1/2	2
20	140351	SCREW, M12X70MM	2
21	603830	PLATE, GUARD SWITCH	1
22	230715	TUBE, HANDLE ADJUSTMENT	1
23	230649	PIN, HANDLE ADJUSTMENT	2
24	230710	PIN, HANDLE LOCK	2
25	140415	SPRING, LOCK PIN	1
26	140155	BUSHING	2

REF	PART #	DESCRIPTION	QTY.
27	606550	KNOB, SPEED CONTROL	1
28	603007	BUSHING, SNAP	1
29	602886	PIN, SPRING RETURN	1
30	605812	SPRING, EXPANSION	1
31	140830	SCREW, 6-32X1-5/8	2
32	140019	WASHER, LOCK #6	2
33	27098	BRACKET, SWITCH	1
34	130729	●SWITCH, ROLL-THROTTLE	2
35	140552	NUT, 10-24	1
36	140000	WASHER, FLAT 1/4	4
37	25671	MOUNT, SWITCH	1
38	140890	SCREW, 10-24X1/2	2
39	140900	SCREW, 10-24X3/4	1
40	608322	SCREW, M6X1.0X16MM	2
41	140519	NUT, 10-24 KEP	3
42	190802	●POTENTIOMETER, 50K	1
43	130176	BELT CLIP, STRAIN RELIEF	1
44	130229	CORD, 14/3X75'	1
45	606549	DECAL, SPEED CONTROL	1
46	605094	COLLAR, HANDLE	2
47	140859	SCREW, 1/4 SK	2
48	230661	PLATE, LOCK CONTROL HOUSING	2
49	611979	WELDMENT, DRAIN HOSE	1
50	140027	WASHER, FLAT	4
51	140015	WASHER, LOCK	4
52	200031488	SCREW, M8X1.25X20MM	4
53	601401	PLUG, DOME 1.5" DIA BLK	1

▽ ASSEMBLY

▲ INCLUDED IN ASSEMBLY

● RECOMMENDED STOCK ITEMS

PARTS LIST

ELECTRICAL GROUP

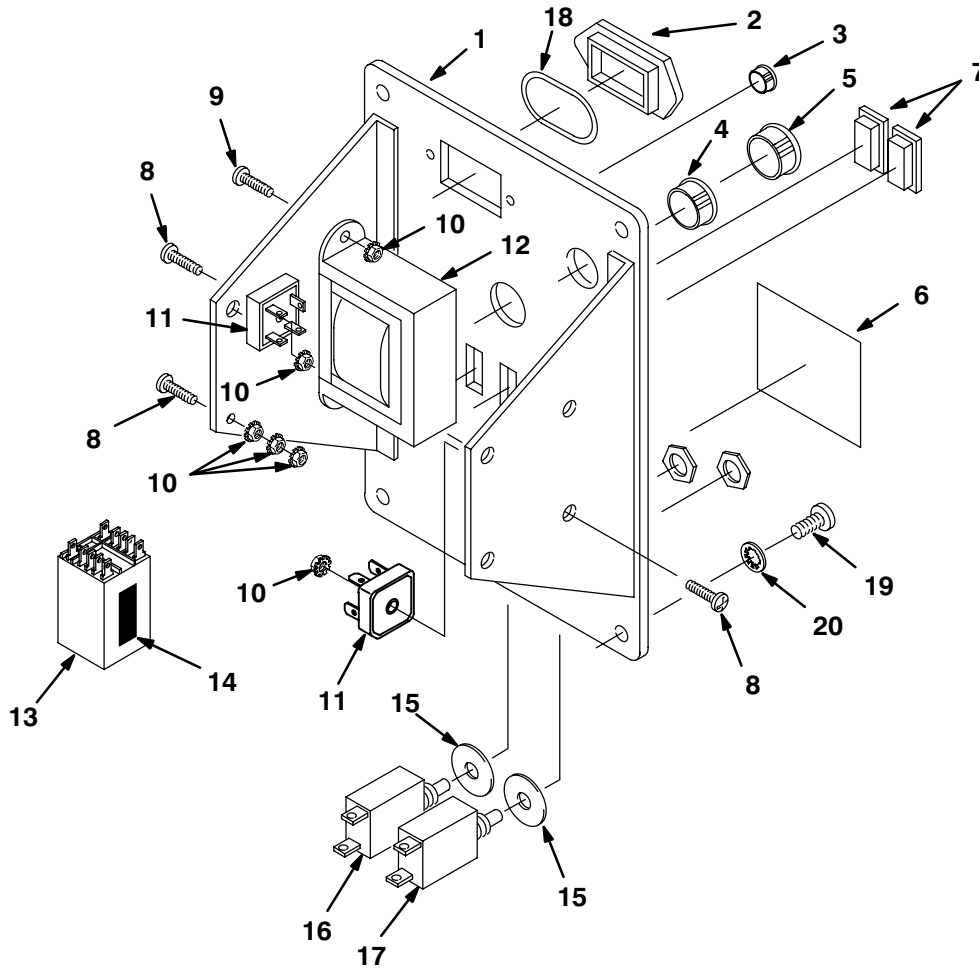

REF	PART #	DESCRIPTION	QTY.
1	602559	PANEL, CONTROL HOUSING	1
2	609969	PLUG, HOUR METER	1
3	069764626	PLUG, HOLE 012.7	1
4	130161	PLUG, DOME .875	1
5	130175	PLUG, DOME .750	1
6	630420	DECAL, FLAMMABLE MATERIAL	1
7	582150	PLUG, ACCESSORY SWITCH	2
8	140900	SCREW, 10-24X3/4	3
9	140890	SCREW, 10-24X1/2	2
10	140519	NUT, 10-24 KEP	7

REF	PART #	DESCRIPTION	QTY.
11	130304	●RECTIFIER BRIDGE 600V 15AMP	2
12	604330	●TRANSFORMER 120V	1
13	604327	●SOLENOID, 120V	1
14	606243	TAPE, ACRYLIC FOAM 1" WIDE	1
15	140028	WASHER, FLAT 3/8	2
16	582510	●BREAKER, CIRCUIT 4.5A	1
17	609080	●BREAKER, CIRCUIT 2.0A	1
18	605823	O-RING	1
19	578141000	SCREW, M5X10	4
20	140018	WASHER, LOCK #10	4

▽ ASSEMBLY

▲ INCLUDED IN ASSEMBLY

● RECOMMENDED STOCK ITEMS

SOLUTION AND VACUUM HOSES

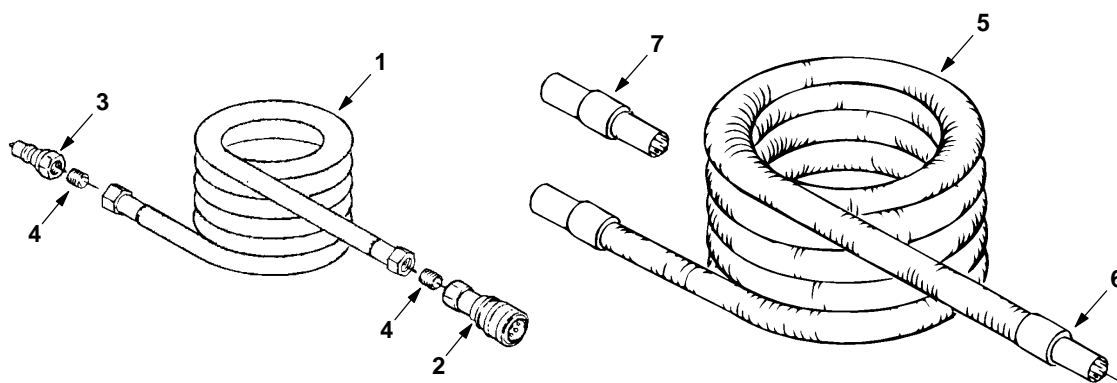

REF	PART #	DESCRIPTION	QTY.
▽	600329	●KIT, HOSE, VAC & SOL 4.6M (15')	1
	600330	●KIT, HOSE, VAC & SOL 7.6M (25')	1
	600331	●KIT, HOSE, VAC & SOL 15.2M (50')	1
▲▽ 1	160185	HOSE, SOLUTION 4.6M (15')	1
	160186	HOSE, SOLUTION 7.6M (25')	1
	160187	HOSE, SOLUTION 15.2M (50')	1
▲ 2	150913	●COUPLER, QUICK SER. 60	1
▲ 3	150933	PLUG, QUICK COUPLER	1
▲ 4	150615	NIPPLE	2

REF	PART #	DESCRIPTION	QTY.
▲▽ 5	160400	HOSE, VACUUM 4.6M (15')	1
	160401	HOSE, VACUUM 7.6M (25')	1
	160402	HOSE, VACUUM 15.2M (50')	1
▲ 6	160430	●CUFF, HOSE 1-1/2"	2
7	160451	●CONNECTOR, VAC HOSE 1-1/2"	1

▽ ASSEMBLY

▲ INCLUDED IN ASSEMBLY

● RECOMMENDED STOCK ITEMS

127 mm (5 in) HAND TOOL

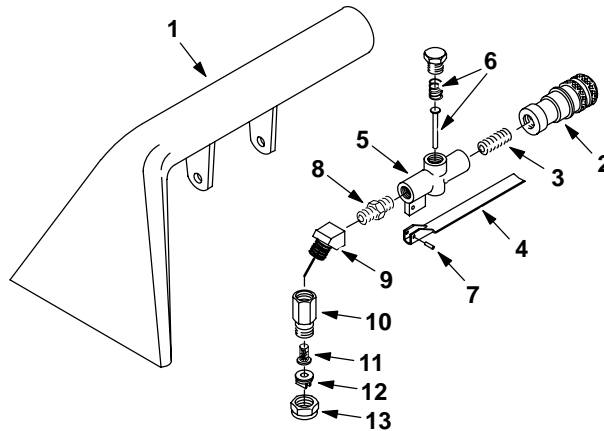

REF	PART #	DESCRIPTION	QTY.
▽	200505	●ASM., HAND TOOL 5"	1
▲ 1	200431.BK	TOOL, HAND	1
▲ 2	150913	FITTING, 1/4F QD FML COUPLER	1
▲ 3	150615	NIPPLE, CLOSE	1
▲ 4	200905	TRIGGER, HAND TOOL	1
▲ 5	210210	●VALVE, FLOW CONTROL	1
▲ 6	190600	VALVE PIN & SPRING	1

REF	PART #	DESCRIPTION	QTY.
▲ 7	140609	PIN, ROLL 3/16	1
▲ 8	150606	NIPPLE, HEX 1/4	1
▲ 9	150403	ELBOW, ST 1/4 45°	1
▲ 10	200992	BODY, SPRAY 1/4F	1
▲ 11	200996	SCREEN, SPRAY NOZZLE	1
▲ 12	200965	●TIP, SPRAY #8002	1
▲ 13	200994	CAP, SPRAY BODY	1

▽ ASSEMBLY

▲ INCLUDED IN ASSEMBLY

● RECOMMENDED STOCK ITEMS

76 mm (3 in) CREVICE TOOL

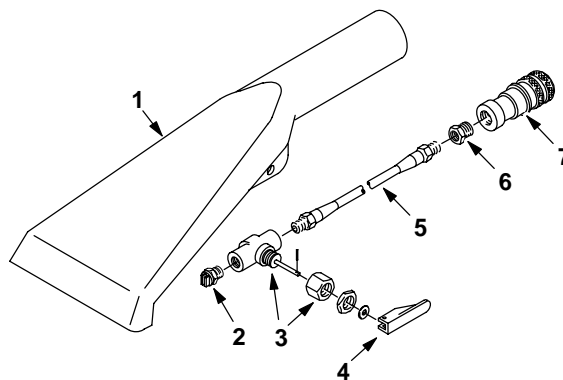

REF	PART #	DESCRIPTION	QTY.
▽	200517	●ASM., CREVICE TOOL SER.60	1
▲ 1	200436.BK	TOOL, CREVICE BLACK	1
▲ 2	200975	●FITTING, TIP #5002 V-JET	1
▲ 3	210014	●VALVE, TOGGLE W/NUT	1

REF	PART #	DESCRIPTION	QTY.
▲ 4	210020	POSITIONER, VALVE HANDLE	1
▲ 5	160106	HOSE, SOLUTION	1
▲ 6	150100	FITTING, 1/4MX1/8F BUSHING	1
▲ 7	150913	FITTING, 1/4F QD FML COUPLER	1

▽ ASSEMBLY

▲ INCLUDED IN ASSEMBLY

● RECOMMENDED STOCK ITEMS

LOW PRESSURE UPHOLSTERY TOOL

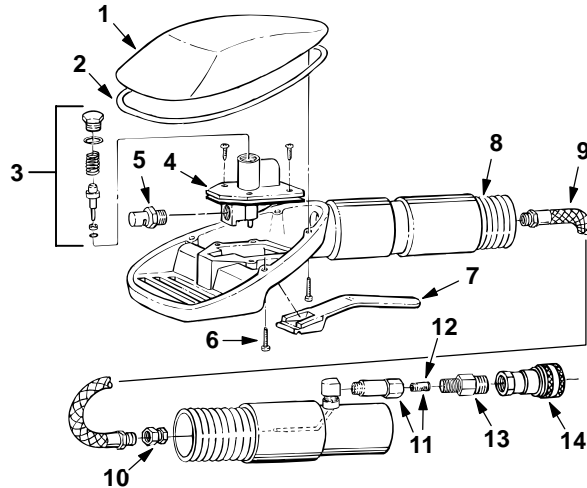

REF	PART #	DESCRIPTION	QTY.
▽	200540	●ASSEMBLY, UPHOLSTERY TOOL	1
▲ 1	200845	COVER	1
▲ 2	200843	GASKET	1
▲ 3	190631	●KIT, VALVE ASM.	1
▲ 4	210226	●VALVE, LP	1
▲ 5	200991	●NOZZLE	1
▲ 6	200838	SCREW	4
▲ 7	200840	TRIGGER	1

REF	PART #	DESCRIPTION	QTY.
▲ 8	200844	●HOSE, VACUUM	1
▲ 9	200837	●HOSE, SOLUTION	1
▲ 10	200848	FITTING	1
▲ 11	200842	FILTER	1
▲ 12	200841	SCREEN, FILTER	1
▲ 13	150606	FITTING, 1/4MX1/4M	1
▲ 14	150913	●COUPLER	1

▽ ASSEMBLY

▲ INCLUDED IN ASSEMBLY

● RECOMMENDED STOCK ITEMS

330mm (13 in) LOW PRESSURE FLOOR TOOL

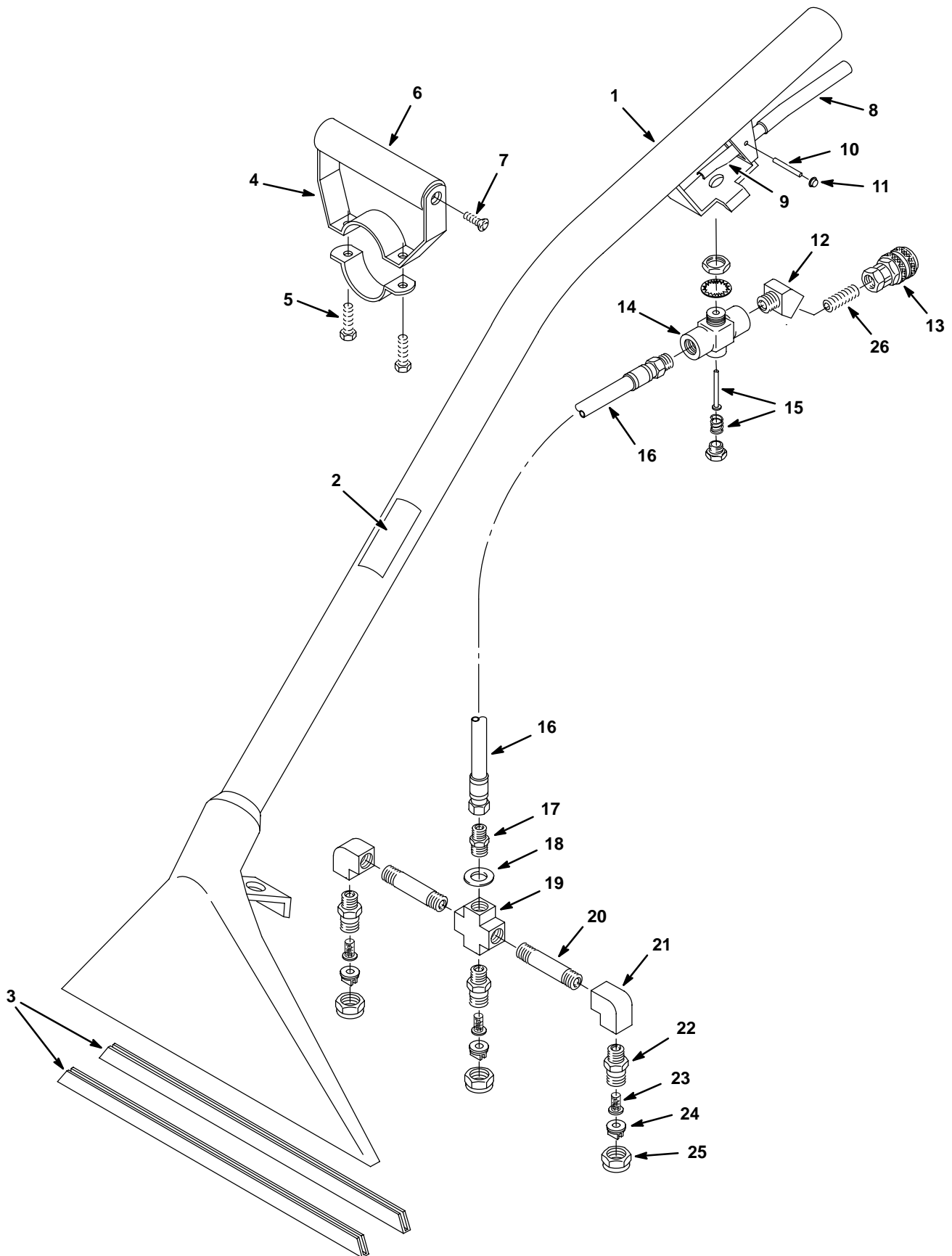

330mm (13 in) LOW PRESSURE FLOOR TOOL

REF	PART #	DESCRIPTION	QTY.
▽	600048	●ASM., WAND LOW PRESSURE	1
▲ 1	200403.BK	TOOL, FLOOR BLACK	1
▲ 2	120846	DECAL, LOW PRESSURE TOOL	1
▲ 3	200939	●SHOE, 330MM (13 IN) FLR TOOL	2
▲▽ 4	200927	GRIP, HAND ADJ. COMPLETE	1
▲ 5	140259	SCREW, 1/4-20X5/8	2
▲ 6	200912	GRIP, HANDLE FOAM	1
▲ 7	140834	SCREW, 1/4-20X5/8	2
▲ 8	200809	SLEEVE, HANDLE	1
▲ 9	200902	HANDLE, VALVE	1
▲ 10	140605	PIN, HANDLE	1
▲ 11	140520	NUT, 1/4 PUSH BLK	2
▲ 12	150403	FITTING, 1/4MX1/4F 45 STR	1
▲ 13	150913	●FITTING, 1/4F QD CPLR SER 60	1

REF	PART #	DESCRIPTION	QTY.
▲▽ 14	210150	●VALVE, FLOW CONTROL	1
▲ 15	190603	●KIT, VALVE PIN AND SPRING	1
▲ 16	160170	ASM, HOSE LOW PRESSURE	1
▲ 17	150606	FITTING, 1/4MX1-3/8HEXNIP	1
▲ 18	140058	WASHER, .543X.875X.062 WAND	1
▲▽	700062	ASM., SPRAYBAR WO/TIPS	1
▲ 19	150700	CROSS, 1/4 FPT	1
▲ 20	150600	FITTING, 1/4MX2" NIPPLE	2
▲ 21	150401	FITTING, 1/4FX1/4F ELBOW 90	2
▲ 22	200993	SPRAY BODY, 1/4" MALE	3
▲ 23	200996	●FILTER, SCREEN 100 MESH	3
▲ 24	200964	●FITTING, TIP 11003 T-JET	3
▲ 25	200994	●CAP, SPRAY BODY	3
▲ 26	150615	FITTING, 1/4MX7/8 CLSNIP	1

▽ ASSEMBLY

▲ INCLUDED IN ASSEMBLY

● RECOMMENDED STOCK ITEMS

406mm (16 in) LOW PRESSURE FLOOR TOOL

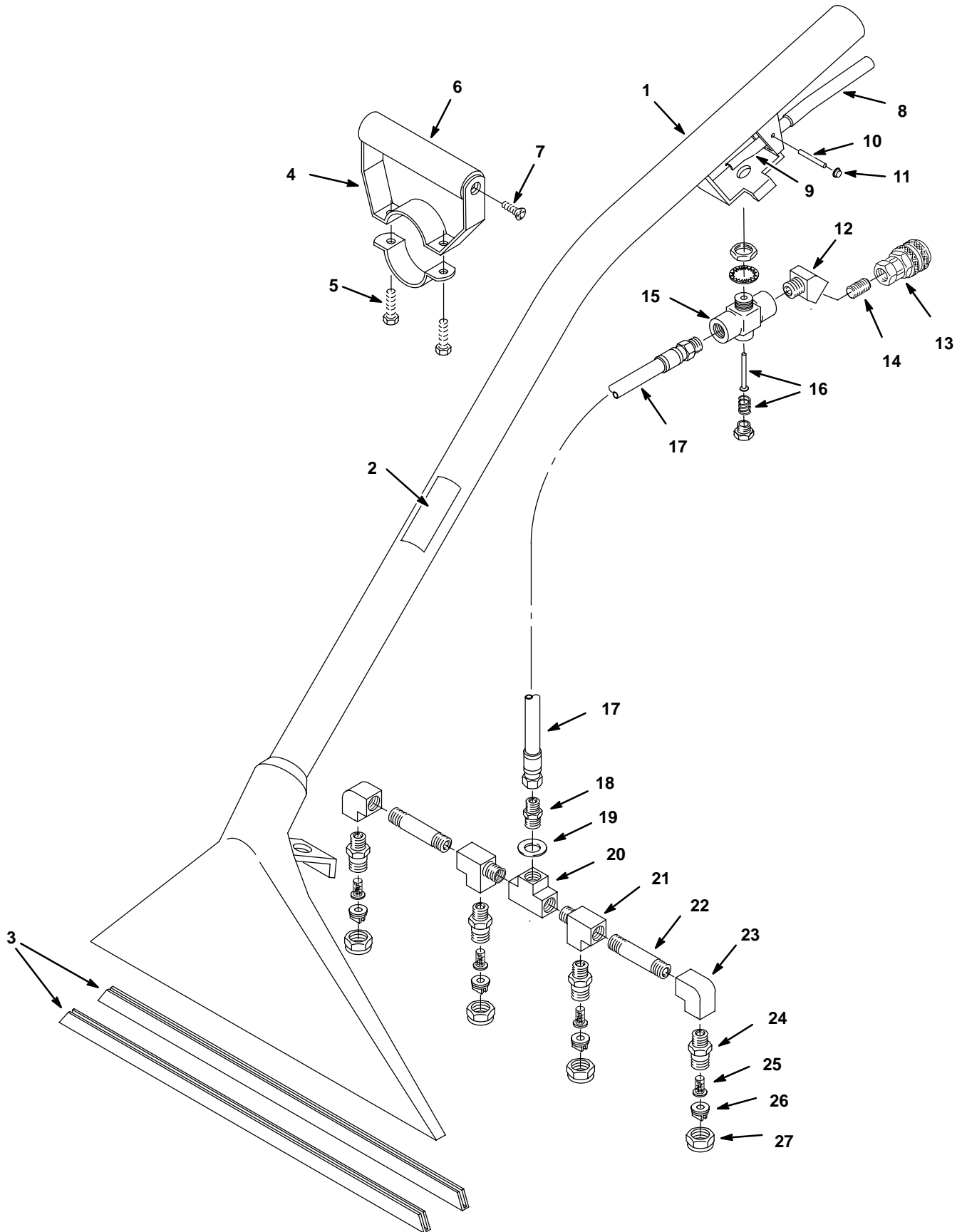

406mm (16 in) LOW PRESSURE FLOOR TOOL

REF	PART #	DESCRIPTION	QTY.
▽	200503	●ASM., FLOOR TOOL	1
▲ 1	200411.BK	TOOL, FLOOR 406MM (16 IN)	1
▲ 2	120846	DECAL, LOW PRESSURE TOOL	1
▲ 3	200956	●SHOE, 406MM (16 IN) FLR TOOL	2
▲▽ 4	200927	GRIP, HAND ADJ. COMPLETE	1
▲ 5	140259	SCREW, 1/4-20X5/8	2
▲ 6	200912	GRIP, HANDLE FOAM	1
▲ 7	140834	SCREW, 1/4-20X5/8	2
▲ 8	200809	SLEEVE, HANDLE	1
▲ 9	200902	HANDLE, VALVE	1
▲ 10	140605	PIN, HANDLE	1
▲ 11	140520	NUT, 1/4 PUSH BLK	2
▲ 12	150403	FITTING, 1/4MX1/4F 45 STR	1
▲ 13	150913	●COUPLER, SER. 60	1
▲ 14	150615	NIPPLE, CLOSE 1/4	1

REF	PART #	DESCRIPTION	QTY.
▲▽ 15	210150	●VALVE, FLOW CONTROL	1
▲ 16	190603	●KIT, VALVE PIN AND SPRING	1
▲ 17	160170	ASM, HOSE LOW PRESSURE	1
▲ 18	150606	FITTING, 1/4MX1-3/8HEXNIP	1
▲ 19	140058	WASHER, .543X.875X.062 WAND	1
▲▽	700656	ASM., SPRAYBAR 16" WO/TIPS	1
▲ 20	150706	FITTING, 1/4F TEE	1
▲ 21	150709	FITTING, 1/4F X 1/4F X 1/4M	2
▲ 22	150600	FITTING, 1/4MX2" NIPPLE	2
▲ 23	150401	FITTING, 1/4FX1/4F ELBOW 90	2
▲ 24	200993	SPRAY BODY, 1/4" MALE	4
▲ 25	200996	●FILTER, SCREEN 100 MESH	4
▲ 26	200964	●FITTING, TIP 11003 T-JET	4
▲ 27	200994	●CAP, SPRAY BODY	4

▽ ASSEMBLY

▲ INCLUDED IN ASSEMBLY

● RECOMMENDED STOCK ITEMS