



Electronic Service Manuals

This electronic document is provided as a service to our customers. We do not create the contents of the information contained in this document. Should you have detailed questions pertaining to the information contained in this document, you may contact Michco, or the manufacturer which provided the original information in this electronic deliverable. Michco's only part in this electronic deliverable was the electronic assembly process. By providing this manual on line we are not guaranteeing parts availability.

You may contact Michco through the following methods:

Phone (517) 484-9312 or (800) 331-3339

2011 N. High St. -- Lansing, Michigan -- 48906

Fax: (517) 484-9836

Email: CustServe@Michco.com

Web site: www.Michco.Com

Parts Web site: www.FloorMachineParts.Com

Order Parts on Line at:

www.FloorMachineParts.Com

Directly to Parts & Service:

By Email: **Shop@Michco.com**

By Fax: (517) 702-2041

By Voice: Use numbers above.

Serving the Cleaning Industry Since 1922

Notice: All copyrighted material remains property of original owners, all trademarks are property of respective owners. Manuals are subject to Manufacturer's reproduction limitations. Originals or reproductions were provided by manufacturers through a request. We make no warranty as to the correctness of information provided in this document and you assume all risk. By placing these manuals on line we are not declaring our corporation to be an manufacturer authorized dealer or provider, please check our web site for authorized manufacturers we represent.



1465
1480
1490

(Parts Manual)

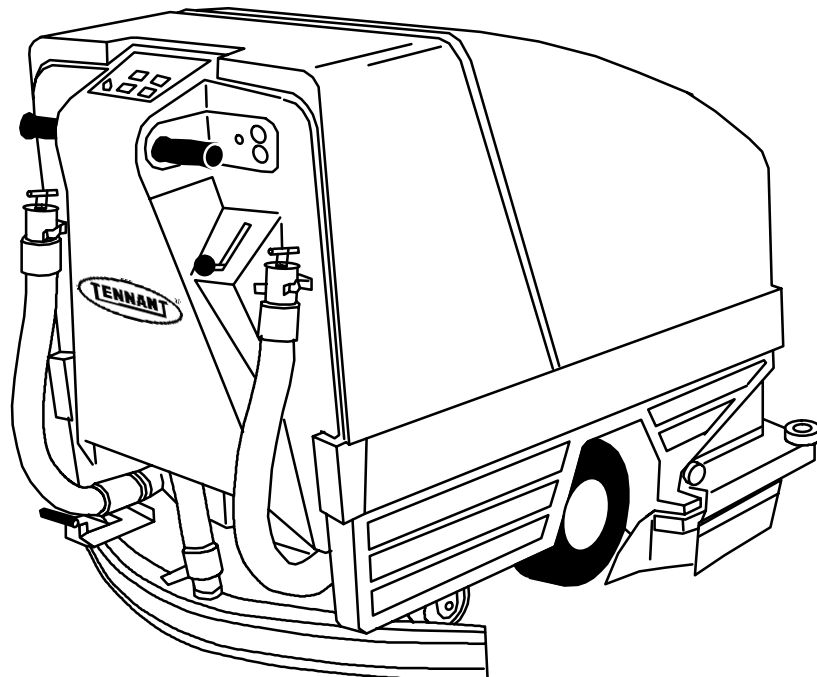

MM185
Rev. 11 (9-94)



This manual is furnished with each new TENNANT Model 1465, 1480, and 1490. It provides necessary operating and preventive maintenance instructions. Read this manual completely and understand the machine before operating or servicing it.

This manual covers all machine variations and standard options. The instruction portion of the manual consists of the Specification, Operation, Maintenance, and Appendix sections. The parts portion consists of How to use this Manual; 1465 Parts; 1480 Parts; 1490 Parts; Options; Breakdowns; and Cross Reference sections.

All right side and left side references to the machine are determined by facing the direction of forward travel. All hardware considered to be of a common nature or locally available has been omitted from the parts sections. Be aware that this machine may contain metric hardware. Make sure you use equivalent hardware when replacement becomes necessary.

This machine will provide excellent service. However, the best results will be obtained at minimum costs if:

- The machine is operated with reasonable care.
- The machine is maintained regularly – per the maintenance instructions provided.
- The machine is maintained with TENNANT supplied or equivalent parts.

Parts and supplies may be ordered by phone or mail from any TENNANT parts and service center, distributor, or from any of the TENNANT subsidiaries. Before ordering parts or supplies, be sure to have your machine model number and serial number handy. Fill out the data block below for future reference. The telephone numbers, telex numbers, mailing addresses, and locations of those outlets are listed in the Customer Documents section of the manual.

MACHINE DATA <i>Please fill out at time of installation.</i>
Machine Serial Number – _____
Engine Serial Number – _____
Sales Representative – _____
Customer Number – _____
Date of Installation – _____
Manual Number – MM185
Revision: 11
Published: 9-94

Trademark Registered in: Austria, Benelux, Denmark, England, France, Germany, Italy, Spain, Switzerland, United States, Argentina, Australia, Canada, Japan, Mexico, Sweden, by TENNANT, Minneapolis, Minnesota, U.S.A.

Copyright 1988, 1989, 1990, 1991, 1992, 1993, 1994 TENNANT, Printed in U.S.A.

HOW TO USE THIS MANUAL

This section on *HOW TO USE THIS MANUAL* will tell you how to:

- Find important machine information for ordering correct repair parts.
- Find TENNANT part numbers.
- Order TENNANT parts and supplies.

IMPORTANT INFORMATION

When placing an order for parts, the machine model and machine serial number are important. Refer to the *MACHINE DATA* box which is filled out during the installation of your machine. The *MACHINE DATA* box is located on the inside of the front cover of this manual.

MACHINE DATA	
<i>Please fill out at time of installation.</i>	
Machine Serial Number -	_____
Engine Serial Number -	_____
Sales Representative -	_____
Customer Number -	_____
Date of Installation -	_____
Manual Number -	MM185
Revision:	10
Published:	9-93

The model number of your machine is on the side of the machine.

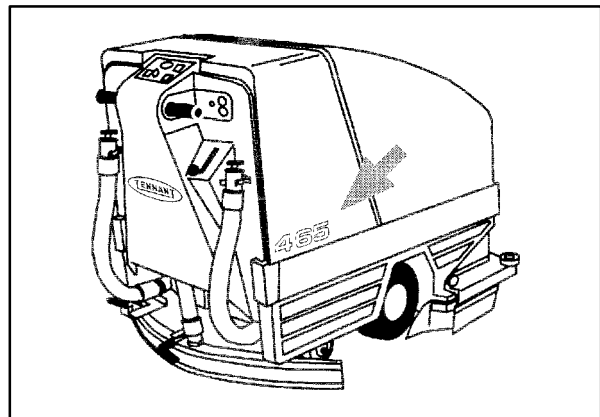

The serial number of your machine is printed on the machine data plate located as shown.

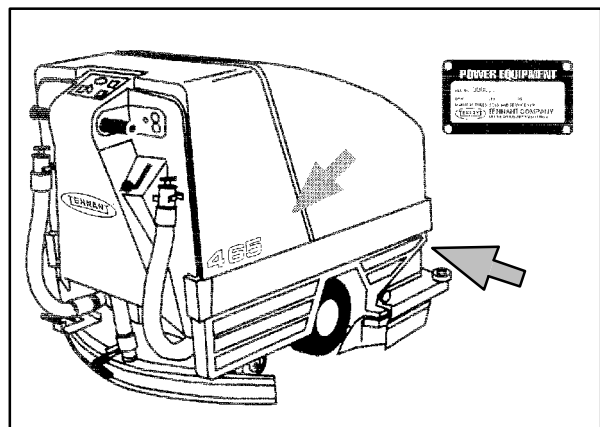

HOW TO USE THIS MANUAL

FINDING A TENNANT PART NUMBER

This manual contains the following sections:

- HOW TO USE THIS MANUAL
- STANDARD PARTS
- OPTIONS
- BREAKDOWNS
- CROSS REFERENCE

The STANDARD PARTS section lists repair parts for standard machines. They are grouped in this general order:

- General wear parts.
- Machine frame and related parts.
- Machine propelling system.
- Scrubbing components.
- Electrical parts.

The OPTION section lists repair parts of options.

The BREAKDOWN section lists available repair parts of major components.

All sections in this manual consist of parts illustrations and corresponding parts lists.

The parts illustrations are numbered with **Ref** numbers which refer to corresponding parts lists.

The parts lists include a number of columns of information:

- **Ref** - column refers to the reference number on the parts illustration.
 ▽ - indicates the part is an assembly.
 ▲ - indicates the part is included in the assembly listed just before it.
- **TENNANT Part No.** - column lists the TENNANT part number for the part.
- **Serial Number** - column indicates the set of machines the part number is applicable to. Serial numbers change when the machine design has been modified. The most current design of the machine is shown in the main illustration, older designs are boxed in a corner of the illustration.
- **Description** - column is a brief description of the part.
- **Qty.** - column lists the quantity of that part used in that area of the machine.

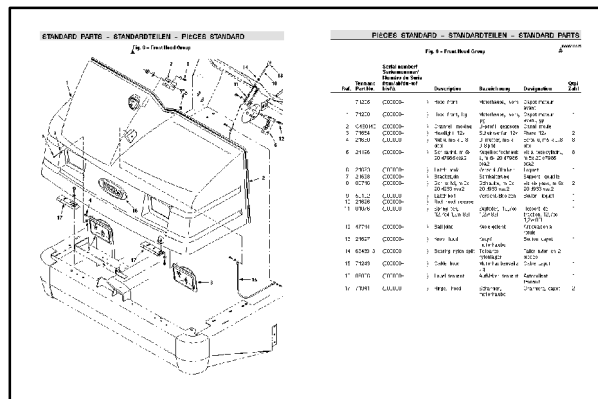

Ref.	Tennant Part No.	Serial number/ Serial numbers/ Numéro de Serie from/ab/du-to/ bis/à	Description	Bezeichnung	Designation	Qty/ Zahl
▽ 1	87365	(000000-)	Gearbox	Getriebe	Boîte de vitesses	1
▲ 2	87640	(000000-)	O-ring	O-ring	Joint torique	2
▲ 3	87641	(000000-)	Plug	Stopfen	Bouchon	2
▲ 4	87839	(000000-)	Fit-plate, 106.997	Schmier-nippel, 106.997	Graisseur, 106.997	2
▲ 5	87849	(000000-)	Driving gear	Getriebe	Mécanisme d'entraînement	1
▲ 6	12640	(000000-)	Bolt, wheel	Radbolzen	Boulon roue	6
▲ 7	61791	(000000-)	Bearing and housing	Lagergehäuse	Boîtier roulement	1
8	12646	(000000-)	Seal o-ring	O-ring-dichtung	Joint torique d'étanchéité	1
9	60198	(000000-)	Motor, traction 36v	Motor traction 36v	Motor traction 36v	1
10	02076	(000000-)	Cover, terminal ung	Batteriepolabdeck- ung	Cache-pôle batterie	4

NOTE: If a service kit is installed on your machine, be sure to keep the **INSTRUCTION BULLETIN** which came with the kit. It contains repair parts numbers needed for ordering future parts.

NOTE: Fasteners used in this machine may be metric or non-metric. Take care when replacing hardware to replace with same thread size.

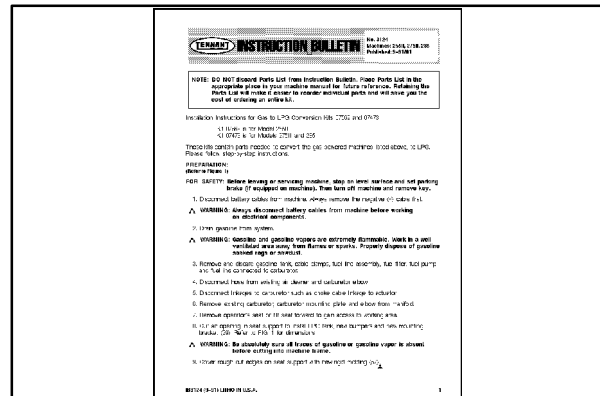

PLACING AN ORDER

Orders may be placed by phone, fax, or by mail. Phone orders may need written confirmation. Follow the steps below to insure prompt delivery:

1. Identify the model number of your machine.
2. Identify the serial number of your machine.
3. Find the part number of the part you need. Do not order by page number or reference number. If you are not able to find the part number, call your TENNANT representative for help or send the old part as a sample.
4. Determine the quantity of the part you need.
5. Provide the following company information:
 - Company name
 - Customer ID Number
 - Shipping address
 - Billing address
 - First and last name of person ordering parts
 - Telephone number
 - Purchase order number
6. Provide definitive shipping instructions.

HOW TO USE THIS MANUAL

Any claim for loss or damage to a shipment in transit should be filed promptly with the transportation company making the delivery. Shipments will be complete unless the packing list or order acknowledgement indicates items back ordered.

If parts received are suspected to be incorrect or defective, please contact the TENNANT representative from whom you ordered the part. They will give authorization for return and/or handle replacement shipments when required.

SECTION 6

CONTENTS

	Page
Fig. 1 – Recommended General Maintenance Items	6-2
Fig. 2 – Replacement Brushes	6-3
Fig. 3 – Hood and Bumper Group	6-4
Fig. 4 – Hood and Bumper Group	6-6
Fig. 5 – Main Frame Group	6-8
Fig. 6 – Main Frame Group	6-9
Fig. 7 – Side Skirt Support Group	6-10
Fig. 8 – Front Shroud Group	6-12
Fig. 9 – Scrub Head Lift Group	6-14
Fig. 10 – Scrub Head Group	6-16
Fig. 11 – Tire and Rim Assembly	6-17
Fig. 12 – Dual Drive Group	6-18
Fig. 13 – Solution and Recovery Tanks Group	6-20
Fig. 14 – Recovery Tank Float Group	6-22
Fig. 15 – Solution Control Group	6-24
Fig. 16 – Battery Group	6-26
Fig. 17 – Battery Group	6-28
Fig. 18 – Steering Control Group	6-30
Fig. 19 – Rear Electrical Panel Group	6-32
Fig. 20 – Electrical Controller Group	6-34
Fig. 21 – Rear Electrical Group	6-35
Fig. 22 – Rear Squeegee Link Group	6-36
Fig. 23 – Rear Squeegee Link Group	6-38
Fig. 24 – Rear Squeegee Group	6-40
Fig. 25 – Wire Harness Group	6-42
Fig. 26 – Label Group	6-44

Fig. 1 – Recommended General Maintenance Items

Ref.	Tennant Part No.	Machine Serial Number	Description	Qty.
▽	11484	(030000–030155)	Squeegee Blade Kit, Short	1
▲	04894	(030000–030155)	Squeegee Blade Assembly, Front	1
▲	04898	(030000–030155)	Squeegee Blade Assembly, Rear	1
▲	33437	(030000–030155)	Blade, Squeegee End	2
▽	24686	(030156–)	Squeegee Blade Kit, Long	1
▲	33357	(030156–)	Squeegee Blade Assembly, Front	1
▲	33352	(030156–)	Squeegee Blade Assembly, Rear	1
▲	11283	(030156–)	Blade, Squeegee End	2
	78544	(030156–)	Squeegee Blade Assembly, Front, Urethane	1
	78545	(030156–)	Squeegee Blade Assembly, Rear, Urethane	1

Fig. 2 – Replacement Brushes

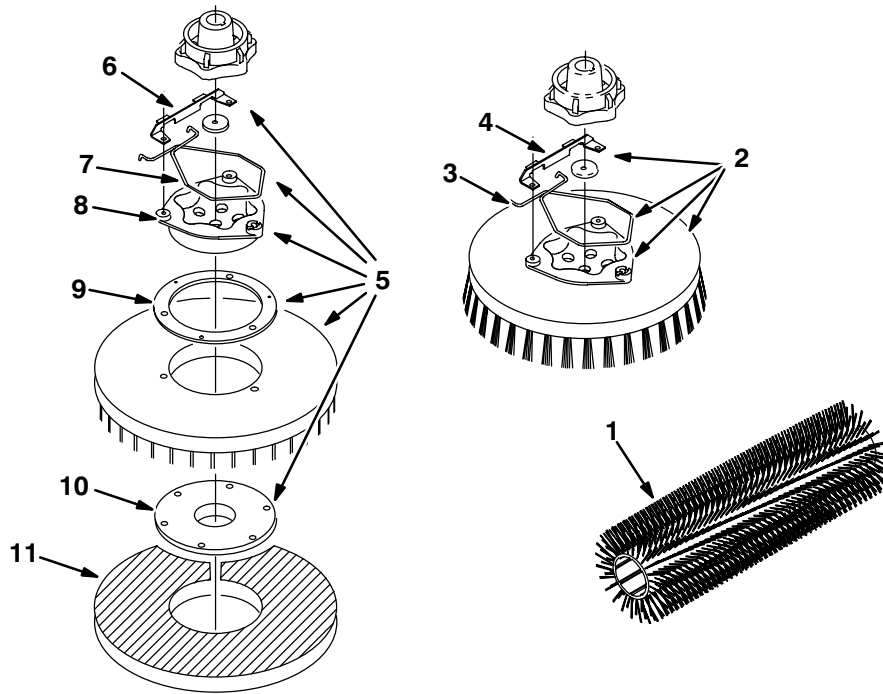

05103/05105

Ref.	Tennant Part No.	Machine Serial Number	Description	Qty.
1	11681	(000000-)	Brush, Pre-Sweep, Polypropylene	1
▽	2	05729	(000000-) Scrub Brush Assembly, Stiff Polypropylene	2
▲	3	14838	(000000-) Spring, Brush, Retaining	1
▲	4	24299	(000000-) Bracket, Spring, Retainer	1
▽	30240	(000000-) Scrub Brush Assembly, Polypropylene	2	
▲	14838	(000000-) Spring, Brush, Retaining	1	
▲	24299	(000000-) Bracket, Spring, Retainer	1	
▽	05728	(000000-) Scrub Brush Assembly, Nylon	2	
▲	14838	(000000-) Spring, Brush, Retaining	1	
▲	24299	(000000-) Bracket, Spring, Retainer	1	
▽	05730	(000000-) Scrub Brush Assembly, Abrasive Nylon	2	
▲	14838	(000000-) Spring, Brush, Retaining	1	
▲	24299	(000000-) Bracket, Spring, Retainer	1	
▽	05033	(000000-) Scrub Brush Assembly, Bassine	2	
▲	14838	(000000-) Spring, Brush, Retaining	1	
▲	24299	(000000-) Bracket, Spring, Retainer	1	
▽	05034	(000000-) Scrub Brush Assembly, Wire	2	
▲	14838	(000000-) Spring, Brush, Retaining	1	
▲	24299	(000000-) Bracket, Spring, Retainer	1	
▽	5	30215	(000000-) Scrub Driver Pad Assembly, Polypropylene	2
▲	6	24299	(000000-) Bracket, Retainer Spring	1
▲	7	14838	(000000-) Spring, Brush Retaining	1
▲	8	15539	(000000-) Adaptor, Brush	1
▲	9	11218	(000000-) Spacer, Pad Holder	1
▲	10	19783	(000000-) Holder, Pad	1
	11	89046	(000000-) Pad, Stripper, Brown	2
		89047	(000000-) Pad, Scrubber, Blue	2
		89048	(000000-) Pad, Buffer, Red	2
		89049	(000000-) Pad, Polish, White	2

Fig. 3 – Hood and Bumper Group

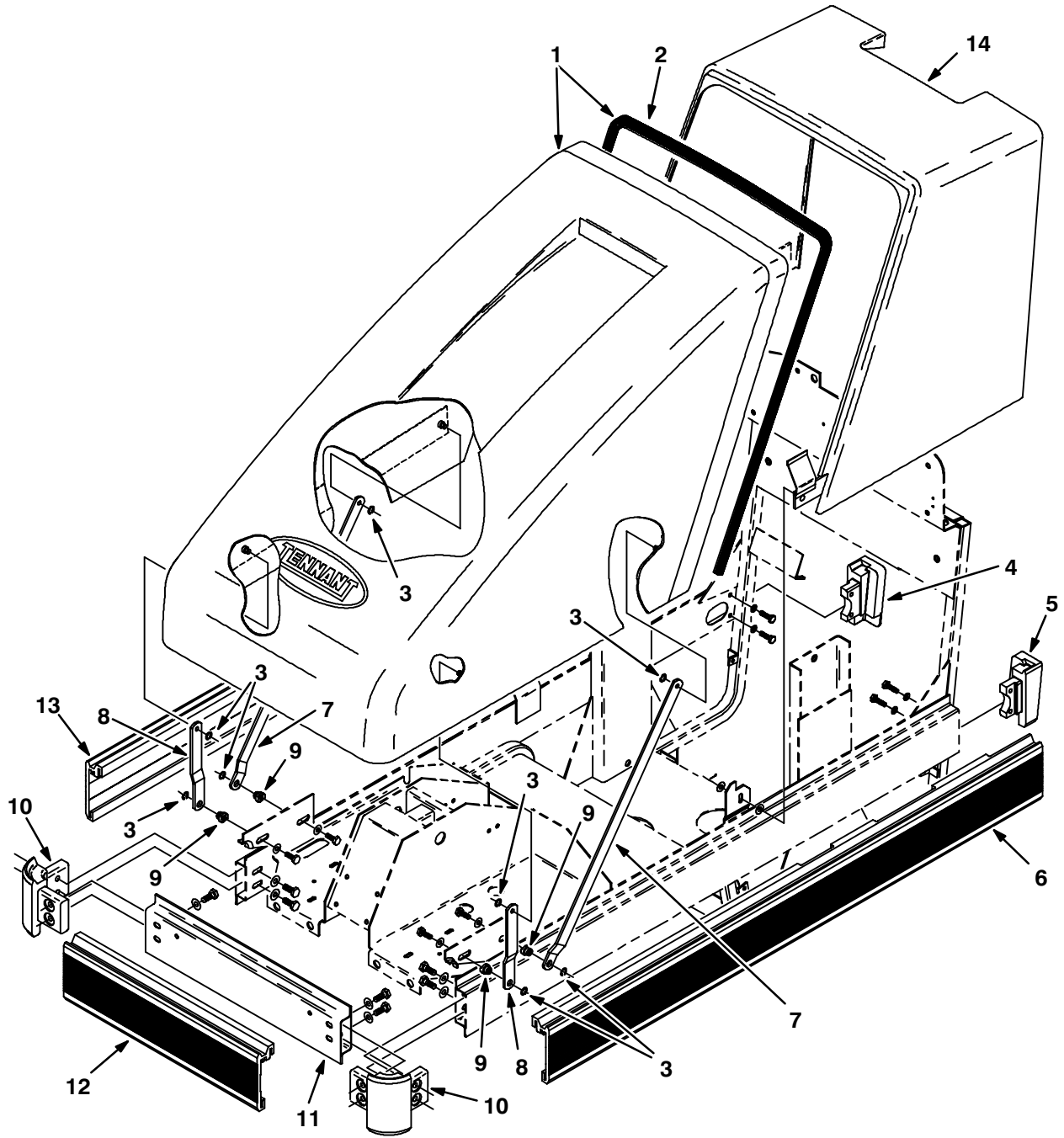

Fig. 3 – Hood and Bumper Group

	Ref.	Tennant Part No.	Machine Serial Number	Description	Qty.
▽	1	05575	(030000-030172)	Cover, Front	1
▲	2	33360	(030000-030172)	Seal	1
	3	05284	(030000-030172)	Clip, Retainer	8
	4	10987	(030000-030172)	Corner Block, Frame, R.H.	1
	5	10988	(030000-030172)	Corner Block, Frame, L.H.	1
	6	05070	(030000-030172)	Bumper, Side, L.H.	1
	7	05236	(030000-030172)	Bar, Long Hinge	2
	8	05223	(030000-030172)	Bar, Short Hinge	2
	9	05272	(030000-030172)	Spacer, Hinge	4
	10	04945	(030000-030172)	Block Assembly, Corner Frame	2
	11	04993	(030000-030172)	Channel, Frame	1
	12	05072	(030000-030172)	Bumper, Front	1
	13	05276	(030000-030172)	Bumper, Side, R.H.	1
	14	05285	(030000-030172)	Cover, Rear	1

Fig. 4 – Hood and Bumper Group

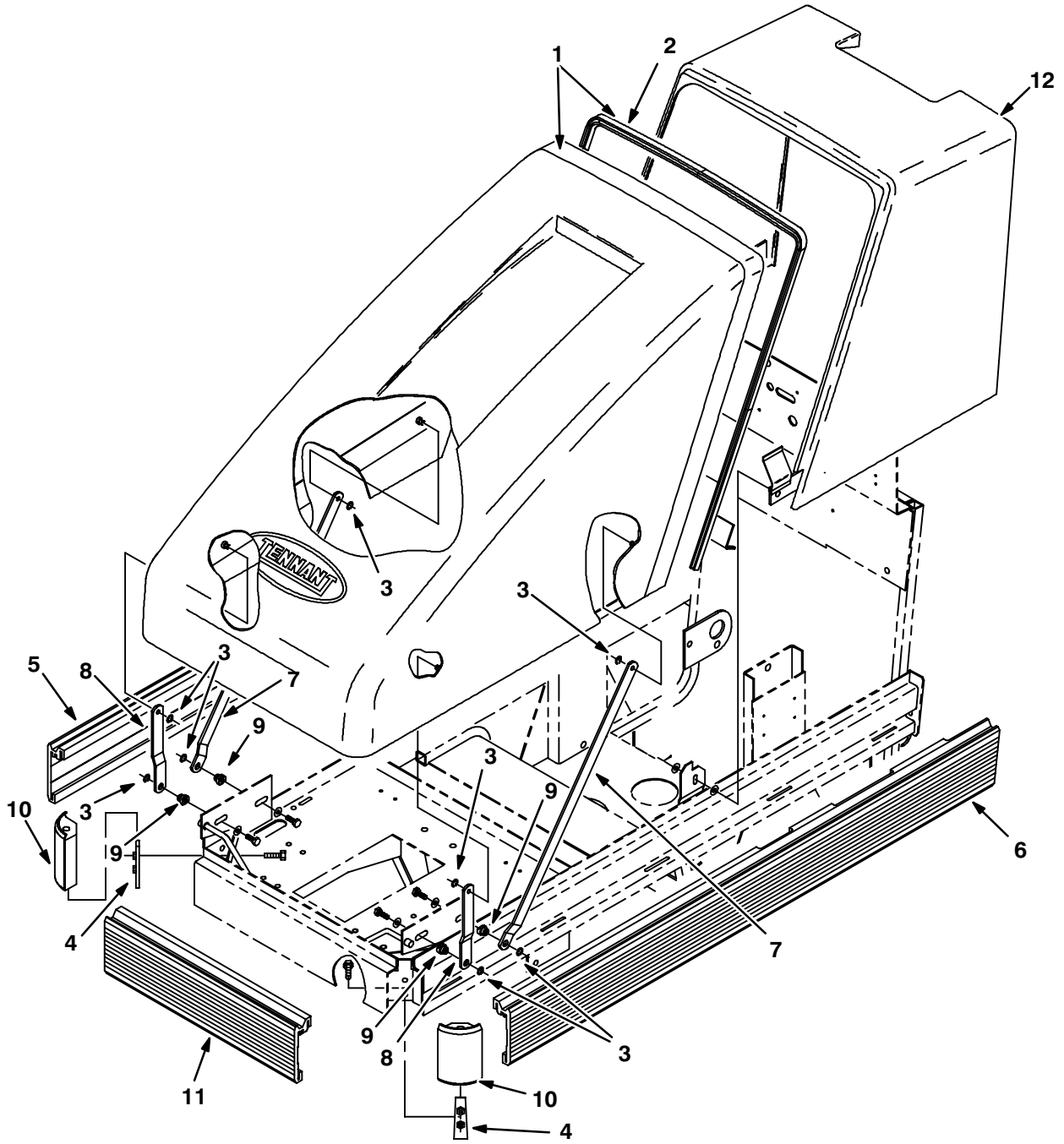
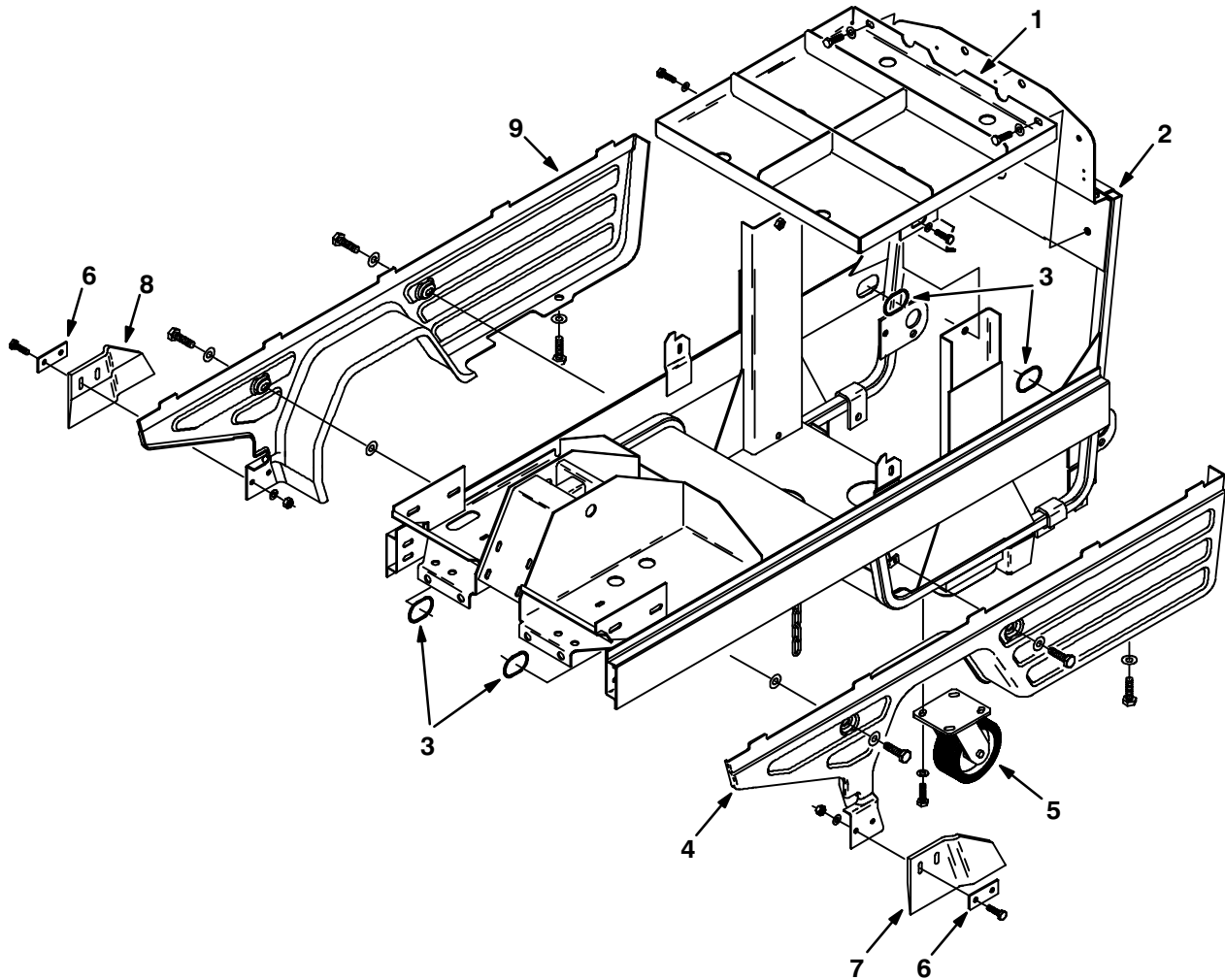

Fig. 4 – Hood and Bumper Group

	Ref.	Tennant Part No.	Machine Serial Number	Description	Qty.
▽	1	05575	(030173–)	Cover, Front	1
▲	2	33360	(030173–)	Seal	1
	3	05284	(030173–)	Clip, Retainer	8
	4	33454	(030173–)	Plate, Mount	2
	5	33537	(030173–)	Bumber, Side, R.H.	1
	6	33536	(030173–)	Bumper, Side, L.H.	1
	7	05236	(030173–)	Bar, Hinge Long	2
	8	05223	(030173–)	Bar, Hinge Short	2
	9	05272	(030173–)	Spacer, Hinge	4
	10	33407	(030173–)	Block, Corner Frame	2
	11	05072	(030173–)	Bumper, Front	1
	12	05285	(030173–)	Cover, Rear	1

Fig. 5 – Main Frame Group



05041/04197

Ref.	Tennant Part No.	Machine Serial Number	Description	Qty.
1	05006	(030000-030172)	Tray, Battery	1
2	24863	(030000-030172)	Frame Replacement Kit	1
3	27929	(030000-030172)	Grommet	4
4	05048	(030000-030172)	Panel, Lower, L.H.	1
5	65690	(030000-030172)	Caster	2
6	10931	(030000-030172)	Strip, Skirt Retainer	2
7	10929	(030000-030172)	Skirt, Lower Panel, L.H.	1
8	10930	(030000-030172)	Skirt, Lower Panel, R.H.	1
9	05047	(030000-030172)	Panel, Lower, R.H.	1

Fig. 6 – Main Frame Group

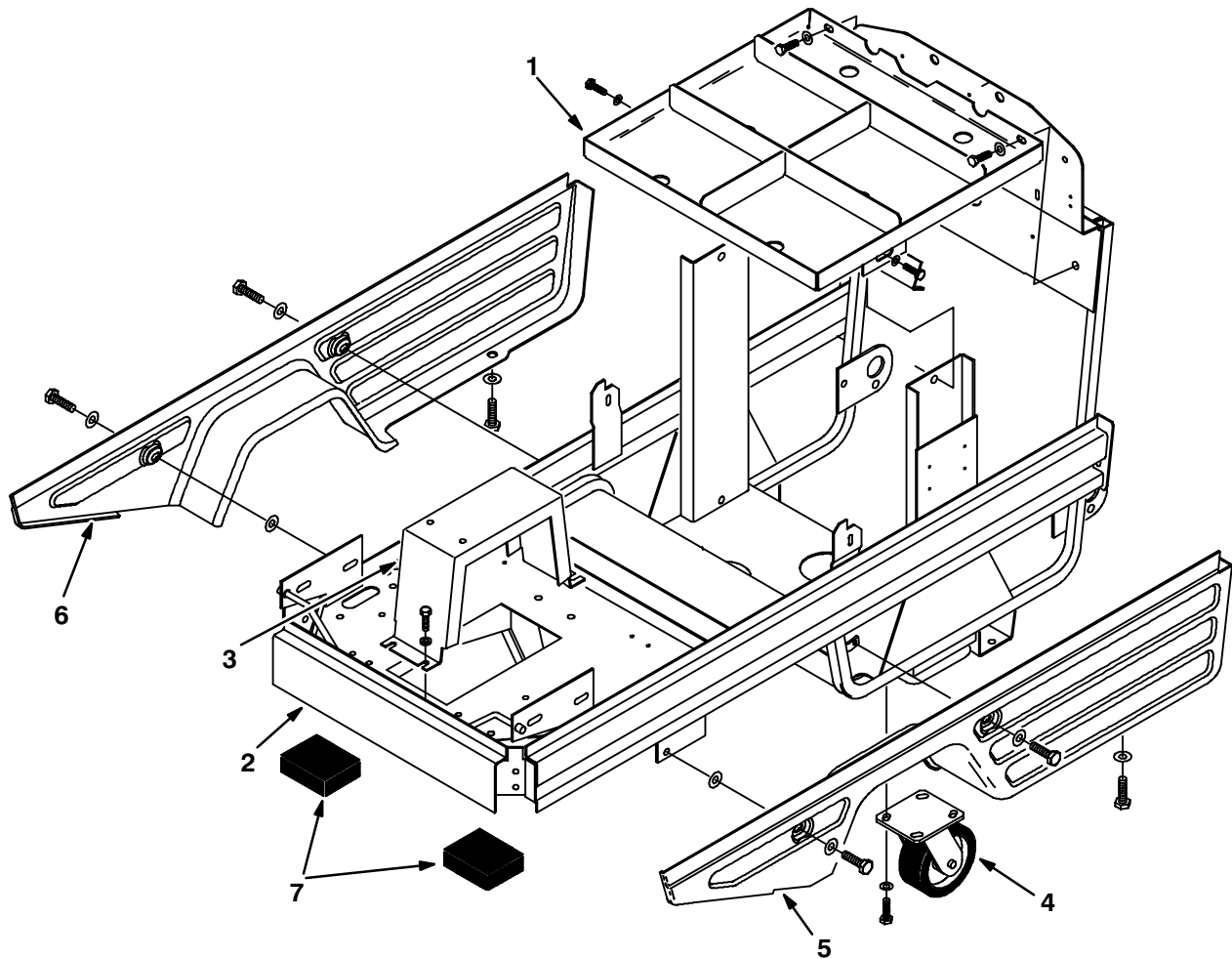

06169/06982

Ref.	Tennant Part No.	Machine Serial Number	Description	Qty.
1	05006	(030173–)	Tray, Battery	1
2	33490	(030173–)	Frame, Main	1
3	33515	(030173–)	Channel	1
4	65690	(030173–)	Caster	2
5	33548	(030173–)	Panel, Cover, L.H.	1
6	33583	(030173–)	Panel, Lower, R.H.	1
7	04702	(030173–)	Pad, Head Stop	2

Fig. 7 – Side Skirt Support Group

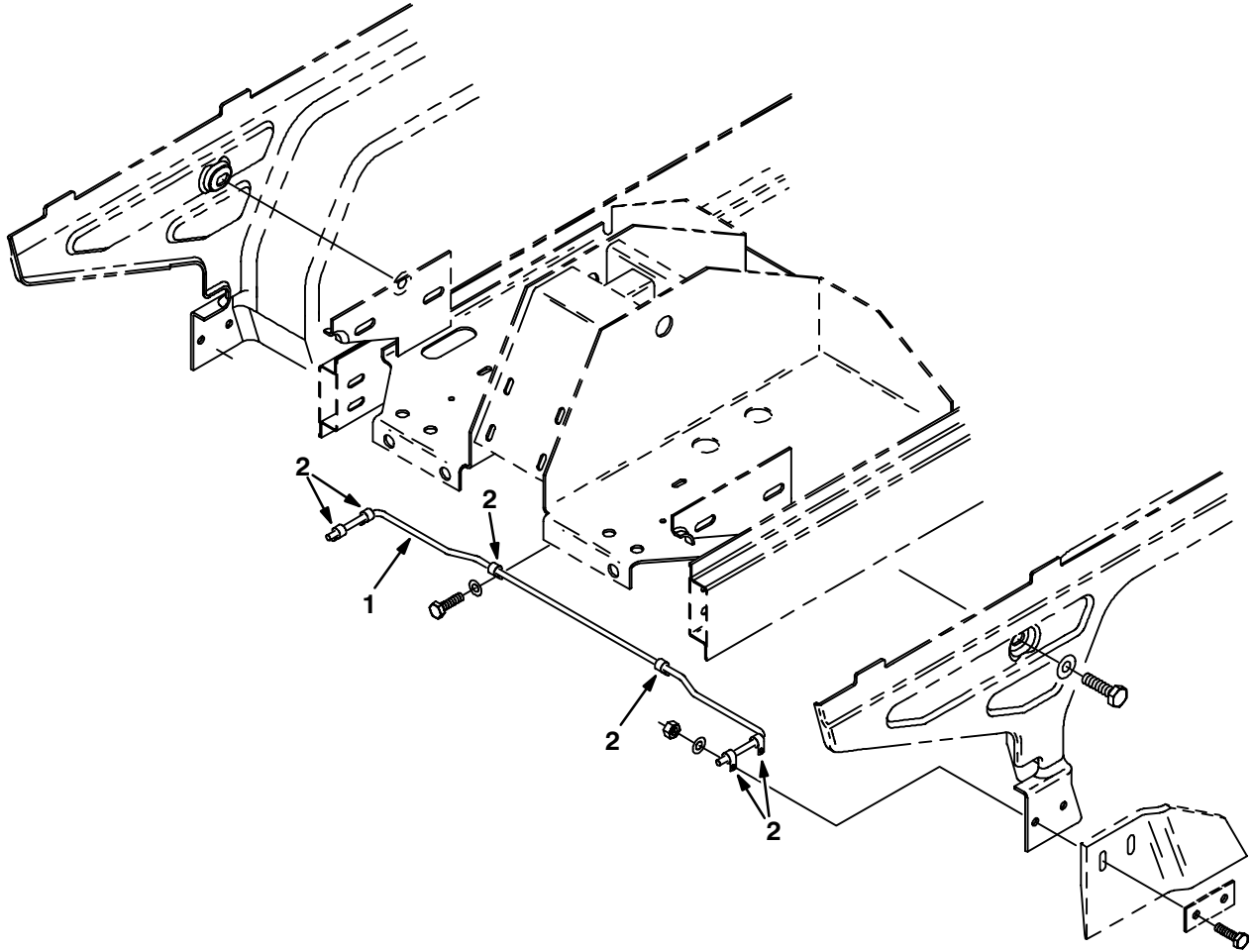

Fig. 7 – Side Skirt Support Group

Ref.	Tennant Part No.	Machine Serial Number	Description	Qty.
1	05646	(030000–030172)	Spring, Skirt Mounting	1
2	46236	(030000–030172)	Clamp, Cable	6

Fig. 8 – Front Shroud Group

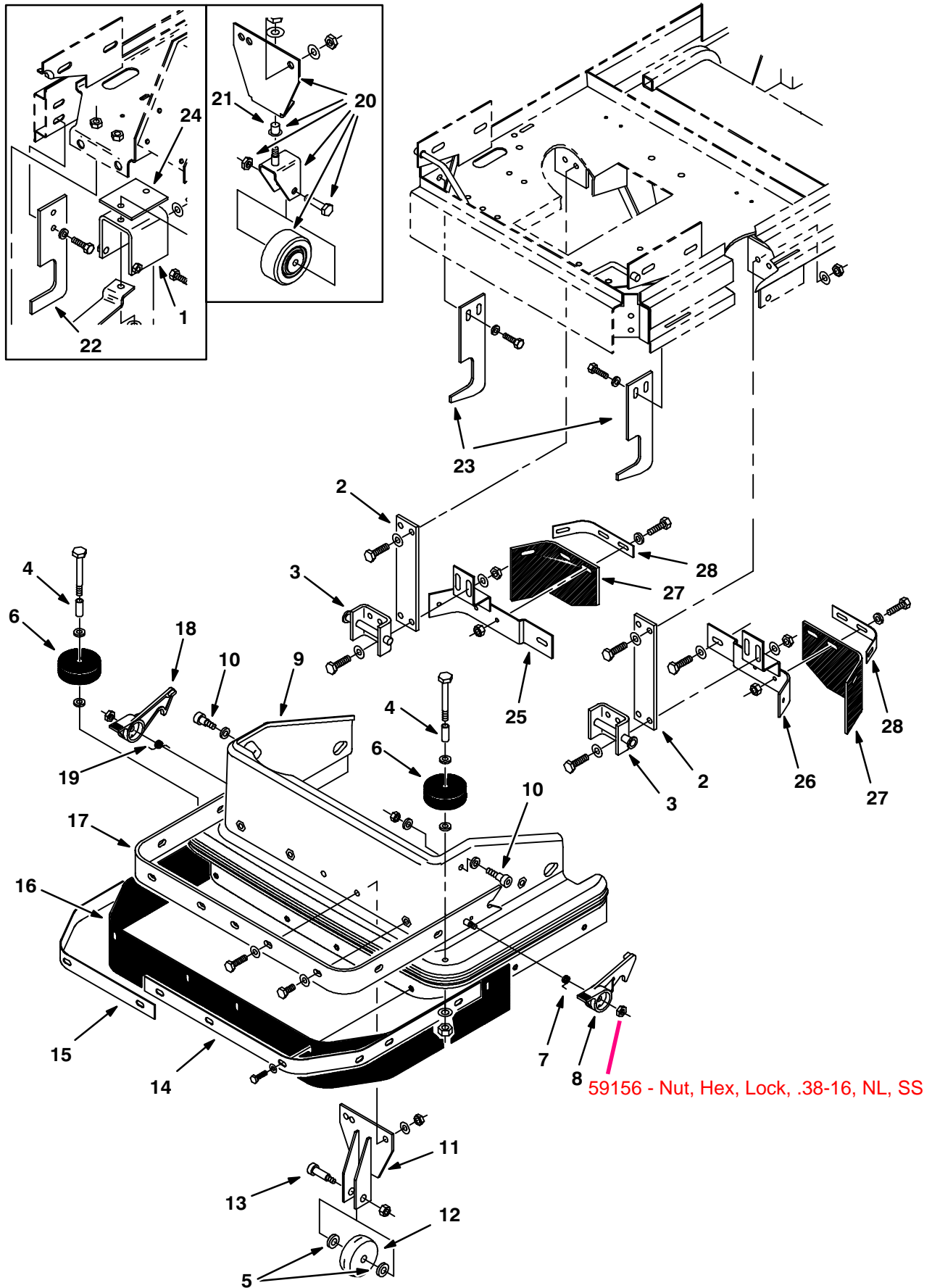

Fig. 8 – Front Shroud Group

Ref.	Tennant Part No.	Machine Serial Number	Description	Qty.
1	06103	(030000–030172)	Bracket, Spring Mounting	2
2	06108	(030000–)	Spring	2
3	05214	(030000–)	Bracket, Shroud Mounting	2
▽	28496	(030000–)	Scrub Shroud Replacement Kit	1
▲	4	33427	(030000–) Sleeve	2
▲	5	59633	(030131–) Bearing, Fiberglide Thrust	2
▲	6	86800	(030000–) Wheel	2
▲	7	10927	(030000–) Spring, Torsion, L.H.	1
▲	8	11613	(030000–) Latch, Shroud, L.H.	1
▲	9	28494	(030000–) Panel, Scrub Shroud	1
▲	10	36758	(030131–) Screw, Shoulder	2
▲	11	28365	(030131–) Bracket, Wheel	1
▲	12	86800	(030131–) Wheel	1
▲	13	86791	(030131–) Screw, Shoulder	1
▲	14	05222	(030000–) Strip, Skirt Retainer, L.H.	1
▲	15	05233	(030000–) Strip, Skirt Retainer, R.H.	1
▲	16	05240	(030000–) Skirt, Scrub Head	1
▲	17	05050	(030000–) Strap, Shroud	1
▲	18	11612	(030000–) Latch, Shroud, R.H.	1
▲	19	10928	(030000–) Spring, Torsion, R.H.	1
20	28360	(030000–030172)	Wheel Replacement Kit	1
21	11489	(030000–030172)	Bearing, Flanged	1
22	28366	(030131–030172)	Plate, Shroud	2
23	24852	(030173–)	Plate, Mount	2
24	28238	(030000–030172)	Plate, Spacer	2
25	33535	(030173–)	Bracket, Skirt, R.H.	1
26	33533	(030173–)	Bracket, Skirt, L.H.	1
27	33532	(030173–)	Skirt, Side	2
28	33477	(030173–)	Strip, Backup	2

Fig. 9 – Scrub Head Lift Group

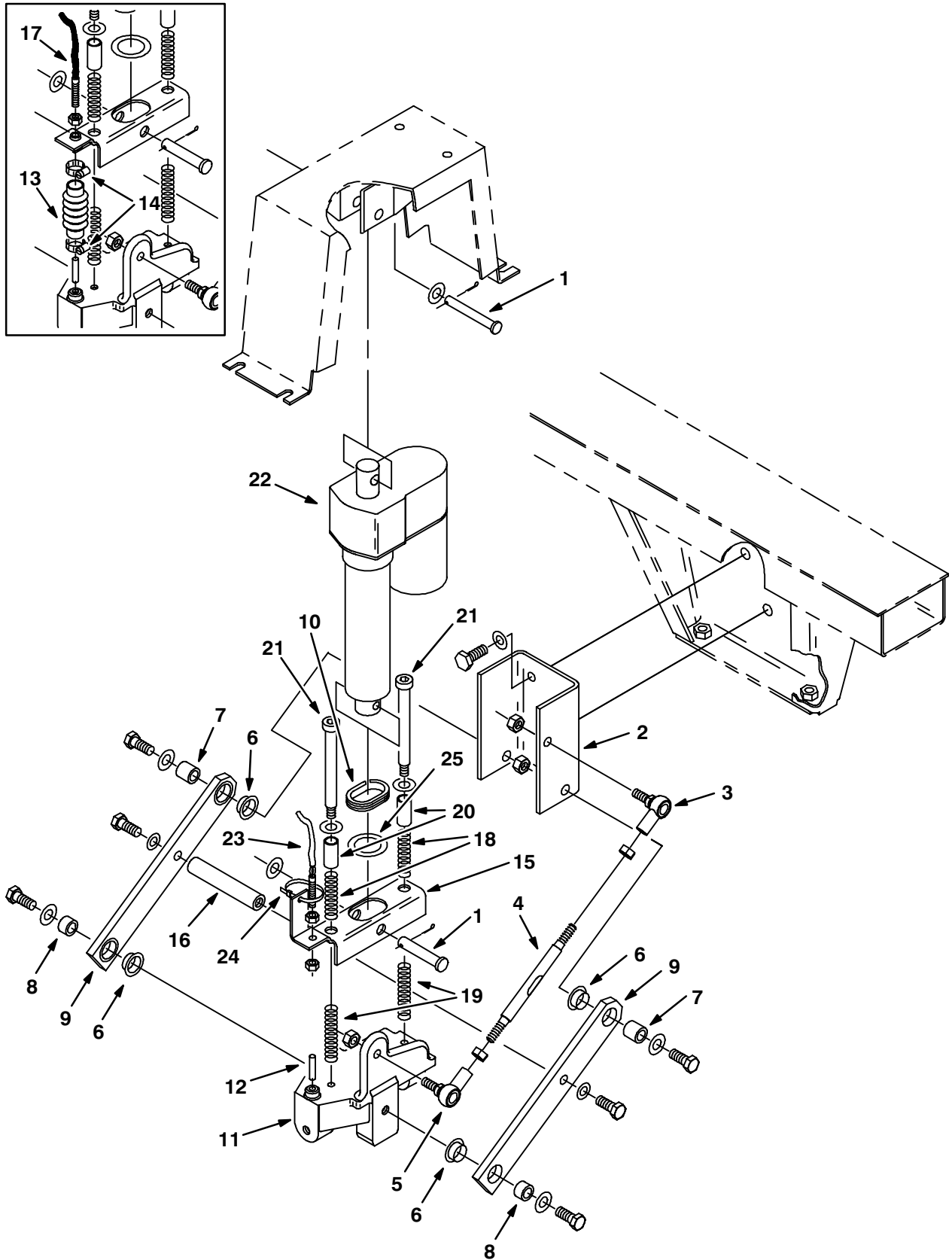
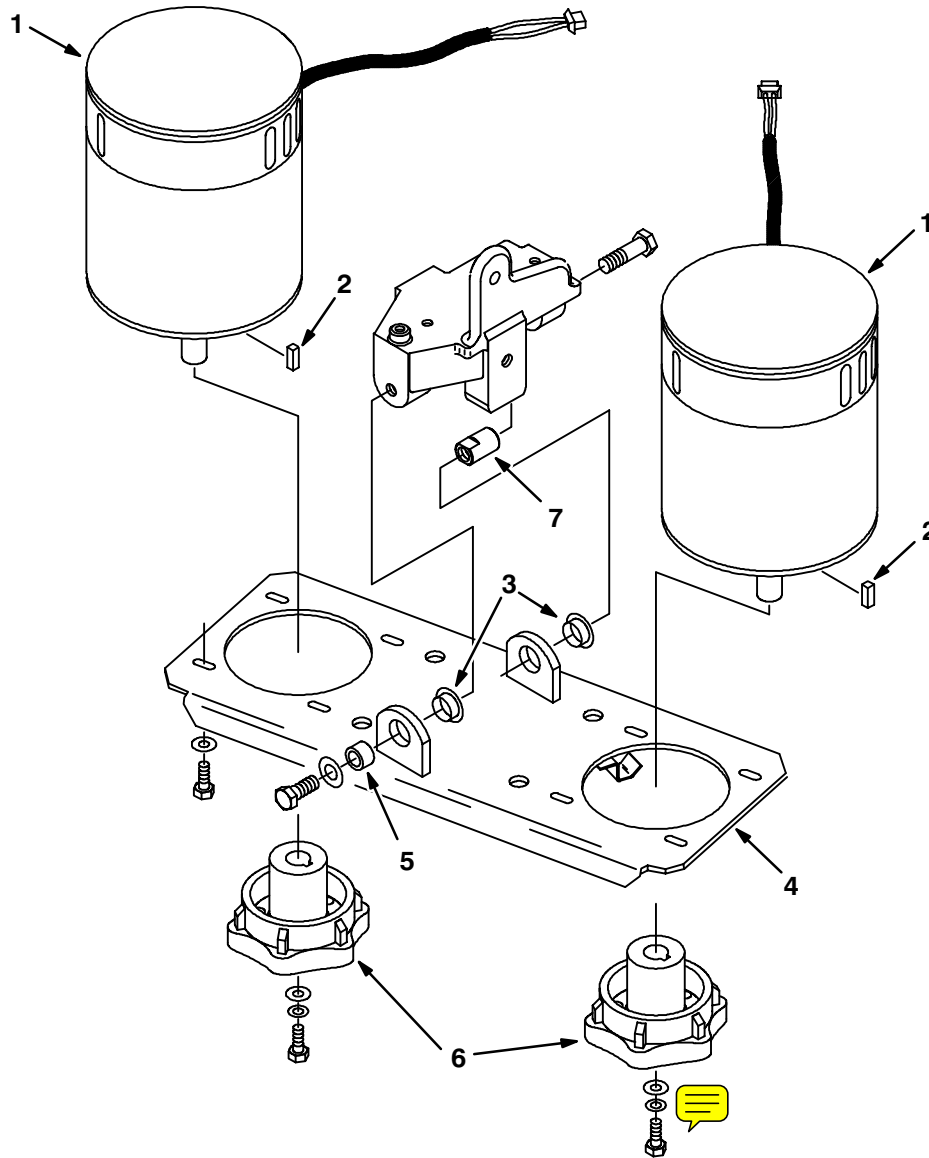

Fig. 9 – Scrub Head Lift Group

Ref.	Tennant Part No.	Machine Serial Number	Description	Qty.
1	51534	(030000–) Pin, Clevis	1
2	05292	(030000–) Bracket, Link Mount	1
3	05685	(030000–) Rod End, M10, L.H.	1
4	04921	(030000–) Rod, Adjusting	1
5	05686	(030000–) Rod End, M10, R.H.	1
6	04928	(030000–) Bearing, Flange	4
7	05019	(030000–) Sleeve	2
8	04927	(030000–) Sleeve	2
9	04920	(030000–) Bar, Pivot	2
10	10632–14	(030000–) Grommet	1
11	04924	(030000–) Pivot, Scrub Head	1
12	05735	(030000–) Magnet, Switch	1
13	54333	(030000–030174) Clamp, Worm Drive	2
14	05793	(030000–030174) Boot, Switch (replaced by none)	1
15	28577	(030000–) Bracket, Head Lift	1
16	04942	(030000–) Spacer, Rod	1
17	28609	(030000–030174) Sensor Kit	1
18	45261	(030000–) Spring, Compression	2
19	63185	(030000–) Spring, Compression	2
20	50682	(030000–) Sleeve	2
21	45960	(030000–) Screw, Shoulder	2
22	05018	(030000–) Actuator, 36 V	1
23	28608	(030175–) Sensor Assembly, Mag Reed	1
24	49266	(030175–) Tie, Cable	1
25	27921	(030000–) Washer	1

Fig. 10 – Scrub Head Group



04224/05093

Ref.	Tennant Part No.	Machine Serial Number	Description	Qty.
1	04922	(030000–)	Motor, 36 V (See Breakdowns)	2
2	00926	(030000–)	Key, Square	2
3	04928	(030000–)	Bearing, Flange	2
4	05075	(030000–)	Plate, Brush Drive	1
5	04927	(030000–)	Sleeve	1
6	14841	(030000–)	Hub, Brush Drive	2
7	05612	(030000–)	Sleeve, Scrub Head Rear	1

Fig. 11 – Tire and Rim Assembly

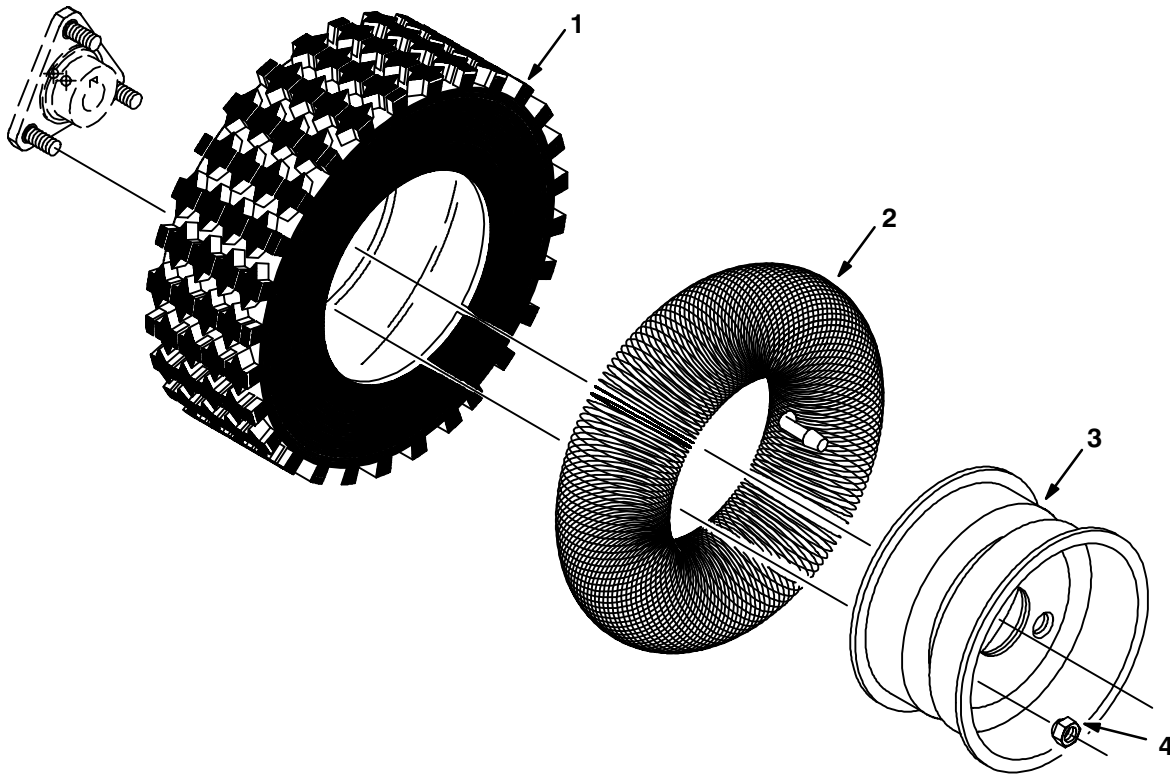

04781/04200

	Ref.	Tennant Part No.	Machine Serial Number	Description	Qty.
▽		61597	(030000–) Tire and Rim Assembly	2
▲	1	61596	(030000–) Tire, Non-marking	1
▲	2	04658	(030000–) Tube, Inner	1
▲	3	04657	(030000–) Rim	1
	4	11109	(030000–) Nut, Wheel	6

Fig. 12 – Dual Drive Group

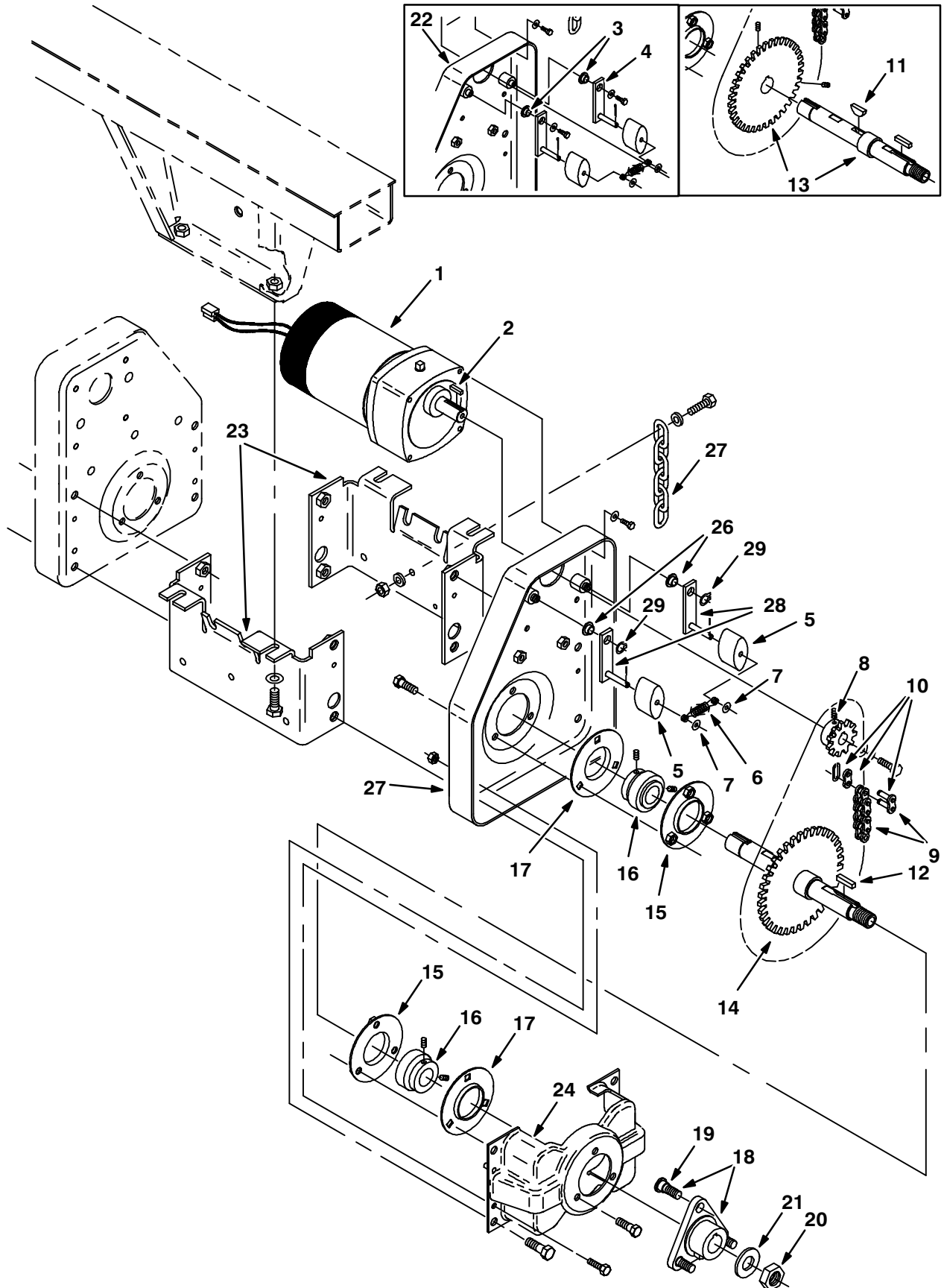

Fig. 12 – Dual Drive Group

Ref.	Tennant Part No.	Machine Serial Number	Description	Qty.
1	04656	(030000–)	Motor, Electric (See Breakdowns)	2
2	00911	(030000–)	Key, Square	2
3	05582	(030000–030186)	Bearing, Flange	4
4	24548	(030000–030186)	Arm Kit, Chain Tensioner	4
5	04671	(030000–)	Puck, Chain Tensioner	4
6	04720	(030000–)	Spring, Compression	2
7	05604	(030000–)	Wire, Spring	4
8	04672	(030000–)	Sprocket	2
▽	9	61415	(030000–) Chain and Link Assembly	2
▲	10	28272	(030000–) Link, Roller Chain	1
11	00500–15	(030000–030157)	Key, Woodruff	2
12	00928	(030000–)	Key, Square	2
13	33484	(030000–030157)	Shaft and Sprocket Replacement Kit	2
14	33422	(030158–)	Shaft and Sprocket	2
15	04746	(030000–)	Flange, Bearing Retainer	4
16	24684	(030000–)	Bearing Replacement Kit	4
17	36190	(030000–)	Flange	4
▽	18	04704	(030000–) Dual Drive Hub Assembly	2
▲	19	11117	(030000–) Stud, Wheel	3
20	08169	(030000–)	Nut, Nylon Lock	2
21	04401	(030000–)	Washer, M20	2
22	24549	(030000–030186)	Housing, Chain	2
23	05572	(030000–)	Bracket, Drive Mounting	2
24	11088	(030000–)	Bracket, Bearing Support	2
25	47277	(030173–)	Chain, Static	1
26	15877	(030187–)	Bearing, Flange	4
27	33446	(030187–)	Case, Chain	2
28	24547	(030187–)	Arm, Chain Tensioner	4
29	24555	(030187–)	E–Ring, External	4

Fig. 13 – Solution and Recovery Tanks Group

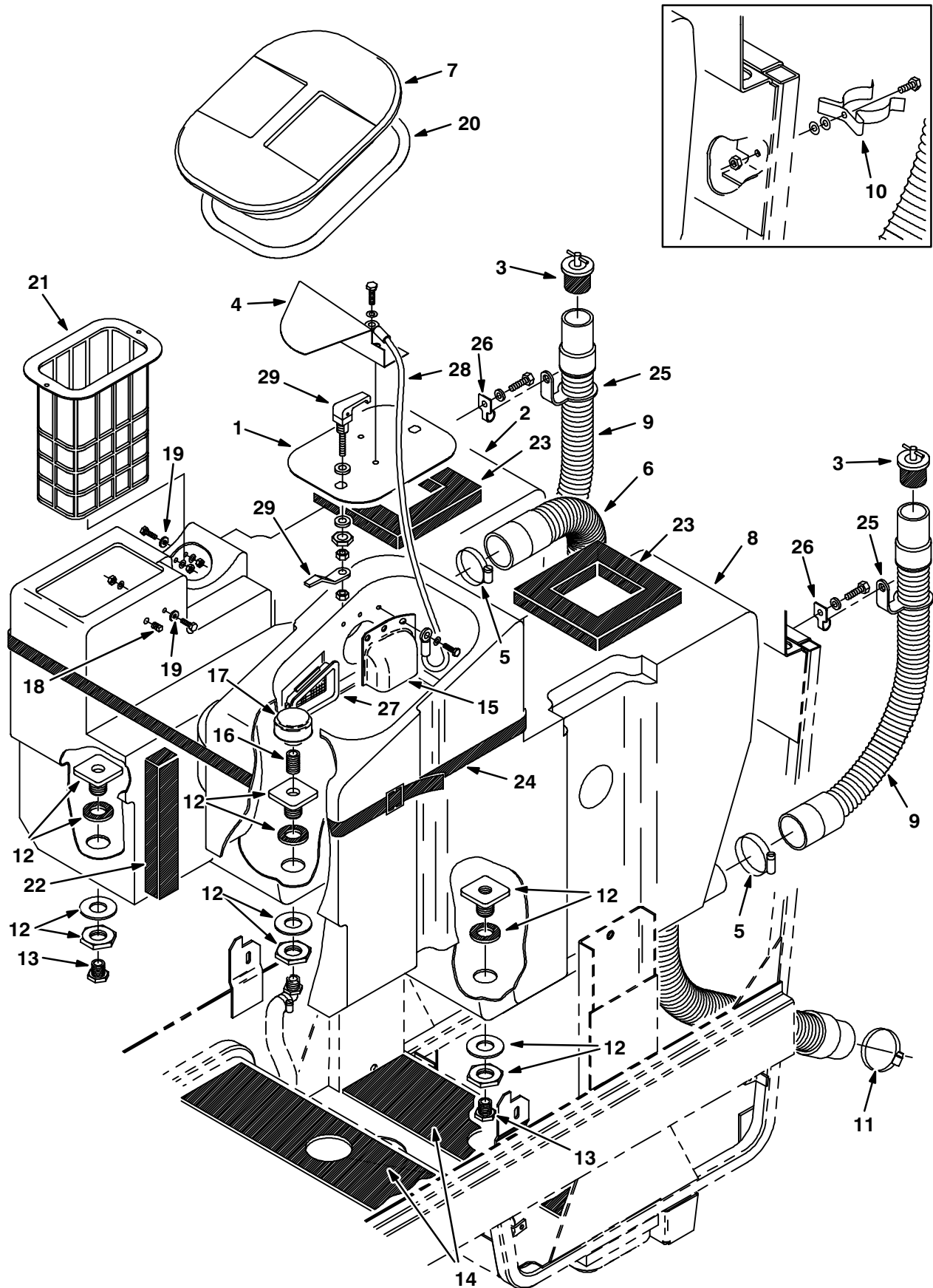

Fig. 13 – Solution and Recovery Tanks Group

Ref.	Tennant Part No.	Machine Serial Number	Description	Qty.
1	65552	(030000–030311)	Baffle Kit	1
1	65551	(030312–)	Plate, Baffle	1
2	05014	(030000–)	Tank, Solution	1
3	222396	(030000–)	Stopper Assembly	2
4	11746	(030000–)	Baffle, Tank	1
5	22297	(030000–)	Clamp, Worm Drive	3
6	05216	(030000–)	Hose, Squeegee	1
7	06137	(030000–)	Cover, Recovery Tank	1
8	05015	(030000–)	Tank Recovery	1
9	05127	(030000–)	Hose, Drain	2
10	67004	(030000–030170)	Clip, Finger Grip	2
11	33344	(030000–)	Clamp, Worm Drive	1
12	65566	(030000–)	Fitting, Straight	3
13	75611	(030000–)	Fitting, Plug	2
14	05675	(030000–)	Pad, Tank	2
15	11750	(030000–)	Baffle, Vacuum Fan	1
16	69784	(030000–)	Fitting, Nipple	1
17	05218	(030000–)	Strainer, Solution Tank	1
18	56119	(030000–)	Fitting, Plug	1
19	76426	(030000–)	Washer, Sealing	3
20	05165	(030000–)	Seal, Recovery Tank Lid	1
21	43516A	(030000–)	Basket, Soap	1
22	04832	(030000–)	Pad, Foam	1
23	57828	(030000–)	Foam	2
24	04836	(030000–)	Strip, Poly	1
25	24663	(030171–)	Strap, Drain Hose	2
26	24638	(030171–)	Clip, Drain Hose	2
27	05089	(030000–)	Screen	1
28	19676	(030000–)	Lanyard	1
29	65695	(030312–)	Latch, Lift and Turn, Adjustable	2

Fig. 14 – Recovery Tank Float Group

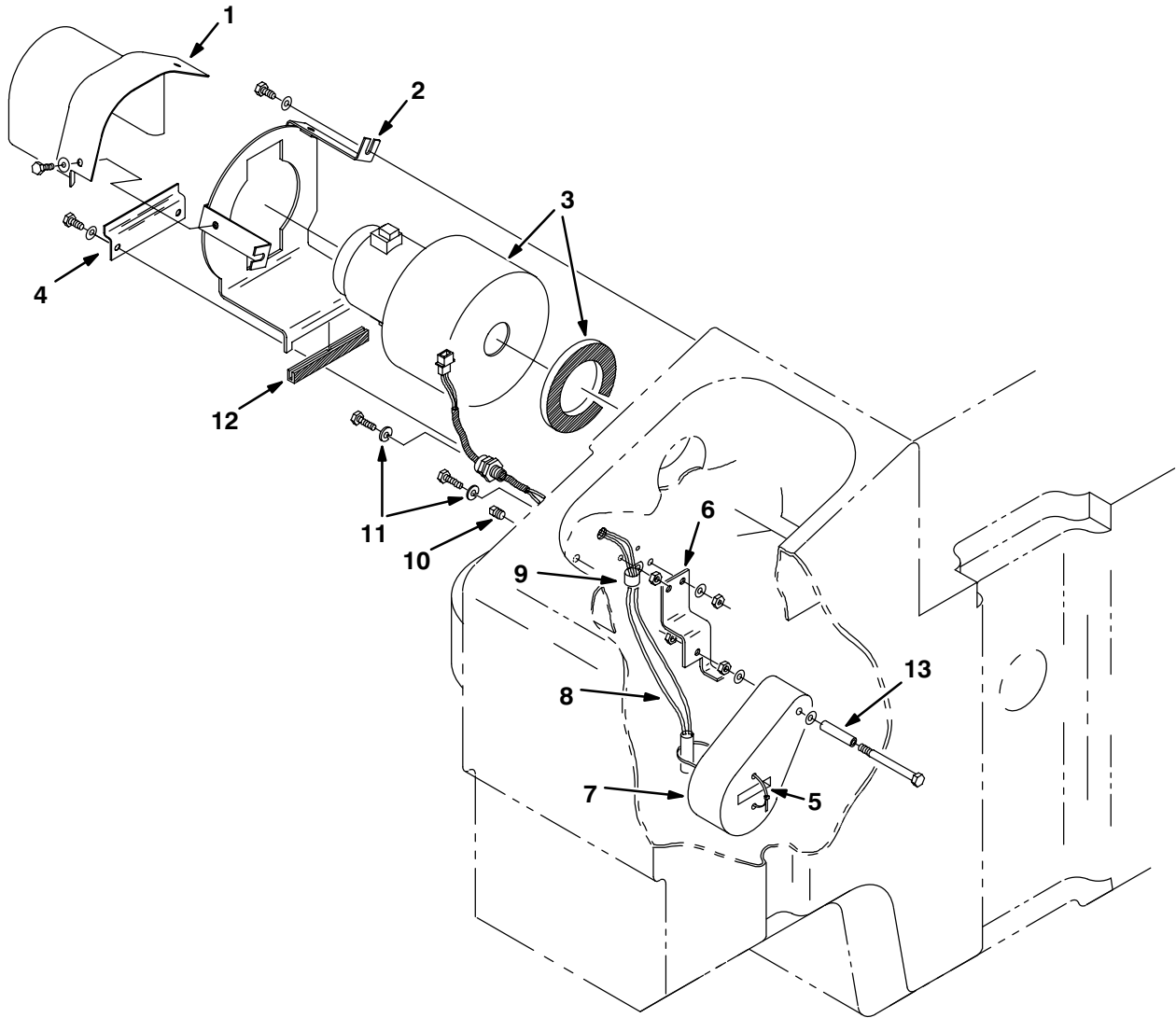

Fig. 14 – Recovery Tank Float Group

Ref.	Tennant Part No.	Machine Serial Number	Description	Qty.
1	10936	(030000–) Guard, Vacuum Fan	1
2	06174	(030000–) Bracket, Vacuum Fan	1
3	10914	(030000–) Fan, Vacuum (See Breakdowns)	1
4	06146	(030000–) Bracket, Mounting	1
5	49266	(030000–) Tie, Cable	1
6	05567	(030000–) Bracket, Water Level Control	1
7	65683	(030000–) Float, Water Level	1
8	10935	(030000–030118) Mercury Switch Assembly	1
8	28346	(030119–) Mercury Switch Assembly	1
9	33584	(030000–) Clamp, Cable	1
10	56119	(030000–) Fitting, Plug	1
11	76426	(030000–) Washer, Sealing	3
12	10911	(030000–) Isolator, Vacuum Fan	1
13	78551	(030000–) Tube	1

Fig. 15 – Solution Control Group

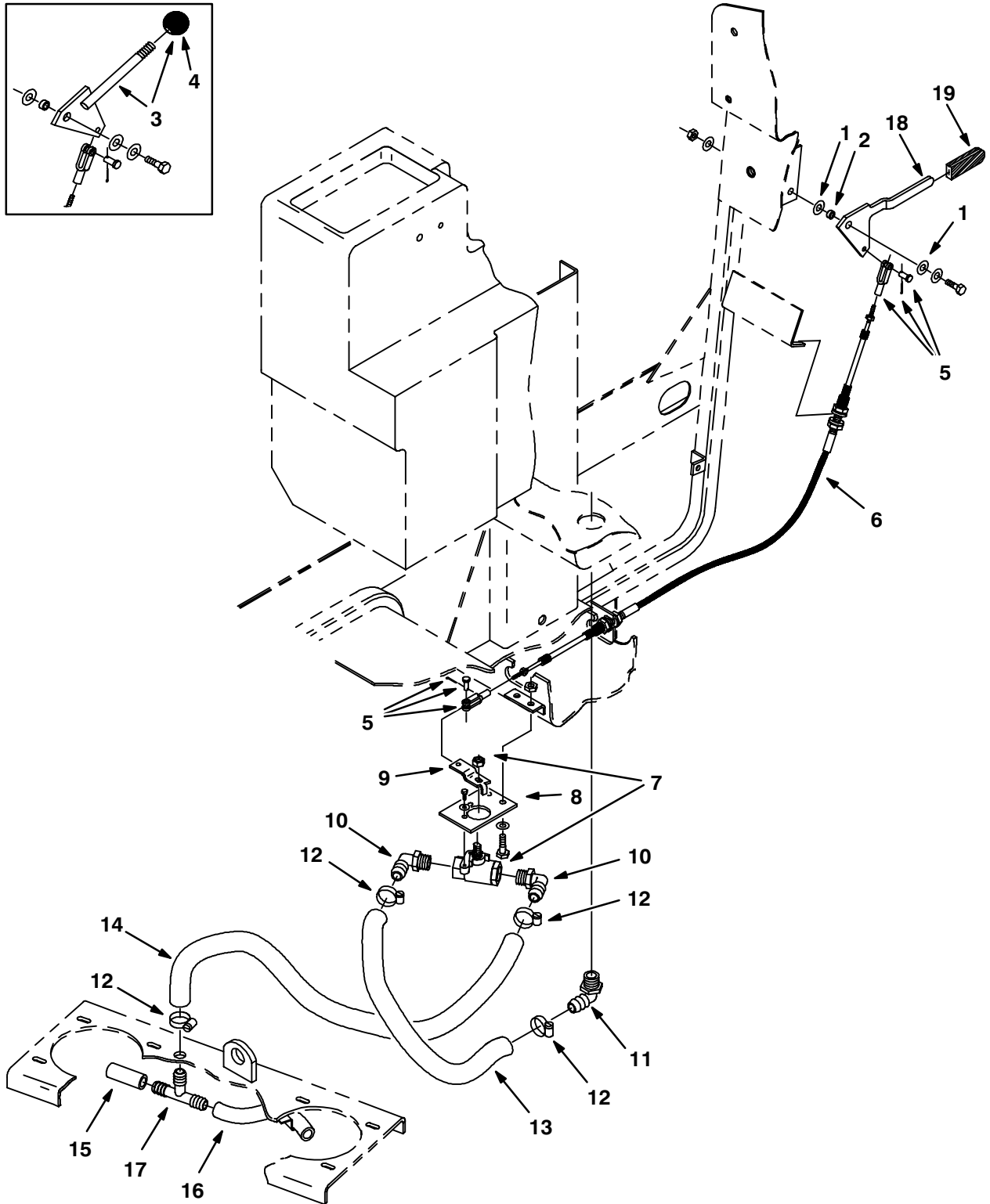

Fig. 15 – Solution Control Group

Ref.	Tennant Part No.	Machine Serial Number	Description	Qty.
1	43611	(030000–)	Washer, Nylon	2
2	63342	(030000–)	Sleeve	1
3	33441	(030000–030140)	Water Handle Kit	1
4	26565	(030000–030140)	Knob	1
5	27880	(030000–)	Yoke Assembly	2
6	05670	(030000–)	Cable, Push Pull	1
7	12083	(030000–)	Water, Valve	1
8	05294	(030000–)	Bracket, Valve Mounting	1
9	05669	(030000–)	Arm, Water Valve	1
10	63244–1	(030000–)	Fitting, Barbed Elbow	2
11	63244–3	(030000–)	Fitting, Barbed Elbow	1
12	54333	(030000–)	Clamp, Worm Drive	4
13	05714	(030000–)	Hose, PVC	1
14	05712	(030000–)	Hose, Clear Vinyl	1
15	05711	(030000–)	Hose, Clear Vinyl	1
16	05715	(030000–)	Hose, Clear Vinyl	1
17	63245–1	(030000–)	Fitting, Barbed Tee	1
18	33438	(030141–)	Lever, Control	1
19	33439	(030141–)	Grip, Handle	1

Fig. 16 – Battery Group

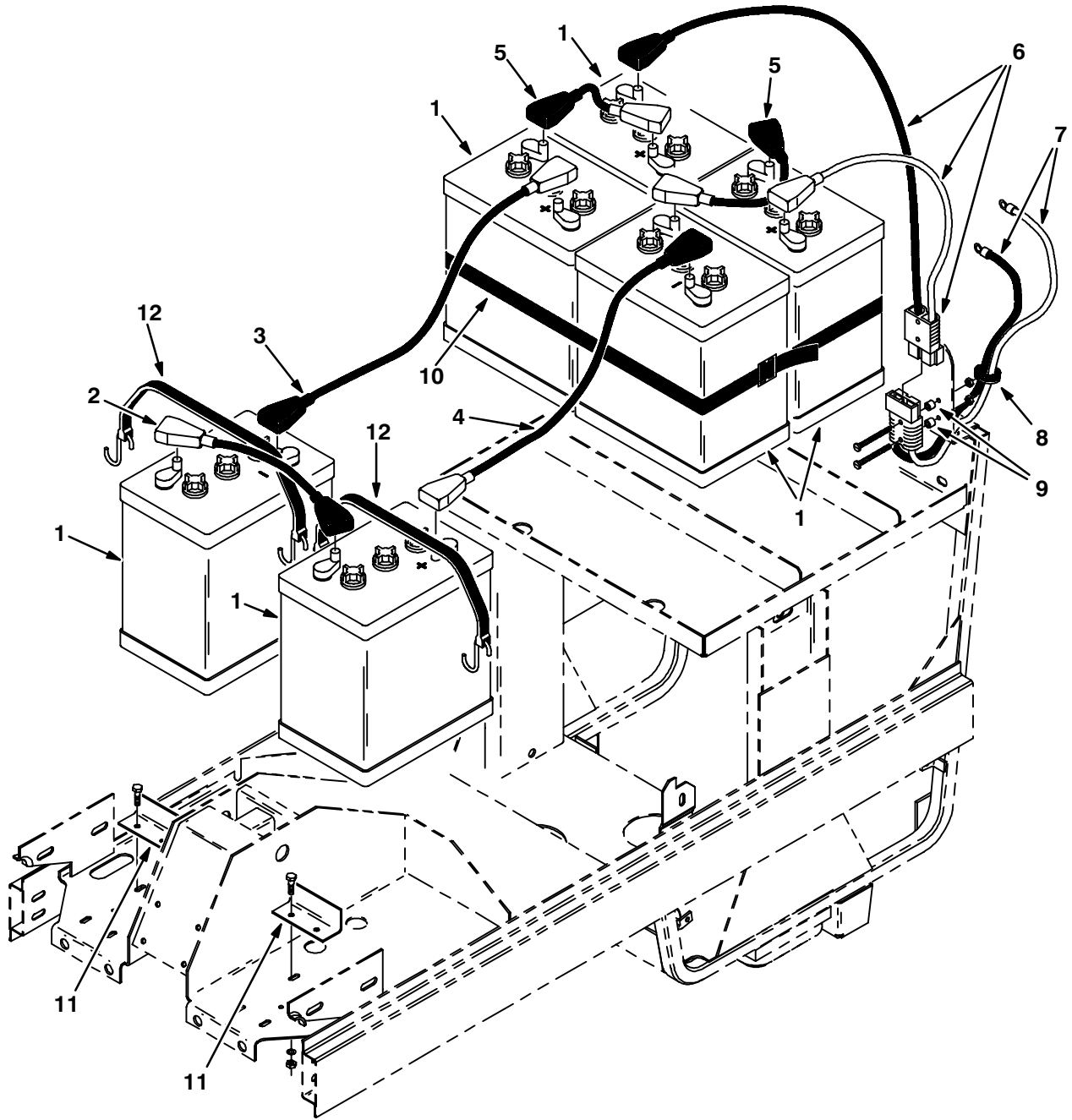

Fig. 16 – Battery Group

Ref.	Tennant Part No.	Machine Serial Number	Description	Qty.
1	11230	(030000-030095)	Battery, 6 V, Wet (Replaced by 10155)	6
1	11229	(030000-030095)	Battery, 6 V, Dry (International Only)	6
2	05251	(030000-030095)	Cable, Battery	1
3	63757	(030000-030095)	Cable, Battery	1
4	05252	(030000-030095)	Cable, Battery	1
5	63755	(030000-030095)	Cable, Battery	2
6	05671	(030000-030095)	Cable, Battery	1
7	05672	(030000-030095)	Cable, Battery	1
8	10632	(030000-030095)	Grommet, Rubber	1
9	65742	(030000-030095)	Sleeve	2
10	04836	(030000-030095)	Strap, Poly, Webbing	1
11	04684	(030000-030095)	Angle, Battery Stop	2
12	33671	(030000-030095)	Strap, Rubber, Tie-down	2

Fig. 17 – Battery Group

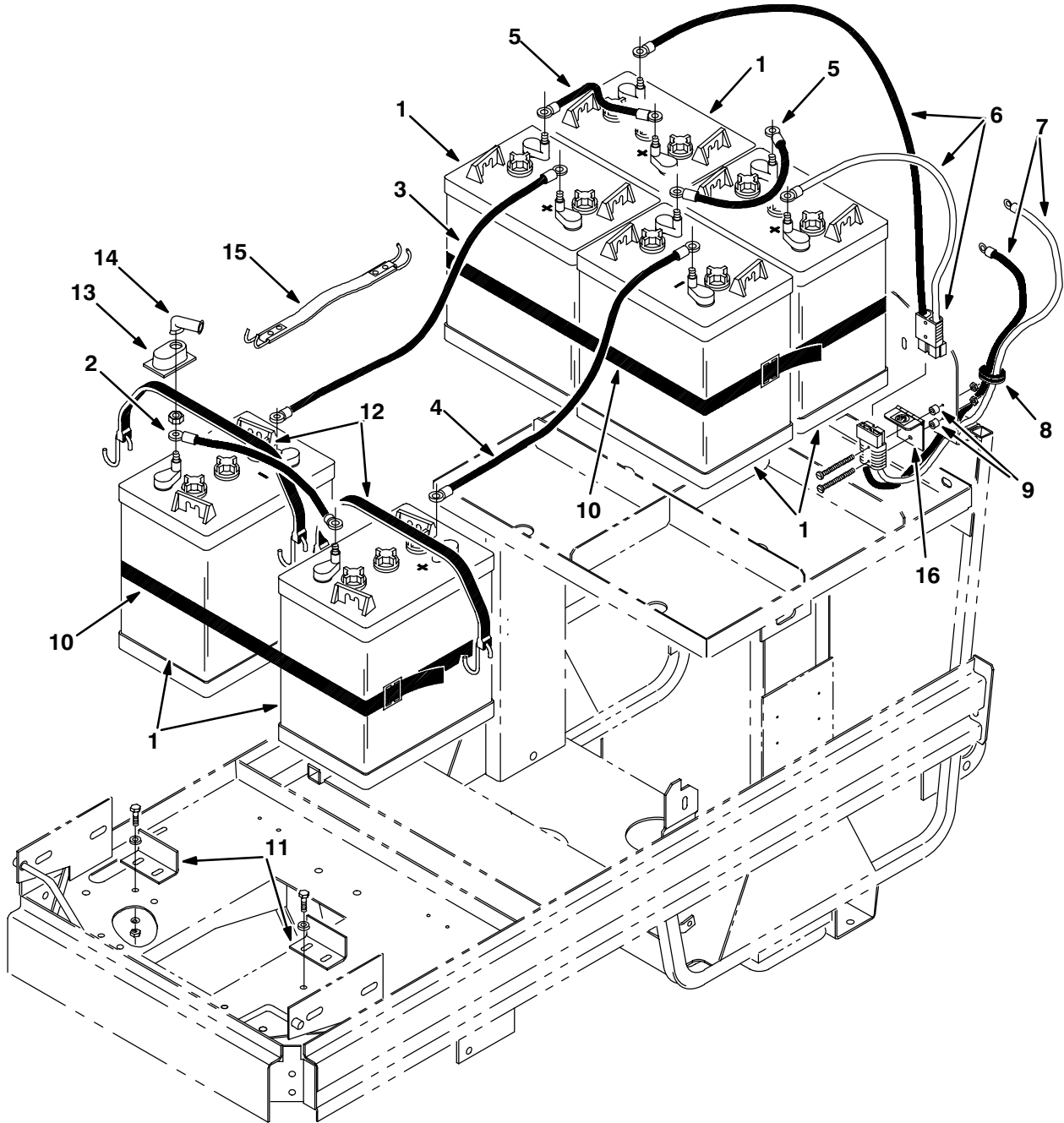

Fig. 17 – Battery Group

Ref.	Tenant Part No.	Machine Serial Number	Description	Qty.
1	10155	(030096–)	Battery, 6 V, Wet	6
1	11229	(030096–)	Battery, 6 V, Dry (International Only)	6
2	28333	(030096–)	Cable, Battery	1
3	28334	(030096–)	Cable, Battery	1
4	28335	(030096–)	Cable, Battery	1
5	63740	(030096–)	Cable, Battery	2
6	28332	(030096–)	Cable, Battery	1
7	05672	(030096–)	Cable, Battery	1
8	10632	(030096–)	Grommet, Rubber	1
9	65742	(030096–)	Sleeve	2
10	04836	(030096–)	Strap, Poly, Webbing	2
11	04684	(030096–030172)	Angle, Battery Stop	2
11	24843	(030173–)	Angle, Battery Stop	2
12	33671	(030096–)	Strap, Rubber, Tie-down	2
13	45962	(030096–)	Cover, Terminal	12
14	02076	(030096–)	Cover, Terminal	12
15	28286	(030096–)	Strap, Battery Lift	1
16	65744	(030096–)	Hinge, W/Label, SB50	1

Fig. 18 – Steering Control Group

Ref.	Tennant Part No.	Machine Serial Number	Description	Qty.
1	04761	(030000–030082)	Bearing, Flange	2
2	04762	(030000–)	Spring, Torsion Centering	1
3	04763	(030000–)	Hub and Gear	1
4	04766	(030000–)	Collar, Shaft	1
5	27974	(030083–)	Gear	1
6	27957	(030083–)	Potentiometer Replacement Kit	1
7	04760	(030000–)	Handle, Speed Control	1
8	06208	(030000–)	Washer	2
9	04765	(030000–)	Grip, Handle	2
10	27934	(030083–)	Bracket, Handle	1
11	05611	(030000–)	Isolator, Vibration	2
12	63846	(030000–)	Switch, Push Button	2
13	86730	(030000–)	Nut, Hex, Thin	2
14	04767	(030000–)	Stop, Spring	1
15	27972	(030000–030082)	Potentiometer Replacement Kit	1
16	05582	(030000–030082)	Bearing, Flange	2
17	27973	(030083–)	Bracket, Potentiometer	1
18	27937	(030083–)	Bearing, Flange	2
19	55248	(030000–)	Mount, Cable Tie	1
20	49266	(030000–)	Tie, Cable	1
21	86730	(030083–)	Nut, Hex, Thin	1
22	82226	(030000–)	Washer	1

Fig. 19 – Rear Electrical Panel Group

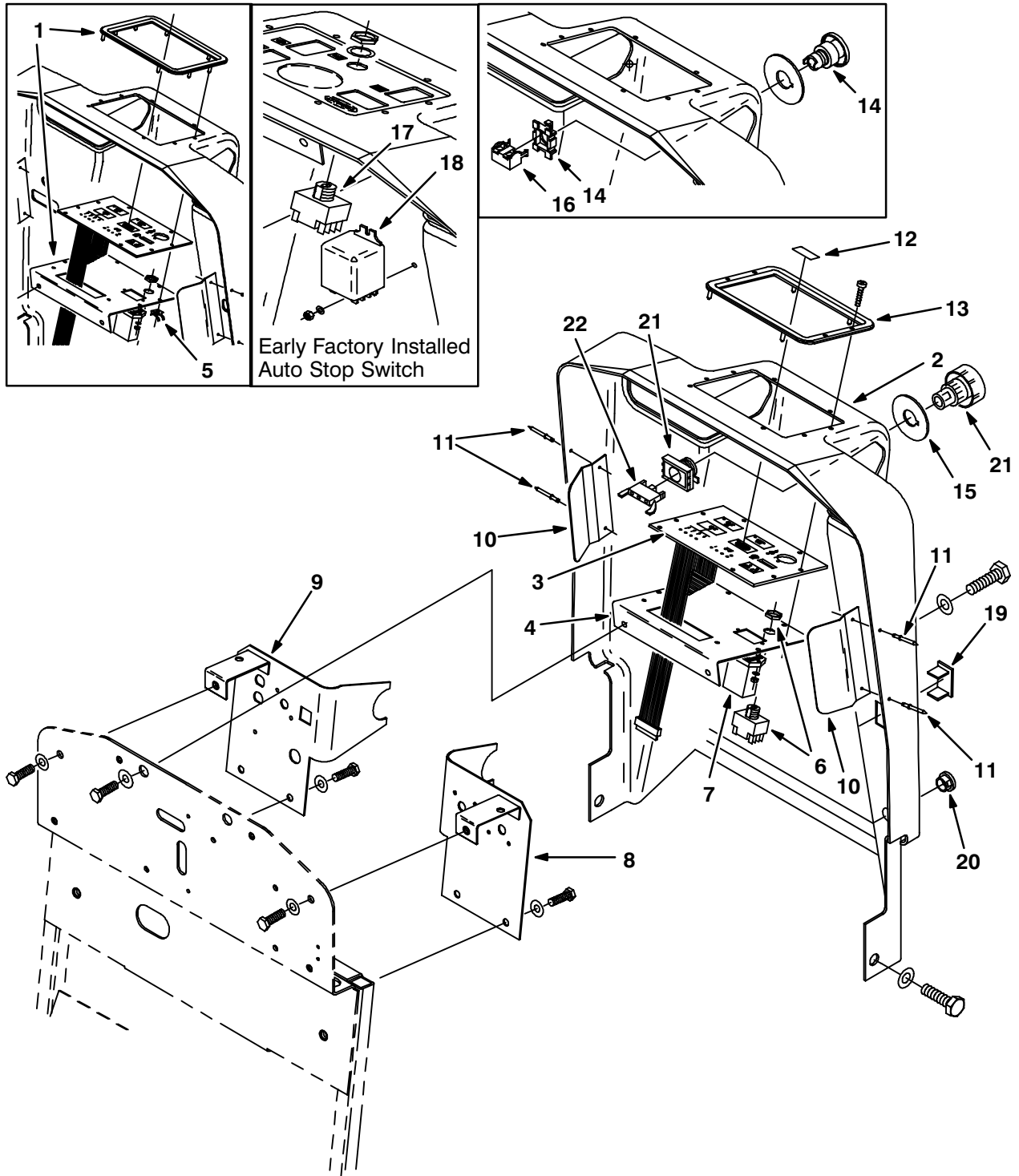
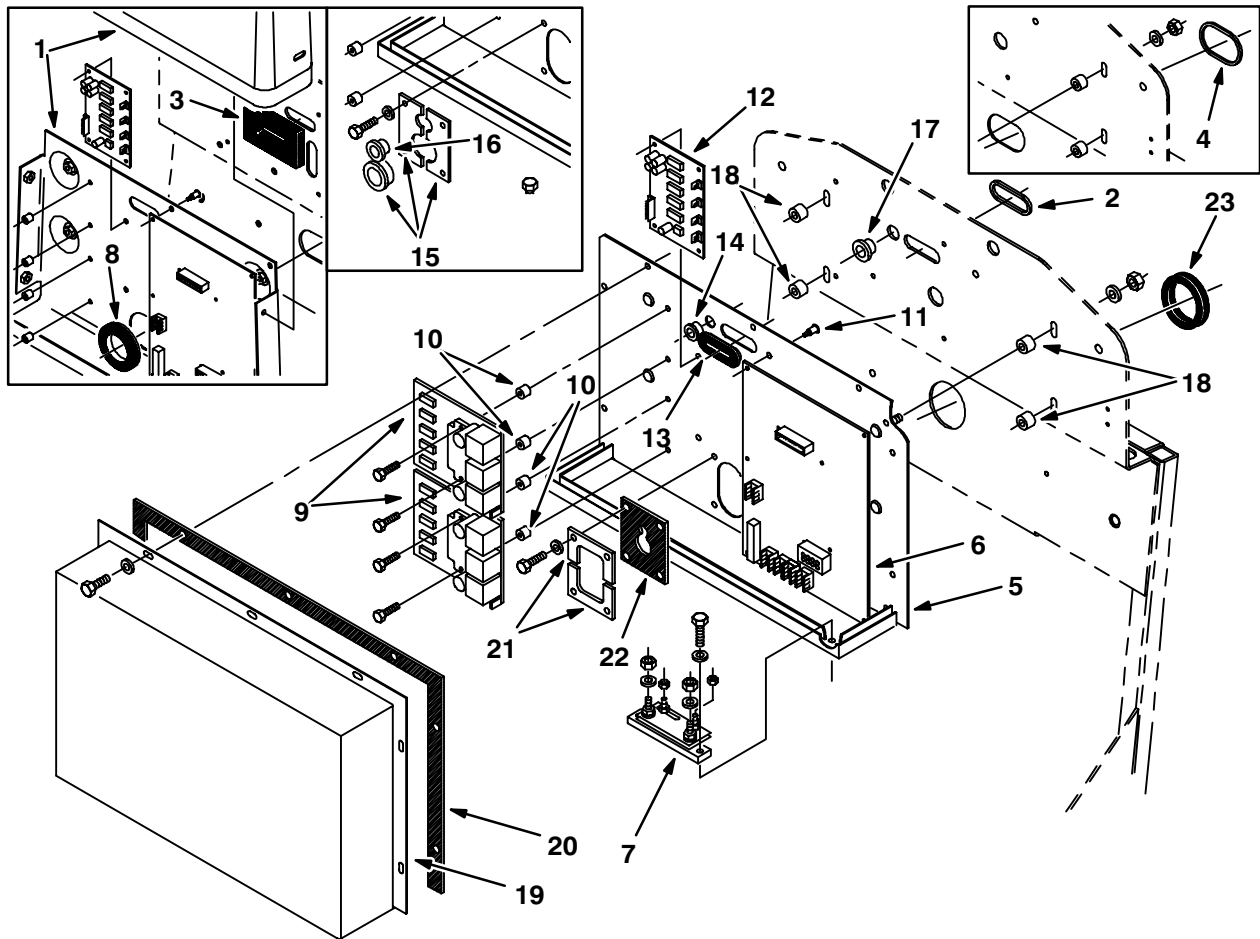

Fig. 19 – Rear Electrical Panel Group

Ref.	Tennant Part No.	Machine Serial Number	Description	Qty.	
1	33408	(030000–030170)	Instrument Panel and Bezel Kit	1	
2	65597	(030000–)	Panel and Label Assembly, Rear	1	
3	65565	(030000–)	Panel, Touch Switch	1	
4	33470	(030171–)	Bracket, Touch Panel	1	
5	05280	(030000–030170)	Clip, Stud	8	
▽	6	31203	(030000–)	Switch Assembly, Key	1
▲		31204	(030000–)	Key, Switch	1
	7	31988	(030000–)	Hourmeter	1
	8	04957	(030000–)	Plate, Circuit Breaker Mounting	1
	9	28416	(030000–)	Plate, Circuit Breaker Mounting	1
	10	05027	(030000–)	Guide, Cover, Rear	2
	11	56799	(030000–)	Rivet, Pop	4
	12	11744	(030000–)	Label, ES™ Cover	1
	13	33492	(030171–)	Bezel, Touch Panel	1
	14	28429	(030000–030329)	Switch, Push Button	1
	15	28428	(030000–)	Plate, Stop Button	1
	16	11608	(030000–030329)	Contacts, Switch	1
▽	17	11651	(030000–030169)	Switch Assembly	1
▲		31204	(030000–030169)	Key, Switch	1
	18	87284	(030000–030169)	Relay, DPDT	1
	19	57772	(030000–)	Plate, Cover	1
	20	65584	(030000–)	Plugbutton	1
	21	65664	(030330–)	Switch, Push Button	1
	22	65665	(030330–)	Contacts, Switch	1

Fig. 20 – Electrical Controller Group



05071/04777

Ref.	Tennant Part No.	Machine Serial Number	Description	Qty.
1	27950	(030000–030077)	Cover and Panel Replacement Kit	1
2	11708	(030000–)	Grommet, Flexible	1
3	06126	(030000–030077)	Seal, Electrical Panel (Replaced by 27928)	1
4	11707	(030000–030238)	Grommet, Flexible	1
5	27941	(030078–)	Panel, Electric	1
6	27960	(030000–)	Control Board Kit	1
7	10973	(030000–)	Shunt	1
8	56390	(030000–030077)	Grommet	1
9	27961	(030000–)	Controller Kit, Dual	2
10	65742	(030000–)	Sleeve	4
11	15840	(030000–)	Pin, Prong	14
12	27962	(030000–)	Board Kit, Interface Steering	1
13	27928	(030078–)	Grommet, Ribbon Cable	1
14	27947	(030078–)	Grommet	1
15	28341	(030078–030181)	Grommet Replacement Kit	2
16	27948	(030078–030181)	Grommet	1
17	27948	(030078–)	Grommet	1
18	40282	(030078–)	Sleeve	4
19	27951	(030078–)	Cover and Label Kit, Electric Panel	1
20	27945	(030078–)	Gasket, Electric Panel	1
21	27914	(030182–)	Plate, Harness	2
22	27915	(030182–)	Grommet, Harness	1
23	10632–19	(030239–)	Grommet	1

Fig. 21 – Rear Electrical Group

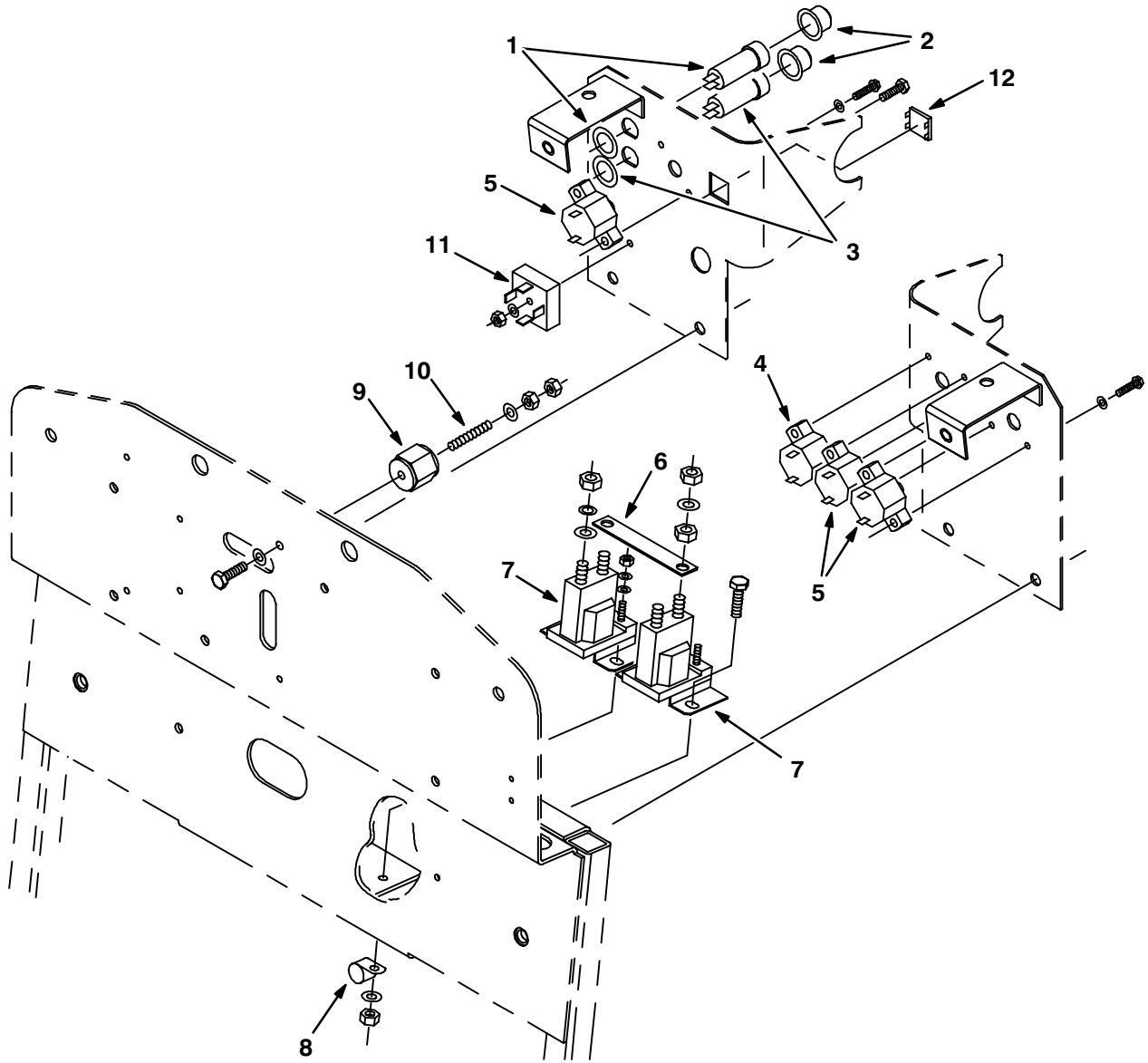

05073/04776

Ref.	Tenant Part No.	Machine Serial Number	Description	Qty.
1	27920	(030000–)	Breaker, Circuit, 5 A	1
2	57751	(030000–)	Boot, Circuit Breaker	2
3	57164	(030000–)	Breaker, Circuit, 10 A	1
4	27967	(030000–)	Breaker, Circuit, 20 A	1
5	63030–2	(030000–)	Breaker, Circuit, 25 A	3
6	10967	(030000–)	Busbar, Relay	1
7	04685	(030000–)	Contactors	2
8	26395–1	(030000–)	Clamp, Cable	1
9	76062	(030000–)	Insulator, Panel and Switchboard	1
10	41702	(030000–)	Rod, Threaded	1
11	10962	(030000–)	Diode, Bridge, 12 A	1
12	28426	(030172–)	Plugbutton	1

Fig. 22 – Rear Squeegee Link Group

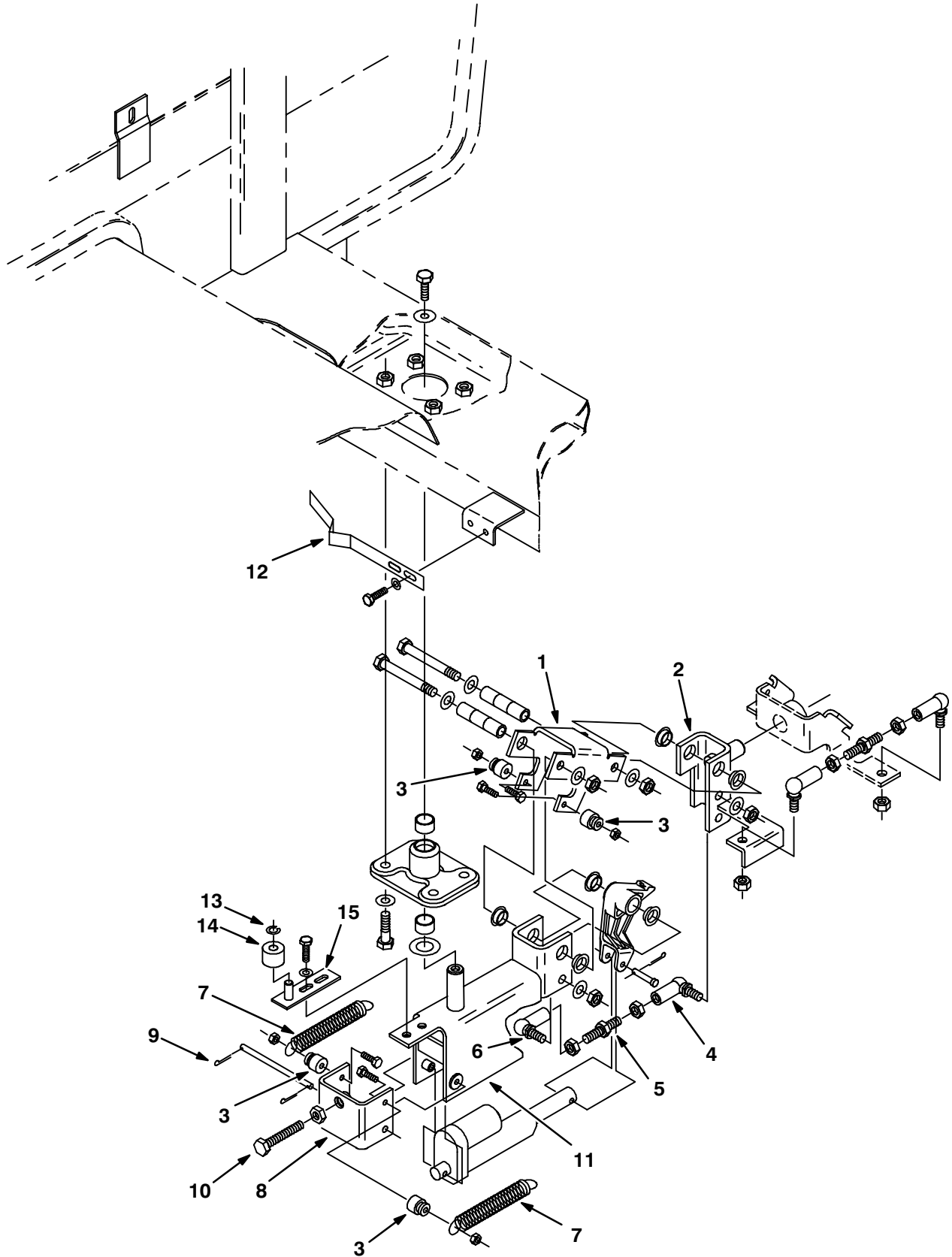

Fig. 22 – Rear Squeegee Link Group

Ref.	Tennant Part No.	Machine Serial Number	Description	Qty.
1	04853	(030000-030064)	Bracket, Squeegee Lift	1
2	04849	(030000-030064)	Bracket, Squeegee Lift	1
3	05120	(030000-030064)	Retainer, Spring	4
4	05291	(030000-030064)	Rod End, M10, L.H.	1
5	04869	(030000-030064)	Stud, Adjustment	1
6	05290	(030000-030064)	Rod End, M10, R.H.	1
7	04854	(030000-030064)	Spring, Tension	2
8	05678	(030000-030064)	Bracket, Spring Adjustment	1
19	05282	(030000-030064)	Pin, Actuator Mount	1
10	06419	(030000-030064)	Bolt, Adjustment	1
11	04856	(030000-030064)	Bracket, Squeegee Pivot (replaced by 33398)	1
12	63212	(030000-030135)	Spring, Squeegee Centering	1
13	23514-1	(030000-030135)	Ring, Retaining	1
14	63878	(030000-030135)	Roller	1
15	11679	(030000-030135)	Bracket, Roller	1

Fig. 23 – Rear Squeegee Link Group

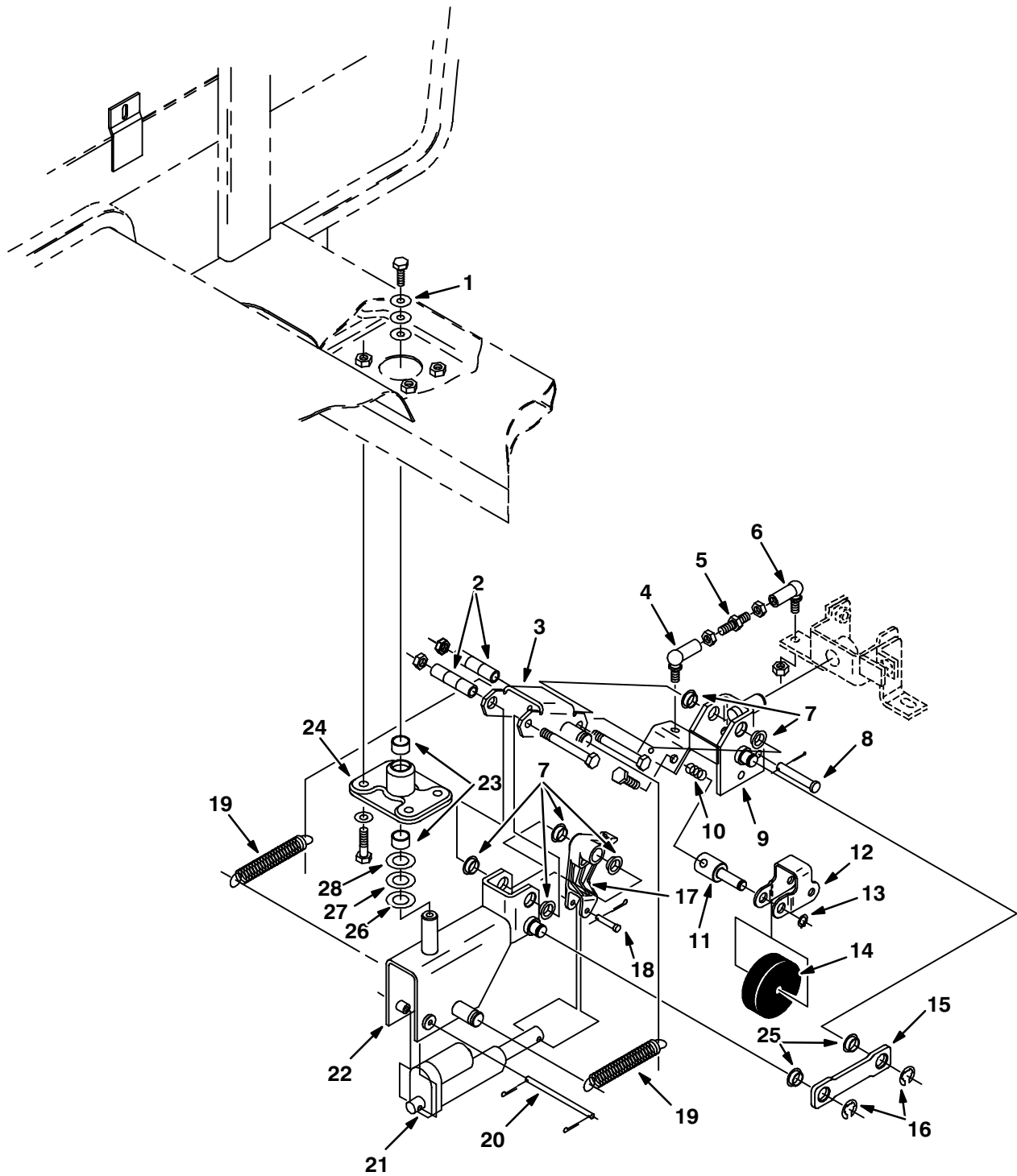

Fig. 23 – Rear Squeegee Link Group

Ref.	Tennant Part No.	Machine Serial Number	Description	Qty.
1	05624	(030000–) Washer	1
2	05145	(030000–) Sleeve, Squeegee Lift	2
3	33362	(030065–) Bracket, Squeegee Lift	1
4	82962	(030000–) Ball Joint, L.H.	1
5	11676	(030000–) Stud, Adjustment	1
6	63282	(030000–) Ball Joint, R.H.	1
7	04843	(030000–) Bearing, Flange	6
8	33355	(030065–) Pin, Clevis	1
9	33348	(030065–) Bracket, Squeegee Lift	1
10	33498	(030065–) Spring	1
11	33379	(030065–) Axle, Caster Adjustment	1
12	33499	(030065–) Bracket, Caster	1
13	05284	(030065–) Clip, Retainer	1
14	86800	(030065–) Wheel	1
15	33371	(030065–) Link, Connecting	1
16	33373	(030065–) Ring, Retaining	2
17	04845	(030000–) Arm, Lift	1
18	05283	(030000–) Pin, Clevis	1
19	33395	(030065–) Spring, Tension	2
20	33391	(030065–) Pin, Actuator	1
21	48679	(030000–) Actuator	1
22	33388	(030065–) Bracket, Pivot, Squeegee	1
23	64377	(030000–) Bearing, Journal	2
24	05099	(030000–) Flange, Squeegee	1
25	04843	(030065–) Bearing, Flange	2
26	64489	(030065–) Washer	1
27	40847–1	(030000–) Shim	–
28	04846	(030000–) Washer, Thrust	1

Fig. 24 – Rear Squeegee Group

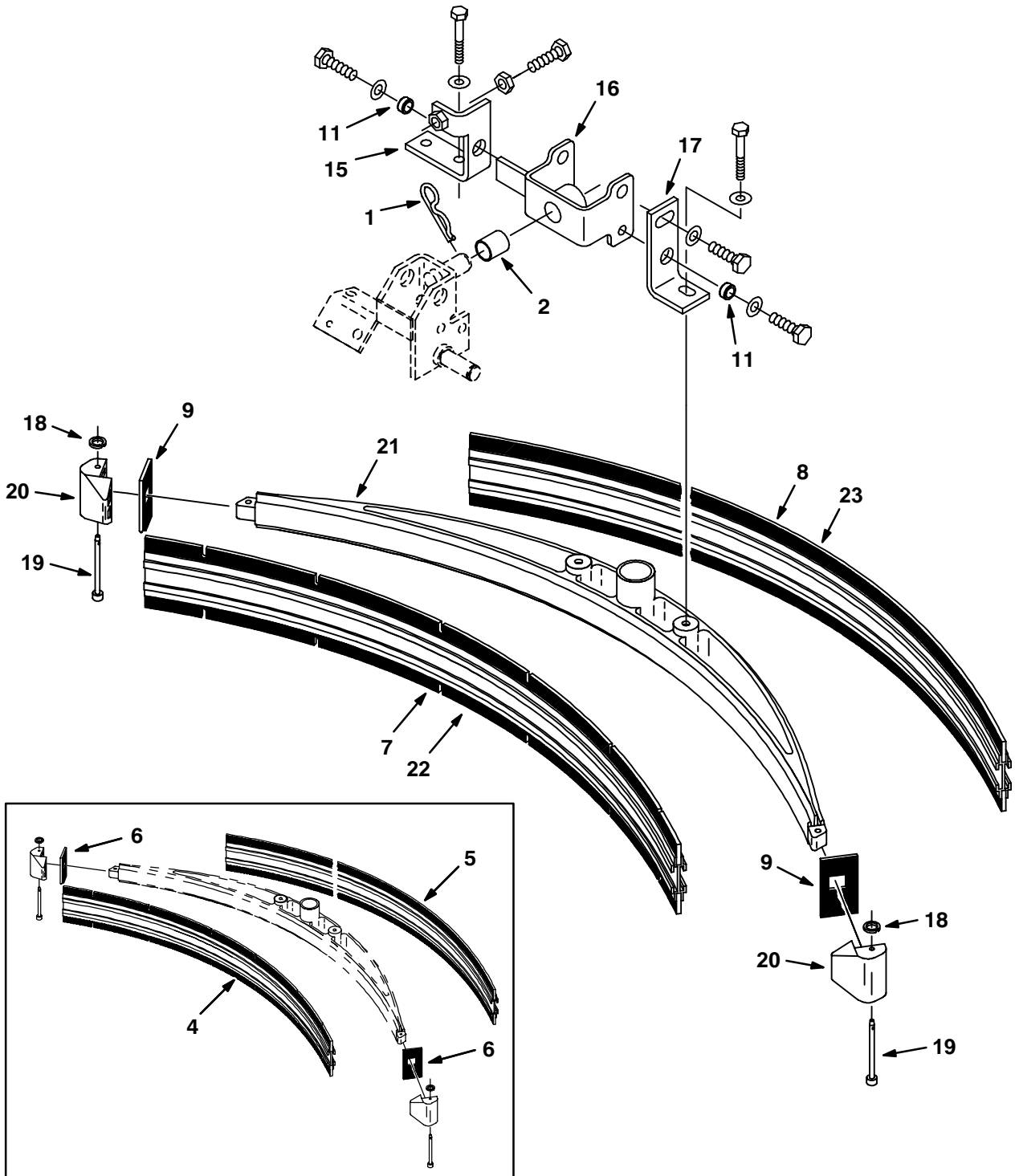
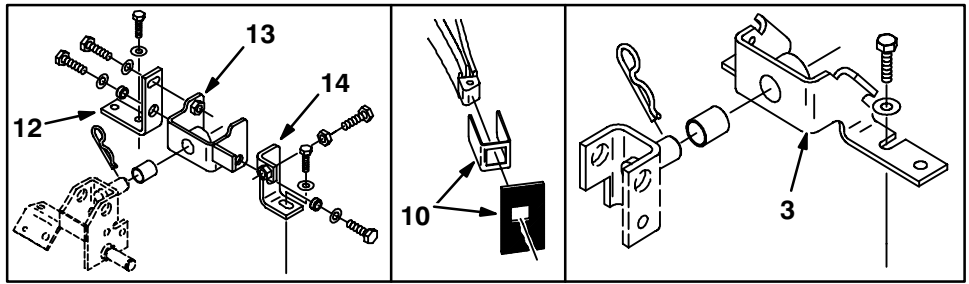
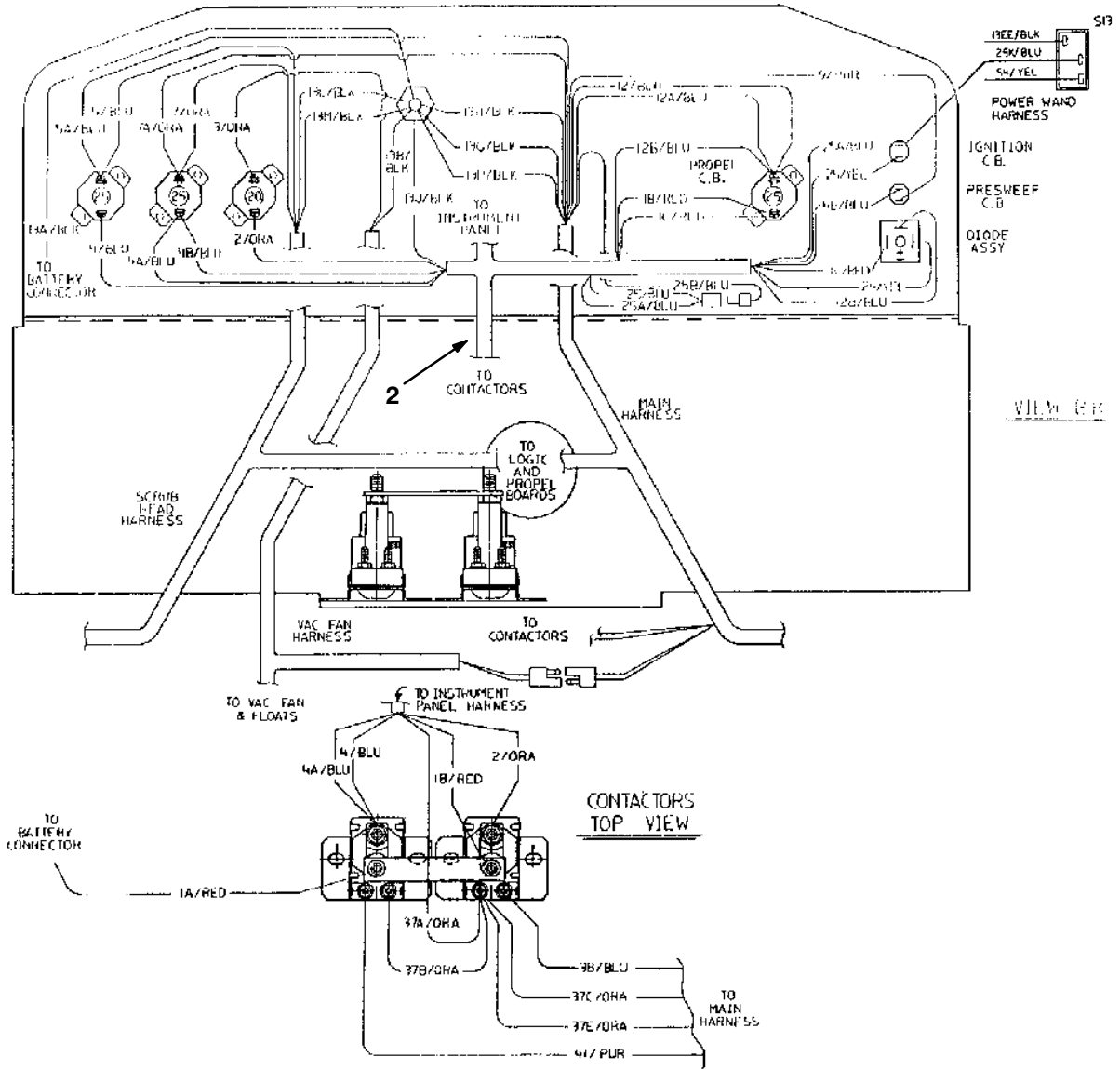

Fig. 24 – Rear Squeegee Group

Ref.	Tennant Part No.	Machine Serial Number	Description	Qty.
1	55094	(030000–)	Pin, Hair Cotter	1
2	04844	(030000–)	Bearing, Journal	1
3	04852	(030000–030064)	Bracket, Squeegee Pivot	1
▽	11484	(030000–030155)	Squeegee Blade Kit, Short	1
▲	4	04894	(030000–030155) Squeegee Blade Assembly, Front	1
▲	5	04898	(030000–030155) Squeegee Blade Assembly, Rear	1
▲	6	33437	(030000–030155) Blade, Squeegee End	2
▽	24686	(030156–)	Squeegee Blade Kit, Long	1
▲	7	33357	(030156–) Squeegee Blade Assembly, Front	1
▲	8	33352	(030156–) Squeegee Blade Assembly, Rear	1
▲	9	11283	(030156–) Blade, Squeegee End	2
10	27952	(030000–030123)	Squeegee End Replacement Kit (For both sides)	1
11	33369	(030065–)	Sleeve, Squeegee	2
12	33378	(030065–030177)	Bracket, Adjuster, R.H.	1
13	33376	(030065–030177)	Bracket, Squeegee Pivot	1
14	33377	(030065–030177)	Bracket, Adjuster, L.H.	1
15	04819	(030178–)	Bracket, Adjuster, R.H.	1
16	04809	(030178–)	Bracket, Squeegee Pivot	1
17	04808	(030178–)	Bracket, Adjuster, L.H.	1
18	49708	(030000–)	Ring, Split	2
19	33403	(030000–)	Pin, Clevis	2
20	04752	(030000–)	Bumper, Squeegee	2
21	24589	(030000–)	Body, Squeegee	1
22	78544	(030156–)	Squeegee Blade Assembly, Front, Urethane	1
23	78545	(030156–)	Squeegee Blade Assembly, Rear, Urethane	1

Fig. 25 – Wire Harness Group



05213/05212

Ref.	Tennant Part No.	Machine Serial Number	Description	Qty.
1	27958	(030000–030025)	Harness Kit, Wire, Main	1
1	28611	(030026–030174)	Harness Kit, Wire, Main	1
1	28610	(030175–)	Harness, Wire, Main	1
2	05638	(030000–)	Harness, Instrument Panel	1
3	28350	(030000–030118)	Harness Replacement Kit, Vacuum Fan	1
3	28347	(030119–)	Harness, Wire, Vacuum Fan	1
4	05639	(030000–)	Harness, Wire, Scrub Head	1
5	04691	(030000–)	Harness, Wire, Logic	1
6	05633	(030000–)	Harness, Wire, Power Steering	1
7	04693	(030000–)	Harness, Wire, Steering Switch	1
8	65697	(030170–)	Harness, Wire, Switch	1

Fig. 26 – Label Group

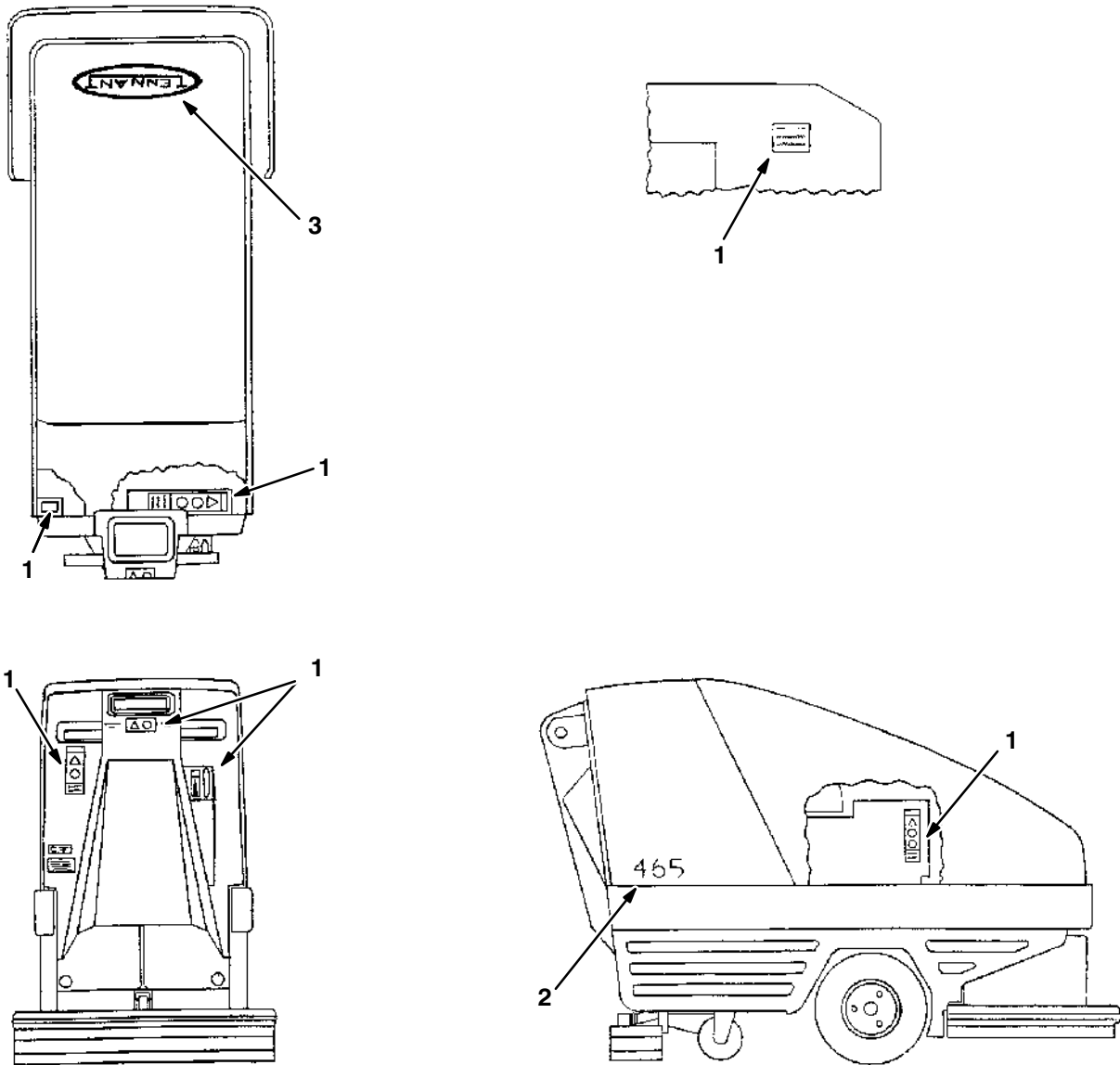

05101/05098

Ref.	Tennant Part No.	Machine Serial Number	Description	Qty.
1	11541	(030000–)	Label Set, Information and Hazard	1
2	11662	(030000–)	Label, Numerals 1465	2
3	86877	(030000–)	Label, TENNANT Logo, White	1

SECTION 7

CONTENTS

	Page
Fig. 1 – Recommended General Maintenance Items	7-2
Fig. 2 – Replacement Brushes	7-3
Fig. 3 – Hood and Bumper Group	7-4
Fig. 4 – Hood and Bumper Group	7-6
Fig. 5 – Main Frame Group	7-8
Fig. 6 – Main Frame Group	7-9
Fig. 7 – Side Skirt Support Group	7-10
Fig. 8 – Front Shroud Group	7-12
Fig. 9 – Scrub Head Lift Group	7-14
Fig. 10 – Scrub Head Group	7-16
Fig. 11 – Tire and Rim Assembly	7-17
Fig. 12 – Dual Drive Group	7-18
Fig. 13 – Solution And Recovery Tanks Group	7-20
Fig. 14 – Recovery Tank Float Group	7-22
Fig. 15 – Solution Control Group	7-24
Fig. 16 – Battery Group	7-26
Fig. 17 – Battery Group	7-28
Fig. 18 – Steering Control Group	7-30
Fig. 19 – Rear Electrical Panel Group	7-32
Fig. 20 – Electrical Controller Group	7-34
Fig. 21 – Rear Electrical Group	7-35
Fig. 23 – Rear Squeegee Link Group	7-38
Fig. 24 – Rear Squeegee Group	7-40
Fig. 25 – Wire Harness Group	7-42
Fig. 26 – Label Group	7-44

Fig. 1 – Recommended General Maintenance Items

Ref.	Tennant Part No.	Machine Serial Number	Description	Qty.
▽	11485	(040000–040385)	Squeegee Blade Kit, Short	1
▲	04916	(040000–040385)	Squeegee Blade Assembly, Front	1
▲	04919	(040000–040385)	Squeegee Blade Assembly, Rear	1
▲	33437	(040000–040385)	Blade, Squeegee End	2
▽	24687	(040386–)	Squeegee Blade Kit, Long	1
▲	33424	(040386–)	Squeegee Blade Assembly, Front	1
▲	33354	(040386–)	Squeegee Blade Assembly, Rear	1
▲	11283	(040386–)	Blade, Squeegee End	2
	78546	(040386–)	Squeegee Blade Assembly, Front, Urethane	1
	78547	(040386–)	Squeegee Blade Assembly, Rear, Urethane	1

Fig. 2 – Replacement Brushes

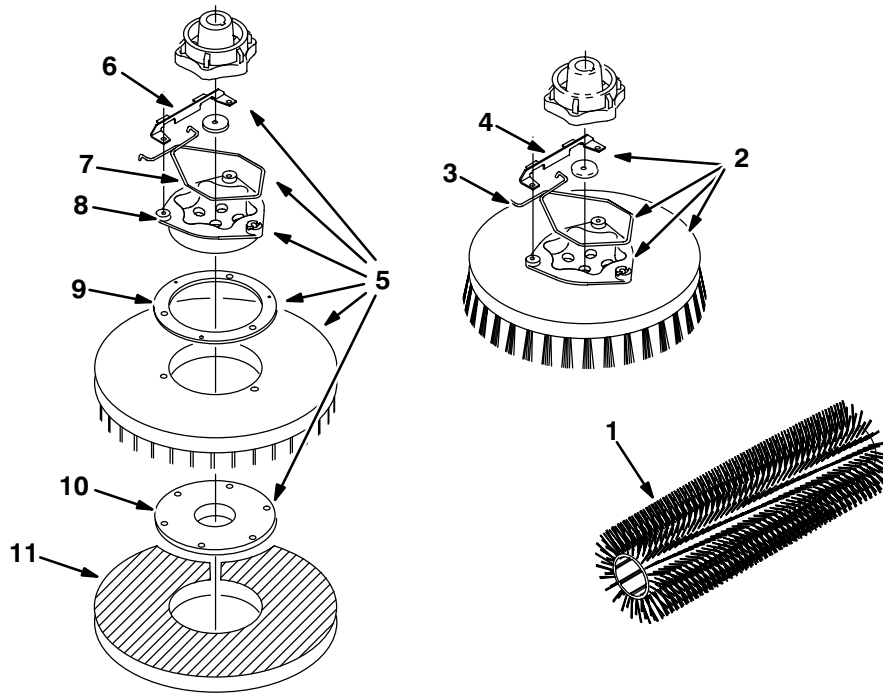

05104/05105

Ref.	Tennant Part No.	Machine Serial Number	Description	Qty.
1	11682	(000000-)	Brush, Pre-Sweep, Polypropylene	1
▽	2	05725	(000000-) Scrub Brush Assembly, Stiff Polypropylene	2
▲	3	14838	(000000-) Spring, Brush Retaining	1
▲	4	24299	(000000-) Bracket, Spring Retainer	1
▽	30241	(000000-) Scrub Brush Assembly, Polypropylene	2	
▲	14838	(000000-) Spring, Brush, Retaining	1	
▲	24299	(000000-) Bracket, Spring, Retainer	1	
▽	05724	(000000-) Scrub Brush Assembly, Nylon	2	
▲	14838	(000000-) Spring, Brush Retaining	1	
▲	24299	(000000-) Bracket, Spring Retainer	1	
▽	05726	(000000-) Scrub Brush Assembly, Abrasive	2	
▲	14838	(000000-) Spring, Brush Retaining	1	
▲	24299	(000000-) Bracket, Spring Retainer	1	
▽	05036	(000000-) Scrub Brush Assembly, Bassine	1	
▲	14838	(000000-) Spring, Brush Retainer	1	
▲	24299	(000000-) Bracket, Spring Retainer	1	
▽	05038	(000000-) Scrub Brush Assembly, Wire	2	
▲	14838	(000000-) Spring, Brush Retainer	1	
▲	24299	(000000-) Bracket, Spring Retainer	1	
▽	5	30216	(000000-) Scrub Driver Pad Assembly, Polypropylene	2
▲	6	24299	(000000-) Bracket, Retainer Spring	1
▲	7	14838	(000000-) Spring, Brush Retaining	1
▲	8	15539	(000000-) Adaptor, Brush	1
▲	9	11218	(000000-) Spacer, Pad Holder	1
▲	10	19783	(000000-) Holder, Pad	1
	11	63248-1	(000000-) Pad, Stripper, Brown	2
		63248-2	(000000-) Pad, Scrubber, Blue	2
		63248-3	(000000-) Pad, Buffer, Red	2
		63248-4	(000000-) Pad, Polish, White	2

Fig. 3 – Hood and Bumper Group

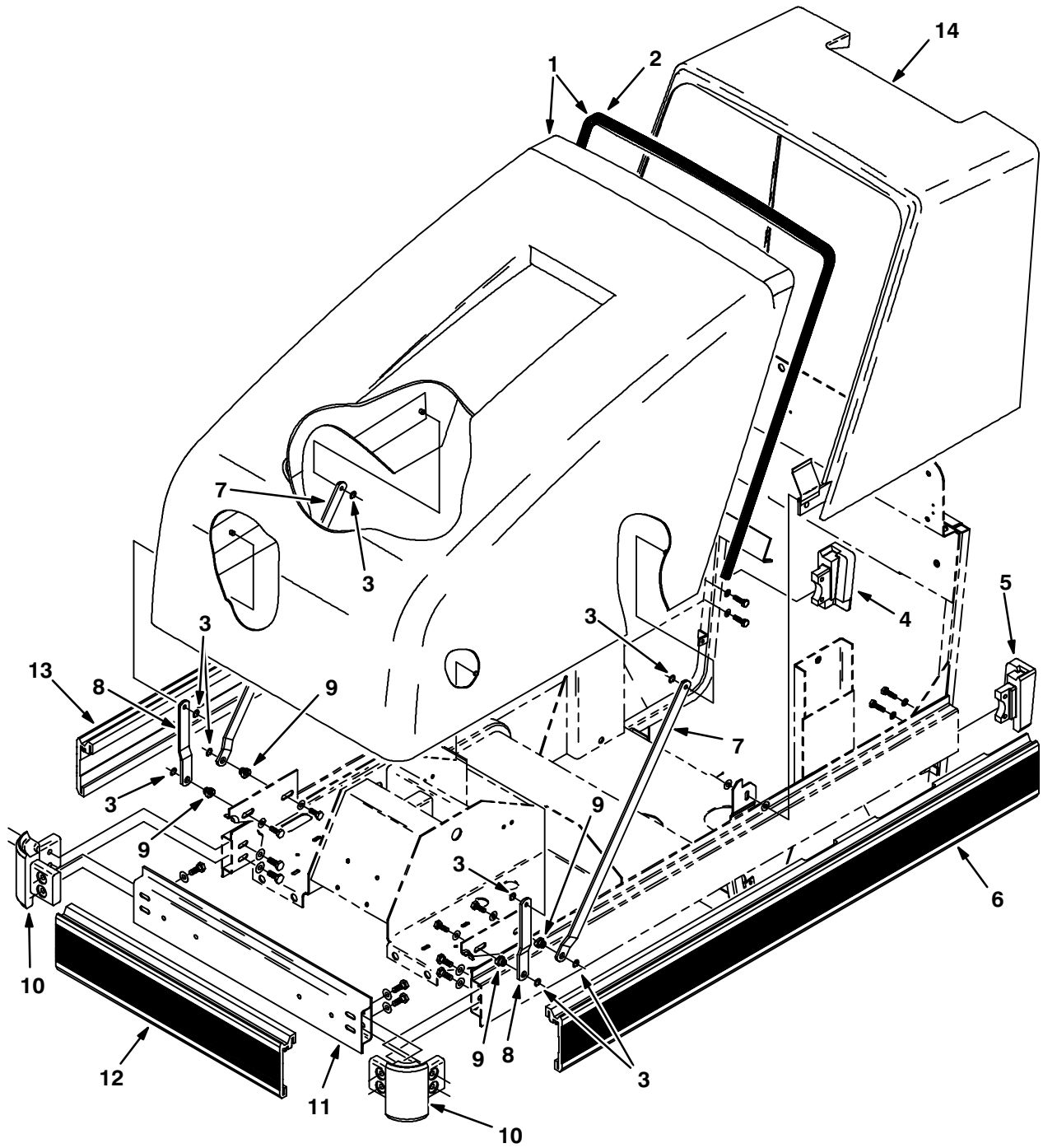

Fig. 3 – Hood and Bumper Group

	Ref.	Tennant Part No.	Machine Serial Number	Description	Qty.
▽	1	05574	(040000-040469)	Cover, Front	1
▲	2	33360	(040000-040469)	Seal	1
	3	05284	(040000-040469)	Clip, Retainer,M10	8
	4	10987	(040000-040469)	Corner Block, Frame, R.H.	1
	5	10988	(040000-040469)	Corner Block, Frame, L.H.	1
	6	05070	(040000-040469)	Bumper, Side, L.H.	1
	7	05236	(040000-040469)	Bar, Long Hinge	2
	8	05223	(040000-040469)	Bar, Short Hinge	2
	9	05272	(040000-040469)	Spacer, Hinge	4
	10	04945	(040000-040469)	Corner Frame Block Assembly	2
	11	04944	(040000-040469)	Channel, Frame	1
	12	05073	(040000-040469)	Bumper, Front	1
	13	05276	(040000-040469)	Bumper, Side, R.H.	1
	14	05573	(040000-040469)	Cover, Rear	1

Fig. 4 – Hood and Bumper Group

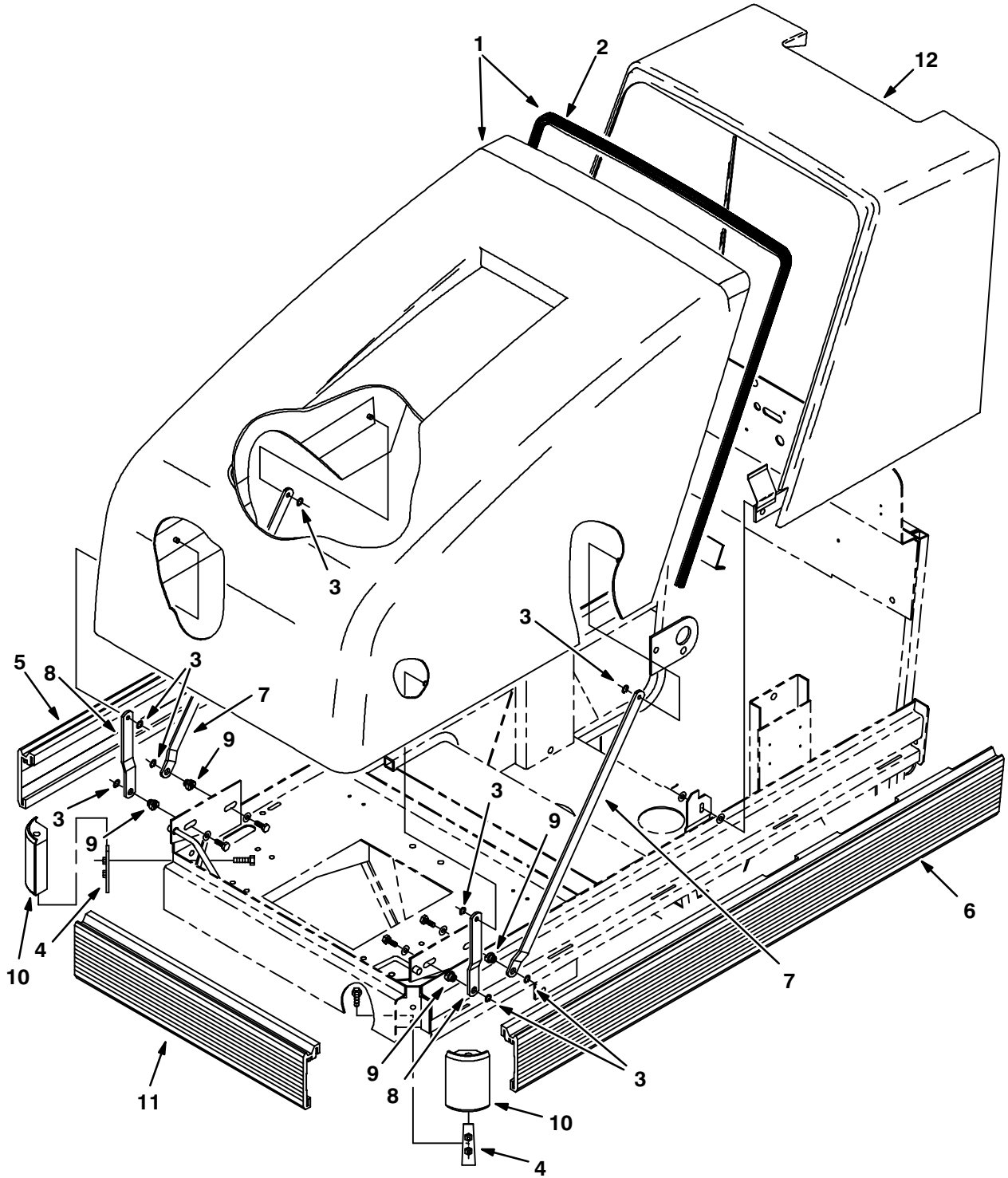
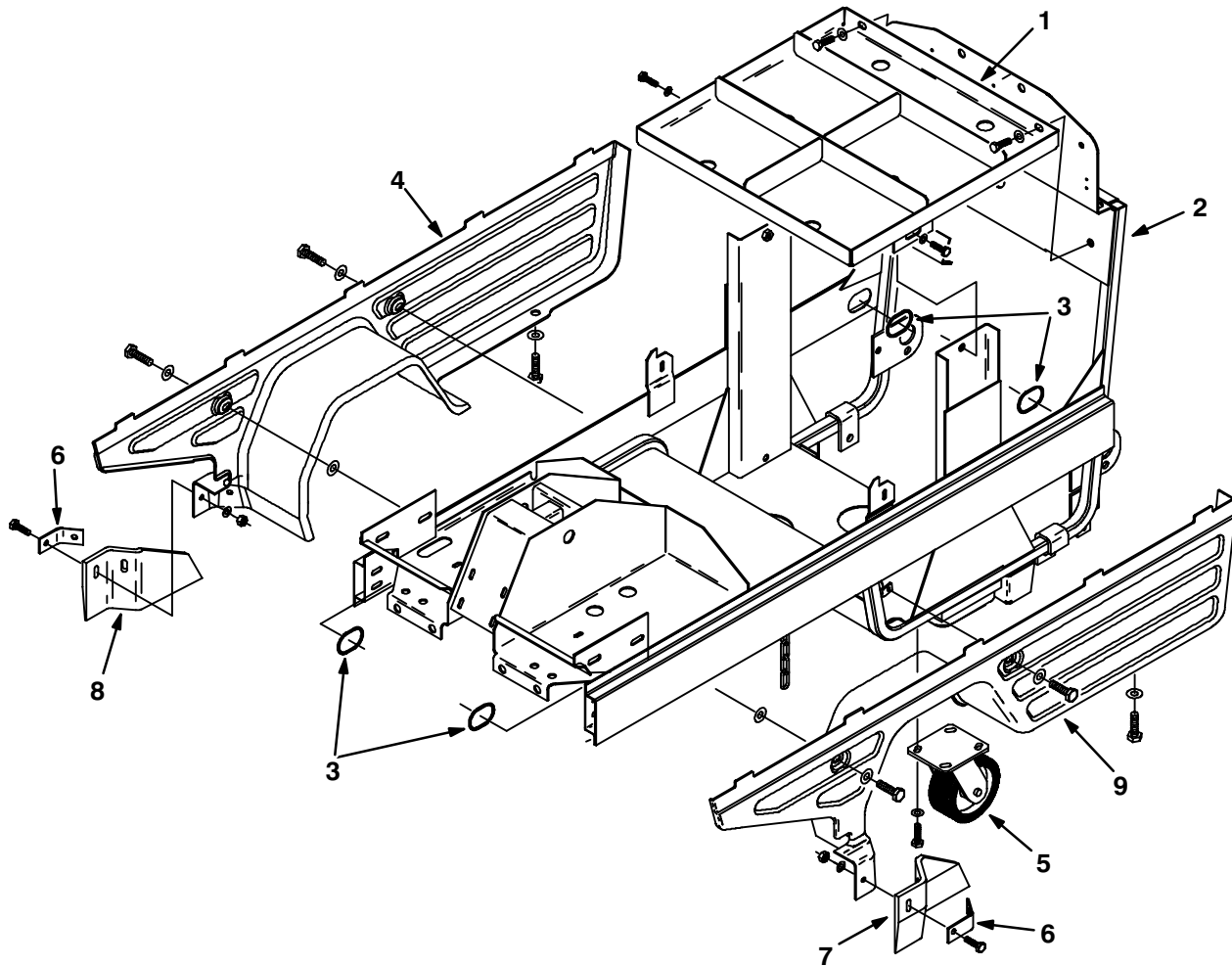

Fig. 4 – Hood and Bumper Group

	Ref.	Tennant Part No.	Machine Serial Number	Description	Qty.
▽	1	05574	(040470–)	Cover, Front	1
▲	2	33360	(040470–)	Seal	1
	3	05284	(040470–)	Clip, Retainer	8
	4	33454	(040470–)	Plate, Mount	2
	5	33537	(040470–)	Bumber, Side, R.H.	1
	6	33536	(040470–)	Bumper, Side, L.H.	1
	7	05236	(040470–)	Bar, Hinge Long	2
	8	05223	(040470–)	Bar, Hinge Short	2
	9	05272	(040470–)	Spacer, Hinge	4
	10	33407	(040470–)	Block, Corner Frame	2
	11	05073	(040470–)	Bumper, Front	1
	12	05573	(040470–)	Cover, Rear	1

Fig. 5 – Main Frame Group



05058/04775

Ref.	Tennant Part No.	Machine Serial Number	Description	Qty.
1	28163	(040000-040469)	Tray, Battery	1
2	24865	(040000-040469)	Frame Replacement Kit	1
3	27929	(040000-040469)	Grommet	4
4	05046	(040000-040469)	Panel, Lower, R.H.	1
5	65690	(040000-040469)	Caster	2
6	10934	(040000-040469)	Strip, Skirt Retainer	2
7	10932	(040000-040469)	Skirt, Lower, Panel, L.H.	1
8	10933	(040000-040469)	Skirt, Lower, Panel, R.H.	1
9	05045	(040000-040469)	Panel, Lower, L.H.	1

Fig. 6 – Main Frame Group

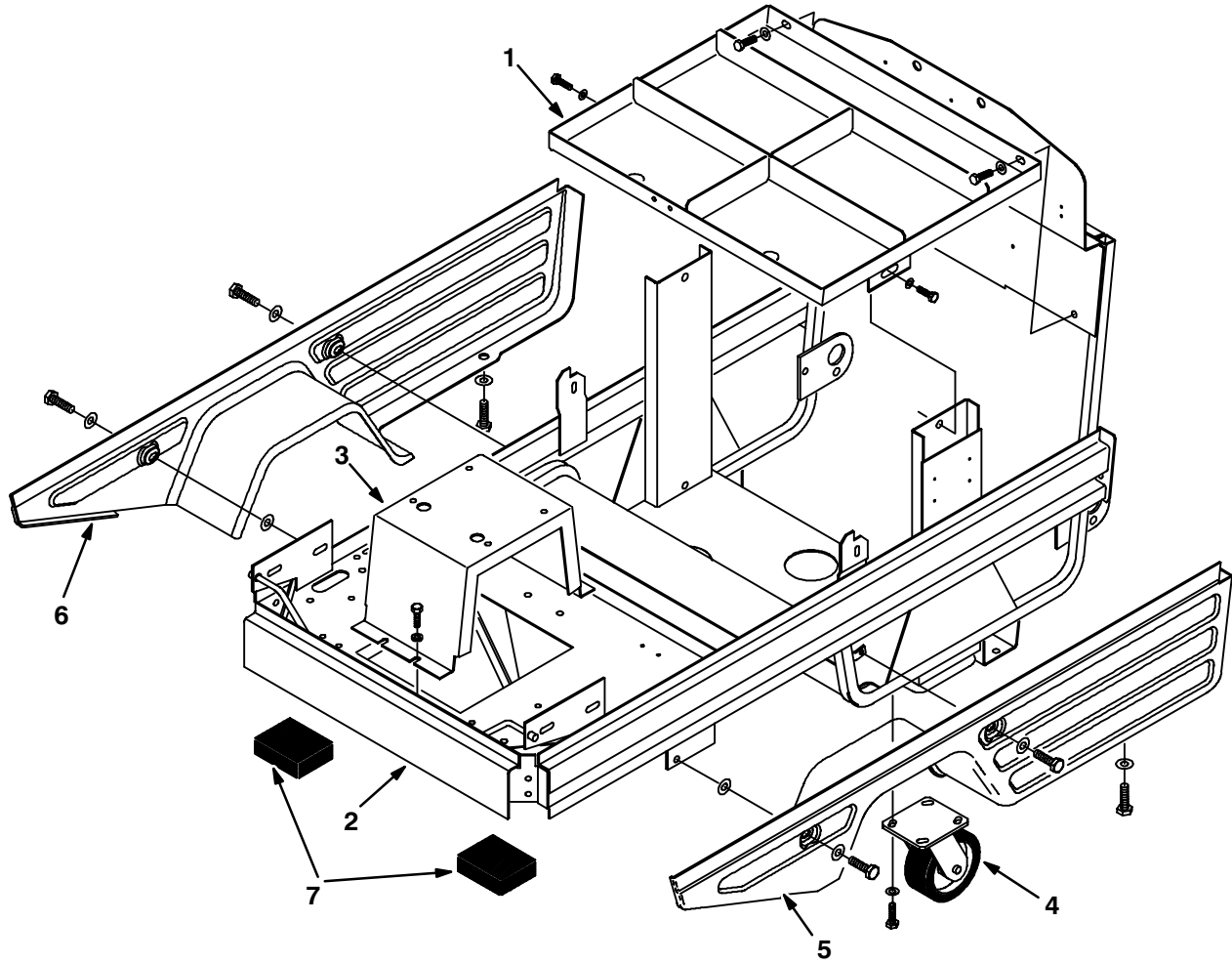

06173/06983

Ref.	Tennant Part No.	Machine Serial Number	Description	Qty.
1	28163	(040470–)	Tray, Battery	1
2	33419	(040470–)	Frame, Main	1
3	33416	(040470–)	Channel	1
4	65690	(040470–)	Caster	2
5	24931	(040470–)	Panel, Cover, L.H.	1
6	24932	(040470–)	Panel, Lower, R.H.	1
7	04702	(040470–)	Pad, Head Stop	2

Fig. 7 – Side Skirt Support Group

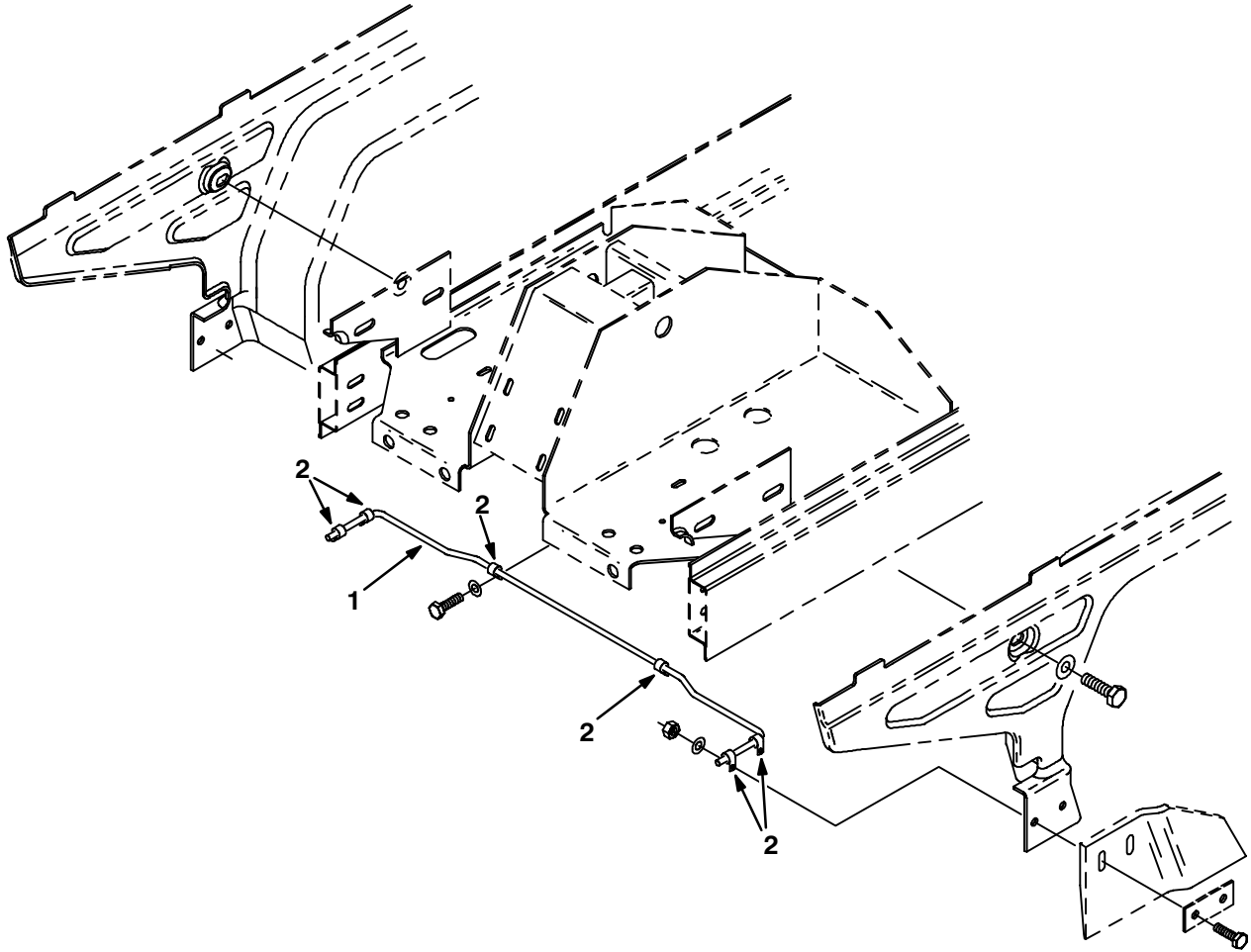

Fig. 7 – Side Skirt Support Group

Ref.	Tennant Part No.	Machine Serial Number	Description	Qty.
1	05681	(040000–040469)	Spring, Skirt Mounting	1
2	46236	(040000–040469)	Clamp, Cable	6

Fig. 8 – Front Shroud Group

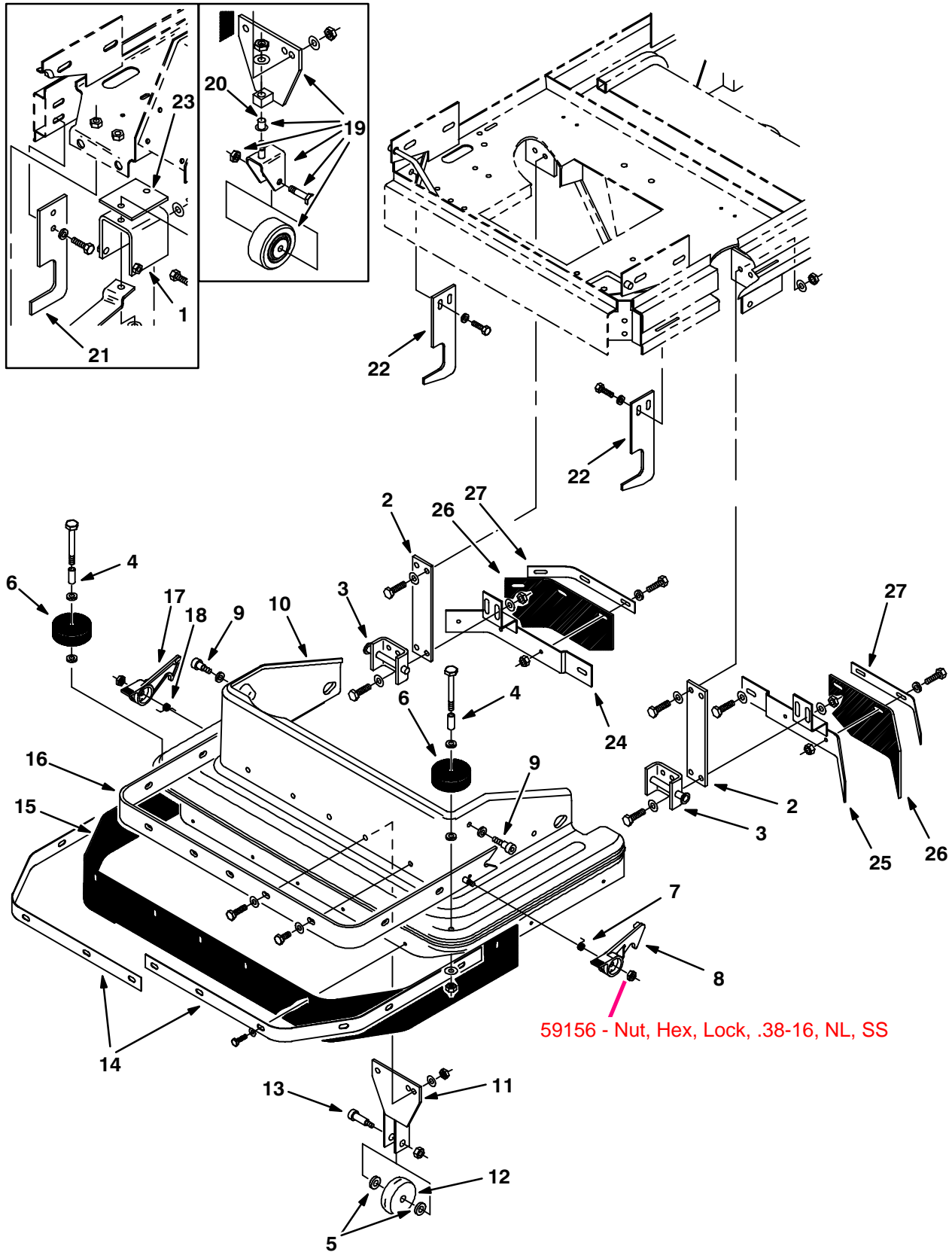

Fig. 8 – Front Shroud Group

Ref.	Tennant Part No.	Machine Serial Number	Description	Qty.
1	06103	(040000–040469)	Bracket, Spring Mounting	2
2	06108	(040000–)	Spring	2
3	05214	(040000–)	Bracket, Shroud Mounting	2
▽	28497	(040000–)	Scrub Shroud Replacement Kit	1
▲	4 33427	(040000–)	Sleeve	2
▲	5 59633	(040292–)	Bearing, Fiberglide Thrust	2
▲	6 86800	(040000–)	Wheel	2
▲	7 10927	(040000–)	Spring, Torsion, L.H.	1
▲	8 11613	(040000–)	Latch, Shroud, L.H.	1
▲	9 36758	(040292–)	Screw, Shoulder	2
▲	10 28495	(040000–)	Panel, Shroud Mounting	1
▲	11 28365	(040292–)	Bracket, Wheel	1
▲	12 86800	(040292–)	Wheel	1
▲	13 86791	(040292–)	Screw, Shoulder	1
▲	14 05244	(040000–)	Strip, Skirt Retainer	2
▲	15 05241	(040000–)	Skirt, Scrub Head	1
▲	16 05058	(040000–)	Strap, Shroud	1
▲	17 11612	(040000–)	Latch, Shroud, R.H.	1
▲	18 10928	(040000–)	Spring, Torsion, R.H.	1
19	28360	(040000–040291)	Wheel Replacement Kit	1
20	11489	(040000–040291)	Bearing, Flanged	1
21	28366	(040292–040469)	Plate, Shroud	2
22	24852	(040470–)	Plate, Mount	2
23	28238	(040000–040469)	Plate, Spacer	2
24	33546	(040470–)	Bracket, Skirt, R.H.	1
25	33544	(040470–)	Bracket, Skirt, L.H.	1
26	33566	(040470–)	Skirt, Side	2
27	33553	(040470–)	Strip, Backup	2

Fig. 9 – Scrub Head Lift Group

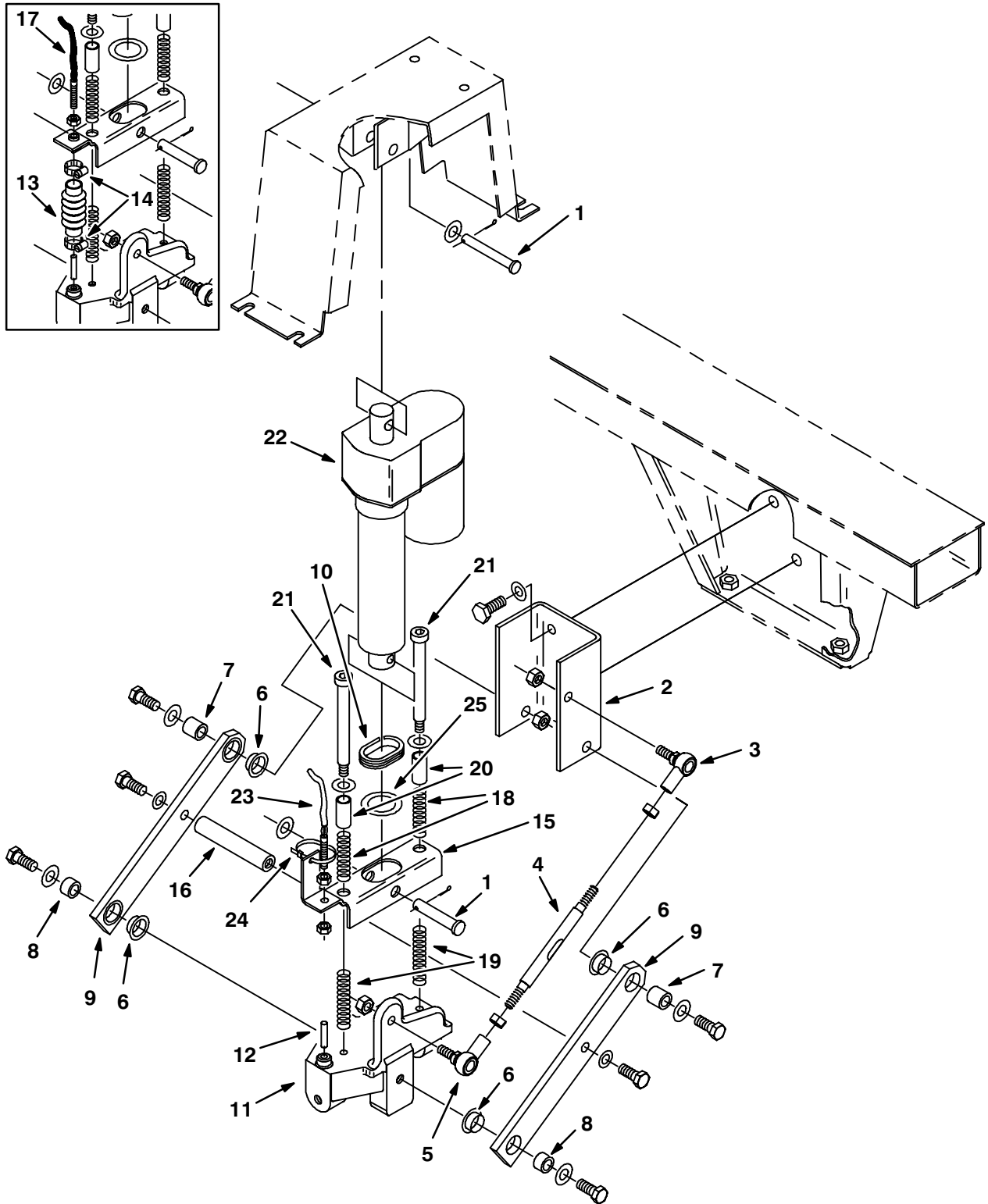
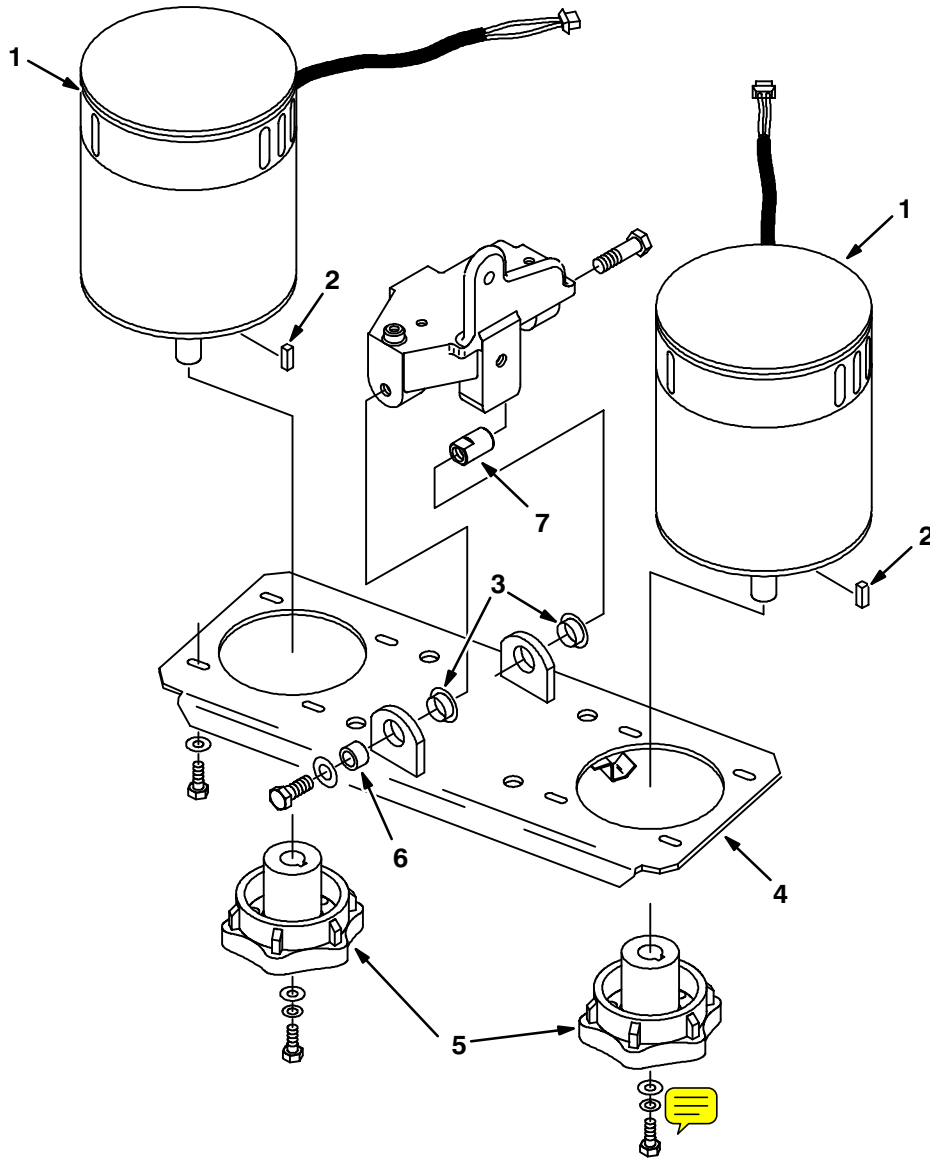

Fig. 9 – Scrub Head Lift Group

Ref.	Tennant Part No.	Machine Serial Number	Description	Qty.
1	51534	(040000–)	Pin, Clevis	2
2	04929	(040000–)	Bracket, Link Mount	1
3	05685	(040000–)	Rod End, M10, L.H.	1
4	04921	(040000–)	Rod, Adjusting	1
5	05686	(040000–)	Rod End, M10, R.H.	1
6	04928	(040000–)	Bearing, Flange	4
7	05019	(040000–)	Sleeve	2
8	04927	(040000–)	Sleeve	2
9	04920	(040000–)	Bar, Pivot	2
10	10632–14	(040000–)	Grommet	1
11	04924	(040000–)	Pivot, Scrub Head	1
12	05735	(040000–)	Magnet, Switch	1
13	54333	(040000–040479)	Clamp, Worm Drive	2
14	05793	(040000–040479)	Boot, Switch (replaced by none)	1
15	28577	(040000–)	Bracket, Head Lift	1
16	04942	(040000–)	Spacer, Rod	1
17	28609	(040000–040479)	Sensor Kit	1
18	45261	(040000–)	Spring	2
19	63185	(040000–)	Spring	2
20	50682	(040000–)	Sleeve	2
21	45960	(040000–)	Screw, Shoulder	2
22	05018	(040000–)	Actuator, 36 V	1
23	28608	(040480–)	Sensor Assembly, Mag Reed	1
24	49266	(040480–)	Tie, Cable	1
25	27921	(040000–)	Washer	1

Fig. 10 – Scrub Head Group



04770/05093

Ref.	Tennant Part No.	Machine Serial Number	Description	Qty.
1	04922	(040000–)	Motor 36 V (See Breakdowns)	2
2	00926	(040000–)	Key, Square	2
3	04928	(040000–)	Bearing, Flange	2
4	05076	(040000–)	Plate, Brush Drive	1
5	14841	(040000–)	Hub, Brush Drive	2
6	04927	(040000–)	Sleeve	1
7	05612	(040000–)	Sleeve, Scrub Head Rear	1

Fig. 11 – Tire and Rim Assembly

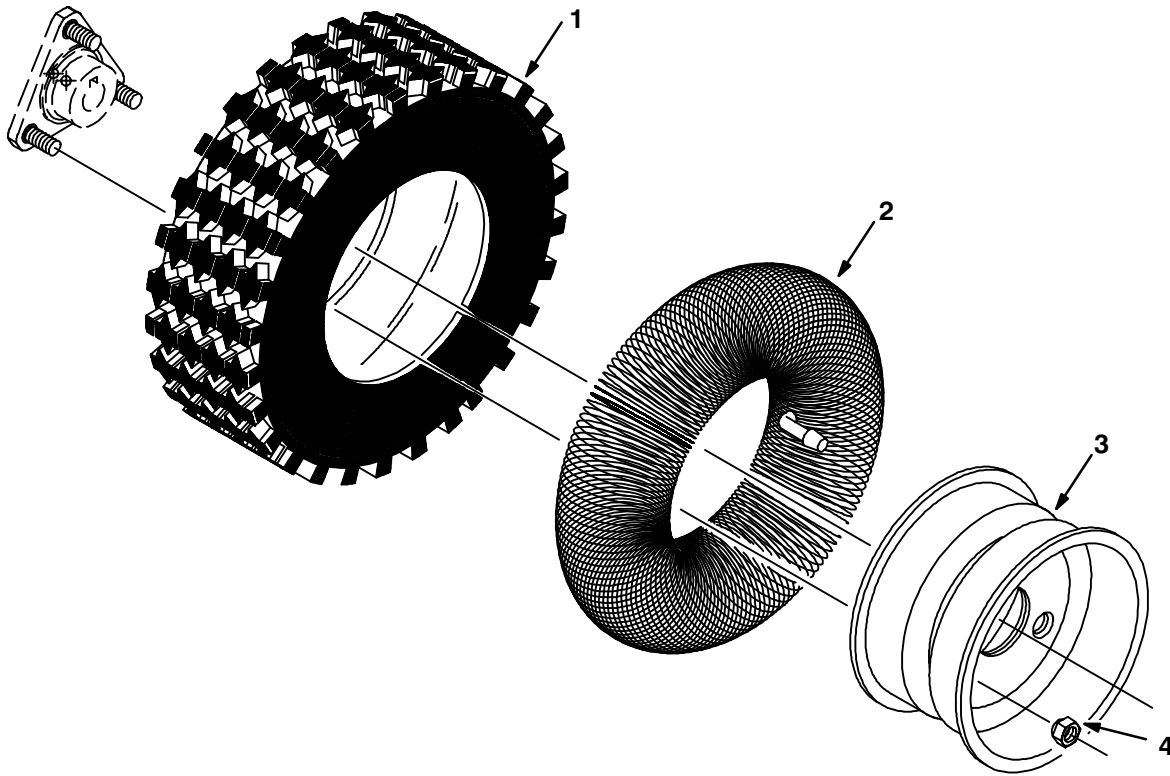

04782/04200

Ref.	Tennant Part No.	Machine Serial Number	Description	Qty.
▽	61597	(040000–) Tire and Rim Assembly	2
▲	1 61596	(040000–) Tire, Non-Marking	1
▲	2 04658	(040000–) Tube, Inner	1
▲	3 04657	(040000–) Rim	1
4	11109	(040000–) Nut, Wheel	6

Fig. 12 – Dual Drive Group

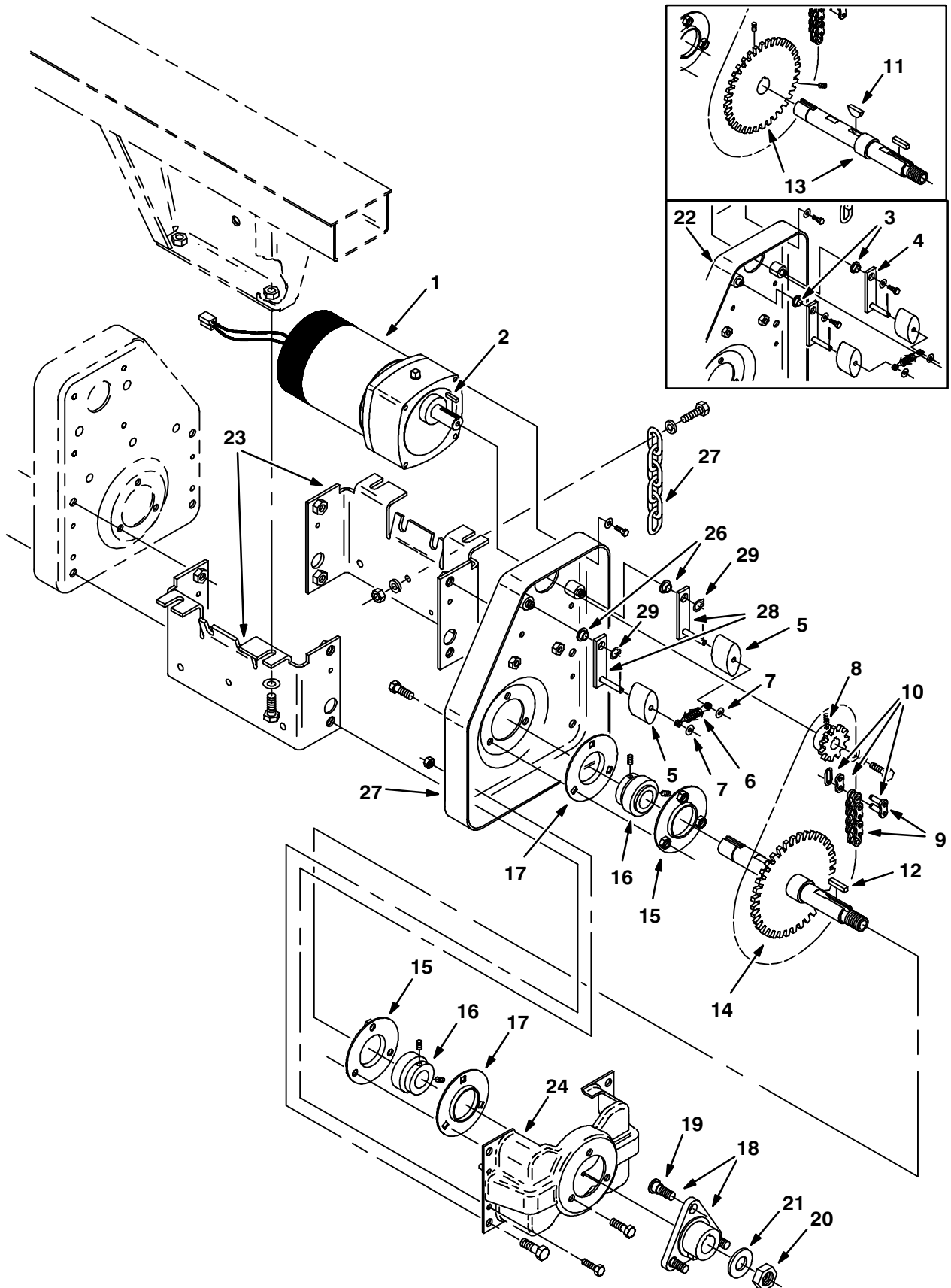

Fig. 12 – Dual Drive Group

Ref.	Tennant Part No.	Machine Serial Number	Description	Qty.
1	04656	(040000–)	Motor (See Breakdowns)	2
2	00911	(040000–)	Key, Square	2
3	05582	(040000–040544)	Bearing, Flange	4
4	24548	(040000–040544)	Arm Kit, Chain Tension	4
5	04671	(040000–)	Puck, Chain Tension	4
6	04720	(040000–)	Spring, Compression	2
7	05604	(040000–)	Wire, Spring	4
8	04672	(040000–)	Sprocket	2
▽	9	61415	(040000–) Chain and Link Assembly	2
▲	10	28272	(040000–) Link, Roller Chain	1
11	00500–15	(040000–040393)	Key, Woodruff	2
12	00928	(040000–)	Key, Square	2
13	33484	(040000–040393)	Shaft and Sprocket Replacement Kit	2
14	33422	(040394–)	Shaft and Sprocket	2
15	04746	(040000–)	Flange, Bearing Retainer	4
16	24684	(040000–)	Bearing Replacement Kit	4
17	36190	(040000–)	Flange	4
▽	18	04704	(040000–) Dual Drive Hub Assembly	2
▲	19	11117	(040000–) Stud, Wheel	3
20	08169	(040000–)	Nut, Nylon lock	2
21	04401	(040000–)	Washer, M20	2
22	24549	(040000–040544)	Housing, Chain	2
23	05572	(040000–)	Bracket, Drive Mounting	2
24	11088	(040000–)	Bracket, Bearing Support	2
25	47277	(040470–)	Chain, Static	1
26	15877	(040545–)	Bearing, Flange	4
27	33446	(040545–)	Case, Chain	2
28	24547	(040545–)	Arm, Chain Tensioner	4
29	24555	(040545–)	E–Ring, External	4

Fig. 13 – Solution And Recovery Tanks Group

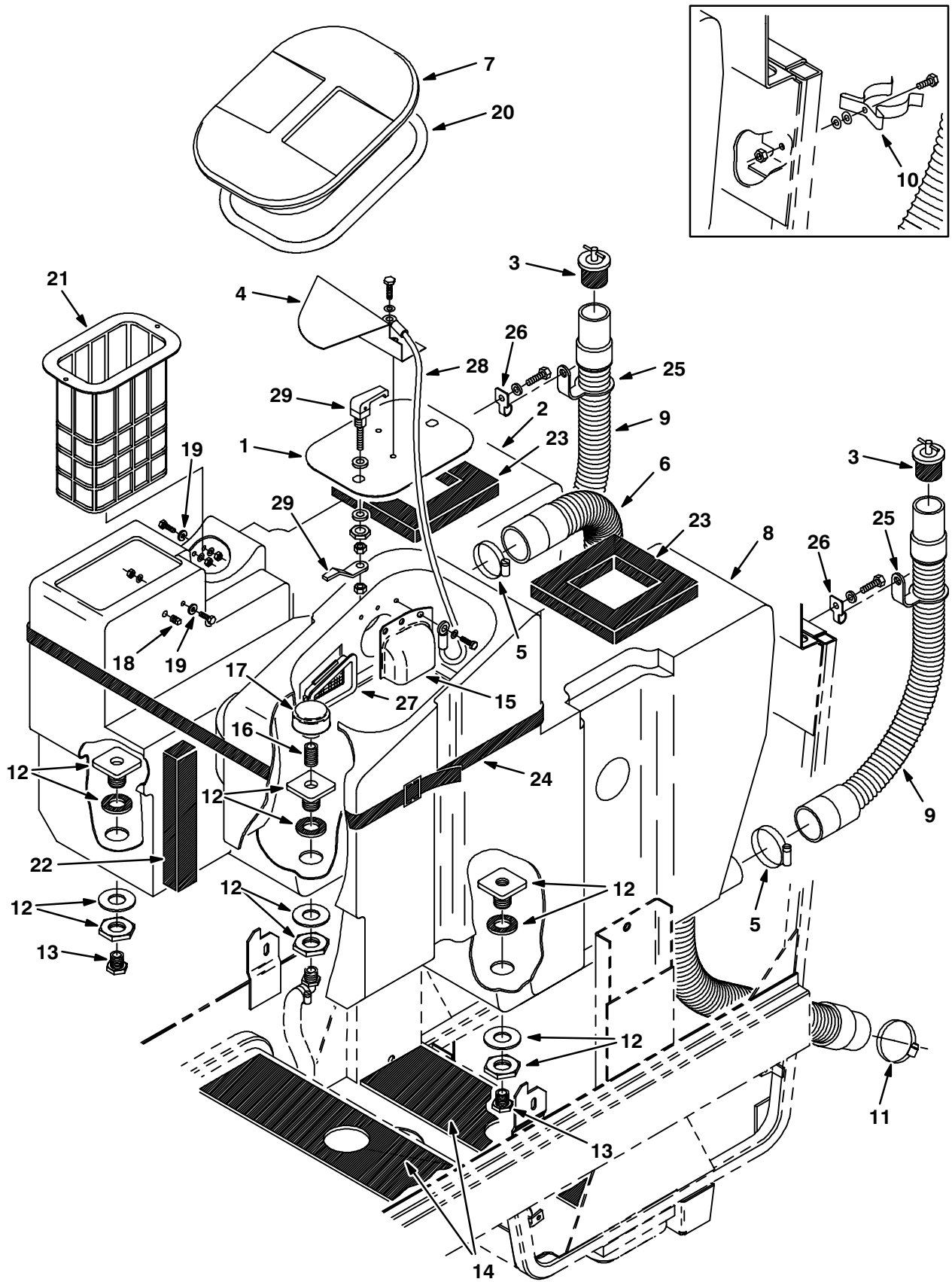

Fig. 13 – Solution And Recovery Tanks Group

Ref.	Tennant Part No.	Machine Serial Number	Description	Qty.
1	65552	(040000-040741)	Baffle Kit	1
1	65551	(040742-) Plate, Baffle	1
2	05016	(040000-) Tank, Solution	1
3	222396	(040000-) Stopper Assembly	2
4	11746	(040000-) Baffle, Tank	1
5	22297	(040000-) Clamp, Worm Drive	3
6	05216	(040000-) Hose, Squeegee	1
7	06137	(040000-) Cover, Recovery Tank	1
8	05017	(040000-) Tank Recovery	1
9	05127	(040000-) Hose, Drain	2
10	67004	(040000-040449)	Clip, Finger Grip	2
11	33344	(040000-) Clamp, Worm Drive	1
12	65566	(040000-) Fitting, Straight	3
13	75611	(040000-) Fitting, Plug	2
14	05675	(040000-) Pad, Tank	2
15	11750	(040000-) Baffle, Vacuum Fan	1
16	69784	(040000-) Fitting, Nipple	1
17	05218	(040000-) Strainer, Solution Tank	1
18	56119	(040000-) Fitting, Plug	1
19	76426	(040000-) Washer, Sealing	3
20	05165	(040000-) Seal, Recovery Tank Lid	1
21	43516A	(040000-) Basket, Soap	1
22	04832	(040000-) Pad, Foam	1
23	57828	(040000-) Foam	2
24	04836	(040000-) Strap, Poly	1
25	24663	(040450-) Strap, Drain Hose	2
26	24638	(040450-) Clip, Drain Hose	2
27	05089	(040000-) Screen	1
28	19676	(040000-) Lanyard	1
29	65695	(040742-) Latch, Lift and Turn, Adjustable	2

Fig. 14 – Recovery Tank Float Group

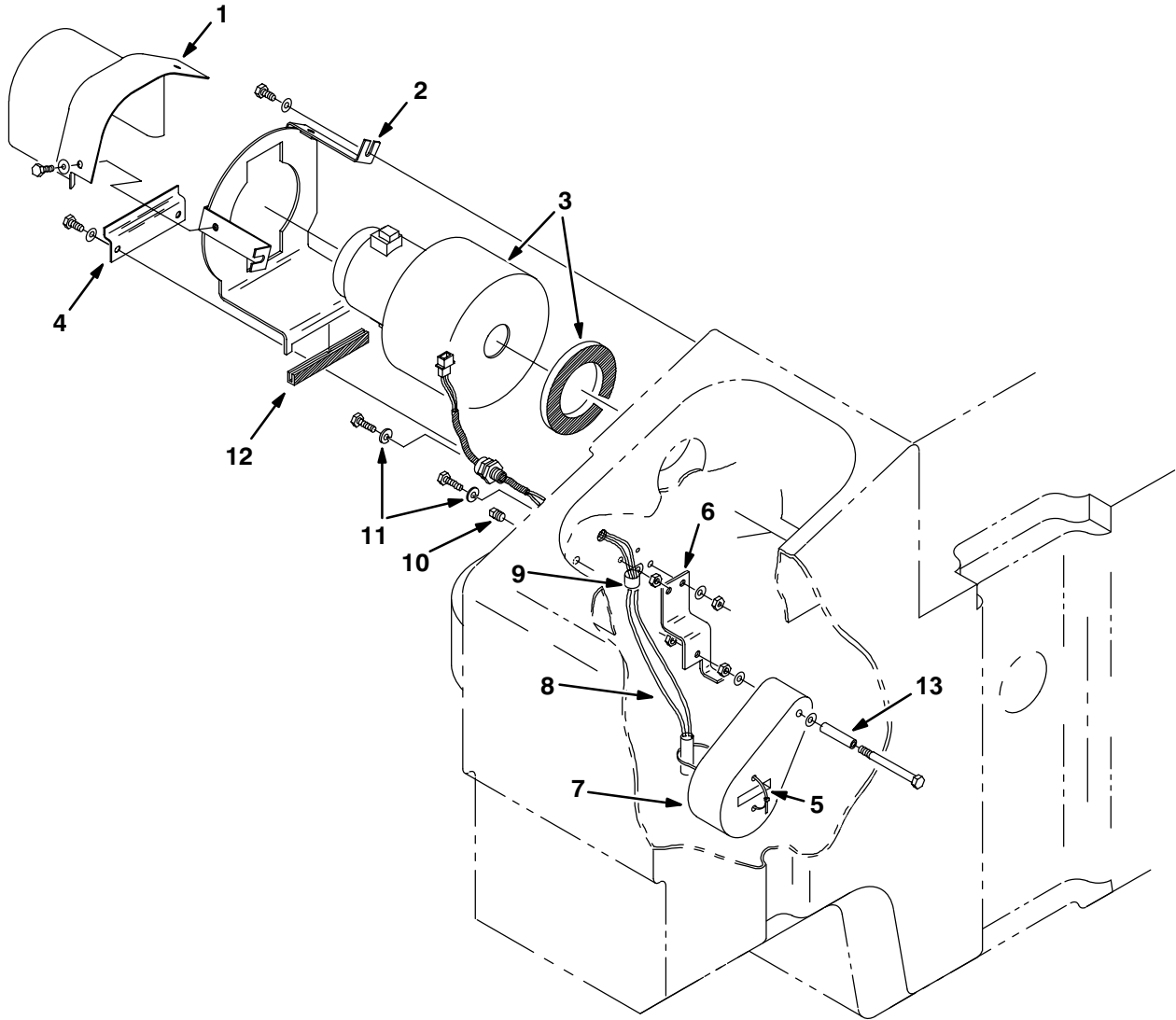

Fig. 14 – Recovery Tank Float Group

Ref.	Tennant Part No.	Machine Serial Number	Description	Qty.
1	10936	(040000–) Guard, Vacuum Fan	1
2	06174	(040000–) Bracket, Vacuum Fan	1
3	10914	(040000–) Fan, Vacuum (See Breakdowns)	1
4	06146	(040000–) Bracket, Mounting	1
5	49266	(040000–) Tie, Cable	1
6	05567	(040000–) Bracket, Water Level Control	1
7	65683	(040000–) Float, Water Level	1
8	10935	(040000–040271) Mercury Switch Assembly	1
8	28346	(040272–) Mercury Switch Assembly	1
9	33584	(040000–) Clamp, Cable	1
10	56119	(040000–) Fitting, Plug	1
11	76426	(040000–) Washer, Sealing	3
12	10911	(040000–) Isolator, Vacuum Fan	1
13	78551	(040000–) Tube	1

Fig. 15 – Solution Control Group

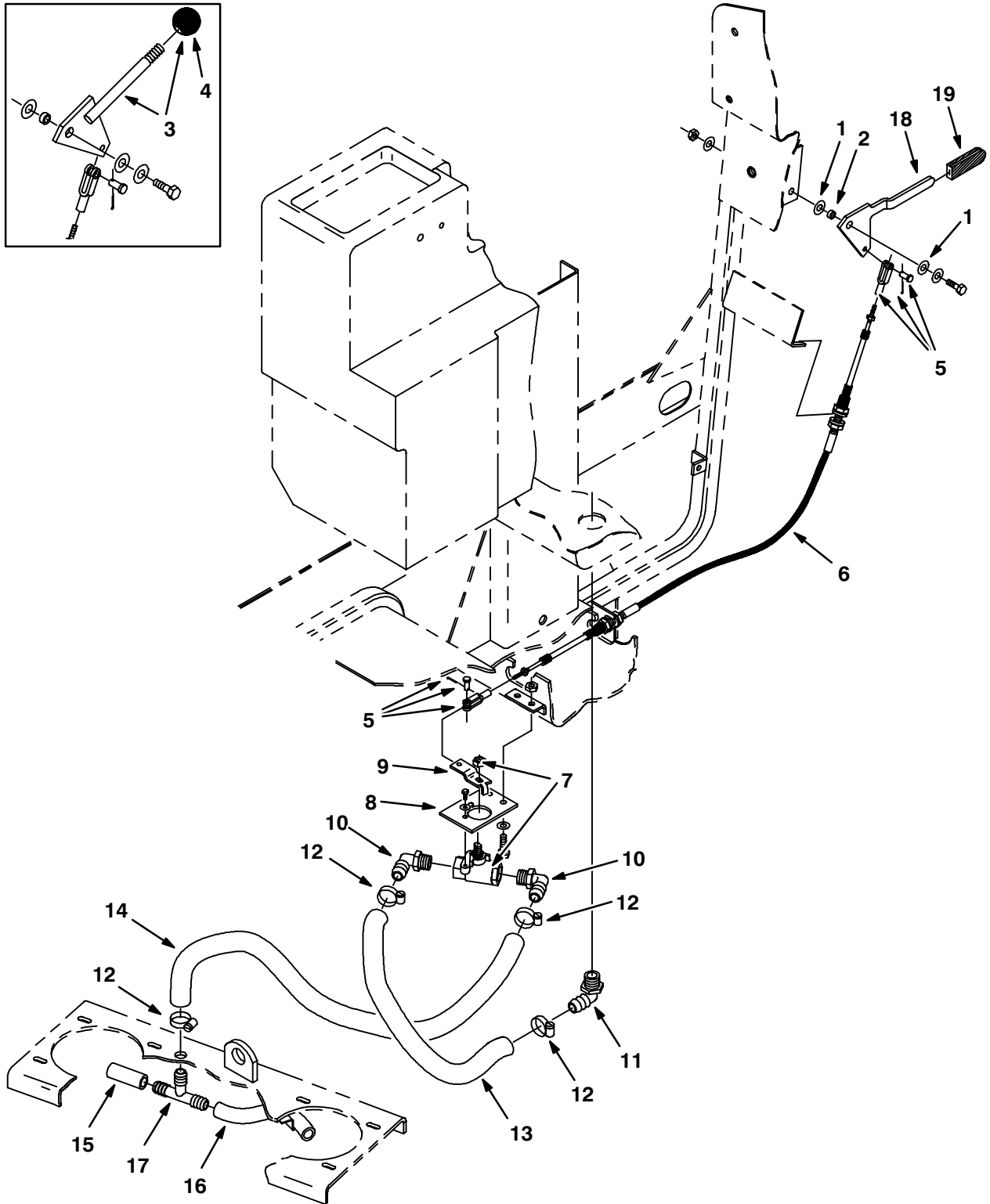

Fig. 15 – Solution Control Group

Ref.	Tennant Part No.	Machine Serial Number	Description	Qty.
1	43611	(040000–)	Washer, Nylon	2
2	63342	(040000–)	Sleeve	1
3	33441	(040000–040333)	Water Handle Kit	1
4	26565	(040000–040333)	Knob	1
5	27880	(040000–)	Yoke Assembly	2
6	05670	(040000–)	Cable, Push Pull	1
7	12083	(040000–)	Water, Valve	1
8	05294	(040000–)	Bracket, Valve Mounting	1
9	05669	(040000–)	Arm, Water Valve	1
10	63244–1	(040000–)	Fitting, Barbed Elbow	2
11	63244–3	(040000–)	Fitting, Barbed Elbow	1
12	54333	(040000–)	Clamp, Worm Drive	4
13	05714	(040000–)	Hose, PVC	1
14	05712	(040000–)	Hose, Clear Vinyl	1
15	05711	(040000–)	Hose, Clear Vinyl	1
16	05717	(040000–)	Hose, Clear Vinyl	1
17	63245–1	(040000–)	Fitting, Barbed Tee	1
18	33438	(040334–)	Lever, Control	1
19	33439	(040334–)	Grip, Handle	1

Fig. 16 – Battery Group

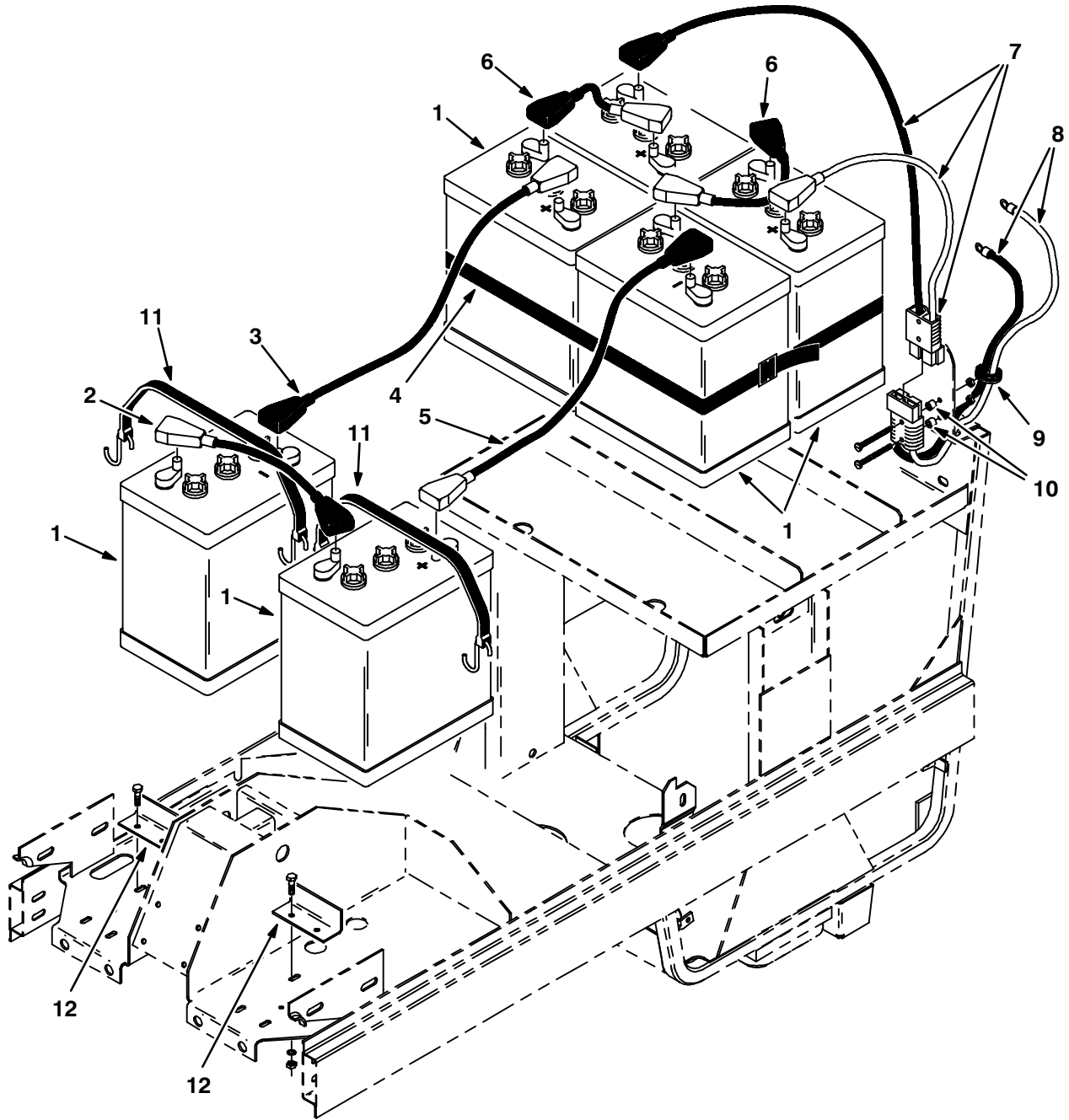

Fig. 16 – Battery Group

Ref.	Tennant Part No.	Machine Serial Number	Description	Qty.
1	11230	(040000-040230)	Battery, 6 V, Wet (Replaced by 10155)	6
1	11229	(040000-040230)	Battery, 6 V, Dry (International Only)	6
2	05251	(040000-040230)	Cable, Battery	1
3	63757	(040000-040230)	Cable, Battery	1
4	04836	(040000-040230)	Strap, Poly, Webbing	1
5	05252	(040000-040230)	Cable, Battery	1
6	63755	(040000-040230)	Cable, Battery	2
7	05671	(040000-040230)	Cable, Battery	1
8	05672	(040000-040230)	Cable, Battery	1
9	10632	(040000-040230)	Grommet, Rubber	1
10	65742	(040000-040230)	Sleeve	2
11	33671	(040000-040230)	Strap, Rubber, Tie-down	2
12	04684	(040000-040230)	Angle, Battery Stop	2

Fig. 17 – Battery Group

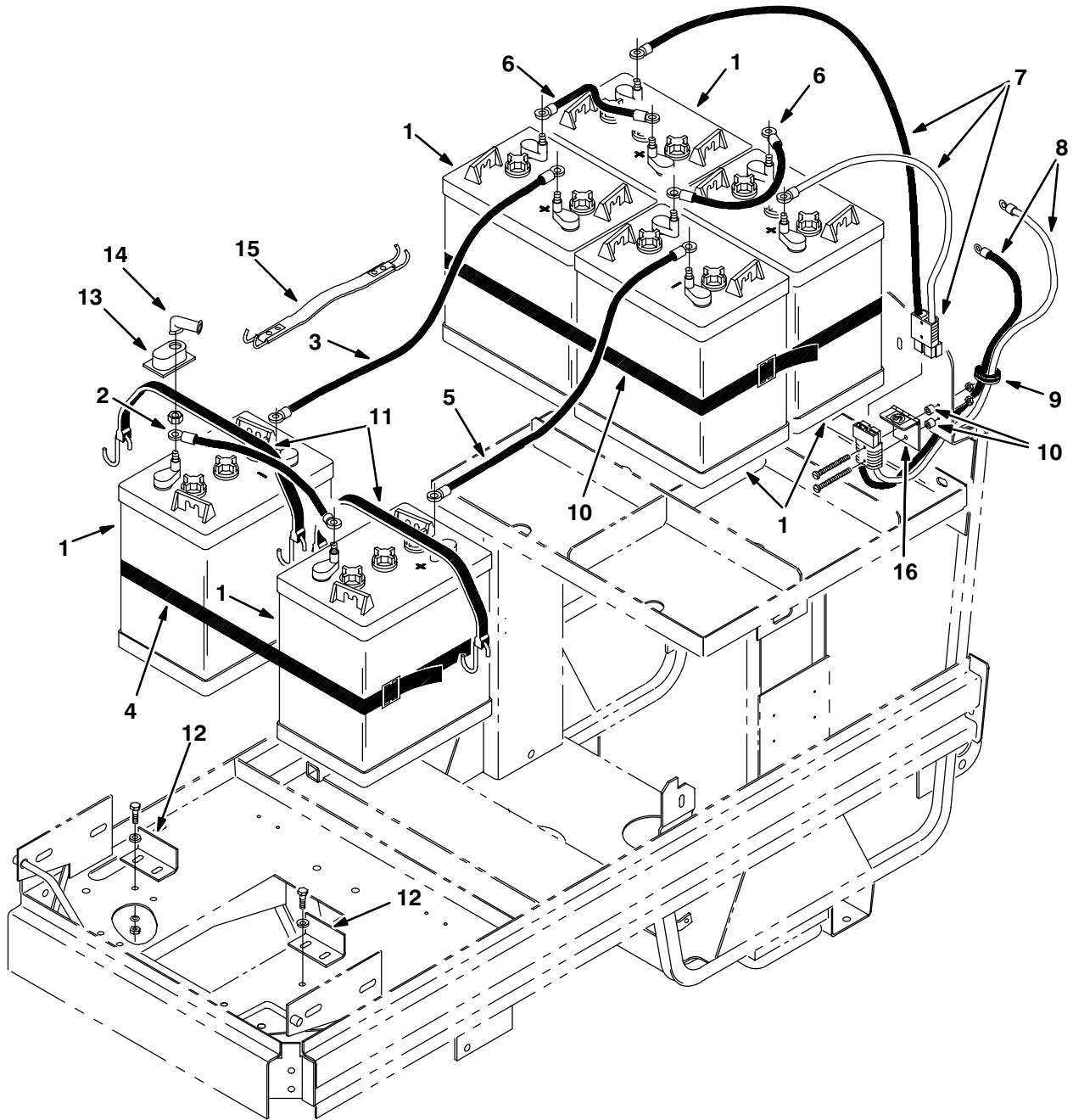

Fig. 17 – Battery Group

Ref.	Tennant Part No.	Machine Serial Number	Description	Qty.
1	10155	(040231–)	Battery, 6 V, Wet	6
1	11229	(040231–)	Battery, 6 V, Dry (International Only)	6
2	28333	(040231–)	Cable, Battery	1
3	28334	(040231–)	Cable, Battery	1
4	04836	(040231–)	Strap, Poly, Webbing	2
5	28335	(040231–)	Cable, Battery	1
6	63740	(040231–)	Cable, Battery	2
7	28332	(040231–)	Cable, Battery	1
8	05672	(040231–)	Cable, Battery	1
9	10632	(040231–)	Grommet	1
10	65742	(040231–)	Sleeve	2
11	33671	(040231–)	Strap, Rubber, Tie-down	2
12	04684	(040231–040469)	Angle, Battery Stop	2
12	24843	(040470–)	Angle, Battery Stop	2
13	45962	(040231–)	Cover, Terminal	12
14	02076	(040231–)	Cover, Terminal	12
15	28286	(040231–)	Strap, Battery Lift	1
16	65744	(040231–)	Hinge, W/Label, SB50	1

Fig. 18 – Steering Control Group

Ref.	Tennant Part No.	Machine Serial Number	Description	Qty.
1	04761	(040000–040206)	Bearing, Flange	2
2	04762	(040000–)	Spring, Torsion Centering	1
3	04763	(040000–)	Hub and Gear	1
4	04766	(040000–)	Collar, Shaft	1
5	27974	(040207–)	Gear	1
6	27957	(040207–)	Potentiometer Replacement Kit	1
7	04760	(040000–)	Handle, Speed Control	1
8	06208	(040000–)	Washer	2
9	04765	(040000–)	Grip, Handle	2
10	27934	(040207–)	Bracket, Handle	1
11	05611	(040000–)	Isolator, Vibration	2
12	63846	(040000–)	Switch, Push Button	2
13	86730	(040000–)	Nut, Hex, Thin	2
14	04767	(040000–)	Stop, Spring	1
15	27972	(040000–040206)	Potentiometer Replacement Kit	1
16	05582	(040000–040206)	Bearing, Flange	2
17	27973	(040207–)	Bracket, Potentiometer	1
18	27937	(040207–)	Bearing, Flange	2
19	55248	(040000–)	Mount, Cable Tie	1
20	49266	(040000–)	Tie, Cable	1
21	86730	(040207–)	Nut, Hex, Thin	1
22	82226	(040000–)	Washer	1

Fig. 19 – Rear Electrical Panel Group

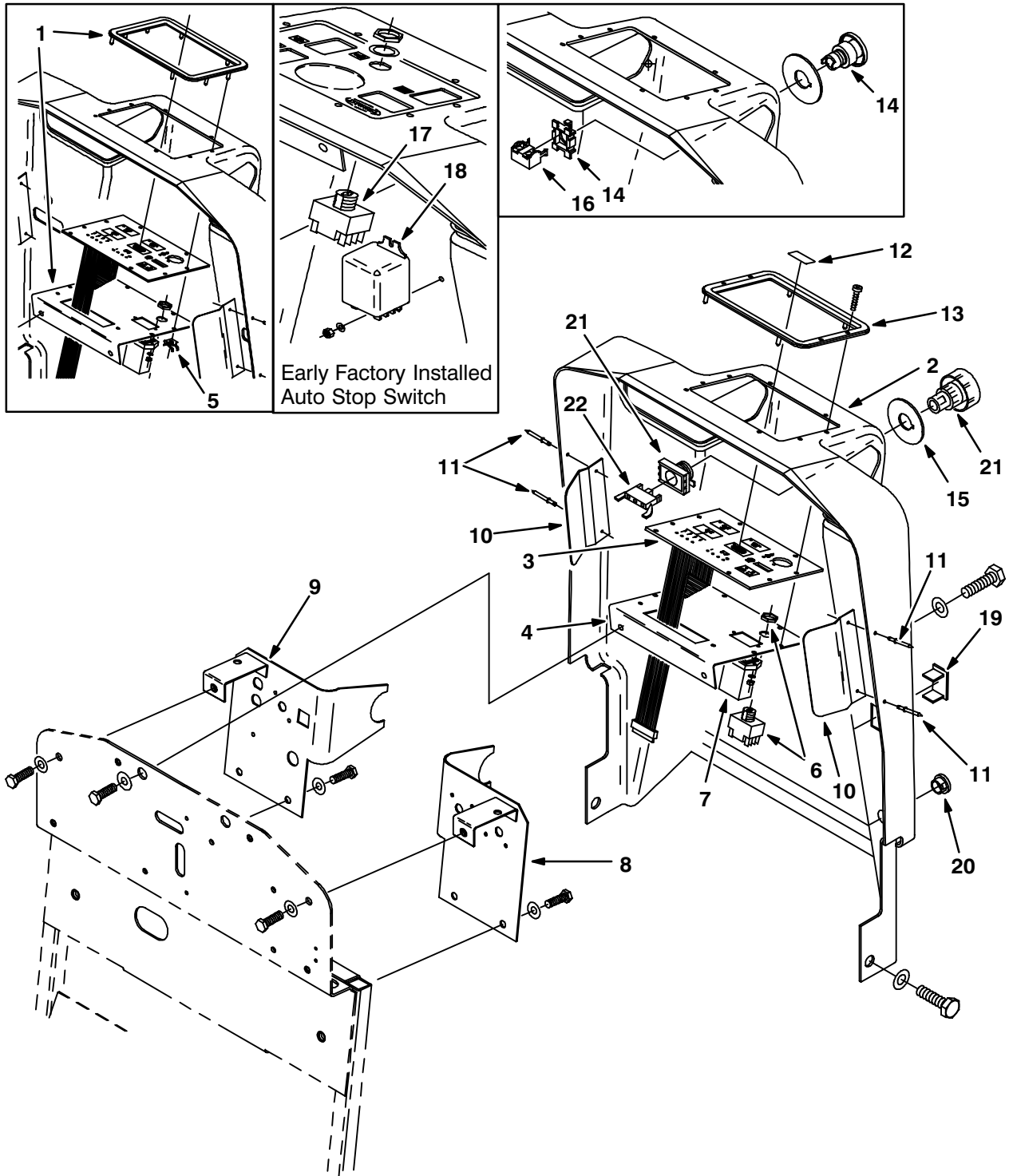
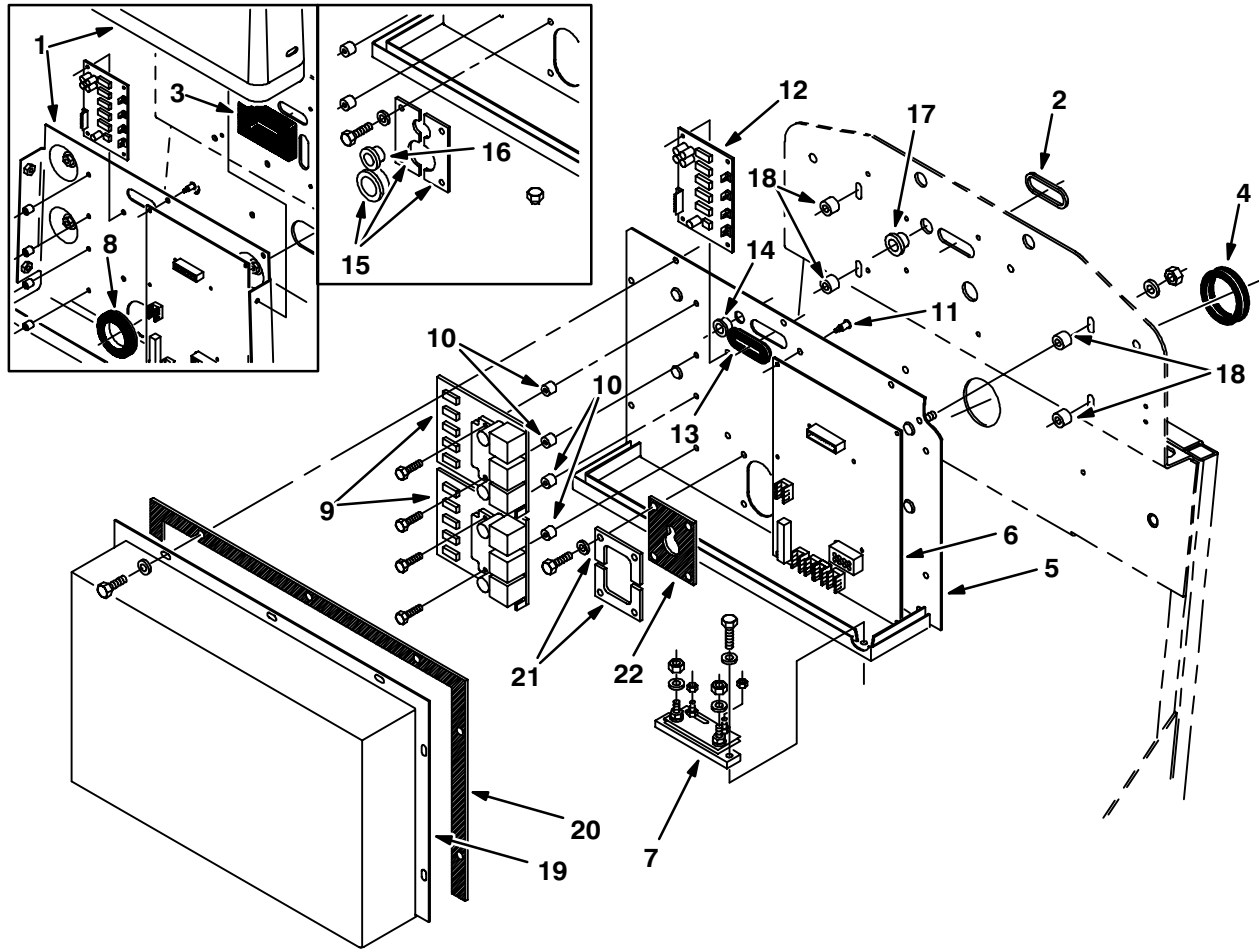

Fig. 19 – Rear Electrical Panel Group

Ref.	Tennant Part No.	Machine Serial Number	Description	Qty.	
1	33408	(040000–040449)	Instrument Panel and Bezel kit	1	
2	65598	(040000–)	Panel and Label Assembly, Rear	1	
3	65565	(040000–)	Panel, Touch Switch	1	
4	33470	(040450–)	Bracket, Touch Panel	1	
5	05280	(040000–040449)	Clip, Stud	8	
▽	6	31203	(040000–)	Key Switch Assembly	1
▲	31204	(040000–)	Key, Switch	1	
7	31988	(040000–)	Hourmeter	1	
8	04957	(040000–)	Plate, Circuit Breaker Mounting	1	
9	28416	(040000–)	Plate, Circuit Breaker Mounting	1	
10	05027	(040000–)	Guide, Cover, Rear	2	
11	56799	(040000–)	Rivet, Pop	4	
12	11744	(040000–)	Label, ES™ Cover	1	
13	33492	(040450–)	Bezel, Touch Panel	1	
14	28429	(040000–040785)	Switch, Push Button	1	
15	28428	(040000–)	Plate, Stop Button	1	
16	11608	(040000–040785)	Contacts, Switch	2	
▽	17	11651	(040000–040445)	Switch Assembly	1
▲	31204	(040000–040445)	Key, Switch	1	
18	87284	(040000–040445)	Relay, DPDT	1	
19	57772	(040000–)	Plate, Cover	2	
20	65584	(040000–)	Plugbutton	1	
21	65664	(040786–)	Switch, Push Button	1	
22	65665	(040786–)	Contacts, Switch	1	

Fig. 20 – Electrical Controller Group



05072/04777

Ref.	Tennant Part No.	Machine Serial Number	Description	Qty.
1	27950	(040000–040187)	Cover and Panel Replacement Kit	1
2	11708	(040000–)	Grommet, Flexible	1
3	06126	(040000–040187)	Seal, Electrical Panel (Replaced by 27928)	1
4	10632–19	(040000–)	Grommet	1
5	27941	(040188–)	Panel, Electric	1
6	27960	(040000–)	Control Board Kit	1
7	10973	(040000–)	Shunt	1
8	56390	(040000–040187)	Grommet	1
9	27961	(040000–)	Controller Kit, Dual	2
10	65742	(040000–)	Sleeve	4
11	15840	(040000–)	Pin, Prong	14
12	27962	(040000–)	Board Kit, Interface Steering	1
13	27928	(040188–)	Grommet, Ribbon Cable	1
14	27947	(040188–)	Grommet	1
15	28341	(040188–040529)	Grommet Replacement Kit	2
16	27948	(040188–040529)	Grommet	1
17	27948	(040188–)	Grommet	1
18	40282	(040188–)	Sleeve	4
19	27951	(040188–)	Cover and Label Kit, Electric Panel	1
20	27945	(040188–)	Gasket, Electric Panel	1
21	27914	(040530–)	Plate, Harness	2
22	27915	(040530–)	Grommet, Harness	1

Fig. 21 – Rear Electrical Group

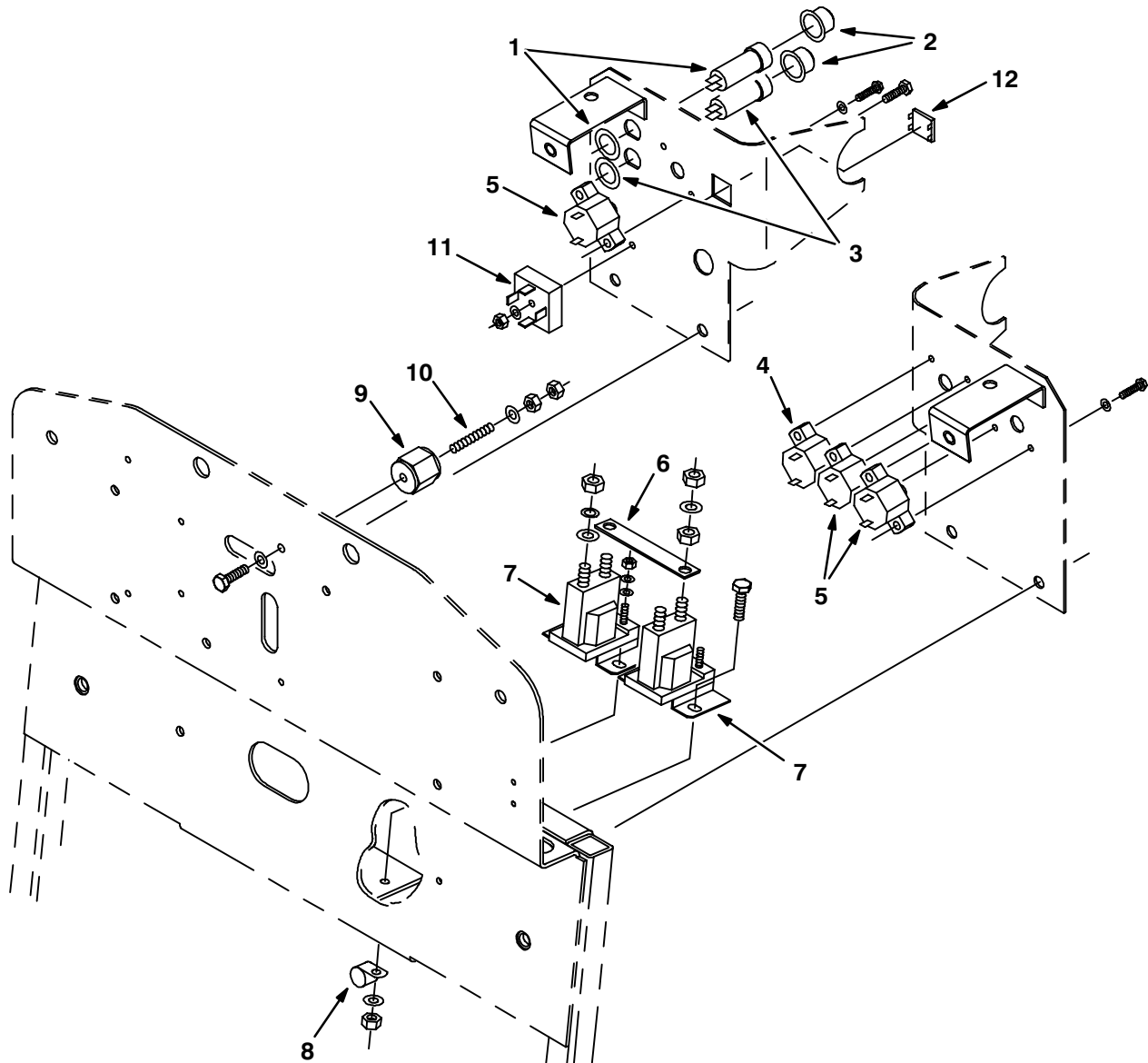

05074/04776

Ref.	Tenant Part No.	Machine Serial Number	Description	Qty.
1	27920	(040000–)	Breaker, Circuit, 5 A	1
2	57751	(040000–)	Boot, Circuit Breaker	2
3	57164	(040000–)	Breaker, Circuit, 10 A	1
4	27967	(040000–)	Breaker, Circuit, 20 A	1
5	63030–2	(040000–)	Breaker, Circuit, 25 A	3
6	10967	(040000–)	Busbar, Relay	1
7	04685	(040000–)	Contactors	2
8	26395–1	(040000–)	Clamp, Cable	1
9	76062	(040000–)	Insulator, Panel and Switchboard	1
10	41702	(040000–)	Rod, Threaded	1
11	10962	(040000–)	Diode, Bridge, 12 A	1
12	28426	(040457–)	Plugbutton	1

Fig. 22 – Rear Squeegee Link Group

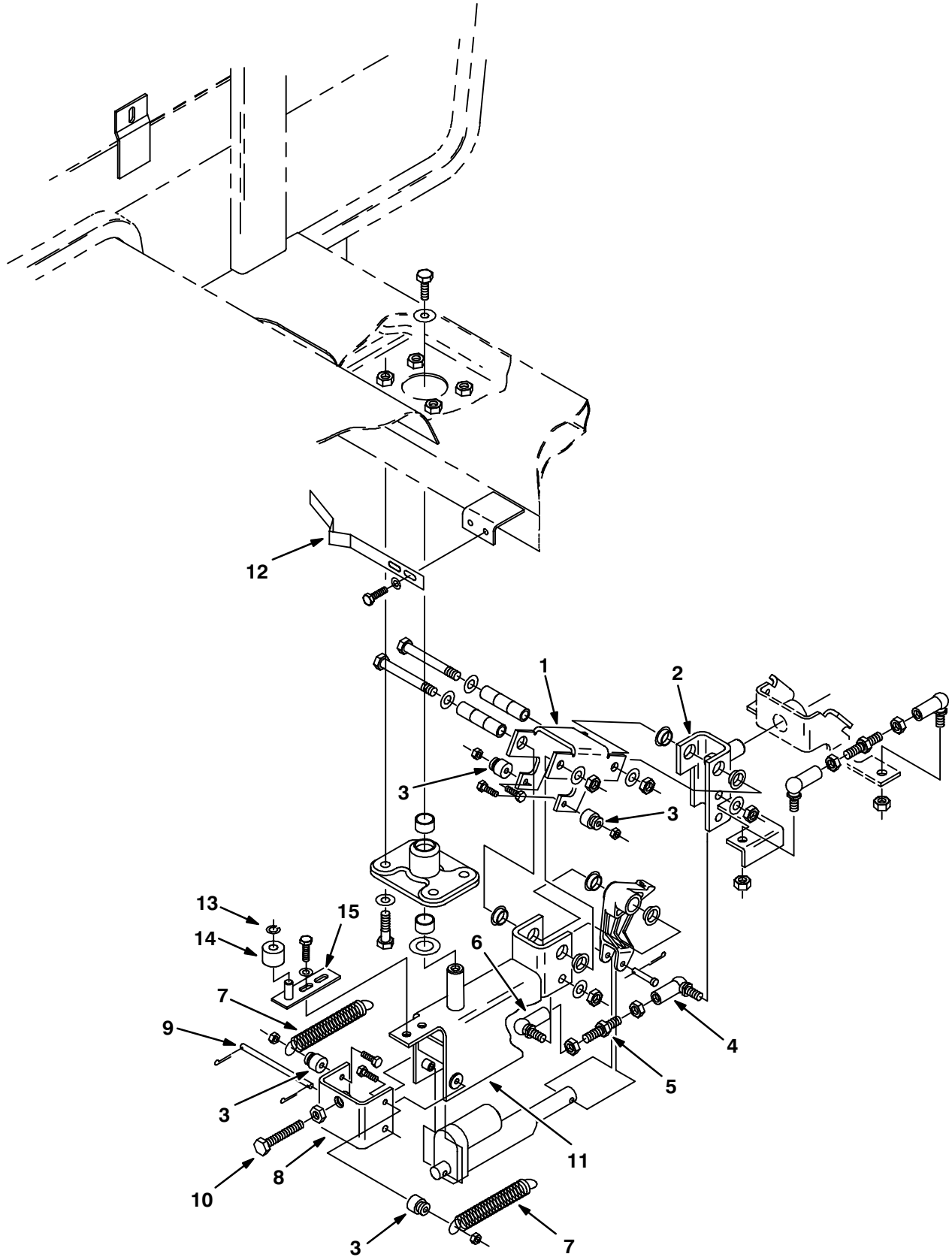

Fig. 22 – Rear Squeegee Link Group

Ref.	Tennant Part No.	Machine Serial Number	Description	Qty.
1	04853	(040000-040160)	Bracket, Squeegee Lift	1
2	04849	(040000-040160)	Bracket, Squeegee Lift	1
3	05120	(040000-040160)	Retainer, Spring	4
4	05291	(040000-040160)	Rod End, M10, L.H.	1
5	04869	(040000-040160)	Stud, Adjustment	1
6	05290	(040000-040160)	Rod End, M10, R.H.	1
7	04854	(040000-040160)	Spring, Tension	2
8	05678	(040000-040160)	Bracket, Spring Adjustment	1
19	05282	(040000-040160)	Pin, Actuator Mount	1
10	06419	(040000-040160)	Bolt, Adjustment	1
11	04856	(040000-040160)	Bracket, Squeegee Pivot (replaced by 33398)	1
12	63212	(040000-040291)	Spring, Squeegee Centering	1
13	23514-1	(040000-040291)	Ring, Retaining	1
14	63878	(040000-040291)	Roller	1
15	11679	(040000-040291)	Bracket, Roller	1

Fig. 23 – Rear Squeegee Link Group

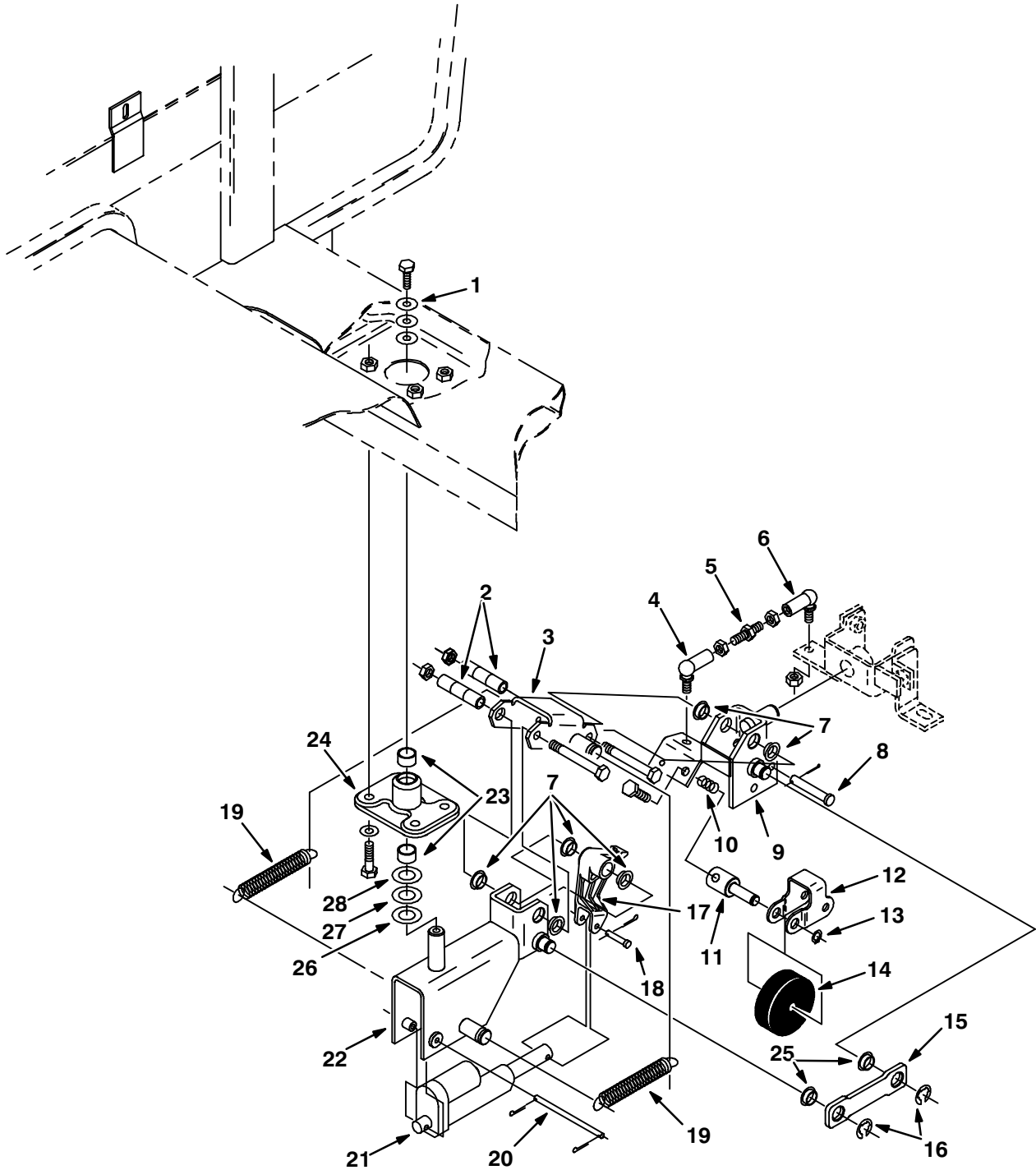

Fig. 23 – Rear Squeegee Link Group

Ref.	Tennant Part No.	Machine Serial Number	Description	Qty.
1	05624	(040000–) Washer	1
2	05145	(040000–) Sleeve, Squeegee Lift	2
3	33362	(040161–) Bracket, Squeegee Lift	1
4	82962	(040000–) Ball Joint, L.H.	1
5	11676	(040000–) Stud, Adjustment	1
6	63282	(040000–) Ball Joint, R.H.	1
7	04843	(040000–) Bearing, Flange	6
8	33355	(040161–) Pin, Clevis	1
9	33348	(040161–) Bracket, Squeegee Lift	1
10	33498	(040161–) Spring	1
11	33379	(040161–) Axle, Caster Adjustment	1
12	33499	(040161–) Bracket, Caster	1
13	05284	(040161–) Clip, Retainer	1
14	86800	(040161–) Wheel	1
15	33371	(040161–) Link, Connecting	1
16	33373	(040161–) Ring, Retaining	2
17	04845	(040000–) Arm, Lift	1
18	05283	(040000–) Pin, Clevis	1
19	33395	(040161–) Spring, Tension	2
20	33391	(040161–) Pin, Actuator	1
21	48679	(040000–) Actuator	1
22	33388	(040161–) Bracket, Pivot, Squeegee	1
23	64377	(040000–) Bearing, Journal	2
24	05099	(040000–) Flange, Squeegee	1
25	04843	(040161–) Bearing, Flange	2
26	64489	(040161–) Washer	1
27	40847–1	(040000–) Shim	–
28	04846	(040000–) Washer, Thrust	1

Fig. 24 – Rear Squeegee Group

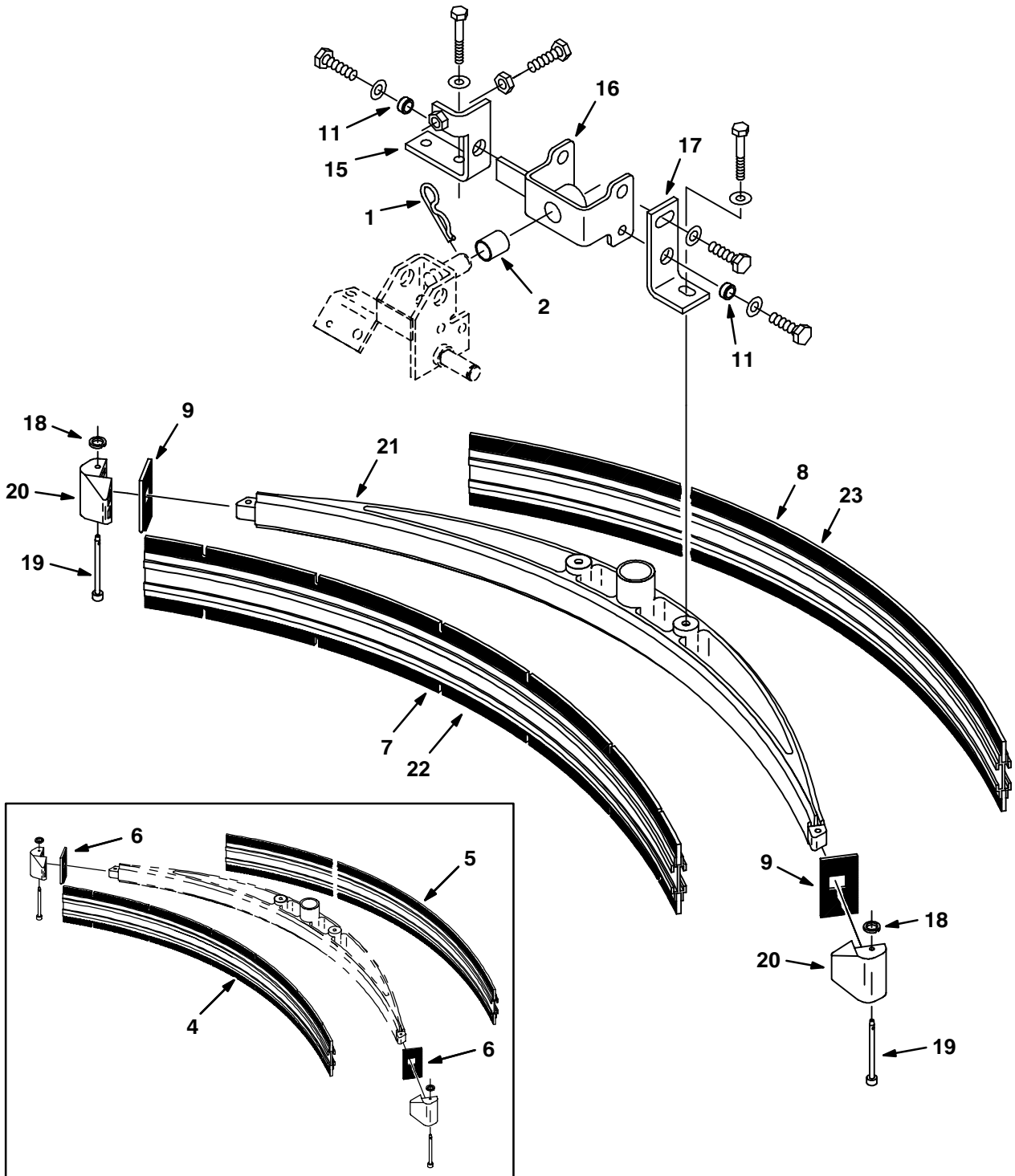
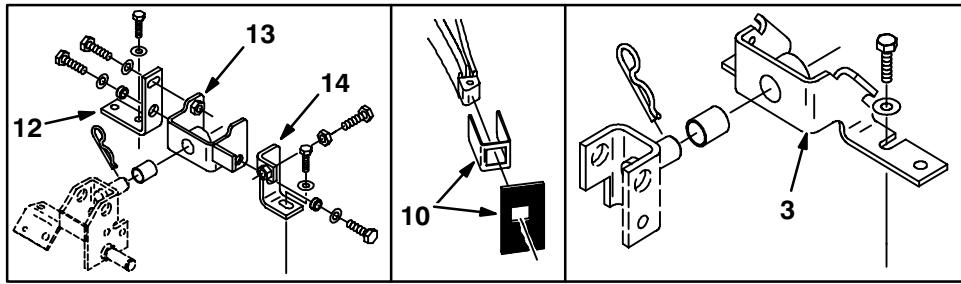
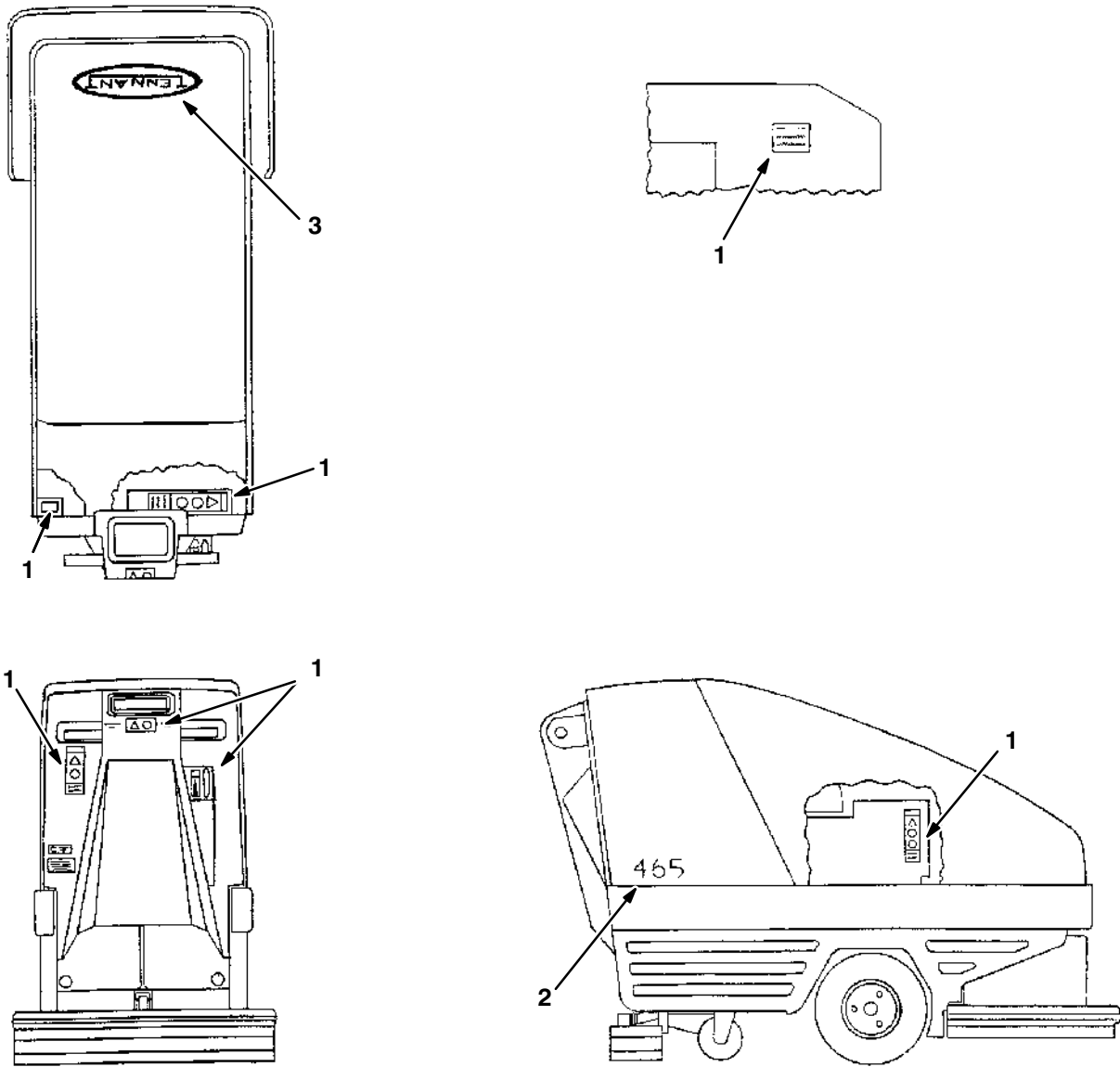

Fig. 24 – Rear Squeegee Group

Ref.	Tennant Part No.	Machine Serial Number	Description	Qty.
1	55094	(040000–)	Pin, Hair Cotter	1
2	04844	(040000–)	Bearing, Journal	1
3	04852	(040000–040160)	Bracket, Squeegee, Pivot	1
▽	11485	(040000–040385)	Squeegee Blade Kit, Short	1
▲	4	04916	(040000–040385) Squeegee Blade Assembly, Front	1
▲	5	04919	(040000–040385) Squeegee Blade Assembly, Rear	1
▲	6	33437	(040000–040385) Blade, Squeegee End	2
▽	24687	(040386–)	Squeegee Blade Kit, Long	1
▲	7	33424	(040386–) Squeegee Blade Assembly, Front	1
▲	8	33354	(040386–) Squeegee Blade Assembly, Rear	1
▲	9	11283	(040386–) Blade, Squeegee End	2
10	27952	(040000–040291)	Squeegee End Replacement Kit (For both sides)	1
11	33369	(040161–)	Sleeve, Squeegee	2
12	33378	(040161–040496)	Bracket, Adjuster, R.H.	1
13	33376	(040161–040496)	Bracket, Squeegee, Pivot	1
14	33377	(040161–040496)	Bracket, Adjuster, L.H.	1
15	04819	(040497–)	Bracket, Adjuster, R.H.	1
16	04809	(040497–)	Bracket, Squeegee, Pivot	1
17	04808	(040497–)	Bracket, Adjuster, L.H.	1
18	49708	(040000–)	Ring, Split	2
19	33403	(040000–)	Pin, Clevis	2
20	04752	(040000–)	Bumper, Squeegee	2
21	24633	(040000–)	Body, Squeegee	1
22	78546	(040386–)	Squeegee Blade Assembly, Front, Urethane	1
23	78547	(040386–)	Squeegee Blade Assembly, Rear, Urethane	1

Fig. 26 – Label Group



05102/05098

Ref.	Tennant Part No.	Machine Serial Number	Description	Qty.
1	11541	(040000–)	Label Set, Information and Hazard	1
2	11664	(040000–)	Label, Numerals 1480	2
3	86877	(040000–)	Label, TENNANT Logo, White	1

SECTION 8

CONTENTS

	Page
Fig. 1 – Recommended General Maintenance Items	8-2
Fig. 2 – Replacement Brushes	8-3
Fig. 3 – Hood and Bumper Group	8-4
Fig. 4 – Main Frame Group	8-6
Fig. 5 – Front Shroud Group	8-8
Fig. 6 – Scrub Head Lift Group	8-10
Fig. 7 – Scrub Head Group	8-12
Fig. 8 – Tire and Rim Assembly	8-13
Fig. 9 – Dual Drive Group	8-14
Fig. 10 – Solution and Recovery Tanks Group	8-16
Fig. 11 – Vacuum Fan Group	8-18
Fig. 12 – Solution Control Group	8-20
Fig. 13 – Battery Group	8-22
Fig. 14 – Steering Control Group	8-24
Fig. 15 – Rear Electrical Panel Group	8-26
Fig. 16 – Electrical Controller Group	8-28
Fig. 17 – Rear Electrical Group	8-29
Fig. 18 – Rear Squeegee Link Group	8-30
Fig. 19 – Rear Squeegee Group	8-32
Fig. 20 – Label Group	8-33
Fig. 21 – Wire Harness Group	8-34

Fig. 1 – Recommended General Maintenance Items

	Ref.	Tennant Part No.	Machine Serial Number	Description	Qty.
▽		33475	(070000–)	Squeegee Blade Kit	1
▲		33588	(070000–)	Squeegee Blade Assembly, Front	1
▲		33590	(070000–)	Squeegee Blade Assembly, Rear	1
▲		11283	(070000–)	Blade, Squeegee End	2
		78548	(070000–)	Squeegee Blade Assembly, Front, Urethane	1
		78549	(070000–)	Squeegee Blade Assembly, Rear, Urethane	1

Fig. 2 – Replacement Brushes

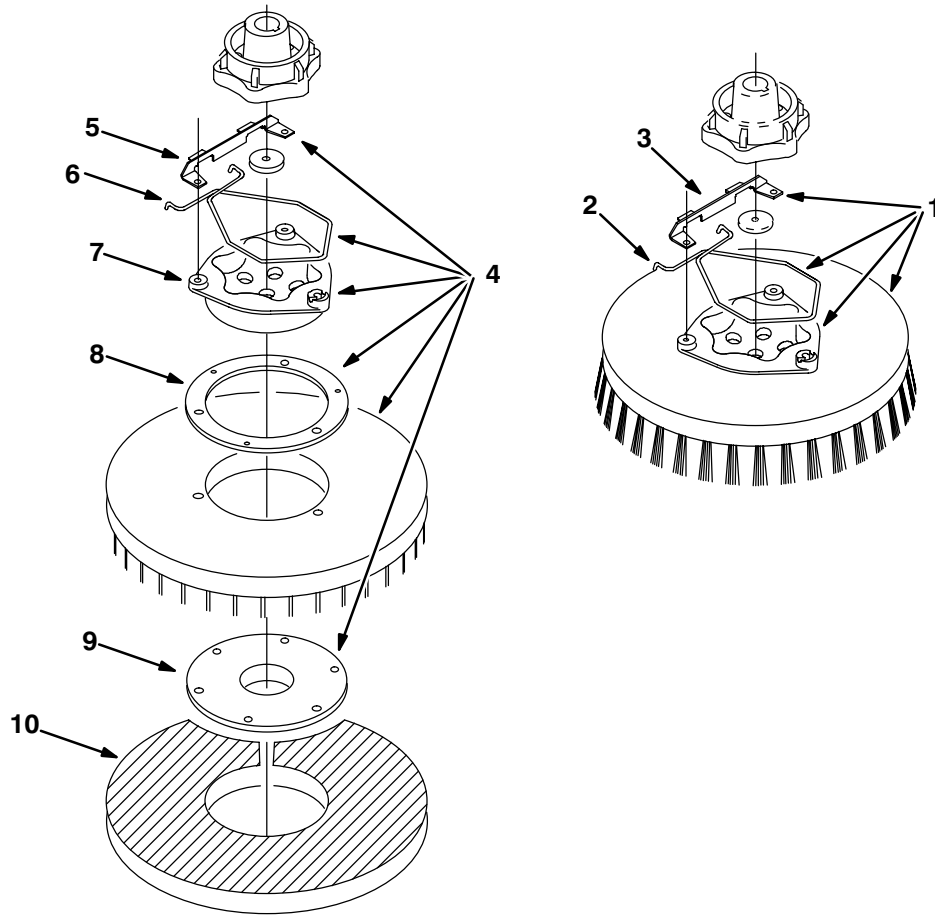

06301/06301

Ref.	Tennant Part No.	Machine Serial Number	Description	Qty.
▽	1	11771	(000000–) Scrub Brush Assembly, Polypropylene	2
▲	2	14838	(000000–) Spring, Brush Retaining	1
▲	3	24299	(000000–) Bracket, Spring Retainer	1
▽		11773	(000000–) Scrub Brush Assembly, Soft Nylon	2
▲		14838	(000000–) Spring, Brush Retaining	1
▲		24299	(000000–) Bracket, Spring Retainer	1
▽		11772	(000000–) Scrub Brush Assembly, Abrasive	2
▲		14838	(000000–) Spring, Brush Retaining	1
▲		24299	(000000–) Bracket, Spring Retainer	1
▽	4	11776	(000000–) Scrub Driver Pad Assembly, Polypropylene	1
▲	5	24299	(000000–) Bracket, Retainer Spring	1
▲	6	14838	(000000–) Spring, Brush Retaining	1
▲	7	15539	(000000–) Adaptor, Brush	1
▲	8	11218	(000000–) Spacer, Pad Holder	1
▲	9	19783	(000000–) Holder, Pad	1
	10	11777	(000000–) Pad, Stripper, Brown	2
		11778	(000000–) Pad, Scrubber, Blue	2
		11780	(000000–) Pad, Buffer, Red	2
		11781	(000000–) Pad, Polish, White	2

Fig. 3 – Hood and Bumper Group

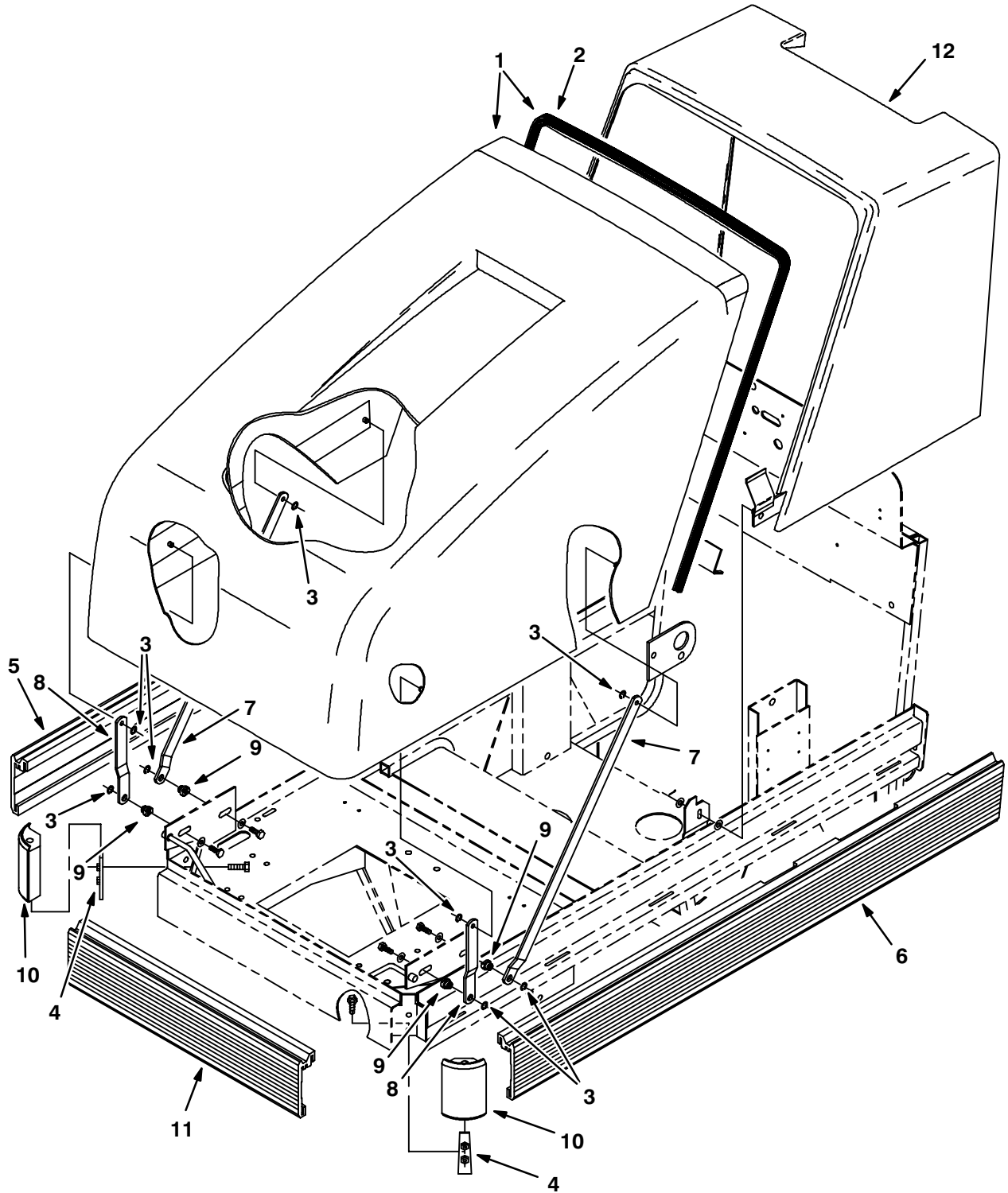

Fig. 3 – Hood and Bumper Group

	Ref.	Tennant Part No.	Machine Serial Number	Description	Qty.
▽	1	05574	(070000–)	Cover, Front	1
▲	2	33360	(070000–)	Seal	1
	3	05284	(070000–)	Clip, Retainer	8
	4	33454	(070000–)	Plate, Mount	2
	5	33537	(070000–)	Bumber, Side, R.H.	1
	6	33536	(070000–)	Bumper, Side, L.H.	1
	7	05236	(070000–)	Bar, Hinge Long	2
	8	05223	(070000–)	Bar, Hinge Short	2
	9	05272	(070000–)	Spacer, Hinge	4
	10	33407	(070000–)	Block, Corner Frame	2
	11	05073	(070000–)	Bumper, Front	1
	12	05573	(070000–)	Cover, Rear	1

Fig. 4 – Main Frame Group

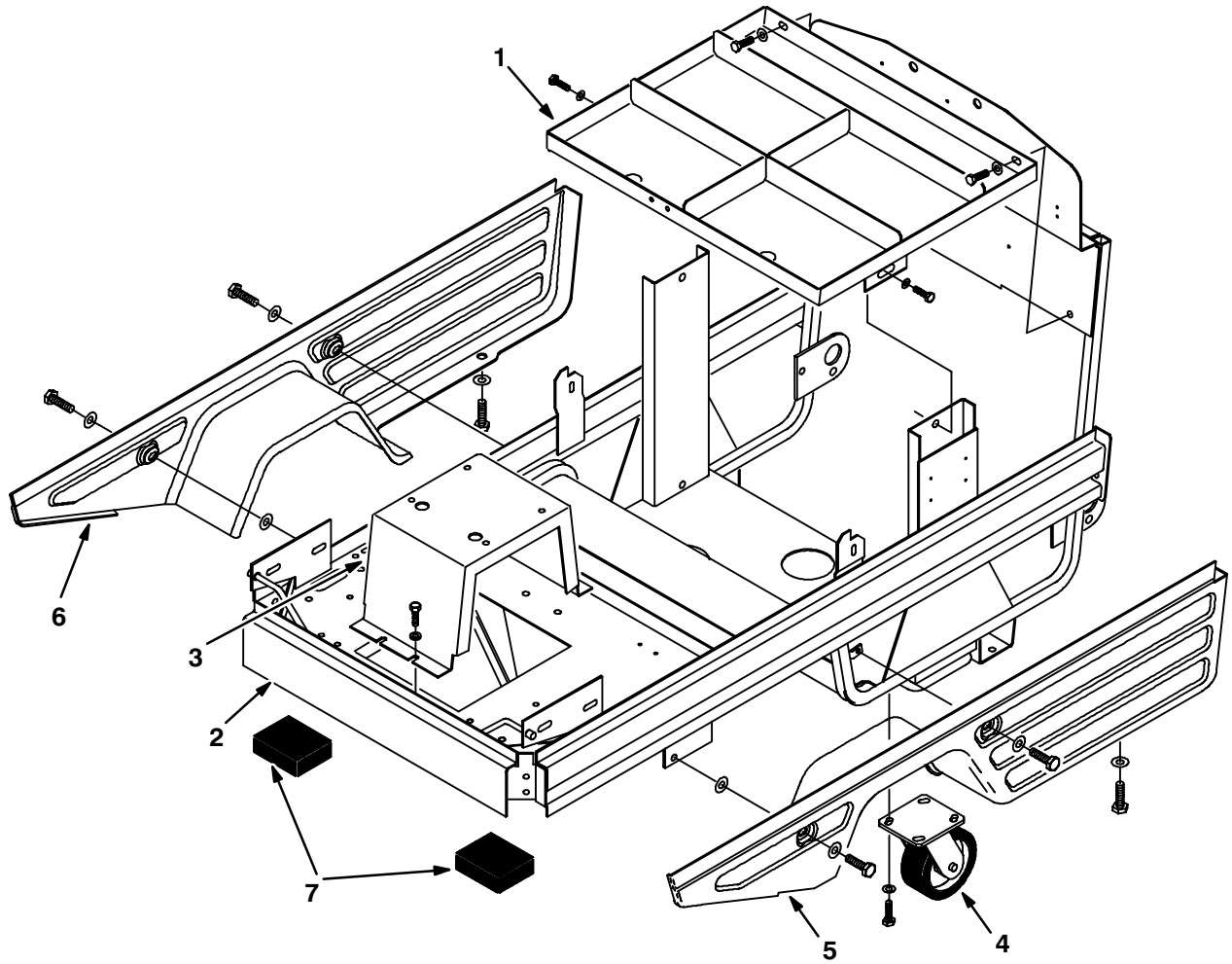

Fig. 4 – Main Frame Group

Ref.	Tennant Part No.	Machine Serial Number	Description	Qty.
1	28163	(070000–) Tray, Battery	1
2	33419	(070000–) Frame, Main	1
3	33416	(070000–) Channel	1
4	65690	(070000–) Caster	2
5	24931	(070000–) Panel, Cover, L.H.	1
6	24932	(070000–) Panel, Lower, R.H.	1
7	04702	(070000–) Pad, Head Stop	2

Fig. 5 – Front Shroud Group

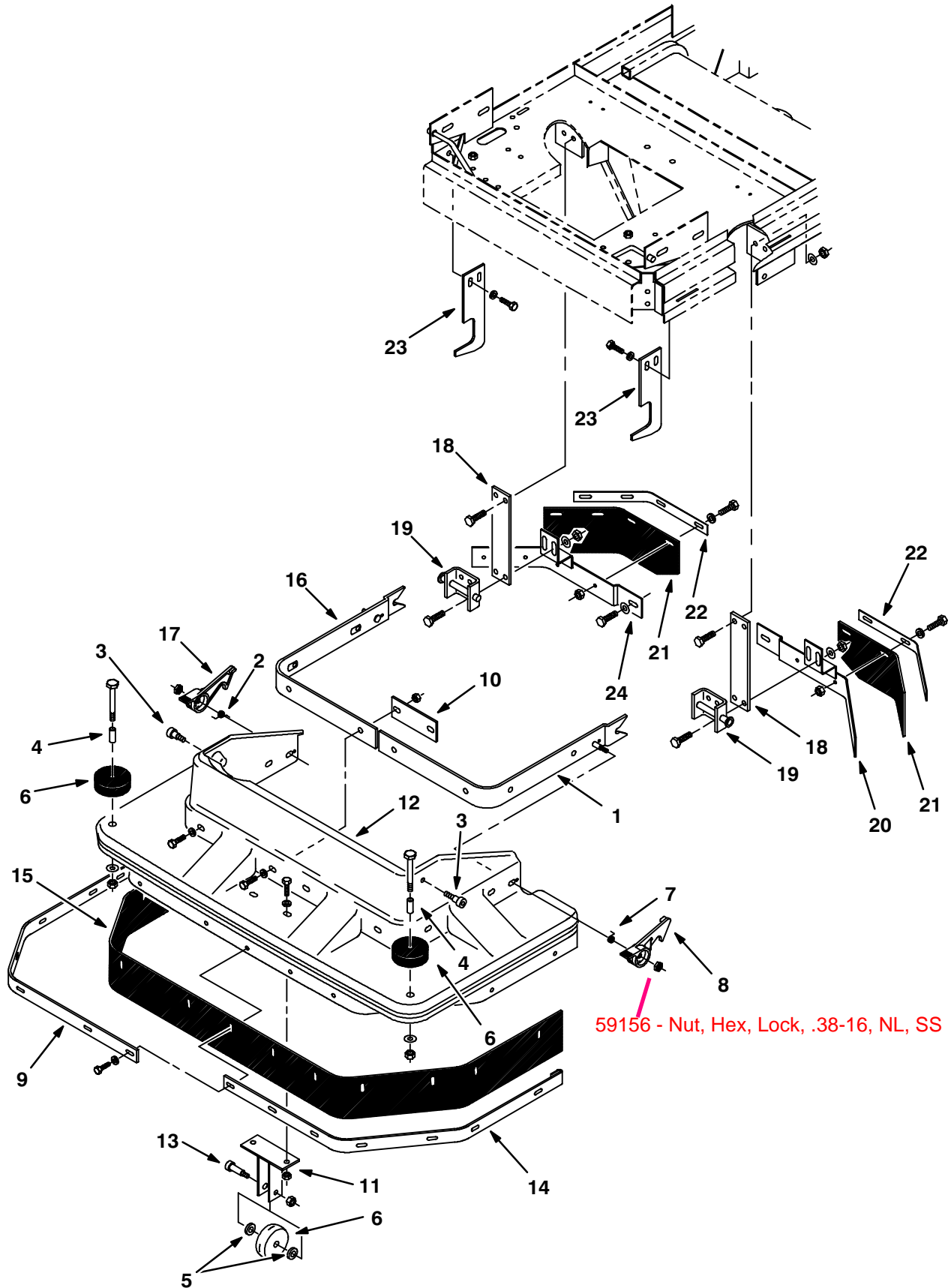

Fig. 5 – Front Shroud Group

Ref.	Tennant Part No.	Machine Serial Number	Description	Qty.	
▽	28498	(070000–) Scrub Shroud Replacement Kit	1	
▲ 1	28493	(070000) Strap, Shroud, L.H.	2	
▲ 2	10928	(070000–) Spring, Torsion, R.H.	1	
▲ 3	36758	(070000–) Screw, Shoulder	2	
▲ 4	33427	(070000–) Sleeve	2	
▲ 5	59633	(070000–) Bearing, Thrust, Fiberglide	2	
▲ 6	86800	(070000–) Wheel	3	
▲ 7	10927	(070000–) Spring, Torsion, L.H.	1	
▲ 8	11613	(070000–) Latch, Shroud, L.H.	1	
▲ 9	28489	(070000–) Strip, Skirt Retainer, R.H.	1	
▲ 10	28542	(070000–) Plate	1	
▲ 11	28545	(070000–) Bracket, Wheel	1	
▲ 12	28415	(070000–) Panel, Scrub Shroud Mounting	1	
▲ 13	86791	(070000–) Screw, Shoulder	1	
▲ 14	28470	(070000–) Strip, Skirt Retainer, L.H.	1	
▲ 15	28491	(070000–) Skirt, Scrub Head	1	
▲ 16	28465	(070000–) Strap, Shroud, R.H.	1	
▲ 17	11612	(070000–) Latch, Shroud, R.H.	1	
	18	06108	(070000–) Spring	2
	19	05214	(070000–) Bracket, Shroud Mounting	2
	20	24760	(070000–) Bracket, Skirt, L.H.	1
	21	24679	(070000–) Skirt, Side	2
	22	24796	(070000–) Strip, Backup	2
	23	24852	(070000–) Plate, Mount	2
	24	24785	(070000–) Bracket, Skirt, R.H.	1

Fig. 6 – Scrub Head Lift Group

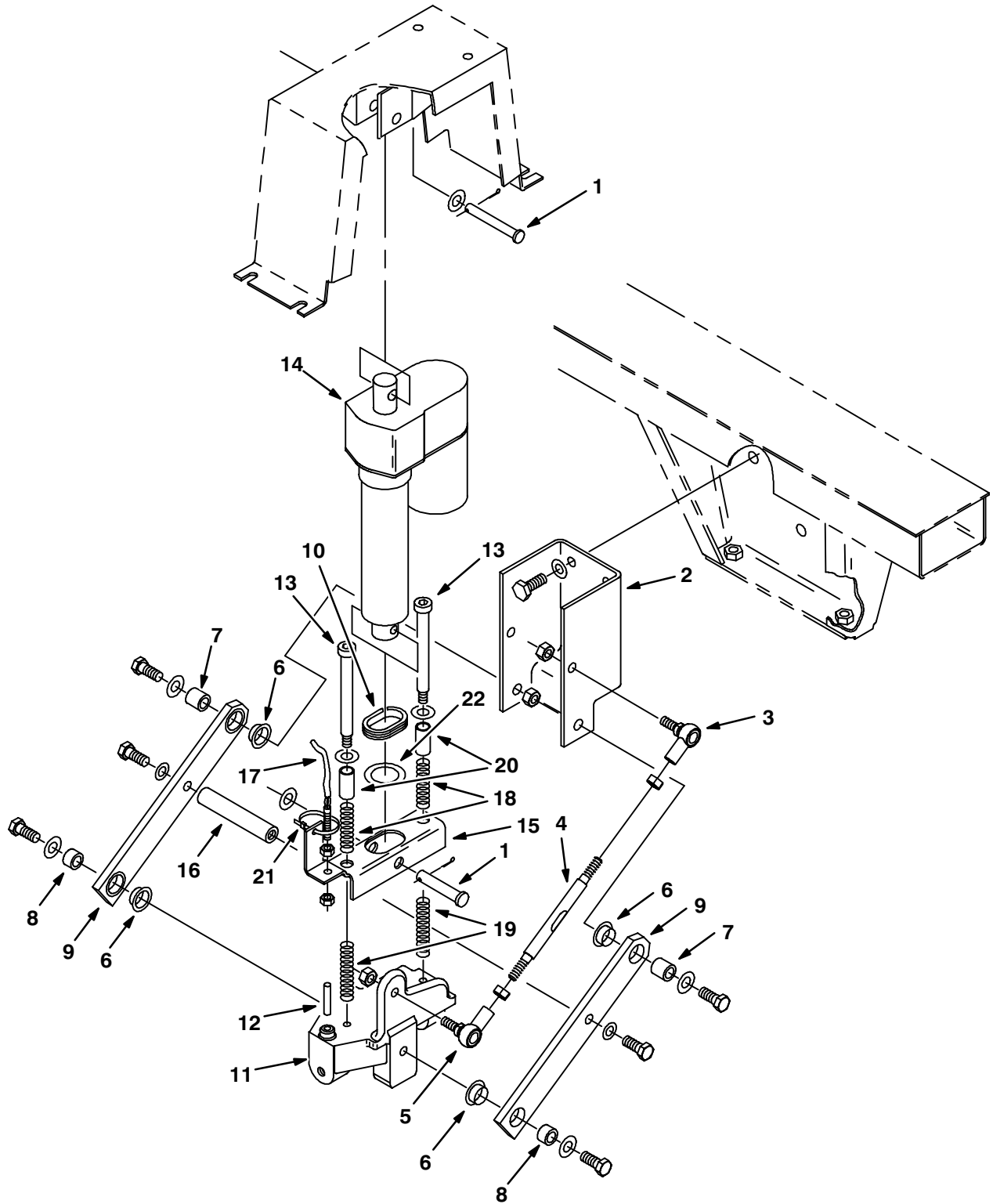
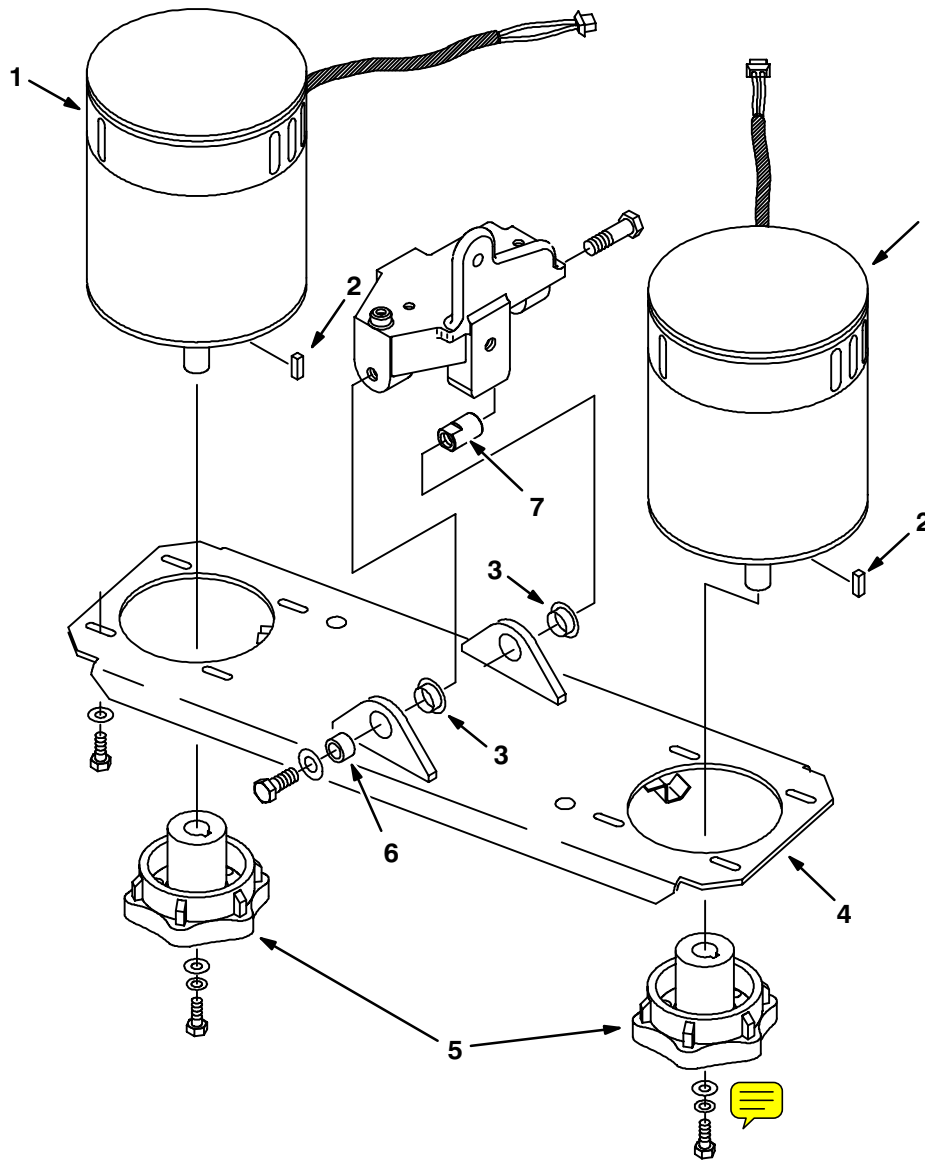

Fig. 6 – Scrub Head Lift Group

Ref.	Tennant Part No.	Machine Serial Number	Description	Qty.
1	51534	(070000–) Pin, Clevis	2
2	28434	(070000–) Bracket, Link Mount	1
3	05685	(070000–) Rod End, M10, L.H.	1
4	04921	(070000–) Rod, Adjusting	1
5	05686	(070000–) Rod End, M10, R.H.	1
6	04928	(070000–) Bearing, Flange	4
7	05019	(070000–) Sleeve	2
8	04927	(070000–) Sleeve	2
9	04920	(070000–) Bar, Pivot	2
10	10632–14	(070000–) Grommet	1
11	04924	(070000–) Pivot, Scrub Head	1
12	05735	(070000–) Magnet, Switch	1
13	45960	(070000–) Screw, Shoulder	2
14	05018	(070000–) Actuator, 36 V	1
15	28577	(070000–) Bracket, Head Lift	1
16	04942	(070000–) Spacer, Rod	1
17	28608	(070000–) Magnetic Reed Sensor Assembly	1
18	45261	(070000–) Spring	2
19	63185	(070000–) Spring	2
20	50682	(070000–) Sleeve	2
21	49266	(070000–) Tie Cable	1
22	27921	(070000–) Washer	1

Fig. 7 – Scrub Head Group



06273/06292

Ref.	Tennant Part No.	Machine Serial Number	Description	Qty.
1	04922	(070000–) Motor, 36 V (See Breakdowns)	2
2	00926	(070000–) Key, Square	2
3	04928	(070000–) Bearing, Flange	2
4	24578	(070000–) Plate, Brush Drive	1
5	14841	(070000–) Hub, Brush Drive	2
6	04927	(070000–) Sleeve	1
7	05612	(070000–) Sleeve, Scrub Head Rear	1

Fig. 8 – Tire and Rim Assembly

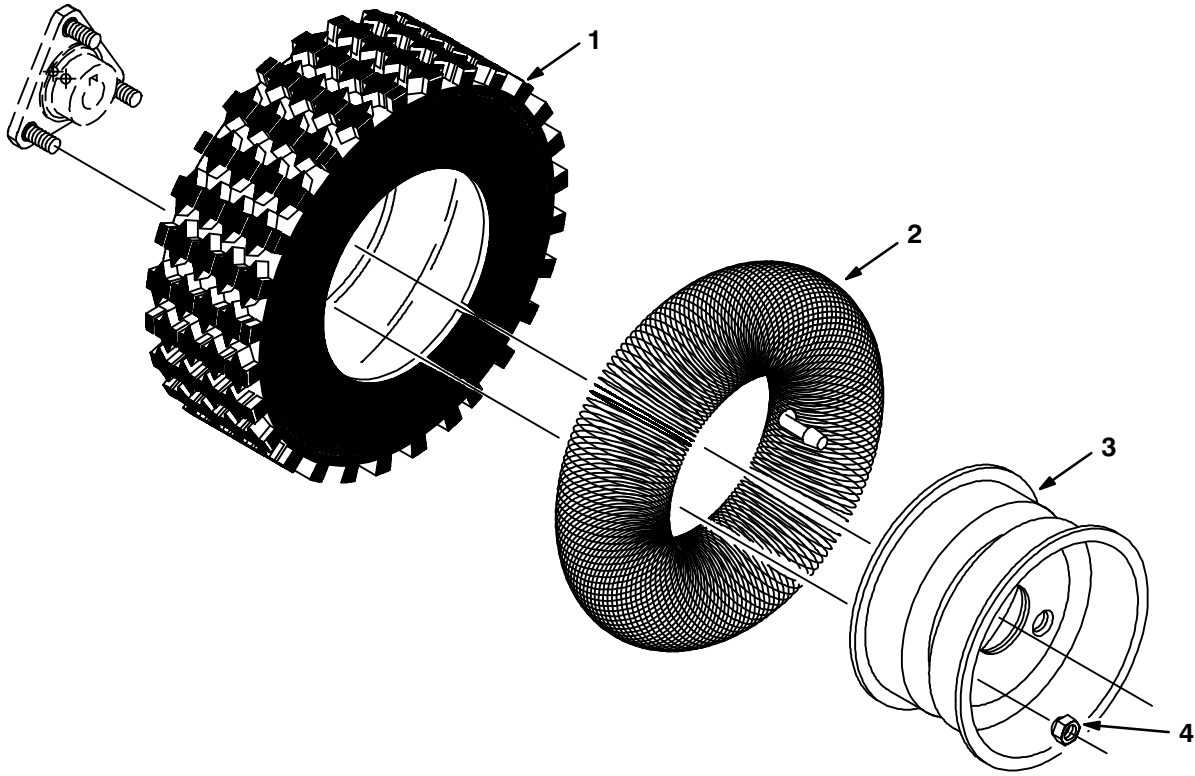

06274/04200

	Ref.	Tennant Part No.	Machine Serial Number	Description	Qty.
▽		61597	(070000–) Tire and Rim Assembly	2
▲	1	61596	(070000–) Tire, Non–marking	1
▲	2	04658	(070000–) Tube, Inner	1
▲	3	04657	(070000–) Rim	1
	4	11109	(070000–) Nut, Wheel	6

Fig. 9 – Dual Drive Group

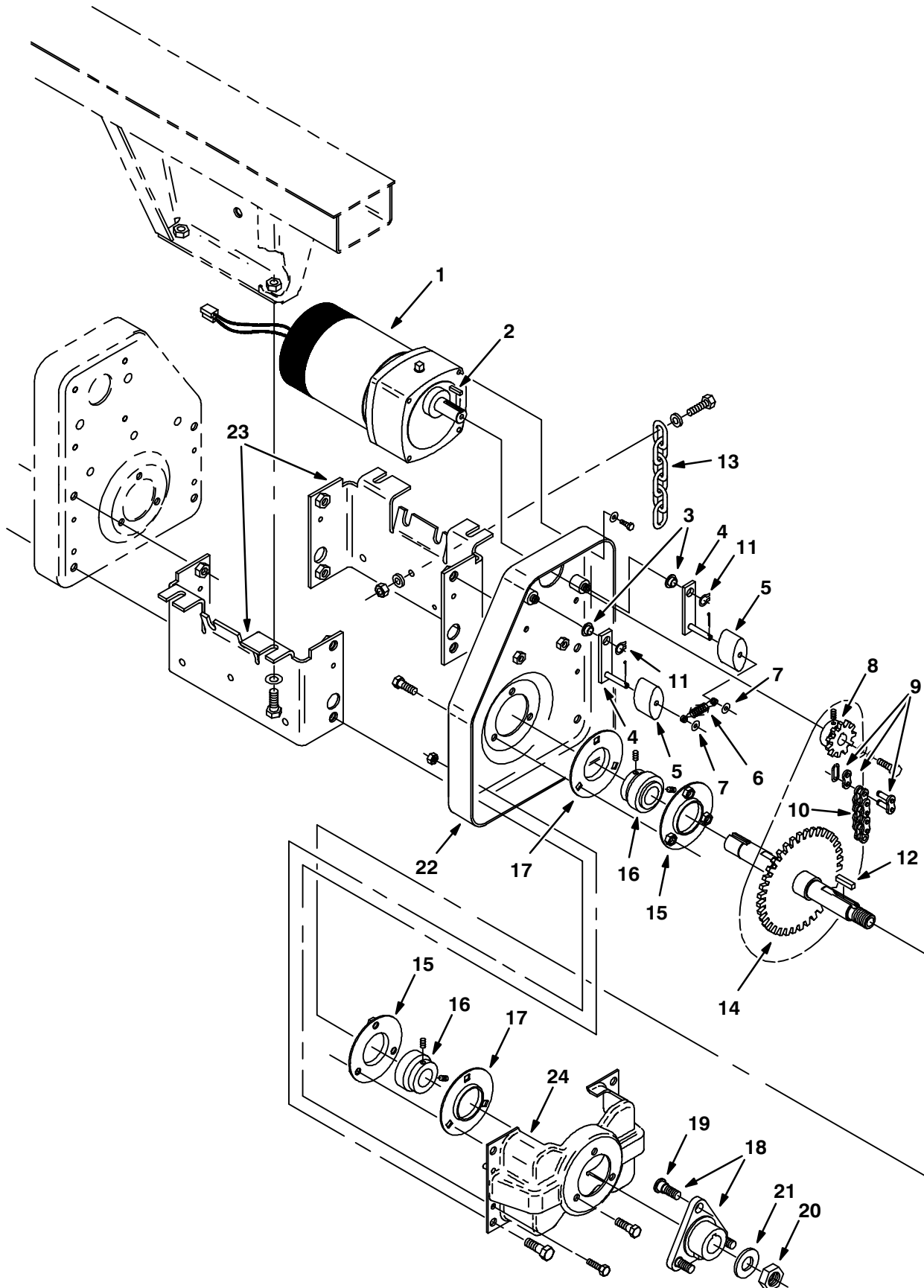

Fig. 9 – Dual Drive Group

Ref.	Tennant Part No.	Machine Serial Number	Description	Qty.
1	04656	(070000–) Motor (See Breakdowns)	2
2	00911	(070000–) Key, Square	2
3	15877	(070000–) Bearing, Flange	4
4	24547	(070000–) Arm, Chain Tension	4
5	04671	(070000–) Puck, Chain Tension	4
6	04720	(070000–) Spring, Compression	2
7	05604	(070000–) Wire, Spring	4
8	04672	(070000–) Sprocket	2
▽	9	61415	(070000–) Chain and Link Assembly	2
▲	10	28272	(070000–) Link, Roller Chain	1
11	24555	(070000–) E-Ring, External	4
12	00927	(070000–) Key, Square	2
13	47277)070000–) Chain, Static	1
14	33422	(070000–) Shaft and Sprocket	2
15	04746	(070000–) Flange, Bearing Retainer	4
16	24684	(070000–) Bearing Replacement Kit	4
17	36190	(070000–) Flange	4
▽	18	04704	(070000–) Dual Drive Hub Assembly	2
▲	19	11117	(070000–) Stud, Wheel	3
20	08169	(070000–) Nut, Nylon lock	2
21	04401	(070000–) Washer, M20	2
22	33446	(070000–) Housing, Chain	2
23	05572	(070000–) Bracket, Drive Mounting	2
24	11088	(070000–) Bracket, Bearing Support	2

Fig. 10 – Solution and Recovery Tanks Group

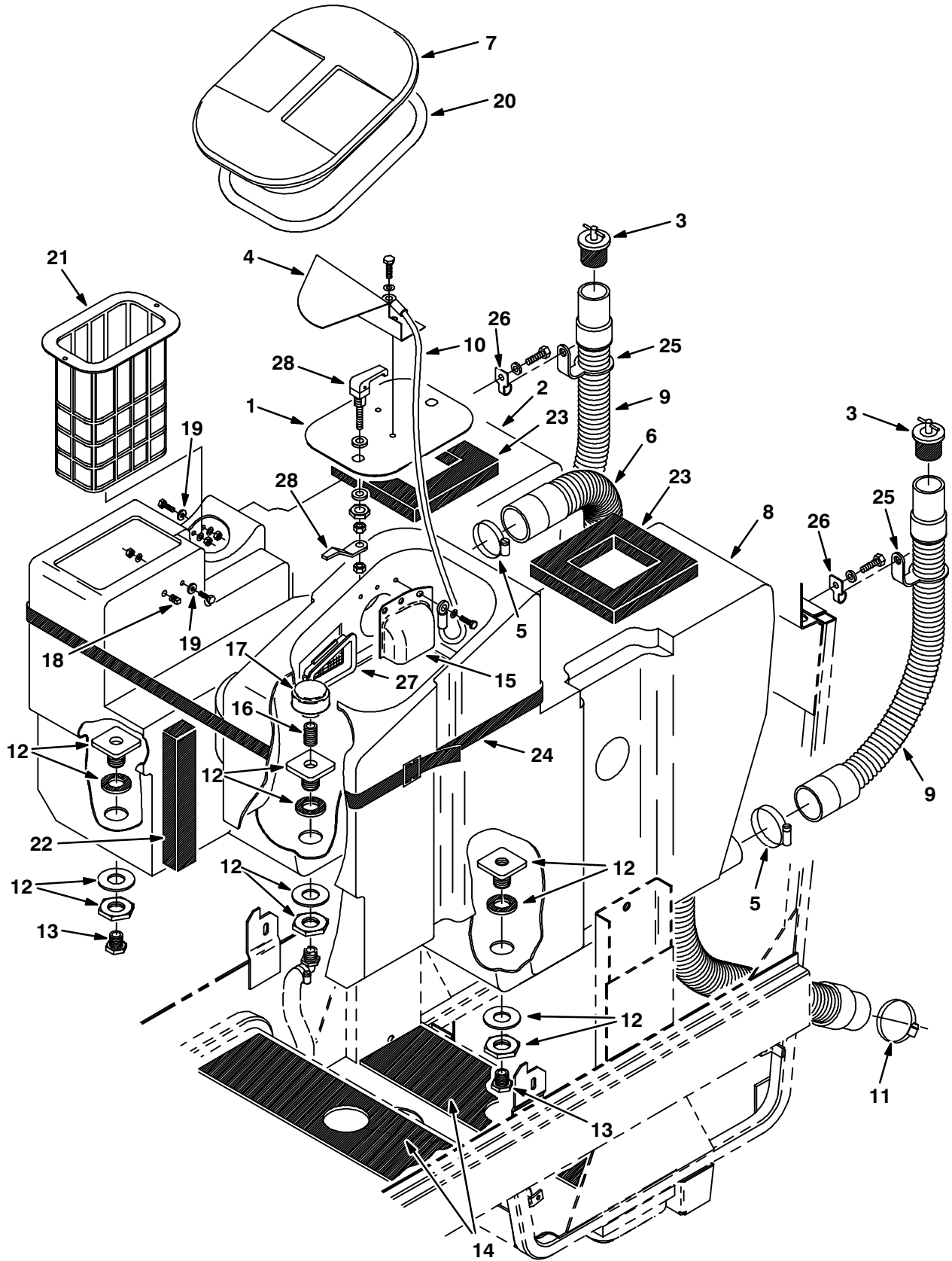

Fig. 10 – Solution and Recovery Tanks Group

Ref.	Tennant Part No.	Machine Serial Number	Description	Qty.
1	65552	(070000–070054)	Baffle Kit	1
1	65551	(070055–)	Plate, Baffle	1
2	05016	(070000–)	Tank, Solution	1
3	222396	(070000–)	Stopper Assembly	2
4	11746	(070000–)	Baffle, Tank	1
5	22297	(070000–)	Clamp, Worm Drive	3
6	05216	(070000–)	Hose, Squeegee	1
7	06137	(070000–)	Cover, Recovery Tank	1
8	05017	(070000–)	Tank Recovery	1
9	05127	(070000–)	Hose, Drain	2
10	19676	(070000–)	Lanyard	1
11	33344	(070000–)	Clamp, Worm Drive	1
12	65566	(070000–)	Fitting, Straight	3
13	75611	(070000–)	Fitting, Plug	2
14	05675	(070000–)	Pad, Tank	2
15	11750	(070000–)	Baffle, Vacuum Fan	1
16	69784	(070000–)	Fitting, Nipple	1
17	05218	(070000–)	Strainer, Solution Tank	1
18	56119	(070000–)	Fitting, Plug	1
19	76426	(070000–)	Washer, Sealing	3
20	05165	(070000–)	Seal, Recovery Tank Lid	1
21	43516A	(070000–)	Basket, Soap	1
22	04832	(070000–)	Pod, Foam	1
23	57828	(070000–)	Foam	2
24	04836	(070000–)	Strap, Poly	1
25	24663	(070000–)	Strap, Drain Hose	2
26	24638	(070000–)	Clip, Drain Hose	2
27	05089	(070000–)	Screen	1
28	65695	(070055–)	Latch, Lift and Turn, Adjustable	2

Fig. 11 – Vacuum Fan Group

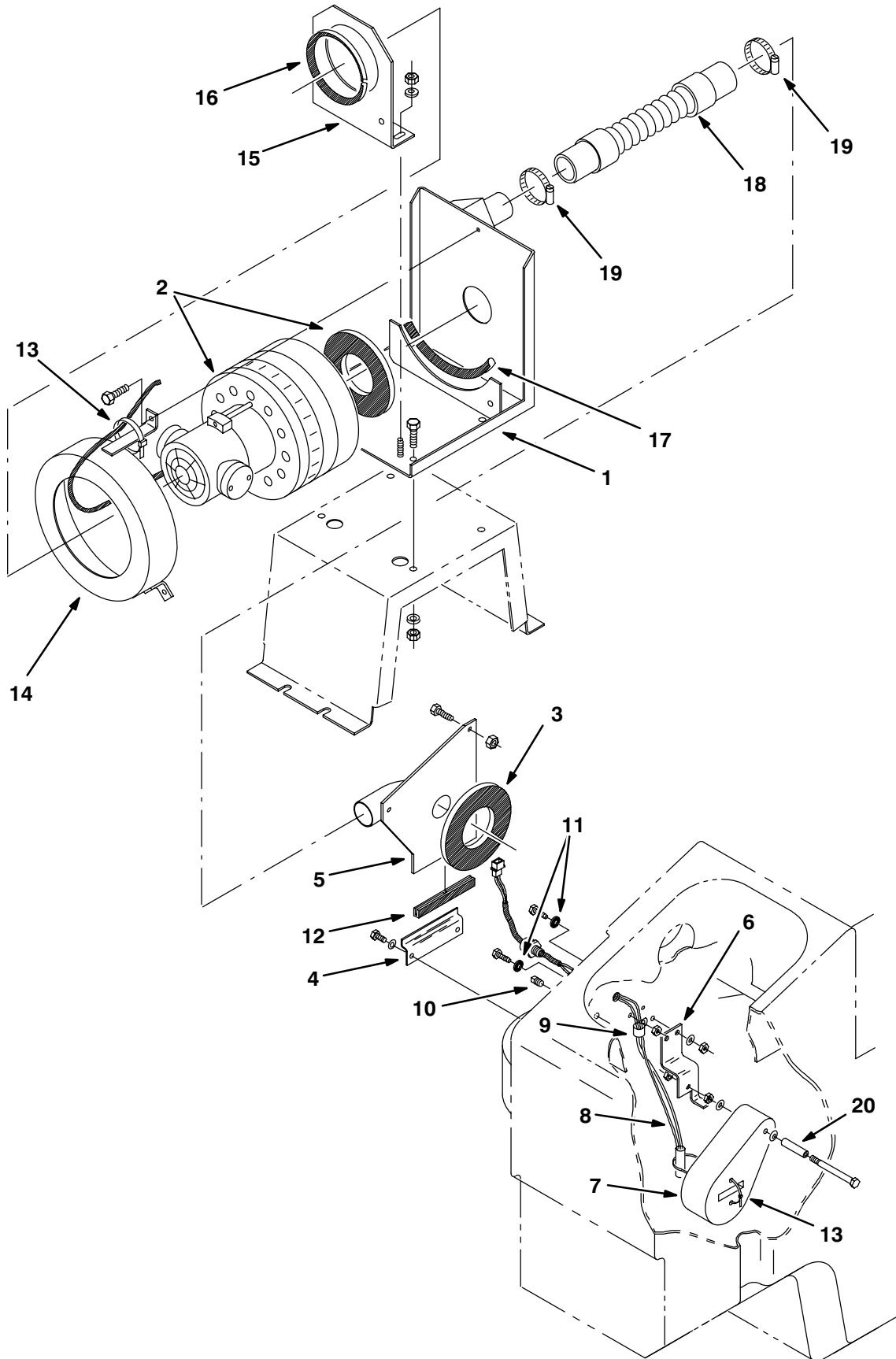

Fig. 11 – Vacuum Fan Group

Ref.	Tenant Part No.	Machine Serial Number	Description	Qty.
1	28400	(070000–) Bracket, Fan Mount	1
2	28386	(070000–) Fan, Vacuum	1
3	10912	(070000–) Seal	1
4	06146	(070000–) Bracket, Mounting	1
5	60171	(070000–) Plate and Label Assembly	1
6	05567	(070000–) Bracket, Water Level Control	1
7	65683	(070000–) Float, Water Level	1
8	28346	(070000–) Mercury Switch Assembly	1
9	33584	(070000–) Clamp, Cable	1
10	56119	(070000–) Fitting, Plug	1
11	76426	(070000–) Washer, Sealing	3
12	10911	(070000–) Isolator, Vacuum Fan	1
13	49266	(070000–) Tie, Cable	2
14	28405	(070000–) Ring, Fan	1
15	28410	(070000–) Bracket, Rear Fan Mount	1
16	28414	(070000–) Strip, Rubber	1
17	28413	(070000–) Strip, Rubber	1
18	28412	(070000–) Hose, Vacuum Fan	1
19	11531	(070000–) Clamp, Worm Drive	2
20	78551	(070000–) Tube	1

Fig. 12 – Solution Control Group

Ref.	Tennant Part No.	Machine Serial Number	Description	Qty.
1	43611	(070000–) Washer, Nylon	2
2	63342	(070000–) Sleeve	1
3	33438	(070000–) Lever, Control	1
4	33439	(070000–) Grip, Handle	1
5	27880	(070000–) Yoke Assembly	2
6	05670	(070000–) Cable, Push Pull	1
7	12083	(070000–) Water, Valve	1
8	05294	(070000–) Bracket, Valve Mounting	1
9	05669	(070000–) Arm, Water Valve	1
10	63244–1	(070000–) Fitting, Barbed Elbow	2
11	63244–3	(070000–) Fitting, Barbed Elbow	1
12	54333	(070000–) Clamp, Worm Drive	4
13	05714	(070000–) Hose, PVC	1
14	60164	(070000–) Hose, Clear Vinyl	1
15	05711	(070000–) Hose, Clear Vinyl	1
16	60165	(070000–) Hose, Clear Vinyl	1
17	63245–1	(070000–) Fitting, Barbed Tee	1

Fig. 13 – Battery Group

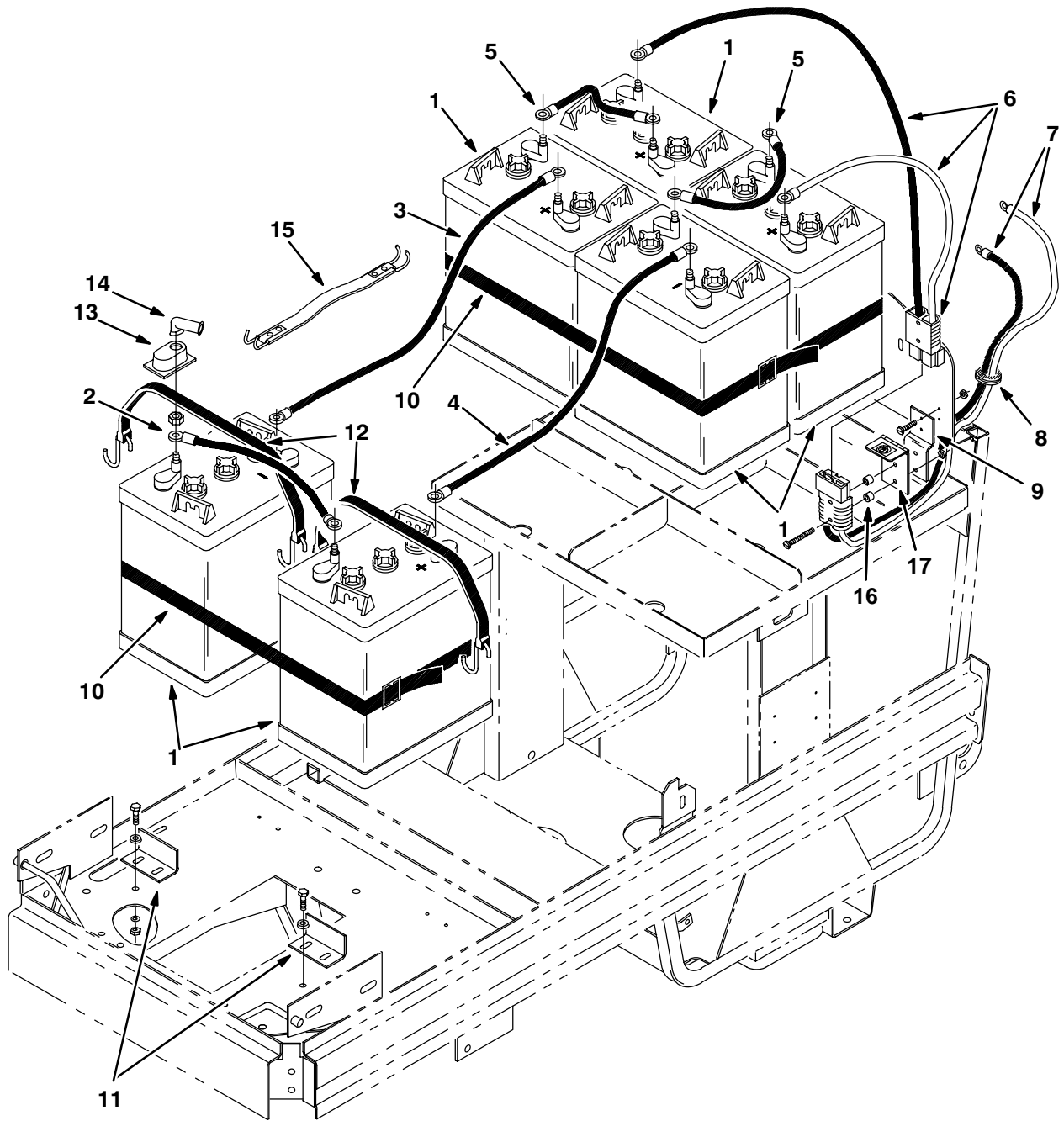

Fig. 13 – Battery Group

Ref.	Tennant Part No.	Machine Serial Number	Description	Qty.
1	10155	(070000–) Battery, 6 V, Wet	6
1	11229	(070000–) Battery, 6 V, Dry (International Only)	6
2	28333	(070000–) Cable, Battery	1
3	28334	(070000–) Cable, Battery	1
4	28335	(070000–) Cable, Battery	1
5	63740	(070000–) Cable, Battery	2
6	60096	(070000–) Harness, Battery Wire	1
7	60098	(070000–) Harness, Machine Wire	1
8	10632	(070000–) Grommet, Rubber	1
9	60095	(070000–) Bracket, Connector	1
10	04836	(070000–) Strap, Poly, Webbing	2
11	24843	(070000–) Angle, Battery Stop	2
12	33671	(070000–) Strap, Rubber, Tie-down	2
13	45962	(070000–) Cover, Terminal	12
14	02076	(070000–) Cover, Terminal	12
15	28286	(070000–) Strap, Battery Lift	1
16	01275	(070000–) Sleeve	2
17	65745	(070000–) Hinge, W/Label, SB175	1

Fig. 14 – Steering Control Group

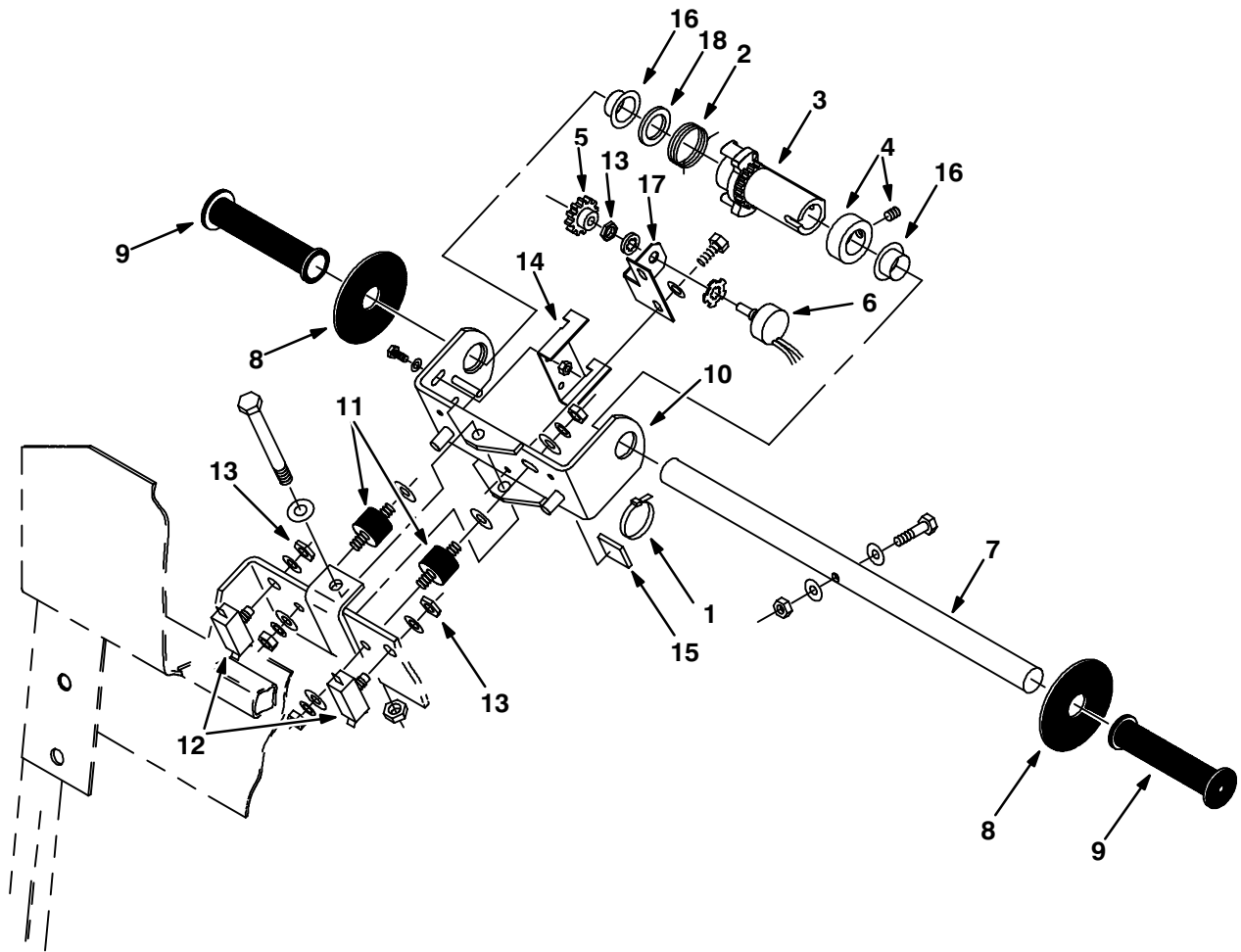

Fig. 14 – Steering Control Group

Ref.	Tennant Part No.	Machine Serial Number	Description	Qty.
1	49266	(070000–) Tie, Cable	8
2	04762	(070000–) Spring, Torsion Centering	1
3	04763	(070000–) Hub and Gear	1
4	04766	(070000–) Collar, Shaft	1
5	27974	(070000–) Gear	1
6	27957	(070000–) Potentiometer Replacement Kit	1
7	04760	(070000–) Handle, Speed Control	1
8	06208	(070000–) Washer	2
9	04765	(070000–) Grip, Handle	2
10	27934	(070000–) Bracket, Handle	1
11	05611	(070000–) Isolator, Vibration	2
12	63846	(070000–) Switch, Push Button	2
13	86730	(070000–) Nut, Hex, Thin	3
14	04767	(070000–) Stop, Spring	1
15	55248	(070000–) Mount, Cable Tie	5
16	27937	(070000–) Bearing, Flange	2
17	27973	(070000–) Bracket, Potentiometer	1
18	82226	(070000–) Washer	1

Fig. 15 – Rear Electrical Panel Group

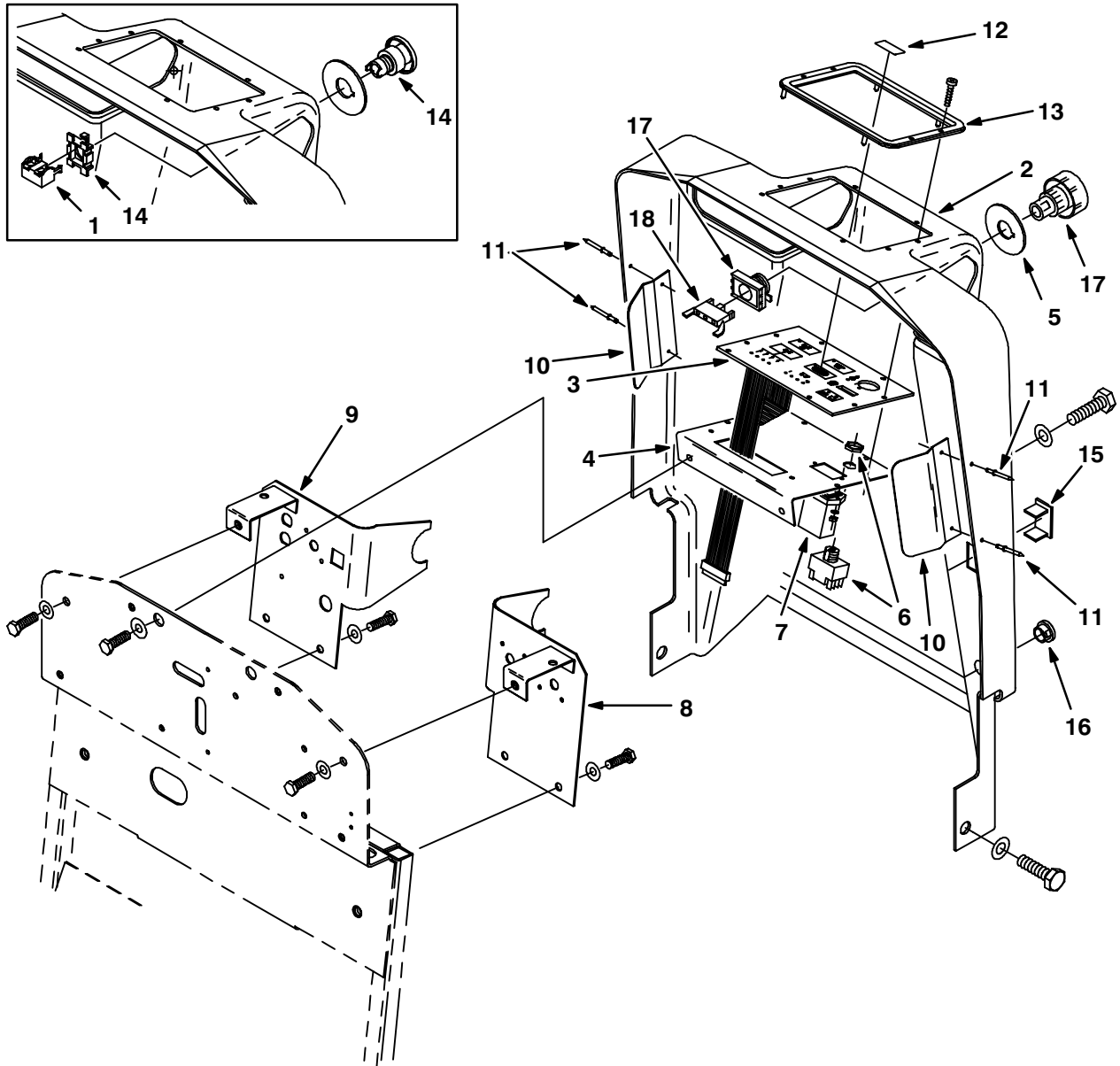
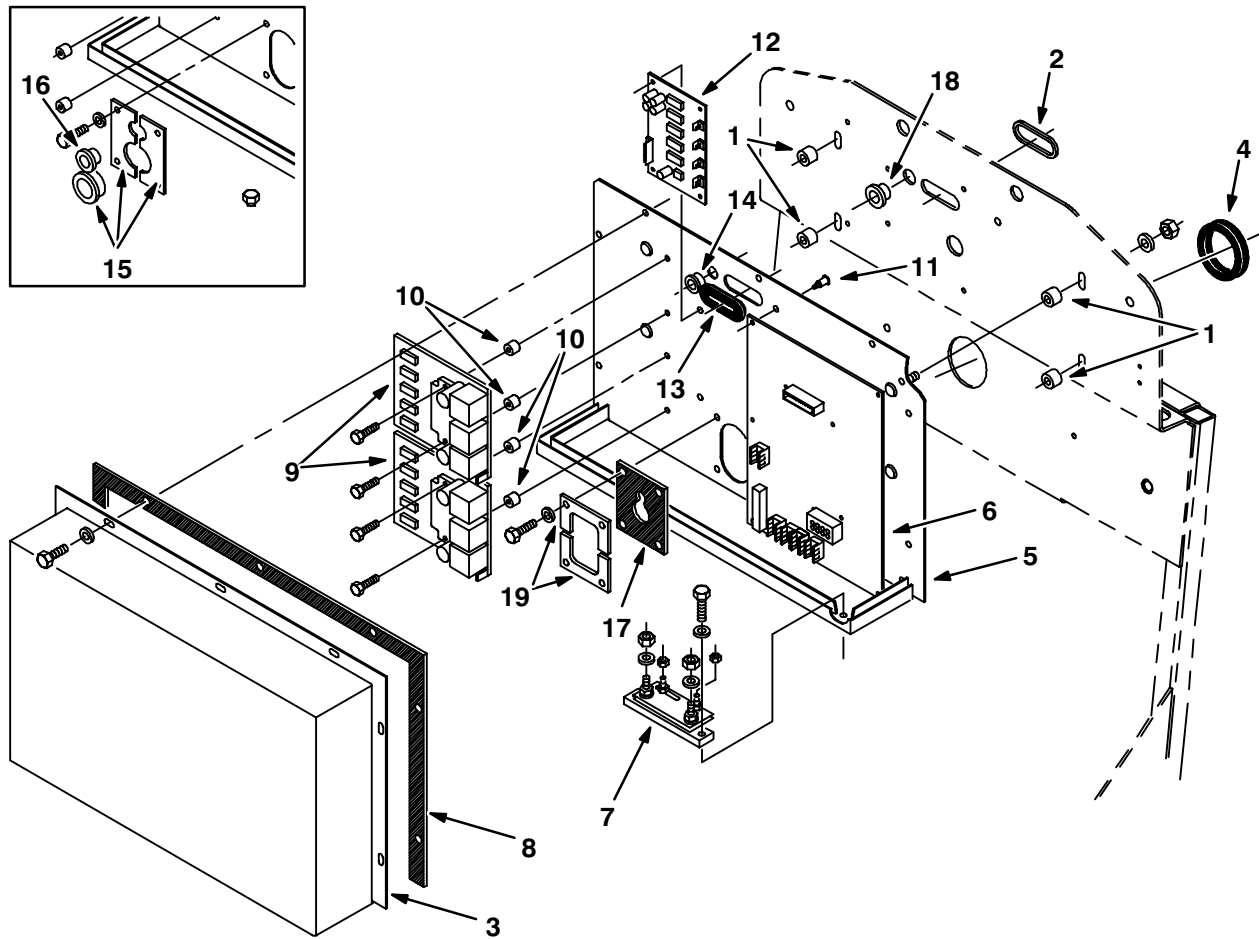

Fig. 15 – Rear Electrical Panel Group

Ref.	Tenant Part No.	Machine Serial Number	Description	Qty.	
1	11608	(070000–070058)	Contacts, Switch	2	
2	65598	(070000–)	Panel and Label Assembly, Rear	1	
3	65565	(070000–)	Panel, Touch Switch	1	
4	33470	(070000–)	Bracket, Touch Panel	1	
5	28428	(070000–)	Plate, Stop Button	1	
▽	6	31203	(070000–)	Key Switch Assembly	1
▲	31204	(070000–)	Key, Switch	1	
7	31988	(070000–)	Hourmeter	1	
8	04957	(070000–)	Plate, Circuit Breaker Mounting	1	
9	28416	(070000–)	Plate, Circuit Breaker Mounting	1	
10	05027	(070000–)	Guide, Cover, Rear	2	
11	56799	(070000–)	Rivet, Pop	4	
12	11744	(070000–)	Label, ES™ Cover	1	
13	33492	(070000–)	Bezel, Touch Panel	1	
14	28429	(070000–070058)	Switch, Push Button	1	
15	57772	(070000–)	Plate, Cover	1	
16	65584	(070000–)	Plugbutton	1	
17	65664	(070059–)	Switch, Push Button	1	
18	65665	(070059–)	Contacts, Switch	1	

Fig. 16 – Electrical Controller Group



06282/04777

Ref.	Tennant Part No.	Machine Serial Number	Description	Qty.
1	40282	(070000–)	Sleeve	4
2	11708	(070000–)	Grommet, Flexible	1
3	27951	(070000–)	Cover and Label Kit, Electric Panel	1
4	10632–19	(070000–)	Grommet	1
5	27941	(070000–)	Panel, Electric	1
6	27960	(070000–)	Control Board Kit	1
7	10973	(070000–)	Shunt	1
8	27945	(070000–)	Gasket, Electric Panel	1
9	27961	(070000–)	Controller Kit, Dual	2
10	65742	(070000–)	Sleeve	4
11	15840	(070000–)	Pin, Prong	14
12	27962	(070000–)	Board Kit, Interface Steering	1
13	27928	(070000–)	Grommet, Ribbon Cable	1
14	27947	(070000–)	Grommet	1
15	28341	(070000–070005)	Grommet Replacement Kit	2
16	27948	(070000–070005)	Grommet	1
17	27915	(070006–)	Grommet, Harness	1
18	27948	(070000–)	Grommet	1
19	27914	(070006–)	Plate, Harness	2

Fig. 17 – Rear Electrical Group

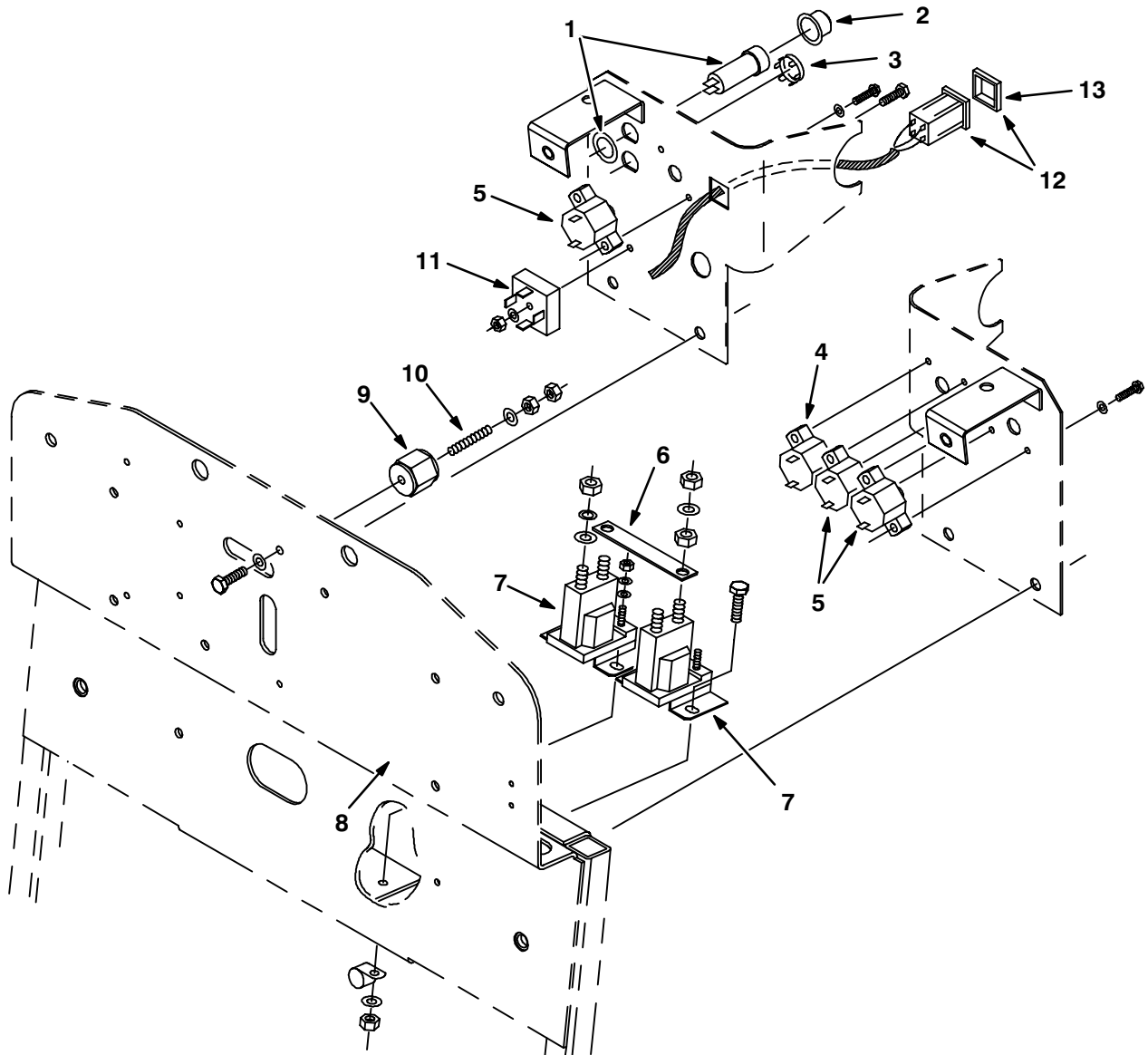

06283/06310

Ref.	Tenant Part No.	Machine Serial Number	Description	Qty.	
1	27920	(070000–)	Breaker, Circuit, 5 A	1	
2	57751	(070000–)	Boot, Circuit Breaker	2	
3	57167	(070000–)	Plugbutton	1	
4	27969	(070000–)	Breaker, Circuit, 35 A	1	
5	63030–2	(070000–)	Breaker, Circuit, 25 A	3	
6	10967	(070000–)	Busbar, Relay	1	
7	04685	(070000–)	Contactor	2	
8	26395–1	(070000–)	Clamp, Cable	1	
9	76062	(070000–)	Insulator, Panel and Switchboard	1	
10	41702	(070000–)	Rod, Threaded	1	
11	10962	(070000–)	Diode, Bridge, 12 A	1	
▽	12	28396	(070000–)	Switch and Harness Assembly	1
▲	13	28398	(070000–)	Seal, Switch	1

Fig. 18 – Rear Squeegee Link Group

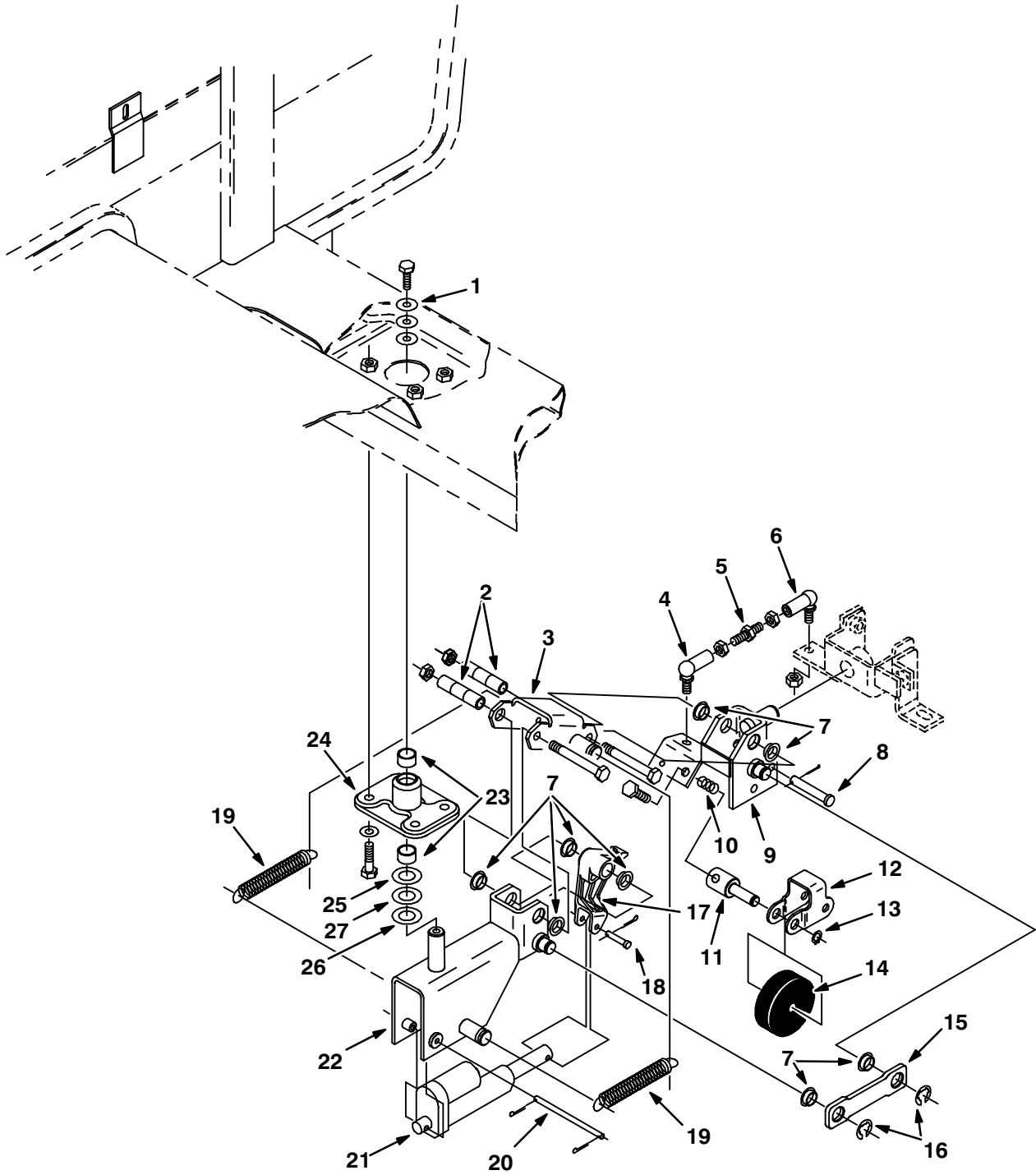
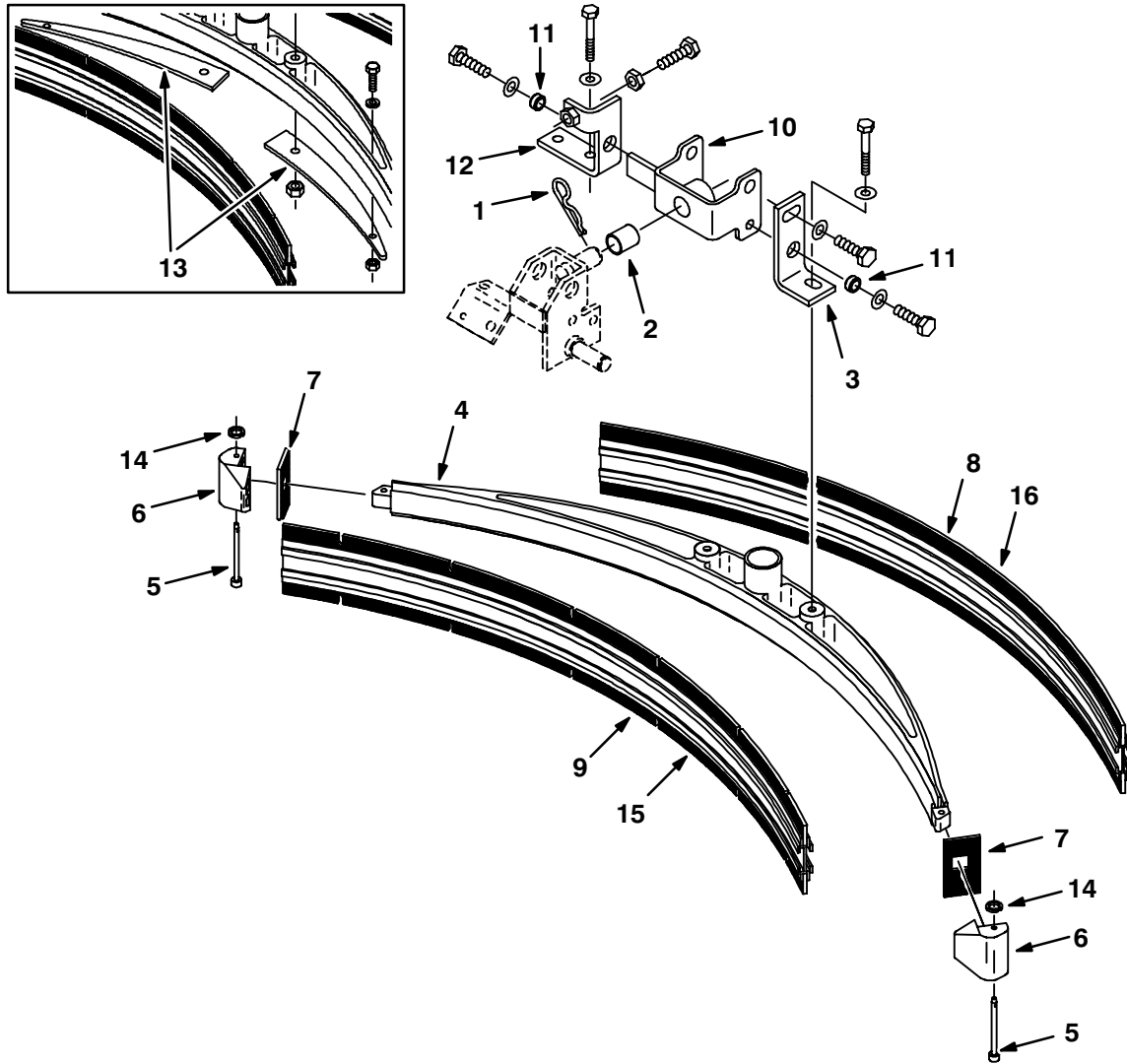

Fig. 18 – Rear Squeegee Link Group

Ref.	Tennant Part No.	Machine Serial Number	Description	Qty.
1	05624	(070000–) Washer	1
2	05145	(070000–) Sleeve, Squeegee Lift	2
3	33362	(070000–) Bracket, Squeegee Lift	1
4	82962	(070000–) Ball Joint, L.H.	1
5	24926	(070000–) Stud, Adjustment	1
6	63282	(070000–) Ball Joint, R.H.	1
7	04843	(070000–) Bearing, Flange	8
8	33355	(070000–) Pin, Clevis	1
9	33348	(070000–) Bracket, Squeegee Lift	1
10	33498	(070000–) Spring	1
11	33379	(070000–) Axle, Caster Adjustment	1
12	33499	(070000–) Bracket, Caster	1
13	05284	(070000–) Clip, Retainer	1
14	86800	(070000–) Wheel	1
15	33371	(070000–) Link, Connecting	1
16	33373	(070000–) Ring, Retaining	2
17	04845	(070000–) Arm, Lift	1
18	05283	(070000–) Pin, Clevis	1
19	33395	(070000–) Spring, Tension	2
20	33391	(070000–) Pin, Actuator	1
21	48679	(070000–) Actuator	1
22	33388	(070000–) Bracket, Pivot, Squeegee	1
23	64377	(070000–) Bearing, Journal	2
24	05099	(070000–) Flange, Squeegee	1
25	04846	(070000–) Washer, Thrust	1
26	64489	(070000–) Washer	1
27	40847–1	(070000–) Shim	–

Fig. 19 – Rear Squeegee Group



06285/06297

Ref.	Tennant Part No.	Machine Serial Number	Description	Qty.	
1	55094	(070000–)	Pin, Hair Cotter	1	
2	04844	(070000–)	Bearing, Journal	1	
3	04808	(070000–)	Bracket, Adjustment, L.H.	1	
4	65684	(070000–)	Body, Squeegee	1	
5	33403	(070000–)	Pin, Clevis	2	
6	04752	(070000–)	Bumper, Squeegee	2	
∇	33475	(070000–)	Squeegee Blade Kit	1	
▲	7	11283	(070000–)	Blade, Squeegee End	2
▲	8	33590	(070000–)	Squeegee Blade Assembly, Rear	1
▲	9	33588	(070000–)	Squeegee Blade Assembly, Front	1
10	04809	(070000–)	Bracket, Squeegee Mount	1	
11	33369	(070000–)	Sleeve, Squeegee	2	
12	24919	(070000–)	Bracket, Adjuster, R.H.	1	
13	28501	(070000–xxxxx)	Plate, Support (replaced by none)	2	
14	49708	(070000–)	Ring, Split	2	
15	78548	(070000–)	Squeegee Blade Assembly, Front, Urethane	1	
16	78549	(070000–)	Squeegee Blade Assembly, Rear, Urethane	1	

Fig. 20 – Label Group

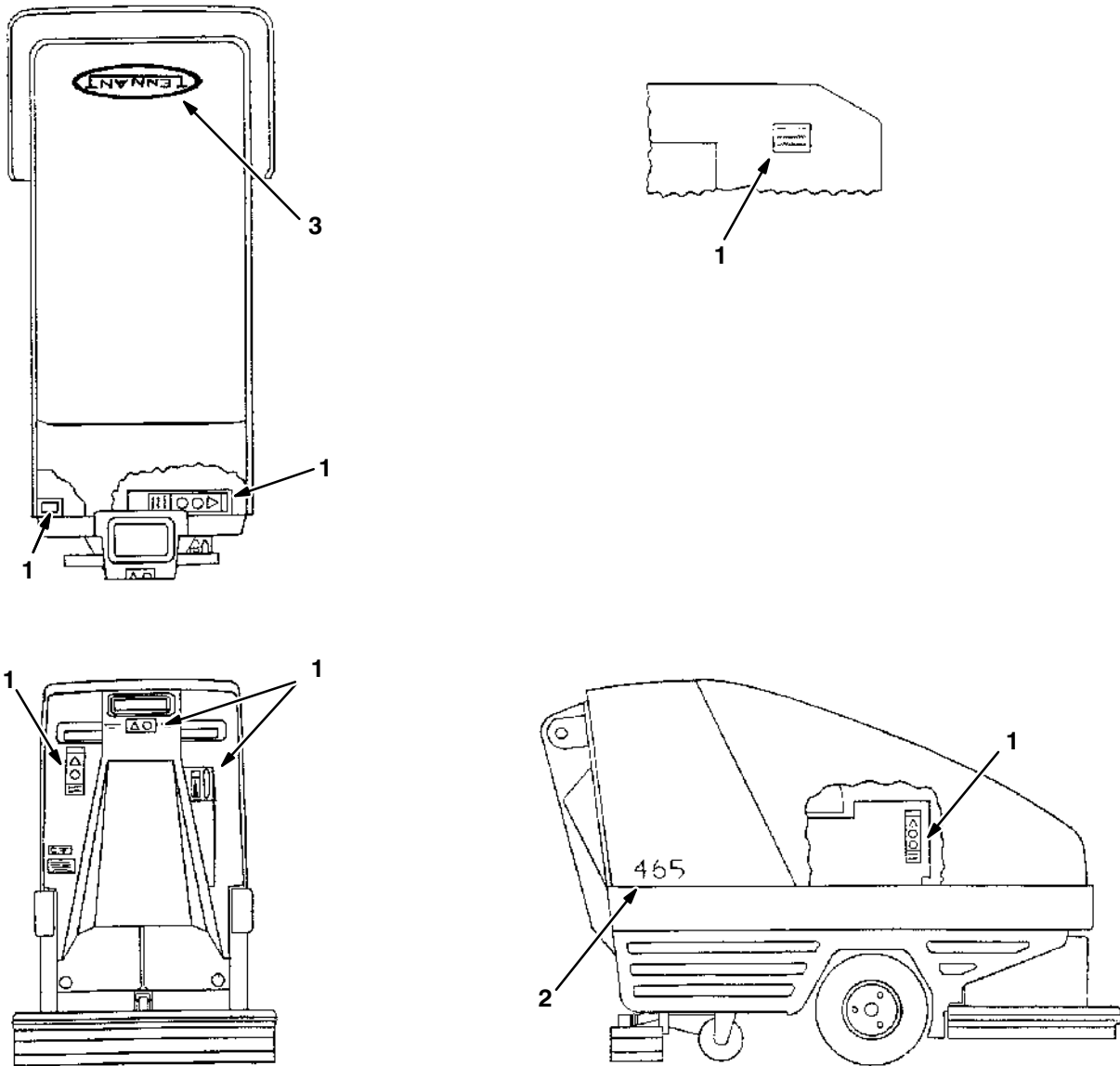

06286/05098

Ref.	Tennant Part No.	Machine Serial Number	Description	Qty.
1	11541	(070000–) Label Set, Information and Hazard	1
2	65608	(070000–) Label, Numerals 1490	2
3	86877	(070000–) Label, TENNANT Logo, White	1

Fig. 21 – Wire Harness Group

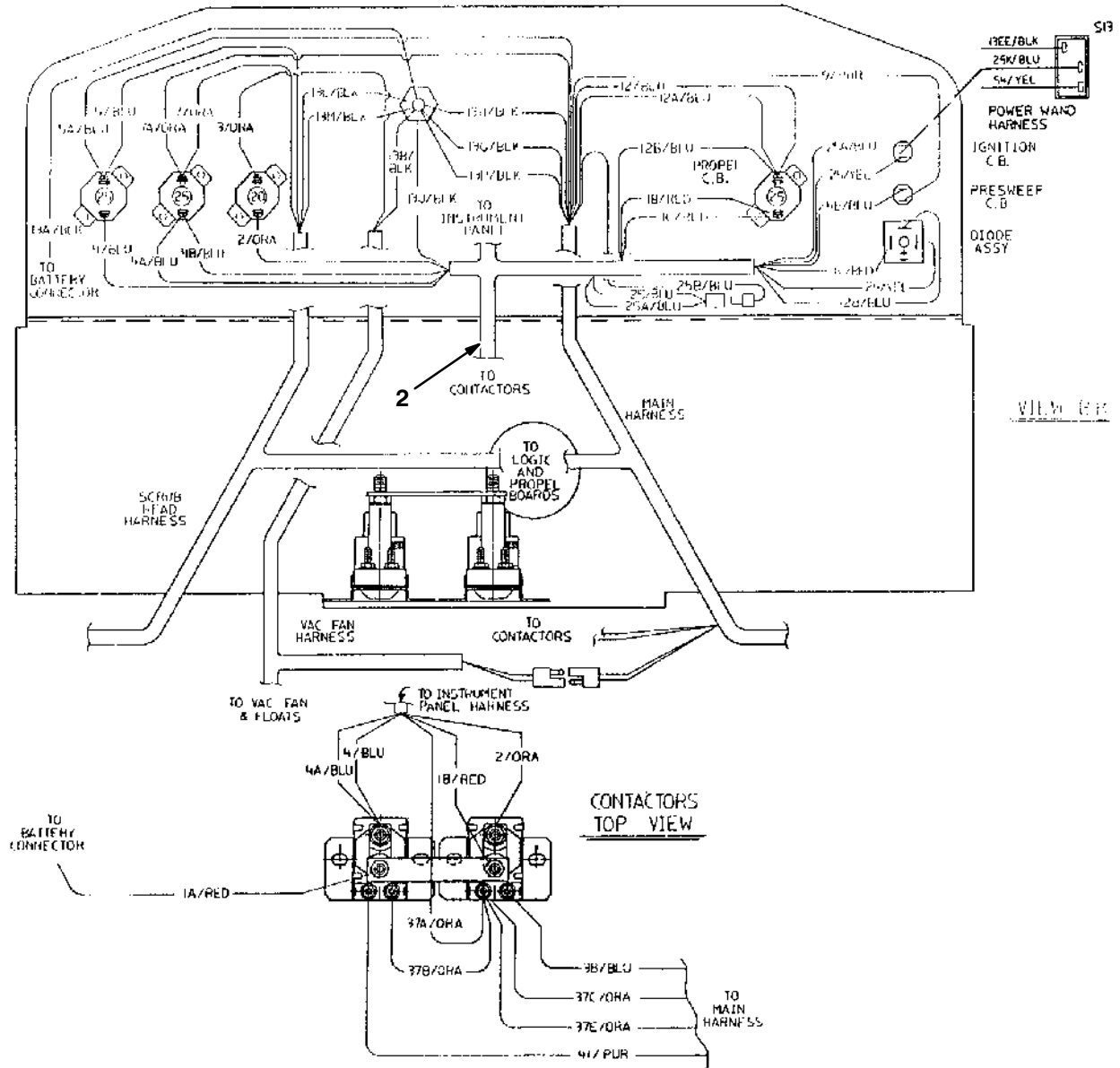

06287/05212

Ref.	Tennant Part No.	Machine Serial Number	Description	Qty.
1	28610	(070000—)	Harness, Wire, Main	1
2	05638	(070000—)	Harness, Instrument Panel	1
3	28347	(070000—)	Harness, Wire, Vacuum Fan	1
4	05639	(070000—)	Harness, Wire, Scrub Head	1
5	28336	(070000—)	Harness, Wire, Logic	1
6	05633	(070000—)	Harness, Wire, Power Steering	1
7	04693	(070000—)	Harness, Wire, Steering Switch	1
8	65697	(070000—)	Harness, Wire, Switch	1

SECTION 9

CONTENTS

	Page
Fig. 1 – Heavy Duty Bumper Kit, 1465	9-2
Fig. 2 – Heavy Duty Bumper Kit, 1465	9-3
Fig. 3 – Heavy Duty Bumper Kit, 1480	9-4
Fig. 4 – Heavy Duty Bumper Kit, 1480	9-5
Fig. 5 – Heavy Duty Bumper Kit, 1490	9-6
Fig. 6 – Demo Group, 1465	9-7
Fig. 7 – Demo Group, 1480	9-8
Fig. 8 – Demo Group, 1490	9-9
Fig. 9 – Vacuum Wand Kit	9-10
Fig. 10 – Pre-Sweep™ Mounting Group, 1465	9-12
Fig. 11 – Pre-Sweep™ Mounting Group, 1480	9-13
Fig. 12 – Pre-Sweep™ Drive Group, 1465	9-14
Fig. 13 – Pre-Sweep™ Drive Group, 1480	9-16
Fig. 14 – Pre-Sweep™ Frame Group, 1465	9-18
Fig. 15 – Pre-Sweep™ Frame Group, 1480	9-20
Fig. 16 – Extended Scrub Group, 1465	9-22
Fig. 17 – Extended Scrub Group, 1480	9-24
Fig. 18 – Extended Scrub Group, 1490	9-26
Fig. 19 – Wheel Cover Group	9-28
Fig. 20 – Foam Filled Tire Group	9-29
Fig. 21 – Dual Parking Brake Group	9-30
Fig. 22 – GS Group, 1465	9-32
Fig. 23 – GS Group, 1480	9-34
Fig. 24 – Battery Charger Group, 60 Hz (220 Ah batteries)	9-36
Fig. 25 – Battery Charger Group, 50 Hz (220 Ah batteries)	9-37
Fig. 26 – Battery Charger Group, 40A, 36V, 50 Hz (305 Ah batteries)	9-38
Fig. 27 – Battery Charger Group, 36A, 36V, 115V (305 Ah batteries)	9-39
Fig. 28 – Battery Charger Group, 60 Hz (220 Ah batteries)	9-40
Fig. 29 – Battery Charger Group, 50 Hz, 230V (220 Ah batteries)	9-41
Fig. 30 – Battery Charger Group, 50 Hz, 245V (220 Ah batteries)	9-41
Fig. 31 – Battery Charger Group, 60 Hz (305 Ah batteries)	9-42
Fig. 32 – Battery Charger Group, 50 Hz(305 Ah batteries)	9-43
Fig. 33 – Heavy Duty Battery Kit, Wet, 1480	9-44
Fig. 34 – Heavy Duty Battery Kit, Dry, 1480	9-45
Fig. 35 – Battery Tray Group, 1465	9-46
Fig. 36 – Battery Tray Group, 1480, 1490	9-47
Fig. 37 – Heavy Duty Battery Tray Group, 1480, 1490	9-48
Fig. 38 – Power Wand Hose Assembly	9-49
Fig. 39 – Power Wand Assembly	9-50
Fig. 40 – Power Wand Pump and Electrical Group	9-52
Fig. 41 – Power Wand Mount Group	9-54

Fig. 1 – Heavy Duty Bumper Kit, 1465

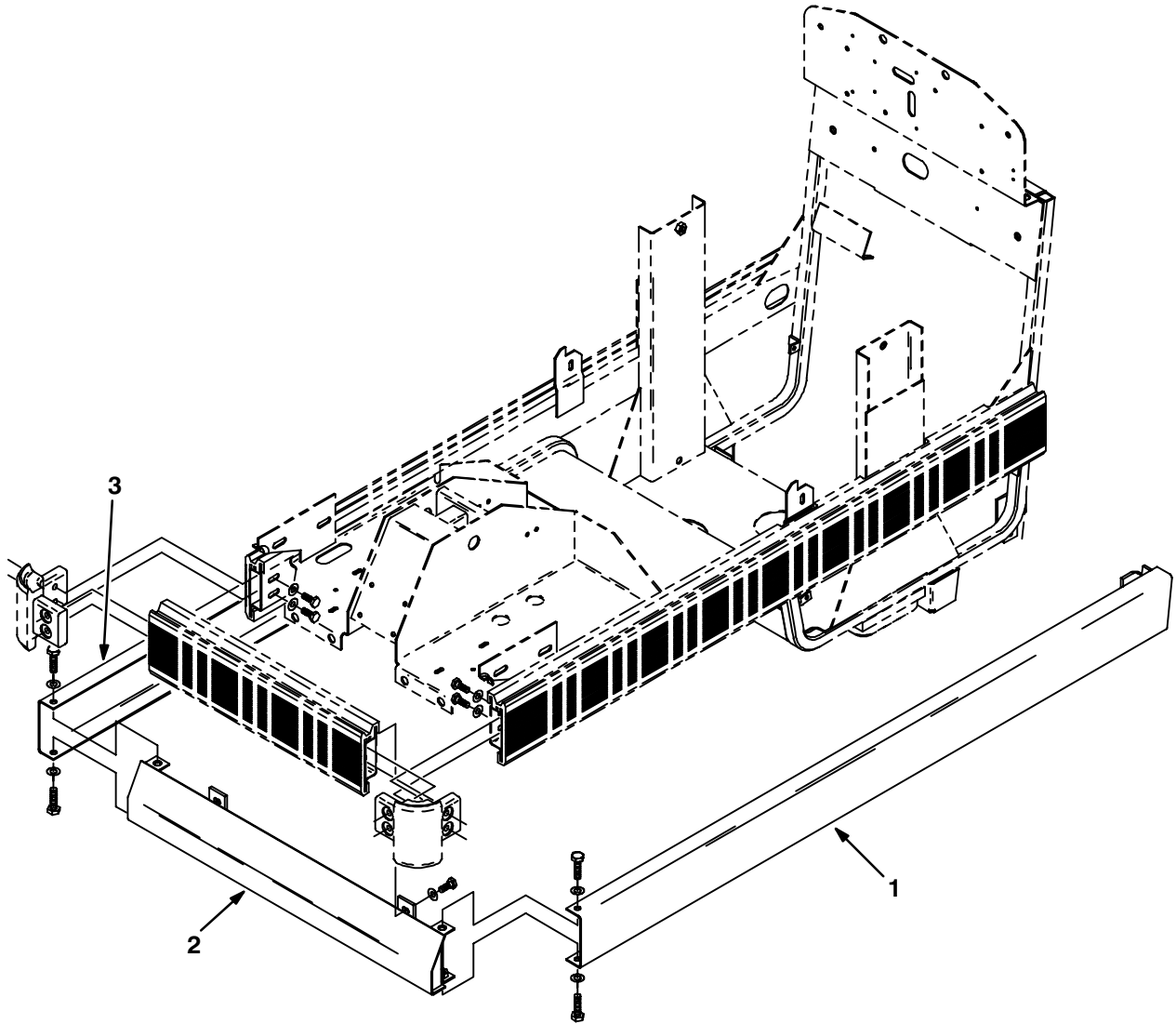

0617904209

Ref.	Tennant Part No.	Machine Serial Number	Description	Qty.
∇	05650	(030000–030172)	Heavy Duty Bumper Kit	1
▲	1 11647	(030000–030172)	Bumper, Heavy Duty, L.H.	1
▲	2 11643	(030000–030172)	Bumper, Front	1
▲	3 11648	(030000–030172)	Bumper, Heavy Duty, R.H.	1

Fig. 2 – Heavy Duty Bumper Kit, 1465

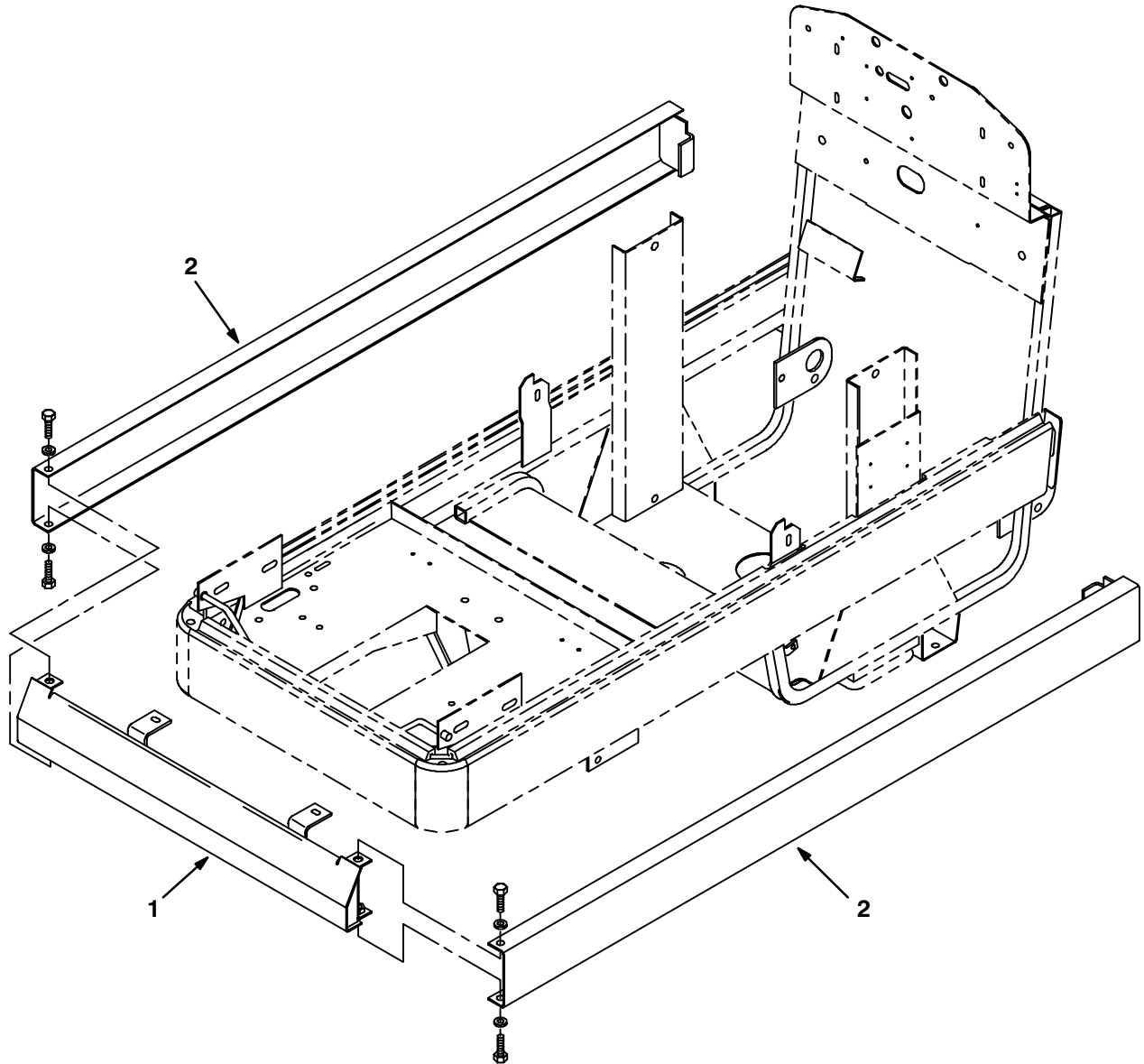

06150/06152

	Ref.	Tennant Part No.	Machine Serial Number	Description	Qty.
▽		24836	(030173–) Heavy Duty Bumper Kit	1
▲	1	24801	(030173–) Bumper, Front	1
▲	2	24942	(030173–) Bumper, Side Channel	2

Fig. 3 – Heavy Duty Bumper Kit, 1480

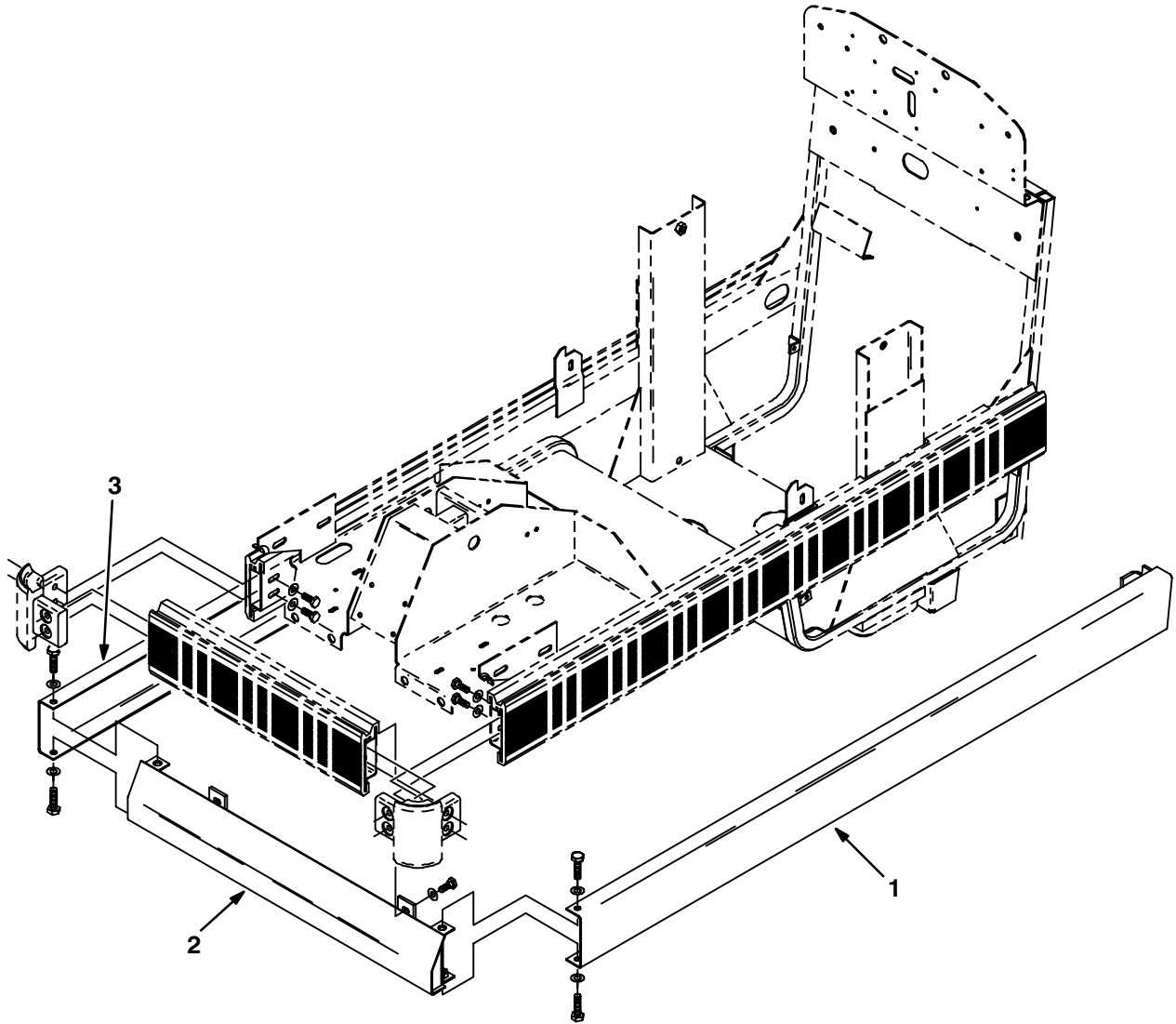

06180/04209

Ref.	Tennant Part No.	Machine Serial Number	Description	Qty.
▽	11467	(040000–040469)	Heavy Duty Bumper Kit	1
▲	1 11647	(040000–040469)	Bumper, Heavy Duty, L.H.	1
▲	2 11644	(040000–040469)	Bumper, Front	1
▲	3 11648	(040000–040469)	Bumper, Heavy Duty, R.H.	1

Fig. 4 – Heavy Duty Bumper Kit, 1480

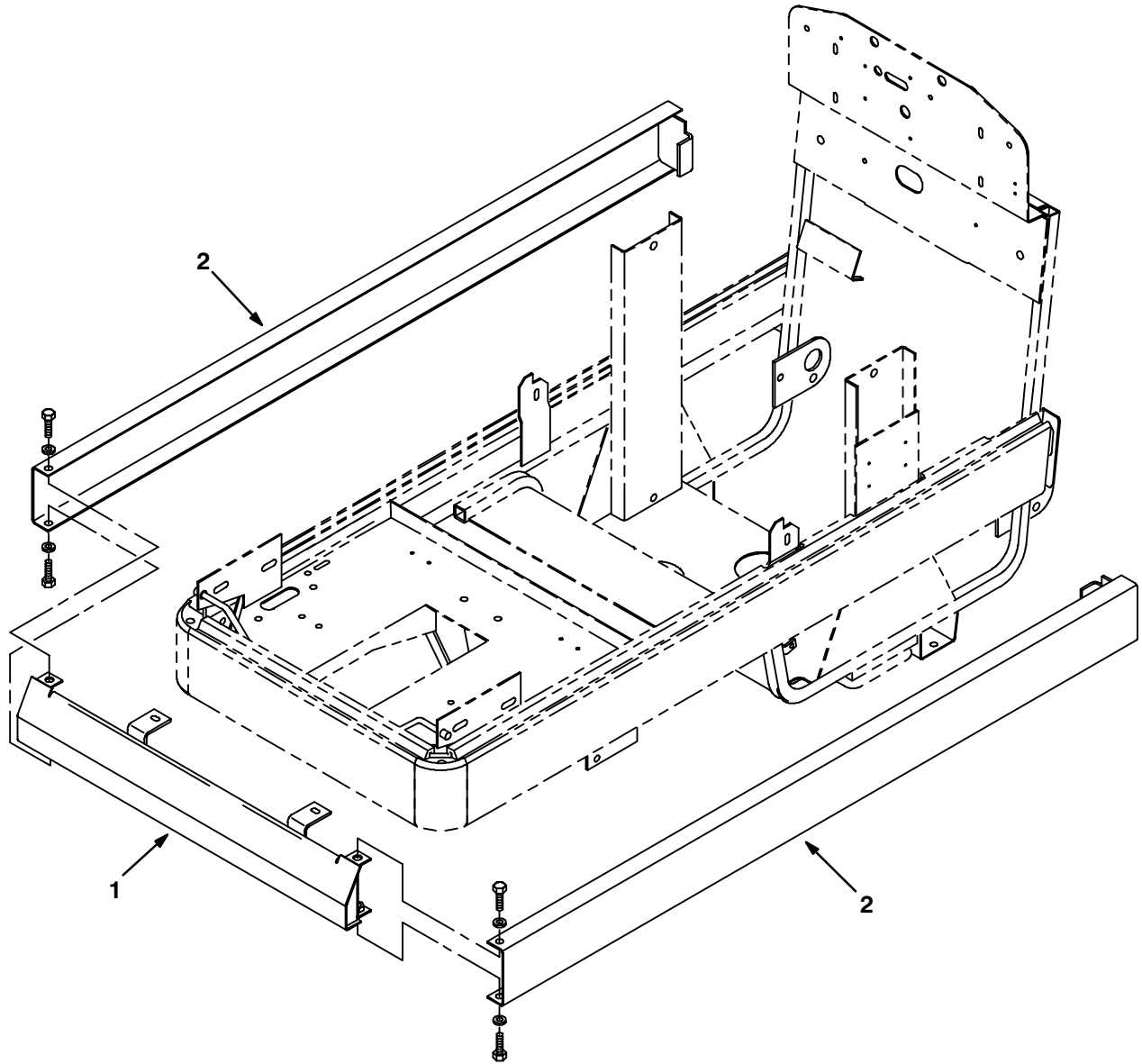

06151/06152

	Ref.	Tennant Part No.	Machine Serial Number	Description	Qty.
▽		24837	(040470–) Heavy Duty Bumper Kit	1
▲	1	24798	(040470–) Bumper, Front	1
▲	2	24942	(040470–) Bumper, Side Channel	2

Fig. 5 – Heavy Duty Bumper Kit, 1490

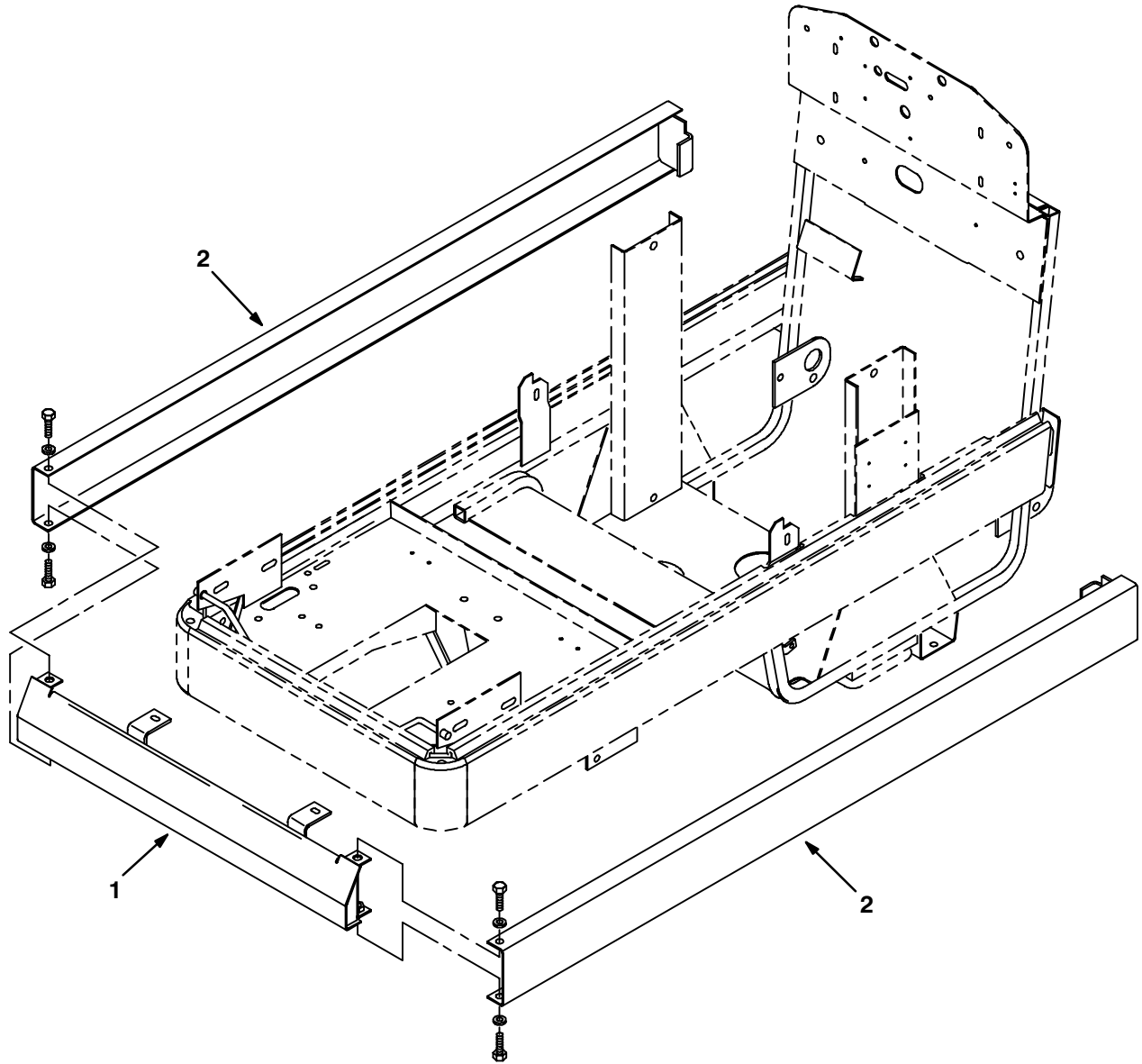

06303/06152

	Ref.	Tennant Part No.	Machine Serial Number	Description	Qty.
▽		24837	(070000–)	Heavy Duty Bumper Kit	1
▲	1	24798	(070000–)	Bumper, Front	1
▲	2	24942	(070000–)	Bumper, Side Channel	2

Fig. 6 – Demo Group, 1465

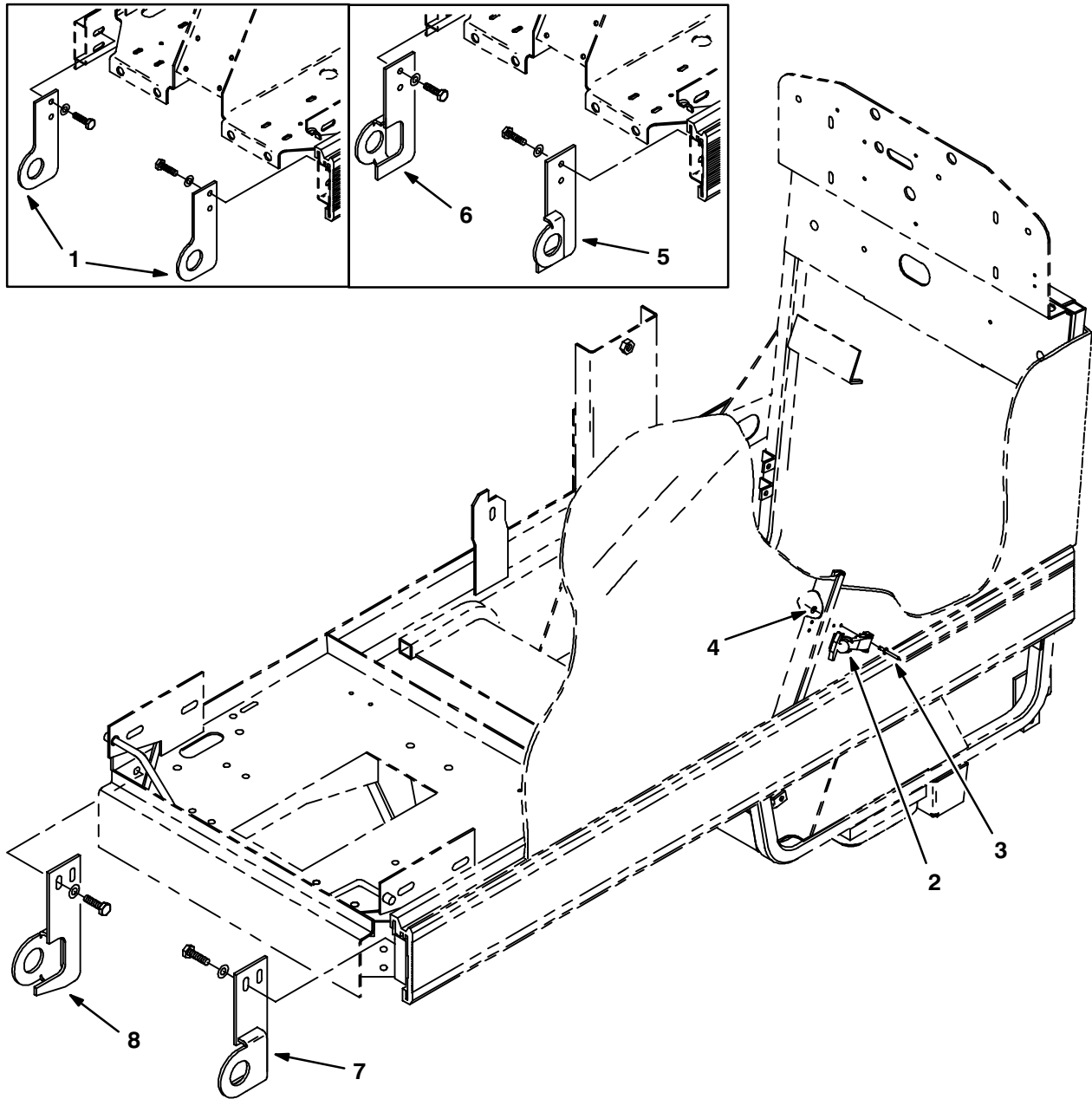

06156/05077

Ref.	Tennant Part No.	Machine Serial Number	Description	Qty.
1	33497	(030000–030130)	Bracket Kit, Tie Down	1
2	11636	(030000–)	Latch, Flexible Draw	2
3	08875	(030000–)	Rivet, Pop	8
4	02892	(030000–)	Washer	8
5	28356	(030131–030172)	Plate, Tie Down, L.H.	1
6	28357	(030131–030172)	Plate, Tie Down, R.H.	1
7	33530	(030173–)	Plate, Cover Mount, L.H.	1
8	33531	(030173–)	Plate, Cover Mount, R.H.	1

Fig. 7 – Demo Group, 1480

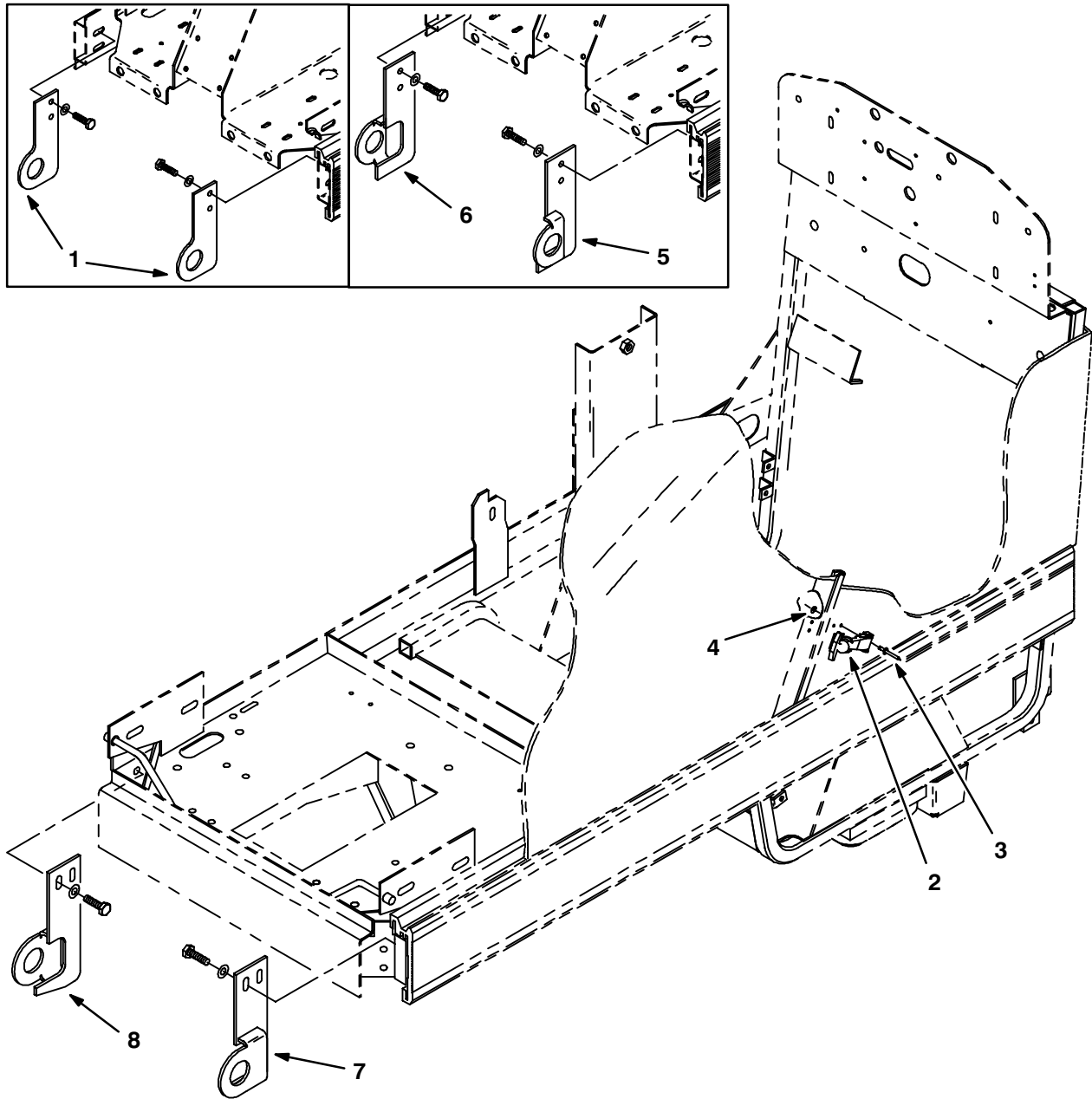

06157/05077

Ref.	Tennant Part No.	Machine Serial Number	Description	Qty.
1	33497	(040000–040291)	Bracket Kit, Tie Down	1
2	11636	(040000–)	Latch, Flexible Draw	2
3	08875	(040000–)	Rivet, Pop	8
4	02892	(040000–)	Washer	8
5	28356	(040292–040469)	Plate, Tie Down, L.H.	1
6	28357	(040292–040469)	Plate, Tie Down, R.H.	1
7	33530	(040470–)	Plate, Cover Mount, L.H.	1
8	33531	(040470–)	Plate, Cover Mount, R.H.	1

Fig. 8 – Demo Group, 1490

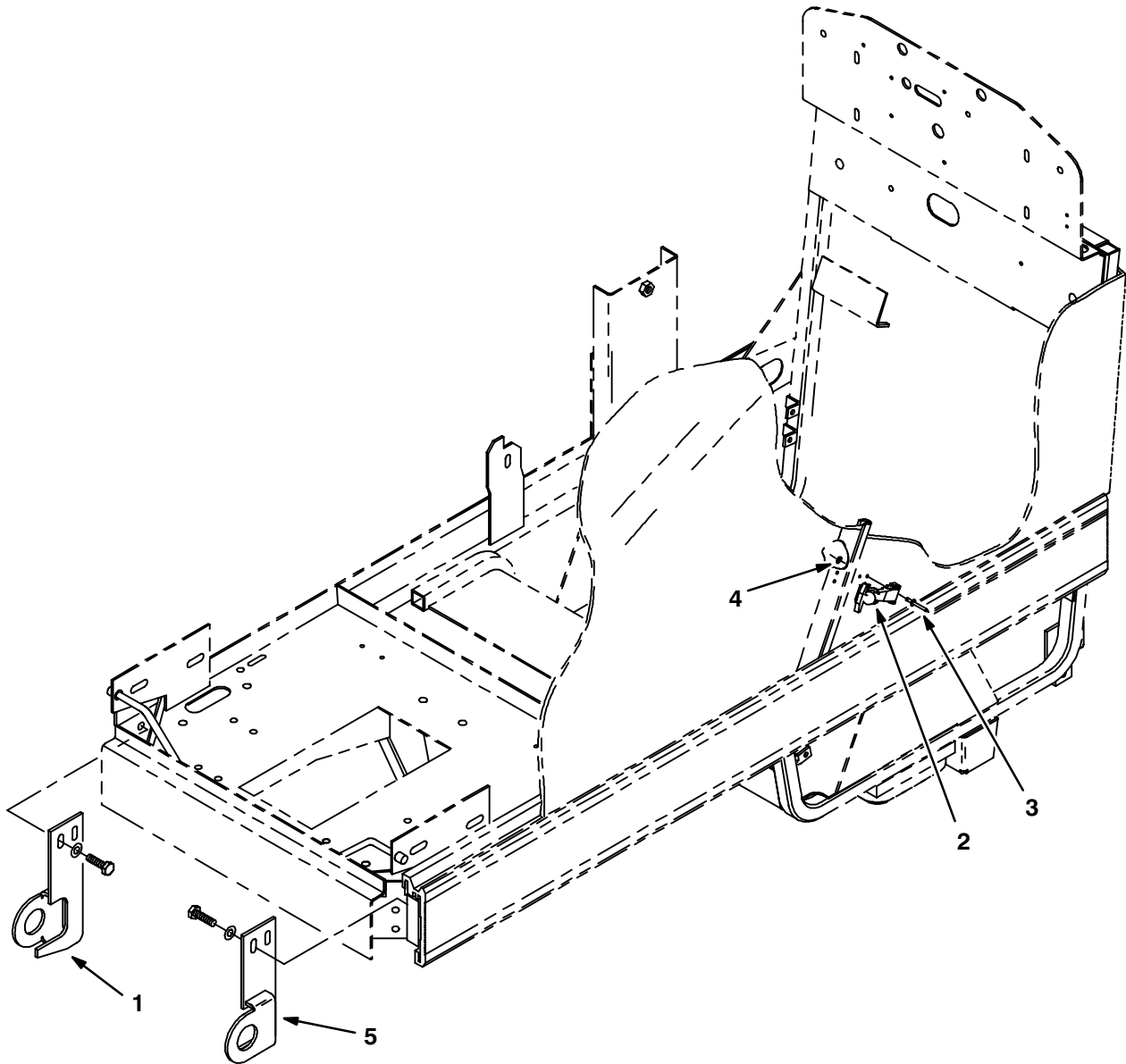

06305/05077

Ref.	Tennant Part No.	Machine Serial Number	Description	Qty.
1	28584	(070000–)	Plate, Cover Mount, R.H.	1
2	11636	(070000–)	Latch, Flexible Draw	2
3	82457	(070000–)	Rivet, Pop	8
4	02892	(070000–)	Washer	8
5	28583	(070000–)	Plate, Cover Mount, L.H.	1

Fig. 9 – Vacuum Wand Kit

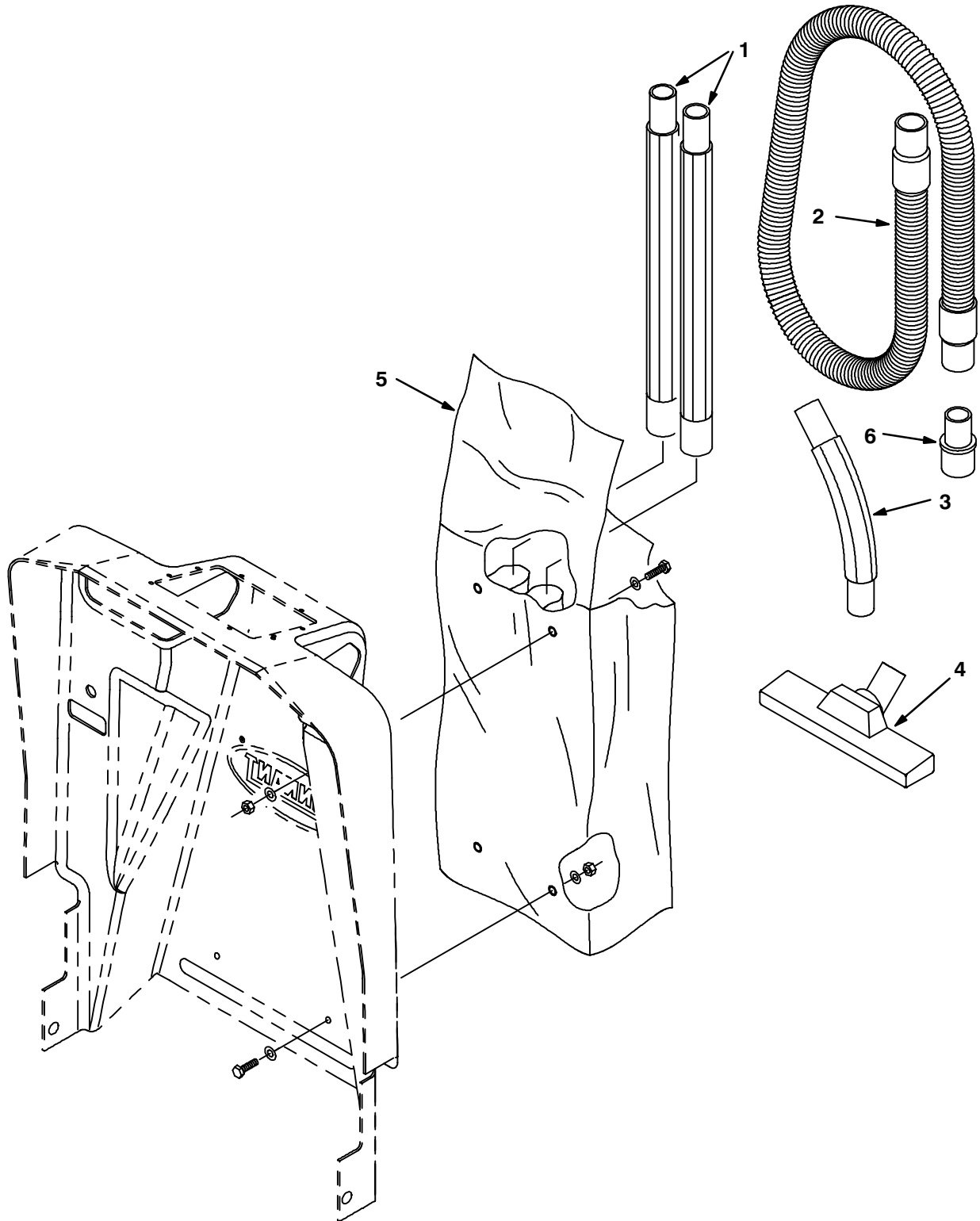
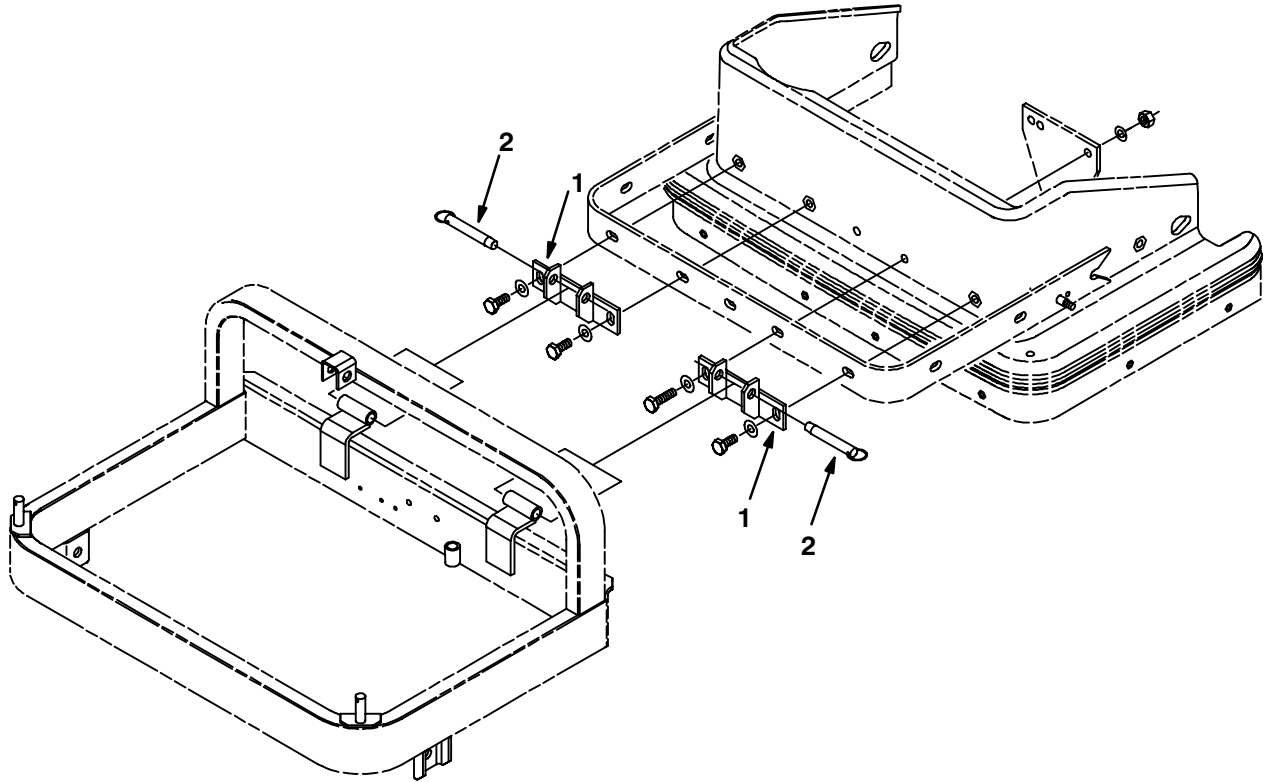

Fig. 9 – Vacuum Wand Kit

	Ref.	Tennant Part No.	Machine Serial Number	Description	Qty.
▽		11667	(000000–) Wand Kit, Vacuum	1
▲	1	05579	(000000–) Wand, Vacuum	2
▲	2	05594	(000000–) Hose Assembly, Vacuum Wand	1
▲	3	05584	(000000–) Hose End, Curved	1
▲	4	05578	(000000–) Nozzle, Vacuum Wand	1
▲	5	65580	(000000–) Bag, Power Wand	1
▲	6	04701	(000000–) Fitting, Reducer	1

Fig. 10 – Pre-Sweep™ Mounting Group, 1465



04213/04213

Ref.	Tennant Part No.	Machine Serial Number	Description	Qty.
1	11480	(000000–)	Bracket, Pivot Mounting	2
2	10985	(000000–)	Pin, Hitch	2

Fig. 11 – Pre-Sweep™ Mounting Group, 1480

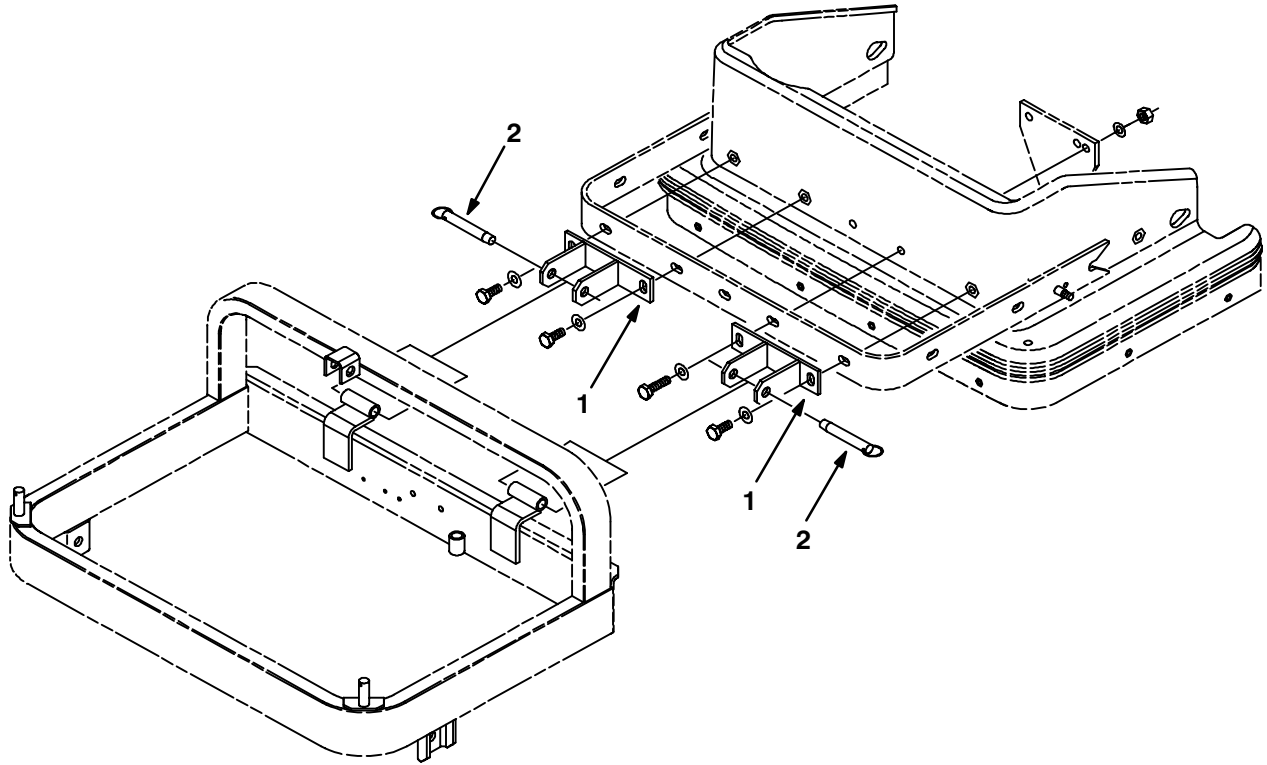

04214/4214

Ref.	Tennant Part No.	Machine Serial Number	Description	Qty.
1	05795	(000000–)	Bracket, Pivot Mounting	2
2	10985	(000000–)	Pin, Hitch	2

Fig. 12 – Pre-Sweep™ Drive Group, 1465

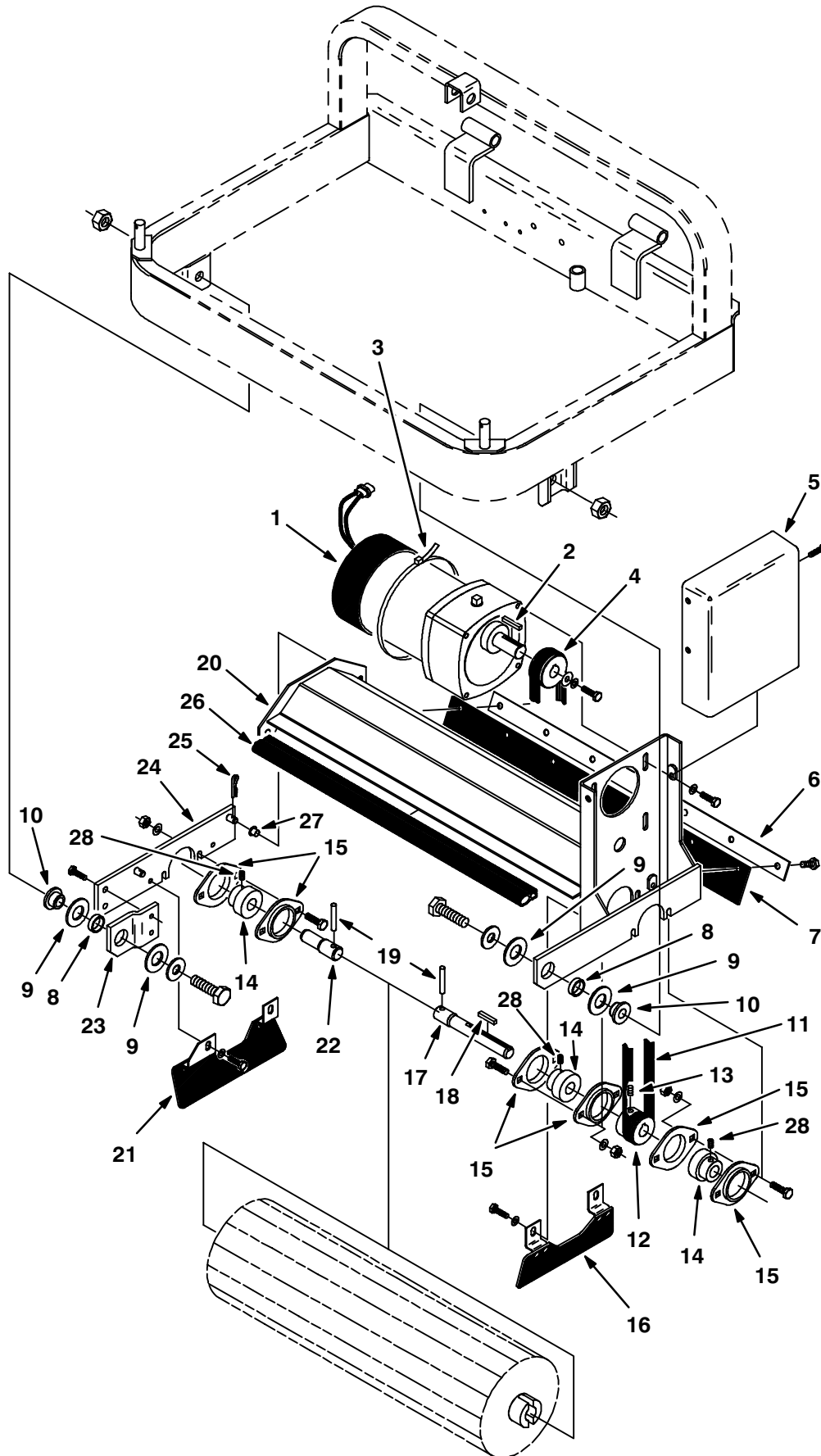

Fig. 12 – Pre-Sweep™ Drive Group, 1465

Ref.	Tennant Part No.	Machine Serial Number	Description	Qty.
1	04656	(000000–) Motor, Electric (See Breakdowns)	1
2	00911	(000000–) Key, Square	1
3	44961	(000000–) Tie, Cable	1
4	04620	(000000–) Sheave	1
5	04707	(000000–) Cover, Belt	1
6	11239	(000000–) Retainer, Recirculation Flap	1
7	11238	(000000–) Flap, Recirculation	1
8	04710	(000000–) Bearing	2
9	76979	(000000–) Bearing, Thrust	4
10	04632	(000000–) Bushing, Shoulder	2
11	04618	(000000–) Belt, Multi-V	1
12	04619	(000000–) Sheave	1
13	09162	(000000–) Screw, Nylon Lock Set, M6	1
14	48635	(000000–) Bearing and Collar	3
15	48636	(000000–) Flange, Bearing	6
16	11213	(000000–) Skirt Assembly, L.H.	1
17	04629	(000000–) Shaft, Drive	1
18	00913	(000000–) Key, Square	1
19	26315	(000000–) Pin, Roll	2
20	11236	(000000–) Housing, Brush	1
21	11214	(000000–) Skirt Assembly, R.H.	1
22	04630	(000000–) Shaft, Idler	1
23	04645	(000000–) Arm, Front Brush, R.H.	1
24	04642	(000000–) Arm, Brush, R.H.	1
25	86866	(000000–) Pin, Hair Cotter	1
26	11241	(000000–) Seal, Hopper	1
27	11747	(000000–) Bearing, Nylon	2
28	57497	(000000–) Screw, Set	3

Fig. 13 – Pre-Sweep™ Drive Group, 1480

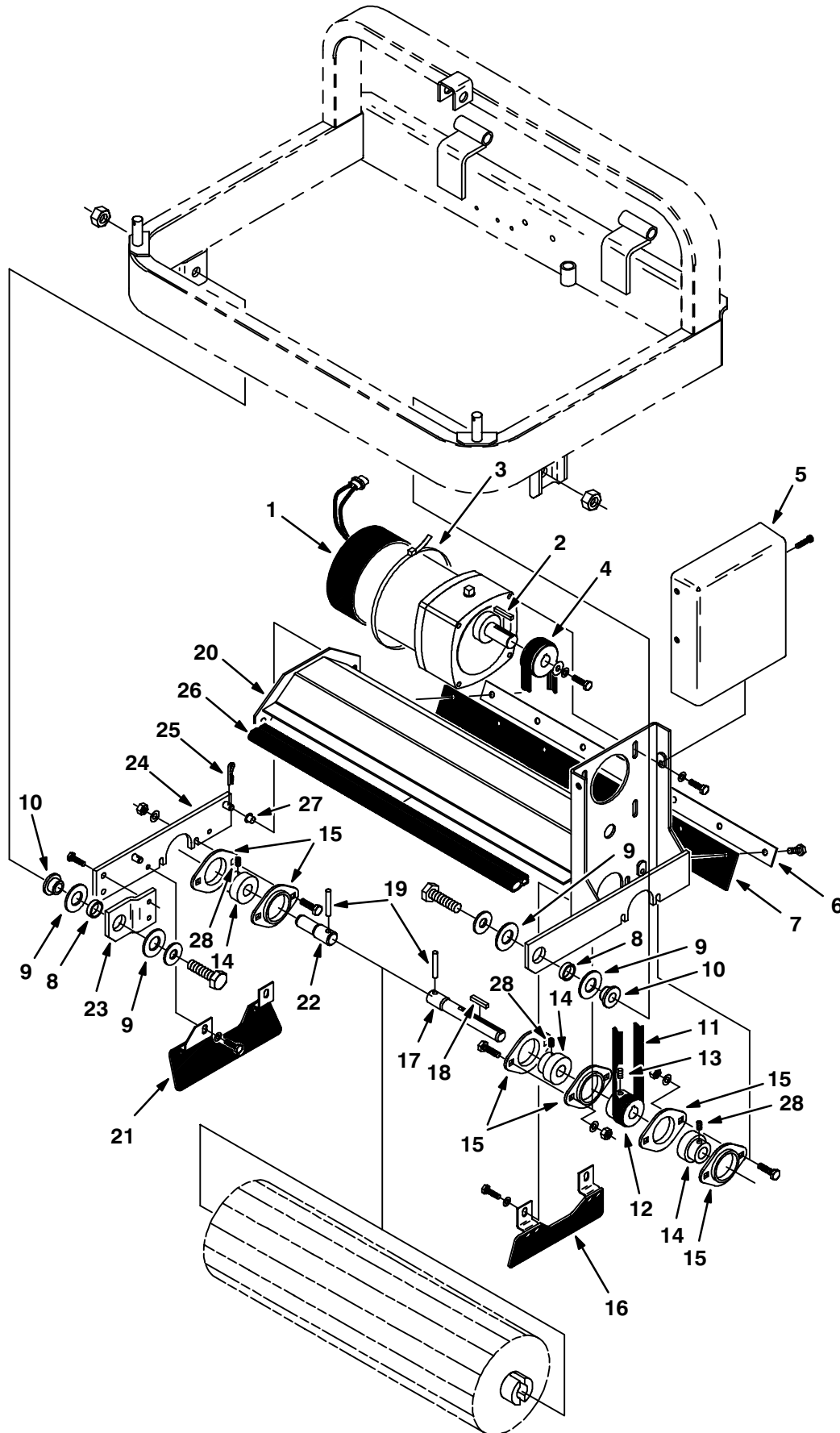

Fig. 13 – Pre-Sweep™ Drive Group, 1480

Ref.	Tennant Part No.	Machine Serial Number	Description	Qty.
1	04656	(000000–)	Motor, Electric (See Breakdowns)	1
2	00911	(000000–)	Key, Square	1
3	44961	(000000–)	Tie, Cable	1
4	04620	(000000–)	Sheave	1
5	04707	(000000–)	Cover, Belt	1
6	04745	(000000–)	Retainer, Recirculation Flap	1
7	04713	(000000–)	Flap, Recirculation	1
8	04710	(000000–)	Bearing	2
9	76979	(000000–)	Bearing, Thrust	4
10	04632	(000000–)	Bushing, Shoulder	2
11	04618	(000000–)	Belt, Multi-V	1
12	04619	(000000–)	Sheave	1
13	09162	(000000–)	Screw, Nylon Lock Set, M6	1
14	48635	(000000–)	Bearing and Collar	3
15	48636	(000000–)	Flange, Bearing	6
16	11213	(000000–)	Skirt Assembly, L.H.	1
17	04629	(000000–)	Shaft, Drive	1
18	00913	(000000–)	Key, Square	1
19	26315	(000000–)	Pin, Roll	2
20	04636	(000000–)	Housing, Brush	1
21	11214	(000000–)	Skirt Assembly, R.H.	1
22	04630	(000000–)	Shaft, Idler	1
23	04645	(000000–)	Arm, Front Brush, R.H.	1
24	04642	(000000–)	Arm, Brush, R.H.	1
25	86866	(000000–)	Pin, Hair Cotter	1
26	04664	(000000–)	Seal, Hopper	1
27	11747	(000000–)	Bearing, Nylon	2
28	57497	(000000–)	Screw, Set	3

Fig. 14 – Pre-Sweep™ Frame Group, 1465

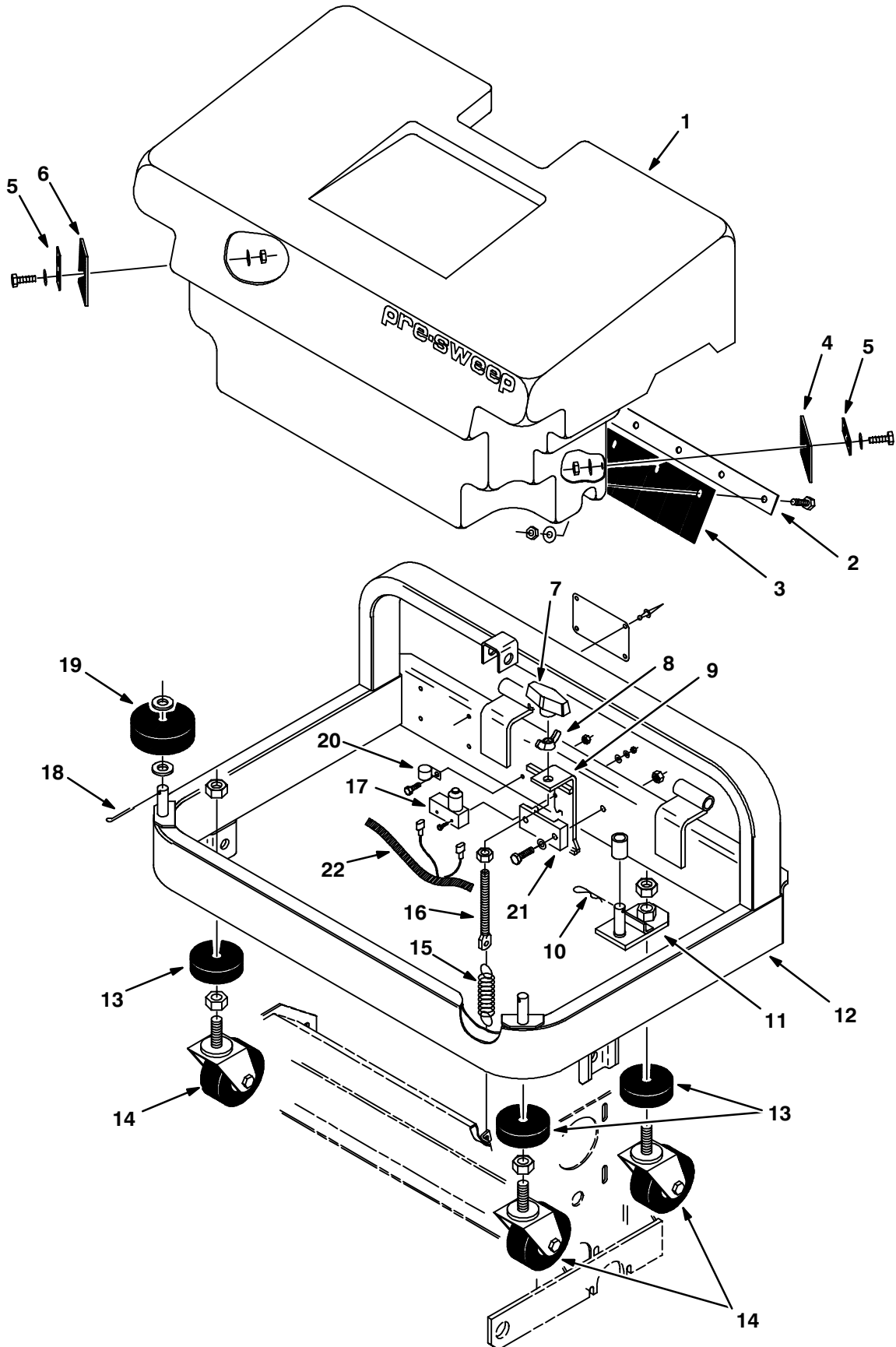

Fig. 14 – Pre-Sweep™ Frame Group, 1465

Ref.	Tennant Part No.	Machine Serial Number	Description	Qty.
1	11149	(000000–) Hopper, Pre-Sweep™	1
2	11243	(000000–) Strip, Retainer	1
3	11242	(000000–) Skirt, Hopper Slit	1
4	06211	(000000–) Skirt, Hopper, L.H.	1
5	06213	(000000–) Retainer, Hopper Skirt	2
6	05621	(000000–) Skirt, Hopper, R.H.	1
7	04706	(000000–) Handle, Brush Lift	1
8	39273	(000000–) Nut, Wing	1
9	10970	(000000–) Bracket, Brush Lift	1
10	02942	(000000–) Pin, Hair Cotter	1
11	11580	(000000–) Plate, Caster	1
12	11235	(000000–) Frame, Pre-Sweep™	1
13	75968	(000000–) Seal, Bearing	3
14	75977	(000000–) Caster, Swivel	3
15	04665	(000000–) Spring, Tension	1
16	04637	(000000–) Screw, Adjust	1
17	10982	(000000–) Switch, Micro, SPDT	1
18	08182	(000000–) Pin, Cotter	2
19	86800	(000000–) Wheel	2
20	26395–2	(000000–) Clamp, Cable	1
21	10976	(000000–) Block, Brush Lift Mounting	1
22	10983	(000000–) Harness, Pre-Sweep™	1

Fig. 15 – Pre-Sweep™ Frame Group, 1480

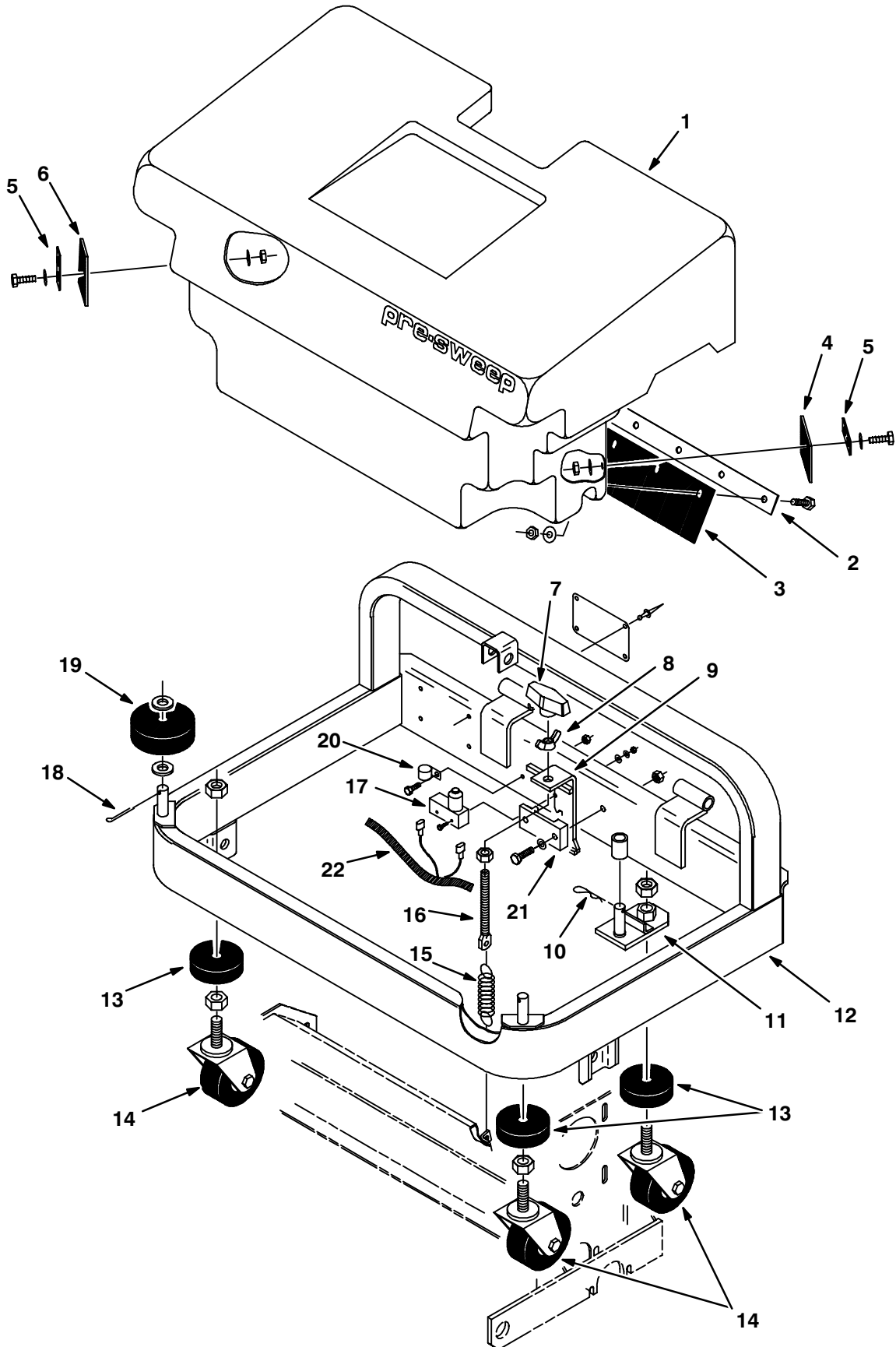

Fig. 15 – Pre-Sweep™ Frame Group, 1480

Ref.	Tennant Part No.	Machine Serial Number	Description	Qty.
1	04625	(000000–) Hopper, Pre-Sweep™	1
2	04641	(000000–) Strip, Retainer	1
3	04640	(000000–) Skirt, Hopper Slit	1
4	06211	(000000–) Skirt, Hopper, L.H.	1
5	06213	(000000–) Retainer, Hopper Skirt	2
6	05621	(000000–) Skirt, Hopper, R.H.	1
7	04706	(000000–) Handle, Brush Lift	1
8	39273	(000000–) Nut, Wing	1
9	10970	(000000–) Bracket, Brush Lift	1
10	02942	(000000–) Pin, Hair Cotter	1
11	11580	(000000–) Plate, Caster	1
12	04644	(000000–) Frame, Pre-Sweep™	1
13	75968	(000000–) Seal, Bearing	3
14	75977	(000000–) Caster, Swivel	3
15	04665	(000000–) Spring, Tension	1
16	04637	(000000–) Screw, Adjust	1
17	10982	(000000–) Switch, Micro, SPDT	1
18	08182	(000000–) Pin, Cotter	2
19	86800	(000000–) Wheel	2
20	26395–2	(000000–) Clamp, Cable	1
21	10976	(000000–) Block, Brush Lift Mounting	1
22	10983	(000000–) Harness, Pre-Sweep™	1

Fig. 16 – Extended Scrub Group, 1465

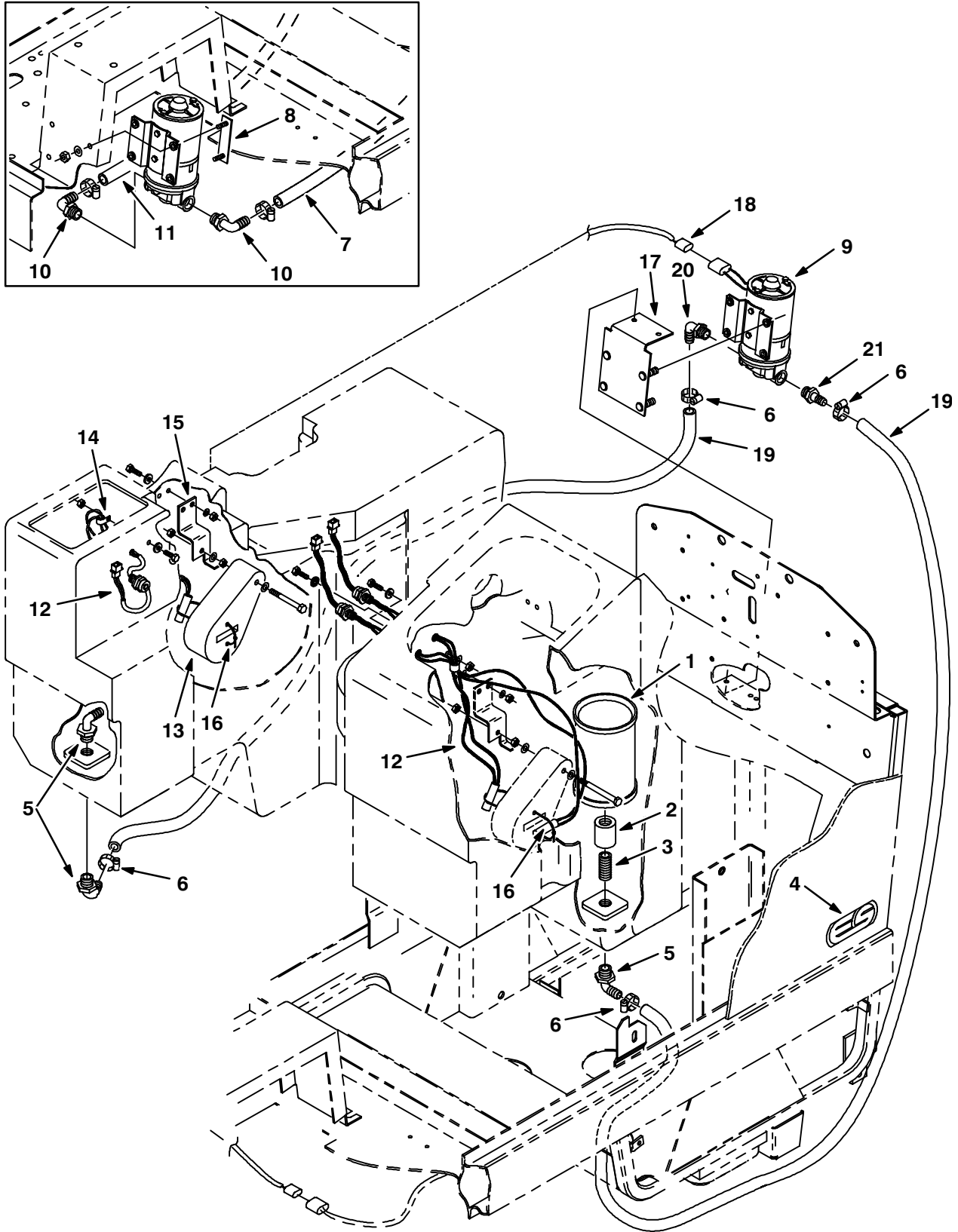

Fig. 16 – Extended Scrub Group, 1465

Ref.	Tenant Part No.	Machine Serial Number	Description	Qty.
1	41304	(030000–) Screen, Double Cylinder Solution	1
2	05134	(030000–) Fitting, Pipe	1
3	69784	(030000–) Fitting, Nipple	1
4	11578	(030000–) Label, ES™ Logo	2
5	63244–3	(030000–) Fitting, Barbed Elbow	3
6	54333	(030000–) Clamp, Worm Drive	4
7	05713	(030000–030361) Hose, PVC	1
8	04740	(030000–030361) Plate, Pump Mounting	2
9	10916	(030000–) Pump, Water (See Breakdowns)	1
10	64778	(030000–030361) Fitting, Barbed Elbow	2
11	05716	(030000–030361) Hose, Vinyl	1
12	10935	(030000–030118) Mercury Switch Assembly	2
12	28346	(030119–) Mercury Switch Assembly	2
13	65683	(030000–) Float, Water Level	1
14	33584	(030000–) Clamp, Cable	1
15	05567	(030000–) Bracket, Water Level Control	1
16	49266	(030000–) Tie, Cable	4
17	65698	(030362–) Bracket, Water Pump	1
18	65717	(030362–) Wire Harness, 1465	1
19	65713	(030362–) Hose, PVC	2
20	64778	(030362–) Fitting, Barbed Elbow	1
21	64743	(030362–) Fitting, Barbed Straight	1

Fig. 17 – Extended Scrub Group, 1480

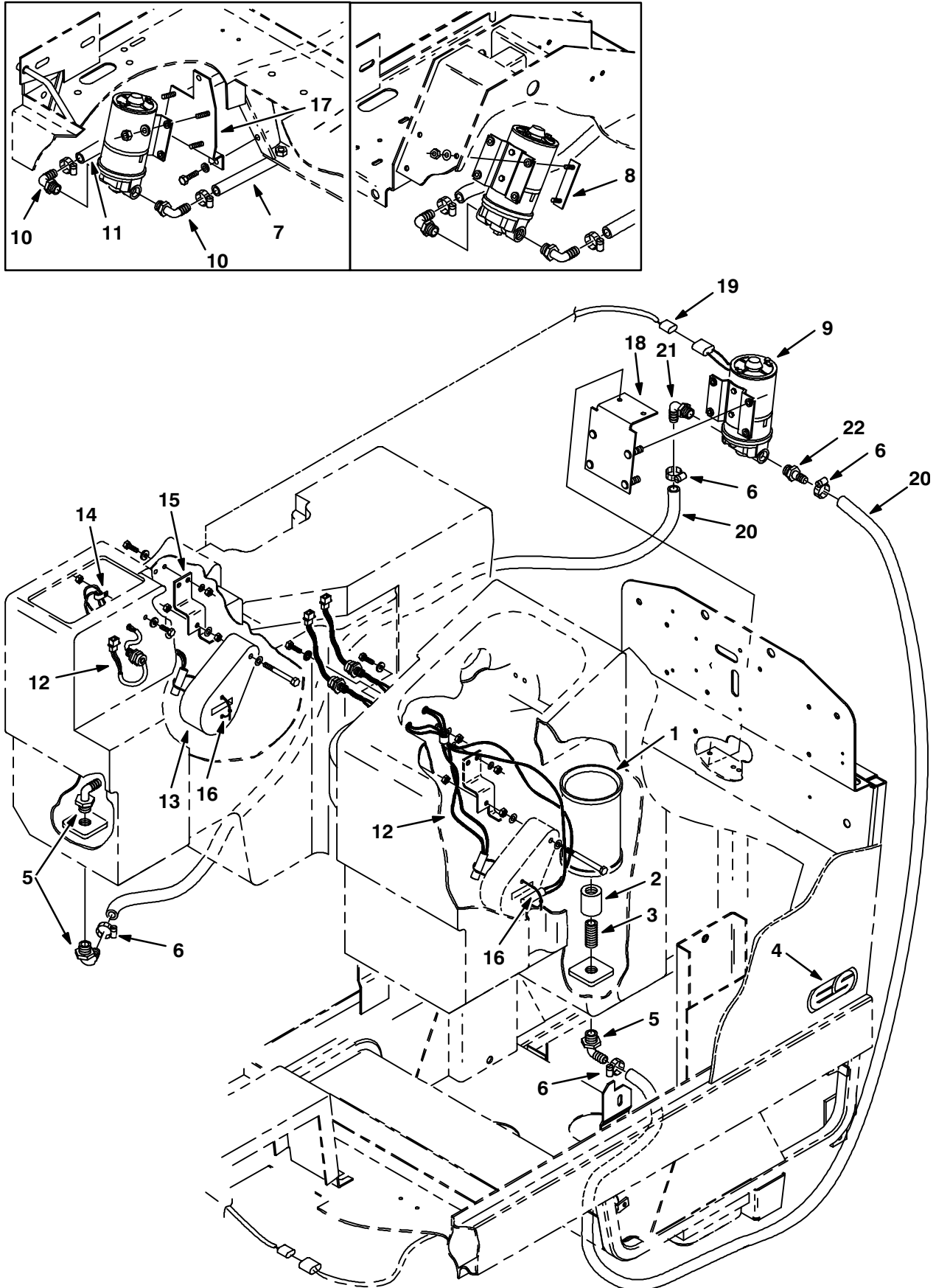

Fig. 17 – Extended Scrub Group, 1480

Ref.	Tenant Part No.	Machine Serial Number	Description	Qty.
1	41304	(040000–) Screen, Double Cylinder Solution	1
2	05134	(040000–) Fitting, Pipe	1
3	69784	(040000–) Fitting, Nipple	1
4	11578	(040000–) Label, ES™ Logo	2
5	63244–3	(040000–) Fitting, Barbed Elbow	3
6	54333	(040000–) Clamp, Worm Drive	4
7	05713	(040000–040819) Hose, PVC	1
8	04740	(040000–040469) Plate, Pump Mounting	2
9	10916	(040000–) Pump, Water (See Breakdowns)	1
10	64778	(040000–040819) Fitting, Barbed Elbow	2
11	05716	(040000–040819) Hose, Vinyl	1
12	10935	(040000–040271) Mercury Switch Assembly	2
12	28346	(040272–) Mercury Switch Assembly	2
13	65683	(040000–) Float, Water Level	1
14	33584	(040000–) Clamp, Cable	1
15	05567	(040000–) Bracket, Water Level Control	1
16	49266	(040000–) Tie, Cable	2
17	27953	(040470–040819) Bracket, Mount	1
18	65698	(040820–) Bracket, Water Pump	1
19	65717	(040820–) Wire Harness, 1480	1
20	65713	(040820–) Hose, PVC	2
21	64778	(040820–) Fitting, Barbed Elbow	1
22	64743	(040820–) Fitting, Barbed Straight	1

Fig. 18 – Extended Scrub Group, 1490

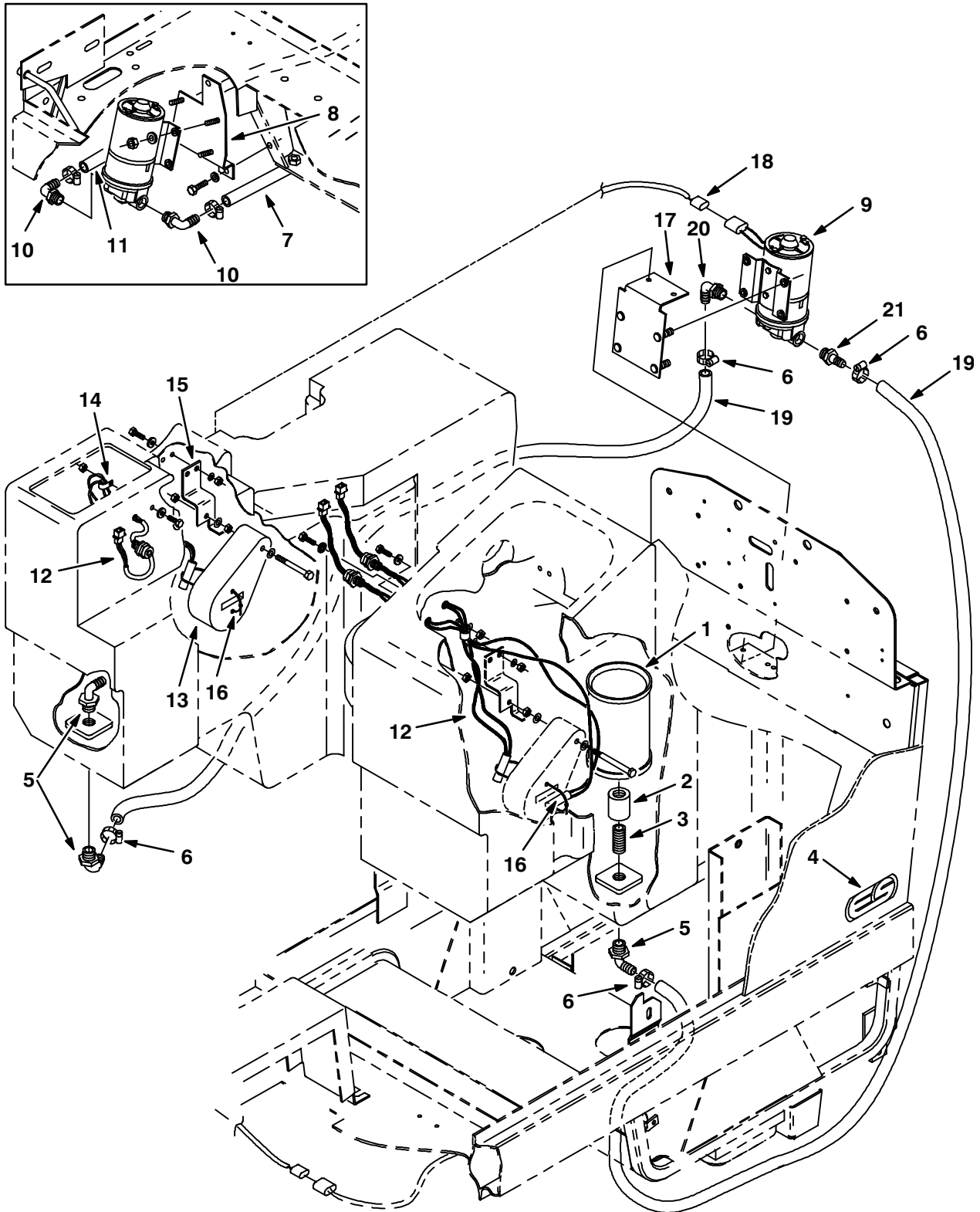
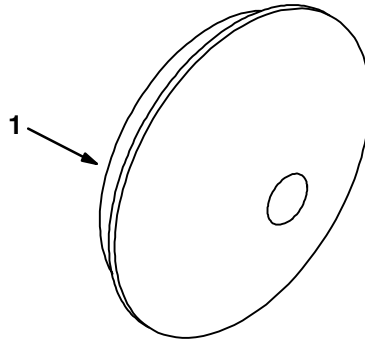

Fig. 18 – Extended Scrub Group, 1490

Ref.	Tenant Part No.	Machine Serial Number	Description	Qty.
1	41304	(070000–) Screen, Double Cylinder Solution	1
2	05134	(070000–) Fitting, Pipe	1
3	69784	(070000–) Fitting, Nipple	1
4	11578	(070000–) Label, ES™ Logo	2
5	63244–3	(070000–) Fitting, Barbed Elbow	3
6	54333	(070000–) Clamp, Worm Drive	4
7	05713	(070000–070077) Hose, PVC	1
8	27953	(070000–070077) Bracket, Mount	1
9	10916	(070000–) Pump, Water (See Breakdowns)	1
10	64778	(070000–070077) Fitting, Barbed Elbow	2
11	05716	(070000–070077) Hose, Vinyl	1
12	28346	(070000–) Mercury Switch Assembly	2
13	65683	(070000–) Float, Water Level	1
14	33584	(070000–) Clamp, Cable	1
15	05567	(070000–) Bracket, Water Level Control	1
16	49266	(070000–) Tie, Cable	2
17	65698	(070078–) Bracket, Water Pump	1
18	65717	(070078–) Wire Harness, 1490	1
19	65713	(070078–) Hose, PVC	2
20	64778	(070078–) Fitting, Barbed Elbow	1
21	64743	(070078–) Fitting, Barbed Straight	1

Fig. 19 – Wheel Cover Group



05380/05380

Ref.	Tennant Part No.	Machine Serial Number	Description	Qty.
1	11581	(000000–)	Cover, Wheel	2

Fig. 20 – Foam Filled Tire Group

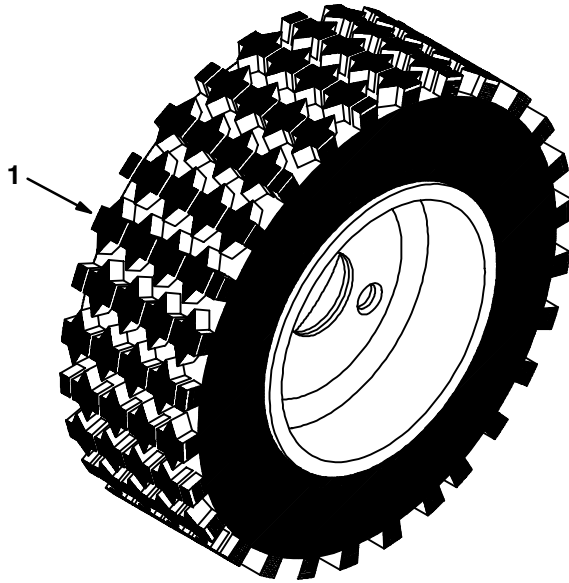

04765/04765

Ref.	Tennant Part No.	Machine Serial Number	Description	Qty.
1	61598	(000000–) Tire and Rim Assembly, Foam Filled	2

Fig. 21 – Dual Parking Brake Group

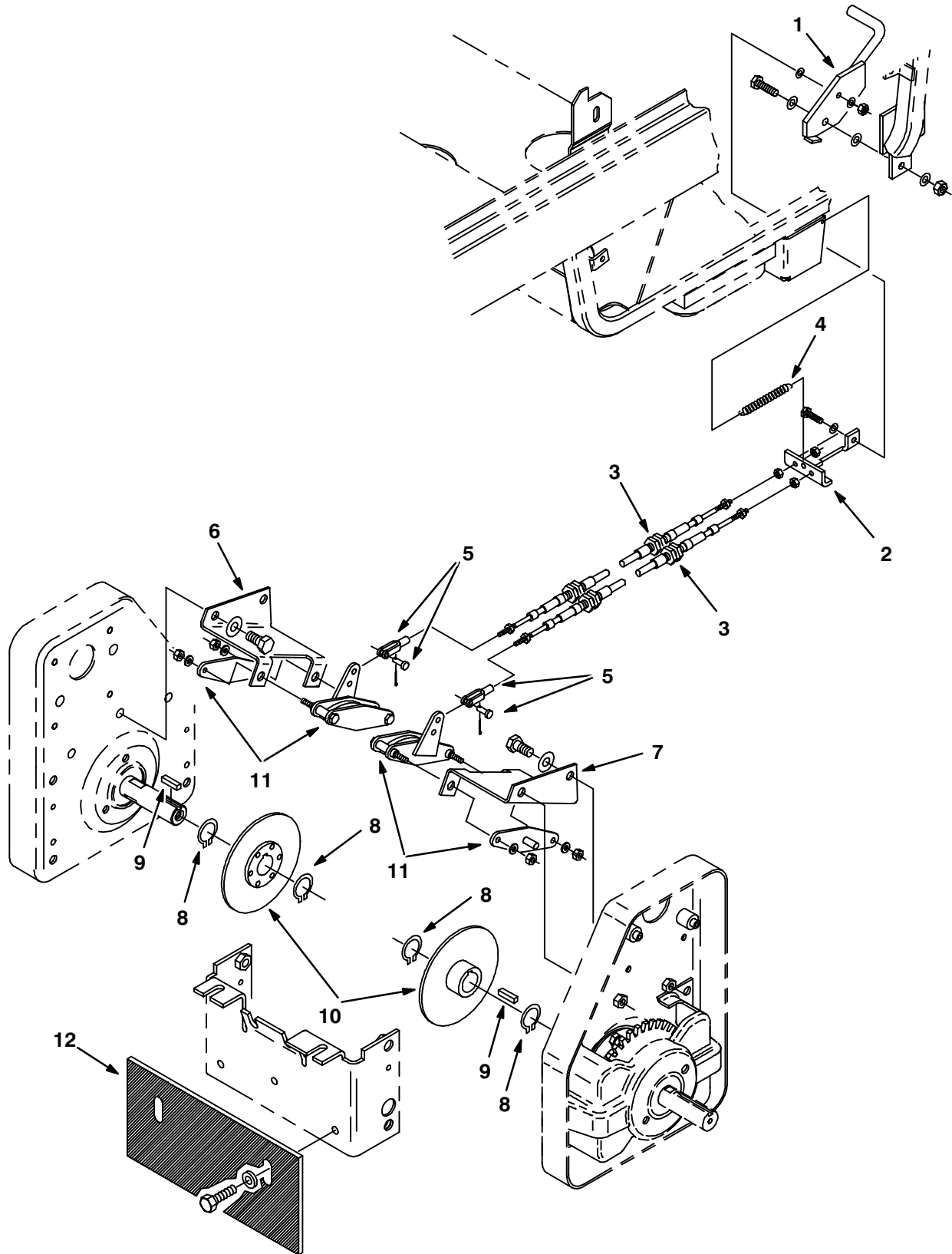

Fig. 21 – Dual Parking Brake Group

Ref.	Tennant Part No.	Machine Serial Number	Description	Qty.
1	05409	(000000–)	Pedal, Brake	1
2	05396	(000000–)	Bracket, Brake	1
3	05390	(000000–)	Cable, Push/Pull	2
4	05552	(000000–)	Spring, Tension	1
5	27880	(000000–)	Yoke Assembly	2
6	05506	(000000–)	Bracket, Caliper Mounting, R.H.	1
7	05470	(000000–)	Bracket, Caliper Mounting, L.H.	1
8	09005	(000000–)	Ring, Retaining	4
9	00928	(000000–)	Key, Square	2
10	05297	(000000–)	Hub and Disc Assembly	2
11	35921	(000000–)	Disc Brake Assembly	2
12	24645	(000000–)	Skirt	1

Fig. 22 – GS Group, 1465

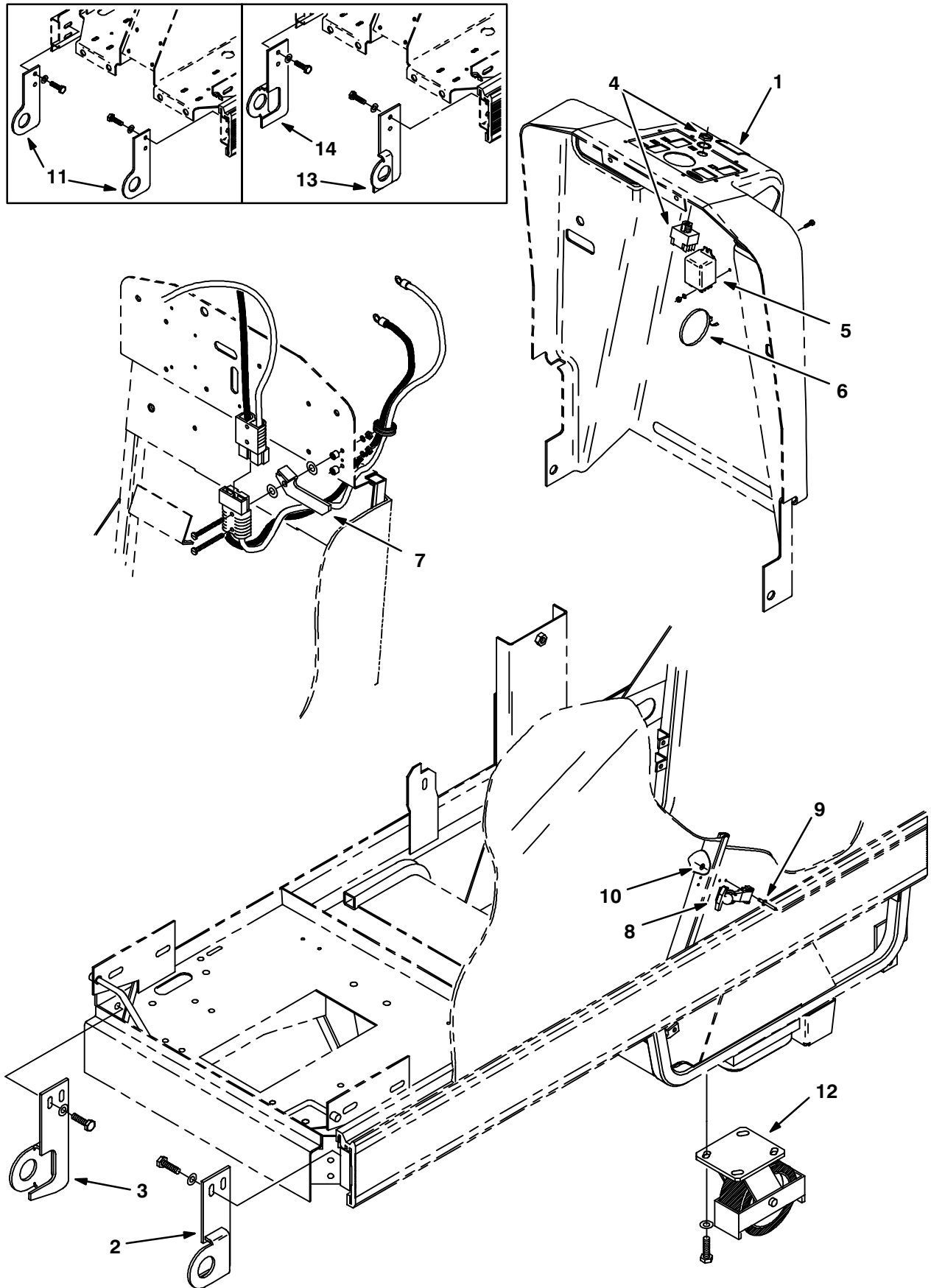

Fig. 22 – GS Group, 1465

Ref.	Tenant Part No.	Machine Serial Number	Description	Qty.
1	33444	(030000–)	Label, For Safety, GS	1
2	33530	(030173–)	Plate, Cover Mount, L.H.	1
3	33531	(030173–)	Plate, Cover Mount, R.H.	1
▽ 4	11651	(030000–)	Switch Assembly, Key	1
▲	31204	(030000–)	Key, Switch	1
5	87284	(030000–)	Relay, DPDT	1
6	49266	(030000–)	Tie, Cable	2
7	11610	(030000–)	Bracket, Hood	1
8	11636	(030000–)	Latch, Flexible Draw	2
9	08875	(030000–)	Rivet, Pop	8
10	02892	(030000–)	Washer	8
11	33497	(030000–030130)	Bracket Kit, Tie Down	1
12	24853	(030000–)	Caster, Protection, GS	2
13	28356	(030131–030172)	Plate, Tie Down, L.H.	1
14	28357	(030131–030172)	Plate, Tie Down, R.H.	1

Fig. 23 – GS Group, 1480

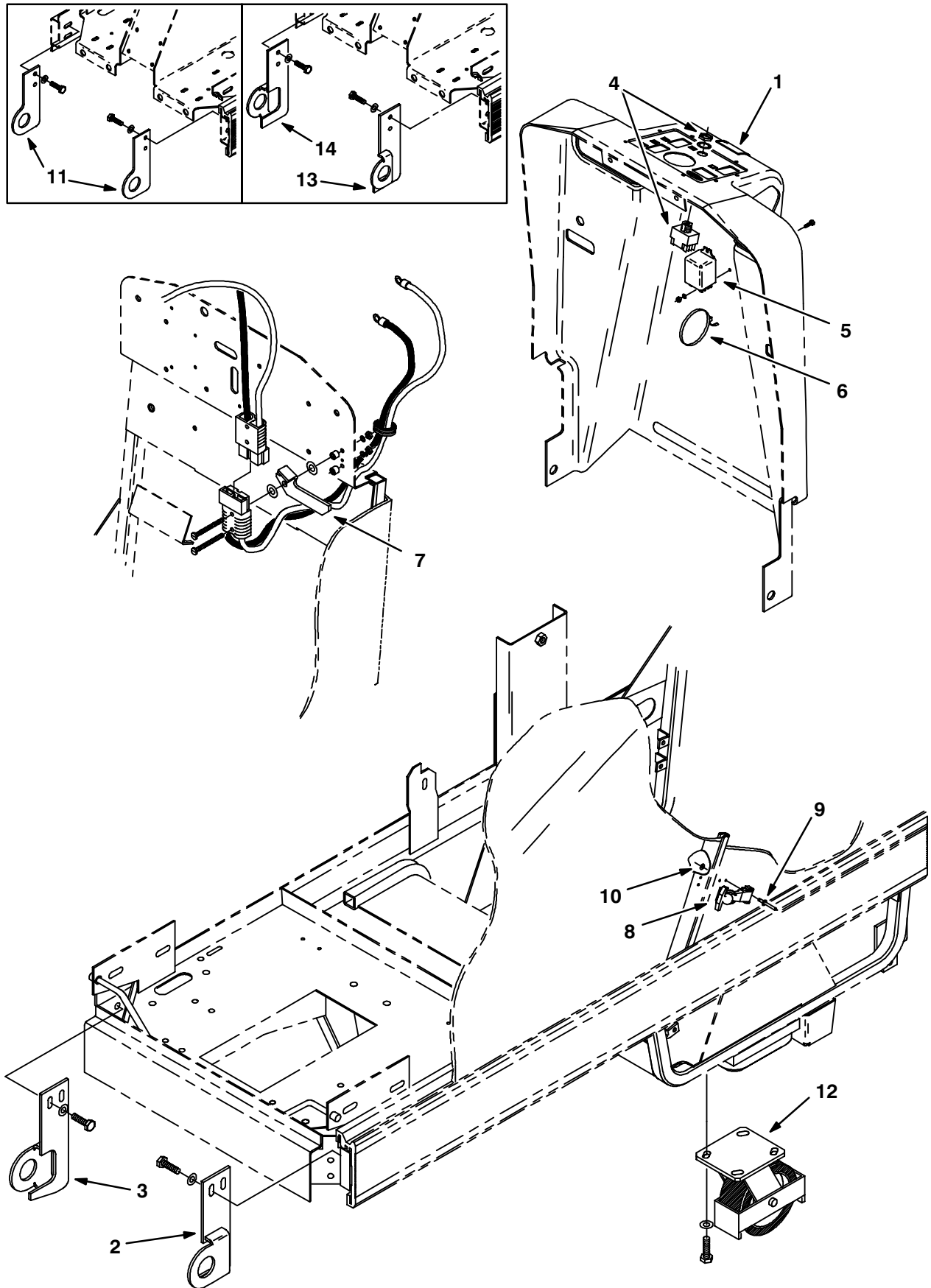
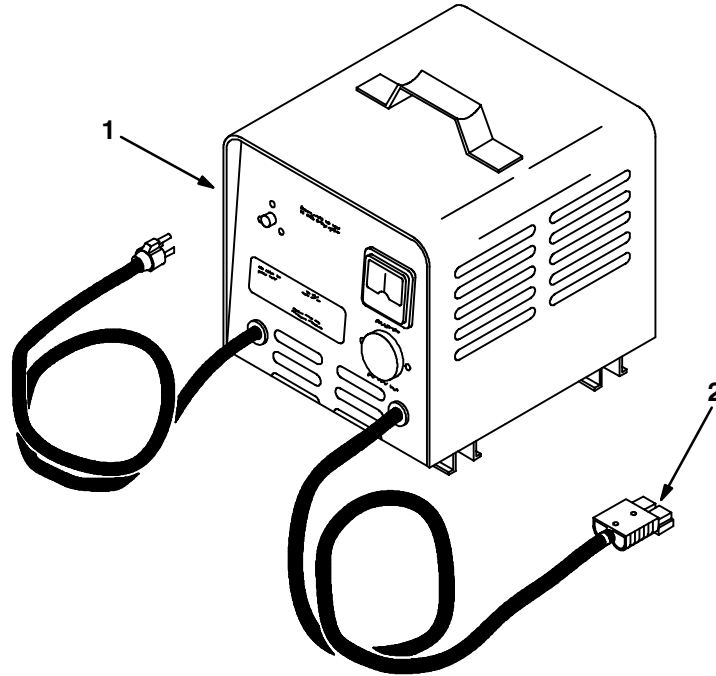

Fig. 23 – GS Group, 1480

Ref.	Tenant Part No.	Machine Serial Number	Description	Qty.
1	33444	(040000–)	Label, For Safety, GS	1
2	33530	(040470–)	Plate, Cover Mount, L.H.	1
3	33531	(040470–)	Plate, Cover Mount, R.H.	1
▽ 4	11651	(040000–)	Switch Assembly, Key	1
▲	31204	(040000–)	Key, Switch	1
5	87284	(040000–)	Relay, DPDT	1
6	49266	(040000–)	Tie, Cable	2
7	11610	(040000–)	Bracket, Hood	1
8	11636	(040000–)	Latch, Flexible Draw	2
9	08875	(040000–)	Rivet, Pop	8
10	02892	(040000–)	Washer	8
11	33497	(040000–040291)	Bracket Kit, Tie Down	1
12	24853	(040000–)	Caster, Protection, GS	2
13	28356	(040292–040469)	Plate, Tie Down, L.H.	1
14	28357	(040292–040469)	Plate, Tie Down, R.H.	1

Fig. 24 – Battery Charger Group, 60 Hz (220 Ah batteries)



04766/04766

	Ref.	Tennant Part No.	Machine Serial Number	Description	Qty.
∇	1	05263	(000000-xxxxxx)	Charger, Battery, 36V, 25A, 115V (Replaced By 65570)	1
▲	2	24881	(000000-xxxxxx)	Connector, Grey, SB50	1
▲		05264	(000000-xxxxxx)	Ammeter	1
▲		05265	(000000-xxxxxx)	Capacitor	1
▲		05266	(000000-xxxxxx)	Fuse Assembly	1
▲		28009	(000000-xxxxxx)	Diode Assembly	1

Fig. 25 – Battery Charger Group, 50 Hz (220 Ah batteries)

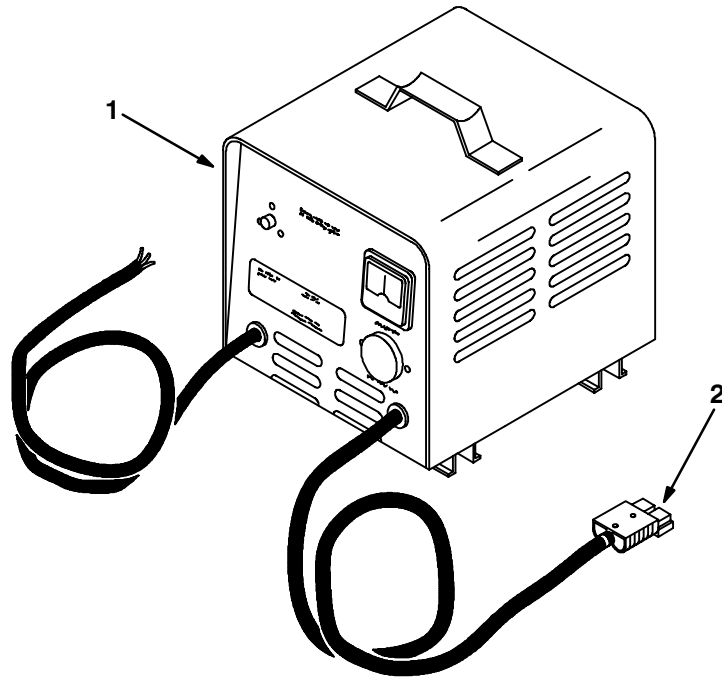

04767/04767

Ref.	Tennant Part No.	Machine Serial Number	Description	Qty.
∇ 1	05247	(000000-xxxxxx)	Charger, Battery, 36V, 25A, 230V (Replaced By 65572)	1
▲ 2	24881	(000000-xxxxxx)	Connector, Grey, SB50	1
▲	05264	(000000-xxxxxx)	Ammeter	1
▲	05265	(000000-xxxxxx)	Capacitor	1
▲	05266	(000000-xxxxxx)	Fuse Assembly	1
▲	28009	(000000-xxxxxx)	Diode Assembly	1

Fig. 26 – Battery Charger Group, 40A, 36V, 50 Hz (305 Ah batteries)

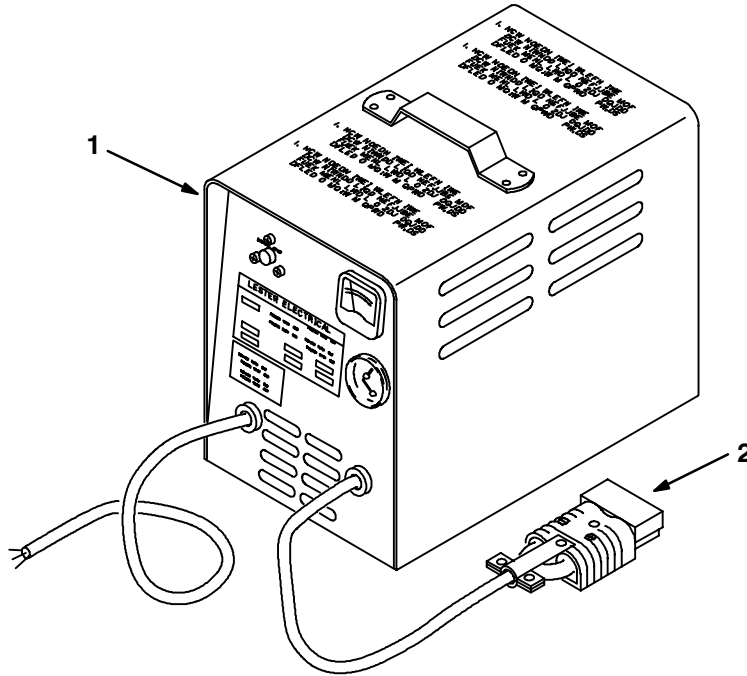

03569/03569

	Ref.	Tennant Part No.	Machine Serial Number	Description	Qty.
▽	1	87834	(000000-xxxxxx)	Charger, Battery, 40A, 36V, 50 Hz (Replaced By 65573)	1
▲	2	22892	(000000-xxxxxx)	Connector, Grey, SB175	1
▲		87994	(000000-xxxxxx)	Ammeter	1
▲		87995	(000000-xxxxxx)	Capacitor	1
▲		87996	(000000-xxxxxx)	Fuse Assembly	1
▲		87997	(000000-xxxxxx)	Heatsink Assembly	1
▲		87999	(000000-xxxxxx)	Timer Kit, Electric	1

Fig. 27 – Battery Charger Group, 36A, 36V, 115V (305 Ah batteries)

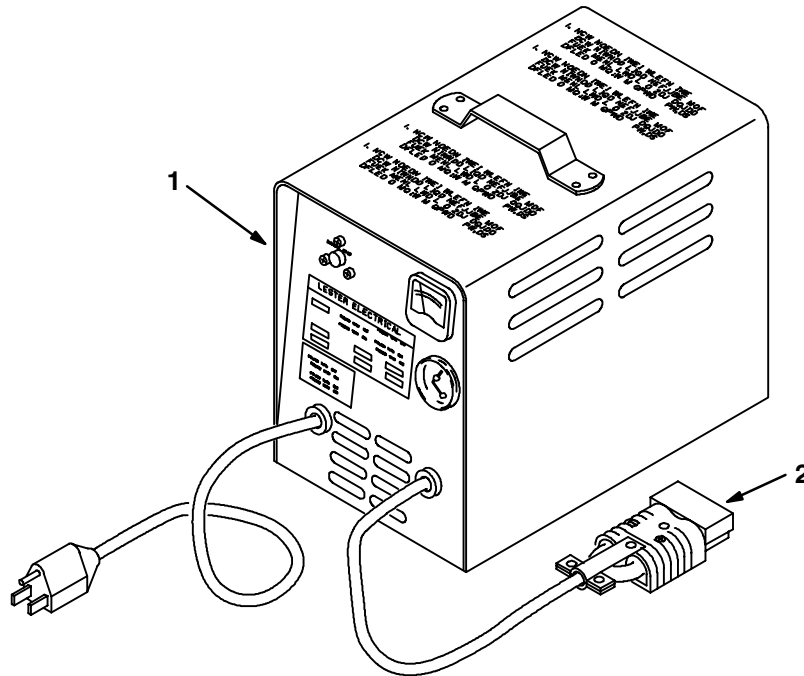

03360/03360

Ref.	Tennant Part No.	Machine Serial Number	Description	Qty.
▽ 1	87028	(000000–)	Charger, Battery, 36A, 36V, 115V	1
▲ 2	22892	(000000–)	Connector, Grey, SB175	1
▲	87994	(000000–)	Ammeter	1
▲	87995	(000000–)	Capacitor	1
▲	87996	(000000–)	Fuse Assembly	1
▲	87997	(000000–)	Heatsink Assembly	1
▲	87998	(000000–)	Timer Kit, Electric	1

Fig. 28 – Battery Charger Group, 60 Hz (220 Ah batteries)

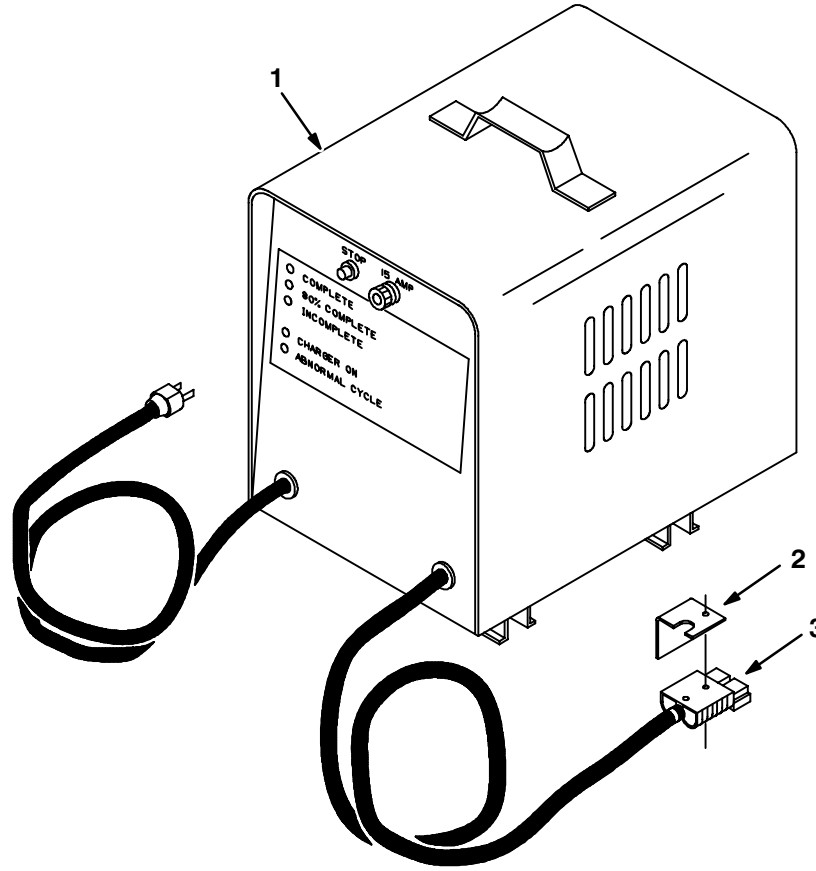

08079/08080

Ref.	Tennant Part No.	Machine Serial Number	Description	Qty.
∇ 1	65570	(xxxxxx-)	Charger, 20A, 60Hz	1
▲ 2	10969	(xxxxxx-)	Bracket, Charger	1
▲ 3	24881	(xxxxxx-)	Connector, Grey, SB50	1
▲	30059	(xxxxxx-)	Fuse	1
▲	65638	(xxxxxx-)	Capacitor	1
▲	65954	(xxxxxx-)	Circuit Breaker	1
▲	65629	(xxxxxx-)	Control Circuit	1
▲	65621	(xxxxxx-)	Power Transformer	1
▲	61837	(xxxxxx-)	Rectifier	1
▲	65626	(xxxxxx-)	Control Circuit Tx2	1
▲	30058	(xxxxxx-)	Fuse Holder	1
▲	49811	(xxxxxx-)	Triac, Charger	1

Fig. 29 – Battery Charger Group, 50 Hz, 230V (220 Ah batteries)

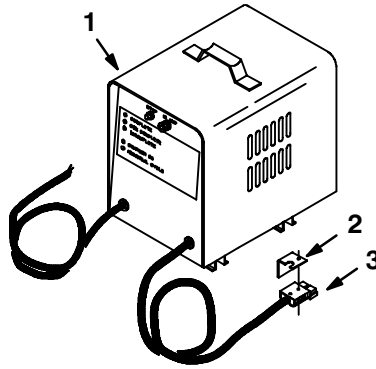

08081/08082

Ref.	Tennant Part No.	Machine Serial Number	Description	Qty.
▽ 1	65572	(xxxxxx-)	Charger, 20A, 50Hz, 230V	1
▲ 2	10969	(xxxxxx-)	Bracket, Charger	1
▲ 3	24881	(xxxxxx-)	Connector, Grey, SB50	1
▲	65958	(xxxxxx-)	Condenser	1
▲	65632	(xxxxxx-)	A.C. Fuse 10Amp	1
▲	30058	(xxxxxx-)	Fuse Holder	1
▲	61837	(xxxxxx-)	Rectifier Assembly	1
▲	65959	(xxxxxx-)	Control Transformer	1
▲	65634	(xxxxxx-)	Transformer	1
▲	65954	(xxxxxx-)	Circuit Breaker	1
▲	65620	(xxxxxx-)	Charger Control Assembly	1

Fig. 30 – Battery Charger Group, 50 Hz, 245V (220 Ah batteries)

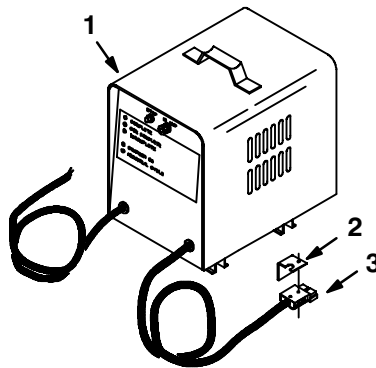

10179/08082

Ref.	Tennant Part No.	Machine Serial Number	Description	Qty.
▽ 1	78550	(xxxxxx-)	Charger, 20A, 50Hz, 245V	1
▲ 2	10969	(xxxxxx-)	Bracket, Charger	1
▲ 3	24881	(xxxxxx-)	Connector, Grey, SB50	1
▲	65958	(xxxxxx-)	Condenser	1
▲	65632	(xxxxxx-)	A.C. Fuse 10Amp	1
▲	30058	(xxxxxx-)	Fuse Holder	1
▲	61837	(xxxxxx-)	Rectifier Assembly	1
▲	65959	(xxxxxx-)	Control Transformer	1
▲	65724	(xxxxxx-)	Power Tran	1
▲	65954	(xxxxxx-)	Circuit Breaker	1
▲	65620	(xxxxxx-)	Charger Control Assembly	1

Fig. 31 – Battery Charger Group, 60 Hz (305 Ah batteries)

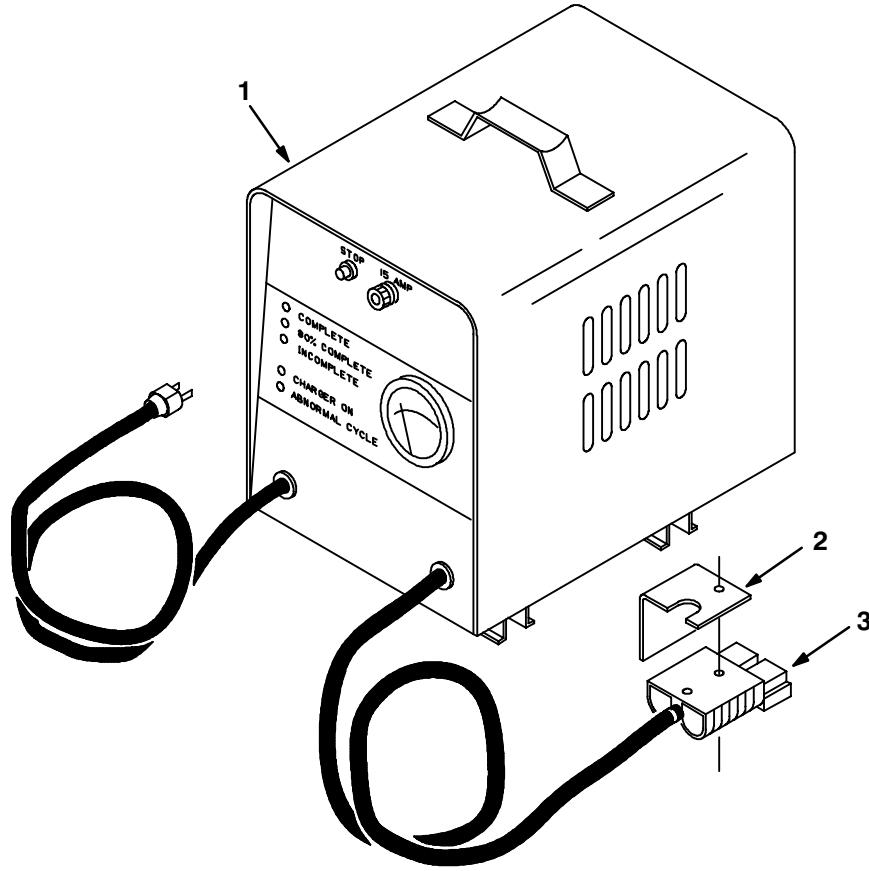

08083/08084

Ref.	Tennant Part No.	Machine Serial Number	Description	Qty.
∇ 1	65571	(xxxxxx-)	Charger, 30A, 60Hz	1
▲ 2	65568	(xxxxxx-)	Bracket, Charger	1
▲ 3	22892	(xxxxxx-)	Connector, Grey, SB175	1
▲	38889	(xxxxxx-)	Ammeter	1
▲	30059	(xxxxxx-)	A.C. Fuse	1
▲	30058	(xxxxxx-)	Fuse Holder	1
▲	65613	(xxxxxx-)	Condensor, 12.5 mfd	1
▲	65619	(xxxxxx-)	Circuit Breaker	1
▲	65629	(xxxxxx-)	Control Circuit	1
▲	65626	(xxxxxx-)	Control Circuit Tx2	1
▲	65628	(xxxxxx-)	Power Transformer	1
▲	49811	(xxxxxx-)	Triac, Charger	1
▲	65630	(xxxxxx-)	Varistor	1

Fig. 32 – Battery Charger Group, 50 Hz (305 Ah batteries)

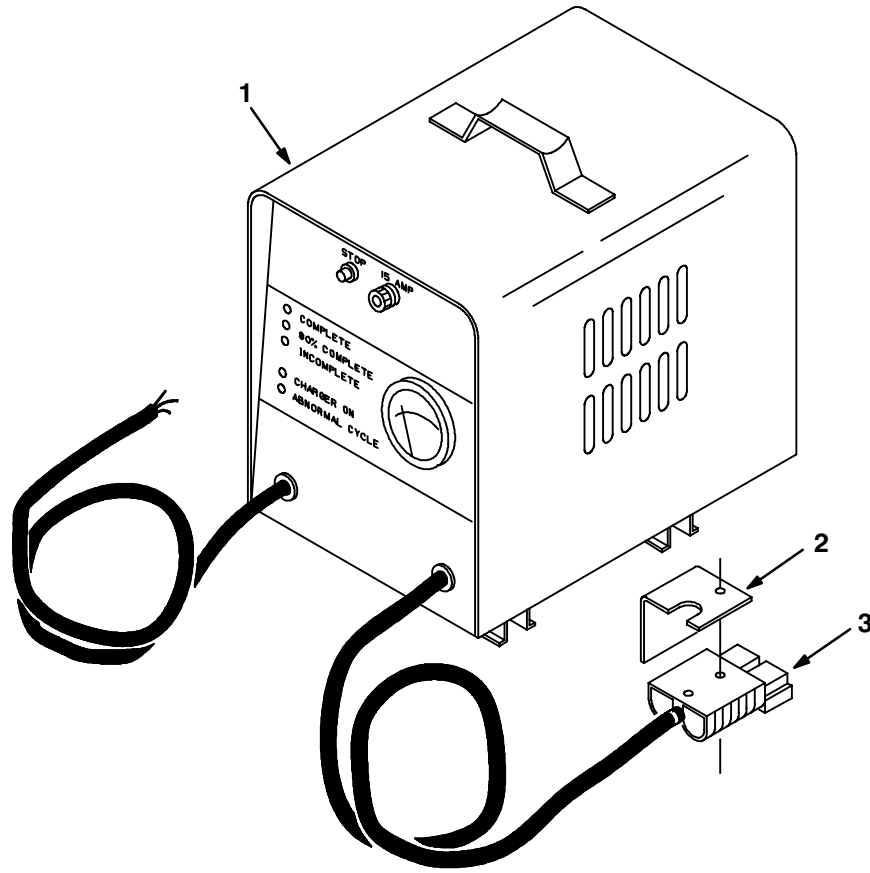

08085/08086

Ref.	Tennant Part No.	Machine Serial Number	Description	Qty.
∇ 1	65573	(xxxxxx-)	Charger, 30A, 50Hz	1
▲ 2	65568	(xxxxxx-)	Bracket, Charger	1
▲ 3	22892	(xxxxxx-)	Connector, Grey, SB175	1
▲	38889	(xxxxxx-)	Ammeter	1
▲	65613	(xxxxxx-)	Condenser 12.5Mfd	1
▲	65614	(xxxxxx-)	A.C. Fuse 15Amp	1
▲	30058	(xxxxxx-)	Fuse Holder	1
▲	65616	(xxxxxx-)	Diode	1
▲	65959	(xxxxxx-)	Control Transformer	1
▲	65618	(xxxxxx-)	Transformer	1
▲	65619	(xxxxxx-)	Circuit Breaker	1
▲	65620	(xxxxxx-)	Charger Control Assembly	1

Fig. 33 – Heavy Duty Battery Kit, Wet, 1480

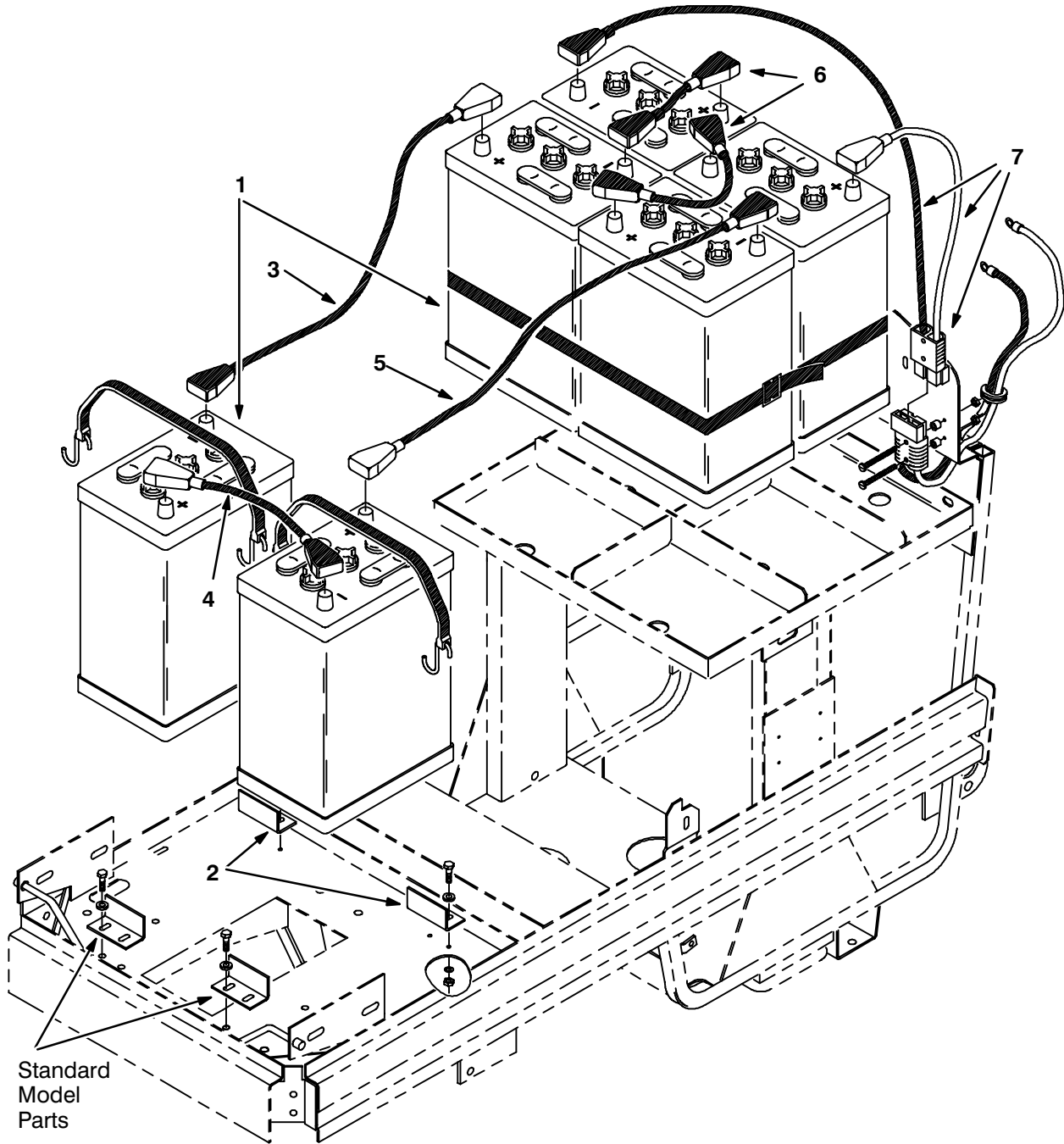

05094/04210

Ref.	Tennant Part No.	Machine Serial Number	Description	Qty.
▽	05652	(000000–)	Battery Kit, 36 V, 305 Ah, Wet	1
▲	1 10138	(000000–)	Battery, 6 V, Wet	6
▲	2 24843	(000000–)	Angle, Battery Stop	2
▲	3 63757	(000000–)	Cable, Battery	1
▲	4 05251	(000000–)	Cable, Battery	1
▲	5 05252	(000000–)	Cable, Battery	1
▲	6 63755	(000000–)	Cable, Battery	2
▲	7 05671	(000000–)	Cable, Battery	1

Fig. 34 – Heavy Duty Battery Kit, Dry, 1480

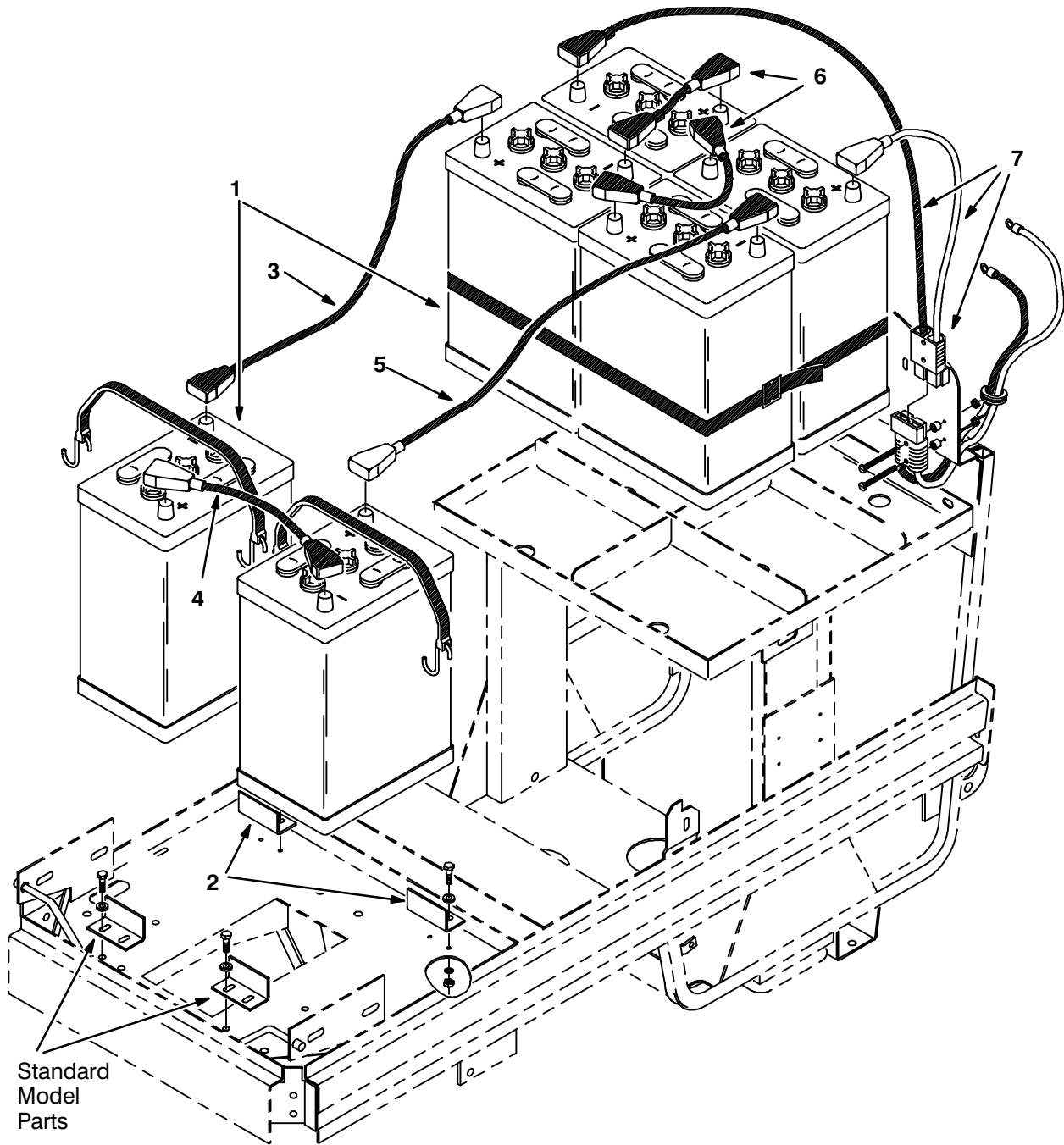

05095/04210

Ref.	Tennant Part No.	Machine Serial Number	Description	Qty.
∇	11568	(000000–)	Battery Kit, 36 V, 305 Ah, Dry	1
▲	1 10140	(000000–)	Battery, 6 V, Dry	6
▲	2 24843	(000000–)	Angle, Battery Stop	4
▲	3 63757	(000000–)	Cable, Battery	1
▲	4 05251	(000000–)	Cable, Battery	1
▲	5 05252	(000000–)	Cable, Battery	1
▲	6 63755	(000000–)	Cable, Battery	2
▲	7 05671	(000000–)	Cable, Battery	1

Fig. 35 – Battery Tray Group, 1465

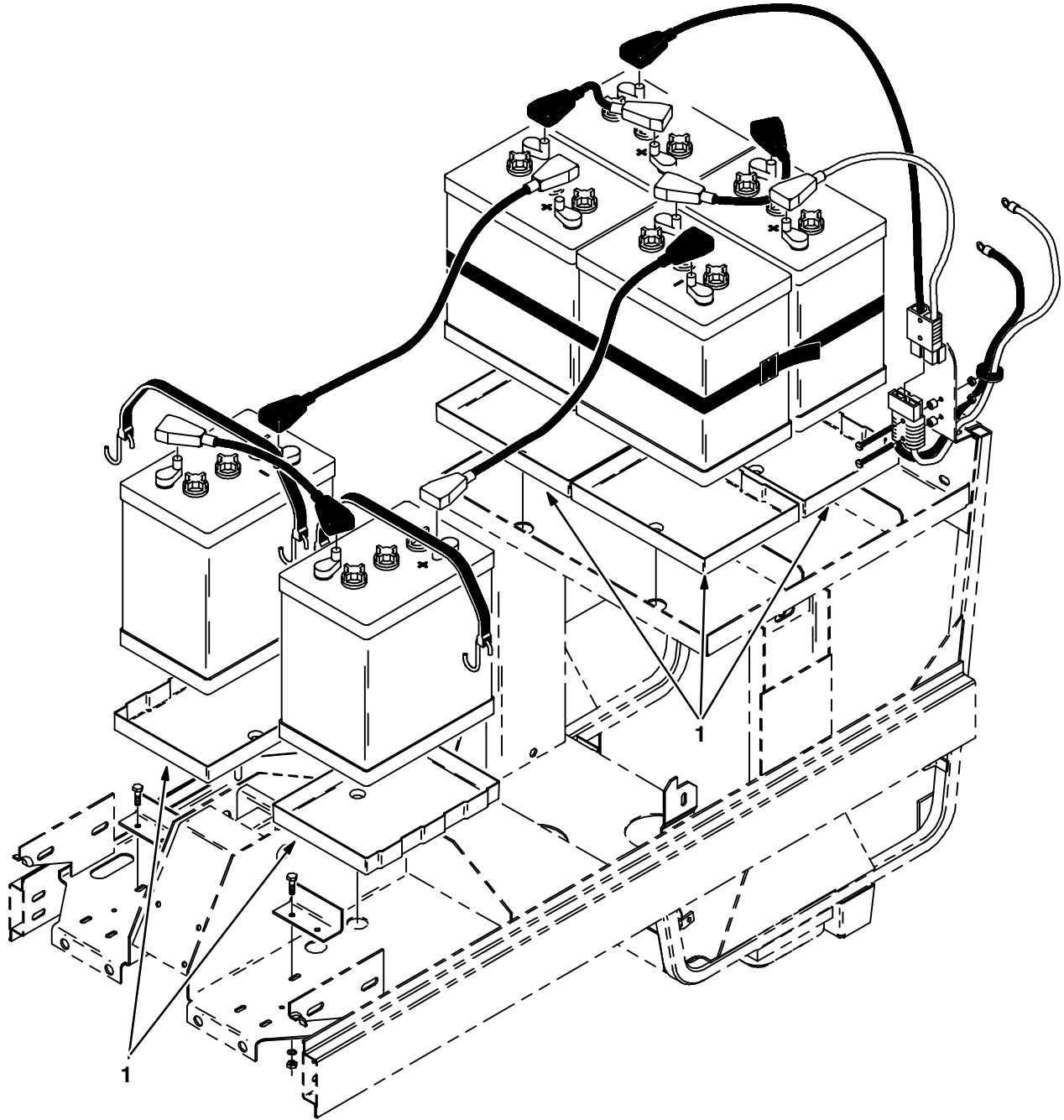

05381/04769

Ref.	Tennant Part No.	Machine Serial Number	Description	Qty.
1	04900	(000000–)	Liner, Tray Battery	6

Fig. 36 – Battery Tray Group, 1480, 1490

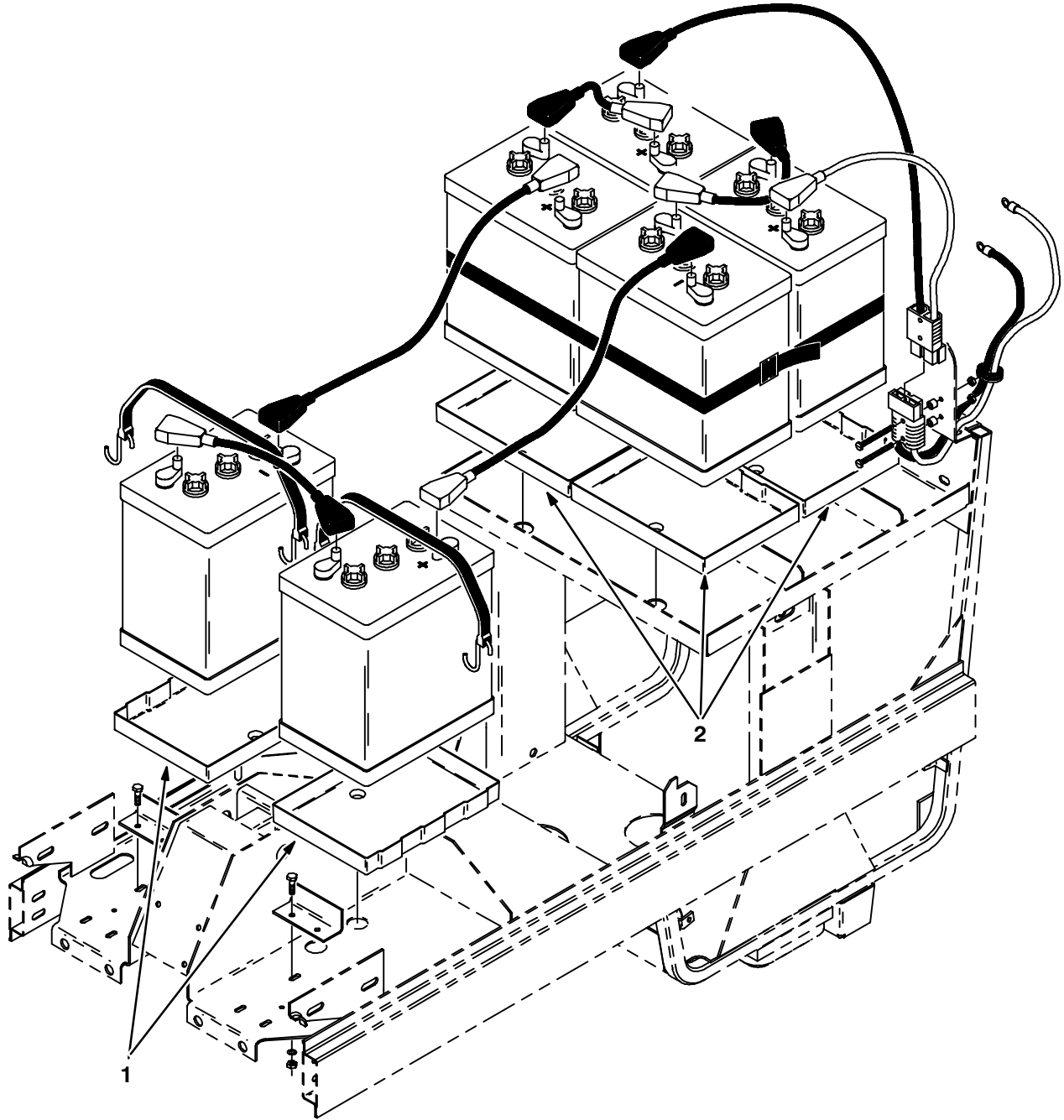

05383/04769

Ref.	Tennant Part No.	Machine Serial Number	Description	Qty.
1	04900	(000000–)	Liner, Tray Battery	2
2	04899	(000000–)	Liner, Tray Battery	4

Fig. 37 – Heavy Duty Battery Tray Group, 1480, 1490

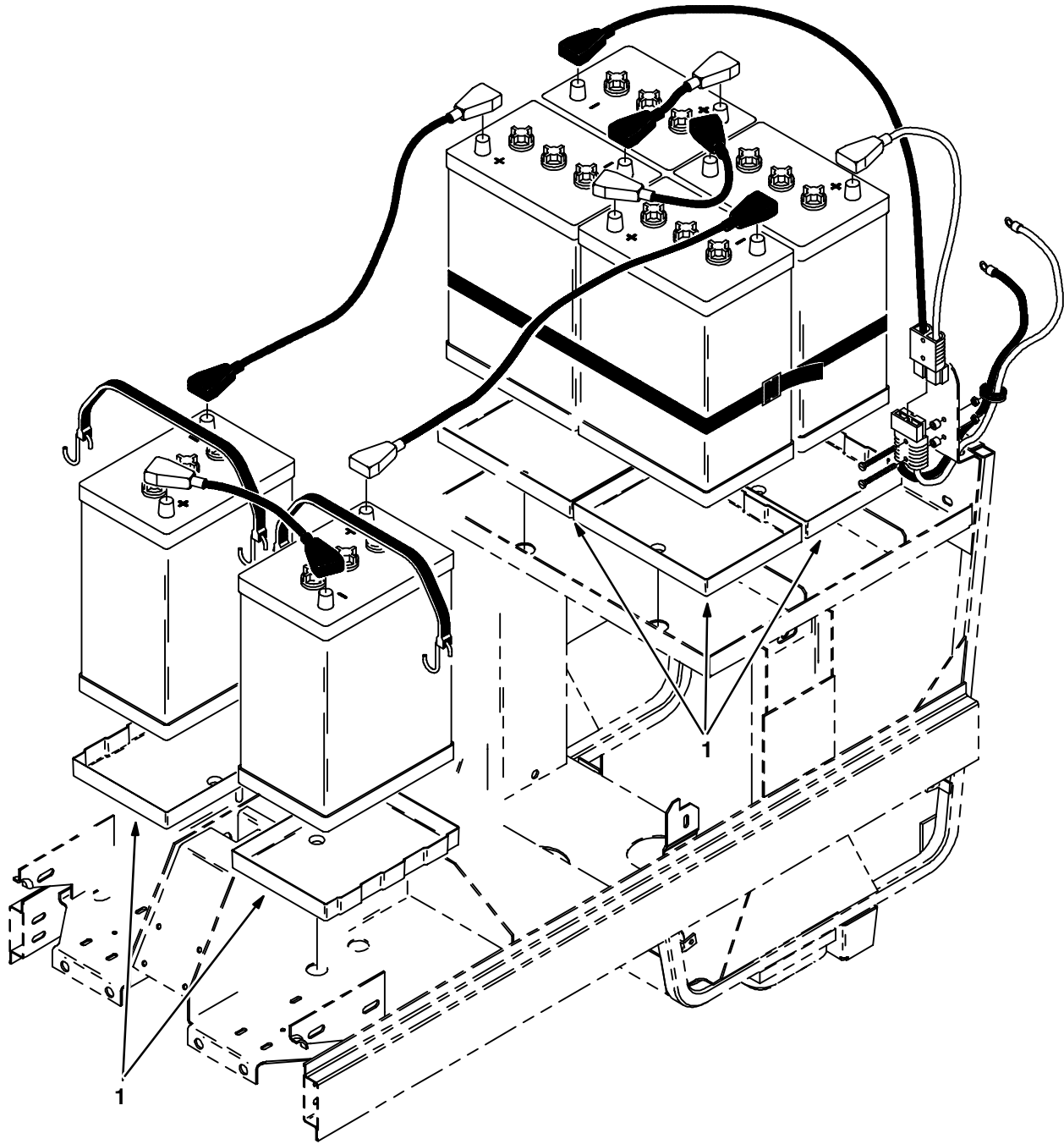

05412/05371

Ref.	Tennant Part No.	Machine Serial Number	Description	Qty.
1	04899	(000000–)	Liner, Tray Battery	6

Fig. 38 – Power Wand Hose Assembly

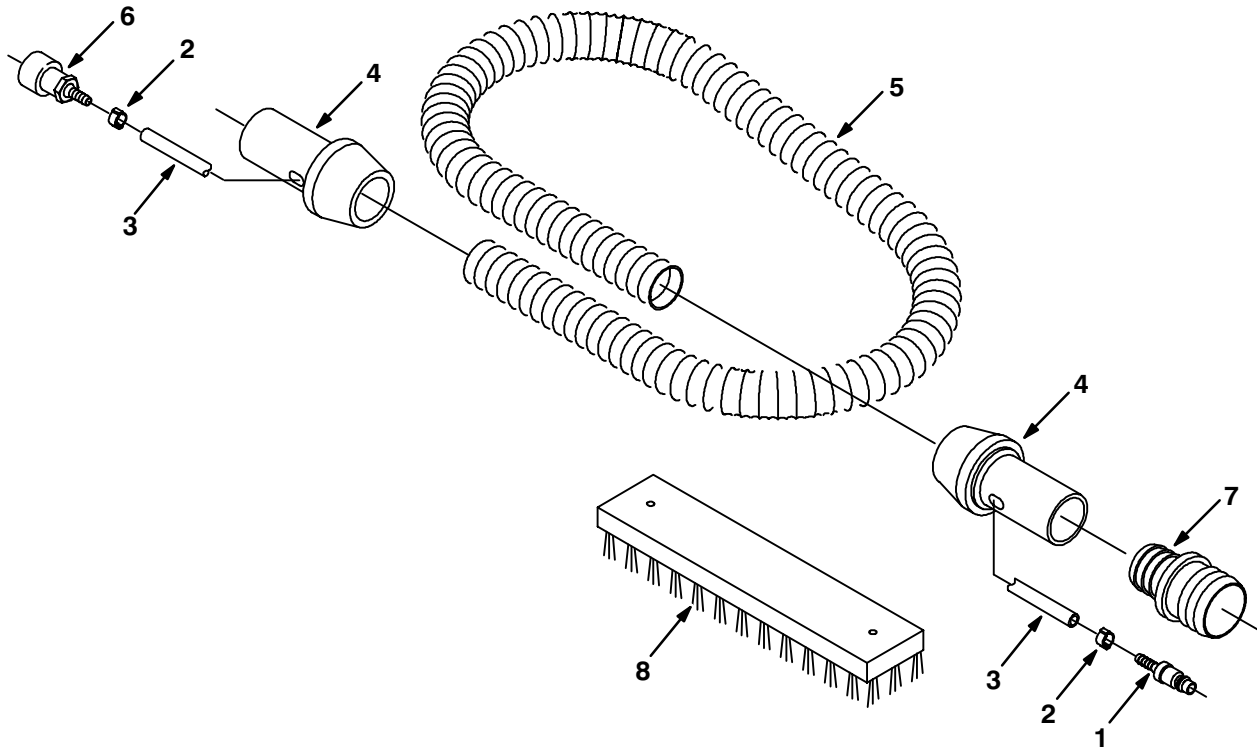

08073/08042

NOTE: Power Wand Kit, TENNANT Part Number 65578, includes Fig. 38, Fig. 39, Fig. 40, and Fig. 41.

Ref.	Tennant Part No.	Machine Serial Number	Description	Qty.
▽	65341	(000000–) Hose Assembly	1
▲	1 578318	(000000–) Fitting, Quick Disconnect	1
▲	2 578160	(000000–) Clamp, Hose	2
▲	3 578820	(000000–) Hose	1
▲	4 578072	(000000–) Cuff, Swivel	2
▲	5 578276	(000000–) Hose, Vacuum	1
▲	6 578071	(000000–) Fitting, Quick Disconnect	1
	7 12694	(000000–) Fitting, Plastic	1
	8 65582	(000000–) Brush, Wand AB	1

Fig. 39 – Power Wand Assembly

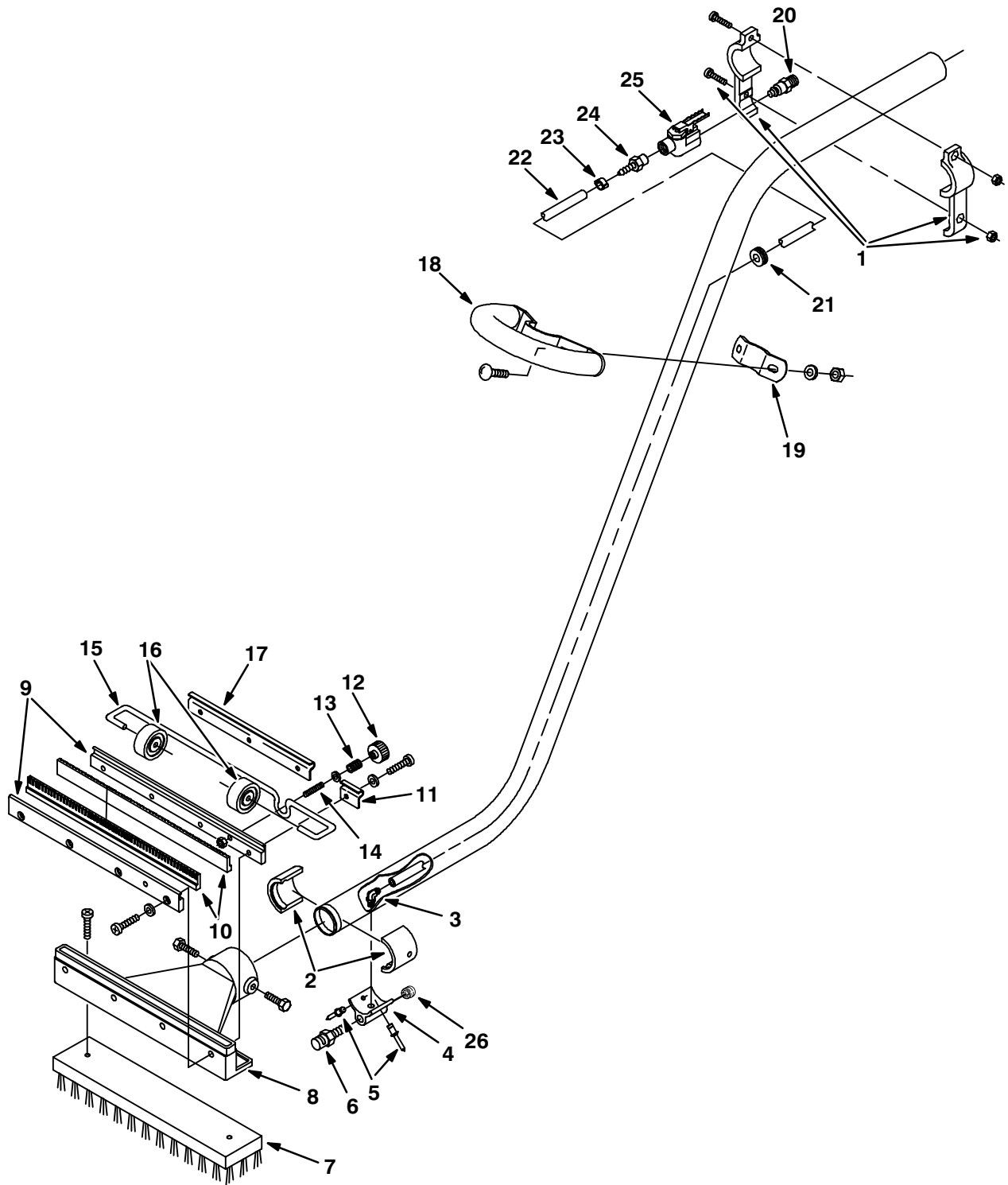

Fig. 39 – Power Wand Assembly

NOTE: Power Wand Kit, TENNANT Part Number 65578, includes Fig. 38, Fig. 39, Fig. 40, and Fig. 41.

Ref.	Tennant Part No.	Machine Serial Number	Description	Qty.
▽	65340	(000000–) Wand Assembly	1
▲ 1	578077	(000000–) Bracket, Valve Mounting	1
▲ 2	578061	(000000–) Adapter, Head	2
▲ 3	578214	(000000–) Fitting, 90° Elbow	1
▲ 4	579112	(000000–) Adapter, Nozzle	1
▲ 5	579198	(000000–) Rivet, Pop	2
▲ 6	578066	(000000–) Nozzle, Spray	1
▲ 7	578073	(000000–) Brush, Wand, Nylon	1
▲ 8	578063	(000000–) Head, Wand	1
▲ 9	578078	(000000–) Strip, Retainer	2
▲ 10	578074	(000000–) Blade, Squeegee	2
▲ 11	578124	(000000–) Bracket, Axle	1
▲ 12	578439	(000000–) Knob, Adjustable, Squeegee	1
▲ 13	578228	(000000–) Spring, Compression	1
▲ 14	578143	(000000–) Stud, Adjustable	1
▲ 15	578126	(000000–) Axle, Wand	1
▲ 16	578125	(000000–) Wheel, Guide	2
▲ 17	578123	(000000–) Bracket, Axle	1
▲ 18	578155	(000000–) Handle, Wand	1
▲ 19	578154	(000000–) Bracket, Handle Mounting	1
▲ 20	578091	(000000–) Fitting, Quick Disconnect	1
▲ 21	578164	(000000–) Grommet	1
▲ 22	578821	(000000–) Hose, Solution	1
▲ 23	578161	(000000–) Clamp, Hose	2
▲ 24	578094	(000000–) Fitting, Straight	1
▲ 25	578064	(000000–) Valve, Water	1
▲ 26	579148	(000000–) Fitting, Plug	1

Fig. 40 – Power Wand Pump and Electrical Group

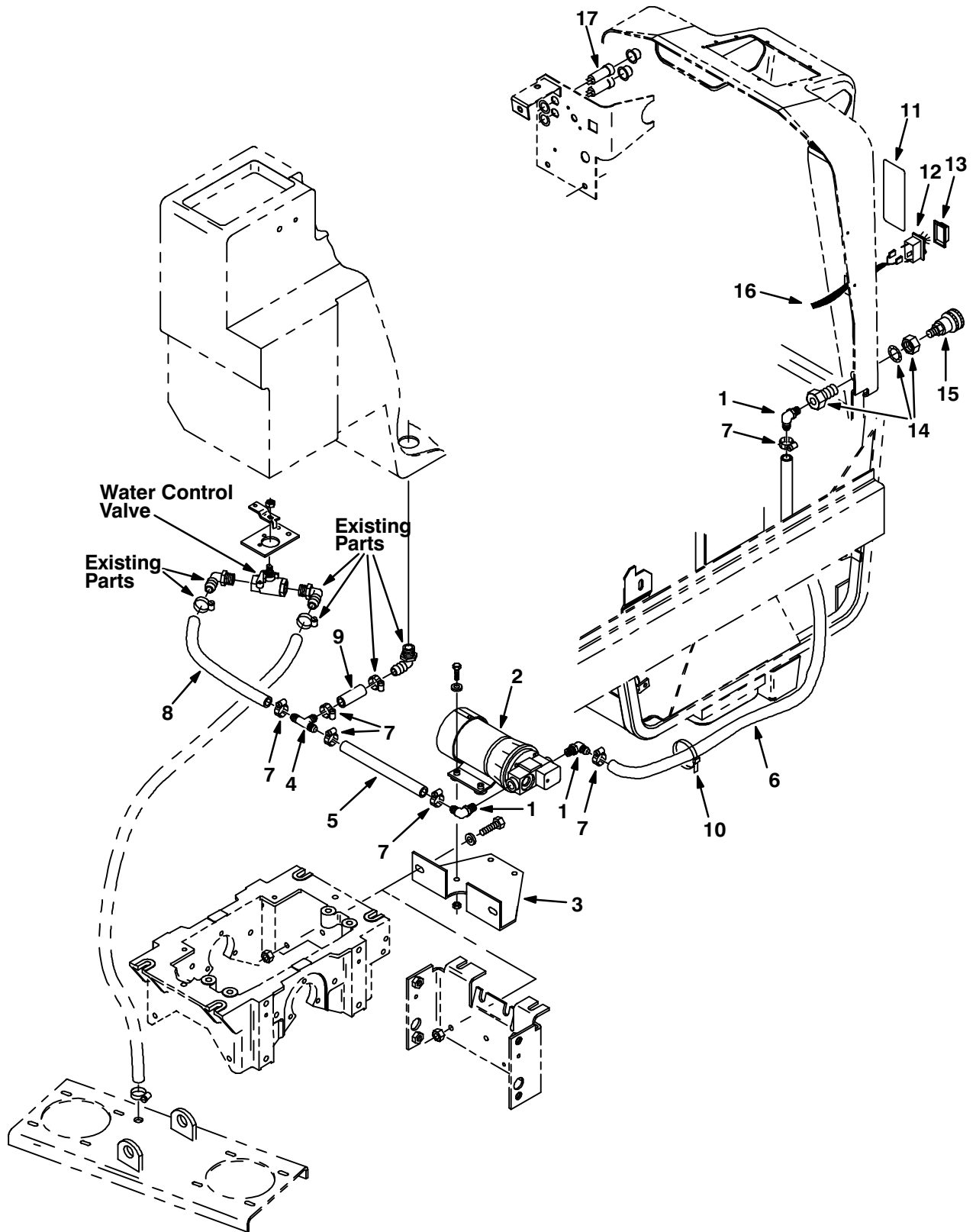
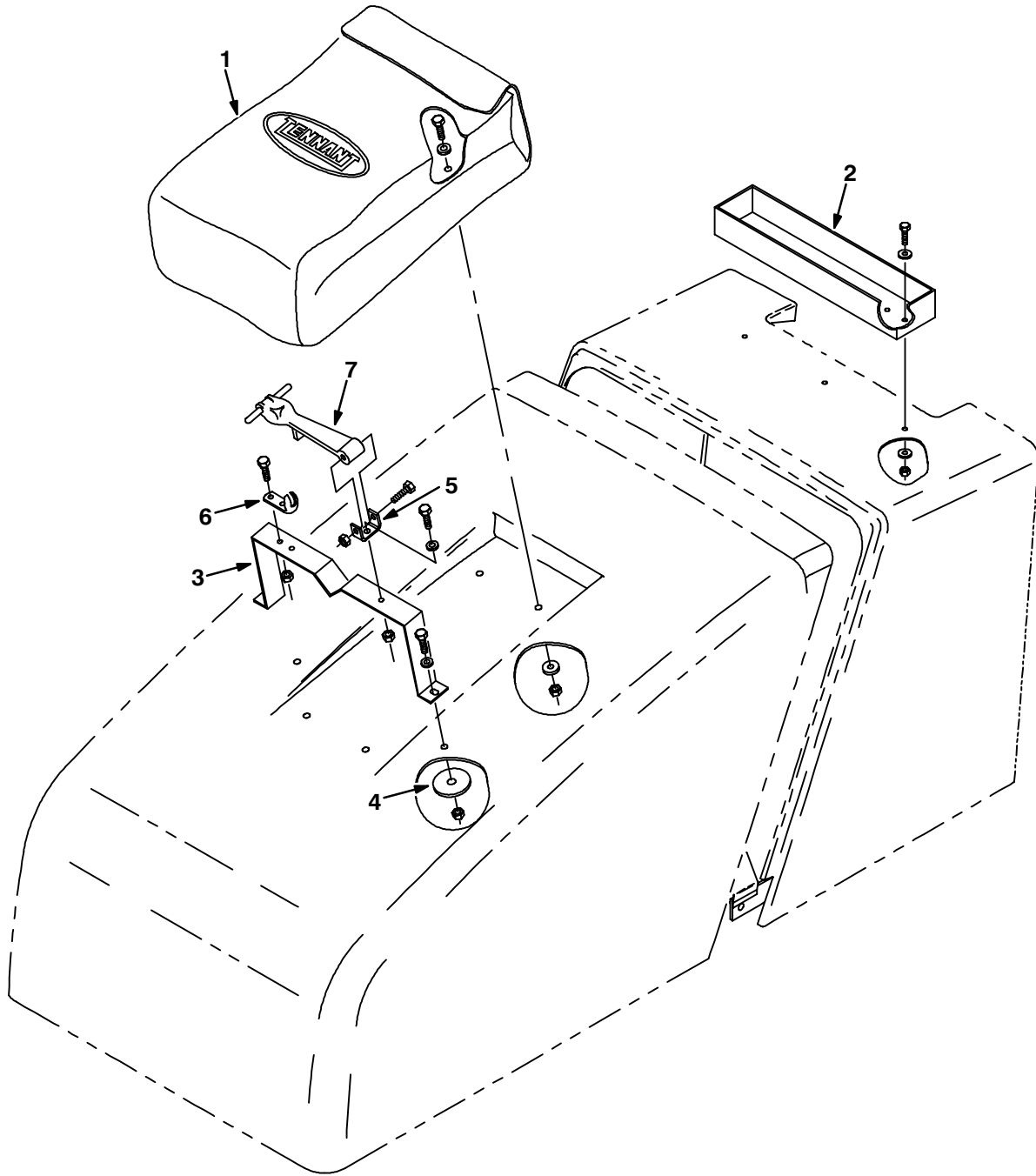

Fig. 40 – Power Wand Pump and Electrical Group

NOTE: Power Wand Kit, TENNANT Part Number 65578, includes Fig. 38, Fig. 39, Fig. 40, and Fig. 41.

Ref.	Tennant Part No.	Machine Serial Number	Description	Qty.
1	65581	(000000–)	Fitting, Barbed Elbow	3
2	65590	(000000–)	Pump Assembly, Power Wand (See Breakdowns)	1
3	61211	(000000–)	Plate, Pump Mount	1
4	63245–1	(000000–)	Fitting, Barbed Tee	1
5	65607	(000000–)	Hose (1465)	1
5	65586	(000000–)	Hose (1480, 1490)	1
6	65587	(000000–)	Hose (1465)	1
6	65588	(000000–)	Hose (1480, 1490)	1
7	54333	(000000–)	Clamp, Worm Drive	6
8	65591	(000000–)	Hose	1
9	65592	(000000–)	Hose	1
10	49266	(000000–)	Tie, Cable	6
11	19800	(000000–)	Label, Solution Control	1
12	65557	(000000–)	Switch, Rocker SPST	1
13	57807	(000000–)	Cover, Rocker Switch Seal	1
14	78122	(000000–)	Fitting, Bulkhead	1
15	65342	(000000–)	Fitting, Quick Disconnect, Female	1
16	61214	(000000–)	Harness, Wire, Pump	1
17	87977	(000000–)	Breaker, Circuit, 7A	1

Fig. 41 – Power Wand Mount Group



08075/07460

NOTE: Power Wand Kit, TENNANT Part Number 65578, includes Fig. 38, Fig. 39, Fig. 40, and Fig. 41.

Ref.	Tennant Part No.	Machine Serial Number	Description	Qty.
1	65580	(000000–)	Bag, Power Wand	1
2	61212	(000000–)	Tray, Wand	1
3	65599	(000000–)	Bracket	1
4	63288	(000000–)	Washer	2
5	40671	(000000–)	Bracket, U	1
6	40670	(000000–)	Catch, Rubber	1
7	75118	(000000–)	Hook, Rubber	1

SECTION 10**CONTENTS**

	Page
Fig. 1 – Electric Motor Breakdown, 10914	10-2
Fig. 2 – Electric Motor Breakdown, 28386	10-4
Fig. 3 – Electric Motor Breakdown, 04922	10-6
Fig. 4 – Electric Motor Breakdown, 04656	10-7
Fig. 5 – Water Pump Breakdown, 10916	10-8
Fig. 6 – Water Pump Breakdown, 65590	10-9

Fig. 1 – Electric Motor Breakdown, 10914

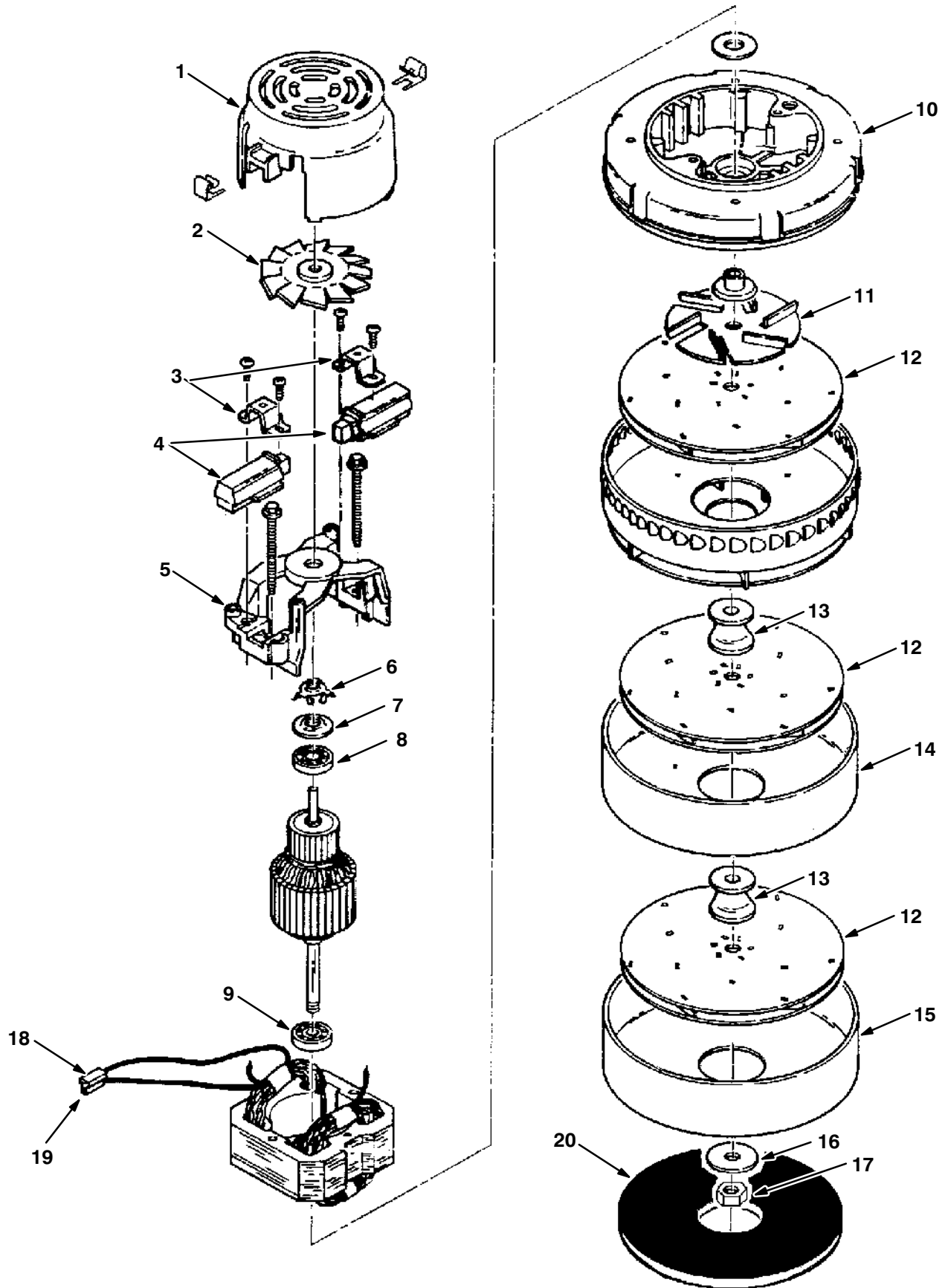

Fig. 1 – Electric Motor Breakdown, 10914

	Ref.	Tenant Part No.	Machine Serial Number	Description	Qty.
▽		10914	(000000–) Motor, Electric	1
▲	1	37926	(000000–) Housing	1
▲	2	37923	(000000–) Fan	1
▲	3	01982	(000000–) Clamp	2
▲	4	11756	(000000–) Brush Assembly	2
▲	5	01983	(000000–) Bracket, Connector	1
▲	6	01856	(000000–) Spring	1
▲	7	37909	(000000–) Disc	1
▲	8	01842	(000000–) Bearing	1
▲	9	01837	(000000–) Bearing	1
▲	10	01970	(000000–) Bracket, Fan	1
▲	11	01971	(000000–) Fan	1
▲	12	18628	(000000–) Fan, Vacuum	3
▲	13	18630	(000000–) Spacer	2
▲	14	61297	(000000–) Fan, Stationary	1
▲	15	18631	(000000–) Shell, Fan	1
▲	16	18632	(000000–) Washer	1
▲	17	37929	(000000–) Nut	1
▲	18	10925	(000000–) Connector	1
▲	19	10926	(000000–) Terminal, Female	2
▲	20	10912	(000000–) Seal	1

Fig. 2 – Electric Motor Breakdown, 28386

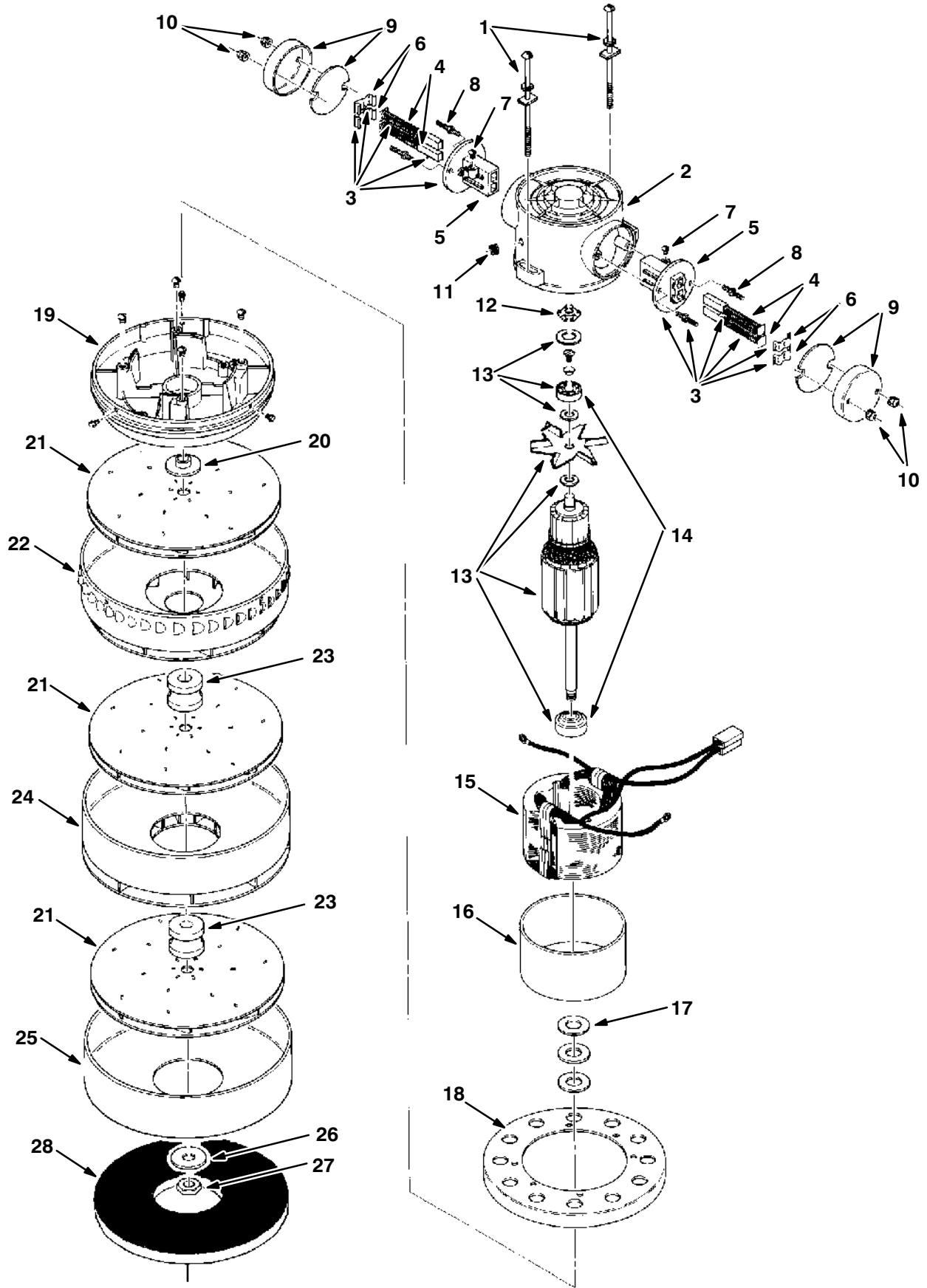
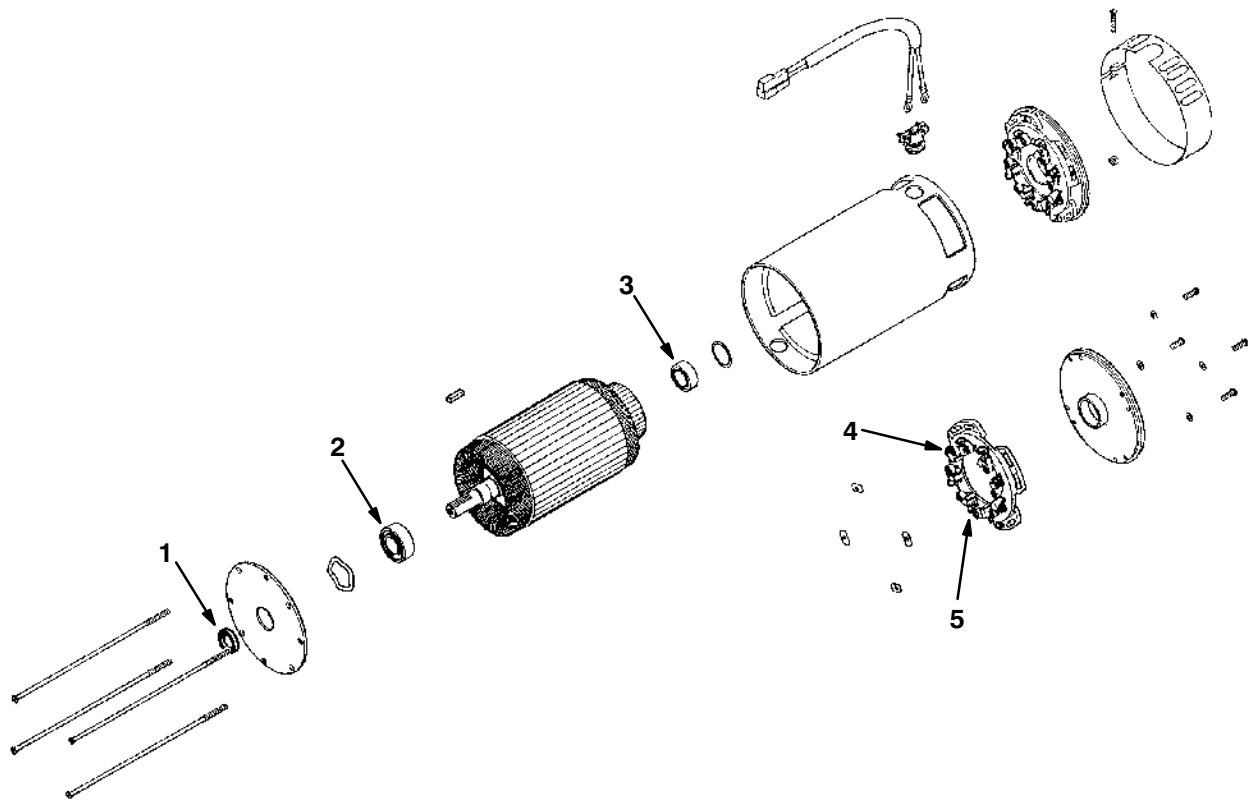

Fig. 2 – Electric Motor Breakdown, 28386

	Ref.	Tenant Part No.	Machine Serial Number	Description	Qty.
▽		28386	(000000–) Motor, Electric	1
▲	1	01981	(000000–) Screw	2
▲	2	01848	(000000–) Bracket	1
▲▽	3	32324	(000000–) Brush Assembly	2
▲▲	4	37925	(000000–) Brush and Spring	2
▲▲	5	01972	(000000–) Holder, Brush	1
▲▲	6	01973	(000000–) Clip, Brush Assembly	2
▲	7	38303	(000000–) Screw	2
▲	8	01974	(000000–) Stud	4
▲	9	38327	(000000–) Cap	2
▲	10	01975	(000000–) Nut	4
▲	11	01976	(000000–) Bushing	1
▲	12	01856	(000000–) Spring	1
▲▽	13	01841	(000000–) Armature	1
▲▲	14	38438	(000000–) Bearing Kit	1
▲	15	01978	(000000–) Field	1
▲	16	01979	(000000–) Band	1
▲	17	01980	(000000–) Washer	1
▲	18	38362	(000000–) Shell	1
▲	19	01854	(000000–) Bracket	1
▲	20	45419	(000000–) Spacer	1
▲	21	45420A	(000000–) Fan, Rotating	3
▲	22	45418A	(000000–) Fan, Stationary	1
▲	23	45421	(000000–) Spacer	2
▲	24	45422A	(000000–) Fan, Stationary	1
▲	25	45424A	(000000–) Shell	1
▲	26	45423	(000000–) Washer	1
▲	27	37939	(000000–) Nut	1
▲	28	10912	(000000–) Seal	1
▲		10925	(000000–) Connector	1
▲		10926	(000000–) Terminal	2

Fig. 3 – Electric Motor Breakdown, 04922



05208/00169

Ref.	Tennant Part No.	Machine Serial Number	Description	Qty.
▽	04922	(000000–) Motor, Electric	1
▲	1 37637	(000000–) Seal, Oil	1
▲	2 18626	(000000–) Bearing	1
▲	3 38378	(000000–) Bearing	1
▲	4 11757	(000000–) Spring, Brush	4
▲	5 37638	(000000–) Brush Assembly	4

Fig. 4 – Electric Motor Breakdown, 04656

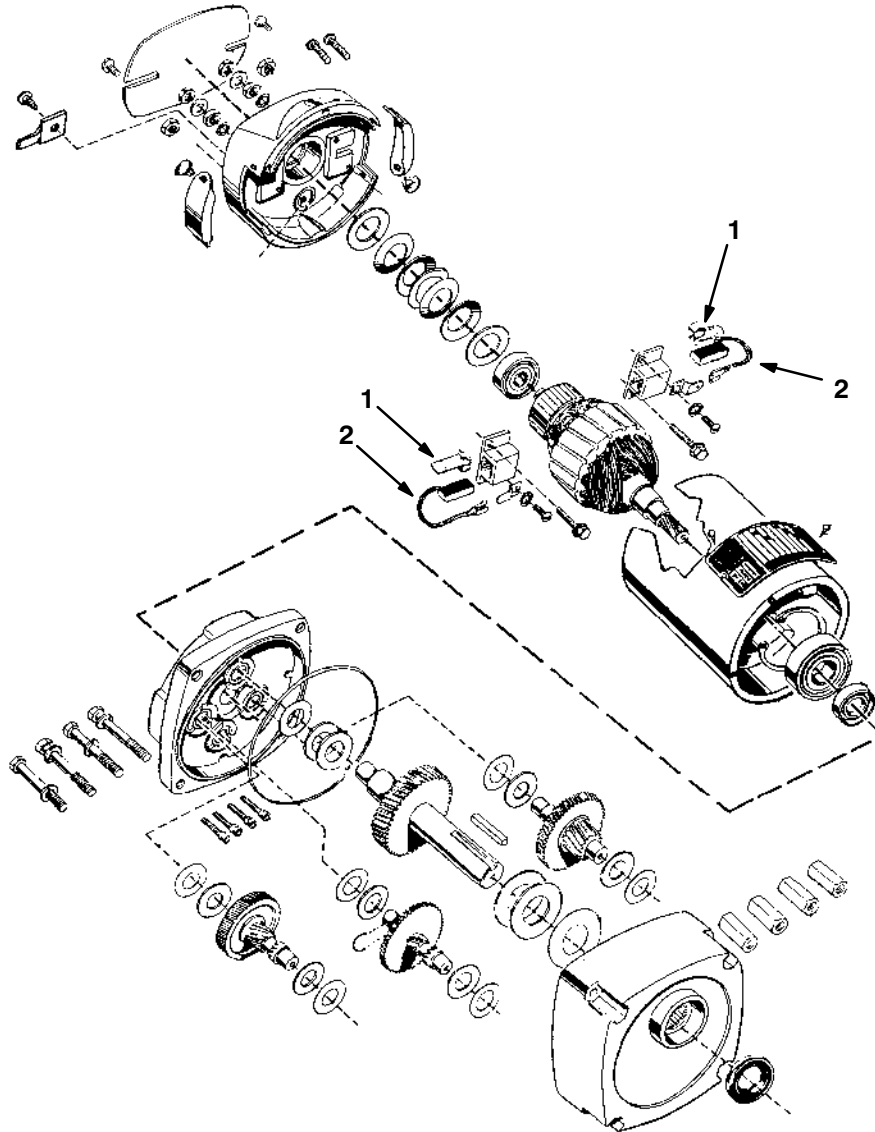

05196/06452

	Ref.	Tennant Part No.	Machine Serial Number	Description	Qty.
▽		04656	(000000–)	Motor, Electric	1
▲	1	11751	(000000–)	Spring, Brush	2
▲	2	11752	(000000–)	Brush, Pigtail, Clip	2

Fig. 5 – Water Pump Breakdown, 10916

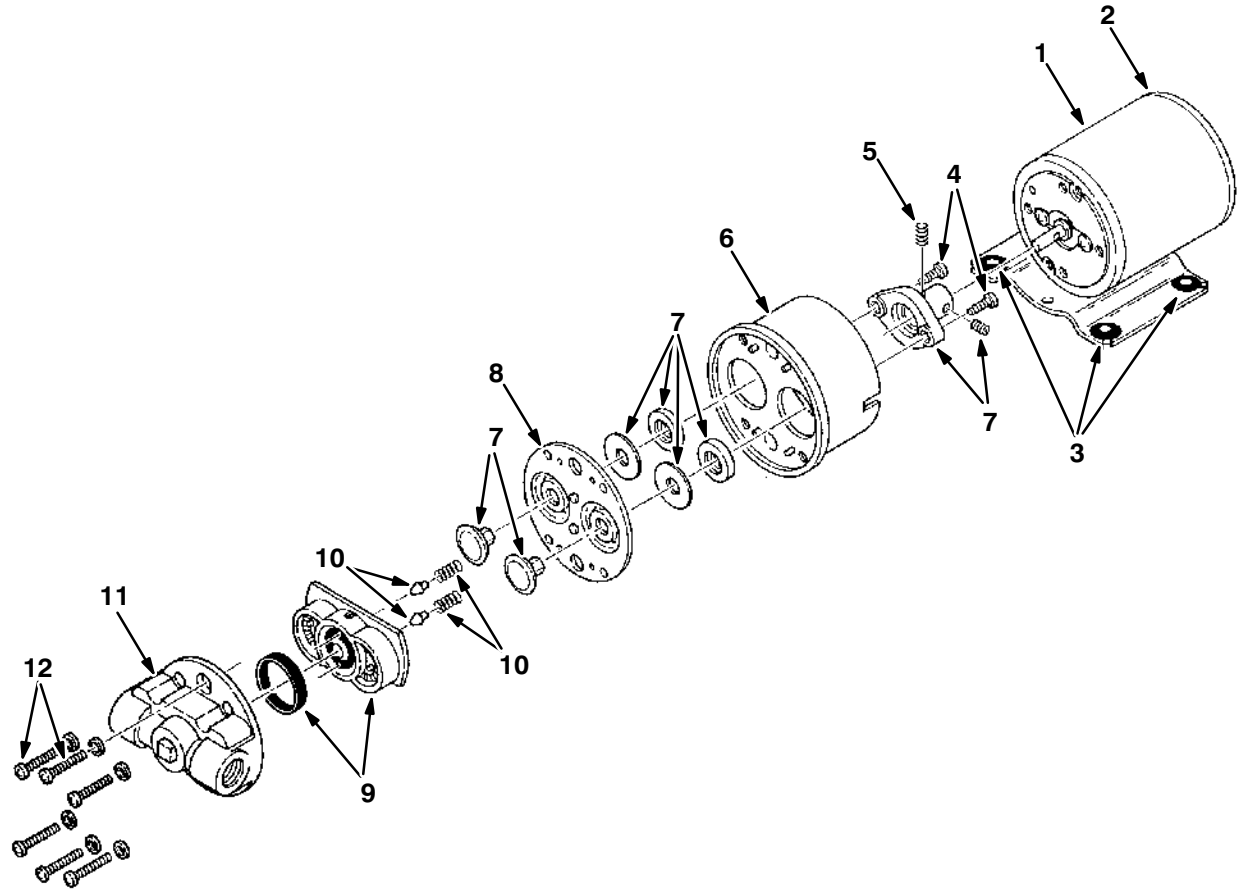

05207/05092

Ref.	Tennant Part No.	Machine Serial Number	Description	Qty.
▽	10916	(000000–)	Pump, Water	1
▲▽	1 65700	(000000–)	Motor, 36V DC	1
▲▲	2 65701	(000000–)	Brush, Endbell	1
▲▲	65702	(000000–)	Brush Kit	1
▲	3 65703	(000000–)	Grommets	4
▲▽	65710	(000000–)	Pump Head Assembly	1
▲▲	4 65667	(000000–)	Cam/Bearing Screw	2
▲▲	5 65668	(000000–)	Cam/Bearing Set Screw	1
▲▲	65705	(000000–)	Cam/Bearing Set	1
▲▲	6 49901	(000000–)	Bearing Cover	1
▲▲	7 65706	(000000–)	Piston, Inner/Out	1
▲▲	8 65707	(000000–)	Diaphragm Kit	1
▲▲	9 65708	(000000–)	Check Valve	1
▲▲	10 65709	(000000–)	Bypass, Poppet	1
▲▲	11 49886	(000000–)	Housing, Pump	1
▲▲	12 65675	(000000–)	Pump Screws	6

Fig. 6 – Water Pump Breakdown, 65590

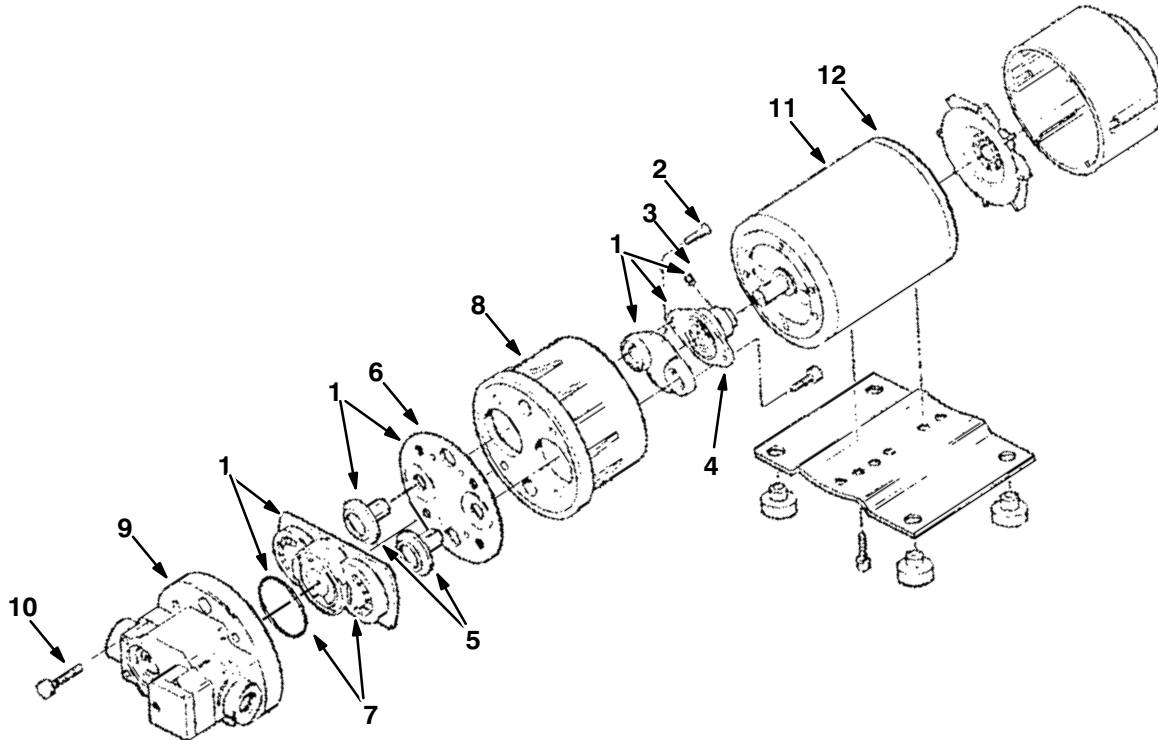

07525/07526

Ref.	Tennant Part No.	Machine Serial Number	Description	Qty.
▽	65590	(000000–) Pump, Water	1
▲	1	65678	(000000–) Seal Kit	1
▲	2	65667	(000000–) Cam/Bearing Screw	1
▲	3	65668	(000000–) Cam/Bearing Set Screw	1
▲	4	65669	(000000–) Cam/Bearing Kit	1
▲	5	65671	(000000–) Piston Inner/Out	1
▲	6	65672	(000000–) Diaphragm Kit	1
▲	7	65673	(000000–) Check Valve Assembly	1
▲	8	65670	(000000–) Bearing Cover	1
▲	9	65674	(000000–) Switch Assembly/Housing	1
▲	10	65675	(000000–) Pump Screws	1
▲	11	65676	(000000–) Motor, 36VDC	1
▲	12	65677	(000000–) Brush/Rectifier Assembly	1
▲	10923	(000000–)) Connector, 2 Conductor	1
▲	10924	(000000–)) Terminal, Male	2
▲	10917	(000000–)) Seal, Connector	2

SECTION 11

CONTENTS

	PAGE
PART NUMBER TO PAGE NUMBER CROSS REFERENCE LIST	11-2

CROSS REFERENCE

PART NUMBER TO PAGE NUMBER CROSS REFERENCE LIST

Part Number	Page Number	Part Number	Page Number
00500-15	6-19, 7-19	04702	6-9, 7-9, 8-7
00911	6-19, 7-19, 8-15, 9-15, 9-17	04704	6-19, 7-19, 8-15
00913	9-15, 9-17	04706	9-19, 9-21
00926	6-16, 7-16, 8-12	04707	9-15, 9-17
00927	8-15	04710	9-15, 9-17
00928	6-19, 7-19, 9-31	04713	9-17
01275	8-23	04720	6-19, 7-19, 8-15
01837	10-3	04740	9-23, 9-25
01841	10-5	04745	9-17
01842	10-3	04746	6-19, 7-19, 8-15
01848	10-5	04752	6-41, 7-41, 8-32
01854	10-5	04760	6-31, 7-31, 8-25
01856	10-3, 10-5	04761	6-31, 7-31
01970	10-3	04762	6-31, 7-31, 8-25
01971	10-3	04763	6-31, 7-31, 8-25
01972	10-5	04765	6-31, 7-31, 8-25
01973	10-5	04766	6-31, 7-31, 8-25
01974	10-5	04767	6-31, 7-31, 8-25
01975	10-5	04808	6-41, 7-41, 8-32
01976	10-5	04809	6-41, 7-41, 8-32
01978	10-5	04819	6-41, 7-41
01979	10-5	04832	6-21, 7-21, 8-17
01980	10-5	04836	6-21, 6-27, 6-29, 7-21, 7-27, 7-29, 8-17, 8-23
01981	10-5	04843	6-39, 7-39, 8-31
01982	10-3	04844	6-41, 7-41, 8-32
01983	10-3	04845	6-39, 7-39, 8-31
02076	6-29, 7-29, 8-23	04846	6-39, 7-39, 8-31
02892	9-7, 9-8, 9-9, 9-33, 9-35	04849	6-37, 7-37
02942	9-19, 9-21	04852	6-41, 7-41
04401	6-19, 7-19, 8-15	04853	6-37, 7-37
04618	9-15, 9-17	04854	6-37, 7-37
04619	9-15, 9-17	04856	6-37, 7-37
04620	9-15, 9-17	04869	6-37, 7-37
04625	9-21	04894	6-2, 6-41
04629	9-15, 9-17	04898	6-2, 6-41
04630	9-15, 9-17	04899	9-47, 9-48
04632	9-15, 9-17	04900	9-46, 9-47
04636	9-17	04916	7-2, 7-41
04637	9-19, 9-21	04919	7-2, 7-41
04640	9-21	04920	6-15, 7-15, 8-11
04641	9-21	04921	6-15, 7-15, 8-11
04642	9-15, 9-17	04922	6-16, 7-16, 8-12, 10-6
04644	9-21	04924	6-15, 7-15, 8-11
04645	9-15, 9-17	04927	6-15, 6-16, 7-15, 7-16, 8-11, 8-12
04656	6-19, 7-19, 8-15, 9-15, 9-17, 10-7	04928	6-15, 6-16, 7-15, 7-16, 8-11, 8-12
04657	6-17, 7-17, 8-13	04929	7-15
04658	6-17, 7-17, 8-13	04942	6-15, 7-15, 8-11
04664	9-17	04944	7-5
04665	9-19, 9-21	04945	6-5, 7-5
04671	6-19, 7-19, 8-15	04957	6-33, 7-33, 8-27
04672	6-19, 7-19, 8-15	04993	6-5
04684	6-27, 6-29, 7-27, 7-29	05006	6-8, 6-9
04685	6-35, 7-35, 8-29	05014	6-21
04691	6-43, 7-43	05015	6-21
04693	6-43, 7-43, 8-35	05016	7-21, 8-17
04701	9-11		

CROSS REFERENCE

Part Number	Page Number	Part Number	Page Number
05017	7-21, 8-17	05506	9-31
05018	6-15, 7-15, 8-11	05552	9-31
05019	6-15, 7-15, 8-11	05567	6-23, 7-23, 8-19, 9-23, 9-25, 9-27
05027	6-33, 7-33, 8-27	05572	6-19, 7-19, 8-15
05033	6-3	05573	7-5, 7-7, 8-5
05034	6-3	05574	7-5, 7-7, 8-5
05036	7-3	05575	6-5, 6-7
05038	7-3	05578	9-11
05045	7-8	05579	9-11
05046	7-8	05582	6-19, 6-31, 7-19, 7-31
05047	6-8	05584	9-11
05048	6-8	05594	9-11
05050	6-13	05604	6-19, 7-19, 8-15
05058	7-13	05611	6-31, 7-31, 8-25
05070	6-5, 7-5	05612	6-16, 7-16, 8-12
05072	6-5, 6-7	05621	9-19, 9-21
05073	7-5, 7-7, 8-5	05624	6-39, 7-39, 8-31
05075	6-16	05633	6-43, 7-43, 8-35
05076	7-16	05638	6-43, 7-43, 8-35
05089	6-21, 7-21, 8-17	05639	6-43, 7-43, 8-35
05099	6-39, 7-39, 8-31	05646	6-11
05120	6-37, 7-37	05650	9-2
05127	6-21, 7-21, 8-17	05652	9-44
05134	9-23, 9-25, 9-27	05669	6-25, 7-25, 8-21
05145	6-39, 7-39, 8-31	05670	6-25, 7-25, 8-21
05165	6-21, 7-21, 8-17	05671	6-27, 7-27, 9-44, 9-45
05214	6-13, 7-13, 8-9	05672	6-27, 6-29, 7-27, 7-29
05216	6-21, 7-21, 8-17	05675	6-21, 7-21, 8-17
05218	6-21, 7-21, 8-17	05678	6-37, 7-37
05222	6-13	05681	7-11
05223	6-5, 6-7, 7-5, 7-7, 8-5	05685	6-15, 7-15, 8-11
05233	6-13	05686	6-15, 7-15, 8-11
05236	6-5, 6-7, 7-5, 7-7, 8-5	05711	6-25, 7-25, 8-21
05240	6-13	05712	6-25, 7-25
05241	7-13	05713	9-23, 9-25, 9-27
05244	7-13	05714	6-25, 7-25, 8-21
05247	9-37	05715	6-25
05251	6-27, 7-27, 9-44, 9-45	05716	9-23, 9-25, 9-27
05252	6-27, 7-27, 9-44, 9-45	05717	7-25
05263	9-36	05724	7-3
05264	9-36, 9-37	05725	7-3
05265	9-36, 9-37	05726	7-3
05266	9-36, 9-37	05728	6-3
05272	6-5, 6-7, 7-5, 7-7, 8-5	05729	6-3
05276	6-5, 7-5	05730	6-3
05280	6-33, 7-33	05735	6-15, 7-15, 8-11
05282	6-37, 7-37	05793	6-15, 7-15
05283	6-39, 7-39, 8-31	05795	9-13
05284	6-5, 6-7, 6-39, 7-5, 7-7, 7-39, 8-5, 8-31	06103	6-13, 7-13
05285	6-5, 6-7	06108	6-13, 7-13, 8-9
05290	6-37, 7-37	06126	6-34, 7-34
05291	6-37, 7-37	06137	6-21, 7-21, 8-17
05292	6-15	06146	6-23, 7-23, 8-19
05294	6-25, 7-25, 8-21	06174	6-23, 7-23
05297	9-31	06208	6-31, 7-31, 8-25
05390	9-31	06211	9-19, 9-21
05396	9-31	06213	9-19, 9-21
05409	9-31	06419	6-37, 7-37
05470	9-31	08169	6-19, 7-19, 8-15

CROSS REFERENCE

Part Number	Page Number	Part Number	Page Number
08182	9-19, 9-21	11467	9-4
08875	9-7, 9-8, 9-33, 9-35	11480	9-12
09005	9-31	11484	6-2, 6-41
09162	9-15, 9-17	11485	7-2, 7-41
10138	9-44	11489	6-13, 7-13
10140	9-45	11531	8-19
10155	6-29, 7-29, 8-23	11541	6-44, 7-44, 8-33
10632	6-27, 6-29, 7-27, 7-29, 8-23	11568	9-45
10632-14	6-15, 7-15, 8-11	11578	9-23, 9-25, 9-27
10632-19	6-34, 7-34, 8-28	11580	9-19, 9-21
10911	6-23, 7-23, 8-19	11581	9-28
10912	8-19, 10-3, 10-5	11608	6-33, 7-33, 8-27
10914	6-23, 7-23, 10-3	11610	9-33, 9-35
10916	9-23, 9-25, 9-27, 10-8	11612	6-13, 7-13, 8-9
10917	10-9	11613	6-13, 7-13, 8-9
10923	10-9	11636	9-7, 9-8, 9-9, 9-33, 9-35
10924	10-9	11643	9-2
10925	10-3, 10-5	11644	9-4
10926	10-3, 10-5	11647	9-2, 9-4
10927	6-13, 7-13, 8-9	11648	9-2, 9-4
10928	6-13, 7-13, 8-9	11651	6-33, 7-33, 9-33, 9-35
10929	6-8	11662	6-44
10930	6-8	11664	7-44
10931	6-8	11667	9-11
10932	7-8	11676	6-39, 7-39
10933	7-8	11679	6-37, 7-37
10934	7-8	11681	6-3
10935	6-23, 7-23, 9-23, 9-25	11682	7-3
10936	6-23, 7-23	11707	6-34
10962	6-35, 7-35, 8-29	11708	6-34, 7-34, 8-28
10967	6-35, 7-35, 8-29	11744	6-33, 7-33, 8-27
10969	9-40, 9-41	11746	6-21, 7-21, 8-17
10970	9-19, 9-21	11747	9-15, 9-17
10973	6-34, 7-34, 8-28	11750	6-21, 7-21, 8-17
10976	9-19, 9-21	11751	10-7
10982	9-19, 9-21	11752	10-7
10983	9-19, 9-21	11756	10-3
10985	9-12, 9-13	11757	10-6
10987	6-5, 7-5	11771	8-3
10988	6-5, 7-5	11772	8-3
11088	6-19, 7-19, 8-15	11773	8-3
11109	6-17, 7-17, 8-13	11776	8-3
11117	6-19, 7-19, 8-15	11777	8-3
11149	9-19	11778	8-3
11213	9-15, 9-17	11780	8-3
11214	9-15, 9-17	11781	8-3
11218	6-3, 7-3, 8-3	12083	6-25, 7-25, 8-21
11229	6-27, 6-29, 7-27, 7-29, 8-23	12694	9-49
11230	6-27, 7-27	14838	6-3, 7-3, 8-3
11235	9-19	14841	6-16, 7-16, 8-12
11236	9-15	15539	6-3, 7-3, 8-3
11238	9-15	15840	6-34, 7-34, 8-28
11239	9-15	15877	6-19, 7-19, 8-15
11241	9-15	18626	10-6
11242	9-19	18628	10-3
11243	9-19	18630	10-3
11283	6-2, 6-41, 7-2, 7-41, 8-2, 8-32	18631	10-3
		18632	10-3
		19676	6-21, 7-21, 8-17
		19783	6-3, 7-3, 8-3

CROSS REFERENCE

Part Number	Page Number	Part Number	Page Number
19800	9-53	27957	6-31, 7-31, 8-25
222396	6-21, 7-21, 8-17	27958	6-43, 7-43
22297	6-21, 7-21, 8-17	27960	6-34, 7-34, 8-28
22892	9-38, 9-39, 9-42, 9-43	27961	6-34, 7-34, 8-28
23514-1	6-37, 7-37	27962	6-34, 7-34, 8-28
24299	6-3, 7-3, 8-3	27967	6-35, 7-35
24547	6-19, 7-19, 8-15	27969	8-29
24548	6-19, 7-19	27972	6-31, 7-31
24549	6-19, 7-19	27973	6-31, 7-31, 8-25
24555	6-19, 7-19, 8-15	27974	6-31, 7-31, 8-25
24578	8-12	28009	9-36, 9-37
24589	6-41	28163	7-8, 7-9, 8-7
24633	7-41	28238	6-13, 7-13
24638	6-21, 7-21, 8-17	28272	6-19, 7-19, 8-15
24645	9-31	28286	6-29, 7-29, 8-23
24663	6-21, 7-21, 8-17	28332	6-29, 7-29
24679	8-9	28333	6-29, 7-29, 8-23
24684	6-19, 7-19, 8-15	28334	6-29, 7-29, 8-23
24686	6-2, 6-41	28335	6-29, 7-29, 8-23
24687	7-2, 7-41	28336	8-35
24760	8-9	28341	6-34, 7-34, 8-28
24785	8-9	28346	6-23, 7-23, 8-19, 9-23, 9-25, 9-27
24796	8-9	28347	6-43, 7-43, 8-35
24798	9-5, 9-6	28350	6-43, 7-43
24801	9-3	28356	9-7, 9-8, 9-33, 9-35
24836	9-3	28357	9-7, 9-8, 9-33, 9-35
24837	9-5, 9-6	28360	6-13, 7-13
24843	6-29, 7-29, 8-23, 9-44, 9-45	28365	6-13, 7-13
24852	6-13, 7-13, 8-9	28366	6-13, 7-13
24853	9-33, 9-35	28386	8-19, 10-5
24863	6-8	28396	8-29
24865	7-8	28398	8-29
24881	9-36, 9-37, 9-40, 9-41	28400	8-19
24919	8-32	28405	8-19
24926	8-31	28410	8-19
24931	7-9, 8-7	28412	8-19
24932	7-9, 8-7	28413	8-19
24942	9-3, 9-5, 9-6	28414	8-19
26315	9-15, 9-17	28415	8-9
26395-1	6-35, 7-35, 8-29	28416	6-33, 7-33, 8-27
26395-2	9-19, 9-21	28426	6-35, 7-35
26565	6-25, 7-25	28428	6-33, 7-33, 8-27
27880	6-25, 7-25, 8-21, 9-31	28429	6-33, 7-33, 8-27
27914	6-34, 7-34, 8-28	28434	8-11
27915	6-34, 7-34, 8-28	28465	8-9
27920	6-35, 7-35, 8-29	28470	8-9
27921	6-15, 7-15, 8-11	28489	8-9
27928	6-34, 7-34, 8-28	28491	8-9
27929	6-8, 7-8	28493	8-9
27934	6-31, 7-31, 8-25	28494	6-13
27937	6-31, 7-31, 8-25	28495	7-13
27941	6-34, 7-34, 8-28	28496	6-13
27945	6-34, 7-34, 8-28	28497	7-13
27947	6-34, 7-34, 8-28	28498	8-9
27948	6-34, 7-34, 8-28	28501	8-32
27950	6-34, 7-34	28542	8-9
27951	6-34, 7-34, 8-28	28545	8-9
27952	6-41, 7-41	28577	6-15, 7-15, 8-11
27953	9-25, 9-27	28583	9-9

CROSS REFERENCE

Part Number	Page Number	Part Number	Page Number
28584	9-9	33530	9-7, 9-8, 9-33, 9-35
28608	6-15, 7-15, 8-11	33531	9-7, 9-8, 9-33, 9-35
28609	6-15, 7-15	33532	6-13
28610	6-43, 7-43, 8-35	33533	6-13
28611	6-43, 7-43	33535	6-13
30058	9-40, 9-41, 9-42, 9-43	33536	6-7, 7-7, 8-5
30059	9-40, 9-42	33537	6-7, 7-7, 8-5
30215	6-3	33544	7-13
30216	7-3	33546	7-13
30240	6-3	33548	6-9
30241	7-3	33553	7-13
31203	6-33, 7-33, 8-27	33566	7-13
31204	6-33, 7-33, 8-27, 9-33, 9-35	33583	6-9
31988	6-33, 7-33, 8-27	33584	6-23, 7-23, 8-19, 9-23, 9-25, 9-27
32324	10-5	33588	8-2, 8-32
33344	6-21, 7-21, 8-17	33590	8-2, 8-32
33348	6-39, 7-39, 8-31	33671	6-27, 6-29, 7-27, 7-29, 8-23
33352	6-2, 6-41	35921	9-31
33354	7-2, 7-41	36190	6-19, 7-19, 8-15
33355	6-39, 7-39, 8-31	36758	6-13, 7-13, 8-9
33357	6-2, 6-41	37637	10-6
33360	6-5, 6-7, 7-5, 7-7, 8-5	37638	10-6
33362	6-39, 7-39, 8-31	37909	10-3
33369	7-41, 8-32	37923	10-3
33369	6-41	37925	10-5
33371	6-39, 7-39, 8-31	37926	10-3
33373	6-39, 7-39, 8-31	37929	10-3
33376	6-41, 7-41	37939	10-5
33377	6-41, 7-41	38303	10-5
33378	6-41, 7-41	38327	10-5
33379	6-39, 7-39, 8-31	38362	10-5
33388	6-39, 7-39, 8-31	38378	10-6
33391	6-39, 7-39, 8-31	38438	10-5
33395	6-39, 7-39, 8-31	38889	9-42, 9-43
33403	6-41, 7-41, 8-32	39273	9-19, 9-21
33407	6-7, 7-7, 8-5	40282	6-34, 7-34, 8-28
33408	6-33, 7-33	40670	9-54
33416	7-9, 8-7	40671	9-54
33419	7-9, 8-7	40847-1	6-39, 7-39, 8-31
33422	6-19, 7-19, 8-15	41304	9-23, 9-25, 9-27
33424	7-2, 7-41	41702	6-35, 7-35, 8-29
33427	6-13, 7-13, 8-9	43516A	6-21, 7-21, 8-17
33437	6-2, 6-41, 7-2, 7-41	43611	6-25, 7-25, 8-21
33438	6-25, 7-25, 8-21	44961	9-15, 9-17
33439	6-25, 7-25, 8-21	45261	6-15, 7-15, 8-11
33441	6-25, 7-25	45418A	10-5
33444	9-33, 9-35	45419	10-5
33446	6-19, 7-19, 8-15	45420A	10-5
33454	6-7, 7-7, 8-5	45421	10-5
33470	6-33, 7-33, 8-27	45422A	10-5
33475	8-2, 8-32	45423	10-5
33477	6-13	45424A	10-5
33484	6-19, 7-19	45960	6-15, 7-15, 8-11
33490	6-9	45962	6-29, 7-29, 8-23
33492	6-33, 7-33, 8-27	46236	6-11, 7-11
33497	9-7, 9-8, 9-33, 9-35	47277	6-19, 7-19, 8-15
33498	6-39, 7-39, 8-31	48635	9-15, 9-17
33499	6-39, 7-39, 8-31	48636	9-15, 9-17
33515	6-9		

CROSS REFERENCE

Part Number	Page Number	Part Number	Page Number
48679	6-39, 7-39, 8-31	60095	8-23
49266	6-15, 6-23, 6-31, 7-15, 7-23, 7-31, 8-11, 8-19, 8-25, 9-23, 9-25, 9-27, 9-33, 9-35, 9-53	60096	8-23
49708	6-41, 7-41, 8-32	60098	8-23
49811	9-40, 9-42	60164	8-21
49886	10-8	60165	8-21
49901	10-8	60171	8-19
50682	6-15, 7-15, 8-11	61211	9-53
51534	6-15, 7-15, 8-11	61212	9-54
54333	6-15, 6-25, 7-15, 7-25, 8-21, 9-23, 9-25, 9-27, 9-53	61214	9-53
55094	6-41, 7-41, 8-32	61297	10-3
55248	6-31, 7-31, 8-25	61415	6-19, 7-19, 8-15
56119	6-21, 6-23, 7-21, 7-23, 8-17, 8-19	61596	6-17, 7-17, 8-13
56390	6-34, 7-34	61597	6-17, 7-17, 8-13
56799	6-33, 7-33, 8-27	61598	9-29
57164	6-35, 7-35	61837	9-40, 9-41
57167	8-29	63030-2	6-35, 7-35, 8-29
57497	9-15, 9-17	63185	6-15, 7-15, 8-11
57751	6-35, 7-35, 8-29	63212	6-37, 7-37
57772	6-33, 7-33, 8-27	63244-1	6-25, 7-25, 8-21
578061	9-51	63244-3	6-25, 7-25, 8-21, 9-23, 9-25, 9-27
578063	9-51	63245-1	6-25, 7-25, 8-21, 9-53
578064	9-51	63248-1	7-3
578066	9-51	63248-2	7-3
57807	9-53	63248-3	7-3
578071	9-49	63248-4	7-3
578072	9-49	63282	6-39, 7-39, 8-31
578073	9-51	63288	9-54
578074	9-51	63342	6-25, 7-25, 8-21
578077	9-51	63740	6-29, 7-29, 8-23
578078	9-51	63755	6-27, 7-27, 9-44, 9-45
578091	9-51	63757	6-27, 7-27, 9-44, 9-45
578094	9-51	63846	6-31, 7-31, 8-25
578123	9-51	63878	6-37, 7-37
578124	9-51	64377	6-39, 7-39, 8-31
578125	9-51	64489	6-39, 7-39, 8-31
578126	9-51	64743	9-23, 9-25, 9-27
578143	9-51	64778	9-23, 9-25, 9-27
578154	9-51	65340	9-51
578155	9-51	65341	9-49
578160	9-49	65342	9-53
578161	9-51	65551	6-21, 7-21, 8-17
578164	9-51	65552	6-21, 7-21, 8-17
578214	9-51	65557	9-53
578228	9-51	65565	6-33, 7-33, 8-27
578276	9-49	65566	6-21, 7-21, 8-17
57828	6-21, 7-21, 8-17	65568	9-42, 9-43
578318	9-49	65570	9-40
578439	9-51	65571	9-42
578820	9-49	65572	9-41
578821	9-51	65573	9-43
579112	9-51	65580	9-11, 9-54
579148	9-51	65581	9-53
579198	9-51	65582	9-49
59633	6-13, 7-13, 8-9	65584	6-33, 7-33, 8-27
		65586	9-53
		65587	9-53
		65588	9-53
		65590	9-53, 10-9
		65591	9-53

CROSS REFERENCE

Part Number	Page Number	Part Number	Page Number
65592	9-53	65959	9-41, 9-43
65597	6-33	67004	6-21, 7-21
65598	7-33, 8-27	69784	6-21, 7-21, 8-17, 9-23, 9-25, 9-27
65599	9-54	75118	9-54
65607	9-53	75611	6-21, 7-21, 8-17
65608	8-33	75968	9-19, 9-21
65613	9-42, 9-43	75977	9-19, 9-21
65614	9-43	76062	6-35, 7-35, 8-29
65616	9-43	76426	6-21, 6-23, 7-21, 7-23, 8-17, 8-19
65618	9-43	76979	9-15, 9-17
65619	9-42, 9-43	78122	9-53
65620	9-41, 9-43	78544	6-2, 6-41
65621	9-40	78545	6-2, 6-41
65626	9-40, 9-42	78546	7-2, 7-41
65628	9-42	78547	7-2, 7-41
65629	9-40, 9-42	78548	8-2, 8-32
65630	9-42	78549	8-2, 8-32
65632	9-41	78550	9-41
65634	9-41	78551	6-23, 7-23, 8-19
65638	9-40	82226	6-31, 7-31, 8-25
65664	6-33, 7-33, 8-27	82457	9-9
65665	6-33, 7-33, 8-27	82962	6-39, 7-39, 8-31
65667	10-8, 10-9	86730	6-31, 7-31, 8-25
65668	10-8, 10-9	86791	6-13, 7-13, 8-9
65669	10-9	86800	6-13, 6-39, 7-13, 7-39, 8-9, 8-31, 9-19, 9-21
65670	10-9	86866	9-15, 9-17
65671	10-9	86877	6-44, 7-44, 8-33
65672	10-9	87028	9-39
65673	10-9	87284	6-33, 7-33, 9-33, 9-35
65674	10-9	87834	9-38
65675	10-8, 10-9	87977	9-53
65676	10-9	87994	9-38, 9-39
65677	10-9	87995	9-38, 9-39
65678	10-9	87996	9-38, 9-39
65683	6-23, 7-23, 8-19, 9-23, 9-25, 9-27	87997	9-38, 9-39
65684	8-32	87998	9-39
65690	6-8, 6-9, 7-8, 7-9, 8-7	87999	9-38
65695	6-21, 7-21, 8-17	89046	6-3
65697	6-43, 7-43, 8-35	89047	6-3
65698	9-23, 9-25, 9-27	89048	6-3
65700	10-8	89049	6-3
65701	10-8		
65702	10-8		
65703	10-8		
65705	10-8		
65706	10-8		
65707	10-8		
65708	10-8		
65709	10-8		
65710	10-8		
65713	9-23, 9-25, 9-27		
65717	9-23, 9-25, 9-27		
65724	9-41		
65742	6-27, 6-29, 6-34, 7-27, 7-29, 7-34, 8-28		
65744	6-29, 7-29		
65745	8-23		
65954	9-40, 9-41		
65958	9-41		

Fold along dotted lines

Tape here



NO POSTAGE
NECESSARY
IF MAILED
IN THE
UNITED STATES

BUSINESS REPLY MAIL

FIRST CLASS MAIL PERMIT NO. 94 MINNEAPOLIS, MN

POSTAGE WILL BE PAID BY ADDRESSEE

TENNANT COMPANY

Technical Publications #15
701 North Lilac Drive
P.O. Box 1452
Minneapolis, MN 55440-9947



Fold along dotted lines

Tape here



NO POSTAGE
NECESSARY
IF MAILED
IN THE
UNITED STATES

BUSINESS REPLY MAIL
FIRST CLASS MAIL PERMIT NO. 94 MINNEAPOLIS, MN

POSTAGE WILL BE PAID BY ADDRESSEE

TENNANT COMPANY

Technical Publications #15
701 North Lilac Drive
P.O. Box 1452
Minneapolis, MN 55440-9947



TENNANT COMPANY SERVICE LITERATURE AVAILABLE...

A variety of information is available to you in forms to suit your needs. The following is a list of those publications that relate to the Model 1465, 1480, and 1490 family of machines:

Machine Model	Publication	Form	TENNANT® Part No.
1465/1480/1490	Operation, Maintenance, and Parts Manual	Printed	MM185
1465/1480/1490	Operation, Maintenance, and Parts Manual	Microfiche	85185
1465/1480/1490	Operator Handbook, English, French, Spanish, German	Printed	MM186

Keep your manuals in a safe, convenient location for your future reference in order to operate, maintain, and order repair parts for your machine. Everyone who operates, maintains, or purchases parts for the machine should have easy access to a copy of the manual.

To get pricing information or to order copies of these publications, contact your nearest Tennant Company parts warehouse, distributor, or sales representative.