



Electronic Service Manuals

This electronic document is provided as a service to our customers. We do not create the contents of the information contained in this document. Should you have detailed questions pertaining to the information contained in this document, you may contact Michco, or the manufacturer which provided the original information in this electronic deliverable. Michco's only part in this electronic deliverable was the electronic assembly process. By providing this manual on line we are not guaranteeing parts availability.

You may contact Michco through the following methods:

Phone (517) 484-9312 or (800) 331-3339

2011 N. High St. -- Lansing, Michigan -- 48906

Fax: (517) 484-9836

Email: CustServe@Michco.com

Web site: www.Michco.Com

Parts Web site: www.FloorMachineParts.Com

Order Parts on Line at:

www.FloorMachineParts.Com

Directly to Parts & Service:

By Email: **Shop@Michco.com**

By Fax: (517) 702-2041

By Voice: Use numbers above.

Serving the Cleaning Industry Since 1922

Notice: All copyrighted material remains property of original owners, all trademarks are property of respective owners. Manuals are subject to Manufacturer's reproduction limitations. Originals or reproductions were provided by manufacturers through a request. We make no warranty as to the correctness of information provided in this document and you assume all risk. By placing these manuals on line we are not declaring our corporation to be an manufacturer authorized dealer or provider, please check our web site for authorized manufacturers we represent.

OWNER'S GUIDE

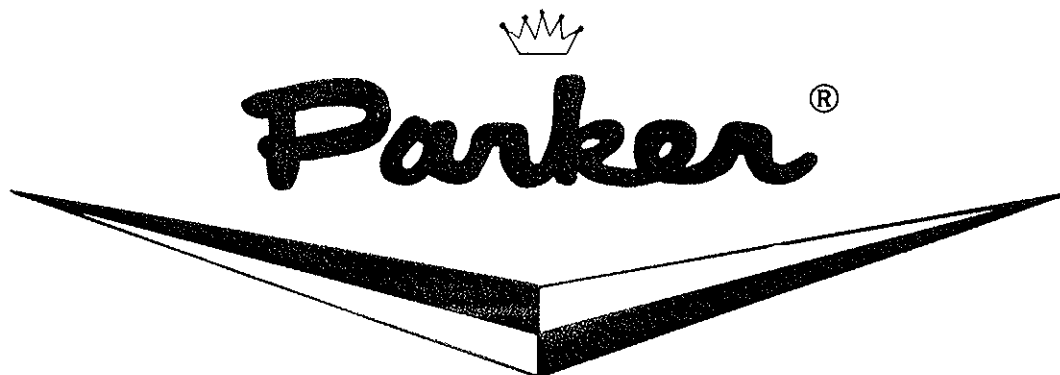

SV-8930-Q SCAVENGER®

30" VACUUM SWEEPER

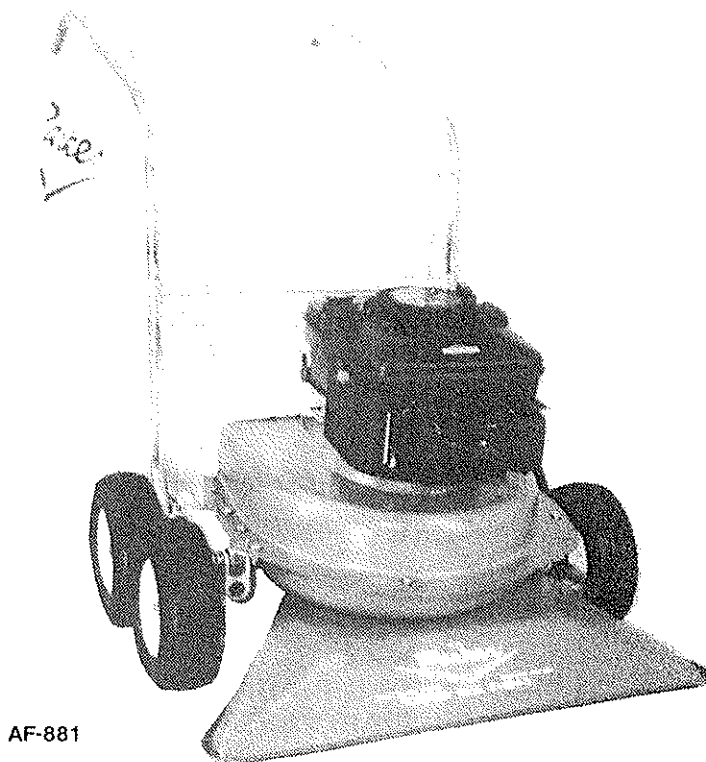

AF-881

**READ THESE INSTRUCTIONS
BEFORE SETTING UP AND OPERATING MACHINE**

**BE SAFE. PROTECT YOUR FAMILY, YOUR FRIENDS, YOURSELF.
OBSERVE ALL SAFETY INSTRUCTIONS.**

PARKER SWEEPER COMPANY

Box 1728

Springfield, Ohio 45501-1728

Plate No. 1460

89-111-A

TO THE OWNER

These instructions were written to assist you in the assembly and operation of your Scavenger. **READ THE INSTRUCTIONS** thoroughly **BEFORE** attempting to assemble and operate the machine so that you are familiar with the complete procedure and the safety precautions.

RULES FOR SAFE OPERATION



The following safety precautions are suggested to prevent damage to the equipment or injury to the operator or nearby persons.

1. Do not allow anyone to operate the Scavenger without proper instructions.
2. Do not permit children to operate the Scavenger.
3. Do not sweep too close to fire. Ingesting hot ashes will ignite the bag.
4. Stop the engine before reaching into the intake nozzle or discharge chute to dislodge sticks or other debris.
5. Stop the Engine before attempting to make any adjustment or performing any maintenance work on the Scavenger.
6. When working on the engine, always remove the spark plug wire from the engine and attach it to the V shaped clip on the engine head.
7. Do not run the engine in an enclosed area. Exhaust gases contain carbon monoxide, an odorless and deadly poison.
8. Do not fill the fuel tank while the engine is running. Spilling gasoline on a hot engine may cause a fire or an explosion.
9. While machine is running, do not leave it unattended.
10. Before using the machine to pick up debris, police the area to be cleaned first, picking up any large objects such as cans, toys, dog bones and chunks of wood. If these pass through the machine, they could damage the impeller, bend the engine crankshaft or put a hole in the bag.
11. Avoid using the machine in dangerous places where steep slopes or loose debris will endanger the safety of the operator or other people.
12. Keep all nuts, bolts and screws tight to be sure the Scavenger is in safe working condition.
13. Follow the maintenance instructions as outlined in this manual.
14. Do not start or run engine unless bag is properly secured as injury may result.

IMPORTANT

ALWAYS GIVE THE FOLLOWING INFORMATION WHEN ORDERING REPAIR PARTS:

- | | |
|-------------------------------|---------------------------|
| 1. Part Number (Not Ref. No.) | 3. Description of Part |
| 2. Quantity Needed | 4. Model No. of Scavenger |

If unable to obtain parts locally, write down above information and send to:
PARKER SWEEPER CO., BOX 1728, SPRINGFIELD, OHIO 45501

Your unit is right hand (R.H.) or left hand (L.H.) as you stand behind it.

HANDLE AND BAG ASSEMBLY

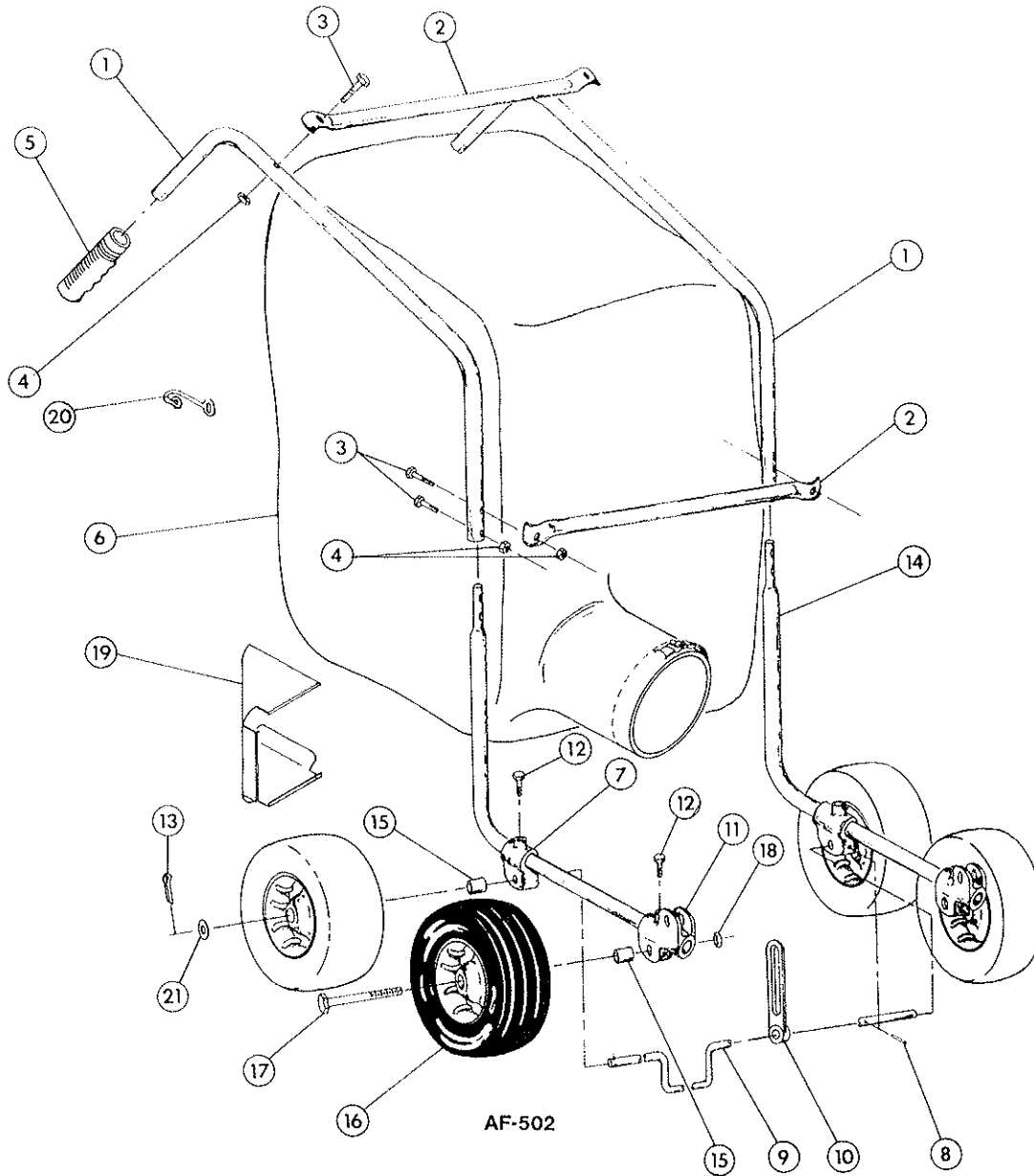

PARTS LIST

Item No.	Part No.	Unit Qty.	Description	Item No.	Part No.	Unit Qty.	Description
1	84-61-C	2	Handle, Upper	11	84-53-B	2	Pivot
2	84-60-B	2	Cross Bar	12	72-616-32	4	Bolt, Hex Hd. 3/8-16 x 8
3	65-416-24	6	Bolt, Hex Hd. 1/4-20 x 1 1/2	13	380-632-20	2	Pin, Cotter
4	365-416	6	Nut, Hex Lock 1/4-20	14	84-56-C	2	Handle, Lower
5	84-120-A	2	Grip, Handle	15	84-136-A	4	Spacer
6	MA-535	1	Bag Assembly	16	84-137-C	4	Wheel
7	84-50-B	2	Support	17	60-816-84	2	Bolt, Hex Hd. 1/2-20 x 5 1/4
8	84-103-A	2	Pin, Roll .1965 Diameter x 1 1/2	18	367-816	2	Nut, Lock Jam 1/2-20
9	84-49-C	1	Axle	19	82-194-C	1	Deflector Assembly
10	84-236-B	1	Height Adjustment	20	63-304-A	4	Hook, Bag (Included in Bag)
				21	945-1016	As Req'd.	Flatwasher, Plain 5/8

CHASSIS ASSEMBLY

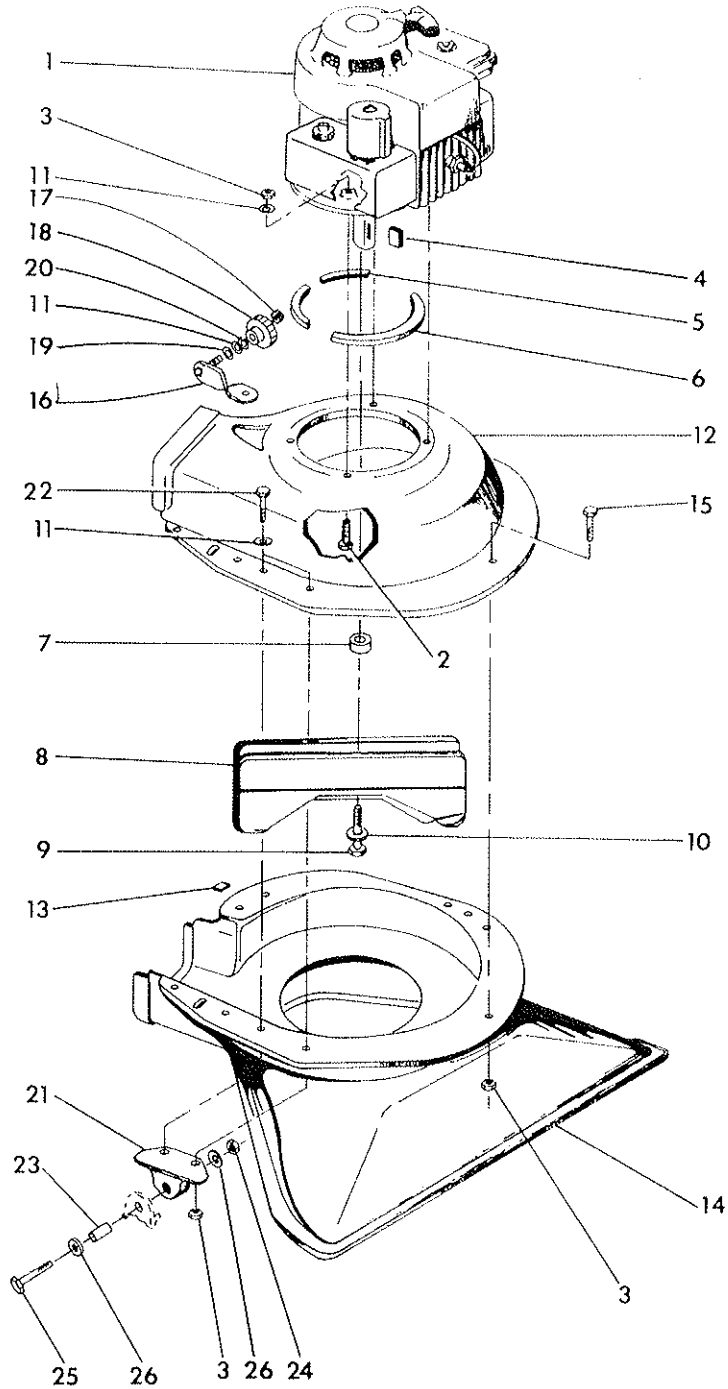

AF-501

CHASSIS ASSEMBLY**PARTS LIST**

Item No.	Part No.	Unit Qty.	Description
1	*	1	Engine, 5 HP Briggs and Stratton
2	65-516-24	3	Bolt, Hex Hd. 5/16-18 x 1 1/2
3	365-516	13	Nut, Hex Lock 5/16-18
4	48-277-A	1	Key, Engine
5	64-178-A6	2	Shim, Rubber
6	64-178-A9.5	1	Shim, Rubber
7	89-113-A	1	Spacer
8	SA-1014-B	1	Impeller Subassembly
9	60-616-32	1	Bolt, Hex Hd. 3/8-24 x 2
10	935-616	1	Lockwasher, Spring 3/8
11	945-516	8	Flatwasher, Plain 5/16
12	82-04-C	1	Housing, Upper Blower
13	64-178-A-1	1	Shim, Rubber
14	89-110-D	1	Housing, Nozzle and Blower
15	65-516-10	5	Bolt, Hex Hd. 5/16-18 x 5/8
16	84-238-A	1	Adjustment Bracket Assembly
17	364-516	1	Nut, Hex Lock Thin 5/16-18
18	79-94-A	1	Knob, Plastic
19	937-516	1	Lockwasher, External Tooth 5/16
20	935-516	1	Lockwasher, Spring 5/16
21	84-54-B	2	Hinge
22	65-516-16	4	Bolt, Hex Hd. 5/16-18 x 1
23	85-37-A	2	Spacer
24	365-616	2	Nut, Hex Lock 3/8-16
25	65-616-36	2	Bolt, Hex Hd. 3/8-16 x 2 1/4
26	945-616	4	Flatwasher, Plain 3/8

*Briggs & Stratton Model No. ~~124702~~, Type & Trim ~~0157-01~~
126702 *0140-01*

ASSEMBLY INSTRUCTIONS

YOUR SAFETY IS OUR CONCERN. READ ALL SAFETY RULES AND OPERATING INSTRUCTIONS BEFORE ATTEMPTING TO OPERATE THIS EQUIPMENT. FAILURE TO FOLLOW SAFETY RULES AND OPERATING INSTRUCTIONS MAY RESULT IN SERIOUS INJURY.

NOTE: All mounting hardware is on the unit in its proper location.

1. Remove unit from box. Do not discard any inserts or packing until unit is completely assembled.
2. Assemble upper handle (1) to lower handle (14) and attach with crossbar (2), hex head bolts (3) and hex lock nuts (4).
3. Attach remaining crossbar (2) above first crossbar with hex head bolts (3) and hex lock nuts (4).
4. Slide the bag deflector over the discharge chute, as shown. Engage the strap into the buckle and tighten to retain bag deflector.

NOTE: Unit can be used as a blower by removing bag and reversing deflector.

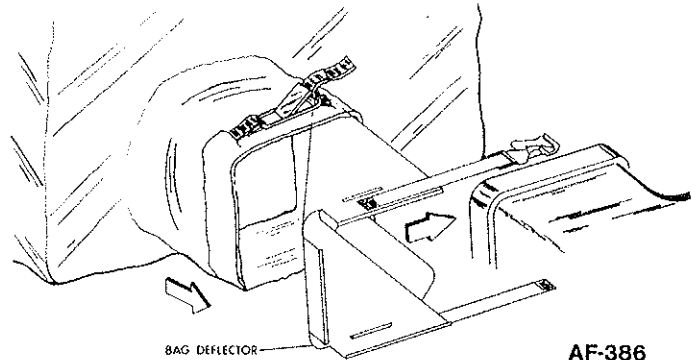

5. Slip the neck of the bag over the bag deflector and discharge housing until the tightening strap passes over the bag deflector to rest on the discharge housing. Pull the strap tight to secure the bag to the unit. Secure bag hooks to upper and lower crossbars.

OPERATING INSTRUCTIONS

READ SAFETY & OPERATING INSTRUCTIONS BEFORE OPERATING EQUIPMENT

CAUTION: The engine contains NO OIL. Read the engine instruction manual carefully before operating. Be sure you know how to start and stop engine.

1. Before starting the engine read and understand the following:
 - a. Be sure your engine crankcase is filled with the proper type and amount of oil.
 - b. Lubricate the wheel bearings and wheel axle on the caster once a week if used daily. A few drops of oil applied to the throttle control cable and wire where applicable, will keep it operating smoothly.

NOTE: Refer to engine operating instructions for proper lubrication of the engine.

HEIGHT ADJUSTMENT

2. Nozzle adjustment may be made by:
 - a. Loosen adjusting knob located at rear of housings.
 - b. Set nozzle height by moving knob up to lower nozzle or down to raise. Tighten knob to secure nozzle height.

3. Heavy concentration of sand and gravel should be avoided. These materials are extremely abrasive, and while the Scavenger will handle moderate amounts of these materials, it is not designed for heavy applications. Because these materials are extremely heavy, only small amounts should be allowed to collect in the bag because large amounts cause poor handling and difficulty in pushing. The Scavenger is capable of picking up empty tin cans and blocks of wood, but it was not intended for this type of service, since tremendous stresses build up as these pieces pass through the impeller. Treat your Scavenger with reasonable care and it will repay you with long trouble-free service.
4. The Scavenger will handle most common kinds of debris found around industrial plants, commercial buildings, homes and farms. Acid contaminated materials, magnesium, dust and other **DANGEROUS DEBRIS** that is considered hazardous should not be handled with the Scavenger unless approved by a regulating authority considered to be an expert in the handling of such hazardous materials.

DANGER: Improper use of this equipment may result in serious injury.

OBSERVE SAFETY RULES AT ALL TIMES. DON'T TAKE CHANCES!

MAINTENANCE INSTRUCTIONS

OBSERVE SAFETY RULES AT ALL TIMES. DON'T TAKE CHANCES!

CAUTION: DO NOT WORK ON SCAVENGER with engine running or idling. Bring to a **DEAD STOP**. Remove spark plug on engine.

1. For servicing and operating instructions for engine refer to Engine Manufacturers Service Manual. Careful attention to care of air cleaner and crankcase lubrication instructions will insure longer engine life. **KEEP ENGINE CLEAN.**
2. Be sure to keep the oil at the proper level in the engine. Check the oil level each time you fill the fuel tank.
3. Clean the engine air cleaner every 10 hours of operation. (Do so more often under dusty conditions.) If it is punctured, torn, or uncleanable, it should be replaced.
4. Keep the dust bag clean and dry. Clean the bag thoroughly after each use. A dirty bag will reduce the efficiency of the machine.
5. To drain the crankcase oil from the engine, we have provided a siphon pump. To use it, run the engine for a short time to warm the oil and make it flow more easily. Then remove the cap from the filler hole in the engine and insert the plastic tube into the hole. Hold the pump below the bottom of the crankcase and squeeze it several times until oil appears in the tube above the pump, and allow the oil to siphon into a container for disposal. **DISPOSE OF PROPERLY.**

6. DUST BAG CARE

- a. Keep the Dust Bag clean at all times.
 - b. To clean the Dust Bag, turn the bag inside out and reattach to the sweeper.
 - c. Start the engine and run at full throttle. Lightly tap the bag to release the dust trapped in the weave.
 - d. When the bag is clean, remove it and turn it right side out again. Reattach to the sweeper and resume sweeping.
 - e. **DO NOT** wash the Dust Bag to clean. Washing will shrink the material, reducing air flow through the bag and seriously reduce vacuum.
7. The efficiency of this unit depends on the breathing capacity of the Dust Bag. Under extremely dusty conditions the bag should be emptied and cleaned frequently. Always empty and clean bag before storing after use. Debris allowed to remain in the bag may cause spontaneous combustion, resulting in an explosion or fire.

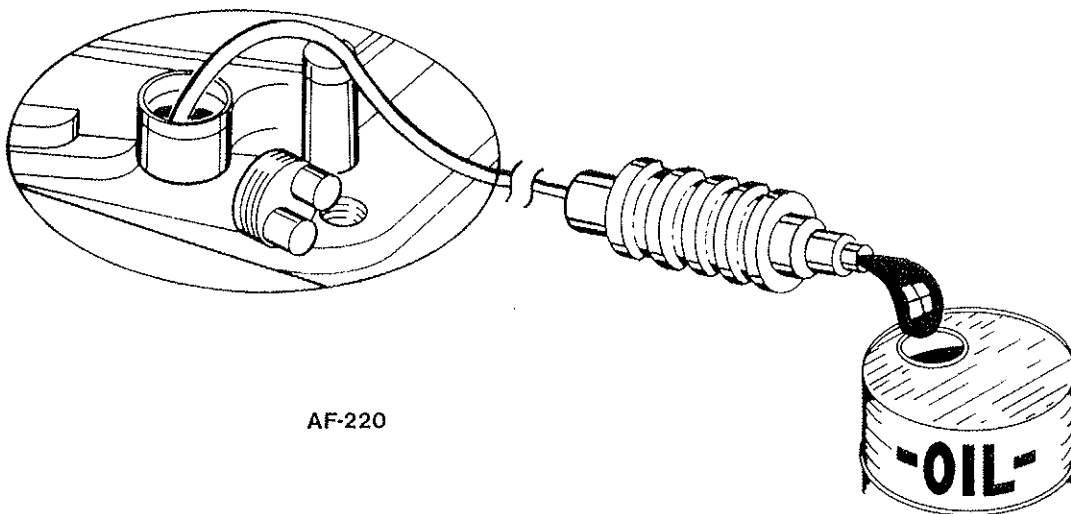

AF-220

NOTE: FAILURE TO OBSERVE SAFETY INSTRUCTIONS MAY RESULT IN SERIOUS INJURY.