



Electronic Service Manuals

This electronic document is provided as a service to our customers. We do not create the contents of the information contained in this document. Should you have detailed questions pertaining to the information contained in this document, you may contact Michco, or the manufacturer which provided the original information in this electronic deliverable. Michco's only part in this electronic deliverable was the electronic assembly process. By providing this manual on line we are not guaranteeing parts availability.

You may contact Michco through the following methods:

Phone (517) 484-9312 or (800) 331-3339

2011 N. High St. -- Lansing, Michigan -- 48906

Fax: (517) 484-9836

Email: CustServe@Michco.com

Web site: www.Michco.Com

Parts Web site: www.FloorMachineParts.Com

Order Parts on Line at:

www.FloorMachineParts.Com

Directly to Parts & Service:

By Email: **Shop@Michco.com**

By Fax: (517) 702-2041

By Voice: Use numbers above.

Serving the Cleaning Industry Since 1922

Notice: All copyrighted material remains property of original owners, all trademarks are property of respective owners. Manuals are subject to Manufacturer's reproduction limitations. Originals or reproductions were provided by manufacturers through a request. We make no warranty as to the correctness of information provided in this document and you assume all risk. By placing these manuals on line we are not declaring our corporation to be an manufacturer authorized dealer or provider, please check our web site for authorized manufacturers we represent.

OWNERS GUIDE

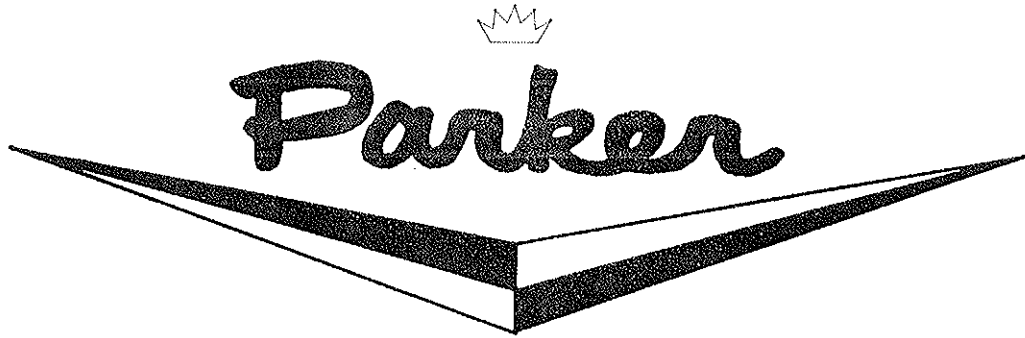

SV-7830 SCAVENGER[®]

30" VACUUM SWEEPER

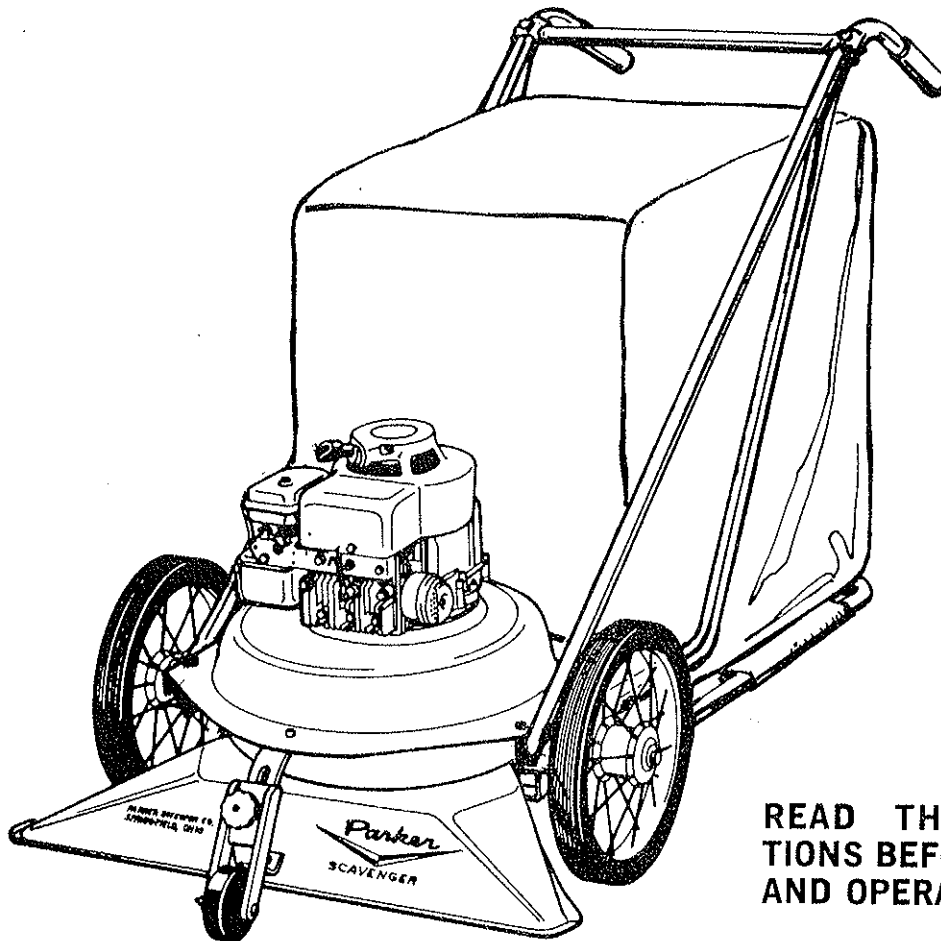

READ THESE INSTRUCTIONS BEFORE SETTING UP AND OPERATING MACHINE.

PARKER SWEEPER COMPANY

Box 1728

Springfield, Ohio 45501

Plate No. 409

Part No. 78-85

ASSEMBLY AND OPERATING INSTRUCTIONS

MODEL SV-7830

Your Scavenger, Model SV-7830, is shipped in two cartons. Empty the cartons, but do not discard any of the cartons or inserts until after the machine is completely assembled. The right or left side of the machine is determined from the operator's position at the rear of the machine.

The Handle Carton Contains
the following:

- 2-Handles
- 2-Truss Braces
- 1-Cross Brace

SAT 21

The Unit Carton Contains
the following:

- 1-Unit Assembly
- 1-Front Roller Assembly
- 1-Dust Bag Assembly
- 1-Bag Platform Frame
- 1-Bag Platform Crossbar
- 1-Bag Platform Sleeve
- 1-Siphon Pump
- 1-Roller Assembly
- 1-Hardware Bag

The Plastic hardware bag should contain the following parts:

- | | |
|------------------------------------|--|
| 2- 78-64 Handle Grip | 1- 935-516 5/16 Lockwasher |
| 1- 59-47 Knob | 2- 54-227 Spacer |
| 4- 76-178 Handle Insert | 2- 69-416-20 1/4-20x1 1/4 Contour Bolt |
| 2- 65-416-24 1/4-20x1 1/2 Bolt | 2- 335-416 1/4-20 Hexagon Nut |
| 2-365-416 1/4-20 Lock Nut | 2- 935-416 1/4 Lockwasher |
| 2- 65-516-24 5/16-18x1 1/2 Bolt | 1- 59-77 Tube Clamp |
| 2- 65-516-28 5/16-18x1 1/4 Bolt | 1- 59-68 Pivot Block |
| 5- 365-516 5/16-18 Lock Nut | 1- 65-516-32 5/16-18x2 Bolt |
| 4- 945-516 5/16 Flat Washer | 1- 960-516 Flat Washer |
| 1- 70-516-32 5/16-18 Carriage Bolt | |

You will need two 7/16" wrenches and two 1/2" wrenches to assemble this machine.

ASSEMBLY INSTRUCTIONS

Place the sweeper assembly on a work bench or table with the intake nozzle facing you. Install the front roller assembly by inserting the 5/16 x 2" carriage bolt through the slotted bracket on the front of the machine. Place the roller assembly over the bolt and bracket so that the roller is down and the roller fork straddles the bracket. Then install a 5/16" lock washer and the hand knob on the bolt. Raise the roller assembly until the top of the roller fork is even with the top of the slot in the bracket and tighten the hand knob to hold the roller in position and place the machine on the ground or floor.

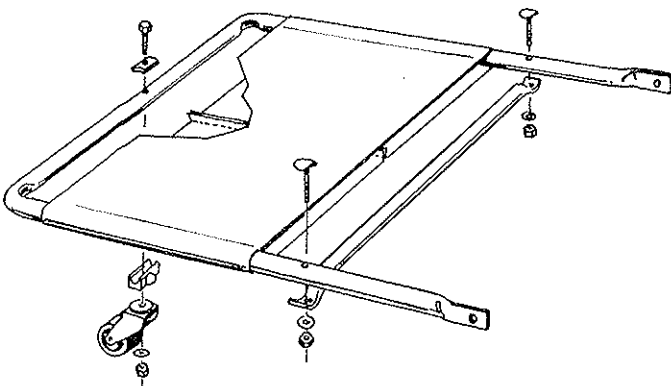
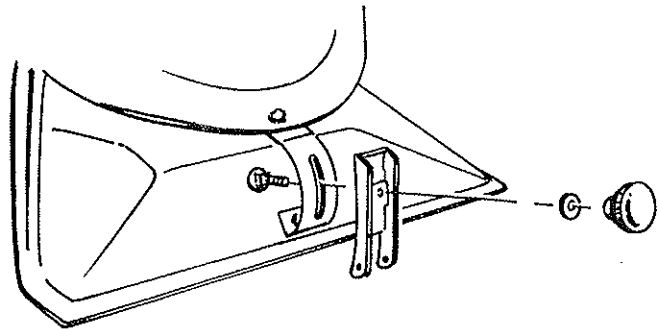

Next, using the 5/16 x 2" bolt, the tube clamp, pivot block, washer and a 5/16" lock nut, install the caster assembly to the back of the bag platform frame and tighten the bolt securely. Now slide the vinyl sleeve over the sides of the frame so that the stitched seam in the sleeve is on the bottom side of the frame. (The same side as the caster roller.) Now insert two of the 1/4" contour head bolts in the holes in the bag platform frame with the heads on the **TOP** side. Now install the platform cross bar over these two bolts from the **under** side and install and tighten the two 1/4" lock washers and nuts.

CHASSIS ASSEMBLY

Updated 5/20/94 ✓

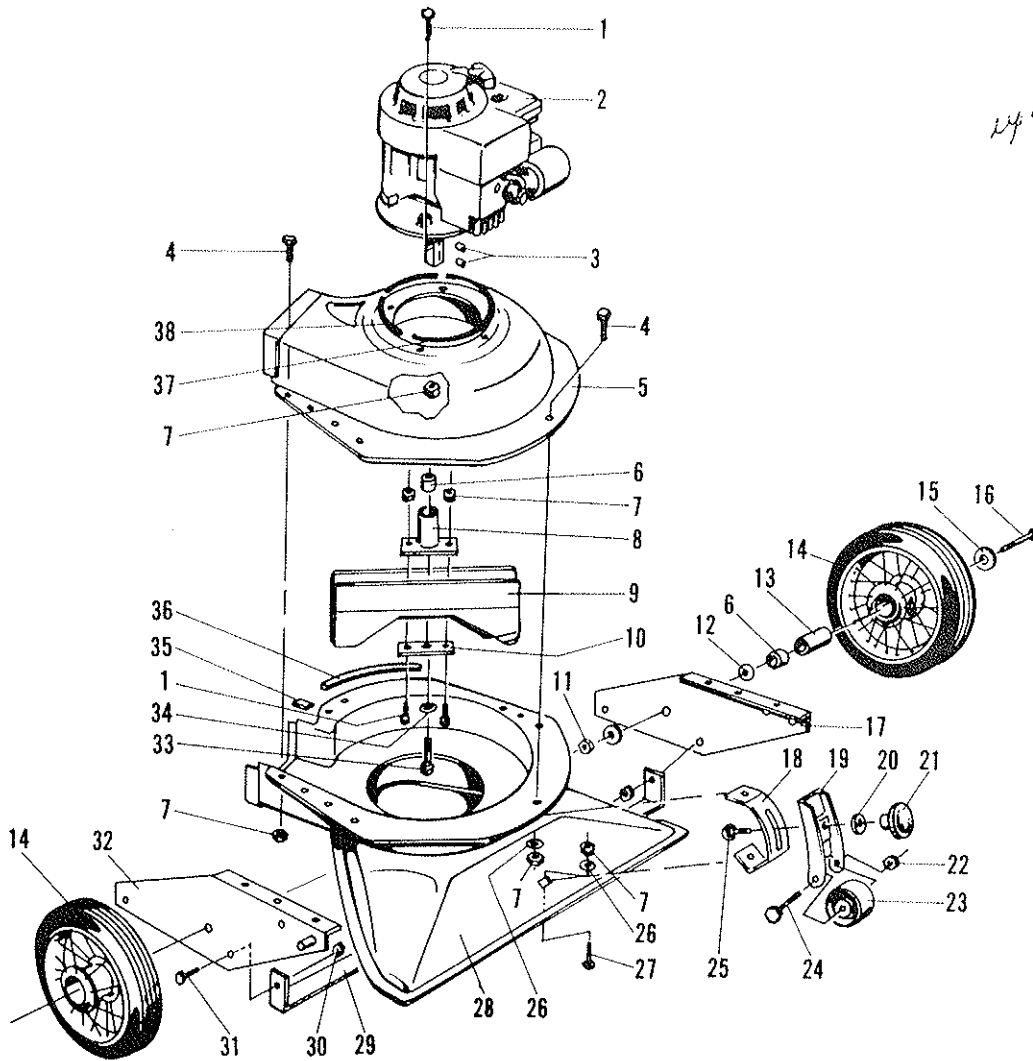

PARTS LIST

Ref. No.	Part No.	Qty. Per Unit	Description	Ref. No.	Part No.	Qty. Per Unit	Description
1	65-516-20	5	Bolt 5/16-18 x 1 1/4	20	935-516	1	5/16 Spring Lockwasher
2	65-428-A	1	Engine	21	79-94-A ✓	1	Adjusting Knob
3	64-43-A	2	#505 Hi-Pro Key	22	365-616	1	Nut 3/8-16 Hex Lock
4	65-516-12	10	Bolt 5/16-18 x 3/4 Hex Head	23	64-169-A ✓	1	Roller w/Bushing
5	63-280-F	1	Upper Housing <i>82-04-C</i>	24	65-616-48	1	Bolt 3/8-16 x 3 Hex Head
6	73-414-A	3	Spacer	25	70-516-32	1	Carriage Bolt 5/16-18 x 2
7	365-516	16	Nut 5/16-18 Hex Lock	26	945-516	2	Flat Washer 5/16
8	63-298-A	1	Fan Blade Adapter <i>81-193-A</i>	27	73-516-12	1	Step Bolt 5/16-18 x 3/4
9	63-287-B ✓	1	Fan Assembly	28	67-76-F	1	Nozzle Assembly
10	63-305-A ✓	1	Fan Anchor Plate	29	78-63-B	1	Side Plate Support
11	363-816	2	Nut 1/2-20 Hex Lock	30	365-416	3	Nut 1/4-20 Hex Lock
12	68-95-A	6	Flat Washer 1/2	31	65-416-12	3	Bolt 1/4-20 x 3/4
13	73-33-A ✓	2	Wheel Bushing	32	78-60-B	1	Side Plate R.H.
14	SA-357-C ✓	2	Wheel Assembly	33	60-616-28	1	Bolt 3/8-24 x 1 1/8 Hex Head
16	60-816-72	2	Bolt 1/2-20 x 4 Hex Head	34	935-616	1	3/8 Spring Lockwasher
	78-59-B	1	Side Plate L.H.	35	400-1	1	Rub-R-Shim 1" <i>64-178-A</i>
18	66-216-B ✓	1	Front Roller Support	36	63-299-A	1	Rubber Molding
19	64-167-B ✓	1	Roller Fork	37	400-9-1/2	1	Rub-R-Shim 9/16" <i>64-178-A-9.5</i>
				38	400-6	2	Rub-R-Shim 6" <i>64-178-A-6 ✓</i>

HANDLE & BAG ASSEMBLY

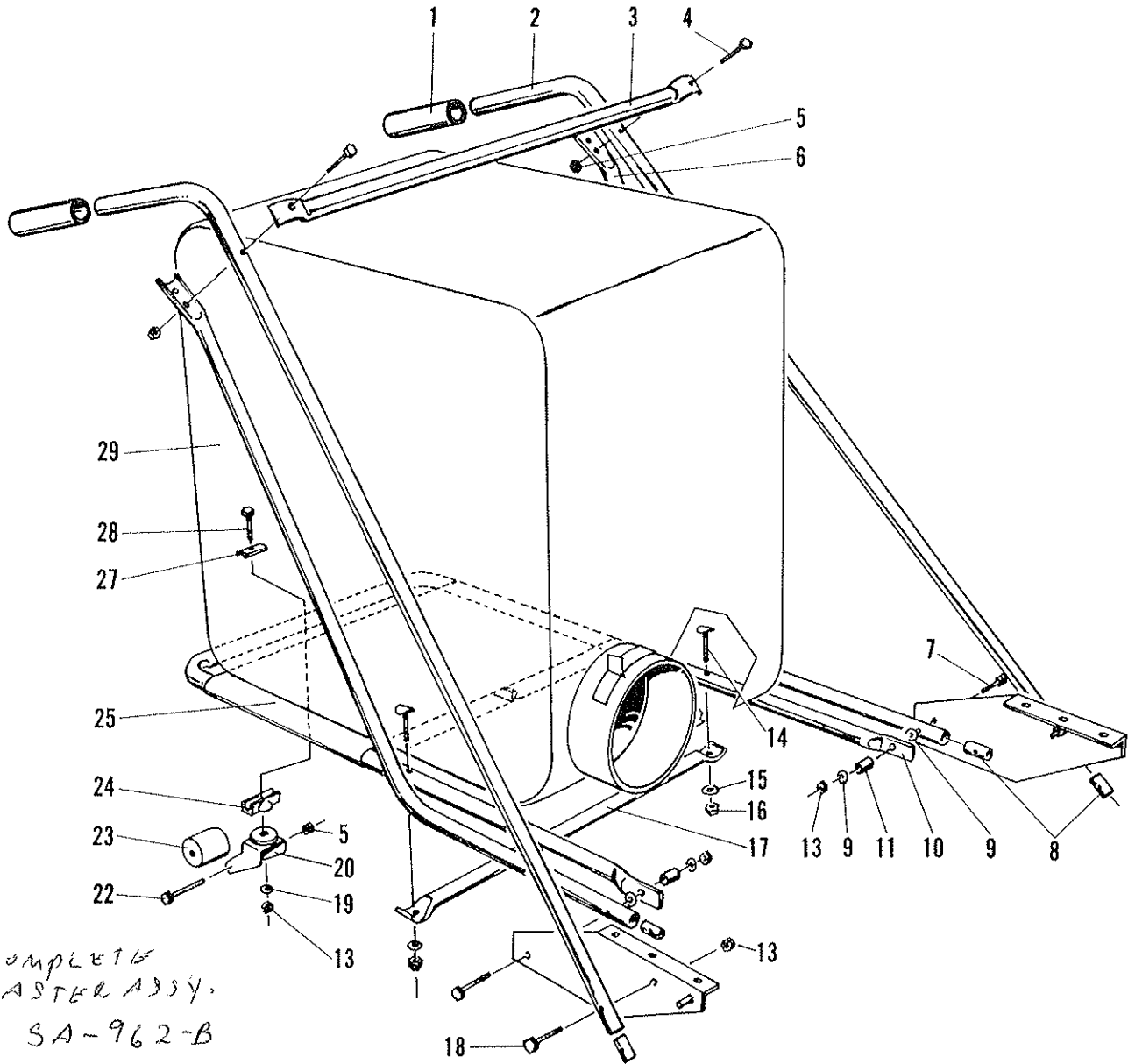

PARTS LIST

Ref. No.	Part No.	Qty. Per Unit	Description of Part	Ref. No.	Part No.	Qty. Per Unit	Description of Part
1	78-64-A	2	Handle Grip	15	935-416	2	Lockwasher 1/4 Spring
2	77-98-B	2	Handle	16	335-416	2	Nut 1/4-20 Hex Plain
3	77-105-B	1	Cross Brace	17	77-114-B	1	Cross Brace
4	65-416-24	2	Bolt 1/4-20 x 1 1/2 Hex Head	18	65-516-24	2	Bolt 5/16-18 x 1 1/2 Hex Head
5	365-416	3	Nut 1/4-20 Hex Lock	19	960-516	1	Flat Washer 5/16 SAE
6	77-99-B	2	Truss Brace	20	76-143-B	1	Caster Fork Assy.
7	65-516-28	2	Bolt 5/16-18 x 1 1/4 Hex Head	22	76-202-A	1	Axle
8	76-178-A	4	Handle Insert	23	76-58-A	1	Roller <i>81-79-A</i>
9	945-516	4	Flatwasher 5/16	24	59-68-B	1	Pivot Block <i>79-174-A</i>
10	77-113-B	1	Frame - Bag Platform	25	77-115-B	1	Platform Sleeve
11	54-227-A	2	Spacer	27	59-77-A	1	Tube Clamp
13	365-516	5	Nut 5/16-8 Hex Lock	28	65-516-32	1	Bolt 5/16-18 x 2 Hex Head
14	69-416-20	2	Bolt 1/4-20 x 1 1/4 Cont. Head	29	SA-657-C	1	Dust Bag Assy.
					<i>MA-424</i>		

Corrections on SV-7830 Scavenger Owner's Guide

On the Chassis Assembly:

Item 4 - Bolt should be 5/16-18 by 1" long instead of 3/4" long as listed.

Item 6 - Should be Spacer, #77-106^A (Quantity - 1)

Item 8 - Should be Fan Adaptor, ~~#77-103~~ (Quantity - 1)

Item 11 - Should be #368-816, Jam Nut, Locking, 1/2-20 thd.

Item 12 - Quantity of washer is now 6.

Item 16 - Should be ~~#60-816-72~~, Bolt, Hex Hd., 1/2-20 x 2 1/2.

~~60-816-56~~ or ~~60-816-80~~

Item 21 - The adjusting knob is now #79-94-A. ✓

On the Handle & Bag Assembly:

Item 19 - Should be a special washer, ~~#50-230-A~~^{82-138-B-1} (Quantity - 1).

Item 20 - Should be Fork, #76-136-B^V (Quantity - 1), and bearing, #78-130-A (Quantity - 1).

Item 29 - Should be Dust Bag Ass'y., ~~#SA-790-D~~^{MA-426}, (Quantity - 1).

^{82-194-C}
A deflector, ~~#65-421-C~~, has been added to your Scavenger to aid in better collection and storage of debris in the dust bag. Installation is as follows:

Slide the "U" shaped bracket of the bag deflector over the discharge chute. Slip the neck of the bag over the bag deflector and discharge housing until the tightening strap passes over the metal collar. Pull the strap tight and secure the bag to the unit.

An engine adaptor ring, #77-112, has been added between the upper housing (Item 5) and the engine (Item 2). Also a shaft guard, ~~#79-49~~, has also been added.

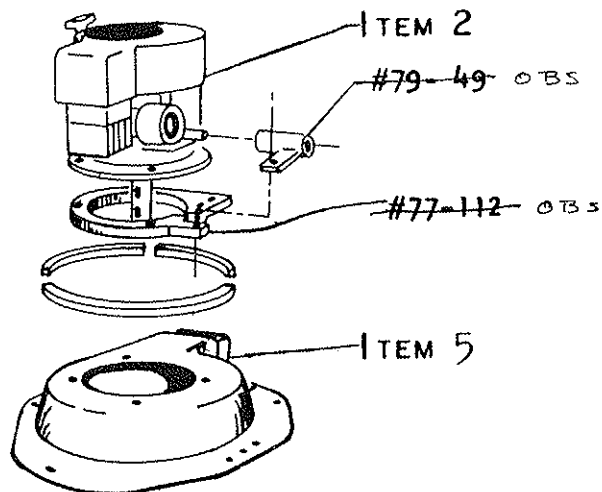
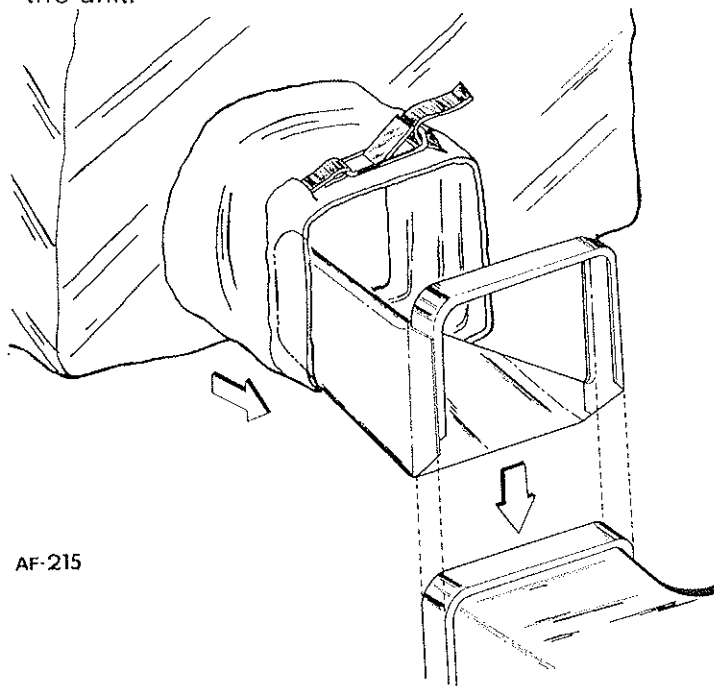

10

11

12

CHASSIS ASSEMBLY

Updated 5/20/94 ✓

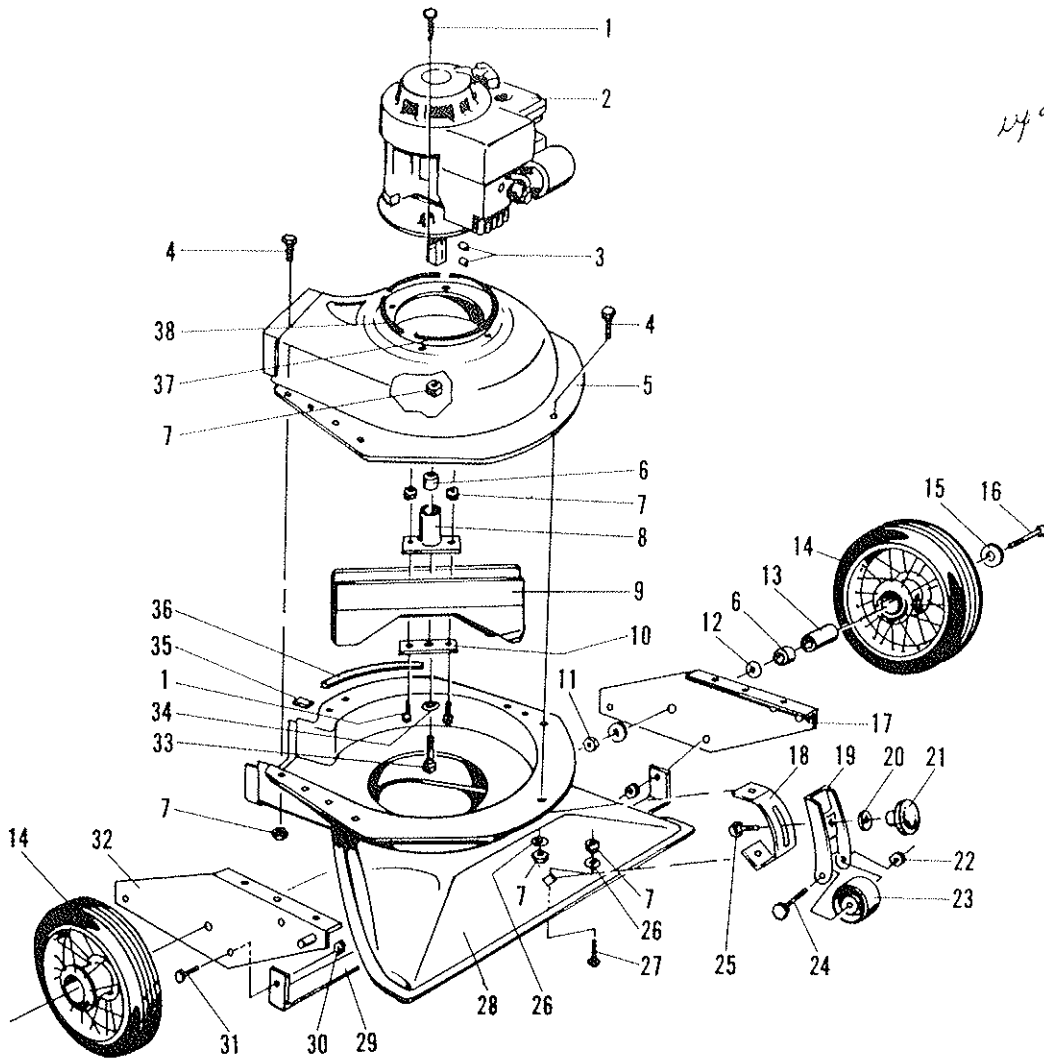

PARTS LIST

Ref. No.	Part No.	Qty. Per Unit	Description	Ref. No.	Part No.	Qty. Per Unit	Description
1	65-516-20	5	Bolt 5/16-18 x 1 1/4	20	935-516	1	5/16 Spring Lockwasher
2	65-428-A	1	Engine	21	79-94-A ✓	1	Adjusting Knob
3	64-43-A	2	#505 Hi-Pro Key	22	365-616	1	Nut 3/8-16 Hex Lock
4	65-516-12	10	Bolt 5/16-18 x 3/4 Hex Head	23	64-169-A ✓	1	Roller w/Bushing
5	63-280-F	1	Upper Housing * 82-04-C	24	65-616-48	1	Bolt 3/8-16 x 3 Hex Head
6	73-414-A	3	Spacer	25	70-516-32	1	Carriage Bolt 5/16-18 x 2
7	365-516	16	Nut 5/16-18 Hex Lock	26	945-516	2	Flat Washer 5/16
8	63-298-A	1	Fan Blade Adapter 81-195-A	27	73-516-12	1	Step Bolt 5/16-18 x 3/4
9	63-287-B ✓	1	Fan Assembly	28	67-76-F	1	Nozzle Assembly
10	63-305-A ✓	1	Fan Anchor Plate	29	78-63-B	1	Side Plate Support
11	363-816	2	Nut 1/2-20 Hex Lock	30	365-416	3	Nut 1/4-20 Hex Lock
12	68-95-A	6	Flat Washer 1/2	31	65-416-12	3	Bolt 1/4-20 x 3/4
13	73-33-A ✓	2	Wheel Bushing	32	78-60-B	1	Side Plate R.H.
14	SA-357-C ✓	2	Wheel Assembly	33	60-616-28	1	Bolt 3/8-24 x 1 1/8 Hex Head
16	60-816-72	2	Bolt 1/2-20 x 4 Hex Head	34	935-616	1	3/8 Spring Lockwasher
	78-59-B	1	Side Plate L.H.	35	400-1	1	Rub-R-Shim 1" 64-178-A'
18	66-216-B ✓	1	Front Roller Support	36	63-299-A	1	Rubber Molding
19	64-167-B ✓	1	Roller Fork	37	400-9-1/2	1	Rub-R-Shim 9/8 64-178-A-9.5
				38	400-6	2	Rub-R-Shim 6" 64-178-A-6 ✓

HANDLE & BAG ASSEMBLY

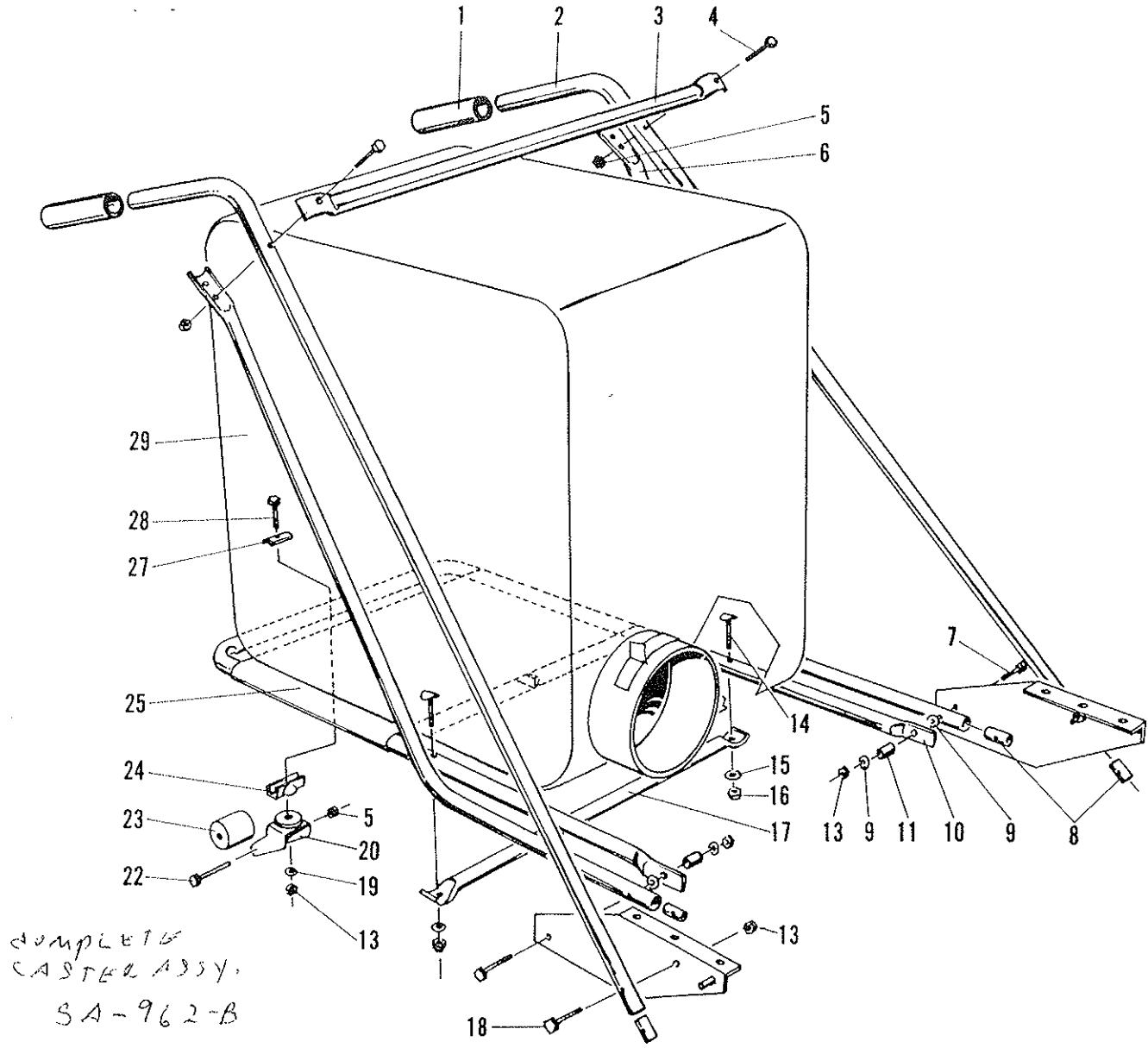

PARTS LIST

Ref. No.	Part No.	Qty. Per Unit	Description of Part	Ref. No.	Part No.	Qty. Per Unit	Description of Part
1	78-64-A	2	Handle Grip	15	935-416	2	Lockwasher 1/4 Spring
2	77-98-B	2	Handle	16	335-416	2	Nut 1/4-20 Hex Plain
3	77-105-B	1	Cross Brace	17	77-114-B	1	Cross Brace
4	65-416-24	2	Bolt 1/4-20 x 1 1/2 Hex Head	18	65-516-24	2	Bolt 5/16-18 x 1 1/2 Hex Head
5	365-416	3	Nut 1/4-20 Hex Lock	19	960-516	1	Flat Washer 5/16 SAE
6	77-99-B	2	Truss Brace	20	76-143-B	1	Caster Fork Assy.
7	65-516-28	2	Bolt 5/16-18 x 1 1/4 Hex Head	22	76-202-A	1	Axle
8	76-178-A	4	Handle Insert	23	76-58-A	1	Roller 81-79-A ✓
9	945-516	4	Flatwasher 5/16	24	59-68-B	1	Pivot Block 79-174-A
10	77-113-B	1	Frame - Bag Platform	25	77-115-B	1	Platform Sleeve
11	54-227-A	2	Spacer	27	59-77-A ✓	1	Tube Clamp
13	365-516	5	Nut 5/16-8 Hex Lock	28	65-516-32	1	Bolt 5/16-18 x 2 Hex Head
14	69-416-20	2	Bolt 1/4-20 x 1 1/4 Cont. Head	29	SA-657-C MA-426	1	Dust Bag Assy.