



Electronic Service Manuals

This electronic document is provided as a service to our customers. We do not create the contents of the information contained in this document. Should you have detailed questions pertaining to the information contained in this document, you may contact Michco, or the manufacturer which provided the original information in this electronic deliverable. Michco's only part in this electronic deliverable was the electronic assembly process. By providing this manual on line we are not guaranteeing parts availability.

You may contact Michco through the following methods:

Phone (517) 484-9312 or (800) 331-3339

2011 N. High St. -- Lansing, Michigan -- 48906

Fax: (517) 484-9836

Email: CustServe@Michco.com

Web site: www.Michco.Com

Parts Web site: www.FloorMachineParts.Com

Order Parts on Line at:

www.FloorMachineParts.Com

Directly to Parts & Service:

By Email: **Shop@Michco.com**

By Fax: (517) 702-2041

By Voice: Use numbers above.

Serving the Cleaning Industry Since 1922

Notice: All copyrighted material remains property of original owners, all trademarks are property of respective owners. Manuals are subject to Manufacturer's reproduction limitations. Originals or reproductions were provided by manufacturers through a request. We make no warranty as to the correctness of information provided in this document and you assume all risk. By placing these manuals on line we are not declaring our corporation to be an manufacturer authorized dealer or provider, please check our web site for authorized manufacturers we represent.

ASSEMBLY INSTRUCTIONS
OPERATING INSTRUCTIONS
AND PARTS LIST FOR



VAC-35
MODEL PV-6430
MODEL PV-6430-K6
MODEL PV-6630-K6-LP

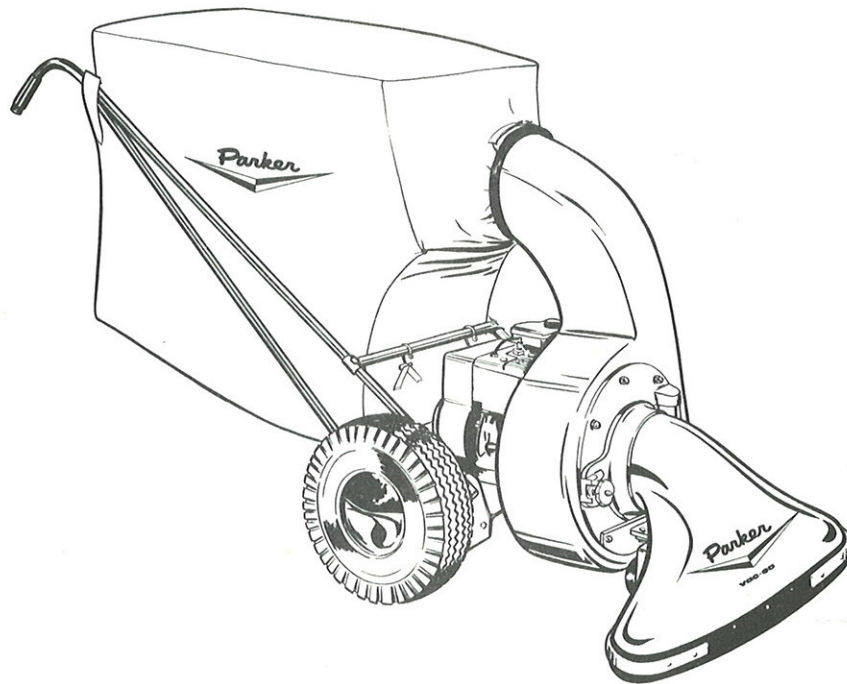

The following models of Vac-35 Vacuum Sweepers manufactured by Parker Sweeper Company, Springfield, Ohio are FACTORY MUTUAL APPROVED.

PV-6430

PV-6430 K-6

PV-6630 K-6 LP (Liquid Propane)

PV-6630 BP (Battery Powered)

and entitled to place this certification mark  on the above named products.

See Factory Mutual Engineering Division report. Serial No. 16647 dated December 30, 1965.

ASSEMBLY INSTRUCTIONS

- Your sweeper has been shipped in two cartons; one containing the sweeper unit and dust bag, the other containing the handle and a hardware bag. Check the contents of the hardware bag with the following packing list:

4 Handle Inserts, Ref. No. 26, Fig. 4
 2 Handle Clamps, Ref. No. 32, Fig. 4
 4 Bolts — Hex Hd., Ref. No. 3, Fig. 4, $\frac{1}{4}$ -20 x $1\frac{1}{4}$
 4 Nuts — Hex Lock, Ref. No. 40, Fig. 4, $\frac{1}{4}$ -20 Thin Type
 4 Bolts — Hex Hd., Ref. No. 31, Fig. 4, $\frac{3}{16}$ -18 x $1\frac{1}{4}$
 4 Nuts — Hex Lock, Ref. No. 22, Fig. 4, $\frac{3}{16}$ -18
 2 Screws — Oval Hd., Ref. No. 7, Fig. 4, #10-24 x 1"
 2 Nuts — Hex Lock, Ref. No. 6, Fig. 4, #10-24
 2 Tube Clamps, Ref. No. 37, Fig. 4
 2 Screws—Rd. Hd. Mach., Ref. No. 36, Fig. 4, #8-32 x $1\frac{1}{2}$
 2 Nuts — Hex Lock, Ref. No. 38, Fig. 4, #8-32

- Assemble the two trusses to bottom holes of the right and left handle and axle brackets with bolts and nuts (Ref. 31 and 22, Fig. 4) making sure a steel insert (Ref. 26, Fig. 4) is in the end of each truss as shown at point "C," Fig. 2. **DO NOT TIGHTEN.**

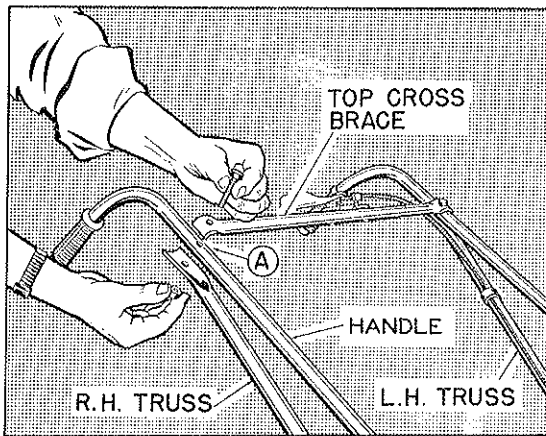

Fig. 1

- Assemble the two handles to top holes of the right and left handle and axle brackets with bolts and nuts (Ref. 31 and 22, Fig. 4) making sure a steel insert (Ref. 26, Fig. 4) is in the end of each handle as shown at point "D," Fig. 2. **DO NOT TIGHTEN.**
- Assemble the top cross brace, truss, and handle (both sides) with a bolt and nut (Ref. 3 and 40, Fig. 4) as shown at point "A," Fig. 1. **DO NOT TIGHTEN.** Notice the two holes on this brace are offset — assemble with holes to the right for Briggs engines and to the left for Kohler engines.
- Assemble the lower cross brace on top of the two handles, putting the two handle clamps (Ref. 32, Fig. 4) on the under side of the handles, with the bolts and nuts (Ref. 3 and 40, Fig. 4) as shown at point "B," Fig. 2. **TIGHTEN.**
- Now, tighten all bolts and nuts starting with those in step 2. This will keep handles in proper position.

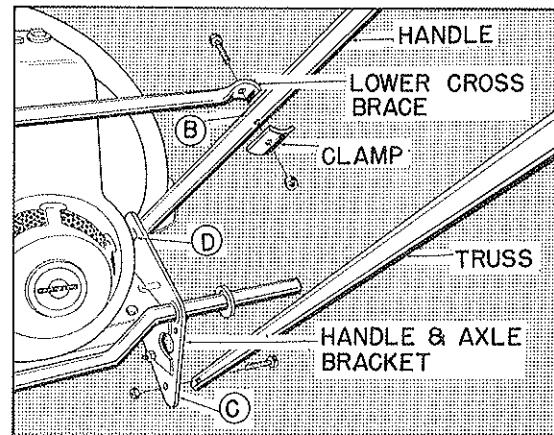

Fig. 2

- Take the throttle control cable from around the engine and run it up the top of the left hand truss brace. Place the two tube clamps (Ref. 37, Fig. 4) over the throttle cable and L.H. truss brace; one just below the lower cross brace position and the other about six inches from the top truss brace, secure with bolts and nuts. (Ref. 36 and 38, Fig. 4).
- Take the throttle lever and run it under the top cross brace; then line it up with the holes in the cross brace as shown in Fig. 3. Should the cable be too long, take the cross brace off and turn it around, then fit the throttle lever on with bolts and nuts. (Ref. 6 and 7, Fig. 4.) (See step 4.)

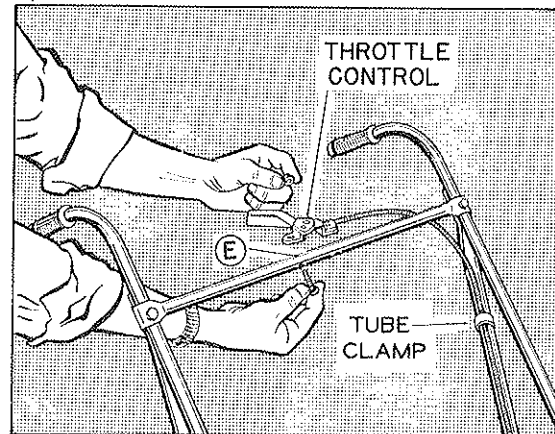

Fig. 3

- Attach the dust bag to the sweeper, placing loops over the handles and fastening the round opening of the bags securely to blower housing with bag strap. Place two hooks over lower cross brace.

OPERATING INSTRUCTIONS FOR PARKER VAC-35

IMPORTANT: Read the engine manual CAREFULLY before operating the Vac-35.

- KEEP FILTER BAG CLEAN.** The efficiency of this unit partly depends on the breathing capabilities of the dust bag. On extremely dusty jobs, empty bag often. Never allow debris to remain in bag after use.
- Make sure bag is in place when starting and stopping engine.
- Heavy concentrations of sand and gravel should be avoided. These materials are extremely abrasive, and while the Vac-35 will handle moderate amount of these materials, it was not designed for heavy applications. Because these materials are extremely heavy, they will likewise tend to collect in a lump in the bag, causing it to drag on the ground and wear out prematurely. Likewise, while the Vac-35 is capable of picking up empty tin cans

and blocks of wood, it was not intended for this type of service, since tremendous stresses are set up as these pieces pass through the impeller. Treat your Vac-35 with reasonable care and it will repay you with long, trouble-free service.

- Your Vac-35 is equipped with a front adjustable caster which will provide any height adjustment of intake housing that may be desired.
- For Briggs & Stratton engine. The kill switch for this engine is operated by the throttle lever. To stop engine back-off on the throttle as far as possible, this works an automatic kill switch on the engine. Should this switch fail to operate properly, consult your engine manual section IV under Standard Speed Control for proper adjustment. See Fig. 8.
 For all Kohler engines the "kill switch" is located on the lower left side of the engine below the exhaust. See Fig. 9.

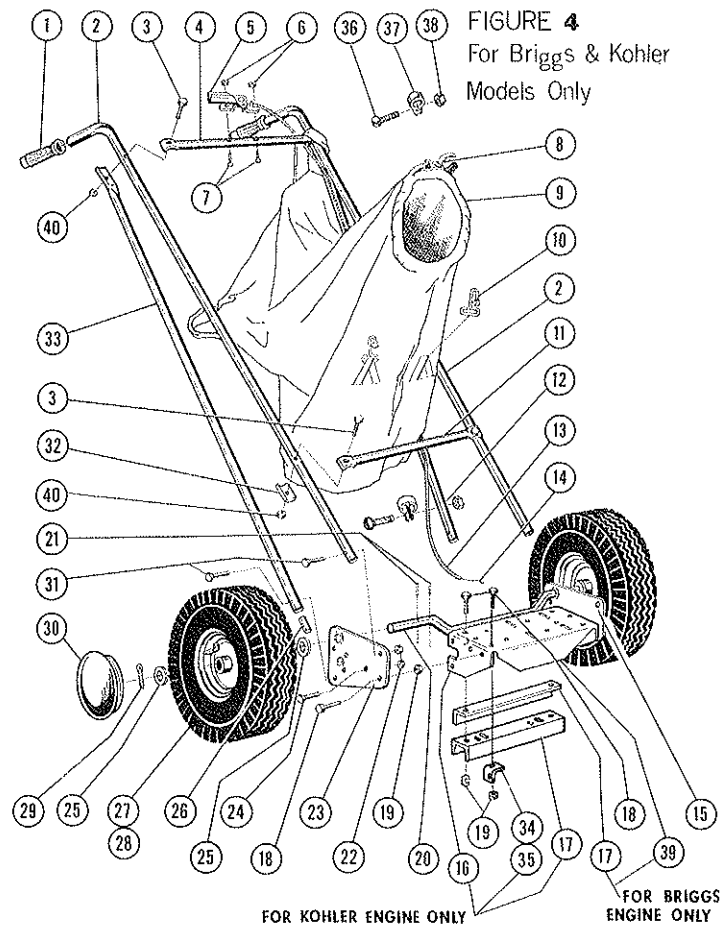

HANDLE AND FRAME ASSEMBLY

FIGURE 4

Ref. No.	Part No.	Qty. Per Unit	Description	Ref. No.	Part No.	Qty. Per Unit	Description
1	61-26-A	2	Grip—Handle	20	64-62-D	1	Axle
2	65-03-B	2	Handle	21	53-65-A	4	Pin—Roll $\frac{1}{8}$ x 1
3	65-416-20	4	Bolt—Hex Head $\frac{1}{4}$ -20 x $1\frac{1}{4}$	22	365-516	8	Nut—Hex Lock $\frac{3}{16}$ -18
4	61-12-B	1	Bar—Cross, Upper	23	64-60-RC	1	Bracket—Handle and Axle, Right Hand
5	61-28-A	1	Throttle Control Assembly $\varnothing 3.25$ -B-60	24	65-516-12	4	Bolt—Hex Head $\frac{3}{16}$ -18 x $\frac{3}{4}$
6	365-10	2	Nut—Hex Lock #10-24	25	945-1216	4	Washer—Flat S.A.E. $\frac{3}{4}$
7	517-10-16	2	Screw—Oval Head #10-24 x 1	26	61-13-A	4	Insert—Handle 75-30-A
8	63-274-A	1	Strap—Assembly—Bag SA-794-B	27	61-32-A	2	Wheel 68-447-B
9	64-77-F	1	Bag—Dust MA-419	28	61-33-A	2	Tire and Tube 68-310-B
10	63-304-A	2	Hook	29	380-432-20	2	Pin Cotter $\frac{1}{8}$ x $1\frac{1}{4}$
11	61-11-B	1	Bar—Cross, Lower	30	61-34-A	2	Cap—Hub
12	61-18-RC	1	Truss—Handle, Left Hand	31	65-516-20	4	Bolt—Hex Head $\frac{3}{16}$ -18 x $1\frac{1}{4}$
13	20-6-60	1	Cable—Throttle, $\frac{3}{16}$ Dia., 60" Long	32	59-77-A	2	Clamp—Tube
14	30-054-62 $\frac{1}{2}$	1	Wire—Throttle, .054 Dia., 62 $\frac{1}{2}$ " Long	33	61-18-RC	1	Truss—Handle, Right Hand
15	64-61-LC	1	Bracket—Handle and Axle, Left Hand	34	65-36-RA	1	Brace—Right Hand Kohler Engine Only
16	65-35-F	1	Bracket—Engine Mounting (Kohler)	35	65-37-LA	1	Brace—Left Hand (not shown) Kohler Engine Only
17	64-112-B	1	Support—Channel (Kohler)	36	515-8-8	2	Screw—Rd. Head Mach. #8-32 x $\frac{1}{2}$
17	63-123-A	1	Support—Angle (Briggs)	37	66-64-A	2	Clamp—Tube
18	65-416-12	8	Bolt—Hex Head $\frac{1}{4}$ -20 x $\frac{3}{4}$ Qty. 2 less for Briggs	38	365-8	2	Nut—Hex Lock #8-32
19	365-416	8	Nut—Hex Lock $\frac{1}{4}$ -20 Qty. 2 less for Briggs	39	63-03-E	1	Bracket—Engine Mounting (Briggs)
				40	364-416	4	Nut—Hex Thin Lock $\frac{1}{4}$ -20

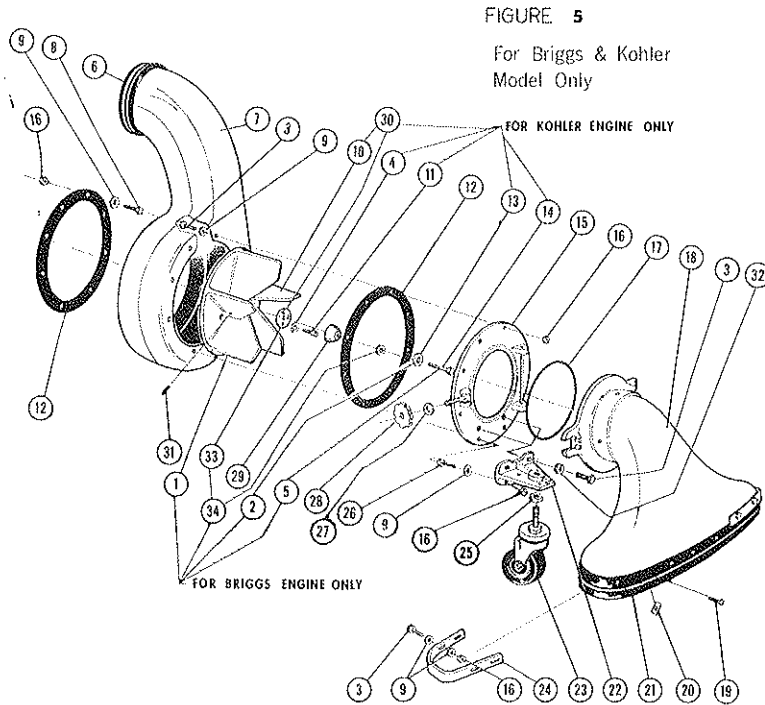

FIGURE 5
For Briggs & Kohler
Model Only

UNIT ASSEMBLY

FIGURE 5

Ref. No.	Part No.	Qty. Per Unit	Description	Ref. No.	Part No.	Qty. Per Unit	Description
1	61-14-E	1	Fan Wheel (Briggs Only)	16	365-416	24	Nut—Hex Lock $\frac{1}{4}$ -20
2	935-516	1	Washer—Spring Lock $\frac{3}{16}$ (Briggs Only)	17	63-190-A	1	"O" Ring
3	65-416-16	16	Bolt—Hex Head $\frac{1}{4}$ -20 x 1"	18	64-82-F	1	Housing—Intake Assembly <i>MA-251-D</i>
4	936-416	3	Washer—Lock Int. Tooth $\frac{1}{4}$ (Kohler Only)	19	515-10-12	15	Screw—Round Head #10-24 x $\frac{3}{4}$
5	64-126-A	1	Bolt—Hex Head Special $\frac{1}{8}$ -24 N.F. x 2 $\frac{1}{2}$ (Briggs Only)	20	346-10	15	Nut—Speed $\frac{1}{4}$
6	61-24-C	1	Ring—Rubber	21	61-23-B	1	Skirt—Rubber <i>73-67-D</i>
7	61-46-F	1	Housing—Blower Assembly <i>MA-238</i>	22	61-03-G	1	Bracket—Caster <i>66-436-C</i>
8	65-416-12	8	Bolt—Hex Head $\frac{1}{4}$ -20 x $\frac{3}{4}$ (Qty. 2 less for Kohler)	23	64-71-A	1	Caster
9	945-416	32	Washer—Flat S.A.E. $\frac{1}{4}$	24	62-98-C	2	Guard
10	63-88-E	1	Fan Wheel (Kohler Only) <i>72-175-D</i>	25	340-1216	1	Nut—Hex—Jam $\frac{3}{4}$ -10
11	524-416-12	3	Screw—Soc. Head Cap. $\frac{1}{4}$ -20 x $\frac{3}{4}$ (Kohler Only)	26	65-416-20	2	Bolt—Hex Head $\frac{1}{4}$ -20 x 1 $\frac{1}{4}$
12	62-187-C	2	Gasket—Rubber	27	945-816	1	Washer—Flat S.A.E. $\frac{1}{2}$
13	935-716	1	Washer—Spring Lock $\frac{3}{16}$ (Kohler Only)	28	59-47-B-2	1	Knob—Adjusting
14	65-39-A	1	Bolt—Hex Head Special $\frac{1}{8}$ -20 N.F. x 2 $\frac{3}{4}$ (Kohler Only)	29	61-10-A	1	Retainer—Fan
15	63-225-D	1	Cover—Front Assembly <i>SA-1389-D</i>	30	63-10-A	1	Plate—Retainer (Kohler Only)
				31	564-C-516-16	1	Screw Set $\frac{5}{16}$ -18 x 1"
				32	935-416	2	Washer—Spring Lock $\frac{1}{4}$
				33	63-10-A	1	Plate Retainer (Briggs Only)
				34	945-516	1	Washer Flat S.A.E. $\frac{3}{16}$ (Briggs Only)

FIGURE 6

Briggs Engine
Only

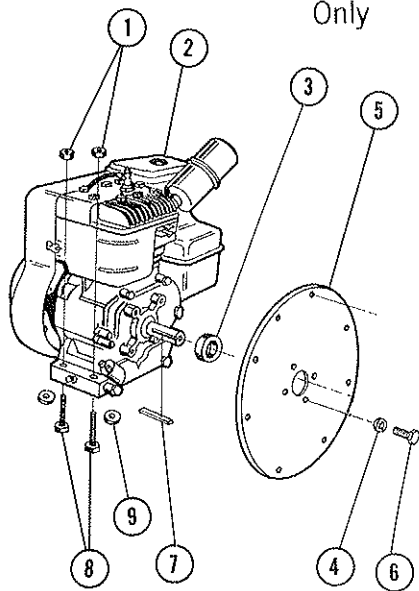

ENGINE ASSEMBLY

FIGURE 6

Ref. No.	Part No.	Qty. Per Unit	Description
1	365-516	4	Nut—Hex Lock $\frac{5}{16}$ -18
2	64-02-A	1	Engine—Briggs & Stratton
3	64-134-A	1	Spacer
4	936-516	4	Washer—Lock Int. Tooth $\frac{5}{16}$
5	61-02-C	1	Cover—Back
6	60-516-10	4	Bolt—Hex Head $\frac{5}{16}$ -24 N.F. x $\frac{3}{8}$
7	61-65-A	1	Key $\frac{3}{16}$ x $\frac{3}{16}$ x $1\frac{3}{4}$
8	65-516-24	4	Bolt—Hex Head $\frac{5}{16}$ -18 x $1\frac{1}{2}$
9	945-516	4	Washer S.A.E. Flat $\frac{5}{16}$

ALWAYS GIVE THE FOLLOWING INFORMATION WHEN ORDERING REPAIR PARTS:

IMPORTANT

1. PART NUMBER (Not Ref. No.)
2. QUANTITY NEEDED
3. DESCRIPTION OF PART
4. MODEL NUMBER

If unable to obtain parts locally, write down above information and send to:
PARKER SWEEPER CO., BOX 720, SPRINGFIELD, OHIO

Your unit is right hand (R.H.) or left hand (L.H.) as you stand behind it.

