



## Electronic Service Manuals

This electronic document is provided as a service to our customers. We do not create the contents of the information contained in this document. Should you have detailed questions pertaining to the information contained in this document, you may contact Michco, or the manufacturer which provided the original information in this electronic deliverable. Michco's only part in this electronic deliverable was the electronic assembly process. By providing this manual on line we are not guaranteeing parts availability.

You may contact Michco through the following methods:

Phone (517) 484-9312 or (800) 331-3339

2011 N. High St. -- Lansing, Michigan -- 48906

Fax: (517) 484-9836

Email: [CustServe@Michco.com](mailto:CustServe@Michco.com)

Web site: [www.Michco.Com](http://www.Michco.Com)

Parts Web site: [www.FloorMachineParts.Com](http://www.FloorMachineParts.Com)

Order Parts on Line at:

**[www.FloorMachineParts.Com](http://www.FloorMachineParts.Com)**

Directly to Parts & Service:

By Email: **[Shop@Michco.com](mailto:Shop@Michco.com)**

By Fax: (517) 702-2041

By Voice: Use numbers above.

**Serving the Cleaning Industry Since 1922**

Notice: All copyrighted material remains property of original owners, all trademarks are property of respective owners. Manuals are subject to Manufacturer's reproduction limitations. Originals or reproductions were provided by manufacturers through a request. We make no warranty as to the correctness of information provided in this document and you assume all risk. By placing these manuals on line we are not declaring our corporation to be an manufacturer authorized dealer or provider, please check our web site for authorized manufacturers we represent.

OPERATING INSTRUCTIONS  
AND PARTS LIST FOR

VAC-35



Parker

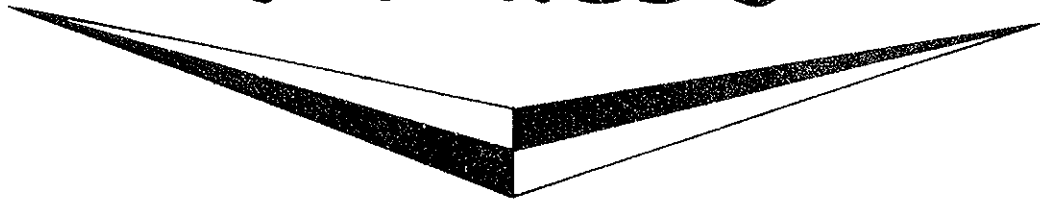

PV-304

6/30

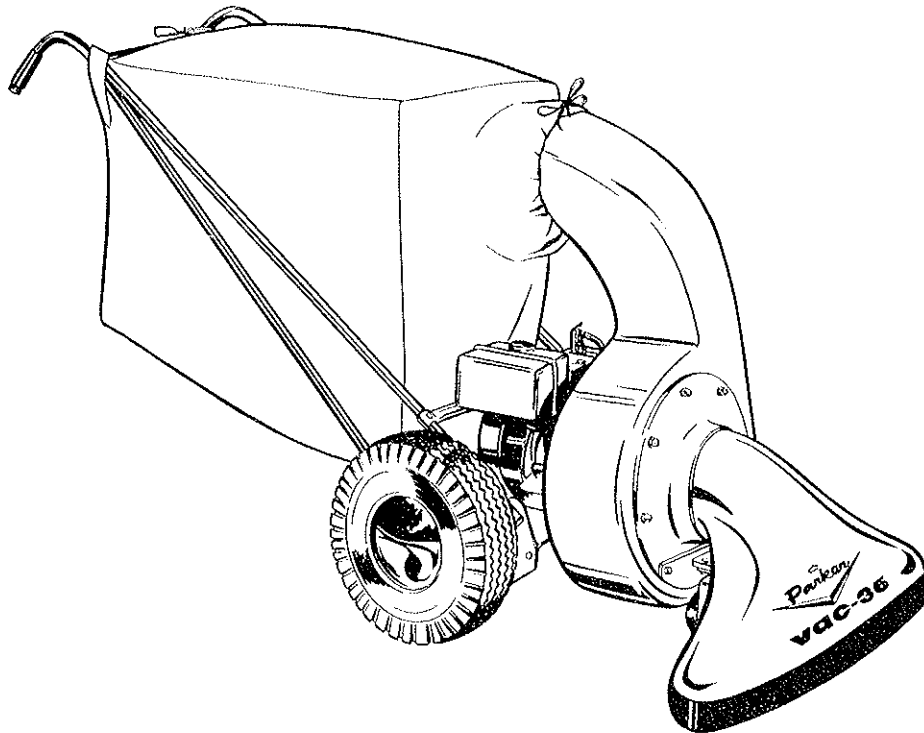

NOTICE: These instructions were written to assist you in assembling your Sweeper quickly and correctly. Read instructions thoroughly before attempting assembly so that you are familiar with the complete procedure.

PARKER SWEEPER COMPANY

BOX 720

SPRINGFIELD, OHIO

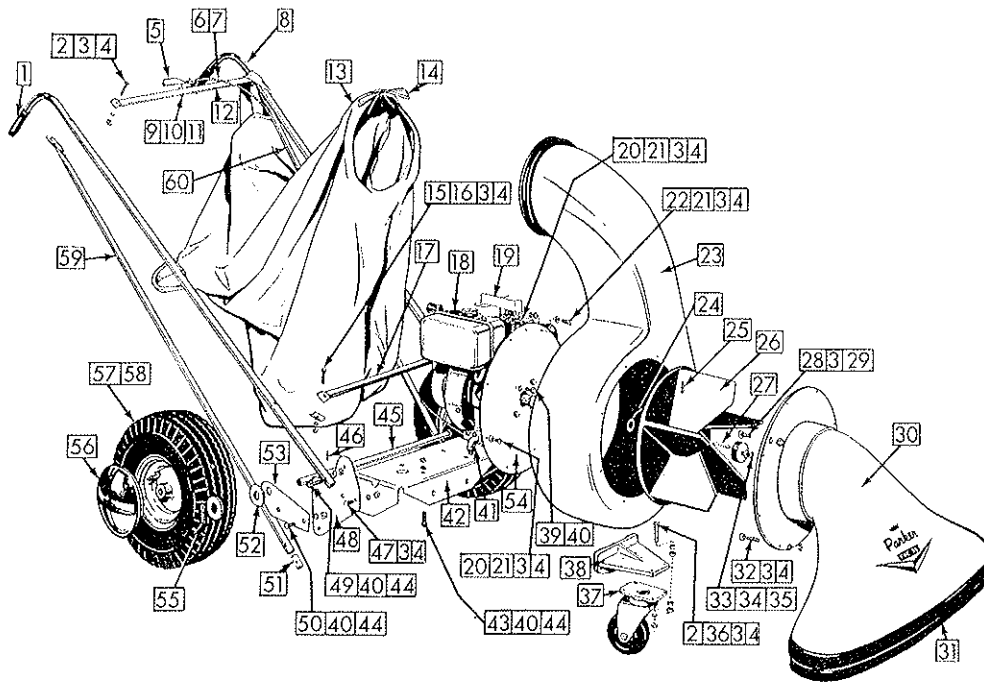

REF. No.	PART No.	DESCRIPTION OF PART	No. REQ.	REF. No.	PART No.	DESCRIPTION OF PART	No. REQ.
1	<del>61-26-A</del>	Handle Grip	2	32	73-416-20	Step Bolt 1/4 x 1 1/4	2
2	65-416-24	Hex Head Screw 1/4-20 x 1 1/2	6	33	<del>61-10-A</del>	Fan Retainer	1
3	936-416	Lock Washer	29	34	935-516	Spring Lock Washer	1
4	335-416	Hex Nut	23	35	60-516-24	Hex Head Bolt 3/8 NF x 1 1/4	1
5	<del>61-28-A</del>	Throttle Control Assembly	1	36	54-227-A	Spacer	16
6	<del>30-054-62 1/2</del>	Throttle Wire — .054 Dia. 62 1/2 Inches Long	1	37	<del>61-66-A</del>	Caster Assembly <i>69-119-A</i>	1
7	<del>20-6-60</del>	Throttle Cable — 3/8 Dia. 60 Inches Long	1	38	<del>61-03-C</del>	Caster Bracket <i>66-430-C</i>	1
8	<del>61-09-B</del>	Handle	2	39	60-516-10	Hex Head Bolt 3/8 NF x 3/8	4
9	515-10 -16	Round Head Screw 10-24 x 1	2	40	936-516	Lock Washer 3/8	16
10	936-10	Lock Washer	2	41	61-25-A	Elbow 90° 1/4"	1
11	335-10	Hex Nut 10-24	2	42	<del>61-04-E</del>	Engine Base	1
12	<del>61-12-B</del>	Upper Cross Brace	1	43	65-516-24	Hex Head Bolt 3/8 x 1 1/2	4
13	<del>61-45-F</del>	Bag <i>MA-419-1</i>	1	44	335-516	Hex Nut 3/8	12
14	<del>61-49-A</del>	Rope 50"	1	45	<del>61-15-B</del>	Axle	1
15	65-416-20	Hex Head Screw 1/4-20 x 1 1/4	2	46	<del>52-65-A</del>	Roll Pin 1/8 x 1 <i>71-06-A</i>	4
16	59-77-A	Clamp	2	47	65-416-8	Hex Head Bolt 1/4 x 1/2	4
17	61-11-B	Lower Cross Brace	1	48	<del>61-07-C</del>	Handle Support	2
18	<del>61-21-A</del>	Engine	1	49	65-516-20	Hex Head Bolt 3/8 x 1 1/4	4
19	<del>61-08-B</del>	Bracket	1	50	65-516-12	Hex Head Bolt 3/8 x 3/4	4
20	<del>515-416-12</del>	Round Head Screw 1/4-20 x 3/4	7	51	<del>61-13-A</del>	Insert <i>75-30-A</i>	4
21	945-416	Washer — Flat SAE 1/4	9	52	945-1216	Washer — Flat SAE 3/4	4
22	515-416-10	Round Head Screw 1/4-20 x 5/8	2	53	<del>61-05-RB</del>	Axle Support — Right Hand — Shown	1
23	<del>61-46-F</del>	Blower Housing <i>MA-238-C</i>	1		<del>61-06-LB</del>	Axle Support — Left Hand — Not Shown	1
24	<del>61-20-A</del>	Washer — Special	1	54	61-02-C	Back Cover	1
25	<del>564-C-516-16</del>	Set Screw 3/8 x 1	1	55	380-432-20	Cotter Pin	2
26	61-14-D	Fan Wheel	1	56	<del>61-34-A</del>	Hub Cap	2
27	61-65-A	Key 3/8 x 3/8 x 1 3/4	1	57	<del>61-32-A</del>	Wheel <i>68-497-B</i>	2
28	<del>73-416-12</del>	Step Bolt 1/4 x 3/4	6	58	61-33-A	Tire and Tube <i>68-312-A</i>	2
29	<del>61-42-A</del>	Acorn Nut 1/4-20	6	59	<del>61-18-RC</del>	Handle Truss Right Hand	1
30	<del>61-43-F</del>	Intake Housing Assembly <i>MA-292-F</i>	1	60	<del>61-17-LC</del>	Handle Truss Left Hand	1
31	<del>61-23-B</del>	Rubber Skirt <i>73-67-D</i>	1				

## ALWAYS GIVE THE FOLLOWING INFORMATION WHEN ORDERING REPAIR PARTS

Order all parts from your nearest dealer.

1. Part Number, Quantity and Fig. No.
2. Model Number (found on Side Plate).
3. Year Model, Serial Number (found on Guarantee Card).

Your unit is right hand (R. H.) or left hand (L. H.) as you stand behind it.

## ASSEMBLY INSTRUCTIONS FOR PARKER VAC-35

The Vac-35 is shipped complete in one carton.

**IMPORTANT:** This unit is designed and assembled for cleaning of hard surfaces, such as sidewalks, parking areas, factory floors, etc. where the air intake housing should be close to the surface (See Fig. A). However, with minor adjustments, it can be used on lawns or other soft surfaces which would yield to the weight of the machine. If a lawn sweeper is desired, follow the instructions pertaining to this AFTER you have read and completed the following assembly instructions.

### ASSEMBLY INSTRUCTIONS

Check contents of the hardware bag with the following packing list:

- 4 Handle Inserts (Ref. No. 51) (See exploded view)
- 2 Handle Clamps (Ref. No. 16)
- 2 Hex Head Bolts (Ref. No. 2)  $\frac{1}{4}$ -20 x  $1\frac{1}{2}$
- 2 Hex Head Bolts (Ref. No. 15)  $\frac{1}{4}$ -20 x  $1\frac{1}{4}$
- 4 Lock Washers (Ref. No. 3)  $\frac{1}{4}$
- 4 Hex Nuts (Ref. No. 4)  $\frac{1}{4}$ -20
- 4 Hex Head Bolts (Ref. No. 49)  $\frac{5}{16}$ -18 x  $1\frac{1}{4}$
- 4 Lock Washers (Ref. No. 40)  $\frac{5}{16}$
- 4 Hex Nuts (Ref. No. 44)  $\frac{5}{16}$ -18
- 2 Round Head Screws (Ref. No. 9) 10-24 x 1
- 2 Lock Washers (Ref. No. 10) #10
- 2 Hex Nuts (Ref. No. 11) 10-24

1. Assemble the two handles (Ref. No. 8) to the top holes of the right and left handle supports (Ref. No. 48) with bolts, nuts, and washers, (Ref. Nos. 49, 40, 44) making sure a steel insert (Ref. No. 51) is in the end of each handle. Do not tighten.
2. Assemble the two trusses (Ref. Nos. 59 and 60) to the bottom holes of the right and left handle supports (Ref. No. 48) with bolts, nuts, and washers (Ref. Nos. 49, 40, 44) again making sure a steel insert (Ref. No. 51) is in the end of each truss. Do

not tighten. NOTE: The truss with the throttle control must be on the left side opposite the gas tank.

3. Next assemble the lower cross brace (Ref. No. 17) on top of the two handles putting the two clamps (Ref. No. 16) on the under side of handles. Use bolts, nuts, and washers (Ref. Nos. 15, 4, 3) and tighten.
4. Place the upper brace (Ref. No. 12) on top of the two handles, putting the two small holes in the center of the brace in a vertical position. Use bolts, nuts, and washers (Ref. Nos. 2, 4, 3) making sure bolts run through brace, handles, and trusses. Tighten. NOTE: There are two holes in the upper end of each truss. Use the set of holes which position the handles more conveniently for the operator.
5. Connect the control wire to the throttle lever on the carburetor of the engine and lock the cable into the clamp on the carburetor. Then assemble the throttle onto the upper cross brace using the bolts, nuts, and washers (Ref. Nos. 9, 11, 10) and tighten.
6. Tighten all remaining bolts.
7. Attach the dust bag to the sweeper, placing loops over the handles and tying the round opening of the bag securely to the blower housing (Ref. No. 23).

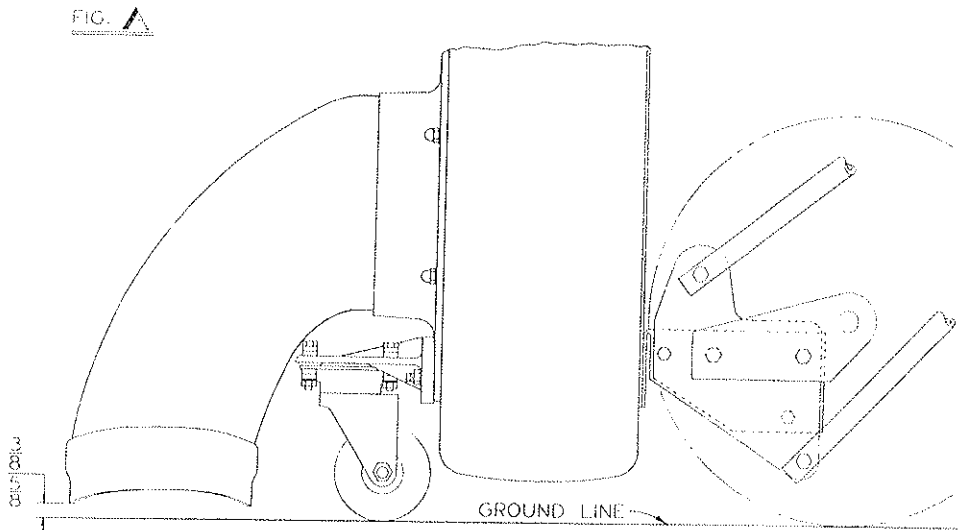

## INSTRUCTIONS FOR LAWN CLEANING

If the Vac-35 is used on lawns, make the following adjustments (See Fig. B) after you have assembled handles:

1. Loosen two bolts (Ref. No. 2) on upper cross brace.
2. Remove both wheels by snapping off the hub caps and removing cotter pins from the ends of the axle.
3. Remove the four bolts (Ref. No. 50) which hold the two axle supports (Ref. No. 53) to the engine base and with the axle still assembled through these two pieces, reverse them end for end and re-attach to engine base. In this new position, the axle will

be 2½ inches lower than before.

4. Re-assemble wheels and hub caps.
5. Remove the bolts (Ref. No. 2) from the caster bracket (Ref. No. 38) and rearrange the spacers (Ref. No. 36) until the rubber skirt (Ref. No. 31) on the intake housing is just touching ground. Then replace bolts and tighten. NOTE: In this position, it will be necessary for the operator to apply pressure downward on the handles thus raising the rubber skirt to the desired height and at the same time preventing the caster from digging into the lawn.

## OPERATING INSTRUCTIONS FOR PARKER VAC-35

**IMPORTANT:** Read the engine manual CAREFULLY before operating the Vac-35.

1. KEEP FILTER BAG CLEAN. The efficiency of this unit partly depends on the breathing capabilities of the dust bag. On extremely dusty jobs, empty bag often. Never allow debris to remain in bag after use.
2. Make sure bag is in place when starting and stopping engine.
3. Impulse starter will not start engine satisfactorily in temperatures below 40 degrees Fahrenheit.
4. Do not use the Vac-35 for removal of sand or light

gravel. These materials are extremely abrasive, and while the Vac-35 will handle moderate amounts of these materials, it was not designed for heavy applications. Because these materials are extremely heavy, they will likewise tend to collect in a lump in the bag, causing it to drag on the ground and wear out prematurely. Likewise, while the Vac-35 is capable of picking up empty tin cans and blocks of wood, it was not intended for this type of service, since tremendous stresses are set up as these pieces pass through the impeller. Treat your Vac-35 with reasonable care and it will repay you with long, trouble-free service.

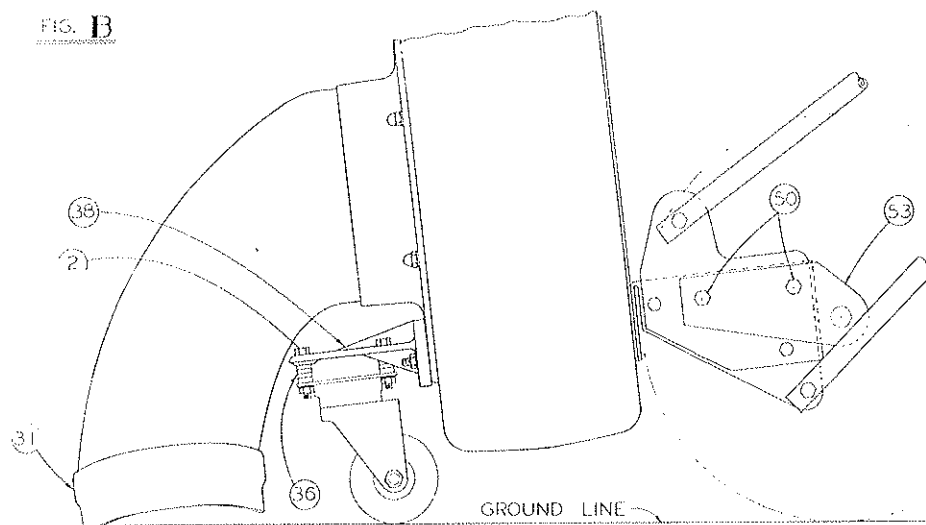

<b>VAC-35</b>	SIZE <b>30"</b>	PRODUCTION YEAR <b>1961</b>	MODEL No. <b>PV-3061</b>
---------------	--------------------	--------------------------------	-----------------------------

Ref. No.	Part No.	Qty. Req.	Description	Ref. No.	Part No.	Qty. Req.	Description
1	61-26-A	2	Handle Grip	31	61-23-B	1	Rubber Skirt
2	65-416-24	6	Hex Hd. Screw ¼ - 20 x 1½	32	73-416-20	2	Step Bolt ¼ x 1¼
3	936-416	29	Lock Washer	33	61-10-A	1	Fan Retainer
4	335-416	23	Hex Nut	34	935-516	1	Spring Lock Washer
5	61-28-A	1	Throttle Control Assy.	35	60-516-24	1	Hex Hd. Bolt ⅝ NF x 1¾
6	30-.054-62½	1	Throttle Wire — .054 Dia. 62½" long	36	54-227-A	16	Spacer
7	20-6-60	1	Throttle Cable — ⅝ Dia. 60" long	37	61-66-A	1	Caster Assy.
8	61-09-B	2	Handle	38	61-03-C	1	Caster Bracket
9	515-1024-16	2	Rd. Hd. Screw 10 - 24 x 1	39	60-516-10	4	Hex Hd. Bolt ⅝ NF x ⅝
10	936-10	2	Lock Washer	40	936-516	16	Lock Washer ⅝
11	335-10	2	Hex Nut 10 - 24	41	61-25-A	1	Elbow 90° ¼"
12	61-12-B	1	Upper Cross Brace	42	61-04-E	1	Engine Base
13	61-45-F <i>MA 419</i>	1	Bag	43	65-516-24	4	Hex Hd. Bolt ⅝ x 1¼
14	61-49-A	1	Rope 50"	44	335-516	12	Hex Nut ⅝
15	65-416-20	2	Hex Hd. Screw ¼ - 20 x 1¼	45	61-15-B	1	Axle
16	59-77-A	2	Clamp	46	53-65-A	4	Roll Pin ⅛ x 1
17	61-11-B	1	Lower Cross Brace	47	65-416-8	4	Hex Hd. Bolt ¼ x ½
18	61-21-A	1	Engine	48	61-07-C	2	Handle Support
19	61-08-B	1	Bracket	49	65-516-20	4	Hex Hd. Bolt ⅝ x 1¼
20	515-416-12	7	Rd. Hd. Screw ¼ - 20 x ⅝	50	65-516-12	4	Hex Head Bolt ⅝ x ¾
21	945-416	9	Washer — Flat SAE ¼	51	61-13-A	4	Insert
22	515-416-10	2	Rd. Hd. Screw ¼ - 20 x ⅝	52	945-1216	4	Washer — Flat SAE ¼
23	61-46-F	1	Blower Housing	53	61-05-RB	1	Axle Support — R.H. (shown)
24	61-20-A	1	Washer — Special		61-06-LB	1	Axle Sup't — L.H. (not shown)
25	564-C-516-16	1	Set Screw ⅝ x 1	54	61-02-C	1	Back Cover
26	61-14-E	1	Fan Wheel	55	380-432-20	2	Cotter Pin
27	61-65-A	1	Key ⅝ x ⅝ x 1¾	56	61-34-A	2	Hub Cap
28	73-416-12	6	Step Bolt ¼ x ¼	57	61-32-A	2	Wheel
29	61-42-A	6	Acorn Nut ¼ - 20	58	61-33-A	2	Tire and Tube
30	61-43-F	1	Intake Housing Assy.	59	61-18-RC	1	Handle Truss R.H.
				60	61-17-LC	1	Handle Truss L.H.

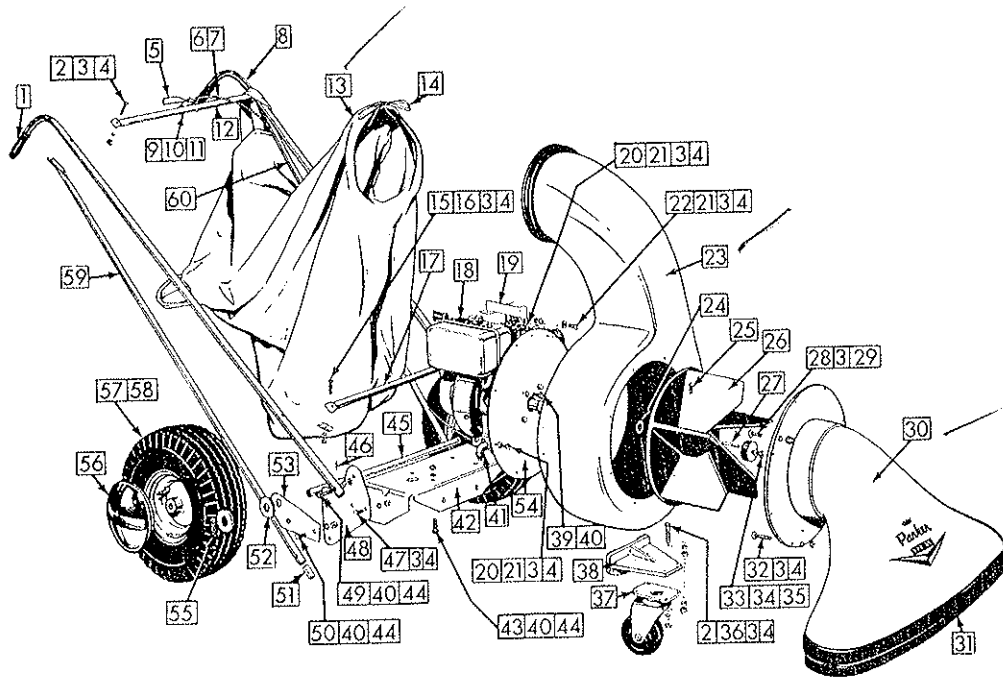

PV-3061