



Electronic Service Manuals

This electronic document is provided as a service to our customers. We do not create the contents of the information contained in this document. Should you have detailed questions pertaining to the information contained in this document, you may contact Michco, or the manufacturer which provided the original information in this electronic deliverable. Michco's only part in this electronic deliverable was the electronic assembly process. By providing this manual on line we are not guaranteeing parts availability.

You may contact Michco through the following methods:

Phone (517) 484-9312 or (800) 331-3339

2011 N. High St. -- Lansing, Michigan -- 48906

Fax: (517) 484-9836

Email: CustServe@Michco.com

Web site: www.Michco.Com

Parts Web site: www.FloorMachineParts.Com

Order Parts on Line at:

www.FloorMachineParts.Com

Directly to Parts & Service:

By Email: **Shop@Michco.com**

By Fax: (517) 702-2041

By Voice: Use numbers above.

Serving the Cleaning Industry Since 1922

Notice: All copyrighted material remains property of original owners, all trademarks are property of respective owners. Manuals are subject to Manufacturer's reproduction limitations. Originals or reproductions were provided by manufacturers through a request. We make no warranty as to the correctness of information provided in this document and you assume all risk. By placing these manuals on line we are not declaring our corporation to be an manufacturer authorized dealer or provider, please check our web site for authorized manufacturers we represent.

Minuteman[®] Parker[®]

VAC-35, 4" HOSE KIT Part No. MA-622-D

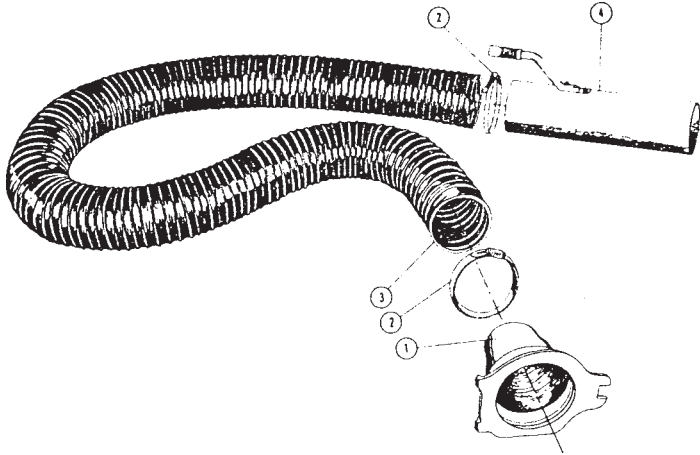

PARTS LIST

Item	Part No.	Qty.	Description
1	70-95-D	1	Collar, Reduction
2	64-36-A	2	Clamp, Hose
3	78-141-A	1	Hose
4	SA-715-B	1	Extension Assembly

ASSEMBLY INSTRUCTIONS TO ASSEMBLE HOSE KIT TO UNIT

1. Loosen Adjusting Knob on Front Cover Assembly and remove the standard collar.
2. Insert Hinge Bosses, on Reduction Collar (1), behind the Hinge Extensions or Hinge Rods on Front Cover Assembly.
3. Swing Collar (1) to lay flat against Front Cover Assembly.
4. Secure Flatwasher and Adjusting Knob over the Collar (1), and tighten Adjusting Knob.

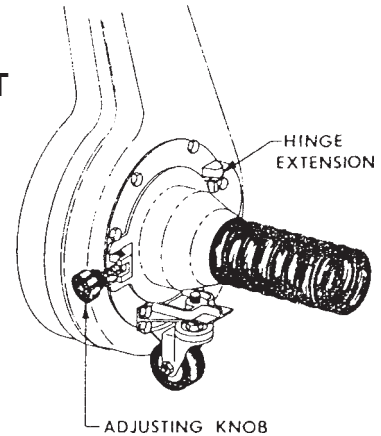

OPERATING INSTRUCTIONS

1. Follow the operating instructions of the unit, for engine speed, etc.
2. Stiff debris such as sticks and tree trimmings should not be picked up with the hose, as they may plug the hose.
3. Care should be taken not to plug the hose by forcing too much debris into it at one time.
4. If the hose becomes plugged, the engine must be shut off.
5. Remove hose from blower housing, remove all blockage from the hose and replace to blower housing before restarting engine.

IMPORTANT!

ALWAYS GIVE THE FOLLOWING INFORMATION WHEN ORDERING REPAIR PARTS:

1. PART NUMBER (not reference number)
2. QUANTITY NEEDED
3. DESCRIPTION OF PART
4. FOR PART NO. MA-622-D

If unable to obtain parts locally,
write down the above information and send to:
Parker Sweeper Co.
111 South Rohlwing Road
Addison, Illinois 60101

Minuteman[®] Parker[®]

A Minuteman International Company

World Headquarters
Minuteman International, Inc.
111 South Rohlwing Road
Addison, Illinois 60101

Minuteman Canada, Inc.
2210 Drew Road
Mississauga, Ontario
L5S 1B1

(630) 627-6900
FAX (630) 627-1130

(905) 673-3222
FAX (905) 673-5161

000679
Printed in U.S.A.