



Electronic Service Manuals

This electronic document is provided as a service to our customers. We do not create the contents of the information contained in this document. Should you have detailed questions pertaining to the information contained in this document, you may contact Michco, or the manufacturer which provided the original information in this electronic deliverable. Michco's only part in this electronic deliverable was the electronic assembly process. By providing this manual on line we are not guaranteeing parts availability.

You may contact Michco through the following methods:

Phone (517) 484-9312 or (800) 331-3339

2011 N. High St. -- Lansing, Michigan -- 48906

Fax: (517) 484-9836

Email: CustServe@Michco.com

Web site: www.Michco.Com

Parts Web site: www.FloorMachineParts.Com

Order Parts on Line at:

www.FloorMachineParts.Com

Directly to Parts & Service:

By Email: **Shop@Michco.com**

By Fax: (517) 702-2041

By Voice: Use numbers above.

Serving the Cleaning Industry Since 1922

Notice: All copyrighted material remains property of original owners, all trademarks are property of respective owners. Manuals are subject to Manufacturer's reproduction limitations. Originals or reproductions were provided by manufacturers through a request. We make no warranty as to the correctness of information provided in this document and you assume all risk. By placing these manuals on line we are not declaring our corporation to be an manufacturer authorized dealer or provider, please check our web site for authorized manufacturers we represent.

| | | | |
|--|---------------------|--------------------------------------|------------------------------|
| KLEEN-SWEEP HAND LAWN SWEEPER | SIZE 25" | PRODUCTION YEAR 1962-1963 | MODEL No. TK-6225 |
|--|---------------------|--------------------------------------|------------------------------|

| Ref. No. | Part No. | Qty. Req. | Description | Ref. No. | Part No. | Qty. Req. | Description |
|--------------|--------------------------|--------------|--|---------------|------------------------|--------------|---------------------------------------|
| 1 | 62-106-E | 1 | Handle - Upper | 25 | *355-416 | 8 | Nut - Square 1/4 - 20 |
| 2 | 62-103-D | 1 | Basket - Assembly | 26 | 59-26-B ^{cep} | 2 | Gear - Wheel |
| 3 | 62-104-A | 2 | Dowel - Basket R.H. | 27 | 59-20-C | 4 | Wheel - Rim |
| 4 | 62-100-LB | 1 | Bracket - Lower Basket L.H. | 28 | 59-54-C | 6 | Screw - Truss Phillips Hd. |
| 5 | 52-141-B | 2 | Brush Assembly <i>BK-12</i> | | | | 1/4 - 20 x 1/2 |
| 6 | 52-140-B | 1 | Reel Shaft | 29 | *380-332-16 | 2 | Cotter Pin 3/2 x 1 |
| 7 | *515-416-24 | 2 | Screw - Rd. Hd. 1/4 - 20 x 1 1/2 | 30 | 59-46-A | 2 | Hub Cap |
| 8 | 355-416-1 | 10 | Stamped Square Nut 1/4 - 20 | 31 | *515-416-6 | 2 | Screw - Rd. Hd. 1/4 - 20 x 3/8 |
| 9 | 62-112-B | 2 | Roller Assembly | 32 | 62-99-RB | 1 | Bracket - Lower Basket R.H. |
| 10 | 62-110-D | 1 | Hood Assembly | 33 | 62-107-E | 1 | Support - Frame |
| 11 | 59-43-D | 1 | Frame Assembly | 34 | *515-416-32 | 2 | Screw - Rd. Hd. 1/4 - 20 x 2 |
| 12 | 946-1316-20 | 4 | Washer - Fiber | 35 | 62-75-A | 2 | Roller - Wood |
| 13 | 54-197-B | 2 | Tire <i>R/W 63-224-B</i> | 36 | 62-76-A | 2 | Spacer - Wood Roller |
| 14 | 59-44-C | 2 | Wheel Assembly | 37 | 62-77-B | 2 | Bracket - Wood Roller |
| 15 | 55-161-A | 2 | Washer - Special | 38 | *515-416-16 | 4 | Screw - Rd. Hd. 1/4 - 20 x 1 |
| 16 | *335-516 | 2 | Nut - Hex 5/16 - 18 | 39 | *65-416-12 | 2 | Bolt - Hex Hd. 1/4 - 20 x 3/4 |
| 17 | *945-516 | 2 | Washer - SAE Plain 5/16 | 40 | 59-77-A | 2 | Clamp |
| 18 | 59-29-A | 2 | Spacer | 41 | 62-109-RB | 1 | Handle - Lower R.H. |
| 19 | 59-55-A | 2 | Screw - Truss Slot Hd. 5/16 - 18 x 3/4 | 42 | 62-105-B | 2 | Rod - Handle Support |
| 20 | *70-516-12 | 1 | Bolt - Carriage 5/16 - 18 x 3/4 | 43 | 62-108-LB | 1 | Handle - Lower L.H. |
| 21 | 936-716 | 1 | Washer Lock - Thin 5/16 | 44 | *515-416-20 | 2 | Screw - Rd. Hd. 1/4 - 20 x 1 1/4 |
| 22 | 59-47-B | 1 | Knob - Adjusting | 45 | *936-416 | 2 | Washer - Lock 1/4 |
| 23 | 45-25-A | 2 | Pawl | 46 | *335-416 | 2 | Nut - Hex 1/4 - 20 |
| 24 | 45-56-18-RC ^A | 1 | Pinion - R.H. (shown) | 47 | 62-84-B | 2 | Bracket - Upper Basket |
| | 45-56-19-LC ^A | 1 | Pinion - L.H. (not shown) | 48 | 60-12-A | 2 | Bearing - Nylon |

TK-6225

ALWAYS GIVE THE FOLLOWING INFORMATION WHEN ORDERING REPAIR PARTS

1. Part Number, Quantity.
2. Model Number (found on Hood).
3. Year, Model, Serial Number (found on Guarantee Card).

Your unit is right hand (R.H.) or left hand (L.H.) as you stand behind it.

*Standard hardware items may be purchased locally.

PARKER SWEEPER COMPANY

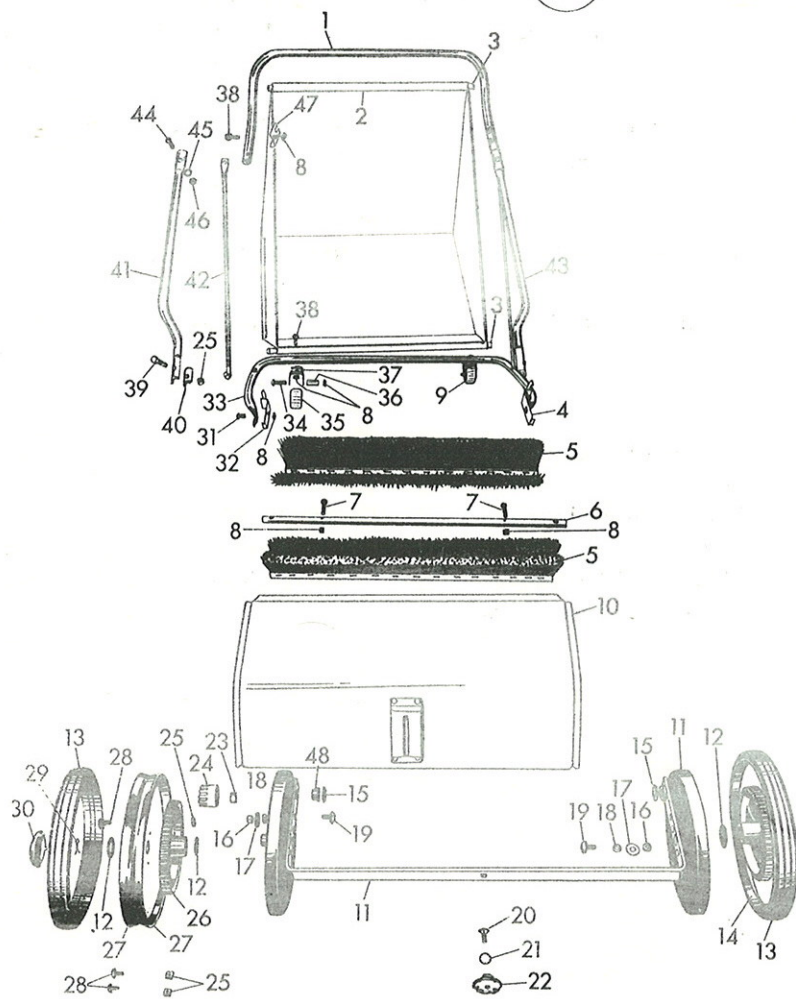
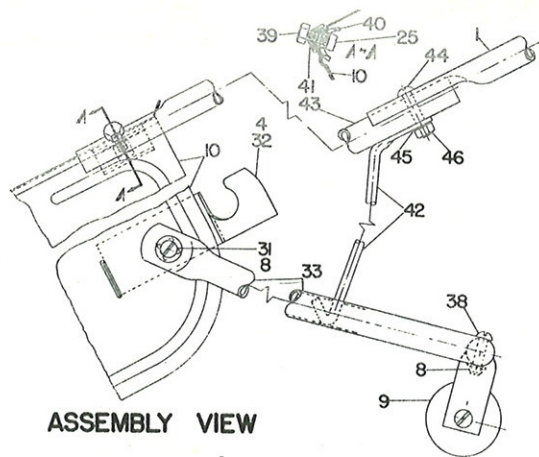

TK-6225