



Electronic Service Manuals

This electronic document is provided as a service to our customers. We do not create the contents of the information contained in this document. Should you have detailed questions pertaining to the information contained in this document, you may contact Michco, or the manufacturer which provided the original information in this electronic deliverable. Michco's only part in this electronic deliverable was the electronic assembly process. By providing this manual on line we are not guaranteeing parts availability.

You may contact Michco through the following methods:

Phone (517) 484-9312 or (800) 331-3339

2011 N. High St. -- Lansing, Michigan -- 48906

Fax: (517) 484-9836

Email: CustServe@Michco.com

Web site: www.Michco.Com

Parts Web site: www.FloorMachineParts.Com

Order Parts on Line at:

www.FloorMachineParts.Com

Directly to Parts & Service:

By Email: **Shop@Michco.com**

By Fax: (517) 702-2041

By Voice: Use numbers above.

Serving the Cleaning Industry Since 1922

Notice: All copyrighted material remains property of original owners, all trademarks are property of respective owners. Manuals are subject to Manufacturer's reproduction limitations. Originals or reproductions were provided by manufacturers through a request. We make no warranty as to the correctness of information provided in this document and you assume all risk. By placing these manuals on line we are not declaring our corporation to be an manufacturer authorized dealer or provider, please check our web site for authorized manufacturers we represent.

OWNERS GUIDE



LAWN PRIDE

QUALITY LAWN PRODUCTS

MODEL LP-7725

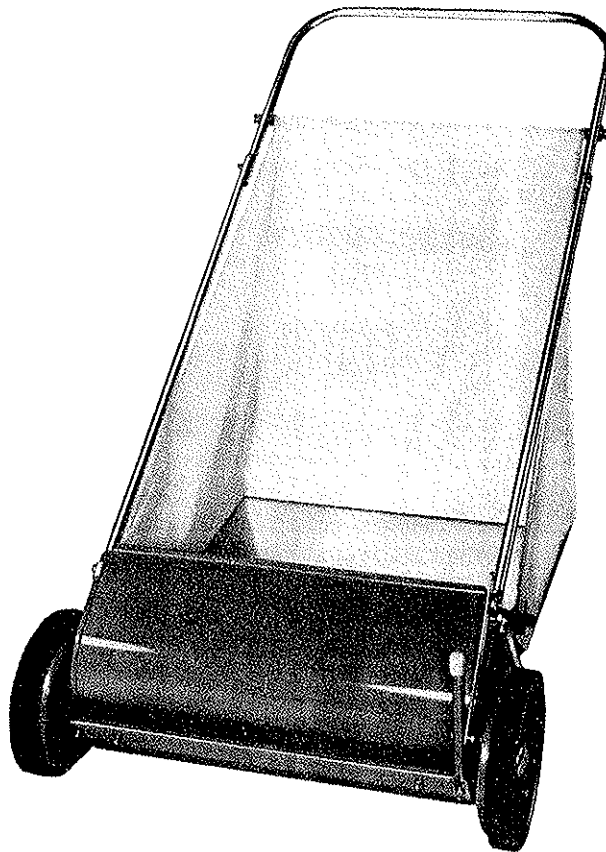

-Plate No. 192B-

ALWAYS GIVE THE FOLLOWING INFORMATION WHEN ORDERING REPAIR PARTS:

- | | |
|-------------------------------|------------------------|
| 1. PART NUMBER (Not Ref. No.) | 3. DESCRIPTION OF PART |
| 2. QUANTITY NEEDED | 4. MODEL No. LP-7725 |

If unable to obtain parts locally, write down above information and send to:
MIAMI INC.

Division of Parker Sweeper Company

P.O. Box 295

Springfield, Ohio 45501

Your unit is right hand (R.H.) or left hand (L.H.) as you stand behind it.

IMPORTANT

ASSEMBLY INSTRUCTIONS

ASSEMBLY INSTRUCTIONS

Place the Sweeper Head on the ground in an upright position.

Fig. 1 - (R.H. Side Shown). Remove the Bolt & Lock Nut holding the Bracket to the inside of the Sweeper Head.

Fig. 2 - (R.H. Side Shown). Turn the Bracket around so it will fit in the slot as shown and replace the Bolt & Lock Nut.

Repeat the same procedure for the L.H. side.

Fig. 1 - (R.H. Side Shown). Remove the Bolt & Square Nut in the upper corner of the Hood.

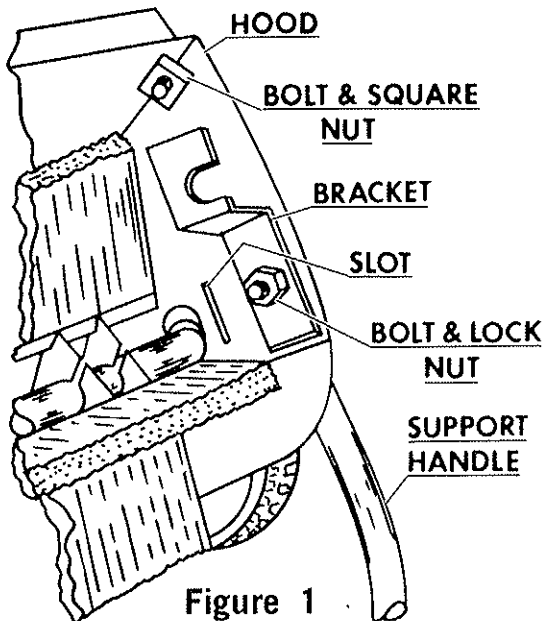

Figure 1

Fig. 2 - (R.H. Side Shown). Position the Handle-Lower so the square formed end fits in the upper corner of the Hood, then replace the Bolt & Square Nut.

Repeat the same procedure for the L.H. side.

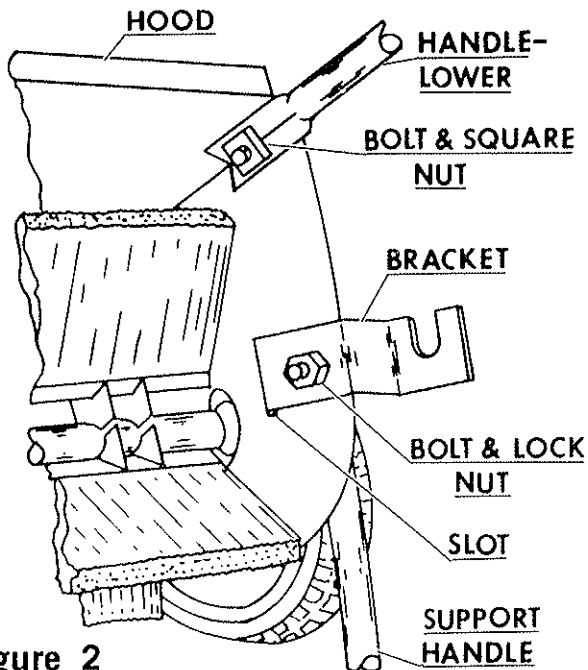

Figure 2

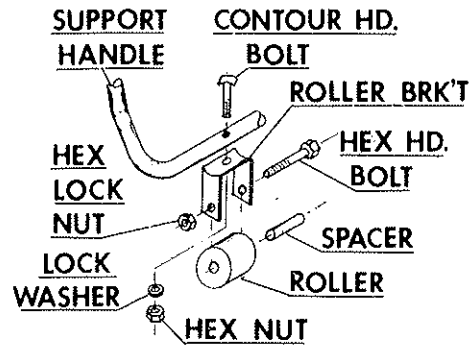

Figure 2A

Fig. 2A - (L.H. Side Shown). Attach 2 Rollers to the Support Handle as shown. (Ref. Fig. 6).

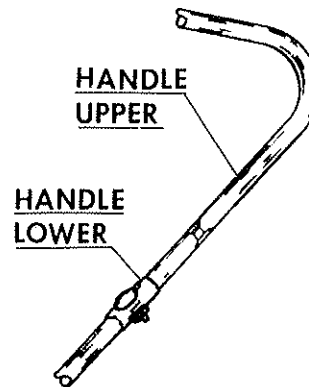

Figure 3

Fig. 3 & 6 - Fasten the Handle-Upper to the Handle-Lower, as shown.

Use the Hardware in the Plastic Bag for Fig. 2A, Fig. 3 & Fig. 6.

The Plastic Bag will contain the following hardware:

- 2 69-416-20 Bolt - Cont. Hd. $\frac{1}{4}$ -20 x $1\frac{1}{4}$
- 4 936-416 Washer - Int. Tooth Lock
- 4 335-416 Nut-Hex Plain $\frac{1}{4}$ -20
- 2 62-77-B Roller - Brkt.
- 2 69-416-16 Bolt-Cont. Hd. $\frac{1}{4}$ -20 x 1
- 2 65-416-32 Bolt-Hex Hd. $\frac{1}{4}$ -20 x 2
- 2 364-416 Nut - Hex Lock $\frac{1}{4}$ -20
- 2 62-76-A Spacer
- 2 62-75-A Roller

Fig. 4 and Picture shown on front cover. Attach the Basket to the Sweeper by putting the lower wood Rod in the Brackets on each side of the Hood and in the Supports on the under side of the Upper Handle.

OPERATING INSTRUCTIONS

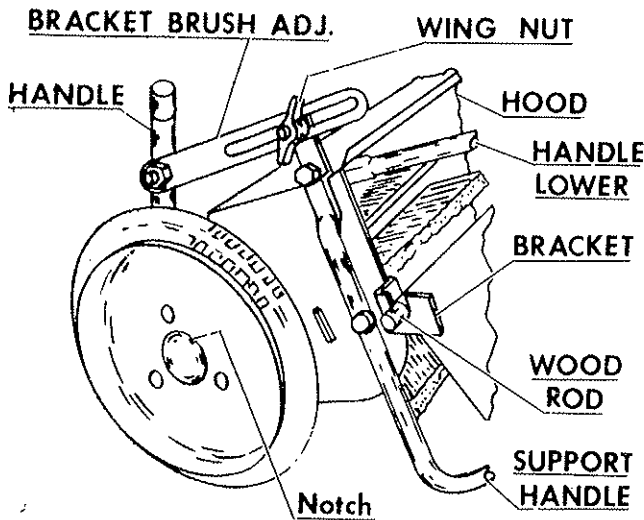

Figure 4

BRUSH HEIGHT ADJUSTMENT

Fig. 4 - Loosen the Wing Nut holding the Bracket, Brush Adj. on the upper left side of the Hood. Move the Handle forward or backward to set the desired brush height, then tighten the Wing Nut. The correct brush height is when the brush is just touching the top of the grass. After a trial run on the lawn, it may be necessary to adjust the brush setting. **NOTE:** If Sweeper pushes hard, the brush is set too low.

CARE AND BRUSH REPLACEMENT

Should the brushes become bent from use, reverse the brushes on the reel shaft. Never allow the brush bristles to remain in a bent position, as they can take a set.

TO REMOVE BRUSHES

Turn the Sweeper upside down on the ground. Notice the Stud has either 2 swage bumps or a collar against the Support holding it against the Reel Shaft.

Fig. 5 - Remove the Hex Nuts, Washers and Clamps from the Stud on the end having the 2 swage or collar. Remove the Brushes from the Brush Bracket Slots, (3 places). Now remove the Hex Nuts, Washers and Clamps from the opposite end of the Studs. Do not remove the Speed Nuts or the Studs will fall away from the Reel Shaft (3 places).

TO REPLACE BRUSHES

Fig. 5 - Turn the Reel Shaft so you can position the Brush Strips in the slots on the Brush Bracket that are being held on the Stud and Shaft by the Speed Nut. Position the Clamps, Washers and Hex Nuts, center the Brush Strips between the Side Plates, then tighten the Hex Nuts.

Turn the Reel Shaft so the Brushes are on the bottom side. Now place the Brush Strips in the slots on the Brush Brackets, on the top side. Position the Clamps, Washers and Hex Nuts. Center the Brush Strips between the Side Plates, then tighten the Hex Nuts.

BASKET CARE

The Basket should always be emptied immediately after each time the Sweeper is used, especially if the grass or leaves are wet or damp. Allowing the Basket to keep dry will lengthen its service life.

LUBRICATION

Ref. Fig. 4 & 6 - Place a few drops of oil in the 2 Oil Holes on the inside of each Wheel Cover (Frame Assembly, Item 4) and in the notch on each Hub Cap, each time before using the Sweeper. Frequent oiling of the Sweeper will lengthen the service life.

STORAGE

Your Sweeper can be stored in a minimum of space. Remove the Basket from the Sweeper, be sure it is empty of debris, then hang it on the wall. The Sweeper can also be hung on the wall by its Handle.

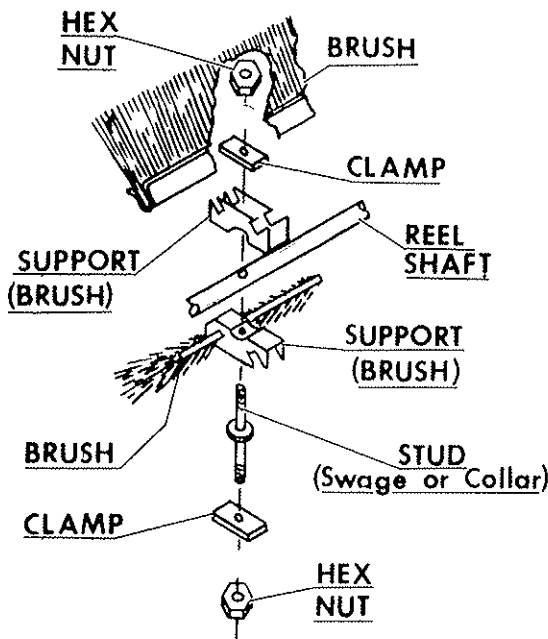
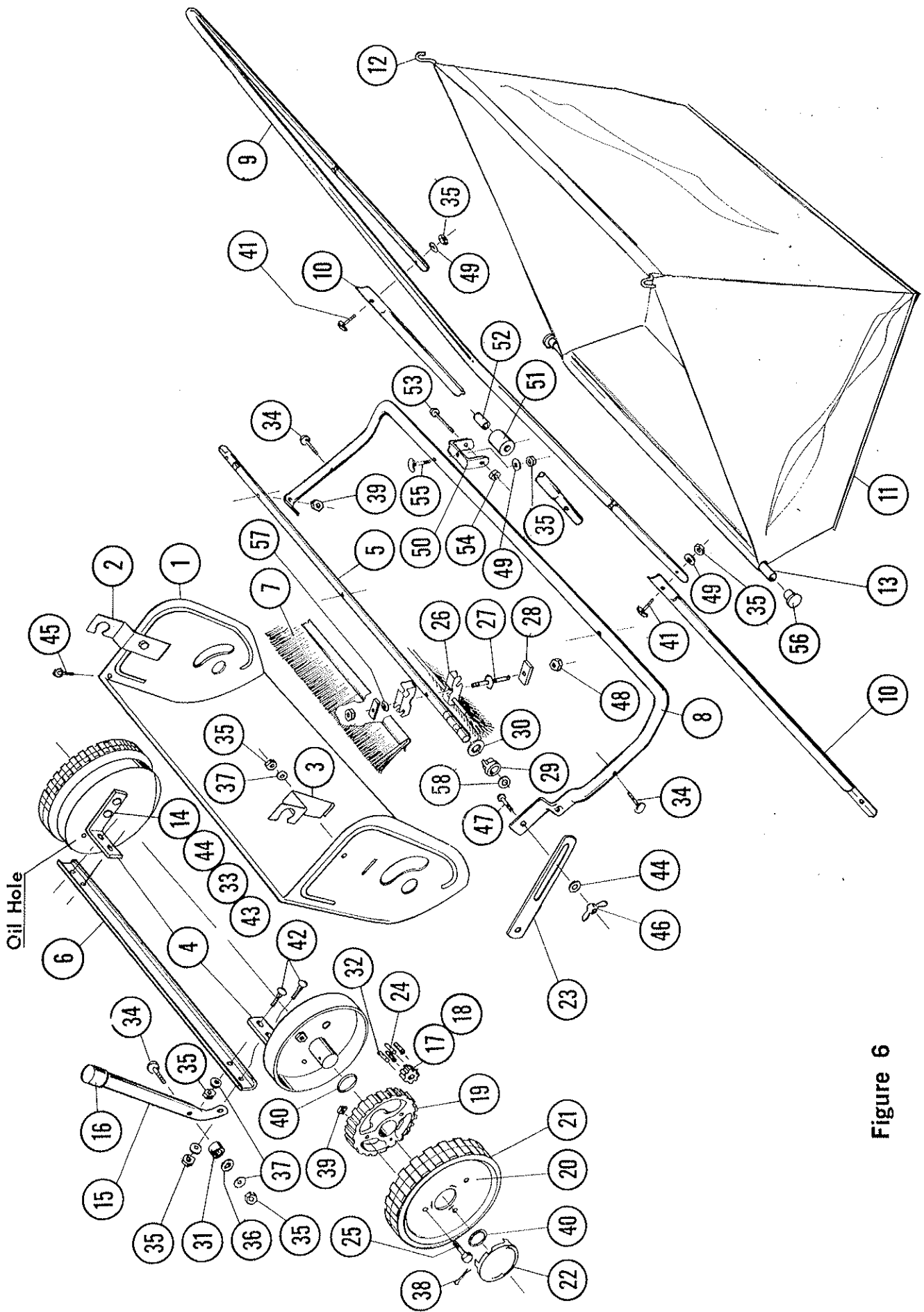

Figure 5

SWEEPER ASSEMBLY



-Plate No. 196B-

Figure 6

PARTS LIST

PARTS LIST
Figure 6

Ref. No.	Part No.	Description of Part	Qty. Per Unit	Ref. No.	Part No.	Description of Part	Qty. Per Unit
1	76-356-C	Hood Assem.	1	30	55-161-A	Washer-Special	2
2	62-99-RB	Bracket	1	31	59-29-A	Spacer	1
3	62-100-LB	Bracket	1	32	76-37-A	Pawl Springs	4
4	74-04-C	Frame Assem.	2	33	59-29-A	Spacer	2
5	75-98-B	Reel Shaft	1	34	69-416-20	Bolt-Cont. Hd. 1/4-20 x 1 1/2	3
6	74-07-B	Frame-Tie Bar	1	35	335-416	Nut-Hex 1/4-20	11
7	1200-24	Brush Strip Assem.	4	36	945-416	Washer-Flat 1/4	3
8	74-26-D	Support-Handle	1	37	935-416	Washer-Spring Lock 1/4	8
9	76-148-B	Handle-Upper	1	38	380-332-16	Cotter Pin 3/32 Dia. x 1	2
10	74-24-B	Handle-Lower	2	39	355-416	Nut-Square 1/4-20	8
11	76-291-D	Basket Assem.	1	40	946-1216-20	Washer-Fiber 3/4 I.D.	6
12	76-23-A	Basket Support	1	41	69-416-20	Bolt-Cont. Hd. 1/4-20 x 1 1/4	2
13	74-81-A	Rod Basket Lower	1	42	70-416-12	Bolt-Carriage 1/4-20 x 3/4	4
14	59-55-A	Screw-Sems	2	43	335-516	Nut-Hex Plain 5/16-18	2
15	74-19-B	Handle Adj.	1	44	945-516	Washer-Flat 5/16	3
16	75-74-A	Tube-Cap	1	45	65-416-16	Bolt Hex Hd. 1/4-20 x 1	2
17	74-79-LA	Pinion Gear (L.H.)	1	46	73-71-A	Nut-Wing 5/16-18	1
18	74-78-RA	Pinion Gear (R.H. Not shown)	1	47	70-516-16	Bolt-Carriage 5/16-18 x 1	1
19	74-39-B	Gear Wheel	2	48	362-416	Nut-Hex Plain 1/4-20	6
20	59-20-C	Wheel Rim	4	49	936-416	Washer Int. Tooth Lock 1/4	10
21	63-224-B	Tire-Rubber	2	50	62-77-B	Roller - Brkt.	2
22	59-46-A	Hub Cap	2	51	62-75-A	Roller - Wood	2
23	60-21-A	Bracket-Brush Adj.	1	52	62-76-A	Spacer	2
24	74-80-A	Roller Pawls	4	53	65-416-32	Bolt-Hex Hd. 1/4-20 x 2	2
25	59-54-A	Screw-Truss Hd. 1/4-20 x 1/2	6	54	364-416	Nut-Hex Lock 1/4-20	2
26	74-13-C	Support-Brush	6	55	69-416-16	Bolt-Cont. Hd. 1/4-20 x 1	2
27	74-16-A	Stud	3	56	75-75-A	Cap End	2
28	69-04-A	Clamp-Brush Strip	6	57	75-89-A	Speed Nut	3
29	69-233-A	Bearing-Nylon	2	58	50-33-A	Washers-Special	2

ASSEMBLY INSTRUCTIONS FOR PINION-ROLLER PAWLS & PAWL SPRINGS

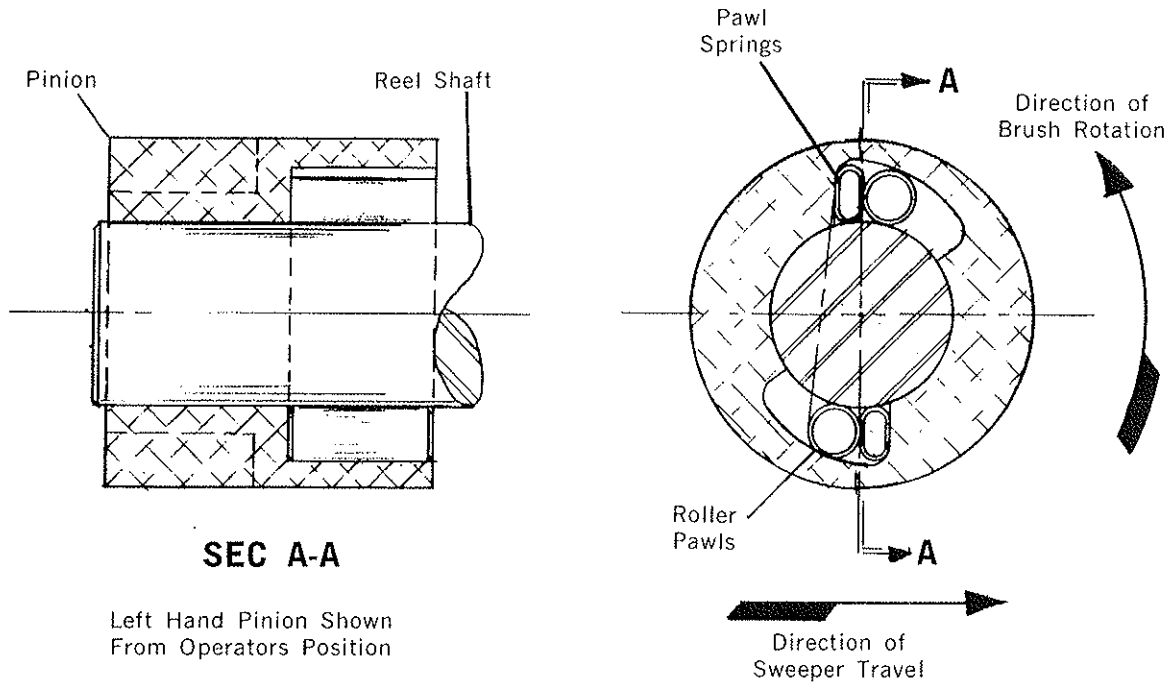
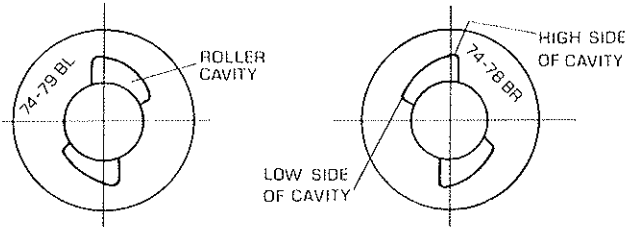

Figure 7

Ref. Fig. 7 - If for any reason it is necessary to remove the Pinion Gear, be sure the Pinion Gear Roller Pawls and Pawl Springs are reassembled in their correct position as shown in Fig. 7. Both right and left Pinion Gears must be turning the right direction so the Brush Reel is turning toward the operator when the Sweeper is pushed forward.

HOW TO RE-INSTALL PINIONS

If, for some reason, it becomes necessary to remove the Pinions from the Reel Shaft, they can be easily replaced following the instructions below:



1. **NOTE** that the Pinions are stamped with the letters BR & BL. The BR Pinion is a Right Hand Pinion and is to be installed at the right hand side of the Reel Shaft. The BL Pinion is a Left Hand Pinion and is to be installed at the left hand side of the Reel Shaft.

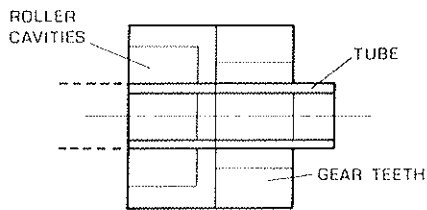

2. Install the Pinion over the $\frac{5}{8}$ " diameter Tube and position the Tube flush with the side of the Pinion at the side with the Roller cavities.

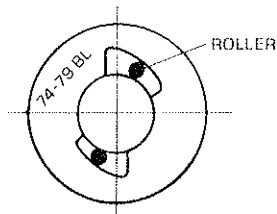

3. Now install a Roller in the cavity and turn the Pinion until the Roller is tight between the Tube and the outside of the cavity.

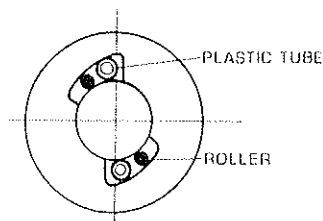

4. With the Roller tight between the Tube and the wall of the cavity, insert one of the plastic Tubes between the Roller and the high side of the cavity.

Now, following the instructions #3 & #4, install the second Roller and plastic Tube in the second cavity.

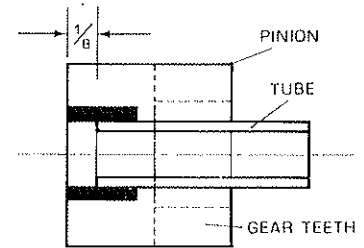

5. Push the Tube back into the Pinion, so that it is $\frac{1}{8}$ " inside the Pinion, on the side where the Rollers are located.

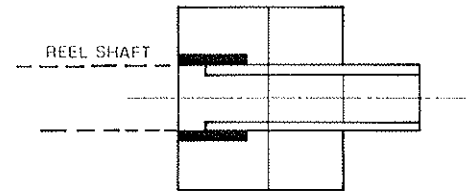

6. Place the Pinion, Roller end first, over the end of the Reel Shaft and push the Pinion off the Tube and onto the Reel Shaft. Be sure to put the Right Hand Pinion on the right hand end of the Reel Shaft.

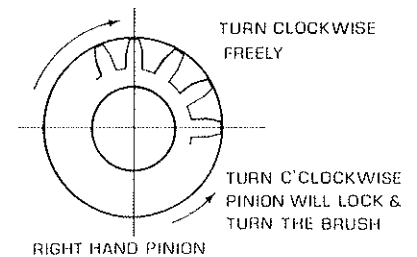

7. Turn the Right Hand Pinion clockwise; it should rotate freely. Turn it counterclockwise, and it should rotate the Brush.

8. Follow steps #2 thru #6, and install the Left Hand Pinion.

9. Turn the Left Hand Pinion counterclockwise and it should rotate freely. Turn it clockwise, and it should rotate the Brush.

10. Grease the Gear and the Pinion Teeth, and replace the Wheels.

