



Electronic Service Manuals

This electronic document is provided as a service to our customers. We do not create the contents of the information contained in this document. Should you have detailed questions pertaining to the information contained in this document, you may contact Michco, or the manufacturer which provided the original information in this electronic deliverable. Michco's only part in this electronic deliverable was the electronic assembly process. By providing this manual on line we are not guaranteeing parts availability.

You may contact Michco through the following methods:

Phone (517) 484-9312 or (800) 331-3339

2011 N. High St. -- Lansing, Michigan -- 48906

Fax: (517) 484-9836

Email: CustServe@Michco.com

Web site: www.Michco.Com

Parts Web site: www.FloorMachineParts.Com

Order Parts on Line at:

www.FloorMachineParts.Com

Directly to Parts & Service:

By Email: **Shop@Michco.com**

By Fax: (517) 702-2041

By Voice: Use numbers above.

Serving the Cleaning Industry Since 1922

Notice: All copyrighted material remains property of original owners, all trademarks are property of respective owners. Manuals are subject to Manufacturer's reproduction limitations. Originals or reproductions were provided by manufacturers through a request. We make no warranty as to the correctness of information provided in this document and you assume all risk. By placing these manuals on line we are not declaring our corporation to be an manufacturer authorized dealer or provider, please check our web site for authorized manufacturers we represent.

OWNER'S GUIDE



HURRICANE® MODEL NO HT-8950

AF-910



**READ THESE INSTRUCTIONS
BEFORE SETTING UP AN OPERATING MACHINE**

PARKER SWEEPER COMPANY

Box 1728

Springfield, Ohio 45501-1728

Plate No. 1517

89-69-A

TO THE OWNER

RULES FOR SAFE OPERATION



The following safety precautions are suggested to prevent damage to the equipment or injury to the operator or nearby persons.

1. TO PREVENT ACCIDENTAL STARTING ALWAYS REMOVE THE SPARK PLUG before working on the engine or equipment driven by the engine.
2. DO NOT RUN THE ENGINE IN AN ENCLOSED AREA. Exhaust gases contain carbon monoxide which is an odorless and deadly poison.
3. DO NOT FILL GASOLINE TANK WHILE ENGINE IS HOT OR RUNNING. Spilling gasoline on a hot engine may cause a fire or explosion.
4. DO NOT leave machine unattended while running.
5. DO NOT ALLOW machine to blow in direction of people or objects that could be injured by blown materials.
6. AVOID operating machine in dangerous places where steep slopes or loose debris will endanger the safety of operator or other people.

ALWAYS GIVE THE FOLLOWING INFORMATION WHEN ORDERING REPAIR PARTS:

- | | |
|-------------------------------|---------------------------|
| 1. PART NUMBER (Not Ref. No.) | 3. DESCRIPTION OF PART |
| 2. QUANTITY NEEDED | 4. MODEL NO. OF HURRICANE |

If unable to obtain parts locally, write down the above information and send to:
PARKER SWEEPER CO., P.O. Box 1728, Springfield, Ohio 45501-1728

IMPORTANT!

ASSEMBLY INSTRUCTIONS

The unit covered in this owner's guide is shipped complete in one carton and will take a minimum amount of time and effort to assemble. Follow all instructions carefully. All hardware is on the unit in its proper location. If something is missing, notify the dealer/distributor where unit was purchased. If unable to obtain parts locally, contact the Parker Sweeper Company.

GENERAL INFORMATION

1. With carton open and top insert removed, remove the Upper Handles and Front Wheel. Also, remove the side inserts that fit over Wheels.
2. Lay carton over so the back of unit is toward floor.
3. Lift up and pull back on Lower Handles to disengage Wheels from the lower inserts. Pull unit out of carton.
4. Set carton and inserts aside. Do Not discard any of the inserts or the carton until the unit is completely assembled.
5. Read through the Owner's Guide once to familiarize yourself with the assembly procedure, maintenance and operation of the unit.
6. Many times the exploded view to the back of this Owner's Guide can aid in the assembly of the unit.

CAUTION! Never work on the unit without first removing the spark plug wire from the spark plug. This will prevent false starting of the engine. Check to make sure spark plug wire is disconnected before continuing these instructions.

OBSERVE SAFETY RULES AT ALL TIMES. DON'T TAKE CHANCES!

ASSEMBLY INSTRUCTIONS

ASSEMBLING FRONT WHEEL TO UNIT

NOTE: The numbers in parenthesis refer to those used in the adjoining AF-909 and the exploded view of HT-8950 on plate number 1519 to the back of this Owner's Guide.

1. Remove Hex Hd. Bolts, Flatwashers and Hex Lock Nuts from Wheel Arm Assembly (13).
2. Insert Hex Hd. Bolts up through two holes in Wheel Arm Assembly (13).
3. Place Wheel Arm Assembly (13) to bottom of Blower Housing (8), inserting Bolts through holes in Housing (8).
4. Assemble one Flatwasher to each Bolt and secure with Hex Lock Nuts.

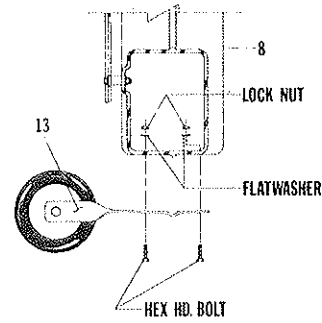

AF-909

ASSEMBLING UPPER HANDLES TO UNIT

NOTE: The numbers in parenthesis refer to those used in the adjoining AF-908 and the exploded view of HT-8950 on plate number 1519 to the back of this Owner's Guide.

1. Remove the four Hex Hd. Bolts (31) and Lock Nuts (43) from lower ends of Upper Handles (24 & 25).
2. Slide Upper Handles (24 & 25) down over ends of Lower Handles (14). Align holes and reassemble Hex Hd. Bolts (31) and Lock Nuts (43). **DO NOT TIGHTEN.**
3. Remove the Hex Hd. Bolt (31) and Lock Nut (43) from top hole in Upper Handle L.H. (25).
4. Align hole in Cross Brace (26) with hole in Upper Handle L.H. (25) and reassemble Hex Hd. Bolt (31) and Lock Nut (43).
5. Tighten all hardware.

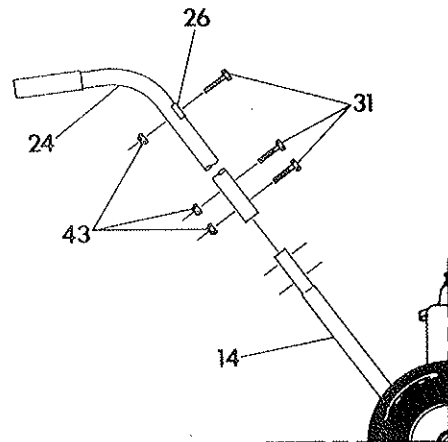

AF-908

ASSEMBLING THROTTLE CONTROL

1. Remove Throttle Control from its shipping position and run it up left hand handles.
2. Align holes in control with those in upper left handle and secure with Oval Hd. Screws and Lock Nuts furnished.
3. Secure control cable to lower left handle with Snap-on Clamp.
4. Be sure there are no bends less than 8" in radius.

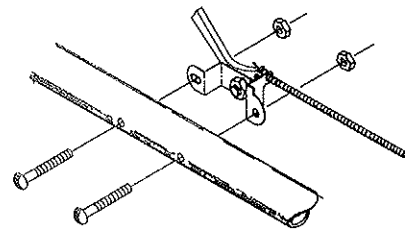

AF-649

OPERATION AND MAINTENANCE INSTRUCTIONS

WARNING: The engine contains no oil when shipped. Read the Engine Instruction Manual and add the proper type and amount of oil and gas before starting engine.

1. Read engine manual carefully. Be sure to know how to start and stop engine before operating unit.
2. Replace spark plug wire to spark plug.
3. Engine should be "broken in" by running at 1/2 throttle for 30 minutes and full throttle for an additional 30 minutes.
4. The unit is designed to operate at full throttle, and will work effectively by either pushing or pulling.
5. To clean an area, start at the outer perimeter and blow the material toward the center. Clean a row against buildings and fencerows and work to the center from clean path.

6. When cleaning large areas or if debris is very dense, it may be best to split the area into smaller plots and blow the material into several small piles rather than one large one. As the area being cleaned becomes smaller, reduce the engine speed to prevent blowing the collected debris into the area already cleaned.

7. Check engine oil level every time engine is refueled.

WARNING: When refueling, care should be taken not to spill fuel on hot engine. This could cause the fuel to ignite, resulting in serious injury to operator or damage to unit.

8. **KEEP ENGINE CLEAN.**

Refer to Engine Manufacturer's Service Manual. Careful attention to care of air cleaner and crankcase lubrication instructions will insure longer engine life.

NOTE: FAILURE TO OBSERVE SAFETY INSTRUCTIONS MAY RESULT IN SERIOUS INJURY

UNIT ASSEMBLY HT-8950

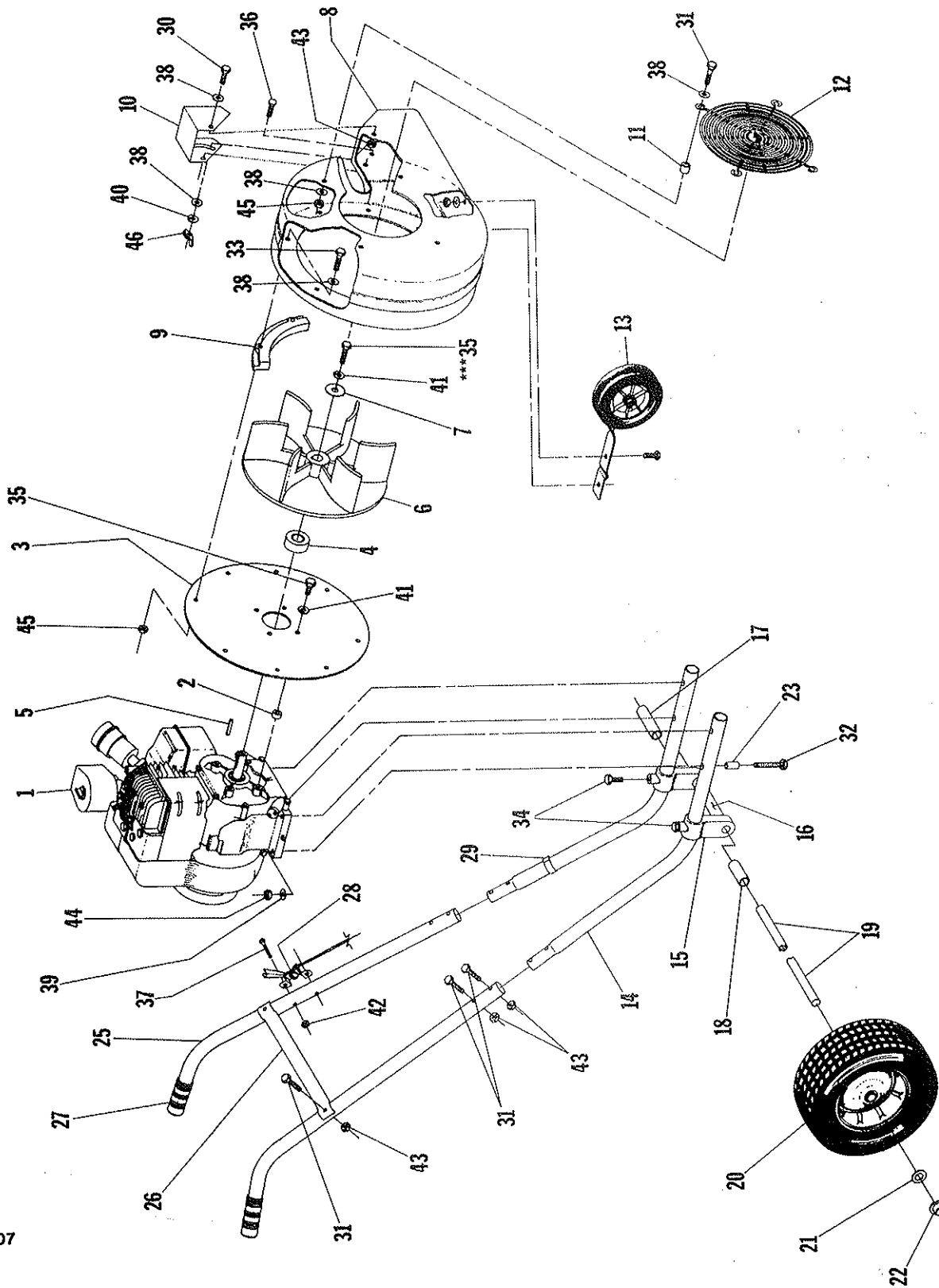

AF-907

UNIT ASSEMBLY HT-8950

PARTS LIST

Ref. No.	Part No.	Qty. Per Unit	Description
1	*	1	Engine, 5 H.P. B&S
2	83-181-A	4	Spacer
3	89-40-C	1	Back Cover
4	84-186-A	1	Fan Spacer
5	61-65-A	1	Engine Key
6	87-147-D	1	Fan Wheel
7	82-138-B1	1	Special Washer
8	82-117-D1	1	Blower Housing
9	73-123-C	4	Anti-Wrap Segment
10	82-130-C	1	Exhaust Deflector
11	82-142-A	4	Spacer
12	82-121-C	1	Grille
13	SA-1478-D	1	Wheel Arm Assembly
	**	2	• Bolt, Hex Hd. 1/4-20x1
	**	1	• Bolt, Hex Hd. 3/8-16x2 1/2
	**	3	• Flatwasher, Plain 3/8
	**	2	• Flatwasher, Plain (Wide) 1/4
	**	2	• Nut, Hex Lock 1/4-20
	**	1	• Nut, Hex Lock 3/8-16
14	86-120-D	2	Lower Handle
15	89-39-B	2	Support
16	86-118-A550	1	Axle Spacer
17	86-118-A375	1	Axle Spacer
18	86-118-A200	1	Axle Spacer
19	86-119-B	1	Axle
20	84-137-C	2	Wheel
21	55-161-A	2	Special Washer
22	86-121-A	2	End Cap
23	80-238-A	4	Insert
24	80-321-C	1	Upper Handle R.H.
25	83-18-C	1	Upper Handle, L.H.
26	86-160-C	1	Cross Brace
27	80-232-A	2	Handle Grip
28	83-25-B30	1	Throttle Control
29	80-276-A	1	Clamp, Snap-on

Items listed below should be purchased through a local Hardware, Lumber or Auto supply store. Grade 5 is recommended.

30		2	Bolt, Hex Hd. 1/4-20x3/4
31		10	Bolt, Hex Hd. 1/4-20x1 1/2
32		4	Bolt, Hex Hd. 5/16-18x2 1/2
33	67-416-20	8	Bolt, Hex Hd. (Full Thread) 1/4-20x1 1/4
34	67-616-32	2	Bolt, Hex Hd. (Full Thread) 3/8-16x2
35	60-516-16	5	Bolt, Hex Hd. 5/16-24x1
36	70-416-12	1	Bolt Carriage 1/4-20x3/4
37		2	Screw, Rd. Hd. Mach. #10-24x1 1/4
38		19	Flatwasher, Plain 1/4
39		4	Flatwasher, Plain 5/16
40		1	Lockwasher, Spring 1/4
41		5	Lockwasher, Spring 5/16
42		2	Nut, Hex Lock #10-24
43		8	Nut, Hex Lock 1/4-20
44		4	Nut, Hex Lock 5/16-18
45	346-416	12	Nut, Hex Lock (Thin) 1/4-20
46	351-416-18	1	Wing Nut

*Briggs & Stratton model no. 130212 type 3120 trim 01

**Supplied with item 13, if needed separately, purchase through a local Hardware, Lumber or Auto supply store. Grade 5 is recommended.

HT-8950 S/N 148935

then 148999 have B+S

I/C Engine # 8546-D

B/S #132412, type 0222, Trim 01