



Electronic Service Manuals

This electronic document is provided as a service to our customers. We do not create the contents of the information contained in this document. Should you have detailed questions pertaining to the information contained in this document, you may contact Michco, or the manufacturer which provided the original information in this electronic deliverable. Michco's only part in this electronic deliverable was the electronic assembly process.

You may contact Michco through the following methods:
Phone (517) 484-9312 or (800) 331-3339 MI, OH, IN only
2011 N. High St. -- Lansing, Michigan -- 48906
Fax: (517) 484-9836
Email: CustServ@Michco.com
Web site: www.Michco.Com
Parts Web site: www.FloorMachineParts.Com

Order Parts on Line at:
www.FloorMachineParts.Com

Directly to Parts & Service:
By Email: **Shop@Michco.com**
By Fax: (517) 702-2041
By Voice: Use numbers above.

Serving the Cleaning Industry Since 1922

Notice: All copyrighted material remains property of original owners, all trademarks are property of respective owners. Manuals are subject to Manufacturer's reproduction limitations. Originals or reproductions were provided by manufacturers through a request. We make no warranty as to the correctness of information provided in this document and you assume all risk.

WET/DRY VACUUMS

PV-12

PV-18

PV-18S

PV-18D

Gulper 12P

Gulper 18P

Gulper 18PS

Gulper 18PD

INTRODUCTION

OPERATING & MAINTENANCE INSTRUCTIONS

READ THIS BOOK

This operator's book has important information for the use and safe operation of this machine. Read this book carefully before starting the machine. Keep this book and tell all operators to read the book. If you do not follow the instructions, you can cause an injury or damage equipment, furniture or buildings.

For new books write to:

Pacific
2259 S. Sheridan
Muskegon, MI 49442-6252

Carefully inspect all components to ensure that there is no concealed freight damage. If such damage is discovered, file a "CONCEALED DAMAGE REPORT" immediately with the delivering carrier.

The contents of this manual are based on the latest product information available at the time of publication. Pacific reserves the right to make changes or improvements to its machines without notice.

FOR YOUR CONVENIENCE, RECORD THE FOLLOWING INFORMATION:

MODEL _____

SERIAL NUMBER _____

PART NUMBER _____

DATE PURCHASED _____

IMPORTANT SAFETY INSTRUCTIONS

READ AND UNDERSTAND ALL WARNINGS AND INSTRUCTIONS BEFORE USING THIS MACHINE!

WARNING! To reduce the risk of fire, electric shock, or injury:

1. You must be trained to operate this machine. This machine is to be operated for its intended use only.
2. Do not operate this machine unless it is completely assembled.
3. Always use a three-wire electrical system connected to the electrical ground. For maximum protection against electrical shock, use a circuit that is protected by a ground fault circuit interrupter. Consult your electrical contractor.
4. To prevent electrical shock: Always remove the electrical plug from the electrical outlet before performing any repairs, maintenance or cleanup and when leaving the machine unattended.
5. To prevent electrical shock: Keep the machine surface dry; Do not subject to rain; Store the machine in a dry building area; Clean the machine with a dry cloth only.
6. Machines can cause an explosion when near flammable materials and vapors. Do not use or store this machine with or near fuels, grain dust, solvents, thinners, or other flammable materials. Do not use flammables to clean this machine.
7. Maintenance and repairs must be done by a qualified or authorized person.
8. If the machine is not working as it should, has been dropped, damaged, left outdoors, or dropped into water, return it to a service center.
9. To avoid damage to the machine's electrical cord, always lift the machine over the cord. Do not run the machine over the electrical cord.
10. Make sure all labels, decals, warnings, cautions and instructions are fastened to the machine.

Grounding Instructions

This machine must be grounded. If it should malfunction or break down, grounding provides a path of least resistance for electric current to reduce the risk of electric shock. This machine is equipped with a cord having an equipment-grounding conductor and grounding plug. The plug must be inserted into an appropriate outlet that is properly installed and grounded in accordance with all local codes and ordinances.

WARNING - Improper connection of the equipment-grounding conductor can result in a risk of electric shock. Check with a qualified electrician or service person if you are in doubt as to whether the outlet is properly grounded. Do not modify the plug provided with the machine - if it will not fit the outlet, have a proper outlet installed by a qualified electrician.

This machine is for use on a nominal 120-volt circuit, and has a grounded plug that looks like the plug illustrated in figure A. A temporary adapter that looks like the adapter illustrated in figures B and C may be used to connect this plug to a 2-pole receptacle as shown in figure B if a properly grounded outlet is not available. The temporary adapter should be used only until a properly grounded outlet (figure A) can be installed by a qualified electrician. The green colored rigid ear, lug, or the like extending from the adapter must be connected to a permanent ground such as a properly grounded outlet box cover. Whenever the adapter is used, it must be held in place by a metal screw.

NOTE: In Canada, the use of a temporary adapter is not permitted by the Canadian Electrical Code

EXTENSION CORDS

Use only three-wire 16/3 or larger gauge approved extension cords that have three-prong grounding type plugs and three-pole receptacles that accept the appliance's plug. Replace or repair any damaged cords or plugs.

When servicing, refer to authorized person only. Use only identical replacement parts.

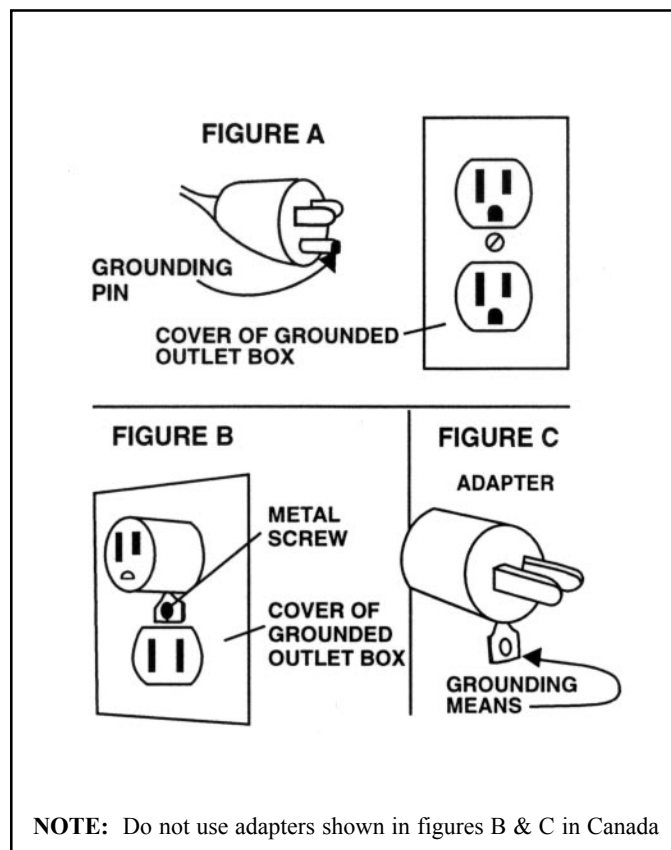

OPERATING PROCEDURES

WARNING! For the safe operation of this machine follow the instructions given in this booklet and the training given by your supervisor. Failure to do so can result in personal injury and/or damage to machine and property!

DO NOT OPERATE MACHINE IN AN EXPLOSIVE ENVIRONMENT!

WARNING! NEVER USE THIS MACHINE TO PICK UP VOLATILE OR EXPLOSIVE MATERIALS.

OPERATION

To prepare the machine for operation, make sure it is of the correct voltage and properly assembled. If in doubt, ask your supervisor.

FOR DRY PICK-UP:

“Dry” refers to material such as dust, dirt, debris and dry foam shampoo.

1. Release the clamp on the side of the tank and head assembly. Lift the head assembly off and set it aside.
2. Then lift the cloth filter assembly out of the collector tank. Clean the cloth filter if needed (reference the “Maintenance” section).
3. Empty the collector tank of all dust and debris. If the debris is wet, empty and dry the inside of the tank thoroughly.
4. Place the cloth filter assembly back into the collector tank. Check for a good seal around the outer filter lip and tank rim.
5. Replace the head assembly and fasten the clamp. Attach the hose, wand and floor tool of choice (reference page 5).
6. Plug the power cord into a 115-volt, 60 cycle grounded outlet.
7. Turn the machine’s motor on by pressing the rocker switch which is located on the head assembly.

FOR WET PICK-UP:

“Wet” refers to liquids such as water, scrub solutions and detergents; **NOT** volatile or explosive materials.

1. Release the clamp on the side of the tank and head assembly. Lift the head assembly off and set it aside.
2. Then lift the cloth filter assembly out of the collector tank. Store the filter assembly for future, dry pick-up use. **DO NOT REINSTALL.**
3. Empty the collector tank of all dust and debris. Also wipe the inside of the collector tank to remove clinging dust.
4. Check the float shut-off device on the lower portion of the head assembly. The float should have free movement. When the recovered liquid soilage reaches the collector tank capacity, the float will rise to shut off the air flow, stopping the liquid recovery. This prevents damaging overflow and signals the operator when to empty the collector tank.
5. Replace the head assembly and fasten the clamp. Attach the hose, wand and floor tool of choice (reference page 5).
6. Plug the power cord into a 115-volt, 60 cycle grounded outlet.
7. Turn the machine’s motor on by pressing the rocker switch which is located on the head assembly.

ACCESSORIES

Tool Kit #608809 is included with the Models PV-12/12P, PV-18/18P and PV-18D/18PD. **See Page 5 for the kit’s illustration and assembly instructions.**

The **Front Mounted Squeegee #608521** is included with the Model 18PS. **Reference Pages 10 and 11 for the squeegee’s illustration and assembly instructions.**

The tool kit and front mounted squeegee are also available as optional accessories.

MAINTENANCE

Good maintenance procedures assure better operation, fewer repairs and longer life to your machine.

DISCONNECT THE ELECTRICAL PLUG OF THE MACHINE FROM THE ELECTRICAL OUTLET BEFORE DOING ANY CLEANUP, REPAIRS OR MAINTENANCE OF THE MACHINE AND WHEN LEAVING THE MACHINE UNATTENDED.

CLEAN THE MACHINE AFTER EACH USE:

1. **Wipe the outside with a clean cloth.**
2. **Clean the collector tank:** Release the clamps on each side of the tank and head assembly. Lift the head assembly off and set aside. Lift the filter assembly out of the collector tank and set aside. Then wipe the inside of the collector tank with a clean cloth.
3. **Empty and check the filter assembly:** Empty the recovered soilage into a suitable container and shake to remove clinging dirt. Brush the outside of the filter bag to remove embedded dirt. Check the filter assembly for tears or holes; repair or replace if necessary. Install the clean filter assembly into the clean collector tank.

ELECTRICAL CABLE:

Check the cord for any nicks, cuts or damage. Report these to your supervisor for correction.

VACUUM HEAD ASSEMBLY:

1. **Gaskets:** Clean the vacuum head gasket (23) and the float shut-off gasket (24 on page 6).
2. **Float Shut-Off Device:** This should move freely. Remove any debris or strings from the float cage.
3. **Head Assembly:** Replace and leave ajar if the collector tank is damp to prevent mildew.

WHEELS AND CASTERS:

Check these for cuts and nicks. Remove any strings or debris that may restrict the free movement of the wheels. Wipe the treads clean.

CARBON BRUSH INSPECTION:

Check for wear at six month intervals or every 600 hours of operation. The carbon brushes must be replaced if worn shorter than 3/8 inch.

TOOL KIT PART #608809

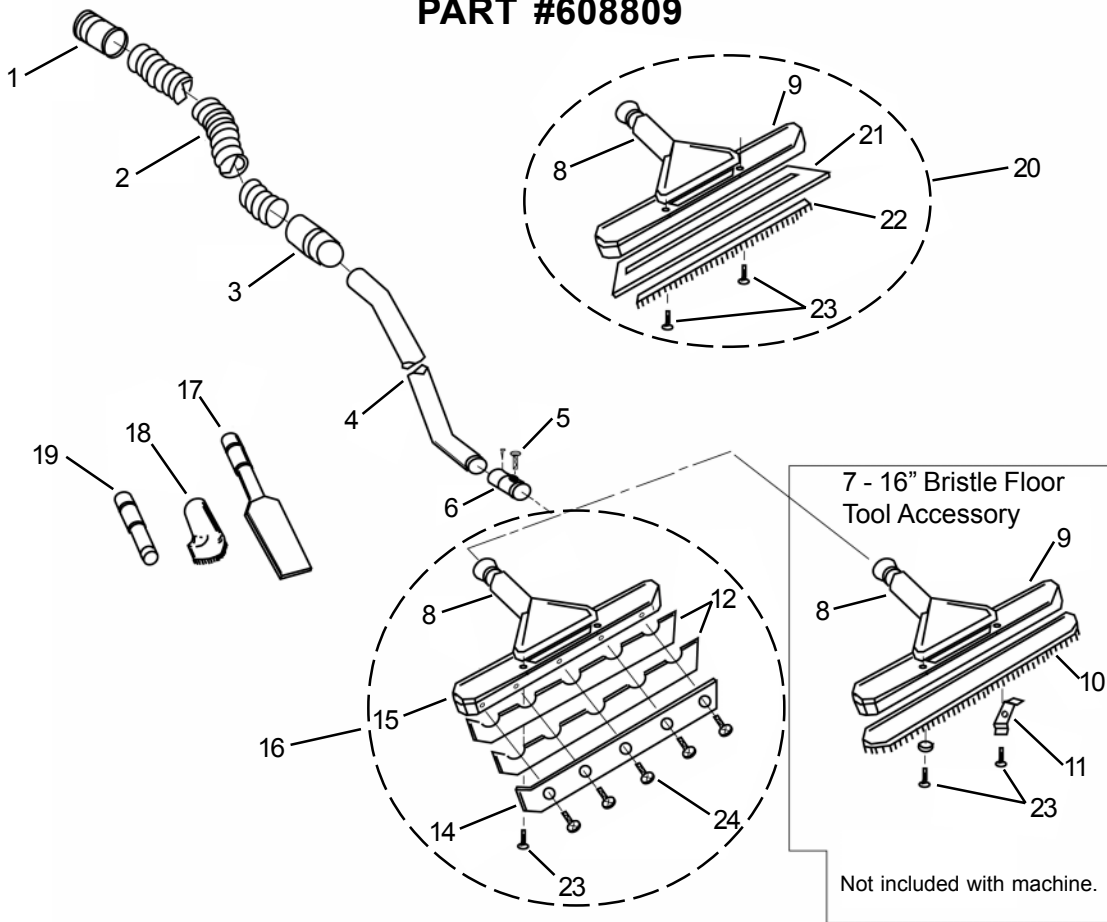

ITEM	PART NO.	DESCRIPTION	QTY.
1	600206	Adaptor, 1-1/2 Hose, Vac End	1
2	604108	Hose, 1-1/2x10ft. (w/out adaptors)	1
	604114	Hose Asm, 1-1/2x10ft. (w/adaptors)	1
3	600205	Adaptor, 1-1/2 Hose, Wand End	1
4	609810	Wand Asm., with Adaptor & Pin	1
	609813	Wand Half w/out Adaptor (top half)	
	609809	Wand Half w/Adaptor & Pin (bottom half)	
5	606710	Disconnect Pin Assembly	1
6	600204	Adaptor, Wand	1
7	608810	16" Bristle Floor Tool Asm.-Optional	
8	601803	Top Casting with Adaptor	1
9	601804	Base Casting, Bristle Tool	1
10	600901	Brush, Bristle Tool	1
11	602011	Clamp, Brush	2
12	600701	Blade, Squeegee Pickup	2
14	607212	Retainer	2
15	601802	Base Casting-Squeegee Tool	1
16	608812	16" Squeegee Floor Tool Asm.	1
17	608816	1-1/2" Crevice Tool	1
18	608820	3" Round Dusting Tool	1
19	600210	Tool Adaptor, 1-1/4 to 1-1/2	1
20	608811	16" Carpet Tool Asm.	1
21	607901	Carpet Shoe	1
22	600902	Brush Strip	1
23	964022	Screw	6
24	962115	10-24x3/8 Self-Tapping Screw	5

TOOL KIT ASSEMBLY:

1. Connect the hose to the collector tank by inserting the large, grooved hose adapter end into the tank adapter. Press the pawl (#35 on Wet/Dry Vac) to allow the hose adapter to slide further in. Release the pawl to engage the large groove.
2. Insert the upper wand half firmly into the lower wand assembly. The dimple on the lower wand aligns with the groove of the upper half to assure a rigid fit.
3. Insert the wand end into the free end of the vacuum hose. Then fasten the proper floor tool to the wand by inserting the mating end of the floor tool into the adapter collar of the wand assembly. Pull the tool locking pin to allow total engagement of the adapter and tool. Release the pin to lock the tool to the wand.
4. The hand tools may also be used by inserting their adapter directly into the free end of the vacuum hose.
5. Tool Selection: Choosing the proper tool will give the best results. To vacuum dust and debris from floors or walls-select the bristle floor tool. To remove water, liquid waste, strip solution, etc. from hard surfaced floors-use the squeegee floor tool. When vacuuming carpets or rugs-choose the carpet tool.

PV-12 & PV-18
GULPER 12P & 18P

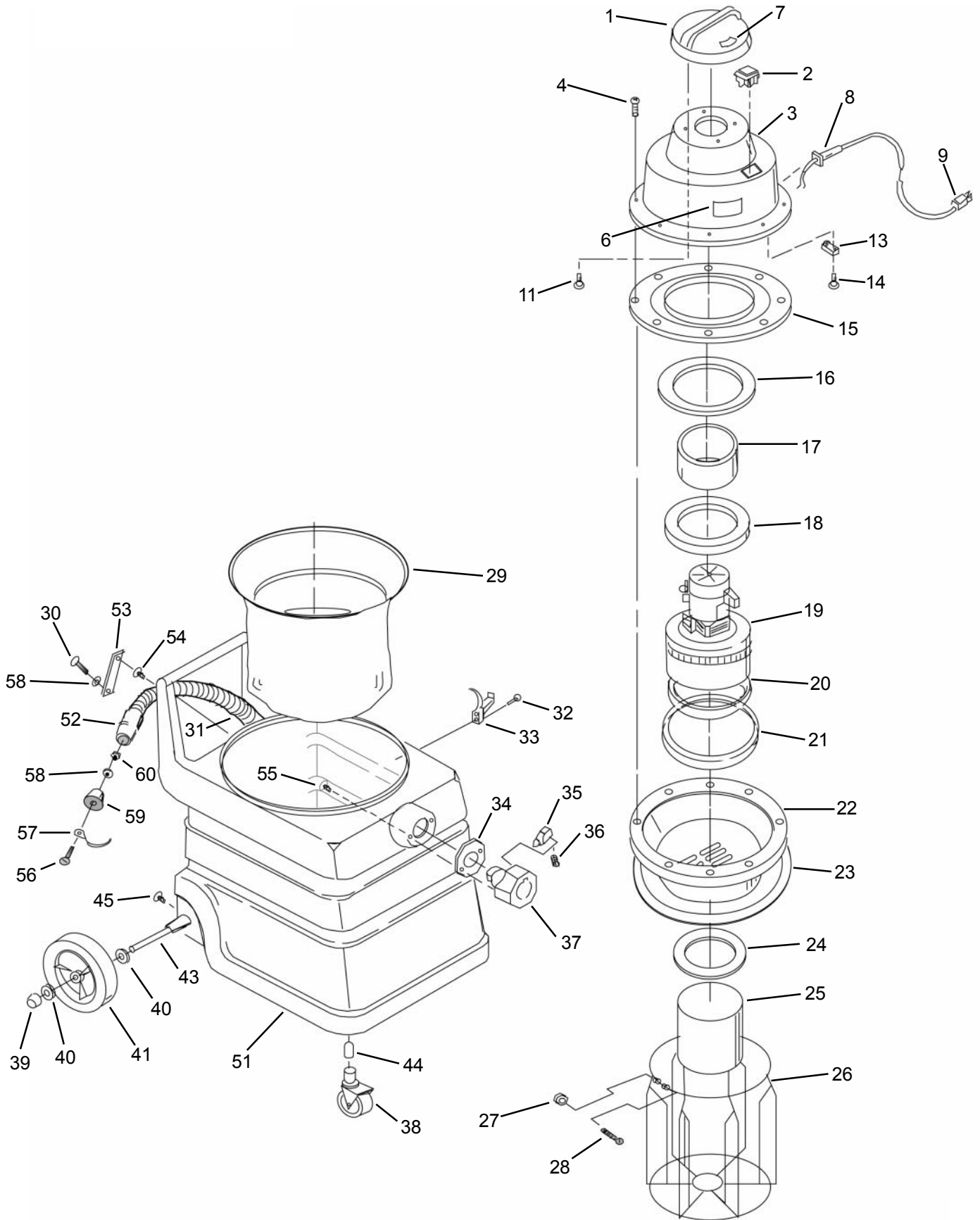

**PV-12 & PV-18
GULPER 12P & 18P**

ITEM	PART NO.	DESCRIPTION	QTY.
1	601540	Cap	1
2	608010	Switch	1
3	602340	Cover, Motor	1
4	964022	Screw, Motor Cover	8
6		Serial Plate	1
7	515150	Warning Label	1
8	608530	Strain Relief	1
9	908010	Power Cord, 16-3x35ft. - PV-12/12P	1
	908034	Power Cord, 16-3x35 ft.- PV-18/18P	1
11	964020	Screw, Cap	4
13	607210	Retainer, Cord	1
14	964021	Screw, Retainer	4
15	600214	Adaptor, Upper Motor	1
16	600216	Adaptor, Middle	1
17	602771	Filter, Air Vent	1
18	603473	Gasket, Upper Mtr (Use two for service)	2
19	605210	Motor, 1.2HP, 115V	1
	605211	Motor, 1.2HP, 230V, 2 Stage	1
	600903	Brush, Carbon for 605210 & 605211	2
20	603410	Gasket, Lower Motor	1
21	603421	Gasket, cut to length	1
22	600215	Adaptor, Lower Motor	1
23	603442	Gasket, Lower Adaptor	1
24	603412	Gasket, Float Shut Off	1
25	603312	Float-Shut Off	1
26	602413	Cage	1
27	W106D	Nut	1
28	962120	Screw	1
29	600530	Filter Bag Asm.	1
30	962015	Screw	2
31	602012	Clamp, Hose (where hose exits tank)	1
32	930005	Pop Rivet	4
33	605101	Latch	2
34	603415	Gasket, Plastic Cover	1
	603425	Gasket, Foam Adaptor	1
35	607001	Pawl	1
36	608303	Spring	1
37	602415	Coupler Asm, Tank	1
38	619701	Caster, 3" Dia.	2
39	S482P	Snap Axle Cap	2
40	509820	Washer	4
41	609758	Wheel	2
43	607712	Shaft, Wheel: PV-12/12P	1
	607711	Shaft, Wheel: PV-18/18P	1
44	604650	Insert, Caster	2
45	962109	Screw	1
51	608670	Tank, PV-12/12P	1
	608672	Tank, PV-18/18P	1
52	604107	Hose, Drain	1
53	608508	Strap	2
54	603313	Fastener	2
55	962112	Screw	2
56	962113	Screw	1
57	602408	Stretch Cord	1
58	W105D	Washer	1
59	608504	Stopper	1
60	920017	Nut	1

**PV-18S & PV-18D
GULPER 18PS & 18PD**

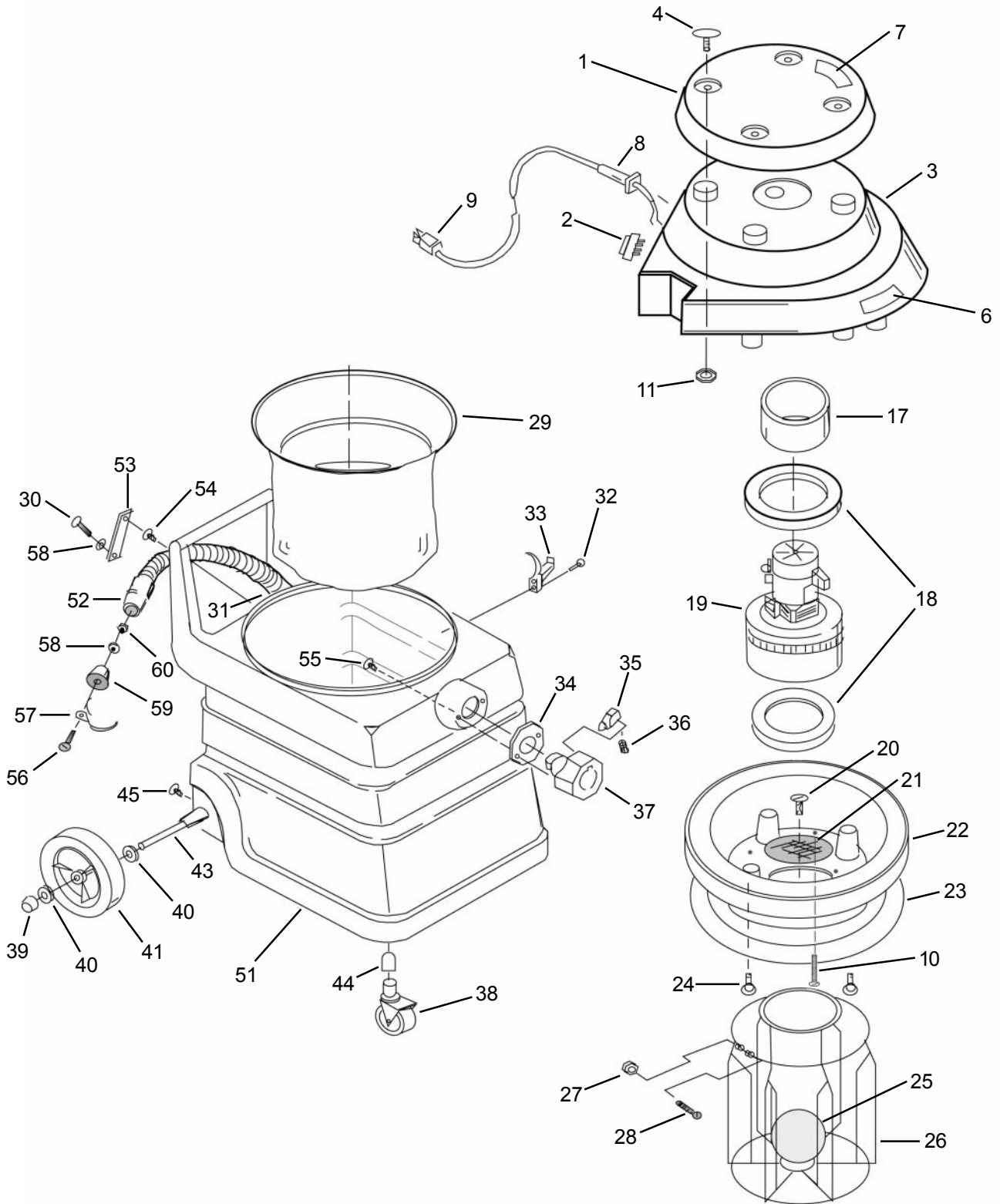

**PV-18S & PV-18D
GULPER 18PS & 18PD**

ITEM	PART NO.	DESCRIPTION	QTY.
1	602370	Cap	1
2	911089	Switch	1
3	602770	Cover, Motor	1
4	960030	Screw, Motor Cover	4
6		Serial Plate	1
7	515150	Warning Label	1
8	608530	Strain Relief	1
9	908012	Power Cord, 16-3x50ft. - PV-18S/18PS	1
	908034	Power Cord, 16-3x35 ft.- PV-18D/18PD	1
10	W131D	Screw, 1/4-20x5 HH	4
11	W148D	Nut, Cap	4
17	602771	Filter, Air Vent	1
18	603473	Gasket, Motor	2
19	605213	Motor, 1.2HP, 115V, 3 Stage	1
	200951	Brush, Carbon	2
20	W136D1	Screw, Screen	4
21	608570	Screen	1
22	600272	Adaptor, Tank Head	1
23	603472	Gasket, Head	1
24	962003	Screw	4
25	603370	Float-Ball	1
26	602471	Cage	1
27	W106D	Nut	1
28	962120	Screw	1
29	600670	Filter Bag Asm.	1
30	962015	Screw	2
31	602012	Clamp, Hose (located where hose exits tank)	1
32	930005	Pop Rivet	4
33	605101	Latch	2
34	603415	Gasket, Plastic Cover	1
	603425	Gasket, Foam Adaptor	1
35	607001	Pawl	1
36	608303	Spring	1
37	602415	Coupler Asm, Tank	1
38	619701	Caster, 3" Dia.	2
39	S482P	Snap Axle Cap	2
40	509820	Washer	4
41	609758	Wheel	2
43	607711	Shaft, Wheel	1
44	604650	Insert, Caster	2
45	962109	Screw	1
51	608672	Tank	1
52	604107	Hose, Drain	1
53	608508	Strap	2
54	603313	Fastener	2
55	962112	Screw	2
56	962113	Screw	1
57	602408	Stretch Cord	1
58	W105D	Washer	2
59	608504	Stopper	1
60	920017	Nut	1

SQUEEGEE ASSEMBLY PART #608521

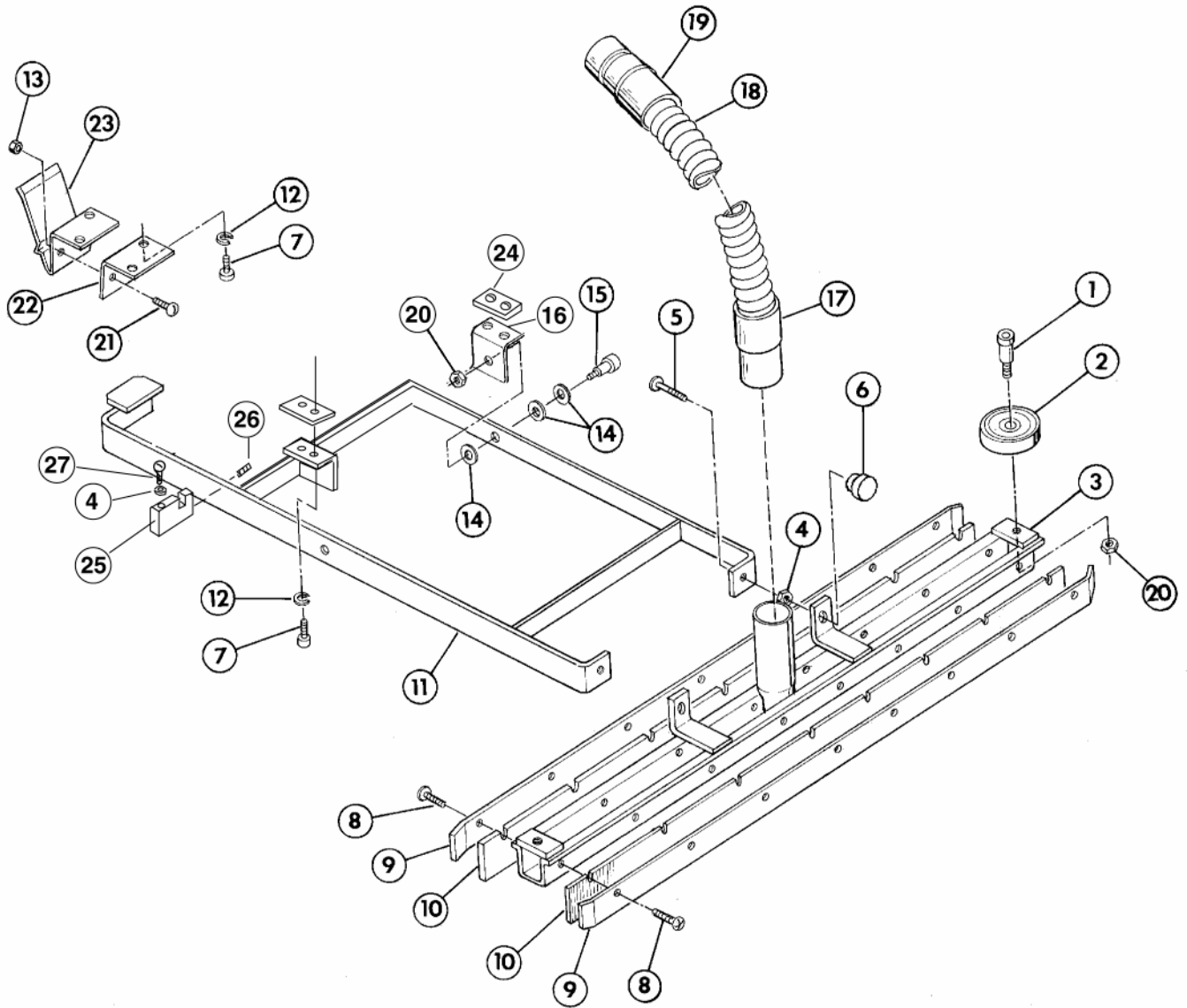

SQUEEGEE ASSEMBLY PART #608521

ITEM	PART NO.	DESCRIPTION	QTY.
1	960008	Bolt, Shoulder	2
2	609703	Wheel	2
3	608506	Squeegee Channel Weldment	1
4	920019	Nut, 1/4-20 Hex Jam	3
5	W189D	Screw, 14-20x3/4 HH CS	2
6	A13018	Knob	2
7	W506D	Screw, 5/16-18x3/4 HH MS	6
8	W380D	Screw, 10-32x3/4 PHP	16
9	607209	Retainer-Squeegee Blade	2
10	600705	Blade, 28" Squeegee	2
11	600301	Arm Weldment-Squeegee	1
12	980006	Washer, 5/16 Lock	6
13	920001	Nut, 10-32 Elastic Stop	2
14	980007	Washer, 5/16 Flat	6

ITEM	PART NO.	DESCRIPTION	QTY.
15	960007	Bolt, Shoulder, 3/8x1/2 Lg	2
16	600806	Bracket, Arm Support	2
17	600205	Adaptor, Hose	1
18	604106	Hose, Vacuum	1
19	600206	Adaptor, Hose	1
20	920012	Nut, 5/16-18 ESNA Lock	4
21	962015	Screw, 10-32x3/8 Pan Hd	2
22	608507	Support, Lock Backup	1
23	605102	Lock, Squeegee Spring	1
24	608201	Spacer, Squeegee Support	2
25	608512	Stop, Squeegee Arm	1
26	W168D	Screw, Set	1
27	962010	Screw, 1/4-20x1 HHCS	1

MOUNTING INSTRUCTIONS

For the Models PV-18S/Gulper 18PS which include the Squeegee Assembly:

1. Position the machine on a level surface.
2. Unlock the lower squeegee lift arm weldment (11).
3. Align the squeegee with the lift arm weldment; using the shoulder screws (5) on the back side of the lift arm weldment, place the jam nuts (4) between the arm weldment and squeegee and then screw the knobs (6) on the front of the squeegee assembly. Leave the hardware slightly loose.
4. Position the squeegee assembly to assure that it sits flat from side to side level with the surface. Then tighten the knobs.
5. Connect the vacuum hose assembly, Items 17, 18 and 19 to the tank adaptor and squeegee adaptor.
6. Adjust the squeegee height by rotating the screw (27) clockwise to lower the squeegee and counterclockwise to raise the squeegee.

Squeegee Assembly as an Accessory - for the Models PV-12/Gulper 12P, PV-18/Gulper 18P and PV-18D/Gulper 18PD:

1. Remove the head assembly and the filter bag assembly.
2. Turn the machine upside down.
3. Mount the arm support brackets (16) to the inner surface of the squeegee lift arm weldment (11) using the shoulder screws (15), flat washers (14) and jam nut (20). Reference the illustration - two washers are on the outside of the lift arm weldment and one washer is between the support bracket and squeegee lift arm weldment. Tighten the hardware and check for free rotation. If needed, slightly loosen the jam nut.
4. Mount the squeegee arm stop (25) to the lift arm weldment (11) using the set screw (26). Then assemble the screw (27) and nut (4) to the stop (25) as illustrated.
5. Position this assembly on the bottom of the tank with the foot pedal to the rear of the tank, facing down.
6. Attach the arm support brackets (16) and the spacers (24) to the tank with the bolt (7) and washer (12).
7. Assemble the lock backup support (22) to the lock spring (23) with the screw (21) and nut (13) keeping the edges flush.
8. Attach the spring lock assembly (22&23) to the bottom of the tank using the bolt (7) and washer (12).
9. With the spring lock pressed in against the tank, check that the pedal clears the spring lock. Loosen the bolt (7) to adjust the spring lock assembly (22&23) location.
10. Turn the machine upright.
11. Proceed with steps 1-4 from the previous section.
12. If using on a PV-12/12P remove the adaptor (17) and cut the hose assembly (18&19) to a 16 inch length. The 16 inches includes the adaptor (19). Do not cut the hose assembly for the PV-18/18P and PV-18D/18PD.
13. Screw adaptor (17) onto the hose assembly.
14. Connect the vacuum hose assembly, Items 17, 18 and 19 to the tank adaptor and squeegee adaptor.
15. Adjust the squeegee height by rotating the screw (27) clockwise to lower the squeegee and counterclockwise to raise the squeegee.
16. Replace the head assembly and filter bag assembly.

WARRANTY POLICY POLYETHYLENE WET/DRY VACUUMS

The **Pacific** Wet/Dry Vacuum has been manufactured, tested and inspected in accordance with specific engineering requirements and is WARRANTED to be free from defects in workmanship and materials as follows:

Five (5) Years Parts, One (1) Year Labor - Polyethylene Components
One (1) Year Parts and Labor - All other components unless excluded below.

This warranty extends to the original user/purchaser and only when used, operated and maintained in accordance with **Pacific** Operating and Maintenance instructions.

This warranty does not apply to certain wear parts and accessories of the machine such as electrical cords, carbon motor brushes, floor brushes, squeegee blades, hoses, tools, filters, casters, wheels, etc. Nor does it apply to damage or failure caused by improper use, abuse or neglect. Warranty credit or replacement of return parts including motors, etc., is subject to incoming inspection of those items.

To secure repair under this warranty, the following procedure should be taken:

- The inoperative machine or warranted parts must be delivered to the authorized dealer with shipping and delivery charges prepaid. If unable to locate the Dealer, you may contact **Pacific** at the address listed herein for the location of the nearest **Pacific** repair center or agent or for other instructions pertaining to your warranty difficulty.
- Upon compliance with the above warranty procedure, all warranted repairs would be completed at no additional charge or cost to the user.
- Only **Pacific** or its authorized dealers and agents may make no charge warranty repairs on this product. All others do so at their own risk.

This warranty limits **Pacific's** liability to the repair of the product and/or warranted parts replacement and does not include incidental or consequential damages arising from the use of a **Pacific** machine whether defective or not.

This warranty is in lieu of all other expressed or implied warranties and is extended to the original purchaser/user.

PACIFIC

2259 Sheridan
Muskegon, Michigan 49442
Ph: (800) 968-1332 Fax: (231) 773-1642

www.nextwaveofclean.com