



Electronic Service Manuals

This electronic document is provided as a service to our customers. We do not create the contents of the information contained in this document. Should you have detailed questions pertaining to the information contained in this document, you may contact Michco, or the manufacturer which provided the original information in this electronic deliverable. Michco's only part in this electronic deliverable was the electronic assembly process.

You may contact Michco through the following methods:
Phone (517) 484-9312 or (800) 331-3339 MI, OH, IN only
2011 N. High St. -- Lansing, Michigan -- 48906
Fax: (517) 484-9836
Email: CustServ@Michco.com
Web site: www.Michco.Com
Parts Web site: www.FloorMachineParts.Com

Order Parts on Line at:
www.FloorMachineParts.Com

Directly to Parts & Service:
By Email: **Shop@Michco.com**
By Fax: (517) 702-2041
By Voice: Use numbers above.

Serving the Cleaning Industry Since 1922

Notice: All copyrighted material remains property of original owners, all trademarks are property of respective owners. Manuals are subject to Manufacturer's reproduction limitations. Originals or reproductions were provided by manufacturers through a request. We make no warranty as to the correctness of information provided in this document and you assume all risk.

Manual Powered Sweepers

MINISWEEP MAXISWEEP and CLEANBOY

INTRODUCTION

OPERATING & MAINTENANCE INSTRUCTIONS

READ THIS BOOK

This operator's book has important information for the use and safe operation of this machine. Read this book carefully before starting the machine. Keep this book and tell all operators to read the book. If you do not follow the instructions, you can cause an injury or damage equipment, furniture or buildings.

For new books write to:

Pacific
2259 S. Sheridan
Muskegon, MI 49442-6252

Carefully inspect all components to ensure that there is no concealed freight damage. If such damage is discovered, file a "CONCEALED DAMAGE REPORT" immediately with the delivering carrier.

The contents of this manual are based on the latest product information available at the time of publication. Pacific Steamex reserves the right to make changes or improvements to its machines without notice.

**FOR YOUR CONVENIENCE, RECORD THE
FOLLOWING IMPORTANT INFORMATION:**

MODEL _____
SERIAL NUMBER _____
PART NUMBER _____
DATE PURCHASED _____

OPERATION

Introduction

These manual operated sweepers are designed with two counter rotating brushes that can pick up small and large debris on hard, flat surfaces. The sweepers will pick up paper, leaves and general litter – both inside and out. However they are not designed for dust. The debris is swept into the hopper and the hopper is easily removed by lifting the handle; then the hopper can be carried separately for disposal of the debris.

Assembly

Your sweeper requires little assembly before operation. Follow these simple steps:

1. **Secure the front cover to the hopper.** Fit them together by placing the two bottom corners of the hopper to the locating lugs on the corners of the front cover. After these are fitted together, the hopper's handle (Item 21) can be pushed down - this latches the front cover and hopper together.
2. **Assemble the operator's handle.** The machine handle is shipped in three parts: the "U" shaped tube and the two straight lower tubes.
 - a) First connect each straight tube to the U tube. Depress the spring clip on the straight tube and slide it into the U tube until it clicks into the chosen hole. The handle height is adjusted by selecting either the top or bottom pair of holes.
 - b) Connect the handle assembly to the machine. Unscrew the clamping knobs (Item 2) from each side of the machine. The handle tubes will fit over the exposed screws. Then screw the knobs back on.

Operation

This sweeper can be used for both indoor and outdoor sweeping.

DO NOT PICK UP ANYTHING THAT IS BURNING OR SMOKING, SUCH AS CIGARETTES, MATCHES OR HOT ASHES.

1. Make sure the hopper and front cover are **securely fastened** (reference Assembly #1).
2. Adjust the **handle height** for the operator (reference Assembly #2).
3. Adjust the **brush pressure** to accommodate your pick up needs. The height adjustment dial (Item # 1) is located on the front of the sweeper. For larger debris use a high setting, number 1 is the highest position. Move to a higher number (lower position) for picking up finer debris. Do not press the brushes too firmly to the ground because this will eventually wear out the drive mechanism.
4. **Start sweeping.** The overlapping brushes ensure good coverage. The edge guide rollers (MiniSweep and MaxiSweep Models) on both sides enable the brushes to reach into corners. Dirt and debris will be pushed into the hopper as soon as you begin pushing the sweeper. The carrying capacity of the hopper can be increased by raising the front of the sweeper, this will move debris to the back of the hopper.
5. **Empty the hopper** when you're done sweeping. Simply pull up on the hopper's handle and lift the hopper off the front cover. Dispose of the debris in an approved waste receptacle. **Clean** the hopper if necessary. **Reattach** the hopper to the front cover.
6. To **transport** the sweeper place the handle in the down position: loosen the clamps on each side of the machine, then lower the handle toward the brushes until it slides past the molded stoppers. Retighten the clamps. Remember to loosen the clamps before raising the handle again.
7. **Storage:** Store the sweeper indoors. The sweeper may be stored in the standing or hanging position. To hang the sweeper, place the handle in the down position as described in Step 6.

MAINTENANCE

1. **Hopper:** We recommend that the hopper be emptied after each use.
2. **Clean the hopper and machine** by wiping with a dry cloth as needed.
3. **Brushes:** After each use, remove any strings or debris. See Step 5 for cleaning and replacement.
4. **Replacement or Cleaning of the Angled Wheels (D):** Set the height adjustment dial to position 8. Pull the angled wheel (D) strongly, to remove it and its axle from the tooth sleeve. Clean or replace the wheel, then push it firmly back into the tooth sleeve. Make sure you place the wheels back in their correct positions, they are marked L and R for the left and right positions.
5. **Cleaning or Replacement of the Brushes (B) and Nylon Gear Casing (C):** Remove the angled wheel (D) as explained in Step 4. Pull the brush towards you - the brush and gear will come away from the pivot housing. The gear can now be pulled away from the brush. The brushes and gears may be cleaned with water. The gears should only be lubricated with silicone spray.

Ensure that the brushes and gears are fitted on the correct side of the sweeper when reassembling. To guide you, the inside of the front cover is marked L and R, as are the wheels (D) and each brush is marked L/// and R\\ which indicates the direction of the bristle point. To reassemble, place the brush over the pivot housing then push the nylon gear (C) over the pivot housing. Refit the angled wheel.

MINISWEEP, MAXISWEEP & CLEANBOY

MiniSweep & MaxiSweep Only

CleanBoy Only

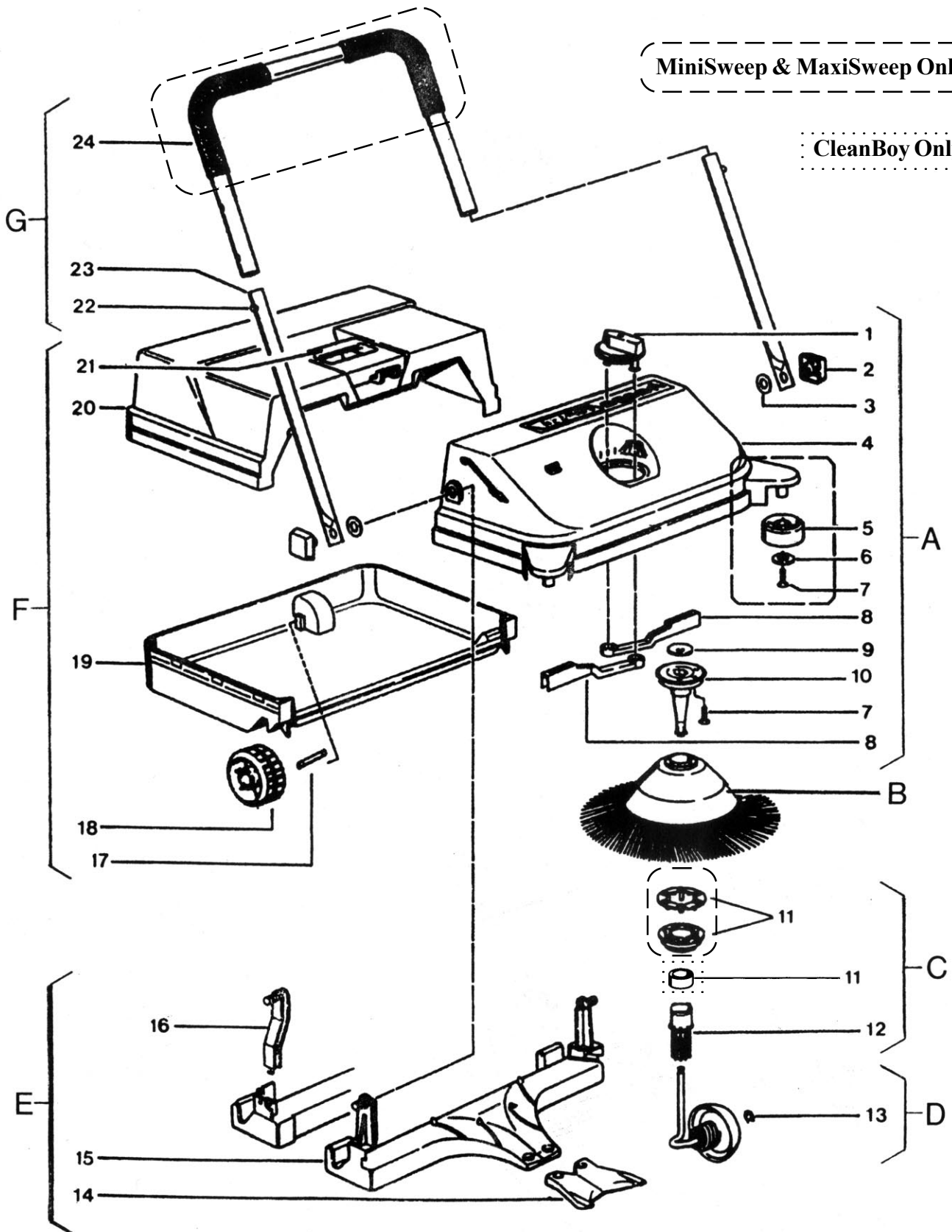

MINISWEEP, MAXISWEEP & CLEANBOY PARTS LIST

ITEM	MINISWEEP PART NUMBER	MAXISWEEP PART NUMBER	CLEANBOY PART NUMBER	DESCRIPTION	QTY
	715402	715411	715425	Machine, Complete	
A	712301	712310	712304	Front Cover Complete	
1	712701	712701	712701	Height Adjustment Dial	1
2	712001	712001	712001	Clamp	2
3	712002	712002	712002	Washer, Clamp	2
4	712302	712311	712303	Front Cover	1
5	717501	717501	NA	Edge Guiding Roller	2
6	980631	980631	NA	Washer, Edge Roller	2
7	960032	960032	NA	Screw	2
8	718501	718510	718501	Adjustment Slide	2
9	980632	980633	980632	Washer, Pivot Housing	2
10	714201	714210	714201	Pivot Housing	2
B	710901	710902	710903	Circular Brush Set, Left&Right	1
	710901L	710902L	710903L	Brush, Left	
	710901R	710902R	710903R	Brush, Right	
C	718101	718110	NA	Tooth Sleeve with Clutch Left	1
	718102	718111	NA	Tooth Sleeve with Clutch Right	1
11	712401	712410	NA	Clutch Complete, Left	
	712402	712411	NA	Clutch Complete, Right	
	NA	NA	717301	Friction Ring	2
12	713501	713502	718103	Tooth Sleeve	2
D	719701	719702	719701	Wheel Set Complete	1
	719701L	719702L	719701L	Wheel, Left	
	719701R	719702R	719701R	Wheel, Right	
13	980634	980634	980634	Washer, 6mm	
E	716601	716610	716601	Sweeping Plate with Lip	1
14	715101	715101	715101	Sweeping Lip	
15	716602	716611	716602	Sweeping Plate	
16	714001	714001	714001	Holder	
F	714501	714510	714505	Hopper Complete	1
17	717701	717701	717701	Axle	
18	719703	719704	719703	Wheel	
19	714502	714511	NA	Bottom, Hopper	
20	714503	714512	NA	Cover, Hopper	
21	713901	713901	713901	Handle, Hopper	
G	713902	713910	713906	Handle, Machine Complete	1
22	712101	712101	712101	Spring Clip	
23	719001	719001	719001	Straight Tube	
24	713903	713904	713907	U Handle Section	
	713701	713701	NA	Grips, 2 pcs./set	2

NOTES

NOTES

WARRANTY POLICY MINISWEEP, MAXISWEEP & CLEANBOY

The **Pacific** Sweeper has been manufactured, tested and inspected in accordance with specific engineering requirements and is **WARRANTED** to be free from defects in workmanship and materials as follows:

MiniSweep and MaxiSweep:

One (1) year parts & labor - All components unless excluded below.

CleanBoy:

Six (6) months parts & labor - All components unless excluded below.

This warranty does not apply to the following wear parts and accessories of the MiniSweep, MaxiSweep and CleanBoy including:
Brushes, Left and Right

This warranty extends to the original user/purchaser and only when used, operated and maintained in accordance with **Pacific** Operating and Maintenance instructions.

This warranty does not apply to certain wear parts of the machine such as the brushes, nor does it apply to damage or failure caused by improper use, abuse or neglect. Warranty credit or replacement of return parts is subject to incoming inspection of those items.

Nor does it apply to damage or failure caused by improper use, abuse or neglect. Warranty credit or replacement of return parts is subject to incoming inspection of those items.

To secure repair under this warranty, the following procedure should be taken:

- The inoperative machine or warranted parts must be delivered to the authorized dealer with shipping and delivery charges prepaid. If unable to locate the Dealer, you may contact **Pacific** at the address listed herein for the location of the nearest **Pacific** repair center or agent or for other instructions pertaining to your warranty difficulty.
- Upon compliance with the above warranty procedure, all warranted repairs would be completed at no additional charge or cost to the user.
- Only **Pacific** or its authorized dealers and agents may make no charge warranty repairs on this product. All others do so at their own risk.

This warranty limits **Pacific** liability to the repair of the product and/or warranted parts replacement and does not include incidental or consequential damages arising from the use of a **Pacific** machine whether defective or not.

This warranty is in lieu of all other expressed or implied warranties and is extended to the original purchaser/user.



PACIFIC

2259 S. Sheridan • Muskegon, MI 49442
Ph: (231) 773-1330 • (800) 968-1332 • Fax (800) 863-9536
www.pacificfloorcare.com