



Electronic Service Manuals

This electronic document is provided as a service to our customers. We do not create the contents of the information contained in this document. Should you have detailed questions pertaining to the information contained in this document, you may contact Michco, or the manufacturer which provided the original information in this electronic deliverable. Michco's only part in this electronic deliverable was the electronic assembly process.

You may contact Michco through the following methods:
Phone (517) 484-9312 or (800) 331-3339 MI, OH, IN only
2011 N. High St. -- Lansing, Michigan -- 48906
Fax: (517) 484-9836
Email: CustServ@Michco.com
Web site: www.Michco.Com
Parts Web site: www.FloorMachineParts.Com

Order Parts on Line at:
www.FloorMachineParts.Com

Directly to Parts & Service:
By Email: **Shop@Michco.com**
By Fax: (517) 702-2041
By Voice: Use numbers above.

Serving the Cleaning Industry Since 1922

Notice: All copyrighted material remains property of original owners, all trademarks are property of respective owners. Manuals are subject to Manufacturer's reproduction limitations. Originals or reproductions were provided by manufacturers through a request. We make no warranty as to the correctness of information provided in this document and you assume all risk.

PACIFIC

ScrubMaster 26R

**ELECTRICAL
MANUAL**

07/2001

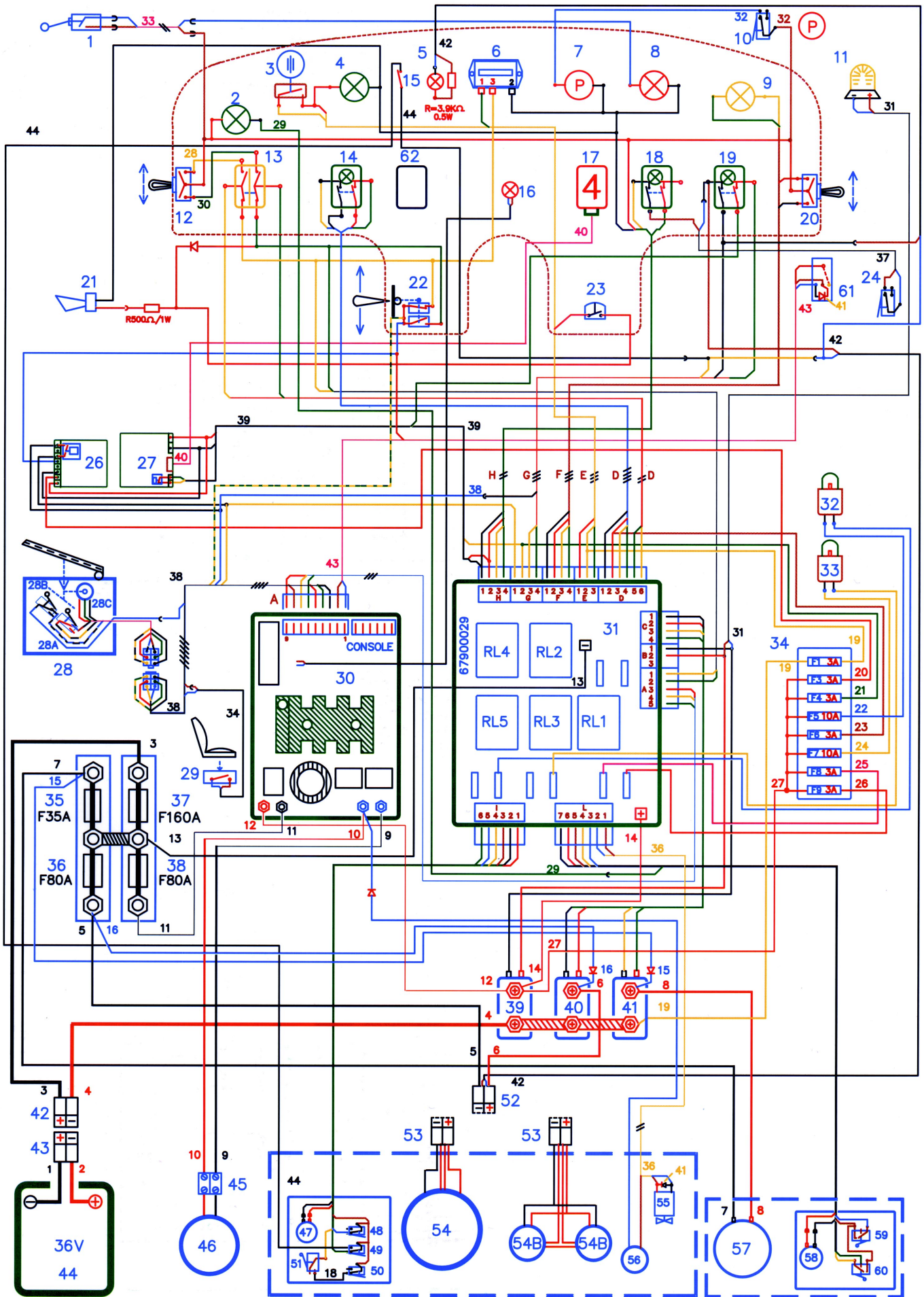

ScrubMaster 26R

Electrical Components Parts List

Item	Part Number	Description
1	72199004	Float switch solution tank empty
2	72300203	Signal lamp green 36V actuator down squeegee
3	72107005	Contact key ON/OFF general
4	72300203	Signal lamp green 36V ON/OFF general
5	68033056	Led thermic protection brushes motor
6	72904002	Hourmetet
7	72300203	Signal lamp red 36V handbrake
8	72300204	Signal lamp red 36V solution tank empty
9	72300214	Signal lamp yellow 36V actuator brush base
10	911170	Microswitch handbrake
11	72905024	Winking light
12	40651110	Manipulator up/down squeegee
13	72101006	Bipolar switch yellow aut/man squeegee
14	72102005	Bipolar switch w/green signal lamp 36V suction Mtr.
15	72105015	Microswitch thermic reset
16		Led chopper alarms
17	72300117	Signal control batteries
18	72102005	Bipolar switch w/green signal lamp 36V solenoid valve
19	72102005	Bipolar switch w/green lamp brushes/sweeping motor
20	40651110	Manipulator up/down brushes/sweeping base
21	72905015	Buzzer reverse motion and horn
22	68303130	Mainpulator drive forward/backwards
23	72905009	Push button horn
24	72105009	Microswitch water cock
26	67900054	Check card delay brushes/sweeping motor
27	67903001	Check card batteries
28	74802008	Pedal drive control
28A	911170	Microswitch drive consent
28B	72105001	Microswitch brush consent
28C	67900057	Check card potentiometer
29	72105014	Safety switch operator seat
30	67900056	Chopper card 36V/70A MOS
31	67900029	Check card control and commands
32	72106006	Circuit breaker 3,5A actuator brushes/sweeping
33	72106006	Circuit breaker 3,5A actuator squeegee
34	72400014	Fuseholder 8-ways
35	72403502	Fuse protected 35A suction motor
36	72408001	Fuse protected 80A brushes motor
37	72416001	Fuse protected 150A general batteries

Item	Part Number	Description
38	72408001	Fuse protected 80A chopper
39	68430110	Remote control switch general
40	68430110	Remote control switch brushes motor
41	68430110	Remote control switch suction motor
42	72700014	Connector male 80A
43	72700013	Connector female 80A
44		Batteries
45	67200220	Terminal 10x2 geared motor
46	68200220	Geared motor traction 450W
47	66200470	Actuator brushes/sweeping base
48	72105009	Stop brushes/sweeping base up
49	72105009	Stop brushes/sweeping motor
50	72105009	Stop brushes/sweeping base down
51	72105009	Stop brushes/sweeping base down
52	72700013	Connector female 80A
53	72700014	Connector male 80A
54	68230240	Brushes motor
54B	68230480	Sweeping motor
55	68533010	Coil solenoid valve solution
56	68701190	Pump 36V
57	68130430	Suction Motor 36V
58	68230550	Geared motor squeegee
59	72105003	Stop squeegee up
60	72105003	Stop squeegee down
61	68303150	Commutator drive speed
62	882343	Black cover
F1	72400301	Fuse 3A general key-chopper-signal lamps
F3	72400301	Fuse 3A up.down brushes - squeegee MAN
F4	72400301	Fuse 3A control brushes motor
F5	72401001	Fuse 10A actuator brushes base
F6	72400301	Fuse 3A control suction motor
F7	72401001	Fuse 10A actuator squeegee
F8	72400301	Fuse 3A control pump/solenoid valve
F9	72407501	Fuse 3A pump/solenoid valve
RL1	887550	Relay pump/solenoid valve
RL2	68420510	Relay squeegee up
RL3	68420510	Relay squeegee down
RL4	68420510	Relay brushes/sweeping base up
RL5	68420510	Relay brushes/sweeping base down

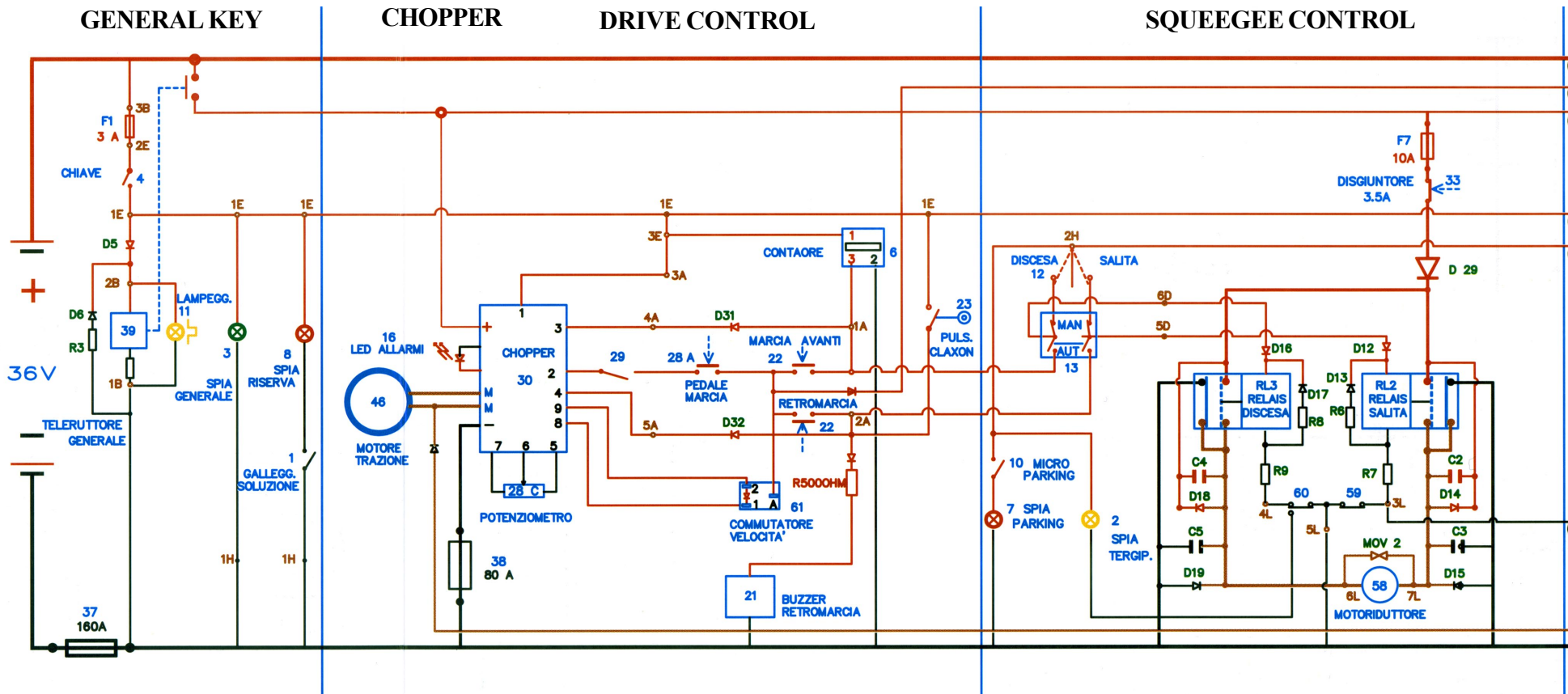

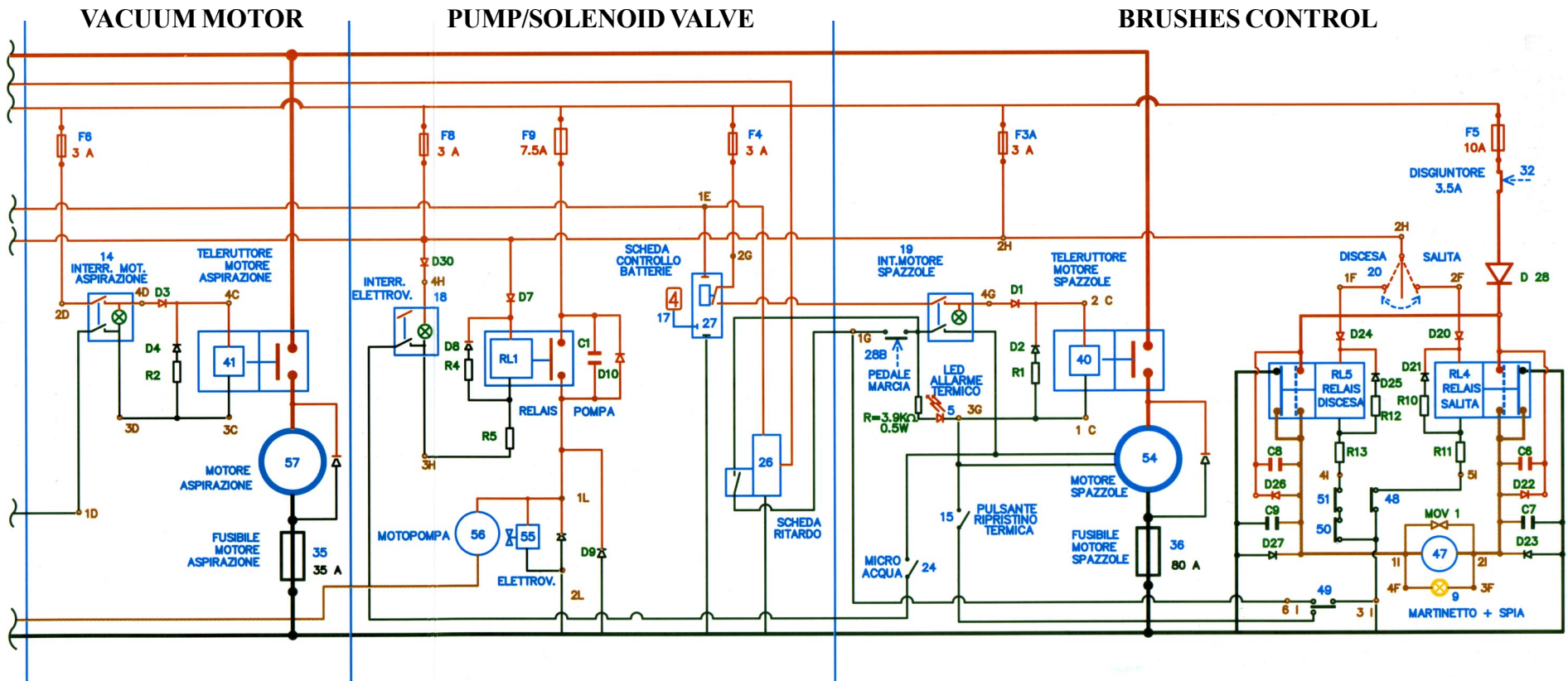

ScrubMaster 26R Electrical Cables Parts List

Item	Part Number	Description
1-2	68022120	2 Cables black - connector 80A - 1/2
3-4	68022121	2 Cables black-red + connect. 80A - 3/4
5-6	68022122	2 Cables black-red + connect. 80A - 5/6
7-8	68022123	2 Cables black-red + connect. 30A - 7/8
9-10	68022124	2 Cables black-red - 9/10
11	68022125	Cable black - 11
12	68022126	Cable red - 12
13	68022127	Cable black - 13
14	68022128	Cable red - 14
15	68022129	Cable blue with diode - 15
16	68022130	Cable blue with diode - 16
18	68022132	Cable black - 18
19	68022133	2 Cables yellow - 19
20	68022134	Cable red - 20
21	68022135	Cable green 21
22	68022136	2 Cables blue - 22
23	68022137	Cable brown -23
24	68022139	2 Cables yellow - 24
25	68022140	Cable violet -25
26	68022141	Cable red - 26
27	68022142	7 Cables red - 27
28	68022143	Cable yellow - 28
29	68022144	Cable green - 29
30	68022145	Cable green - 30

Item	Part Number	Description
31	68022147	2 Cables blue-brown - 31
32	68022148	2 Cables blue-brown - 32
33	68022149	2 Cables blue-brown - 33
34	68022150	2 Cables blue-brown - 34
36	68022152	4 Cables blue-brown - 36
37	68022153	2 Cables blue-brown - 37
38	68022154	7 Cables - 38
39	68022155	Cable flat with bridges black-red - 39
40	68000892	Cable flat - 40
41	72500008	Diode IN4007 with faston M.F
42	68022156	4 Cables blue-br + bridge black +LED - 42
43	68022167	3 Cables red-blue-brown - 43
44	68022168	2 Cables black - 44
A	68022157	Cable with terminal board - A
B	68022158	Cable with terminal board - B
C	68022159	Cable with terminal board - C
D	68022160	Cable with terminal board - D
E	68022161	Cable with terminal board - E
F	68022162	Cable with terminal board - F
G	68022163	Cable with terminal board - G
H	68022164	Cable with terminal board - H
I	68022165	Cable with terminal board -I
L	68022166	Cable with terminal board - L

PACIFIC

2259 Sheridan
Muskegon, Michigan 49442
Ph: (800) 968-1332 Fax: (231) 773-1642
www.nextwaveofclean.com