



Electronic Service Manuals

This electronic document is provided as a service to our customers. We do not create the contents of the information contained in this document. Should you have detailed questions pertaining to the information contained in this document, you may contact Michco, or the manufacturer which provided the original information in this electronic deliverable. Michco's only part in this electronic deliverable was the electronic assembly process.

You may contact Michco through the following methods:
Phone (517) 484-9312 or (800) 331-3339 MI, OH, IN only
2011 N. High St. -- Lansing, Michigan -- 48906
Fax: (517) 484-9836
Email: CustServ@Michco.com
Web site: www.Michco.Com
Parts Web site: www.FloorMachineParts.Com

Order Parts on Line at:
www.FloorMachineParts.Com

Directly to Parts & Service:
By Email: **Shop@Michco.com**
By Fax: (517) 702-2041
By Voice: Use numbers above.

Serving the Cleaning Industry Since 1922

Notice: All copyrighted material remains property of original owners, all trademarks are property of respective owners. Manuals are subject to Manufacturer's reproduction limitations. Originals or reproductions were provided by manufacturers through a request. We make no warranty as to the correctness of information provided in this document and you assume all risk.

TRIUMPH 430

SELF-CONTAINED CARPET EXTRACTOR

INTRODUCTION

OPERATING & MAINTENANCE INSTRUCTIONS

READ THIS BOOK

This operator's book has important information for the use and safe operation of this machine. Read this book carefully before starting the machine. Keep this book and tell all operators to read the book. If you do not follow the instructions, you can cause an injury or damage equipment, furniture or buildings.

For new books write to:

Pacific Steamex, Inc.
2259 S. Sheridan
Muskegon, MI 49442-6252

Carefully inspect all components to ensure that there is no concealed freight damage. If such damage is discovered, file a "CONCEALED DAMAGE REPORT" immediately with the delivering carrier.

The contents of this manual are based on the latest product information available at the time of publication. Pacific Steamex reserves the right to make changes or improvements to its machines without notice.

FOR YOUR CONVENIENCE, RECORD THE FOLLOWING INFORMATION:

MODEL _____

SERIAL NUMBER _____

PART NUMBER _____

DATE PURCHASED _____

INTRODUCTION

The **Pacific Steamex Triumph 430** is a fully self-contained, portable carpet extractor system.

The Triumph 430 has a 60 psi solution pump and a two (2) jet spraying system to apply solution to the carpet.

A rotating brush is driven by a cogged belt system at approximately 1000 RPM's. This brush provides a very aggressive agitation of the solution into the carpet fibers to loosen ground-in dirt. The chevron pattern of the brush bristles channels the dirty water to the center of the 12" aluminum vacuum head for better extraction.

The two-stage vacuum motor on the Triumph 430 is capable of 80 inches of water lift. The Triumph 430 extracts virtually all of the dirty solution from the carpet fibers, which dramatically reduces drying time.

The Triumph 430 is a very "user friendly" machine. All controls are located at the top of the handle grips, literally at your fingertips. The 430 has a 4 gallon solution tank and a 3 gallon lift out recovery tank.

Grounding Instructions

This machine must be grounded. If it should malfunction or break down, grounding provides a path of least resistance for electric current to reduce the risk of electric shock. This machine is equipped with a cord having an equipment-grounding conductor and grounding plug. The plug must be inserted into an appropriate outlet that is properly installed and grounded in accordance with all local codes and ordinances.

WARNING - Improper connection of the equipment-grounding conductor can result in a risk of electric shock. Check with a qualified electrician or service person if you are in doubt as to whether the outlet is properly grounded. Do not modify the plug provided with the machine - if it will not fit the outlet, have a proper outlet installed by a qualified electrician.

This machine is for use on a nominal 120-volt circuit, and has a grounded plug that looks like the plug illustrated in figure A. A temporary adapter that looks like the adapter illustrated in figures B and C may be used to connect this plug to a 2-pole receptacle as shown in figure B if a properly grounded outlet is not available. The temporary adapter should be used only until a properly grounded outlet (figure A) can be installed by a qualified electrician. The green colored rigid ear, lug, or the like extending from the adapter must be connected to a permanent ground such as a properly grounded outlet box cover. Whenever the adapter is used, it must be held in place by a metal screw.

NOTE: In Canada, the use of a temporary adapter is not permitted by the Canadian Electrical Code

EXTENSION CORDS

Use only three-wire 14/3 or larger gauge approved extension cords that have three-prong grounding type plugs and three-pole receptacles that accept the appliance's plug. Replace or repair any damaged cords or plugs.

When servicing, refer to authorized person only. Use only identical replacement parts.

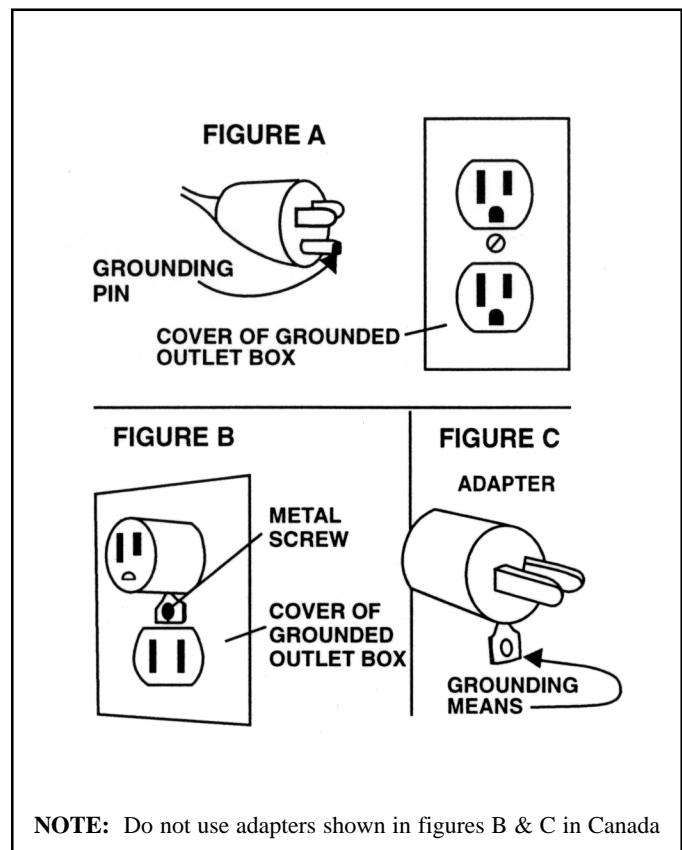

IMPORTANT SAFETY INSTRUCTIONS

When using an electrical appliance, basic precautions should always be followed, including the following:

READ ALL INSTRUCTIONS BEFORE USING THIS MACHINE

WARNING: To reduce the risk of fire, electric shock, or injury:

1. You must have training in the operation of this machine before using it.
2. Machines can cause an explosion when near flammable materials and vapors. Do not use this machine with or near fuels, grain dust, solvents, thinners, or other flammable materials.
3. Do not operate this machine unless it is completely assembled.
4. Do not use this unit for dry pick-up of dust or debris.
5. To prevent electric shock, always remove the electrical plug from the electrical outlet before doing any repairs or maintenance to this machine.
6. To prevent injury, always remove the electrical plug from the electrical outlet before leaving the machine.
7. Maintenance and repairs must be done by authorized personnel only.
8. Do not immerse. To reduce the risk of electrical shock, use only on carpet moistened by the cleaning process. Protect the machine from rain. Keep the machine in a dry building. Always clean the machine with a clean dry cloth.
9. Always use a three-wire electrical system connected to the electrical ground. For maximum protection against electrical shock, use a circuit that is protected by a ground fault circuit interrupter. Consult your electrical contractor.
10. To prevent damage to the power cord, do not move this machine over the power cord. Always lift the power cord over the machine. Do not pull or carry cord, use cord as a handle, close a door on cord, or pull cord around sharp edges or corners. Keep cord away from heated surfaces.
11. Make sure all switches are turned off before plugging or unplugging it power cord into/from a wall receptacle.
12. Do not use water that is hotter than 60°C (140°F).
13. To prevent damage to the solution system components do not store in freezing temperatures without proper maintenance.
14. Do not allow to be used as a toy. Close attention is necessary when used near children.
15. Do not use with damaged cord or plug. If the machine is not working as it should, has been dropped, damaged, left outdoors, or dropped into water, return it to a service center.
16. Do not unplug by pulling on cord. To unplug, grasp the plug, not the cord.
17. Do not handle the plug or machine with wet hands.
18. Do not put any object into openings. Do not use with any opening blocked. Keep free of dust, lint, hair and anything that may reduce the airflow.
19. Keep hair, loose clothing, fingers and all parts of body away from openings and moving parts.
20. Do not pick up anything that is burning or smoking, such as cigarettes, matches or hot ashes.
21. Use extra care when cleaning on stairs.

SAVE THESE INSTRUCTIONS

OPERATING PROCEDURES

WARNING! For the safe operation of this machine follow the instructions given in this booklet and the training given by your supervisor. Failure to do so can result in personal injury and/or damage to machine and property!

DO NOT OPERATE MACHINE IN AN EXPLOSIVE ENVIRONMENT!

NEVER USE THIS MACHINE TO PICK UP VOLATILE OR EXPLOSIVE MATERIALS!

The model shown in this manual is intended for commercial use.

PREPARATION

1. Check **power cord, plug** and **strain relief** for worn or damaged insulation. Repair or replace if necessary.
2. Confirm the **quick connects** located at the back of the machine are properly attached. This is the water supply line and solution water will not be allowed to flow through to the jets if this connection isn't secure.
3. Lock the **brush assembly** in the up position for storage or transport. This is done by pulling up on the **black knob/lift mechanism** at the front of the machine and allowing the lift stop to rest on the bracket.
4. Inspect the **vacuum head** and **brush** by tilting the machine backwards.
 - a) **Vacuum Head:** Check for any damage. Burrs on the contact surface may snag carpet fibers. Gouges, scratches and chipped areas can reduce vacuum performance.
 - b) **Brush:** Inspect for damaged or missing bristles, replace if necessary.Return the machine to the upright position.
5. Check the **inlet screen and filter bag** in the opening of the fresh water/solution tank for damage or debris. Holes in the screen can allow contaminants to enter the pump resulting in costly repairs. A clogged screen will reduce pump performance and may cause permanent damage.
6. Remove the clear dome on top of the recovery tank.
 - a) Inspect for damage to the **dome and gasket**. Dirt or debris on the gasket or sealing surface of the tank can cause a vacuum leak and reduce vacuum performance.
 - b) The **intake filter screen** should be clean of debris and checked periodically for any damage, replace if necessary.

Return the cover to its original position.

OPERATION

The following procedures are intended to describe and detail proper operation of your machine. Failure to follow these recommended procedures can reduce the machine's performance and may result in damage to the machine.

1. **Vacuum the area to be cleaned.** Your machine will do a more thorough job if the loose dirt and debris are removed before the extraction process begins.
2. **Add NON-FOAMING cleaning concentrate to the fresh water/solution tank.** Follow mixing instructions for 3 to 3-1/2 gallons of water. **Then fill the tank with warm water using the faucet/power fill adaptor.** Do not use water hotter than 60°C (140°F).

Or, you may mix the concentrate with 3 to 3-1/2 gallons of clean water in a CLEAN bucket, then pour the mixture into the solution tank.

DO NOT OVERFILL.

NEVER USE THE RECOVERY TANK'S DIRTY WATER TO FILL THE SOLUTION TANK!

3. **Ensure the water supply hose connection at the rear of the machine is secure.**
4. **Connect the power cord plug to a 115 volt grounded wall socket.** See Grounding Instructions. Use of an extension cord is not recommended. However, if one is necessary, use only a **14 gauge** or larger cord. Smaller or inferior cords are dangerous and may cause damage to your machine.
5. **Lower the brush assembly** by lifting the black knob off the storage/transport bracket.
6. **Turn on the vacuum switch at the control panel** to start the vacuum motor.

Note: The accessory pump switch is for use only with the accessory tools. See "OPERATING WITH ACCESSORY TOOLS".

7. **Pull backward during operation.** DO NOT ATTEMPT TO OPERATE IN A FORWARD DIRECTION. **Position yourself behind the machine, grasp the handle and depress the red momentary "Pump/Brush" switch on the top center of the handle.** This switch activates the brush drive motor and the pump to spray cleaning solution. Walk slowly backward and continue to depress the red switch to perform the cleaning process.

OPERATING PROCEDURES

8. **Release the red button approximately 6 inches before completing each pass.** The spray jets are located behind the vacuum head making it necessary to pull the machine a few inches further to pick up the last amount of solution dispensed onto the carpet.
9. **Tilt the machine back on the rear wheels and walk forward** to position the machine along side the previous pass (slightly overlapping).
10. As dirty solution is recovered, some foaming may be noted. Excessive foaming can be counteracted with liquid defoamer applied according to the chemical manufacturing directions. **Do not allow foam to rise into or near the dome; this will harm the vacuum motor.** Use defoamer or empty and flush the recovery tank.
11. To **empty the recovery tank**, remove the dome assembly and lift the tank out. Dispose of the recovered water properly.
12. **If streaking occurs** after a period of operating time, this means the solution (fresh water) tank is near empty. Streaking is eliminated by adding more water and chemical solution to the tank. **Empty the recovery tank every time you fill the solution tank.**
13. To **empty the solution tank** connect the Power Fill adaptor to the vacuum inlet on the front of the dome. Turn the vacuum switch on.

OPERATING WITH ACCESSORY TOOLS

1. To use an accessory tool disconnect the supply hose at the rear of the machine and connect the accessory tool hose .
2. Next, disconnect the machine's vacuum hose from the front of the dome assembly and connect the accessory tool vacuum hose to the dome.
3. Turn the vacuum and accessory pump switches on. Solution will be dispensed while the accessory tool trigger is depressed.

Watch the dome to make sure the recovery tank does not overflow.

Note: The pump motor is equipped with an automatic thermal protection device. If the motor overheats for any reason, the thermal protector will activate and automatically turn the motor off. If this occurs the operator should turn the manual pump switch to the off position and allow approximately fifteen minutes for the motor to cool. When the motor has cooled to a safe operating temperature, the thermal protector will automatically close and allow power to be supplied to the motor via the manual pump switch. The operator will be able to resume normal operation. If the pump motor shuts down repeatedly, it should be checked at an Authorized Service Center.

SERVICING

The TRIUMPH 430 self-contained extractor is designed and manufactured to provide years of trouble free service with a minimum of maintenance and service. The following recommendations are intended to assist the operator and Service Technician in performing routine maintenance.

WARNING: Always unplug your machine before performing any service. Severe personal injury could result if the electrical power is not disconnected.

After Each Use:

1. Clean the dome top, intake filter screen, gasket and recovery tank with fresh, clean water. Do not reinstall the dome until the next use, this will allow the recovery tank to dry out.
2. Flush the solution tank and inlet screen with clean water. Vacuum all water out using the Power Fill adaptor.
3. Remove any debris on the scrub brush, vacuum head and around the spray jets.

5. Make sure the brush assembly lift lever is locked in the raised position.
6. Store your machine in a dry, protected area. **Do not expose this machine to rain, standing water or freezing temperatures.**

Periodically:

After continuous or repeated use the **jets and check valves** will need cleaning: Unplug the cord and empty the recovery and solution tanks. Tilt the machine backward. Remove the jet caps, jets and check valves shown in the brush assembly illustration and soak in white vinegar until visible deposits are dissolved, then scrub with a soft bristle brush. **Note: jets and check valves should be replaced once a year**, because they tend to erode under extended use. This may cause overuse of solution and streaking.

AN AUTHORIZED SERVICE CENTER SHOULD PERFORM THE FOLLOWING PROCEDURES:

Drive Belt Adjustment and/or Replacement:

The cogged belt drive system rarely requires tightening. If the belt becomes loose from wear, it is time to replace it.

Follow this procedure: Remove acorn nut and thru-bolt from brush chassis lift handle. Gently tilt machine backwards. While holding the base of the brush housing with one hand, release the lift handle from the up/locked position. The brush housing pivots on a hinge that doesn't need to be removed. Loosen the two motor bracket mounting bolts with a 7/16" wrench. **DO NOT REMOVE THE BOLTS UNLESS YOU ARE REPLACING THE MOTOR.** Slide the motor away from the brush to tighten the belt or toward the brush to remove. If you are replacing the belt it will be necessary to remove the brush assembly to install a new one. Remove the two axle shaft retaining screws located on either side of the brush housing. Loop belt over cog and reinstall brush.

Unlike a "V" type belt, the cogged belt is run with basically zero deflection. To test the belt tension, hold the belt between your thumb and forefinger and twist to the side. It should turn approximately 90° with little effort. If it twists more than 90°, retighten the belt.

Additional service information is available from your local Pacific Steamex Distributor or through our Technical Service Department.

WIRING DIAGRAM TRIUMPH 430

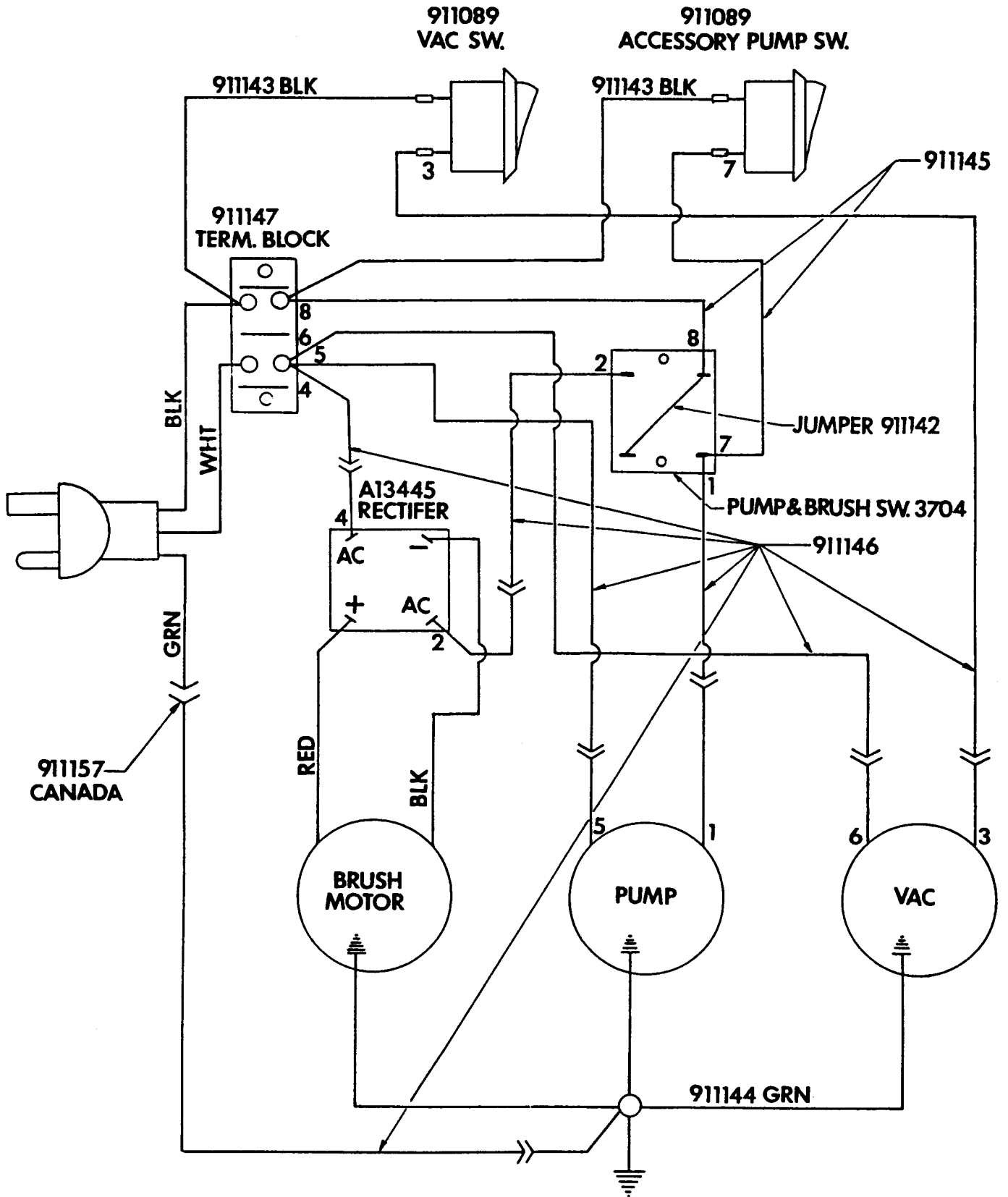

Triumph 430 Drawing 1

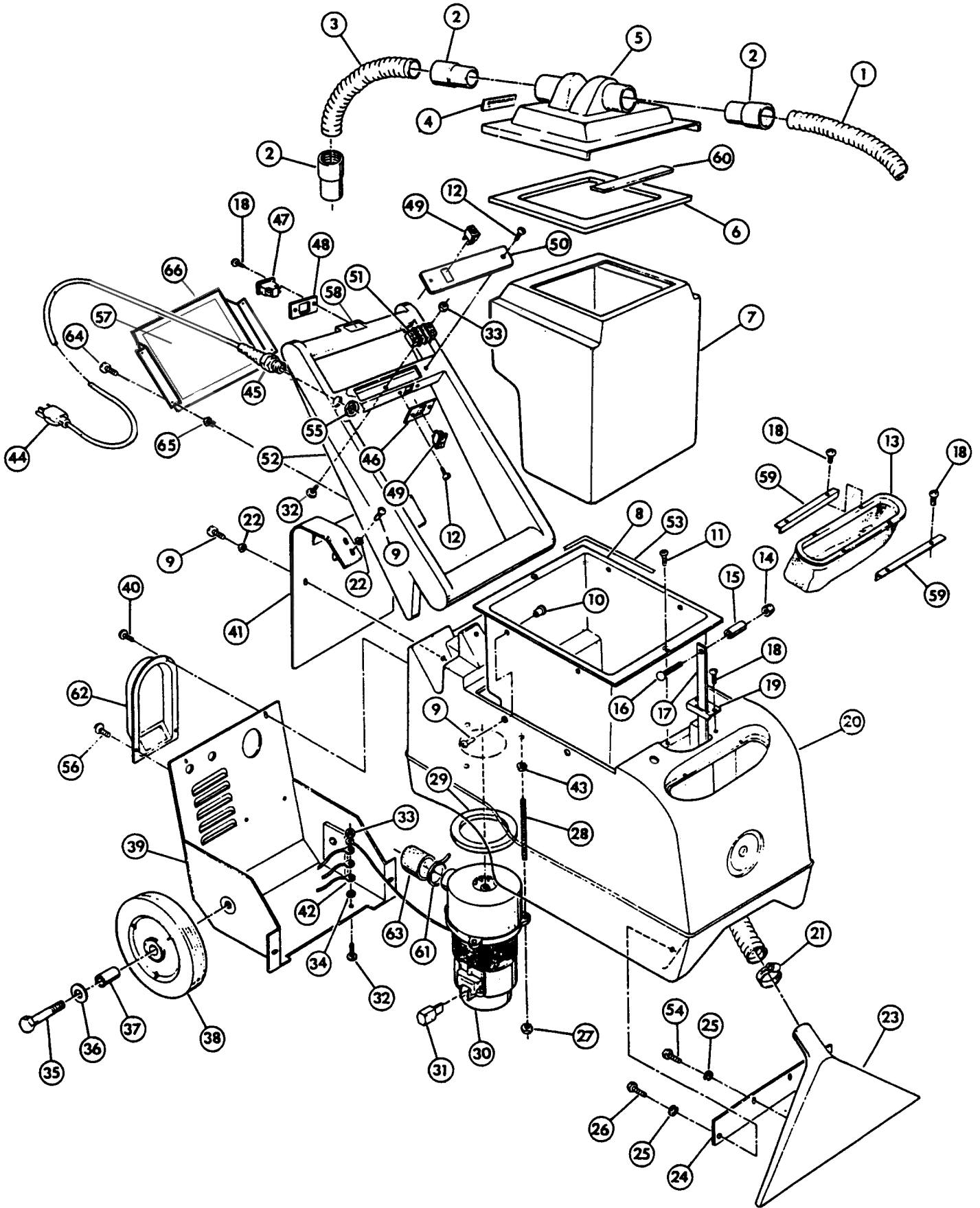

Triumph 430 Drawing 1

ITEM	PT #	DESCRIPTION	Qty.	ITEM	PT #	DESCRIPTION	Qty.
1	204170	Hose - Vac Head, 17"	1	33	W106D	Nut - 10-24 Hex	6
2	3698	Cuff	3	34	W124D	Washer #10 Int. Tooth	7
3	204171	Hose - Vac Short, 6"	1	35	962103	Bolt 3/8-16 x 2-1/4 HHCS	2
4	D161C	Decal - Warning Add Defoamer	1	36	980007	Washer 5/16 Flat	2
5	202770	Dome	1	37	208270	Spacer Wheel	2
6	203470	Gasket - Dome	1	38	209771	6" Wheel, Grey	2
7	202472	Recovery Container	1	39	201972	Chassis Wheel	1
8	208671	Liner	1	40	962056	Screw 1/4-20 x 3/8 PHP	4
9	W172D	Screw 10-24 x 3/8 PHP	10	41	202370	Cover - Rear	1
10	920618	Nut	4	42	A13059	Terminal	4
11	W167D	Screw 10-24 x 3/8 FHP	2	43	920004	1/4-20 Hex Nut	3
12	W136D1	Screw #8 x 1/2 THP	4	44	908059	Cord Assembly 25'	1
13	243301	Filter	1	45	A13020	Strain Relief	1
14	W162D	Nut - Acorn 1/4-20	1	46	206671	Plate - Switch Accessory	1
15	205070	Knob	1	47	3704	Switch Momentary	1
16	962086	Bolt 1/4-20 x 1-1/4	1	48	206651	Plate - Switch	1
17	203970	Handle Lift Bracket	1		206672	Plate Switch CSA	1
18	W136D	Screw #8 x 1/2	8	49	911089	Switch Rocker	2
19	202470	Catch - Brush Lift	1	50	206670	Plate Switch	1
20	201374	Body - Machine	1	51	911147	Terminal Block	1
	201372	Body - Machine CSA	1	52	203977	Handle, Black	1
21	S611A	Clamp - Hose	1		203972	Handle CSA	1
22	980015	Washer #10 Ext. Tooth	7	53	203474	Gasket Tacky Tape, Grey	4 ft
23	204573	Vac Head	1	54	962068	Screw - 1/4-20 x 5/8 Hex HO	2
24	208570	Support - Vac Head	1	55	920619	Nut - 1/2 Pipe Lock	1
25	980002	Washer - Split	14	56	962079	Screw - 10 - 24 x 1/4 PHP	2
26	962006	Screw 1/4-20 x 1/2 PHP SS	2	57	205186	Label, Operation	1
27	920011	Nut 1/4-20 Elastic Stop	3	58	205171	Label, Push to Clean	1
28	208451	Stud - Vac Motor Mount	3	59	200871	Bracket Filter	2
29	603473	Gasket	1	60	203473	Gasket	1
30	245203	VAC. MOTOR - 115V	1	61	911104	Cable Tie	1
		Vac Motor - 230V		62	202771	Deflector	1
31	200951	Carbon Brushes - 115V Vac Motor	2	63	202772	Air Duct	1
		Carbon Brushes - 230 V Vac Motor	2	64	W343D	Screw, 10-24x1 PHP	4
32	W153D2	Screw 10-24 x 3/4	3	65	920026	Jacknut 10-24 Zinc	4
					202773	Dome Assembly Complete	
						Including Items 4,5,6 & 60	

Triumph 430 Drawing 2

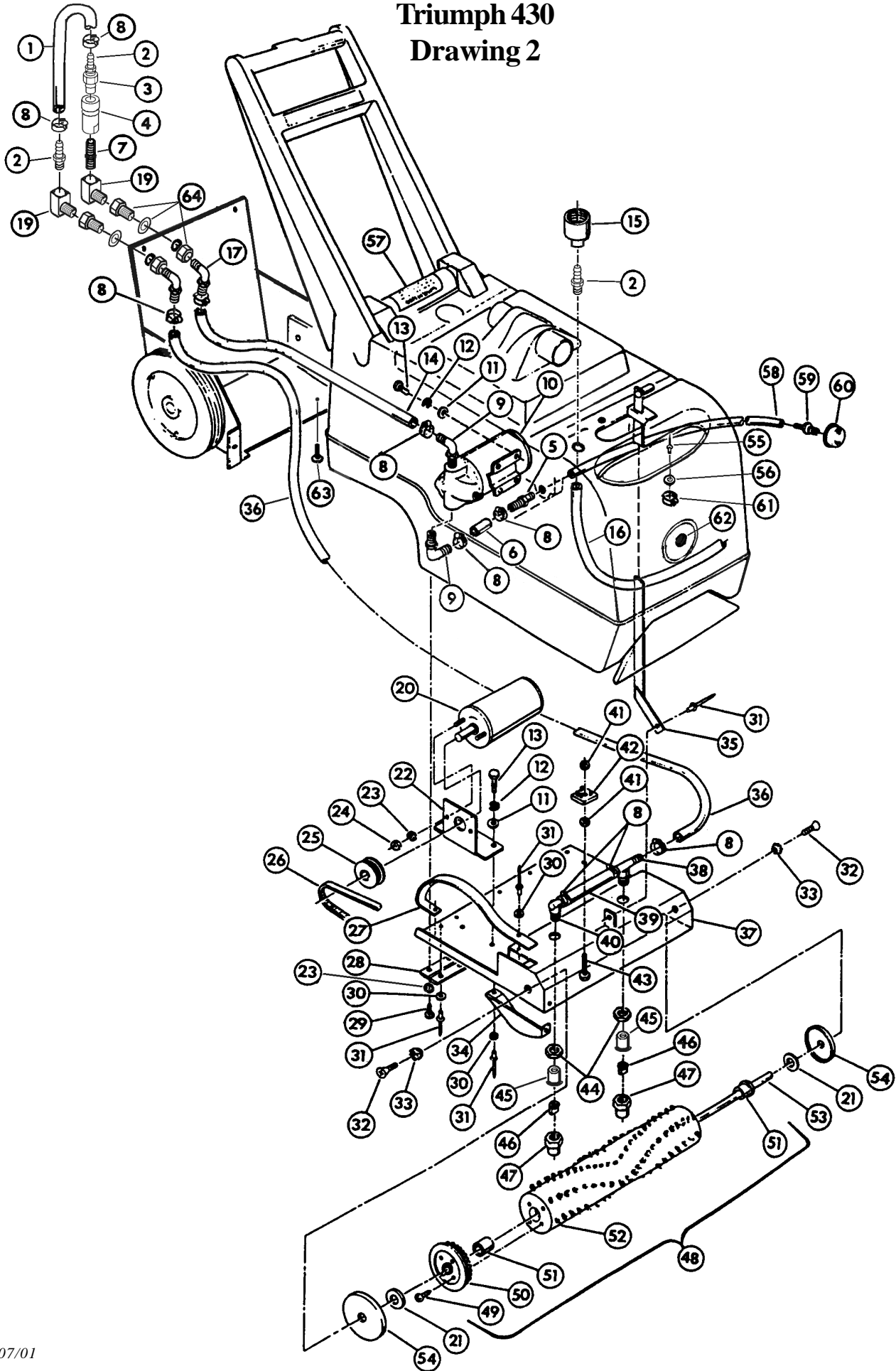

Triumph 430

Drawing 2

Item	Part No.	Description	Qty.
1	204182	Hose – 12” Reinforced	1
2	203359	Fitting – 3/8 Hose Barb	3
3	203302	Quick Connect – ¼ Male	1
4	203308	Quick Connect – ¼ Female	1
5	203359	Fitting– 3/8 Hose Barb	1
6	204176	Hose, Tank to Pump	1
7	205752	Nipple – Close ¼ NPT	1
8	S453P	Clamp - Hose	10
9	3765	Elbow - 90° 3/8 to 3/8	2
10	217003	Pump 60 Psi 115V	1
	217004	Pump 60 PSI - 230V	1
		Diaphragm Kit	1
	209406	Bypass Valve Kit	1
11	980004	Washer - 1/4" Flat	6
12	980002	Washer - 1/4" Lock	4
13	W169D	Screw - 1/4-20 x 1/2" HH CS SS	6
14	204181	Hose	1
15	240202	Adaptor, Hose to Dome	1
16	244107	Hose, Adaptor Fill	1
17	3771	Elbow - 1/4" to 3/8"	2
19	T4027	Brass 90° St. Elbow ¼	2
20	A13017	Motor - Brush 115V	1
	3760	Motor - Brush 230V	1
21	980612	Washer - Thrust	2
22	200870	Bracket - Motor	1
23	W124D	Washer - #10 Int. Tooth	7
24	W329D	Nut #10 - 32 Hex SS	2
25	3708	Cog Motor	1
26	3740	Drive Belt	1
27	203670	Guard Splash	1
28	A129671	Hinge	1
29	W172D	Screw 8 - 32 x 3/8 RHP MS S/S	5
30	980033	Washer #6 Flat S/S	9
31	W363D	Pop Rivet	5

Item	Part No.	Description	Qty.
32	W353D	Screw 1/4-20 x 1/2" FHP	2
33	980032	Washer	2
34	A13438	Guard - Belt	1
35	203970	Bracket - Lift	1
36	204174	Hose	1
37	D13175	Chassis - Brush	1
38	S999P	Tee Fitting	1
39	204178	Hose	1
40	S452P	Elbow - D.T. Jet	1
41	920617	Nut - 8 - 32 Hex Nylon	2
42	A13445	Rectifier	1
43	W205D	Screw - 8 - 32 x 1" PHS Nylon	1
44	W166D	Nut - Brass Jam	2
45	209472	Check Valve	2
46	S982P	Jet 11004 Brass	2
47	S973P	Cap - Jet	2
48	200970	Brush Assembly Complete	1
49	962062	Screw #6	4
50	3743	Cog Brush	1
51	3677	Bearing - Rulon	2
52	3731	Brush Only	1
53	217701	Shaft Brush	1
54	213601	Guard Brush Thread	2
55	930005	Rivit Alum Pop	1
56	W107D	Washer, 3/16 Flat S/S	1
57	D167C	Label Warnings	1
	205175	Label Warnings CSA	1
58	204179	Tubing	2.25'
59	S535P	Barb Fitting	1
60	S626P	Filter	1
61	612001	Clamp	1
62	221373	Plug Button	1
63	W153D2	Screw, Grounding	1
64	T4056	Brass Coupling ¼ w/Nut & Washer	2

WARRANTY POLICY
PACIFIC STEAMEX INC. LIMITED WARRANTY

The **Pacific Steamex Inc.** Triumph 430 Carpet Extractor has been manufactured, tested and inspected in accordance with specific engineering requirements and is **WARRANTED** to be free from defects in workmanship and materials as follows:

Five (5) years parts, One (1) year labor – Polyethylene components.
One (1) year parts and labor – All other components unless excluded below.

This warranty extends to the original user/purchaser and only when used, operated and maintained in accordance with **Pacific Steamex Inc.** Operating and Maintenance instructions.

This warranty does not apply to the following wear parts and accessories of the machine including:

Part Number	Part Name
908059	Cord Assembly
209770	Wheel
243301	Filter
209472	Check Valves
S982P	Jet
3740	Belt
3731	Brush
200951	Carbon Brush, 115V Motor

Nor does it apply to damage or failure caused by improper use, abuse or neglect. Warranty credit or replacement of return parts including motors, pumps, etc., is subject to incoming inspection of those items.

To secure repair under this warranty, the following procedure should be taken:

- The inoperative machine or warranted parts must be delivered to the authorized dealer with shipping and delivery charges prepaid. If unable to locate the Dealer, you may contact **Pacific Steamex Inc.** at the address listed herein for the location of the nearest **Pacific Steamex Inc.** repair center or agent or for other instructions pertaining to your warranty difficulty.
- Upon compliance with the above warranty procedure, all warranted repairs would be completed at no additional charge or cost to the user.
- Only **Pacific Steamex Inc.** or its authorized dealers and agents may make no charge warranty repairs on this product. All others do so at their own risk.

This warranty limits **Pacific Steamex Inc.** liability to the repair of the product and/or warranted parts replacement and does not include incidental or consequential damages arising from the use of a **Pacific Steamex Inc.** machine whether defective or not.

This warranty is in lieu of all other expressed or implied warranties and is extended to the original purchaser/user.

PACIFIC STEAMEX, INC.
2259 S. SHERIDAN
MUSKEGON, MICHIGAN 49442-6252
800-968-1332
FAX 1-800-863-9536