



Electronic Service Manuals

This electronic document is provided as a service to our customers. We do not create the contents of the information contained in this document. Should you have detailed questions pertaining to the information contained in this document, you may contact Michco, or the manufacturer which provided the original information in this electronic deliverable. Michco's only part in this electronic deliverable was the electronic assembly process. By providing this manual on line we are not guaranteeing parts availability.

You may contact Michco through the following methods:

Phone (517) 484-9312 or (800) 331-3339

2011 N. High St. -- Lansing, Michigan -- 48906

Fax: (517) 484-9836

Email: CustServe@Michco.com

Web site: www.Michco.Com

Parts Web site: www.FloorMachineParts.Com

Order Parts on Line at:

www.FloorMachineParts.Com

Directly to Parts & Service:

By Email: **Shop@Michco.com**

By Fax: (517) 702-2041

By Voice: Use numbers above.

Serving the Cleaning Industry Since 1922

Notice: All copyrighted material remains property of original owners, all trademarks are property of respective owners. Manuals are subject to Manufacturer's reproduction limitations. Originals or reproductions were provided by manufacturers through a request. We make no warranty as to the correctness of information provided in this document and you assume all risk. By placing these manuals on line we are not declaring our corporation to be an manufacturer authorized dealer or provider, please check our web site for authorized manufacturers we represent.

NOBLES

INDUSTRIES, INC.

Parts Illustration

Extract-A-Vac Model 105

ASSEMBLY NO. 115V K23834
Start with Serial No. 123983

WARNING
TO AVOID ELECTRIC
SHOCK DO NOT
EXPOSE TO RAIN —
STORE INDOORS

645 E. 7th ST., ST. PAUL, MINN. 55106
TELEPHONE (612) 771-5581
TELEX NO. 29-7403

FORM 402-11771
REVISED 1/82

EXTRACT-A-VAC
PART NO. K23834
 Start with Serial No. 123983

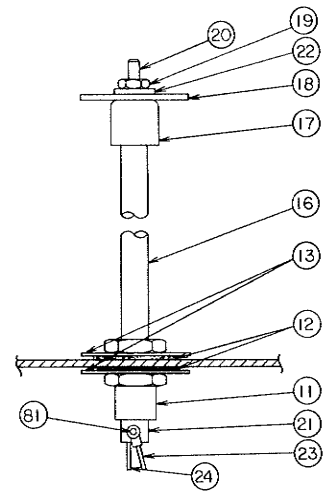
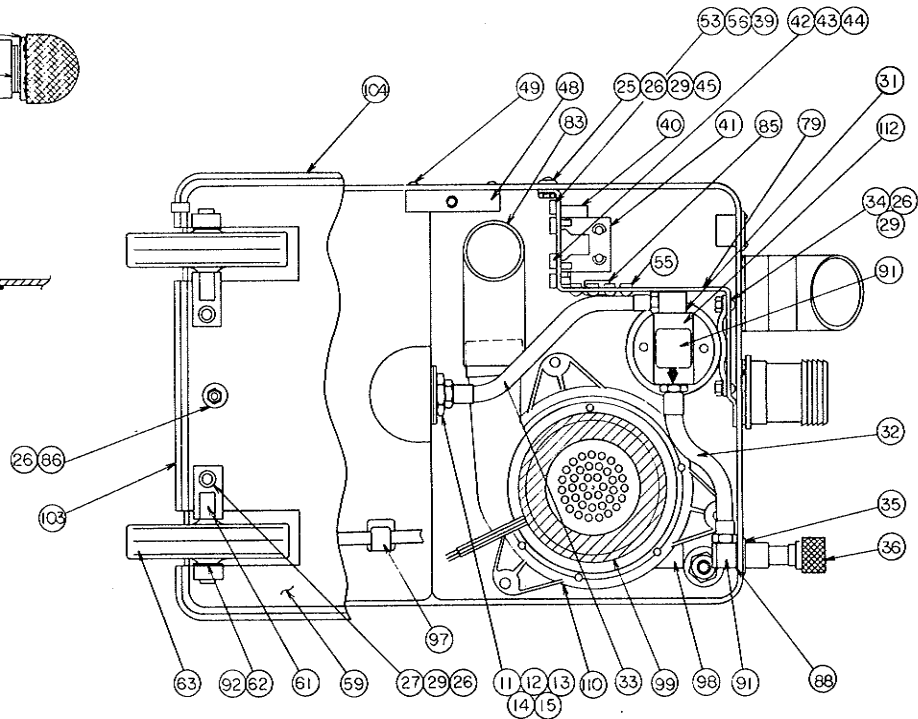
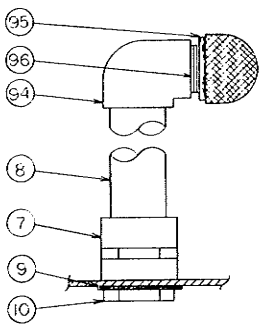
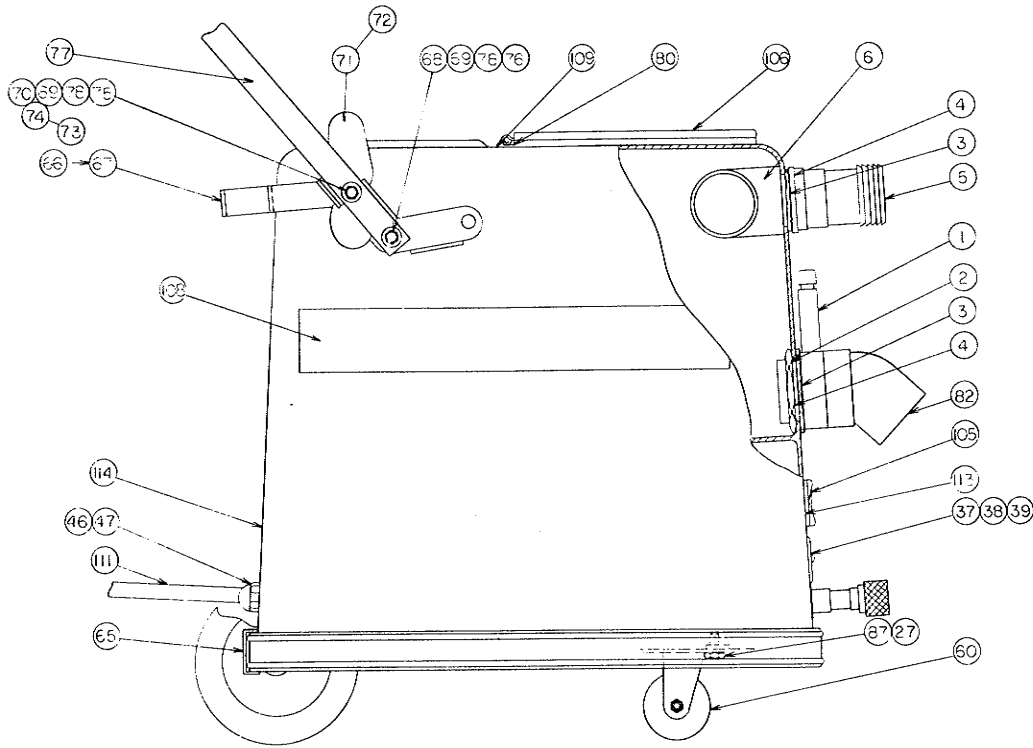

ITEM	PART NO.	DESCRIPTION	ITEM	PART NO.	DESCRIPTION
1	23835	Gate Valve, Waste	63	19036	Wheel 6"
2	19007	Gasket	64	23114	Wire Lead
3	19005	Gasket	65	19058	Bumper Clip
4	19008	Nut 1-1/2"	66	19067	Handle Brkt. Weld LH
5	19053	Adaptor	67	19073	Handle Brkt. Weld RH
6	19006	Elbow 1-1/2 x 1-1/2	68	19068	Scr. Flat 1/4-20 x 1-3/4" Long
7	20301	Adaptor 2" Socket x 2" P.T.	69	19069	Gasket
8	20300	Standpipe 2" x 10-1/4"	70	19065	Scr. Flat 1/4-20 x 1-1/2"
9	20307	Washer, Poly	71	19059	Latch RH
10	20308	Reducer Bushing	72	19070	Latch LH
11	19017	Bulkhead Fitting	73	19064	Spring Handle LH
12	19018	Gasket	74	19072	Spring Handle RH
13	20318	Washer S.S.	75	19063	Spacer, Handle
14	19016	Sol. Screen Filter	76	19071	Spacer, Handle
15	15285	1/4" Close Nipple	77	19062	Handle
16	20319	1/4" P.V.C. Pipe	78	19281	Cap Nut 1/4-20
17	20316	1/4" P.V.C. Pipe Cap	79	23844	Mounting Bracket
18	20315	Washer Rubber	80	20902	Pop Rivet 1/8 x 3/16" Long
19	20306	P.V.C. 1/4-20 Nut	81	20305	Screw
20	20303	Screw 1/4-20 x 1	82	19030	Elbow 45° x 2" Socket
21	20302	1/4" N.P.T. Nipple	83	23845	2" Hose 10" Long
22	20304	1/4" P.V.C. Washer	84	23542	Splice Connectors
23	19123	Wire Lead	85	19461	Heyco Plug
24	19122	Lead Asm.	86	20337	Flat Washer
25	19010	5/16 Chrome Washer	87	19512	Lockwasher
26	19031	Nut, Keps 1/4-20	88	19767	Washer
27	19037	Screw 1/4-20 x 1/2"	91	21330	Pressure Switch
29	19273	Washer, Flat	92	20853	Spring Washer
31	21260	Fitting, Elbow 90°	94	23846	Elbow 2" x 1-1/2" THD
32	23836	Hose Asm. 7-3/4" Long	95	23847	Suction Line Strain
33	23837	Hose Asm. 9-1/2" Long	96	23848	1-1/2" Close Nipple
34	23838	Screw 1/4-20 x 3/4" Long	97	19259	Wire Clip
35	19048	Washer	98	23849	Motor Gasket
36	15296	Quick Coupling	99	23850	Motor Gasket
37	20906	Receptacle	100	23851	Adaptor Terminal
38	20872	Screw 6-32 x 1/2" Long	101	19024	1/4" Terminal
39	19274	Nut, Hex 6-32	102	22547	Ground Terminal
40	19056	Liquid Level Sensor	103	19032	Bumper 10"
41	19057	VC Relay	104	19033	Bumper 60-1/2"
42	19280	Screw 10-24 x 1/2" Long	105	19417	Switch
43	19420	Lockwasher # 10	106	19009	Cover Asm.
44	19383	Keps Nut # 10-24	108	19101	Decal
45	23839	1/4-20 x 3/4" Screw	109	C19002	Sol. Tank Decal
46	19041	Cord Connector Nut	110	23852	115V. Vac Motor Asm.
47	19066	Cord Connector	111	23853	Cord, Supply Asm. 115V
48	19040	Angle Bracket	112	20903	Pump, Flojet 115V.
49	19038	Pop Rivet 3/16 x 1/2	113	A19001	Decal, On-Off 115V.
50	20424	Wire Lead, White	114	23862	Tank, Fiberglass 115V.
51	19124	Jumper Lead	115	23116	Wire Lead
52	20425	Wire Lead, Black	116	23841	Ground Clip
53	23108	Screw # 6-32x3/4			
54	23840	Wire Lead, White			
55	19128	Wire Lead, Black			
56	23109	Lockwasher # 6 INT.			
58	23842	Wire Harness			
59	23843	Base Plate, Weldment			
60	19042	Caster 2-1/2"			
61	19039	Axle, Wheel			
62	19035	Flat Washer			

VAC & SOLUTION HOSE ASSEMBLY
Assembly No. C22861

- | | | | |
|----|----------|---|----------------------------|
| 1. | C22861 | 1 | Assy - Vac & Solution Hose |
| 2. | K15037 | 7 | Hose Tie |
| 3. | K22864 | 1 | Vac Hose (Includes 4 - 6) |
| 4. | K6074 | 1 | Cuff |
| 5. | K6075 | 1 | Cuff |
| 6. | K6073-25 | 1 | Vac Hose |
| 7. | K22865 | 1 | Solution Hose |
| 8. | K15284 | 2 | Plug, Quick Coupler |

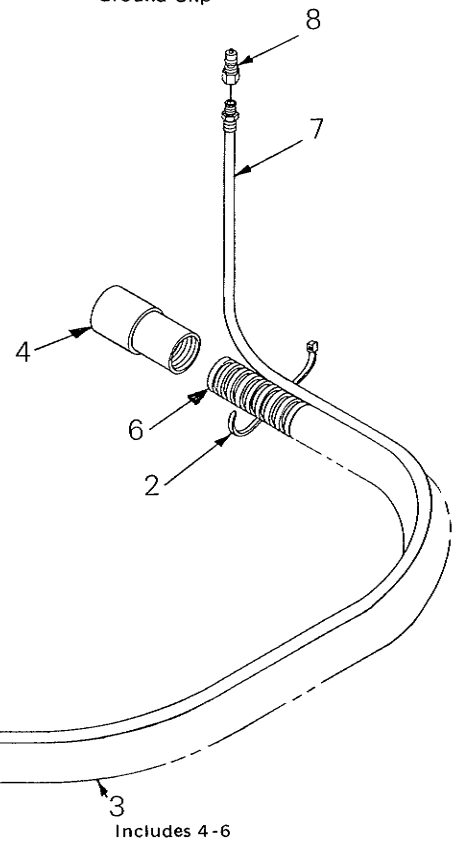
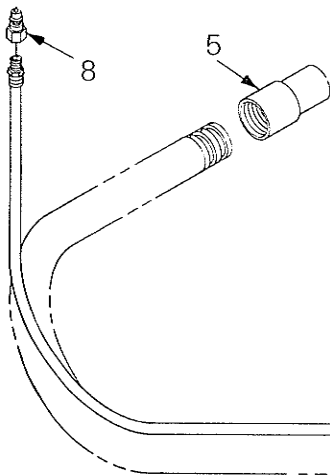

1 Includes 2-8

3 Includes 4-6

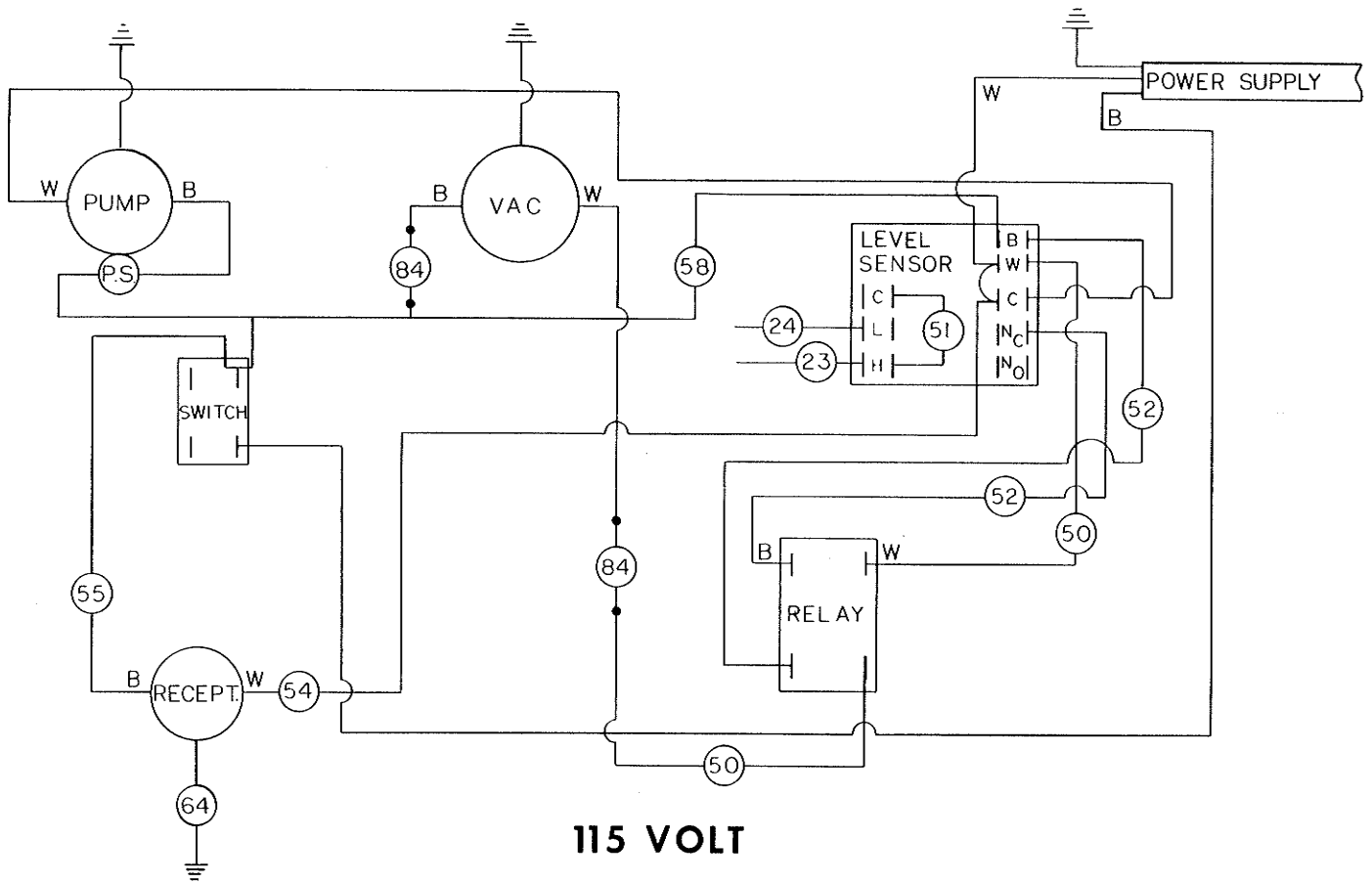

115 VOLT

"SERVICING LIQUID LEVEL SENSOR"

This machine is equipped with an electronic liquid level sensor for turning off machine when waste tank becomes full. The sensor is activated when any conductor contacts both probes. When liquid or foam in the waste tank reaches the upper probe a signal is sent to the sensor to stop the machine. Once the machine has shut off, the waste tank should be emptied. To start the machine again the vac switch must be turned off and then on again. If machine fails to start after waste tank has been emptied, dry off upper probe. If machine still fails to operate contact dealer or factory for service.