



Electronic Service Manuals

This electronic document is provided as a service to our customers. We do not create the contents of the information contained in this document. Should you have detailed questions pertaining to the information contained in this document, you may contact Michco, or the manufacturer which provided the original information in this electronic deliverable. Michco's only part in this electronic deliverable was the electronic assembly process. By providing this manual online we are not guaranteeing parts availability.

You may contact Michco through the following methods:

Phone (517) 484-9312

2011 N. High St. -- Lansing, Michigan -- 48906

Fax: (517) 484-9836

Email: CustomerService@Michco.com

Website: www.Michco.Com

Order Parts online at:

www.Michco.Com

Directly to Parts & Service:

By Email: **CustomerService@Michco.com**

By Fax: (517) 484-9836

By Voice: (517) 484-9312

Serving the Cleaning Industry Since 1922

Notice: All copyrighted material remains property of original owners, all trademarks are property of respective owners. Manuals are subject to Manufacturer's reproduction limitations. Originals or reproductions were provided by manufacturers through a request. We make no warranty as to the correctness of information provided in this document and you assume all risk. By placing these manuals on line we are not declaring our corporation to be an manufacturer authorized dealer or provider, please check our web site for authorized manufacturers we represent.



Parts Manual
Phenom Dual Motor Upright Vacuum

Table of Contents

Safety Instructions	2
Suction Body	3
Power Brush	5
Warranty	7

For Safety When Servicing or Maintaining Machine

- Disconnect the power to the machine.
- Avoid moving parts. Do not wear loose jackets, shirts, or sleeves when working on machine.
- Do not clean machine with a pressure washer.
- Authorized personnel must perform repairs and maintenance. Use Minuteman supplied replacement parts.

Suction Body

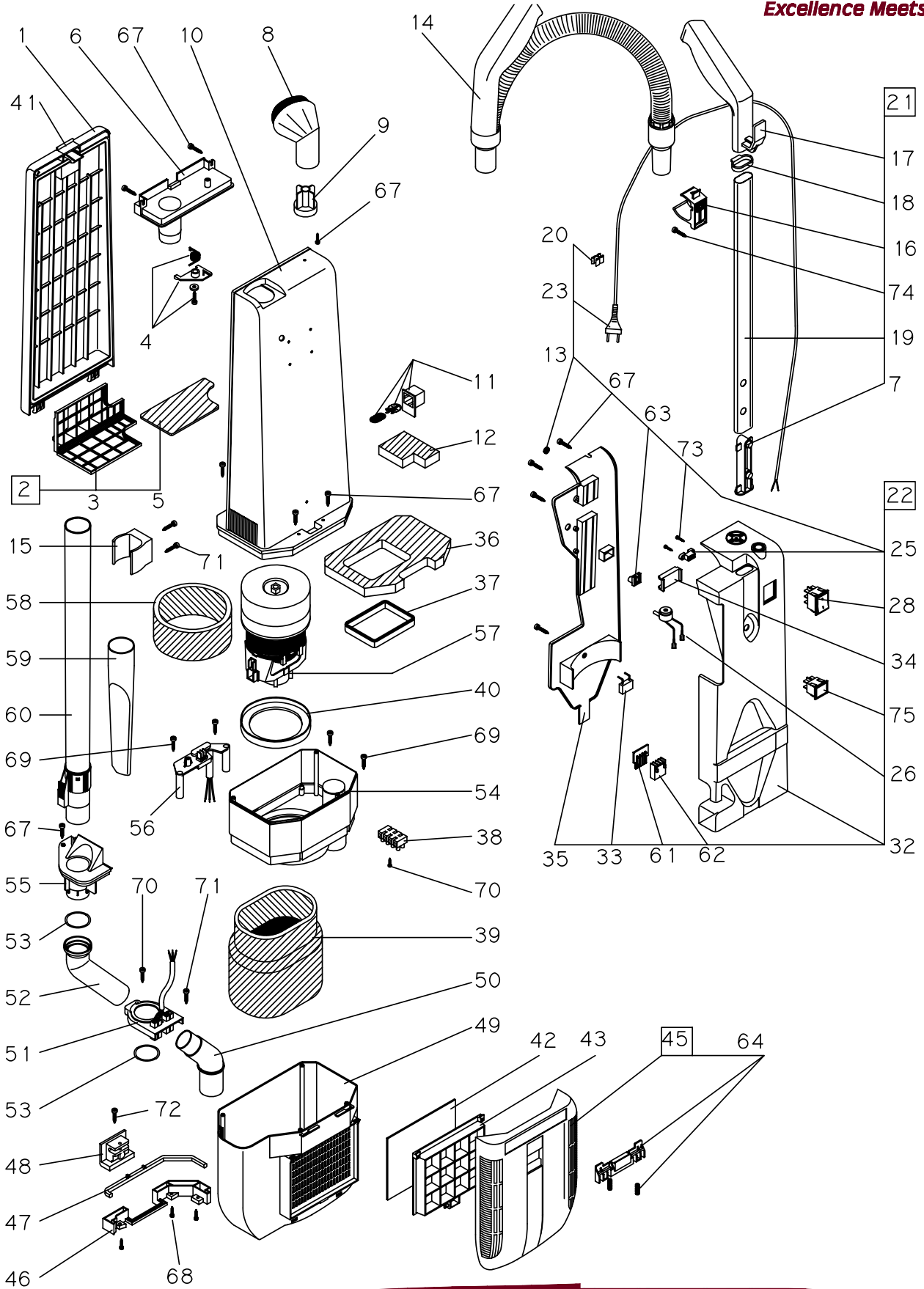

BILL OF MATERIAL - SUCTION BODY - 115V/230V

ITEM	PART NO.	DESCRIPTION	NOTES	ITEM	PART NO.	DESCRIPTION	NOTES
1	080171281	BAG HOUSING COVER DARK GREY		37	000200308	GASKET	
2	080080000	GRILL COMPLETE		38	020340400	TERMINAL BLOCK 3 POLES	
3	000160304	GRILL FILTER HOLDER		38A	020040400	TERMINAL BLOCK 2 POLES	230V MODELS ONLY
4	084580081	SAFETY SUPPORT KIT		39	011790016	FOAM MOTOR FILTER	
5	011410316	INTERNAL FILTER		40	007940308	GASKET NEW	
6	086590081	BAG ENTRANCE W/SAFETY SUPPORT		41	082721281	BAG DOOR LAT CH+SPRING DARK GREY	
7	084520081	HANDLE BUTT ON ASSEMBLY 2 POS.		42	083770081	EXHAUST MICROFILTER 5 PCS	
8	031460310	ROUND DUSTING BRUSH		43	003360100	EXHAUST GRILL	
9	002740101	ROUND DUSTING BRUSH SUPPORT		45	084384481	FRONT GRILL	
10	089631281	BAG HOUSING COMPLETE DARK GREY		46	003980133	BLOCKING JOINT PIN SUPPORT	
11	080790081	VALVE KIT		47	010840009	JOINT PIN	
12	011050016	VALVE FILTER		48	001500105	CONTROL PIN SLIDE	
13	010260307	O-RING		49	003961201	VACUUM MOTOR HOUSING	
14	086670381	EXTENSION HOSE WITH HANDLE GRIP		50	001760331	LOWER CURVE	
15	000980310	WAND CLIP		51	084610080	CURVE SUPPORT V.120/60 3 WRES	
16	001950110	UPPER HOOK FOR FLEXIBLE HOSE		51A	084610081	CURVE SUPPORT V.100-230-240/50 For RX Hepa	230V MODELS ONLY
17	080771281	HANDLE GRIP DARK GREY		52	001750331	UPPER CURVE	
18	002870105	RETAINER		53	010270307	O RING	
19	084590081	CHROMATE TUBE		54	081201281	INNER VACUUM MOTOR HOUSING	
20A	001680304	CORD CLIP V.230/240	230V MODELS ONLY	55	003970133	HOSE INLET RX Hepa	
21	084411281	HANDLE TUBE ASSEMBLY 2 POS.		56	088660080	CORD CLAMP W/OUT ELECT. 3 WRES NEW	
22	084334480	ELECTRICAL SYSTEM ASSY		56A	088650080	CORD CLAMP W/OUT ELECT. 2 WRES V.100/120/230/240	230V MODELS ONLY
22A	180454481	ELECTRICAL SYSTEM ASSY SCHUKO PLUG	230V MODELS ONLY	57	051350080	VACUUM MOTOR R26APSS (HE) V.120/60 W.750	
22B	180464481	ELECTRICAL SYSTEM ASSY BRITISH PLUG	230V MODELS ONLY	57A	051340081	VACUUM MOTOR R26APSS (HE) V.240/50 W.750	230V MODELS ONLY
22C	180474481	ELECTRICAL SYSTEM ASSY SWISS PLUG	230V MODELS ONLY	58	010220016	FOAM FILTER	
22D	180484481	ELECTRICAL SYSTEM ASSY CHINA PLUG	230V MODELS ONLY	59	030060310	CREVICE TOOL	
22E	180494481	ELECTRICAL SYSTEM ASSY KOREA PLUG	230V MODELS ONLY	60	030550300	TELESCOPIC WAND	
22F	180504481	ELECTRICAL SYSTEM ASSY AUSTRALIAN PLUG	230V MODELS ONLY	61	002480003	CONTACT COVER 4 POS.	
23	022480020	CORD 3x18 12.5 MT. USA PLUG YELLOW		62	002400003	CONTACT HOUSING 4 POS.	
23A	020200312	CORD.2x1 SCHUKO PLUG	230V MODELS ONLY	63	003230001	VACUUM SENSOR ADAPTOR	
23B	020780312	CORD.2x1 UK PLUG	230V MODELS ONLY	64	084440181	BOTTOM COVER KIT MEDIUM GREY	
23C	020990312	CORD 2x1 SWISS PLUG	230V MODELS ONLY	67	087250009	WRAPPING OF 20 PCS SCREW 3,5x22	
23D	023670312	CORD.2x1 10 MT. CHINA PLUG	230V MODELS ONLY	68	088020009	WRAPPING OF 20 PCS SCREW 3,5x13	
23E	024080312	CORD.2x1 KOREA PLUG	230V MODELS ONLY	69	085550009	WRAPPING OF 20 PCS SCREW 3,5x25	
23F	021300312	CORD 2x1 AUSTRALIAN PLUG	230V MODELS ONLY	70	086440009	WRAPPING OF 20 PCS SCREW 3,5x19	
25	000070305	CORD CLAMP		71	085590009	WRAPPING OF 20 PCS SCREW 3,9x13	
26	021340000	NEW VACUUM SENSOR		72	087260009	WRAPPING OF 20 PCS SCREW 3,9x22	
28	020390300	MAIN SWITCH V.100/120/230/240 15A		73	085610009	WRAPPING OF 20 PCS SCREW 2,9x16	
32	003934401	COVER HANDLE		74	085560009	WRAPPING OF 20 PCS SCREW 3,9x16	
33A	020120000	RFI FILTER V.230	230V MODELS ONLY	75	020020000	INDICATOR LIGHT	
34	001980306	COMB WIRE HOLDER		022290000		CARBON BRUSH R26 (NEW)	
35	003924401	FRAME HANDLE		030640000		HEPA FILTER	
36	010200016	FOAM FILTER		030650000		CARBON ACTIVE FILTER	

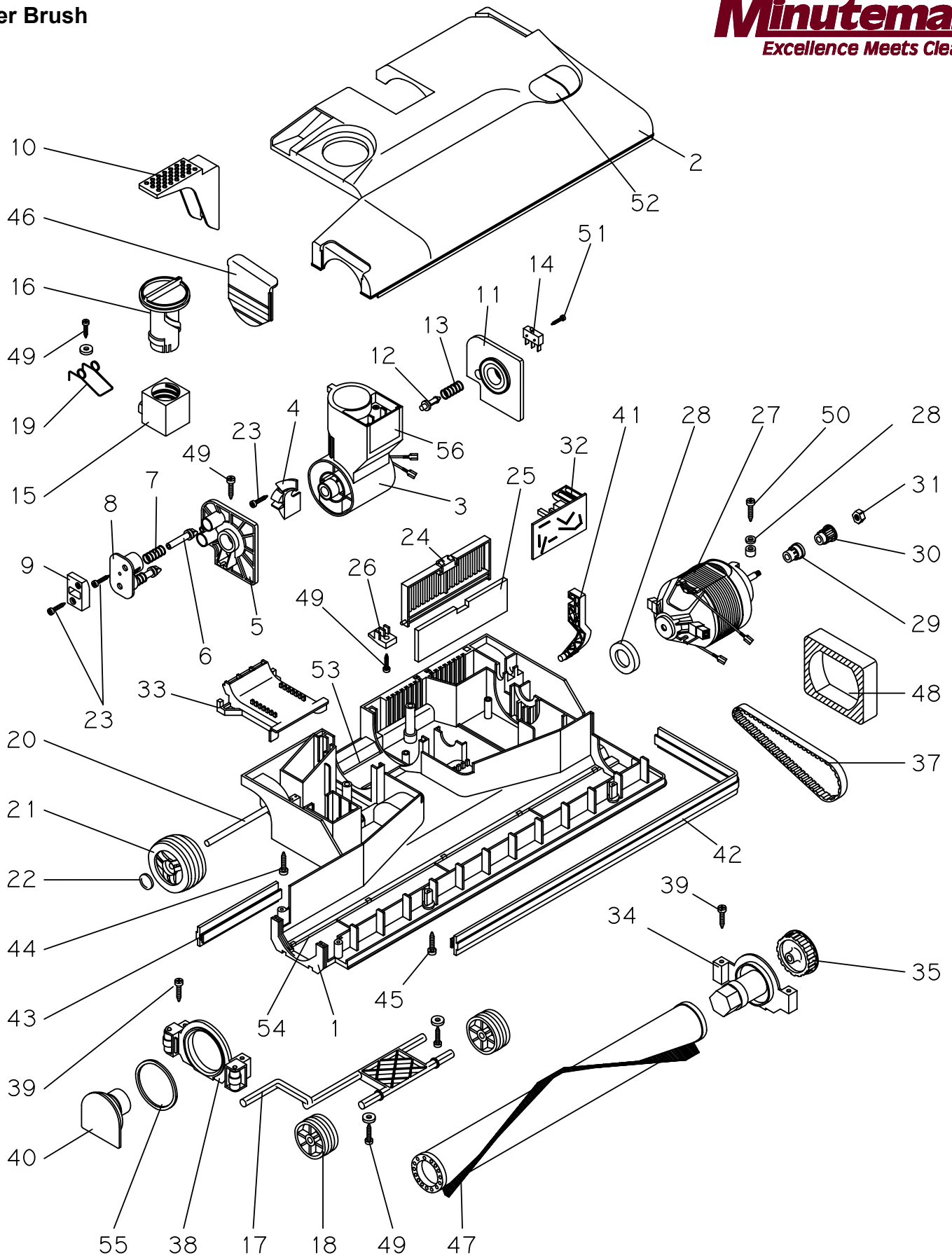

BILL OF MATERIAL - POWER BRUSH 15" & 18" - 115V/230V							
ITEM	PART NO.	DESCRIPTION	NOTES	ITEM	PART NO.	DESCRIPTION	NOTES
1	081990281	BODY MAIN BRUSH HEAD 15"	15" ONLY	29	002890029	SPACER PINION	
	082850281	BODY MAIN BRUSH HEAD 18"	18" ONLY	30	002880029	PINION	
2	082861281	ELECTRIC BRUSH COVER 15"	15" ONLY	31	180160009	WRAPPING OF 20 PCS NUT M4	
	082871281	ELECTRIC BRUSH COVER 18"	18" ONLY	32	020810000	CIRCUIT BOARD 120V	
3	083210380	JOINT COMPLETE 120V 3 way		32A	020840000	CIRCUIT BOARD 230/240V	230V MODELS ONLY
3A	082030381	JOINT COMPLETE 100/120/240V	230V MODELS ONLY	33	002170104	CHANEL COVER	
4	002290305	JOINT PIN SLIDE		34	082600081	TRANSMISSION SUPPORT W/ PULLEY	
5	081910080	SUPPORT RIGHT JOINT		35	086160381	PULLEY WITH METAL INSERT	
6	001940036	PLUNGER		37	010790300	TIMING BELT 7 MM	
7	010390009	SPRING DOWEL RELEASE		38	081940081	WHEELS SUPPORT	
8	001930036	DOUBLE PIN WASHER		39	085560009	WRAPPING OF 20 PCS SCREW 3,9x16	
9	002180105	DOUBLE RELEASE PLATE		40	081950081	ROLLER SUPPORT	
10	002550105	FOOT PEDAL		41	002210304	SIDE LEVER	
11	081920080	SUPPORT LEFT JOINT		42	002560112	FRONT BUMPER 15"	15" ONLY
12	000670036	SWITCH ACTIVATOR PIN			002580112	FRONT BUMPER 18"	18" ONLY
13	010480009	SPRING		43	002570112	BACK BUMPER GASKET 15"	15" ONLY
14	020640000	MICROSWITCH			002590112	BACK BUMPER GASKET 18"	18" ONLY
15	000990305	BRUSH ADJUSTER		44	087270009	WRAPPING OF 20 PCS SCREW 4,8x50	
16	002424404	BRUSH ADJUSTER KNOB		45	087280009	WRAPPING OF 20 PCS SCREW 3,5x38	
17	011330029	FRONT AXLE		46	002150104	SIDE COVER	
18	003090004	FRONT WHEEL-NYLON SILVER GREY		47	003200301	BRUSH ROLLER 15"	15" ONLY
19	011160009	SPRING BRUSH ADJUST			003250301	BRUSH ROLLER 18"	18" ONLY
20	011390009	SHAFT FOR FIXED WHEELS		48	010580016	MOTOR FILTER	
21	002270000	BIG WHEEL		49	085590009	WRAPPING OF 20 PCS SCREW 3,9x13	
22	012840009	WHEEL RETAINER NEW		50	085550009	WRAPPING OF 20 PCS SCREW 3,5x25	
23	085610009	WRAPPING OF 20 PCS SCREW 2,9x16		51	086950009	WRAPPING OF 20 PCS SCREW 2,2x16	
24	002140104	FILTER GRILL		52	082940081	LENS SET RED & GREEN	
25	011240316	EXHAUST FILTER		53	011000017	FELT FOR BRUSH HOUSING	
26	002160104	STOP GRILL PLATE		54	082890000	BASE METAL GUIDES SET 15"	15" ONLY
27	050030080	BRUSH MOTOR 100/120V (15")	15" 115V MODEL ONLY		082900000	BASE METAL GUIDES SET 18"	18" ONLY
	050240080	BRUSH MOTOR 100/120V (18")	18" 115V MODEL ONLY	55	011360307	O'RING	
27A	050040081	BRUSH MOTOR 240V 380 (14")	15" 230V MODEL ONLY	56	082490080	MALE ELEC. CONNECTION SET 120V 3 WIRES	
	050250081	BRUSH MOTOR 240V (16"-18")	18" 230V MODEL ONLY	56A	082490081	MALE ELEC. CONNECTION SET 100/230/240V	230V MODELS ONLY
28		ONLY EUROPE			021260000	CARBON BRUSH FOR BRUSH MOTOR R73	

REVISION G EFFECTIVE 12/1/2011

Minuteman International, Inc. warrants to the original purchaser/user that the product is free from defects in workmanship and materials under normal use. Minuteman will, at its option, repair or replace without charge, parts that fail under normal use and service when operated and maintained in accordance with the applicable operation and instruction manuals. All warranty claims must be submitted through and approved by factory authorized repair stations.

This warranty does not apply to normal wear, or to items whose life is dependent on their use and care, such as belts, cords, switches, hoses, rubber parts, electrical motor components or adjustments. Parts manufactured by Minuteman are covered by and subject to the warranties and/or guarantees of their manufacturers. Please contact Minuteman for procedures in warranty claims against these manufacturers.

Special warning to purchaser — Use of replacement filters and/or prefilters not manufactured by Minuteman or its designated licensees, will void all warranties expressed or implied. A potential health hazard exists without original equipment replacement.

All warranted items become the sole property of Minuteman or its original manufacturer, whichever the case may be.

Minuteman disclaims any implied warranty, including the warranty of merchantability and the warranty of fitness for a particular purpose. Minuteman assumes no responsibility for any special, incidental or consequential damages.

This limited warranty is applicable only in the U.S.A. and Canada, and is extended only to the original user/purchaser of this product. Customers outside the U.S.A. and Canada should contact their local distributor for export warranty policies. Minuteman is not responsible for costs or repairs performed by persons other than those specifically authorized by Minuteman. This warranty does not apply to damage from transportation, alterations by unauthorized persons, misuse or abuse of the equipment, use of non-compatible chemicals, or damage to property, or loss of income due to malfunctions of the product.

If a difficulty develops with this machine, you should contact the dealer from whom it was purchased.

This warranty gives you specific legal rights, and you may have other rights which vary from state to state. Some states do not allow the exclusion or limitation of special, incidental or consequential damages, or limitations on how long an implied warranty lasts, so the above exclusions and limitations may not apply to you.

Cord Electric Group: Three years parts, two years labor, ninety days travel (Not to exceed two hours)

Exceptions.....

Model	Parts	Labor	Poly	Travel
Port A Scrub	1 yr	6 months	10 yrs	0
MPV 13	1 yr	0	0	0
MPV 14 & 18	2 yrs	1 yr	0	0
Phenom Upright Vacuums	1 yr	1yr	0	0
Rapid Air Blower	1 yr	1 yr	10 yrs	0
Explosion Proof Vacuum	1 yr	1 yr	0	0
X12, X12H & TRS 14	1 yr	1 yr	10 yrs	0
E17 & E20 Electric Scrubbers	1 yr	6 months	10 yrs	0
Pneumatic Vacuums	3 yr	1 yr	0	0

Description	Parts	Labor	Poly	Travel
Battery Operated Group	3 yrs	2 yrs	10	90 days
Sweepers	1 yr	1 yr	10	90 days
Internal Combustion Group	1 yr	1 yr	10	90 days

Exception: PAS 14B 1 yr 1 yr 10 yr 0

Battery Chargers: One year replacement
 Replacement Parts: Ninety days
 Batteries: 0-3 months replacement, 4-12 months pro-rate
 Polyethylene Plastic Tanks: Tanks have 10yr warranty, no additional labor