



Electronic Service Manuals

This electronic document is provided as a service to our customers. We do not create the contents of the information contained in this document. Should you have detailed questions pertaining to the information contained in this document, you may contact Michco, or the manufacturer which provided the original information in this electronic deliverable. Michco's only part in this electronic deliverable was the electronic assembly process. By providing this manual on line we are not guaranteeing parts availability.

You may contact Michco through the following methods:

Phone (517) 484-9312 or (800) 331-3339

2011 N. High St. -- Lansing, Michigan -- 48906

Fax: (517) 484-9836

Email: CustServe@Michco.com

Web site: www.Michco.Com

Parts Web site: www.FloorMachineParts.Com

Order Parts on Line at:

www.FloorMachineParts.Com

Directly to Parts & Service:

By Email: **Shop@Michco.com**

By Fax: (517) 702-2041

By Voice: Use numbers above.

Serving the Cleaning Industry Since 1922

Notice: All copyrighted material remains property of original owners, all trademarks are property of respective owners. Manuals are subject to Manufacturer's reproduction limitations. Originals or reproductions were provided by manufacturers through a request. We make no warranty as to the correctness of information provided in this document and you assume all risk. By placing these manuals on line we are not declaring our corporation to be an manufacturer authorized dealer or provider, please check our web site for authorized manufacturers we represent.

**700 Series
Industrial Air
Operated Vacuum**

**Model:
C70555
C70155
C70255
C70455**

OPERATION

SERVICE

PARTS

CARE

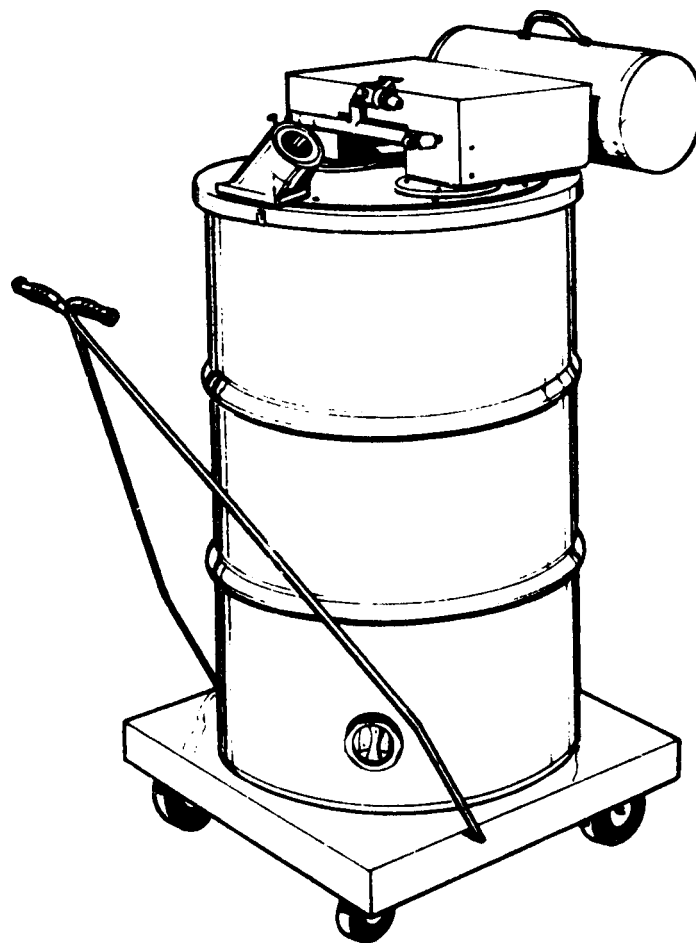

Revised 9/97

Minuteman[®]

MODELS 701, 702 AND 704, 705, AIR OPERATED WET/DRY VACUUMS

OPERATING INSTRUCTIONS

INSPECTION

Carefully unpack and inspect your machine for shipping damage. Each unit is tested and thoroughly inspected before shipment, therefore, any damage is the responsibility of the delivering carrier who should be notified. Read all instructions carefully before operating.

SPECIAL WARNING

Air operated equipment can generate static electricity during use. Static dissipating arcing can be generated and occur if equipment and accessories are not grounded. Risk of explosion is possible if operated near explosive materials or vapors. Do not operate this equipment near flammable materials such as solvents, thinners, fuels, grain dust, etc.

AIR PRESSURE AND C.F.M. VOLUME REQUIRED

For maximum performance, operate with requirements listed below:

<u>Model</u>	<u>Air Supply Line</u>	<u>Maximum Pressure</u>	<u>C.F.M.</u>
701 & 705	1/2"	100	46
702	3/4"	100	91
704	1"	100	182

Air pressure control valve can be regulated to operate with lower pressure and C.F.M. when maximum is not required. OPTIONAL: Air pressure regulator can be attached at air valve for positive air pressure and C.F.M. control.

ASSEMBLY PROCEDURE FOR MODELS 701, 702 AND 704 WET/DRY VACUUMS

1. For wet recovery, attach float assembly #515003, page 6, to underside of vacuum lid with #710359 screw and washer #711543 provided.
2. For dry recovery, attach filter bag assembly #805024, page 7, to underside of vacuum lid. Float assembly already attached does not have to be removed. To attach filter, remove nuts attached to studs on underside of lid. Squeeze to remove. Locate filter frame onto studs and apply lock nuts. Lock nuts must be hand tightened to insure positive filter bag seal to underside of vacuum lid.

Always remove the filter bag assembly when vacuum is used for wet recovery.

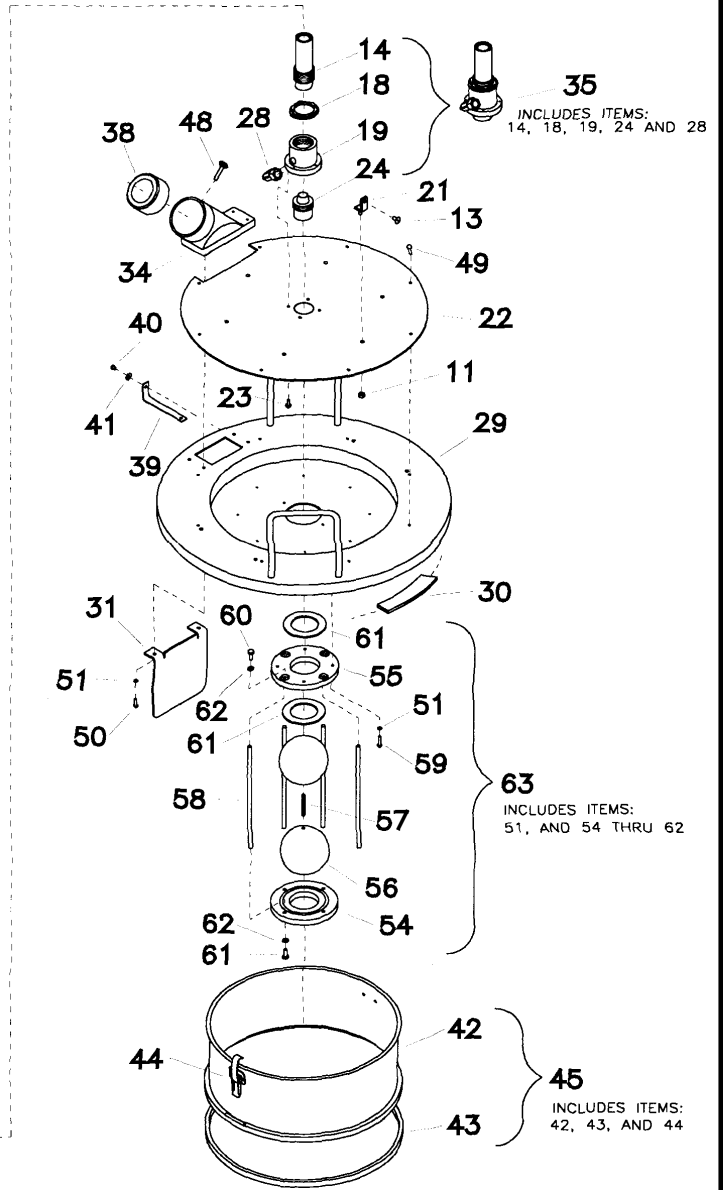
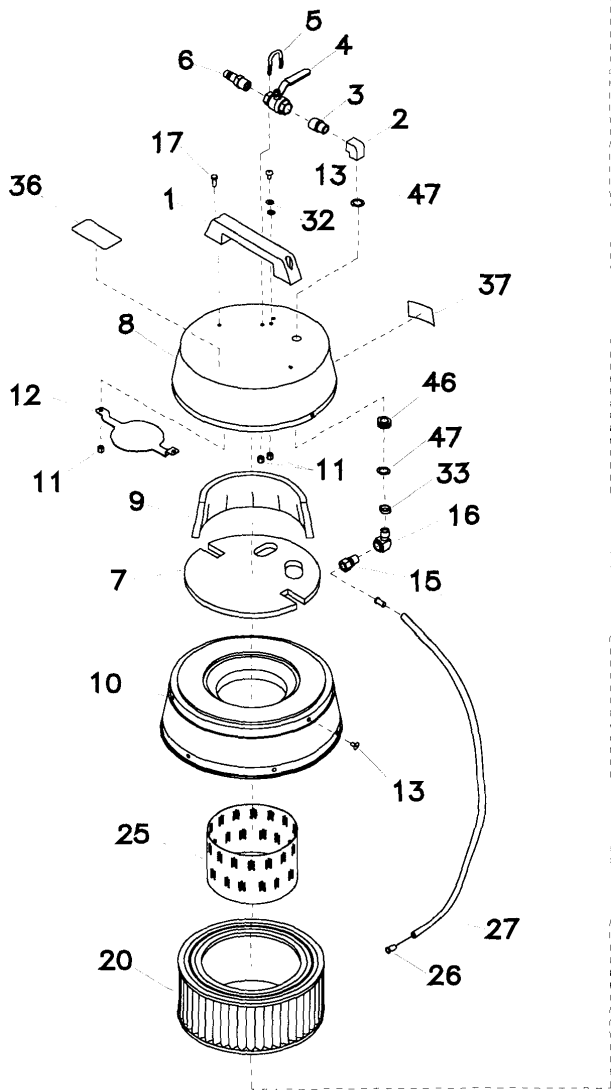

Parts List

ITEM NO.	PART NO.	QUANTITY	DESCRIPTION
1	460000	1	Handle
2	700028	1	3/8 x 3/8 Brass Elbow
3	420017	1	Hex Nipple Reducer
4	701009	1	.50 Valve
5	712105	1	U-Bolt
6	701010	1	.50 Coupler
7	700018	1	Dome Felt
8	700022PTD	1	Top Cover
9	700016	1	Felt Liner
10	700023PTD	1	Filter Cover
11	712667	15	¼-20 SS Nyloc Nut
12	700019	1	Air Deflector
13	710178	10	¼-20 x .50 SCR-MC STPL
14	700012	1	Venturi Exhaust Tube
15	420008	1	Male Connector
16	830062	1	3/8 x 3/8 Brass ST90
17	711204	2	BLT-HH ¼-20 x .75 STPL
18	700014	1	Locking Nut
19	700011	1	Venturi Housing
20	700026	1	Exhaust Filter
21	832106	6	Bracket Mounting Tab
22	700051	1	Base Lid Cover
23	712534	4	SCR-MC 10-24 x .50 SS
24	700013	1	Venturi Intake
25	700017	1	Perforated Shield
26	420011	2	Brass Insert
27	700021	1	Poly Hose 32" Long
28	420009	1	Male Elbow 469F
29	252003	1	Lid Weldment w/Handles
30	806006MCH	1	Lid Gasket
31	760159	1	Splash Guard
32	711505	2	WSR-Flat ¼
33	829285PLT	1	Spacer - Zinc Plated
34	760008PLT	1	Intake Painted
35	700010	1	Venturi Assembly
36	715003	1	Decal, Air Pressure
37	715029	1	Decal, Serial Name Plate
38	900056	1	Adapter Intake
39	701204	1	Braided Ground Strap
40	710352	1	SCR-MC 10-32 x .25
41	711503	2	WSR-Flat #10
42	760033	1	Splash Shield - No Hardware
43	760165	1	Edging
44	761054	2	Latch
45	750326	1	Splash Shield - Complete
46	260274	1	Grommet
47	711513	2	WSR-Flat .69 x 1.06 x .029 SS
48	712016	1	SCR-Thumb 1/4-20 x 1.25
49	711109	8	SCR-ST-B 12 x .50
50	710255	4	SCR-MC 10-32 x .62
51	711543	5	WSR-Helical #10
52	710331	8	SCR-MC 8-32 x .75
53	711542	8	WSR-Helical #8
54	701041	1	Plate, Water Shut-Off
55	701042	1	Plate, Water Shut-Off
56	701016	2	Ball, Float 4" Dia.
57	701013	1	Stud ¼-20 x 2
58	701012	4	Rod, Spacer
59	710359	2	SCR-MC 10-32 x .87
60	711203	8	BLT-HH ¼-20 x .62
61	701015	2	Gasket, 2.25 x 3.50 x .12
62	711544	8	WSR-Helical ¼
63	515003	1	Float Assembly - Complete

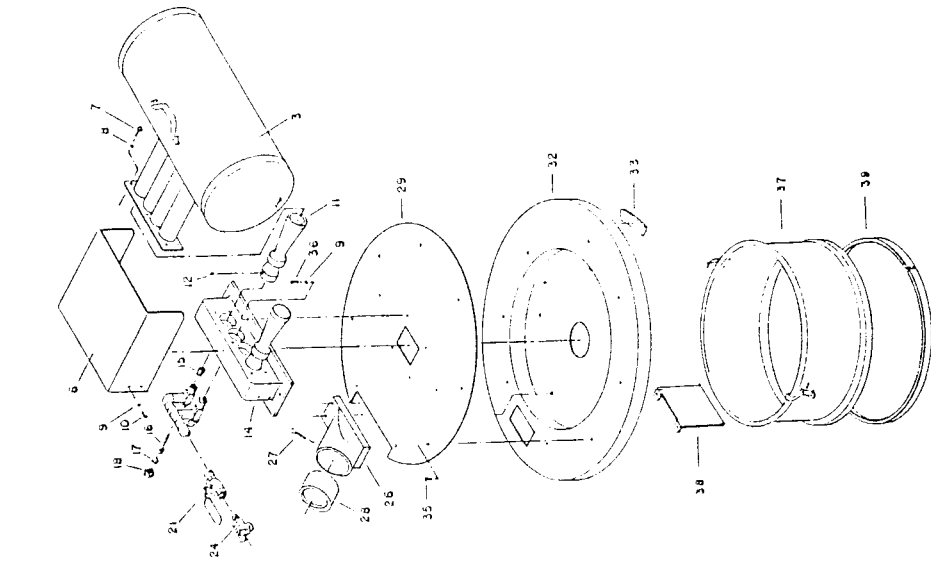

704 - 704111

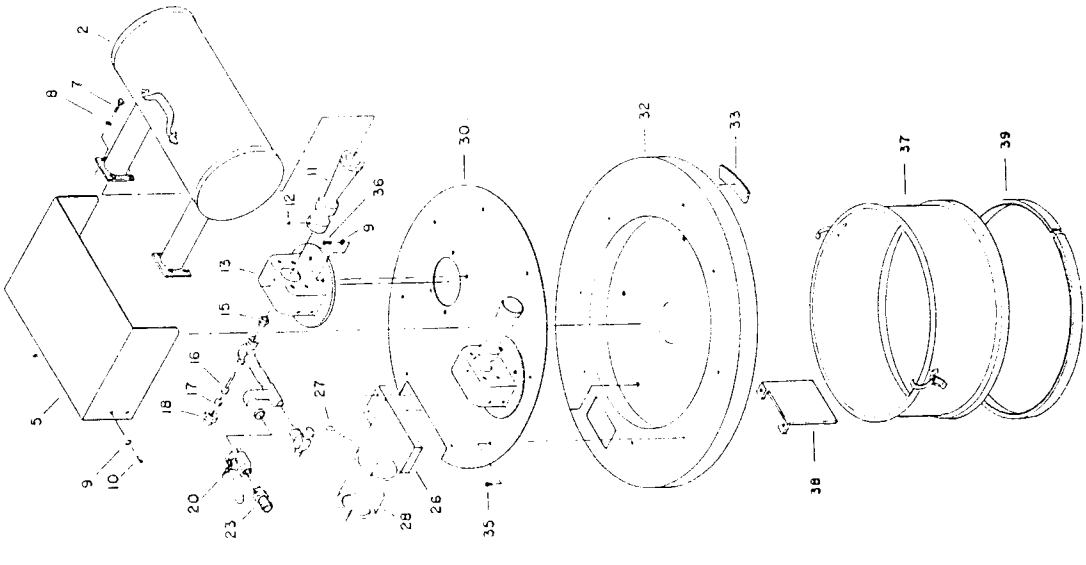

702 - 702111

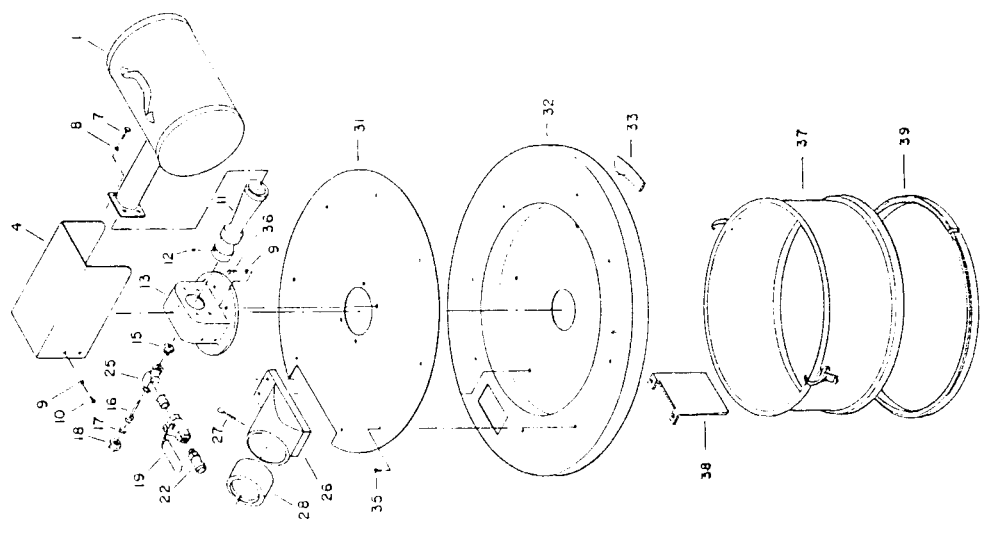

701 - 701111

Parts Listing

ITEM NO.	PART NO.	QUANTITY	DESCRIPTION
1	701033	1	Muffler, 701
2	702021	1	Muffler, 702
3	704017	1	Muffler, 704
4	760998	1	Cover, 701
5	702023	1	Cover, 702
6	704020	1	Cover, 704
7	711229	4	BLT-HH 5/16-18 x 7/8
8	711545	4	WSR-LOC 5/16
9	710353	4	SCR-MC 10/32 x 3/8
10	711543	4	WSR-LOC #10
11	701006MCH	As required	Venturi horn
12	711005	As required	SCR-ST 1/4-20 x 5/16
13	701005MCH	1	Venturi housing 701-702
14	760009MCH	1	Venturi housing 704
15	701029	As required	Office
16	750641	As required	Needle assy.
17	711010	As required	Set screw
18	711357	As required	Nut-acrown 5/8 x 11
19	701009	1	Air valve 1/2 701
20	702002	1	Air valve 3/4 702
21	704005	1	Air valve 1 704
22	701010	1	Coupler 701
23	702003	1	Coupler 702
24	704008	1	Coupler 704
25	702001	1	Valve body assy. 702-704
25A	701007	1	Valve body assy. 701
26	760008PTD	1	Intake
27	712016	1	Thumb screw
28	900056	1	Adapter
29	760011PTD	1	Lid cover 701-704
30	762214PTD	1	Lid cover 702
31	760011PTD	1	Lid cover 701-704
32	760010PTD	1	Lid 55 gallon common
33	806006MCH	1	Gasket
35	711109	8	SCR-self tap #12 x 1/2
36	710356	5	SCR-MC 10-32 x 5/8
37	750326	1	Splash shield, includes Item #39
38	760159	1	Deflector
39	760165	1	Edging

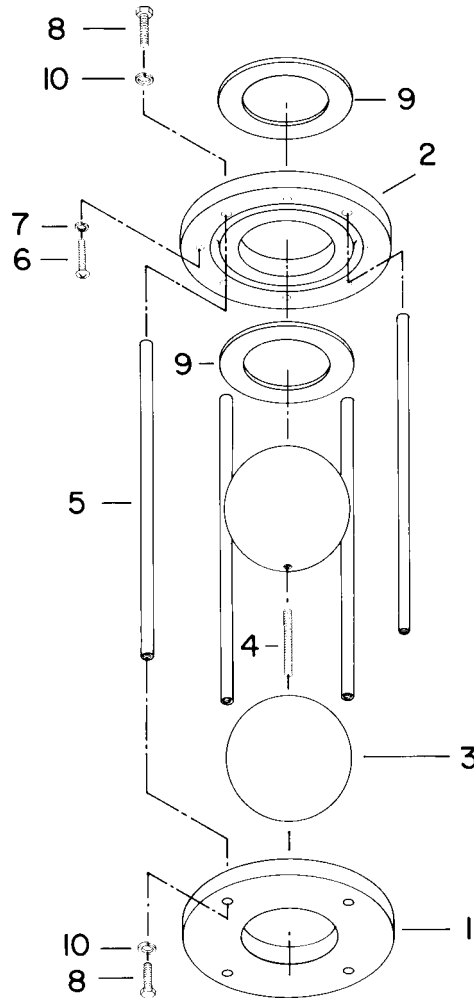

Parts Listing

ITEM NO.	PART NO.	QUANTITY	DESCRIPTION
1	701041	1	Plate, end cap water shut
2	701042	1	Plate, end cap water shut
3	701016	2	Ball, float 4 dia.
4	701013	1	Stud
5	701012	4	Rod, spacer
6	710359	2	SCR-MC 10-32 x .87 SS
7	711543	2	WSR, Helical SPR LOC #10
8	711203	8	BLT, HH 1/4-20 x .62
9	701015	2	Gasket, 2.25 x 3.50 x .12
10	711544	8	WSR, Helical SPR LOC 1/4
****	515003		Float asy complete

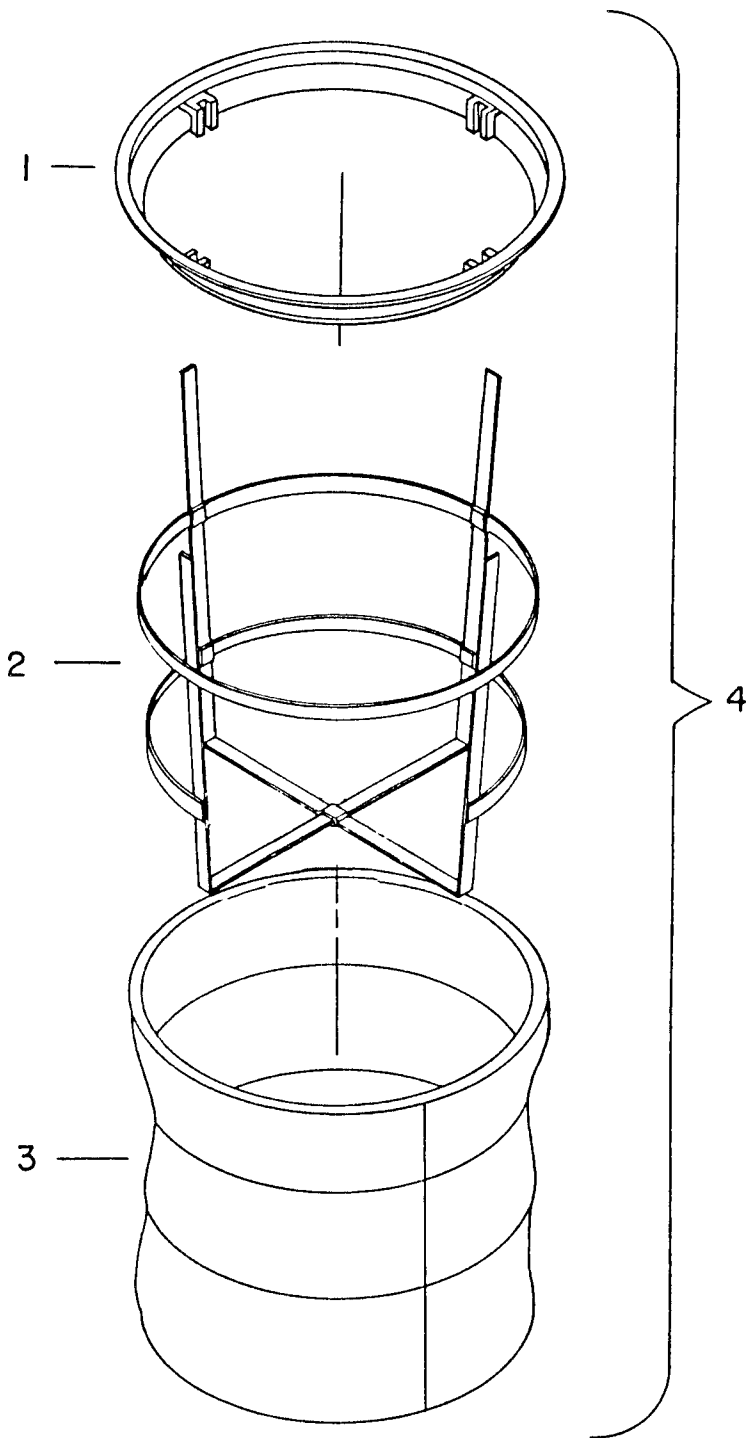

ITEM NO.	PART NO.	QTY	DESCRIPTION
1	760131	1	Molded bag ring
2	750097	1	Bag frame
3	805054	1	Cloth bag only
4	805057	1	Bag asy. complete

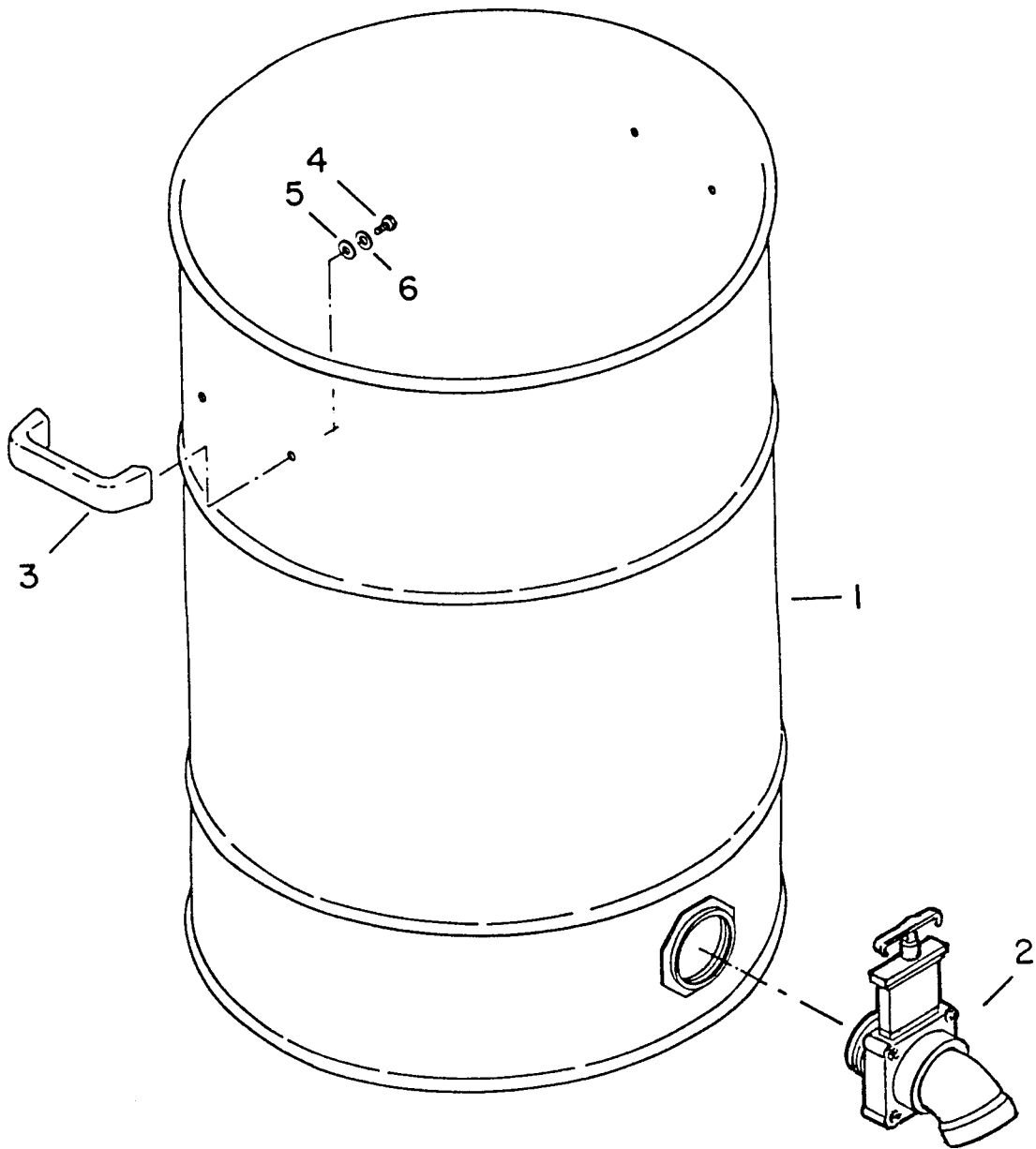

PARTS LIST

Item	Part No.	Qty	Description
1	900078PTD	1	Tank 30 Gal. PTD Less Handles
1a	900015PTD	1	Tank 55 Gal. PTD No Handles
2	900047	1	Dump Valve
3	900031POL	2	Handle, Tank Polished
4	711203	4	BLT, HH 1/4-20 x .62
5	711591	4	Washer, Rubber
6	711505	4	WSR, Flat 1/4
***	C90007-80		Tank 30 Gal. Complete
***	805037PKG		Drum Liner 30 Gal. Pkg. 12
***	805046PKG		Drum Liner 55 Gal. Pkg. 12

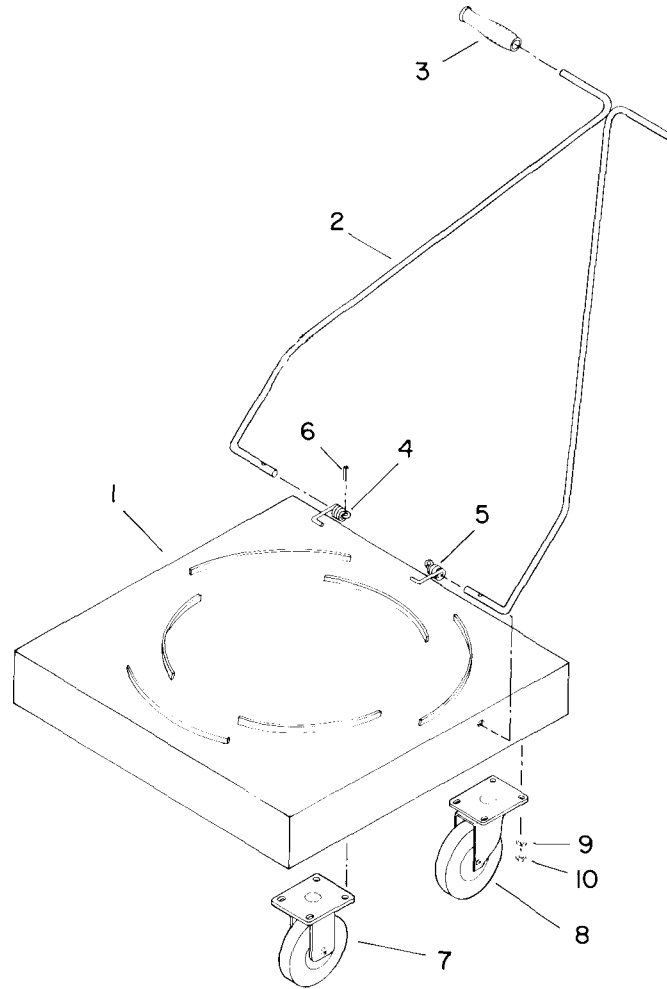

Parts Listings

ITEM NO.	PART NO.	QUANTITY	DESCRIPTION
1	750045	1	Weldment dolly 30/55
2	900051	1	Weldment, handle
3	900052	2	Grip, handle
4	900080	1	Spring, torsion RH
5	900081	1	Spring LH
6	711642	2	Rollpin
7	761050	2	Caster, rigid 5"
8	761049	2	Caster, swivel 5"
9	711545	16	WSR, helical Spr Loc 5/16
10	711319	16	Nut-Hex 5/16-18 ST PL
****	900048		Dolly cart complete

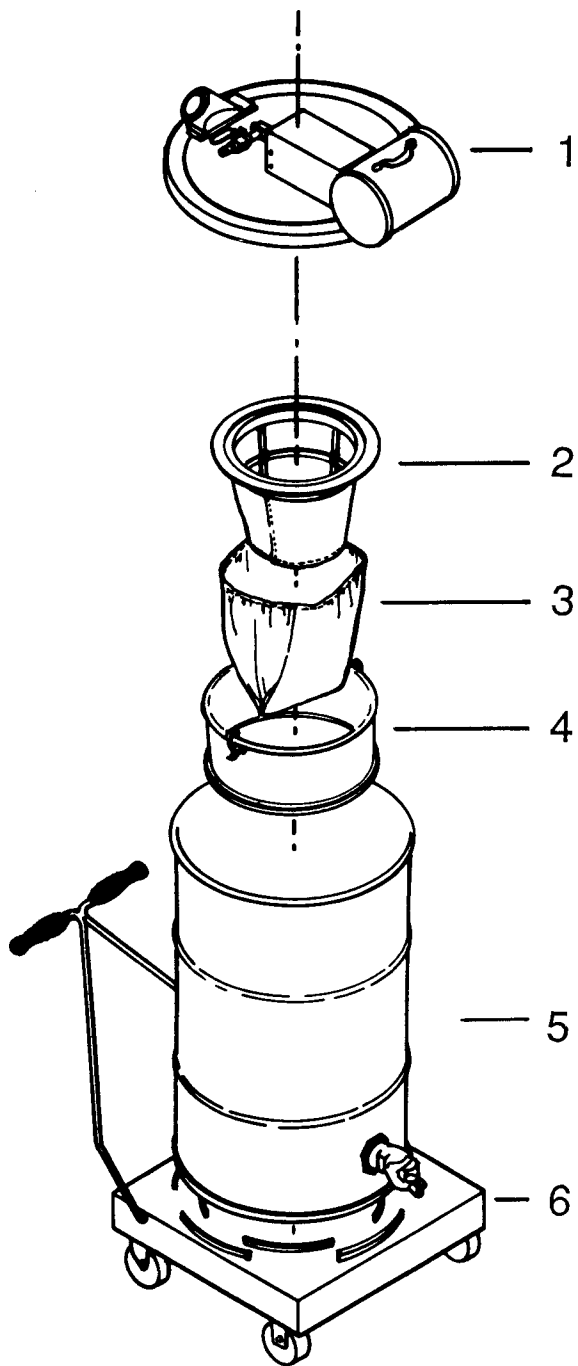

FIG. 1

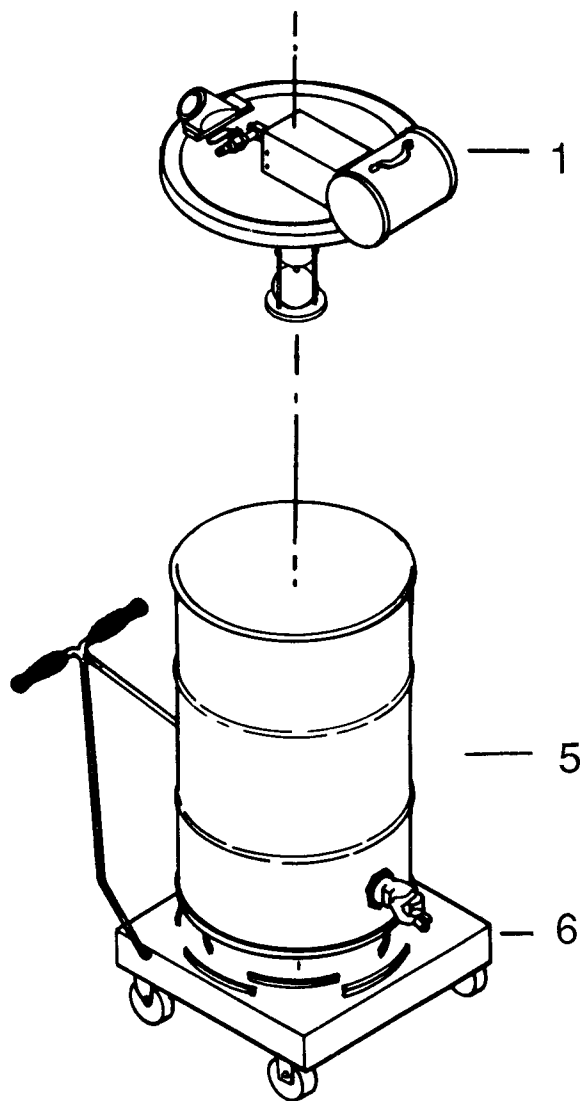

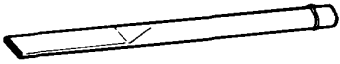
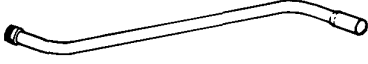
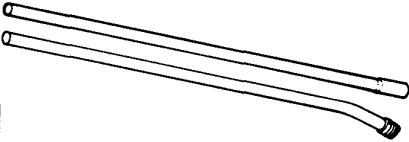
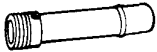

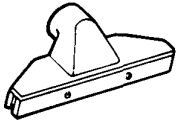
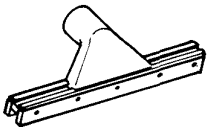
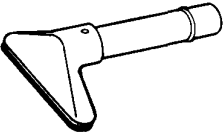
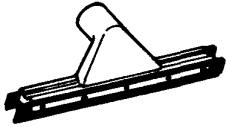

FIG. 2

OPTIONAL INDUSTRIAL TOOLS AND ACCESSORIES

A		<p>800024 800022 800023 800175MCH 800176MCH 800025</p>	<p>3" Rd Dust Brush Complete 5" Rd Dust Brush Complete Bristle Insert 5" Dust Brush HSG 5" Dust Brush HSG 3" Bristle Insert 3"</p>
B		<p>800034</p>	<p>24" Crev Tool Aluminum, Complete</p>
C		<p>800015</p>	<p>Wand Asy 1-1/2, Complete</p>
D		<p>800017 800064 800019</p>	<p>Set Tube, High-up 10' 5' Tube Lower Section 5' Section Upper</p>
E		<p>800116</p>	<p>Swivel, Hose End Exp, Complete</p>
F		<p>801010</p>	<p>Hose Asy 1-1/2 x 10'</p>
G		<p>800032 711006 800033 800193POL</p>	<p>6" Curved Pipe Tool, Complete Set Screw Bristl Insert Curved 6" 6" Curved Pipe Tool</p>
H		<p>800072 710356 710357 800187PTD 800217 800218</p>	<p>12" Gulper Tool, Complete SCR-MC 10-32 x .62 SCR-MC 10-32 x .75 Gulper Nozzle Fibre Shoe Rear Fibre Shoe Front</p>
I		<p>800108 710530 800003MCH 800178PTD</p>	<p>14" Fibre Tool Complete Screw 8/32 x 1/2 Brass Fibre Shod Tool Casting</p>
J		<p>800038 800029</p>	<p>6" Tool W/Handle Tube, Complete Bristle Insert Replacement</p>
K		<p>800109 710330 800121 800178PTD 800239 800240</p>	<p>14" Squeege, Complete SCR-SC 8-32 x .62 14" Retaining Strip Casting, Tool MCH Blade Squeege Wide Blade Squeege Narrow</p>

LIMITED WARRANTY

Minuteman International, Inc. warrants to the original purchaser/user that this product is free from defects in workmanship and materials under normal use and service for a period of three years from date of purchase. In addition, Minuteman International, Inc. will, at its option, honor labor warranty claims for the first 12 months from date of sale, provided such claims are submitted through and approved by factory authorized repair stations. Minuteman International, Inc. will, at its option, repair or replace without charge, except for transportation costs, parts that fail under normal use and service when operated and maintained in accordance with the applicable operation and instruction manuals.

This warranty does not apply to normal wear, or to items whose life is dependent on their use and care, such as belts, cords, switches, hoses, rubber parts, electrical motor components or adjustments. Parts not manufactured by Minuteman International, Inc. such as engines, batteries, battery chargers, hydraulic pumps, and tires are covered by and subject to the warranties and/or guarantees of their manufacturers. Please contact Minuteman International, Inc. for procedures in warranty claims against these manufacturers.

Special warning to purchaser — Use of replacement filters and/or prefilters not manufactured by Minuteman International, Inc. or its designated licensees, will void all warranties expressed or implied.

A potential health hazard exists without exact original equipment replacement.

All warranted items become the sole property of Minuteman International, Inc. or its original manufacturer, whichever the case may be.

Minuteman International, Inc. disclaims any implied warranty, including the warranty of merchantability and the warranty of fitness for a particular purpose. Minuteman International, Inc. assumes no responsibility for any special, incidental or consequential damages.

This limited warranty is applicable only in the U.S.A. and Canada, and is extended only to the original user/purchaser of this product. Customers outside the U.S.A. and Canada should contact their local distributor for export warranty policies. Minuteman International, Inc. is not responsible for costs or repairs performed by persons other than those specifically authorized by Minuteman International, Inc. This warranty does not apply to damage from transportation, alterations by unauthorized persons, misuse or abuse of the equipment, use of non-compatible chemicals, or damage to property, or loss of income due to malfunctions of the product.

If a difficulty develops with this machine, you should contact the dealer from whom it was purchased.

This warranty gives you specific legal rights, and you may have other rights which vary from state to state. Some states do not allow the exclusion or limitation of special, incidental or consequential damages, or limitations on how long an implied warranty lasts, so the above exclusions and limitations may not apply to you.

Minuteman[®]

World Headquarters
Minuteman International, Inc.
111 South Rohlwing Road
Addison, Illinois 60101

Minuteman Canada, Inc.
2210 Drew Road
Mississauga, Ontario
L5S 1B1

(630) 627-6900
FAX (630) 627-1130

(905) 673-3222
FAX (905) 673-5161

987705
Printed in U.S.A.