



Electronic Service Manuals

This electronic document is provided as a service to our customers. We do not create the contents of the information contained in this document. Should you have detailed questions pertaining to the information contained in this document, you may contact Michco, or the manufacturer which provided the original information in this electronic deliverable. Michco's only part in this electronic deliverable was the electronic assembly process. By providing this manual on line we are not guaranteeing parts availability.

You may contact Michco through the following methods:

Phone (517) 484-9312 or (800) 331-3339

2011 N. High St. -- Lansing, Michigan -- 48906

Fax: (517) 484-9836

Email: CustServe@Michco.com

Web site: www.Michco.Com

Parts Web site: www.FloorMachineParts.Com

Order Parts on Line at:

www.FloorMachineParts.Com

Directly to Parts & Service:

By Email: **Shop@Michco.com**

By Fax: (517) 702-2041

By Voice: Use numbers above.

Serving the Cleaning Industry Since 1922

Notice: All copyrighted material remains property of original owners, all trademarks are property of respective owners. Manuals are subject to Manufacturer's reproduction limitations. Originals or reproductions were provided by manufacturers through a request. We make no warranty as to the correctness of information provided in this document and you assume all risk. By placing these manuals on line we are not declaring our corporation to be an manufacturer authorized dealer or provider, please check our web site for authorized manufacturers we represent.

**390 Vacuum
Series
15, 30 & 55
Gallon Units**

**Model No: C39085-01,02,03,04
C39105-01,02,03,04
C39130-01,02,03,04
C39330-01,02,03,04,05,06
C39055-01,02,03,04,05,06**

**Stainless Steel
& Painted**

OPERATION

SERVICE

PARTS

CARE

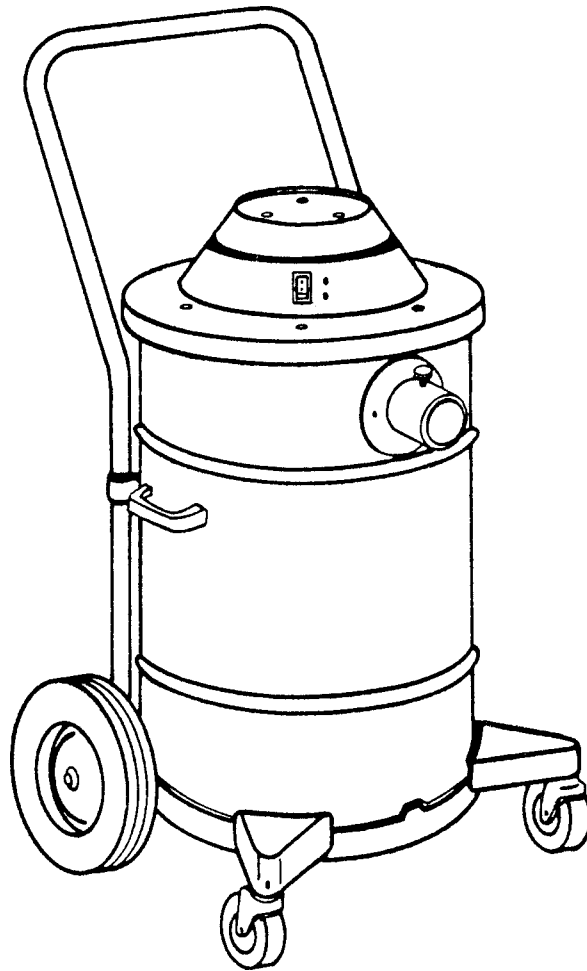

Revised 6/02

Minuteman[®]

FOR COMMERCIAL USE ONLY

IMPORTANT SAFETY INSTRUCTIONS

When using an electrical appliance, basic precautions should always be followed, including the following:

READ ALL INSTRUCTIONS BEFORE USING

WARNING - To reduce the risk of fire, electric shock, or injury:

- Do not leave appliance when plugged in. Unplug from outlet when not in use and before servicing.
- To avoid electrical shock, do not expose to rain, store indoors.

WARNING:

To reduce the risk of electrical shock - Do not use on wet surfaces. Do not expose to rain. Store indoors.

- Do not allow to be used as a toy. Close attention is necessary when used by or near children.
- Use only as described in this manual. Use only manufacturer's recommended attachments.
- Do not use with damaged cord or plug. If appliance is not working as it should, has been dropped, damaged, left outdoors, or dropped into water, return it to a service center.
- Do not pull or carry by cord, use cord as a handle, close a door on cord, or pull cord around sharp edges or corners. Do not run appliance over cord. Keep cord away from heated surfaces.
- Do not unplug by pulling on cord. To unplug, grasp the plug, not the cord.
- Do not handle plug or appliance with wet hands.
- Do not put any object into openings. Do not use with any opening blocked; keep free of dust, lint, hair, and anything that may reduce air flow.
- Keep hair, loose clothing, fingers, and all parts of body away from openings and moving parts.
- Do not pick up anything that is burning or smoking, such as cigarettes, matches, or hot ashes.
- Do not use without dustbag and/or filters in place.
- Turn off all controls before unplugging.
- Use extra care when cleaning on stairs.
- Do not use to pick up flammable or combustible liquids such as gasoline or use in areas where they may be present.
- Connect to a properly grounded outlet only. See grounding instructions.

SAVE THESE INSTRUCTIONS

INSPECTION

Carefully unpack and inspect your machine for shipping damage. Each unit is tested and thoroughly inspected before shipment, and any damage is the responsibility of the delivery carrier who should be notified immediately.

ELECTRICAL - 115 Volt

This machine is designed to operate on a standard 15 amp, 115 volt, 60 hz, AC circuit. Voltages below 105 volts AC or above 125 volts AC could cause serious damage to the motor.

ELECTRICAL - 240 Volt

This machine is designed to operate on a standard 10 amp, 230 volt, 50 hz, AC circuit.

GROUNDING INSTRUCTIONS

This appliance must be grounded. If it should malfunction or breakdown, grounding provides a path of least resistance for electric current to reduce the risk of electric shock. This appliance is equipped with a cord having an equipment-grounding conductor and grounding plug. The plug must be plugged into an appropriate outlet that is properly installed and grounded in accordance with all local codes and ordinances.

DANGER

Improper connection of the equipment-grounding conductor can result in a risk of electric shock. Check with a qualified electrician or service person if you are in doubt as to whether the outlet is properly grounded. Do not modify the plug provided with the appliance — if it will not fit the outlet, have a proper outlet installed by a qualified electrician.

This machine is for use on a nominal 120 volt circuit and has a grounding plug that looks like the plug illustrated in Sketch A. Make sure that the machine is connected to an outlet having the same configuration as the plug. No adapter should be used with this appliance.

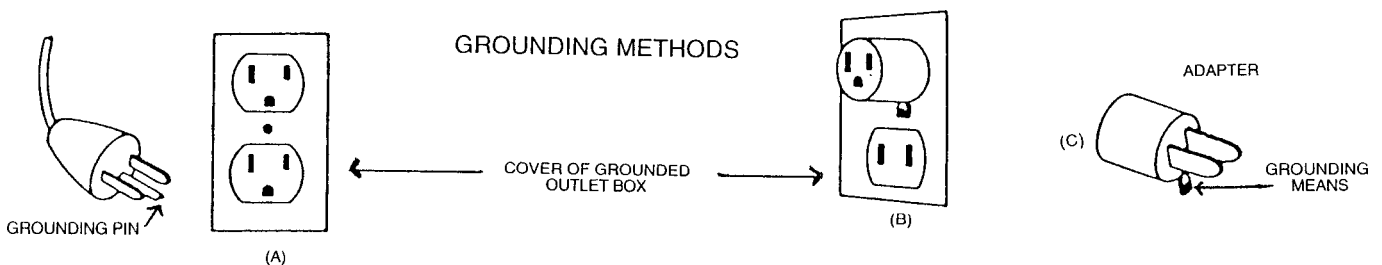

WARNING

This vacuum may contain potentially hazardous dust depending on its application. Special handling of contaminated disposal bags and filters is recommended. Disposal must be in compliance with local EPA regulations

USER MAINTENANCE INSTRUCTIONS

All service and repair should be performed by qualified vacuum service representative or electrician. No user serviceable components are employed in the electrical vacuum lid head assembly. No lubrication of the motor is required.

CLOTH BAG & HOSE ASSEMBLY

Cloth bag and hose assembly are user maintenance items and can be replaced when worn out. For optimum performance, empty and clean filter bag regularly. A clogged and dirty bag restricts the flow of air and results in reduced vacuum. The hose assembly can be maintained by wiping off with a dampened cloth of mild liquid soap and water, then allowed to dry.



CORD STORAGE

While not in use storage can be accomplished by winding cord around motor lid assembly. Cord should be completely unwound from lid assembly during operation.

- Do not use with damaged cord or plug. If appliance is not working as it should, has been dropped, damaged, left outdoors, or dropped into water, return to service center.
- Do not pull or carry by cord, use cord as handle, close a door on cord, or pull cord around sharp edges or corners. Do not run appliance over cord. Keep cord away from heated surfaces.
- Do not unplug by pulling cord. To unplug, grasp the plug, not the cord.
- Do not handle plug or appliance with wet hands.
- Always unplug the machine when removing the motor head off the tank.
This equipment should be stored indoors and not exposed to rain.

Always unplug the machine when removing the motor head off the tank. This equipment should be stored indoors and not exposed to rain.

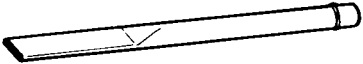
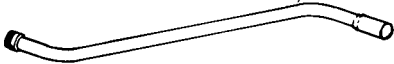
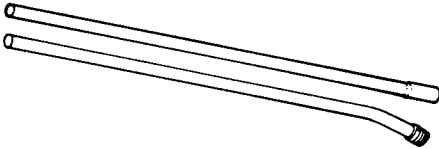
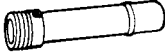
OPTIONAL INDUSTRIAL TOOLS AND ACCESSORIES

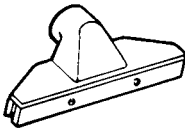
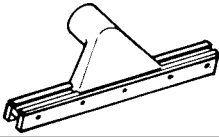
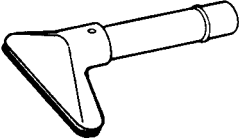
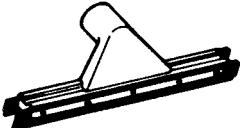
		Part No.	Description
A		800024 800022 800023 800175MCH 800176MCH 800025	3" Rd Dust Brush Complete 5" Rd Dust Brush Complete Bristle Insert 5" Dust Brush HSG 5" Dust Brush HSG 3" Bristle Insert 3"
B		800034	24" Crev Tool Aluminum Comp
C		800015	Wand Asy 1-1/2, Complete
D		800017 800064 800019	Set Tube, High-up 10' 5' Tube Lower Section 5' Section Upper
E		800116	Swivel, Hose End Exp, Comp
F		800303	Hose Asy 1-1/2 x 10'
G		800032 711006 800033 800193POL	6" Curved Pipe Tool, Comp Set Screw Bristle Insert Curved 6" 6" Curved Pipe Tool
H		800070 710356 710357 800187PTD 800217 800218	12" Gulper Tool, Comp SCR-MC 10-32 x .62 SCR-MC 10-32 x .75 Gulper Nozzle Fibre Shoe Rear Fibre Shoe Front
I		800108 710530 800003MCH 800178PTD	14" Fibre Tool Complete Screw 8/32 x 1/2 Brass Fibre Shod Tool Casting
J		800038 800029	6" Tool Squeegee, Complete Bristle Insert Replacement
K		800109 710330 800121 800178PTD 800239 800240	14" Squeegee, Comp SCR-SC 8-32 x .62 14" Retaining Strip Casting, Tool MCH Blade Squeegee Wide Blade Squeegee Narrow

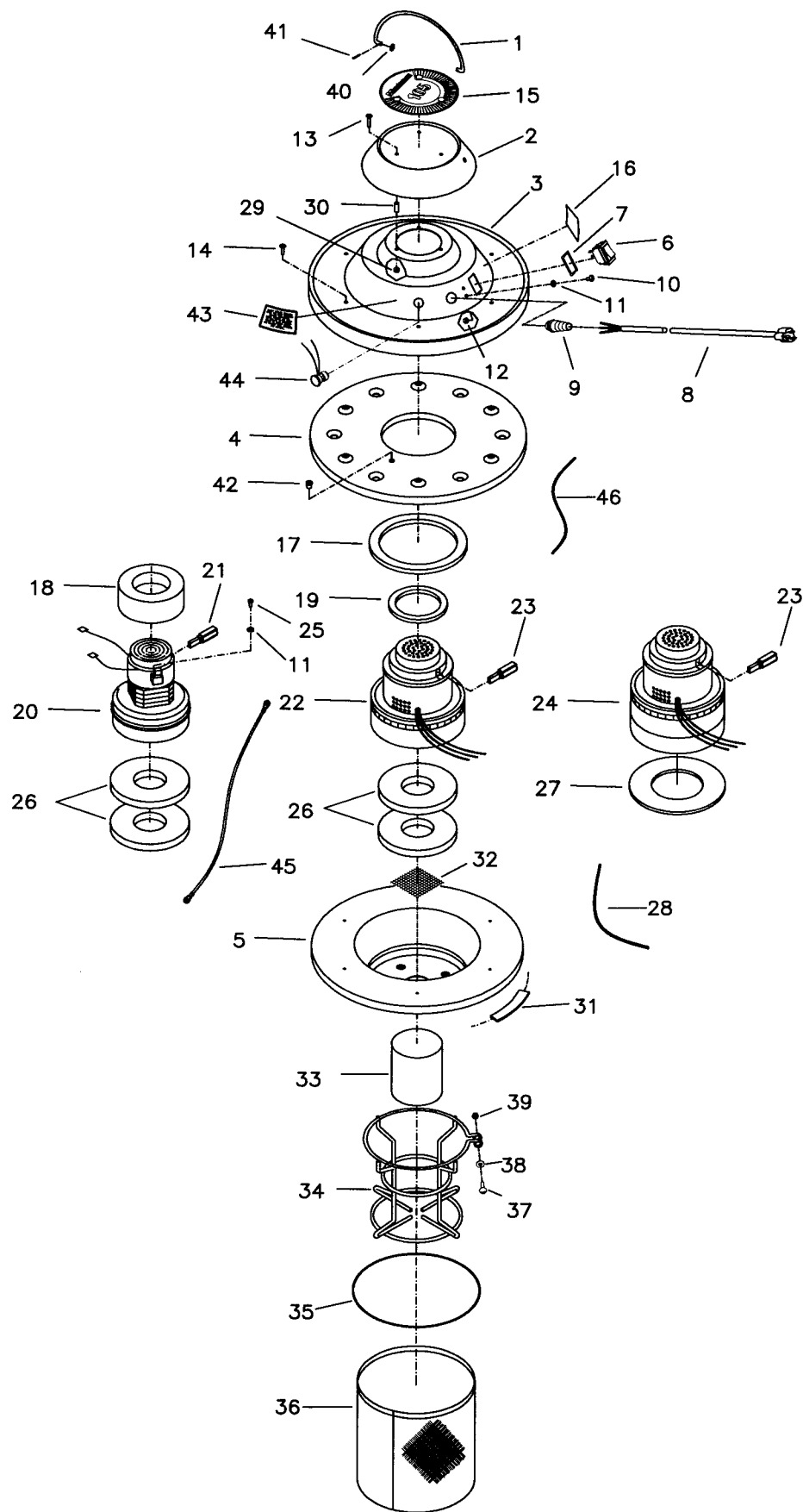

Parts List

Item	Part No	Qty	Description
1	760899	1	Handle Bail
2	760898PLT	1	Cap, Motor
3	760897PLT	1	Cover, Motor
4	760896	1	Shroud, Motor
5	760985PH	1	Pan, Motor
6	809754	1	Switch, Rocker
7	450088	1	Spacer, Switch
8	381020	1	Gray Cord Ste 16-3 50'
8A	740600	1	Cord HO5 VV-F3G1.5 x 50'
9	833237	1	Strain Relief
10	710355	2	SCR-MC 10-32 x .50 STPL
11	711553	2	WSR-Internal Lock #10
12	711310	2	Nut-Hex 10-32 x .50 STPL
13	712823	3	SCR-THMS 10-24 x 1.00 STPL
14	711126	6	SCR-ST-B 10 x .75 STPL
15	715105	1	Decal, P/V 105
15A	715085	1	Decal, P/V 85
15B	715130	1	Decal, P/V 130
16	715086	1	Decal, Warning
17	831478	1	Gasket, Neop 6 x 7.5 x .37
18	380064	1	Foam Ring
19	831484	1	Gasket, 3.5 x 4.5 x .31
20	380001	1	Vac Motor, Bypass 115V-85
20A	380054	1	Vac Motor, Bypass 240V-85
21	380028	2	Brush, Carbon-85
22	255039	1	Vac Motor, Bypass 115V-105
22A	255040	1	Vac Motor, Bypass 240V-105
23	255008	2	Brush, Carbon-105
24	831524	1	Vac Motor, Stage 3 115V-130
24A	831526	1	Vac Motor, Stage 3 240V-130
25	711124	1	SCR-ST-B 10 x .37
26	828995	2	Gasket, Neop 2.5 x 6 x .62
27	831626	1	Gasket 4 x 7.37 x .250
28	760213	1	Venturi Tube
29	712908	3	Nut-Flanged Wizz 10-24
30	831652	3	Spacer
31	290030	1	Lid Gasket
32	807051	1	Screen Filter SS 85/105
32A	832317	1	Screen Filter SS 130
33	830987	1	Float
34	833454	1	Float Cage
35	760260	1	Spring, Bag Retainer
36	760901	1	Lint Filter
37	712569	1	SCR-MC1/4-20 x 1.50 SS
38	711506	1	WSR-Flat 5/16 ST PL
39	712667	1	Nut-Hex 1/4-20 SS Nyloc
40	711505	2	WSR-Flat 1/4
41	711803	1	Cotter Pin
42	760904	1	Snub Bushing
43	715069	1	Decal, Check Filters
44	740088	1	Vac Light
45	740116	1	Ground Wire
46	760212	1	Vac Sensor Tube

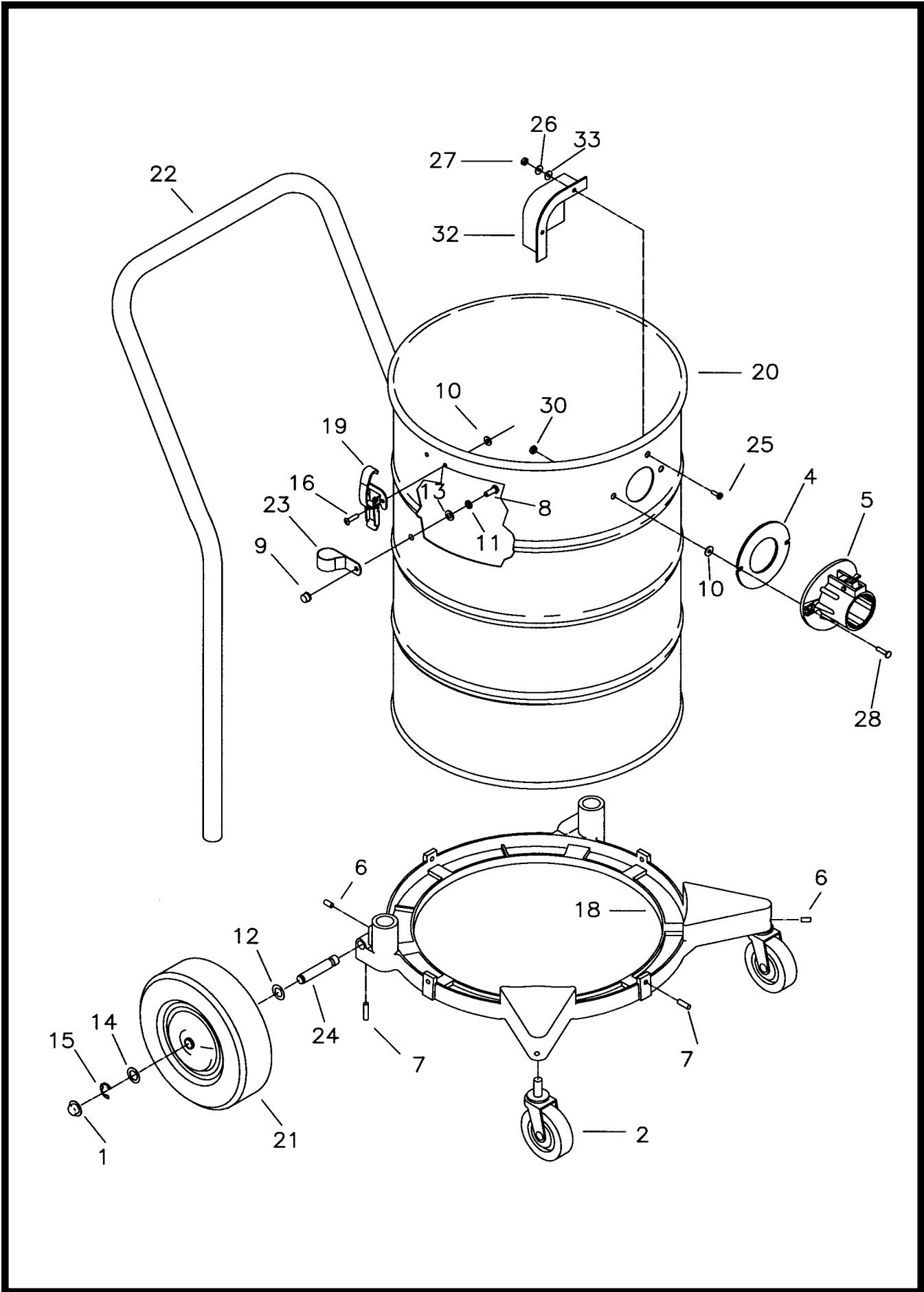

Parts List

Item	Part No	Qty	Description
1	130032	2	Cap, Retainer
2	280016	2	Caster 3"
3	900112	1	Intake, MCH (750381-2 Only)
4	390087	1	Gasket Diecut
5	390110	1	Intake Assy Aluminum
6	711005	4	SCR-SK 1/4-20 x .31
7	711006	6	SCR-SK 1/4-20 x .62
8	711202	2	BLT-HH 1/4-20 x .50 STPL
9	711352	2	Nut-Acorn 1/4-20 ST NI
10	711503	8	WSR-Flat #10
11	711505	2	WSR-Flat 1/4
12	711524	2	WSR-Wave .52 x .87 x .01
13	711591	4	WSR-Rubber
14	711594	2	WSR-Flat .56 x .88 x .03 NI
15	711713	2	Retaining Ring Ext .50
16	711915	6	Rivet-Tube .19 x .28 NI PL
18	760984PTD	1	Bracket, Wheel
19	761054	2	Latch
20	900001PTD	1	Tank 15G Painted
20A	900003POL	1	Tank 15G Polished
21	900008	2	Wheel 8.00 DIA
22	900037PLT	1	Handle, Plated
23	900038	2	Clamp, Handle
24	900066	2	Axle
25	710530	1	SCR-MC 8-32 x .50 BR
26	711502	1	WSR-Flat #8
27	711372	1	Nut-Nloc 8-32 (750382 Only)
27A	711304	1	Nut-Hex 8-32 (750381-2 Only)
28	712824	2	SCR-THMS 10-24 x .75 STPL
29	500033	1	Locking Screw (750381-2 Only)
30	712638	2	Nut Hex 10/24 SS Nyloc
32	900035	1	Deflector, Intake
33	711542	1	Helical Washer #8
***	390012	1	Molded Intake Complete
***	390015	1	Molded Adapter 1 1/2
***	390020	1	Molded Adapter 2.00
***	750220	1	Tank Assy Comp 15gal PTD Asbestos
***	750221	1	Tank Assy Comp 15gal SS Asbestos
***	750322	1	Wheel Brkt Asy Comp
***	750381	1	Tank Asy Comp PTD W/Deflector
***	750382	1	Tank Asy Comp SS W/Deflector

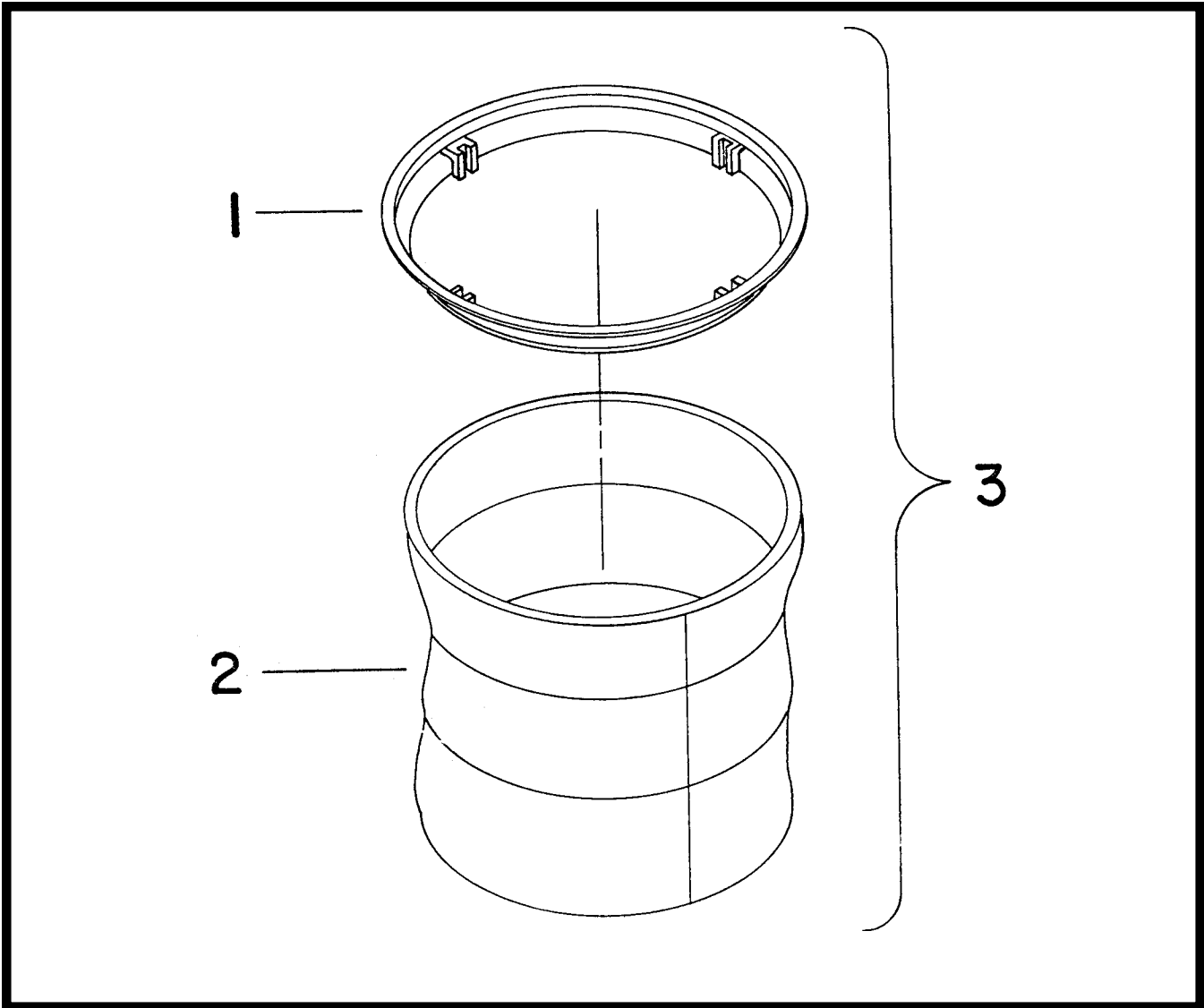

Parts List

Item	Part No	Qty	Description
1	760131	1	Molded Bag Ring
2	805054	1	Cloth Bag Only
3	805058	X	Cloth Bag Asy Comp

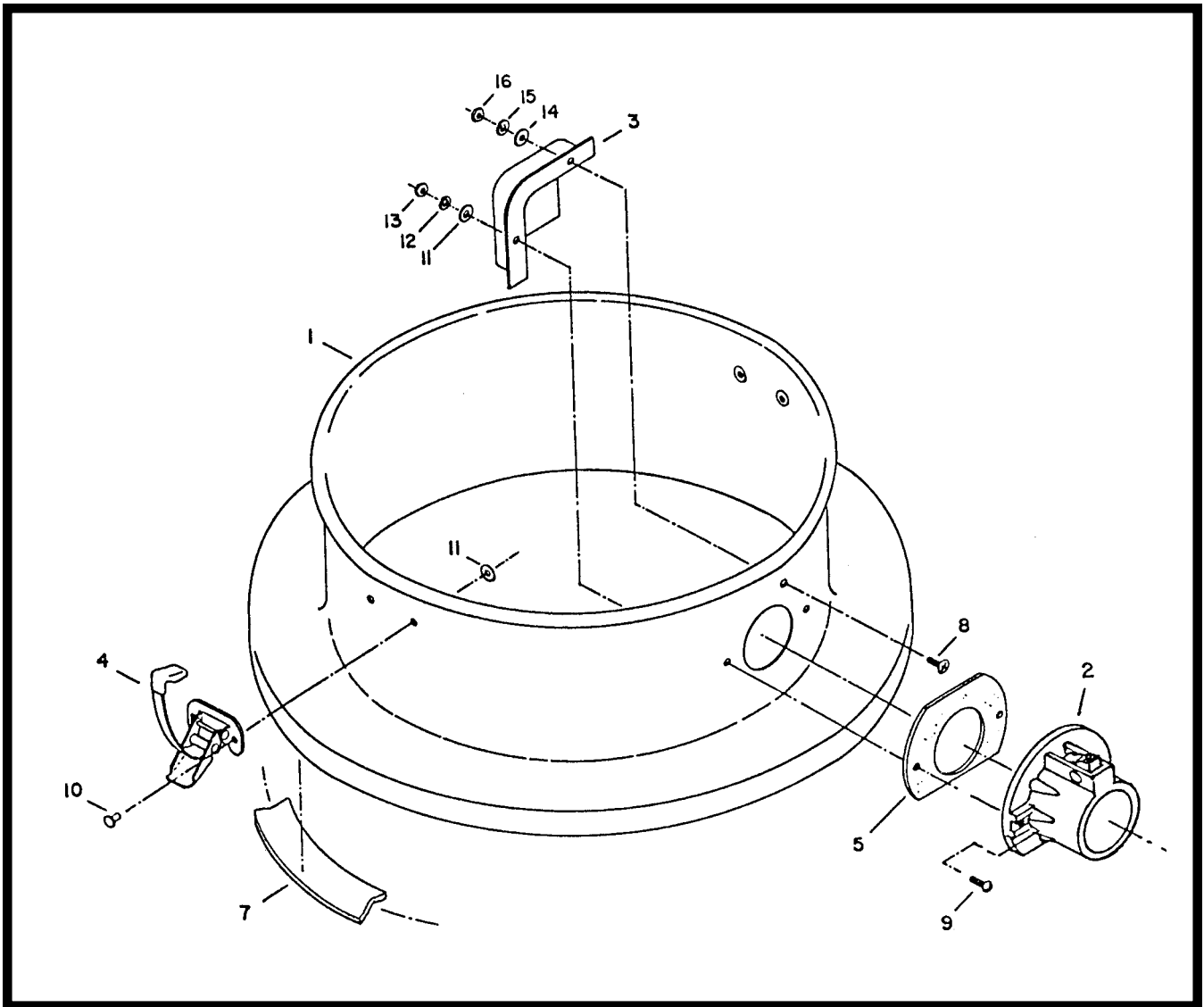

Parts List

Item	Part No	Qty	Description
1	806016PTD	1	55 Gal Adapter, Painted
2	806015PTD	1	30 Gal Adapter, Painted
3	390100MCH	1	Molded Intake MCH 15/30
4	900035	1	Deflector, Intake
5	761054	2	Latch
6	390087	1	Gasket Diecut Pron Intake
7	806006	1	Gasket, Raw
8	710530	1	SCR-MC 8-32 x .50 BR
9	712824	2	SCR-THMS 10-24 x .75 STPL
10	711915	4	Rivet-Tube .19 x .28 NI PL
11	711503	6	WSR-Flat #10
12	711543	2	WSR-Helical #10
13	712638	2	Nut-Hex 10/24 SS Nyloc
14	711502	1	WSR-Flat #8
15	711542	1	WSR-Helical #8
16	711304	1	Nut-Hex 8-32 STPL
***	C80601-70		30 Gal Adapter Assy
***	C80601-80		55 Gal Adapter Assy

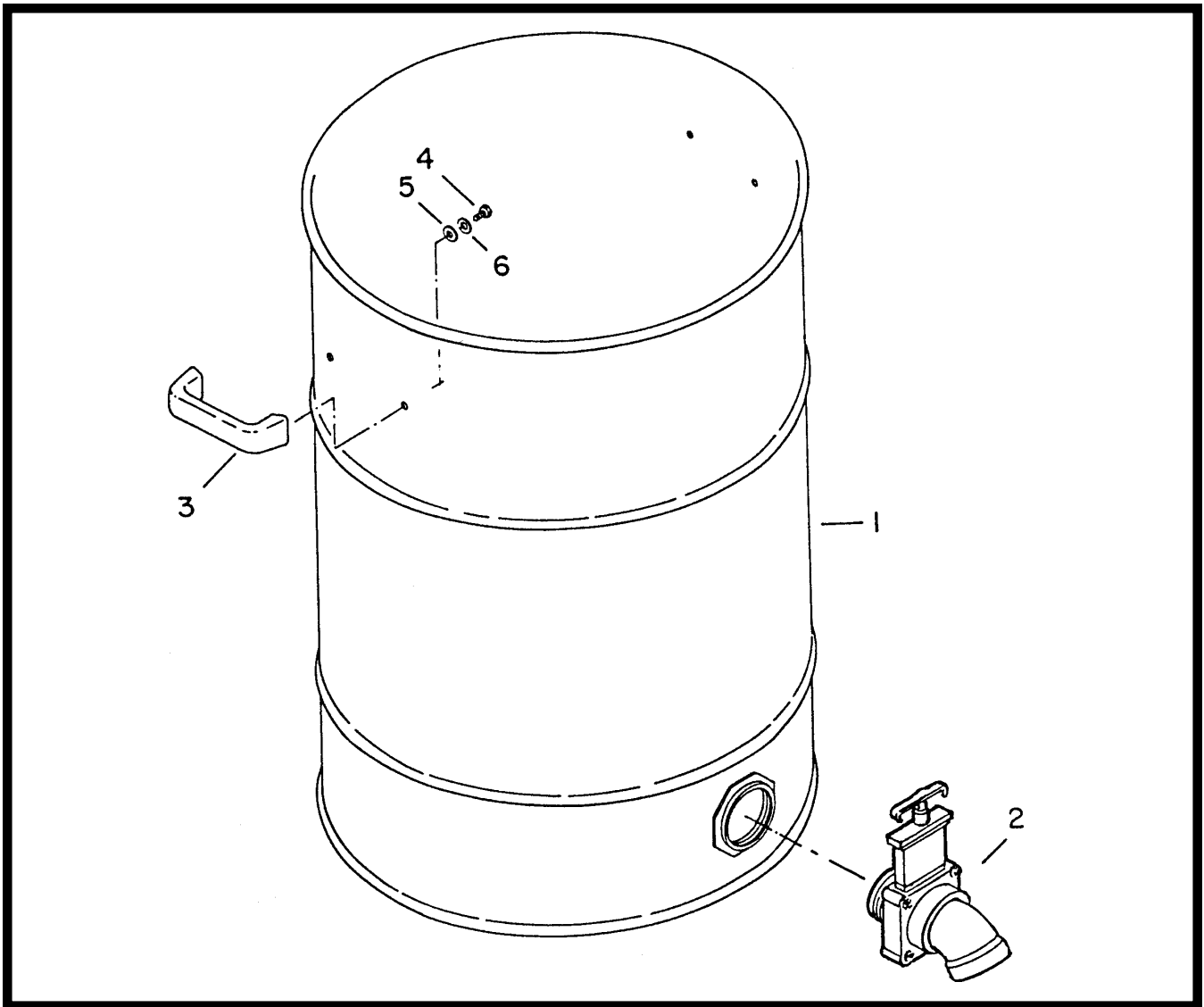

Parts List

Item	Part No	Qty	Description
1	900078PTD	1	Tank 30 Gal PTD Less Handles
1A	900015PTD	1	Tank 55 Gal PTD No Handles
2	900047	1	Dump Valve
3	900031POL	2	Handle, Tank Polished
4	711203	4	BLT, HH 1/4-20 x .62
5	711591	4	Washer, Rubber
6	711505	4	WSR, FLat 1/4
***	C90007-80		Tank 30 Gal Pkg 12
***	805037PKG		Drum Liner 30 Gal Pkg 12
***	805046PKG		Drum Liner 55 Gal Pkg 12

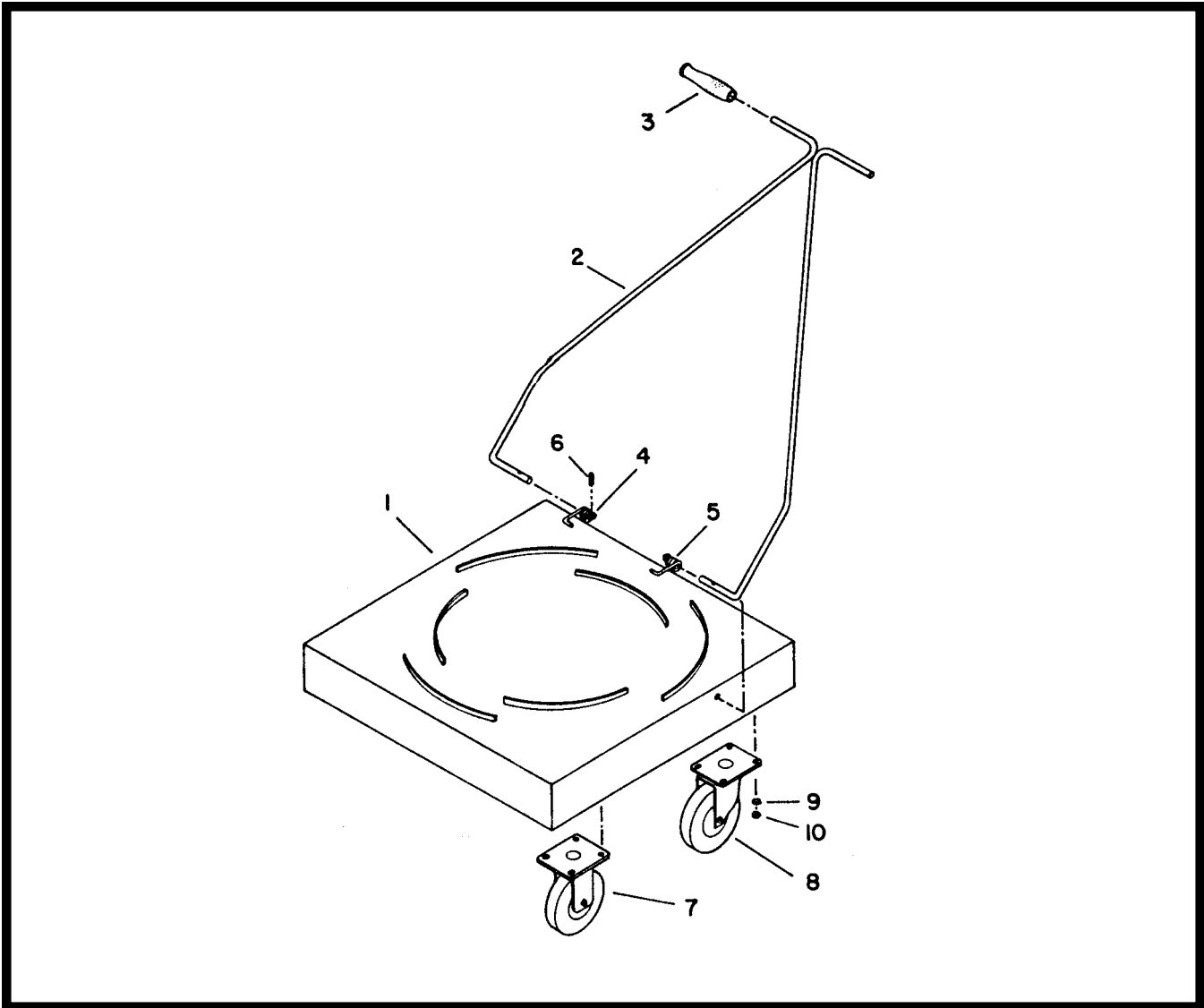

Parts List

Item	Part No	Qty	Description
1	750045	1	Weldment Dolly 30/55
2	900051	1	Weldment Handle
3	900052	2	Grip, Handle
4	900080	1	Spring, Torsion RH
5	900081	1	Spring LH
6	711642	2	Rollpin
7	761050	2	Caster, Rigid 5"
8	761049	2	Caster, Swivel 5"
9	711545	16	WSR-Helical Spr Loc 5/16
10	711319	16	Nut-Hex 5/16-18 ST PL
***	900048		Dolly Cart, Complete

LIMITED WARRANTY

Minuteman International, Inc. warrants to the original purchaser/user that this product is free from defects in workmanship and materials under normal use and service for a period of three years from date of purchase. In addition, Minuteman International, Inc. will, at its option, honor labor warranty claims for the first 12 months from date of sale, provided such claims are submitted through and approved by factory authorized repair stations. Minuteman International, Inc. will, at its option, repair or replace without charge, except for transportation costs, parts that fail under normal use and service when operated and maintained in accordance with the applicable operation and instruction manuals.

This warranty does not apply to normal wear, or to items whose life is dependent on their use and care, such as belts, cords, switches, hoses, rubber parts, electrical motor components or adjustments. Parts not manufactured by Minuteman International, Inc. such as engines, batteries, battery chargers, hydraulic pumps, and tires are covered by and subject to the warranties and/or guarantees of their manufacturers. Please contact Minuteman International, Inc. for procedures in warranty claims against these manufacturers.

Special warning to purchaser — Use of replacement filters and/or prefilters not manufactured by Minuteman International, Inc. or its designated licensees, will void all warranties expressed or implied.

A potential health hazard exists without exact original equipment replacement.

All warranted items become the sole property of Minuteman International, Inc. or its original manufacturer, whichever the case may be.

Minuteman International, Inc. disclaims any implied warranty, including the warranty of merchantability and the warranty of fitness for a particular purpose. Minuteman International, Inc. assumes no responsibility for any special, incidental or consequential damages.

This limited warranty is applicable only in the U.S.A. and Canada, and is extended only to the original user/purchaser of this product. Customers outside the U.S.A. and Canada should contact their local distributor for export warranty policies. Minuteman International, Inc. is not responsible for costs or repairs performed by persons other than those specifically authorized by Minuteman International, Inc. This warranty does not apply to damage from transportation, alterations by unauthorized persons, misuse or abuse of the equipment, use of non-compatible chemicals, or damage to property, or loss of income due to malfunctions of the product.

If a difficulty develops with this machine, you should contact the dealer from whom it was purchased.

This warranty gives you specific legal rights, and you may have other rights which vary from state to state. Some states do not allow the exclusion or limitation of special, incidental or consequential damages, or limitations on how long an implied warranty lasts, so the above exclusions and limitations may not apply to you.

Minuteman[®]

World Headquarters
Minuteman International, Inc.
111 South Rohlwing Road
Addison, Illinois 60101

Minuteman Canada, Inc.
2210 Drew Road
Mississauga, Ontario
L5S 1B1

(630) 627-6900
FAX (630) 627-1130

(905) 673-3222
FAX (905) 673-5161

987312
Printed in U.S.A.