

M □ □ □ □ □ □

This electronic document is provided as a service to our customers. We do not create the contents of the information contained in this document. Should you have detailed questions pertaining to the information contained in this document, you may contact Michco, or the manufacturer which provided the original information in this electronic deliverable. Michco's only part in this electronic deliverable was the electronic assembly process. By providing this manual on line we are not guaranteeing parts availability.

You may contact Michco through the following methods:

Phone (517) 484-9312 or (800) 331-3339

2011 N. High St. -- Lansing, Michigan -- 48906

Fax: (517) 484-9836

Email: CustServe@Michco.com

Web site: www.Michco.Com

Parts Web site: www.FloorMachineParts.Com

Order Parts on Line at:



Directly to Parts & Service:

By Email: □ □ □ □ □ **M** □ □ □ □ □ □ □ □ □ □

By Fax: (517) 702-2041

By Voice: Use numbers above.

Serving the Cleaning Industry Since 1922

Notice: All copyrighted material remains property of original owners, all trademarks are property of respective owners. Manuals are subject to Manufacturer's reproduction limitations. Originals or reproductions were provided by manufacturers through a request. We make no warranty as to the correctness of information provided in this document and you assume all risk. By placing these manuals on line we are not declaring our corporation to be an manufacturer authorized dealer or provider, please check our web site for authorized manufacturers we represent.

Kleen Sweep 35 Sweeper

Model:
HM360000
HM350000

OPERATION

SERVICE

PARTS

CARE

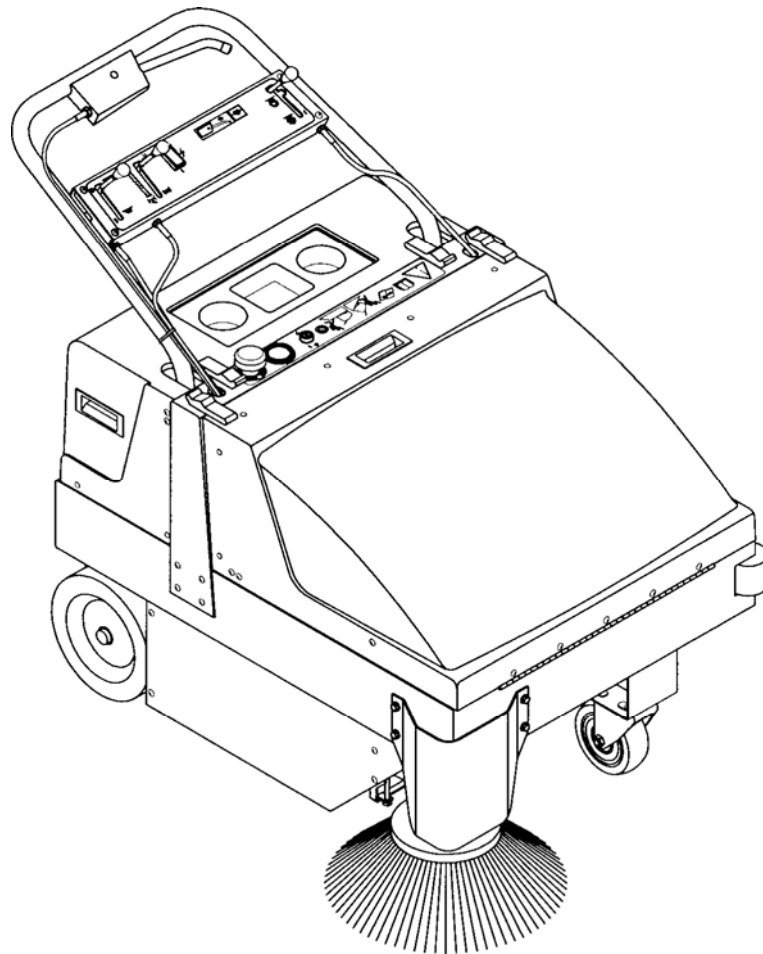

Revised 2/02

Minuteman[®]

TABLE OF CONTENTS

	Page
Safety Instructions	1
Electrical Requirements	2
Control Panel Identification	3 - 5
Operating Instructions	6
Maintenance of Machine	7
Main Components	8 - 21
Wiring Diagram	22 - 23

EC Declaration of Conformity

according to Directives 89/392 and 89/336

We, Minuteman International Incorporated, of 111 South Rohlwing Road Addison Illinois 60101 USA, declare under our sole responsibility that the product HM360000 & PB360000 Commercial Floor Sweeping machines to which this declaration relates corresponds to the relevant requirements of the EC Directives 89/392 and 89/336. The following standards were used to determine compliance with the Directives: EN 292, EN 294, EN 811, EN 55011, EN 55104 and EN 50082-2.

SOUND		VIBRATION
70 dB Operator	66 dB At 3m	1.2 m/s² At Operators Handle
Tests were conducted on 8/6/96 with calibrated sound and vibration equipment under the conditions noted below:		
General Condition: Sunny	Wind: 0 km/hr	
Temperature: 28 ⁰ C	Humidity: 85%	
Barometric Pressure: 30.1		

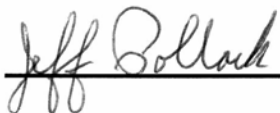

Jeff Pollack, Standards Engineer

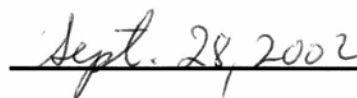

Date

IMPORTANT SAFETY INSTRUCTIONS

CAUTION

Operators must read and understand this manual before operating or maintaining this equipment.

- Keep hands and feet clear of moving parts while machine is in operation.
- All switches must be in the “OFF” position when charging batteries.
- Electrical motors and components can cause an explosion when operated near explosive materials or vapors. Do not operate this machine near flammable materials such as solvents, thinners, fuels, grain dusts, etc.
- Make sure all switches are turned “OFF” and battery connections are removed before performing any maintenance procedures.
- Store or park this machine on a level surface only.
- These machines are designed for level floor operation only. DO NOT OPERATE on ramps or inclines.
- Battery acid can cause burns. When working on or around batteries, wear protective clothing and safety glasses. Remove metal jewelry. Do not lay tools or metal objects on top of batteries.

Charging batteries generates explosive gases. DO NOT CHARGE BATTERIES WHEN OPEN FLAMES OR SPARKS ARE PRESENT. DO NOT SMOKE. Make sure the charger is turned off before disconnecting it from the batteries. Charge the batteries in a well-ventilated area.

Maintenance and repairs must be performed by authorized personnel.

SAVE THESE INSTRUCTIONS

ELECTRICAL REQUIREMENTS:

This piece of equipment operates on 12 Volts DC.

BATTERY REQUIREMENTS:

1 x 12V 185AH P/N 956709

BATTERY SERVICE AND INSTALLATION:

* Warning: Battery acid can cause burns. When working on or around batteries, wear protective clothing and safety glasses. Remove metal jewelry. Do not lay tools or metal objects on top of batteries.

BATTERY INSTALLATION:

1. Install battery as shown in figure 1 below.

CHARGING OF BATTERIES:

Charging of batteries generates explosive gases. DO NOT CHARGE BATTERIES WHEN OPEN FLAMES OR SPARKS ARE PRESENT. DO NOT SMOKE. Make sure the charger is turned off before disconnecting it from the batteries. Charge the batteries in a well-ventilated area. Fluid levels should be checked before and after charging and maintained at the proper levels.

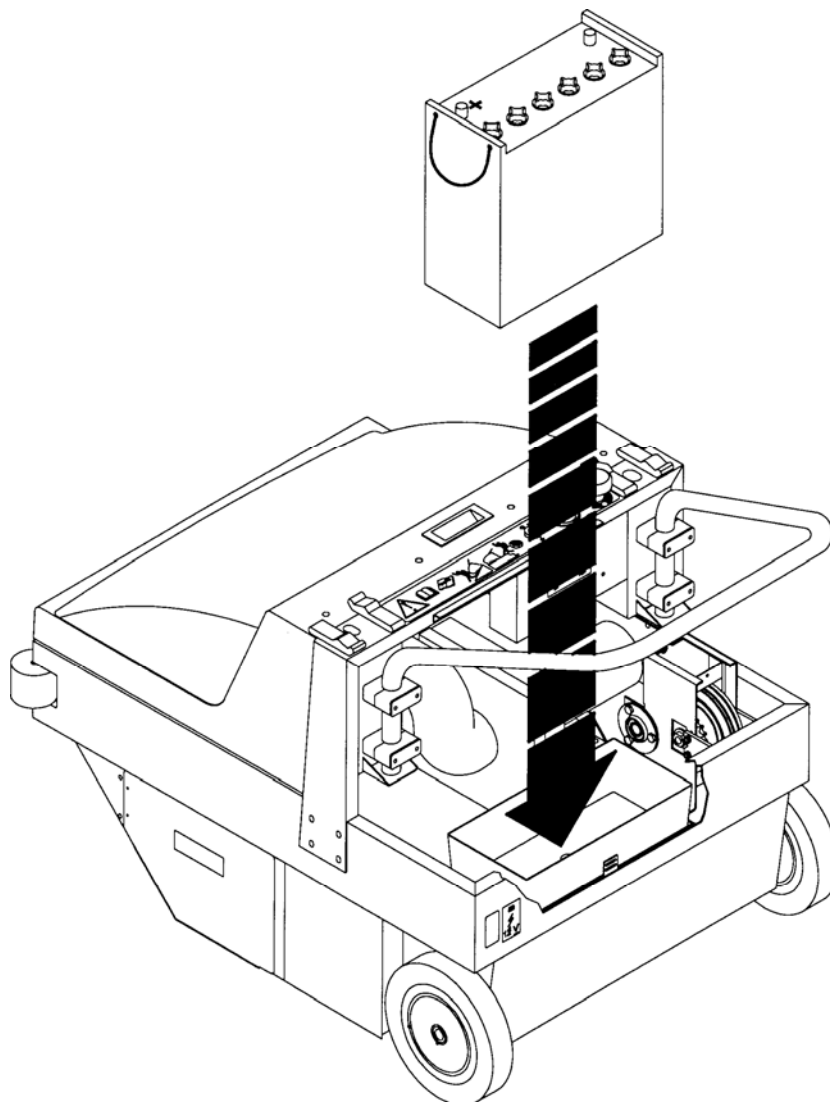

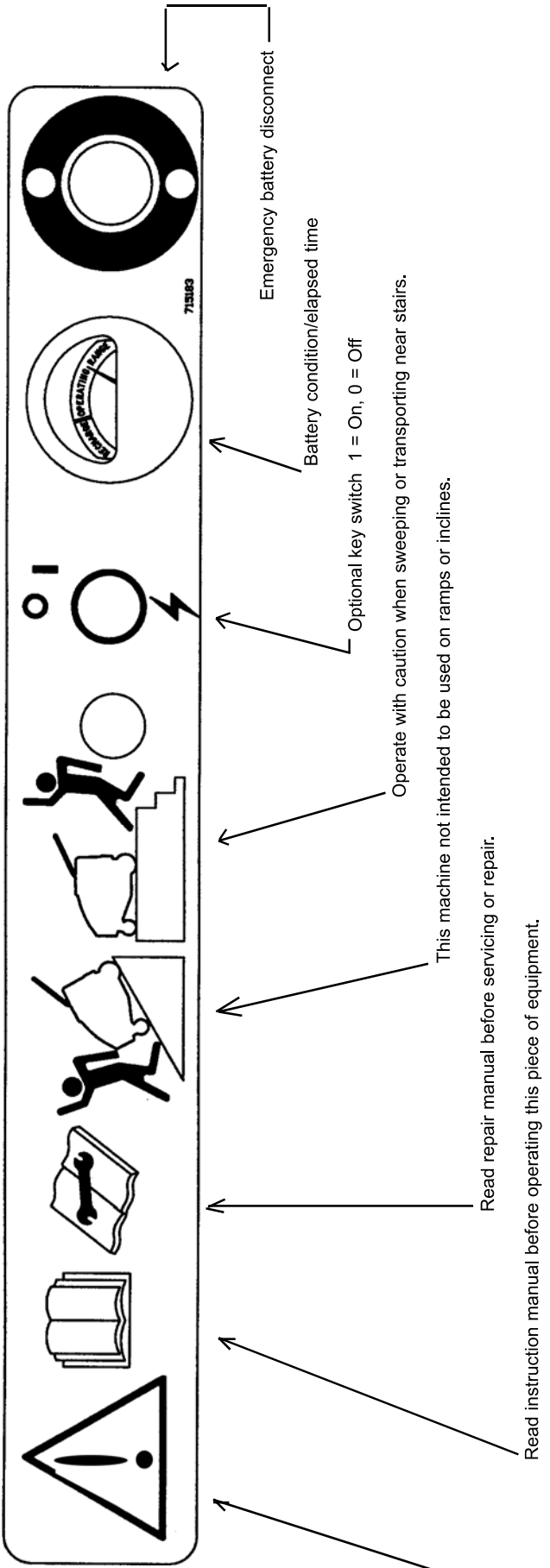

⚠ This symbol signifies warnings about operator safety.

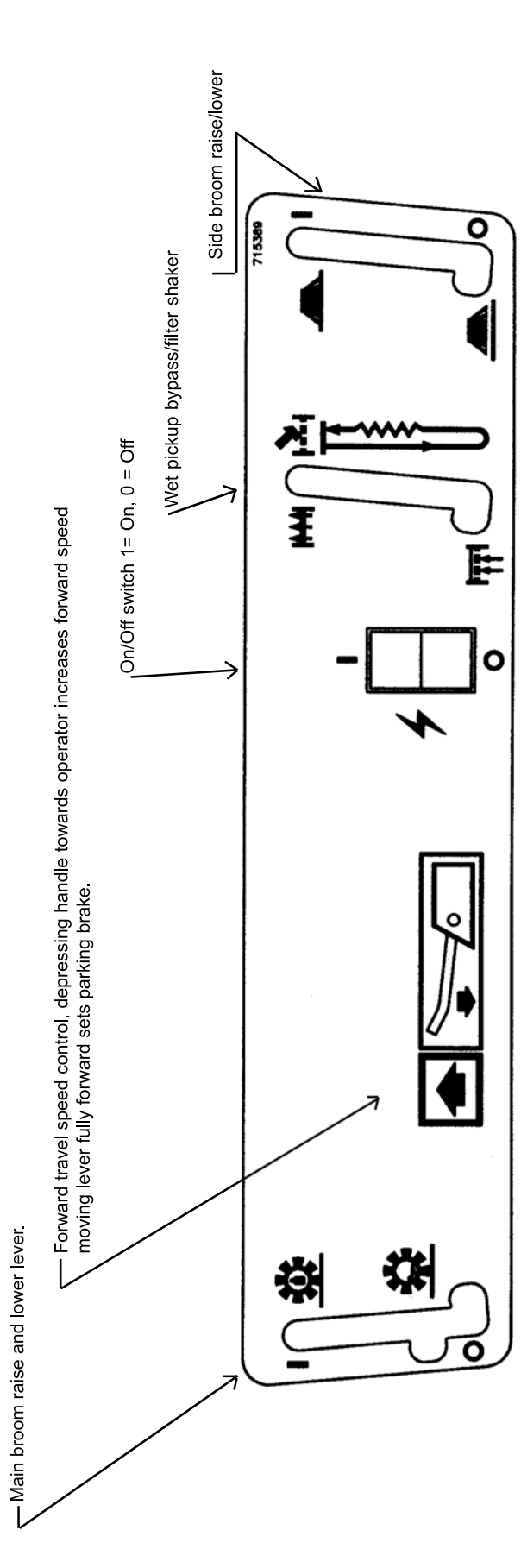

OPERATING CONTROLS

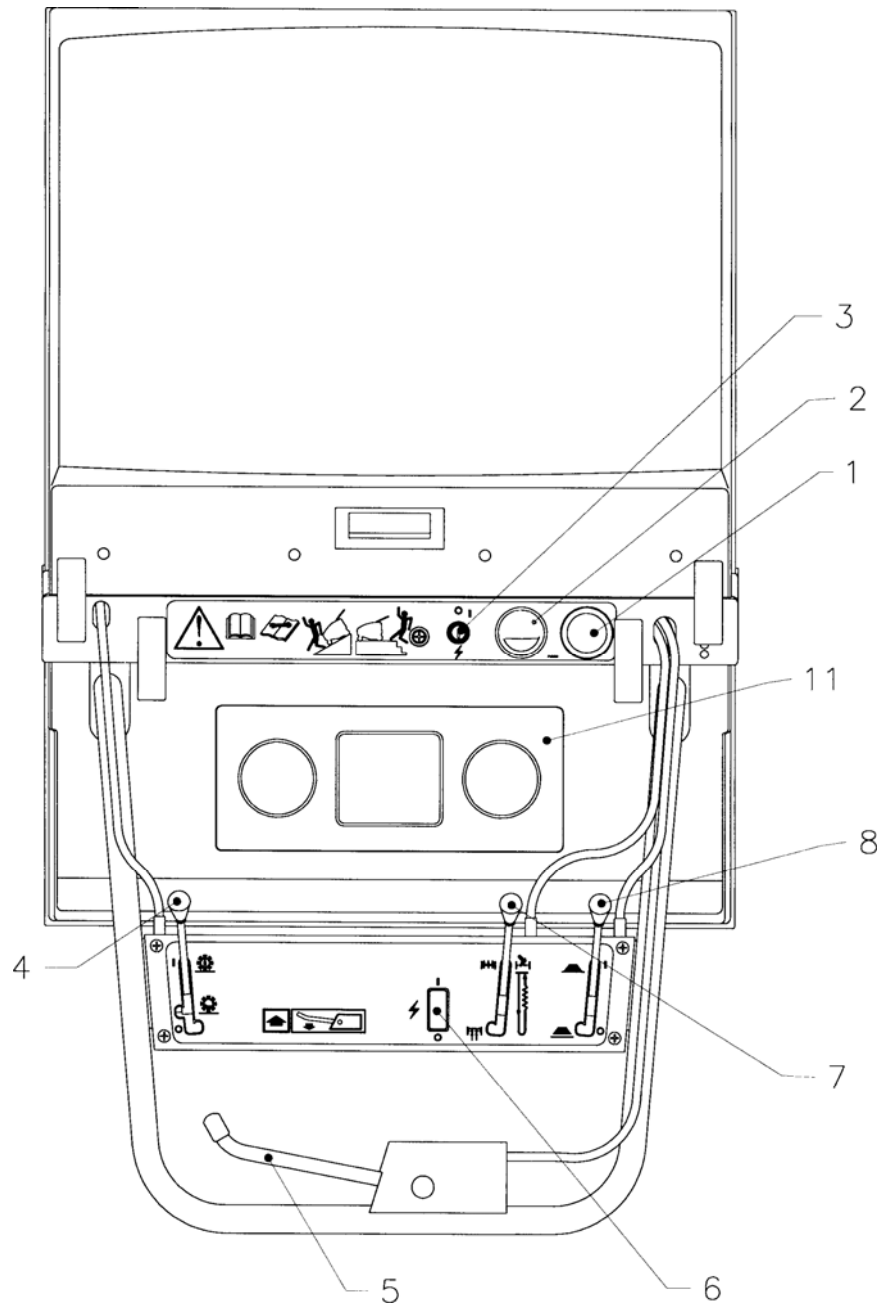

1. Emergency Stop Switch
2. Battery Condition Gauge
3. Key Switch (optional)
4. Main Broom Lift Control
5. Forward Speed Control/Parking Brake Lever
6. Power Switch

CIRCUIT BREAKER LOCATION

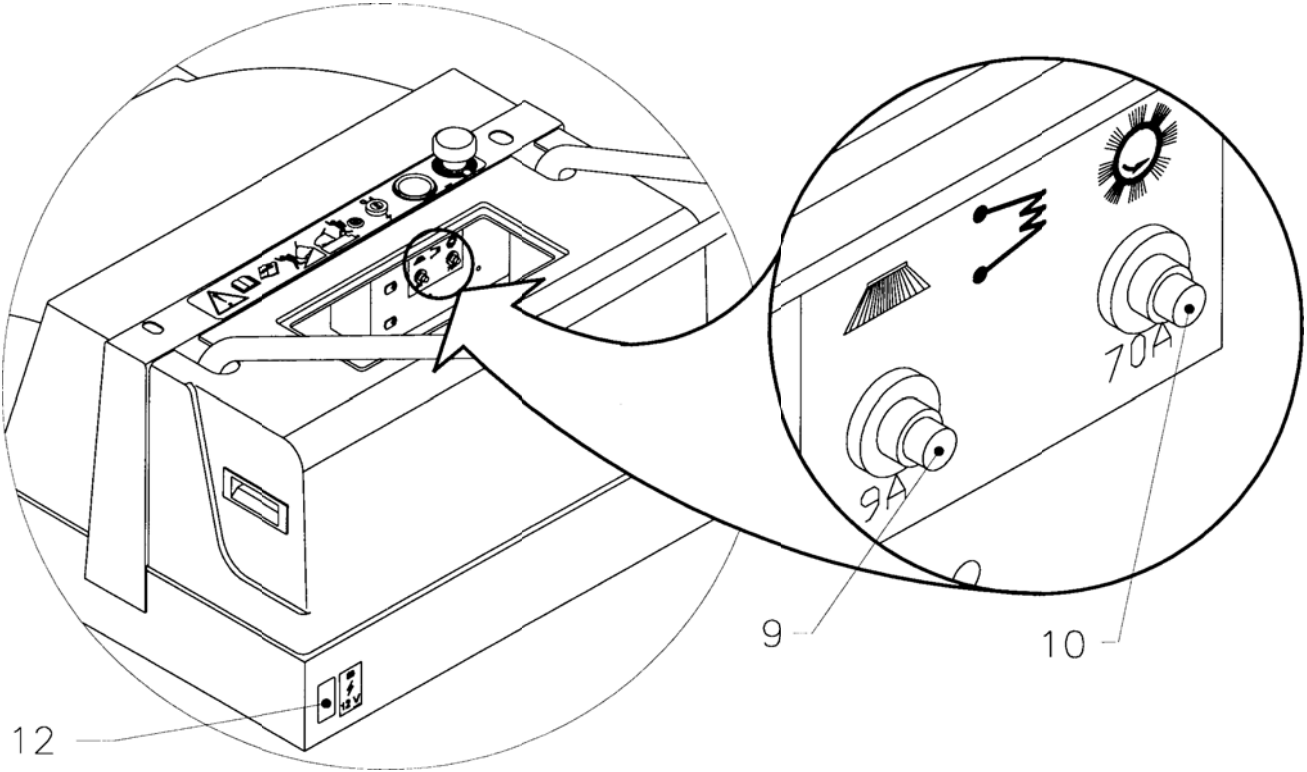

- 7. Vacuum Interrupt/Filter Cleaning Control
- 8. Side Broom Lift Control
- 9. Side Broom Motor Circuit Breaker
- 10. Main Broom Motor Circuit Breaker
- 11. Cup Holder/Battery Inspection Access Panel
- 12. Battery Charging Connector

OPERATION

This equipment contains front and rear cover safety interlocks. This equipment will not operate if covers are not closed and latched in place.

The side broom when lowered ref. lever 8 page 4 will automatically turn on. The side broom sweeps along curbs and edges, moving dirt and debris into the sweeping path of the main broom.

The main broom is lowered by lever #4 page 4 for sweeping. The engagement of the lever in the second upmost raised position is for sweeping low cut closed loop type commercial carpet. Fully raised position is for transport.

Vacuumed dust control lever ref. lever 7 page 4, when sweeping wet areas or wet garbage also during transport of the machine from place to place. This lever should be in the raised position. To shake dust from the panel filter this lever should be raised and released several times to shake dust from the filter into the hopper. During normal operation the lever should be in the lowered position.

MAIN BROOM ADJUSTMENT

The height of the broom can be adjusted by loosening nut (1) removing cotter pin (2) and removing clevis pin (3). Clockwise rotation of yoke (4) will decrease brush contact, counterclockwise will increase.

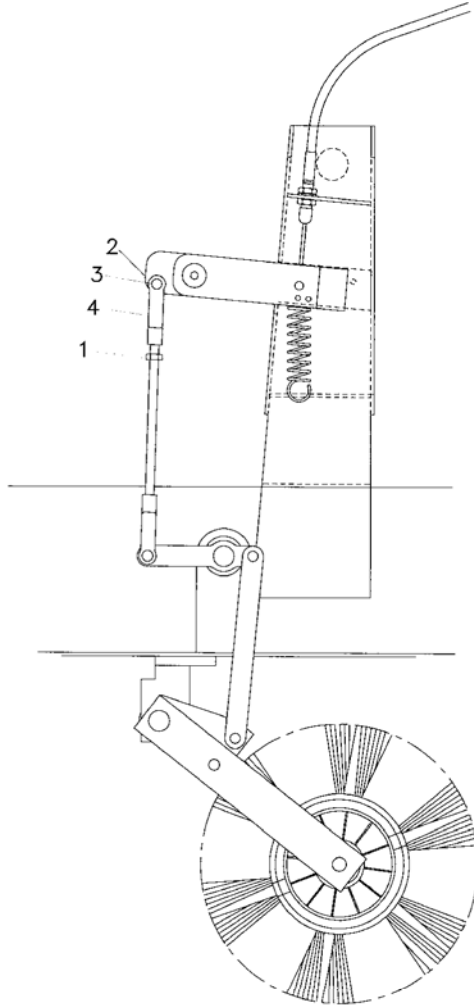

HOPPER

To empty hopper. Slide hopper out from side of machine as shown.

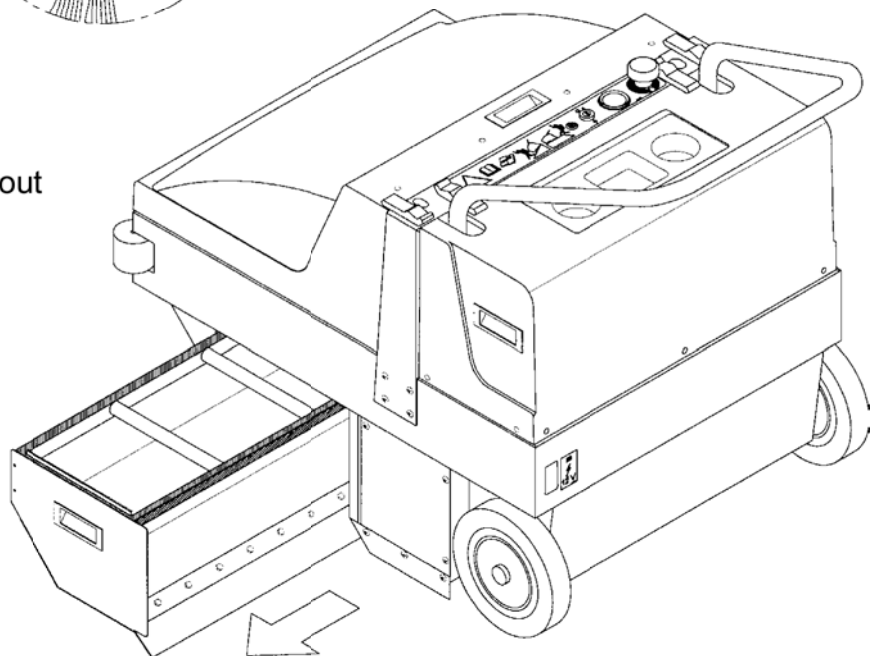

Parts List

Item	Part No.	Qty.	Description
1	361228	1	Rear Tray
2	827666	8	Rivet
3	711114	8	8-32 x .5 A Point Screw
4	450207	4	Latch
5	833436	1	Tilt Cable ACS
6	712536	5	SCR-MCH 10-24 x .62 SS
7	711373	4	Nut, Hex 1/4-20 Nyloc
8	710587	2	1/4-20 x 1.5 Flat Head Screw
9	712319	2	.31 x .78 Finish Washer
10	711505	4	Flat Washer 1/4
11	715183	1	Decal, Instruction
12	712638	5	Nut, Hex 10-24 Nyloc SS
13	711501	8	Washer, #6
14	361286	2	Cable Clip 1/8
15	250040	1	Spring, Extension SS .25 x 8

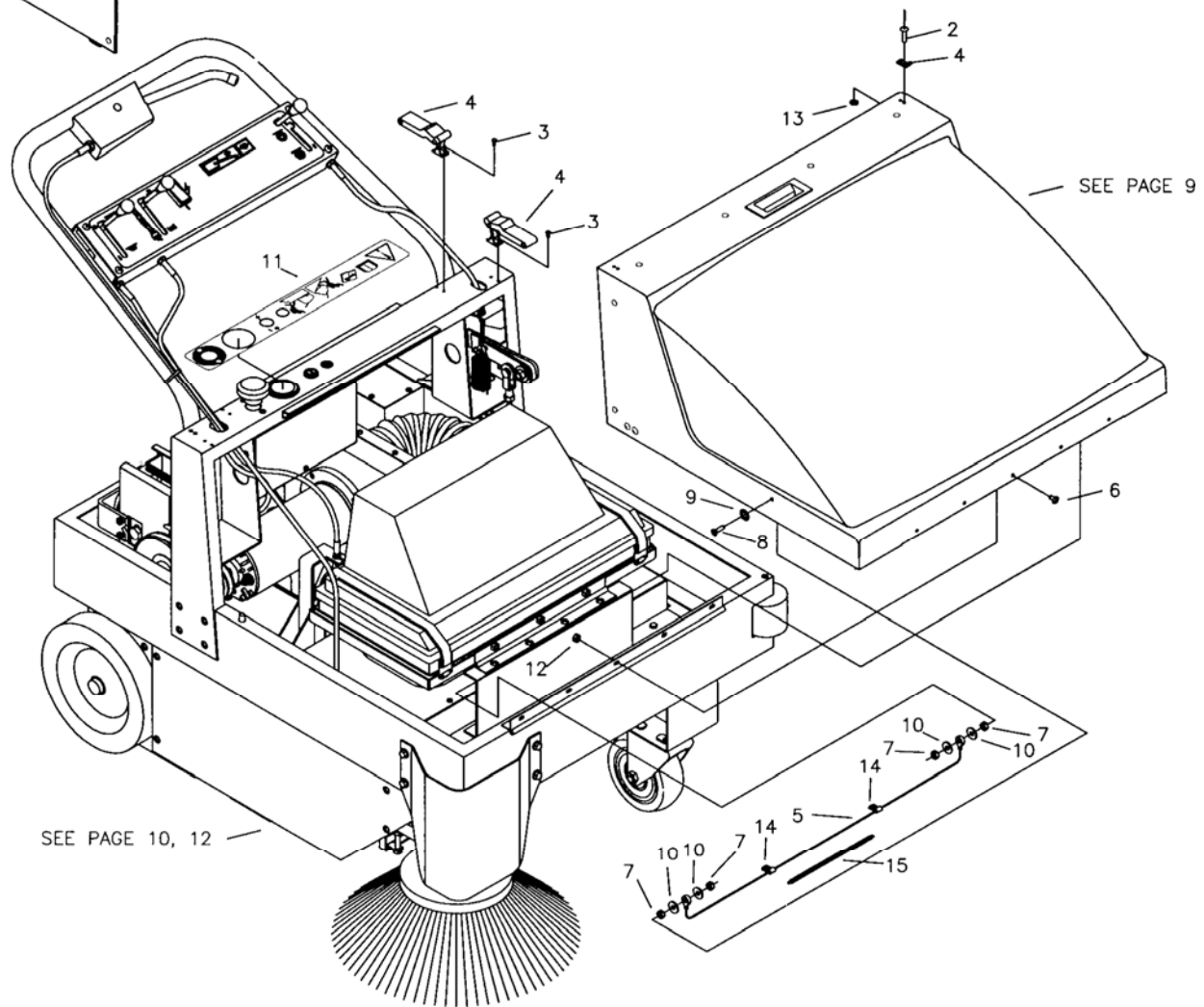
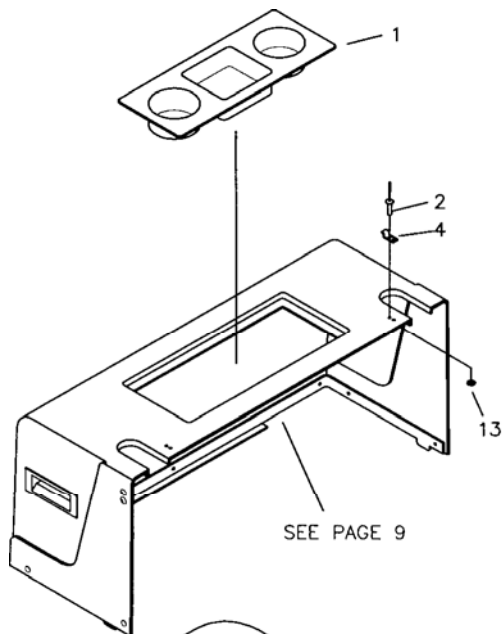

Parts List

Item	Part No.	Qty.	Description
1	361000	1	Front Cover
2	361267	1	Stiffener, Front
3	828893	8	Pop Rivet
4	361263	1	Pocket Pull
5	361227	1	Switch Bracket
6	710180	2	SCR-MCH 1/4-20 x .75
7	711373	2	Nut-Hex 1/4-20 Nyloc

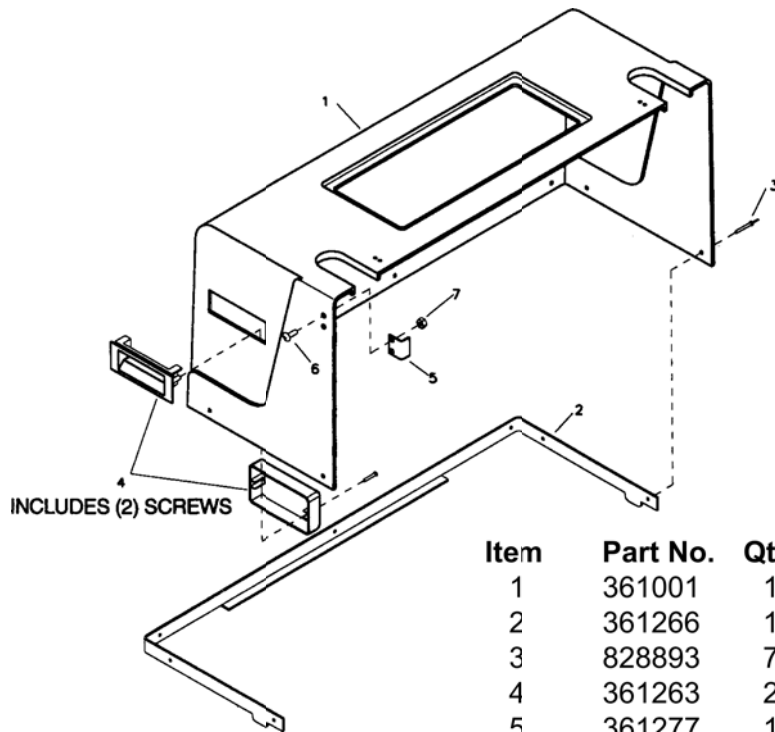
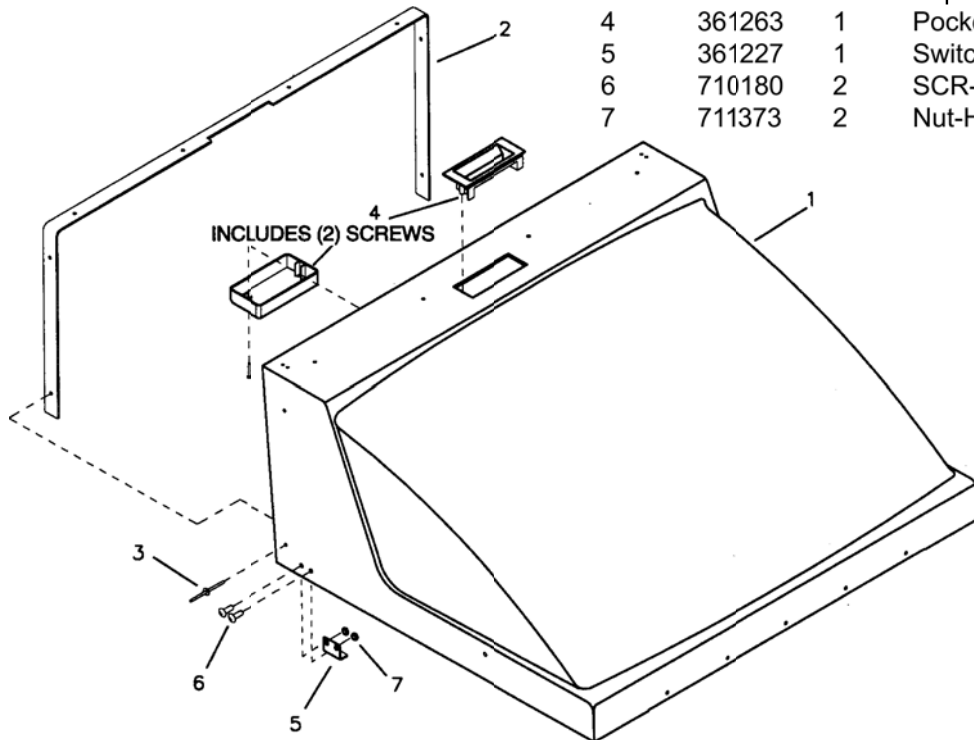

Parts List

Item	Part No.	Qty.	Description
1	361001	1	Rear Cover
2	361266	1	Stiffener, Rear
3	828893	7	Pop Rivet
4	361263	2	Pocket Pull
5	361277	1	Switch Bracket
6	710180	2	SCR-MC 1/4-20 x .75 STPL
7	711373	2	Nut-Nyloc 1/4-20

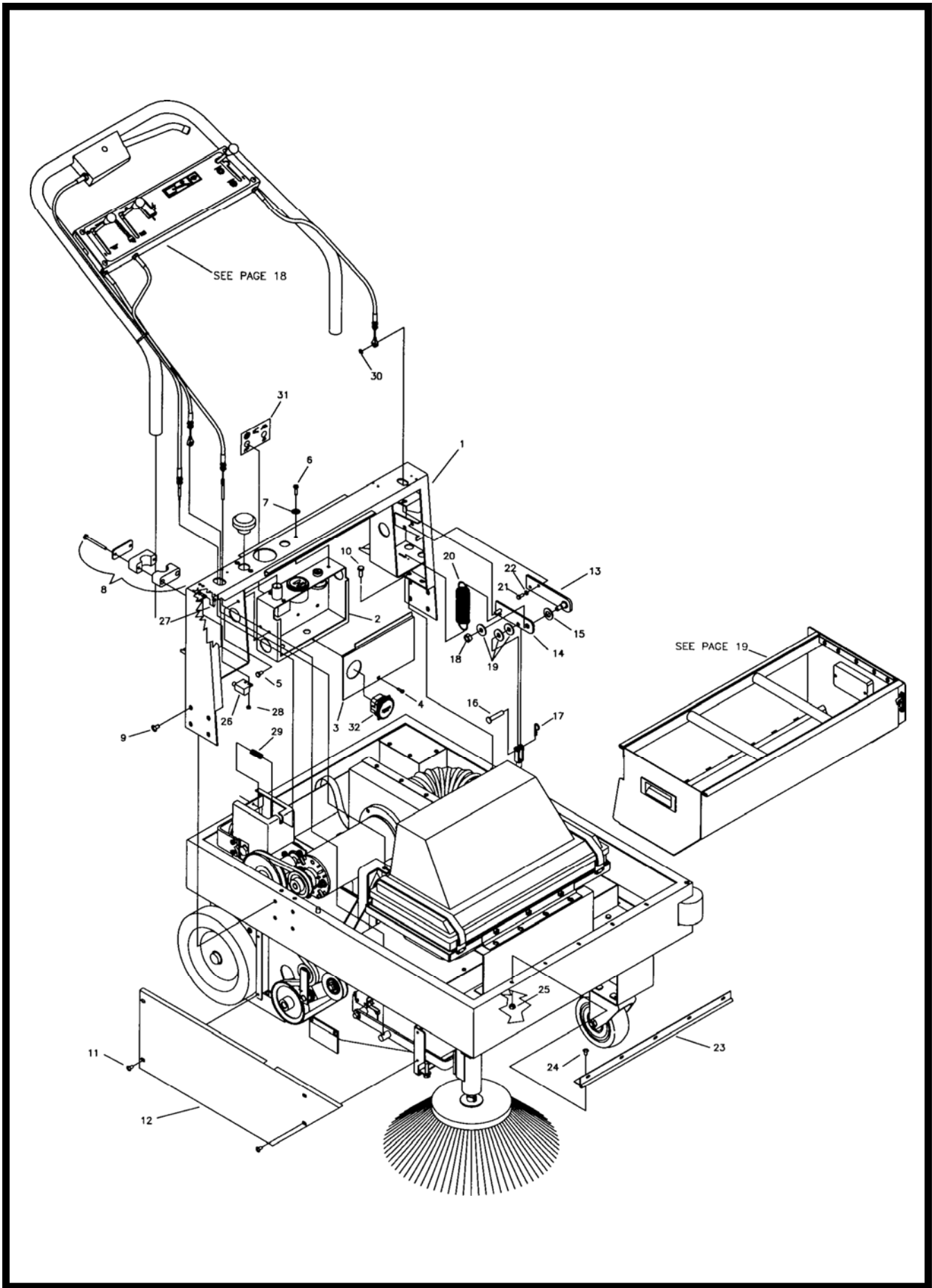

Parts List

Item	Part No.	Qty.	Description
1	361088	1	Handle Support Weldment
2	361140	1	Electrical Box Assembly
3	361132	1	Electrical Box Cover
4	711124	1	Screw 10 x .37 "B" Point
5	711202	2	1/4-20 x .50 H.H. Bolt
6	710601	1	1/4-20 x .75 Flat Head
7	712319	1	Dress Washer
8	361210	4	Handle Holder w/Mtg. Plate
9	710196	8	5/16-18 x .62 Truss Head
10	712042	4	5/16-18 x .62 Wizz Bolt
11	710180	4	1/4-20 x .75 Truss Head
12	361046	1	Right Side Dust Cover
13	361105	1	Pivot Bar Weldment
14	361183	1	Crank Arm
15	711592	1	Washer, Nylon
16	711668	1	Clevis Pin
17	833374	1	Pin Hair
18	711380	1	3/8-16 Hex Nyloc Nut
19	711507	3	WSR-Flat .37 x 1.12 x .06
20	760594	1	Extension Spring
21	711228	2	5/16-18 x .75 H.H. Bolt
22	711558	2	5/16 Internal Lock Washer
23	809171	1	Hinge Cover
24	712536	5	10-24 x .62 S.S. Screw
25	712638	5	10-24 SS Nyloc Hex Nut
26	740491	1	Switch
27	710329	2	8-32 x .5 Screw
28	711372	2	8-32 Nyloc Hex Nut
29	361161	1	Compression Spring
30	711717	1	Retaining Ring "E" .37
31	715184	1	Decal, Fuse
32	740539	1	Hour Meter 10-80 VDC

Parts List

Item	Part No.	Qty.	Description
1	742205	1	Drive Motor 12V
2	361008	1	Fan Cage
3	361032	1	Vacuum Fan Housing
4	361033	1	Fan Housing Lid Weldment
5	361233	2	Key, 3/16 Sq. x 1.5
6	711104	9	SCR-ST-A 10 x .50
7	711241	4	Bolt H.H. 3/8-16 x .75
8	711555	4	Washer Internal Lock 3/8
9	361276	1	Tubing, Flexible
10	361273	1	Pulley, Drive 4L 2.8 x .625
11	361142	1	Traction Drive Assembly
12	361272	1	Chain #40 32.5" Lg.
13	361038	1	Rear Cover
14	361007	1	Belt, 3L250
15	361006	1	Belt, 3VX475
16			
17			
18			
19			
20	827666	4	Pop Rivet
21	361036	1	Hole Reinforcement
22	361009	1	Vacuum Filter Lid
23	361014	2	Gasket
24	361013	2	Long Gasket
25	361012	1	Panel Filter
26	361010	1	Vacuum Filter Base
27	361187	1	Filter Base Gasket
28	361024	1	Filter Bracket Weldment
29	450021	1	Hinge
30	711373	5	Nut-Hex 1/4-20 Nyloc
31	710180	5	SCR-MCH 1/4-20 x .75
32			
33	760263	1	Foam Tape 5"
34	260180	1	U-Channel 5"
35	711228	4	BLT-HH 5/16-18 x .75 Lg.
36	711545	4	5/16 WSR-Helical
37	710329	2	8-32 x .5 Screw
38	740491	1	Switch, Cover Open
39	711372	2	Nut, 8-32 Nyloc
40	361243	2	Buckle, Filter Strap
41	361242	2	Filter Strap
42	72-416-10	4	1/4-20 x 5/8 HH Bolt
43	711544	4	Washer, Helical 1/4
44	740735		1 set Carbon Brushes (4 per set)

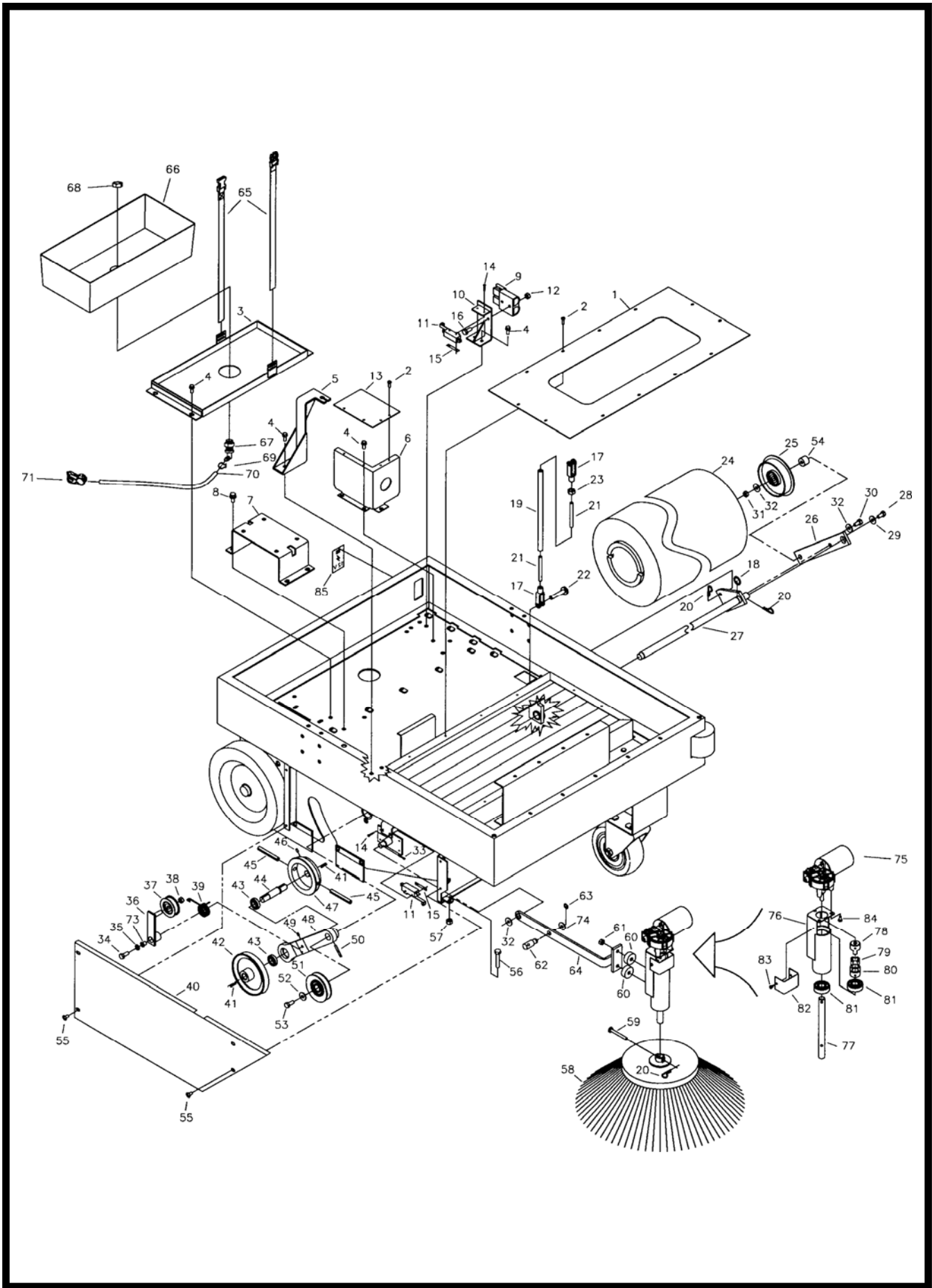

Parts List

Item	Part No.	Qty.	Description	Item	Part No.	Qty.	Description
1	361011	1	Filter Base Cover	44	361251	1	Main Brush Drive Shaft
2	711104	16	#10 Self Tapping Screw	45	711905	2	Rollpin 3/8 x 1.25
3	361041	1	Battery Tray Weldment	46	711004	2	1/4-20 x .25 Setscrew
4	72-416-10	13	1/4-20 x 5/8 HH T.C.	47	361212MCH	1	Brush Drive Hub
5	361115	1	CBL Hdlg. Brkt. Weldment	48	361209MCH	1	Brush Arm
6	361153	1	Charger Plug Housing	49	711014	1	10-24 x .25 Setscrew
7	361068	1	Motor Mount Bracket	50	711904	1	Rollpin .25 x 1.5
8	712042	4	5/16-18 x 5/8 Wizz Hd. Hex Bolt	51	361224	1	Brush Arm Pulley
9	742204	1	Charge Connector, Yellow	52	712301	1	Flat Washer .37 x .87 x .06
10	361135	1	Charge Plug Bracket	53	711241	1	3/8-16 x .75 HH Bolt
11	740128	2	Switch	54	62-132-A	1	Spacer
12	711373	2	1/4-20 Nyloc Nut	55	712560	4	1/4-20 x 1/2 Truss Hd. Screw
13	361257	1	Charger Plug Housing Lid	56	711247	1	3/8-16 x 2 HH Bolt
14	710307	4	6-32 x .87 Screw	57	711391	1	3/8-16 Nut
15	711430	2	Tinnerman Plate	58	361207	1	Side Broom
16	711210	2	1/4-20 x 1.25 HH Bolt	59	361221	1	Clevis Pin .25 x 1.5
17	361186	2	Yoke	60	831279	2	Grommet
18	711715	1	Retaining Ring	61	711374	2	5/16-18 Nyloc Nut
19	361280	1	Linkage Rod	62	762256PLT	1	Nut Adjust
20	809311	4	Cotter Pin - Hair	63	711717	1	Retaining Ring
21	361281	2	Threaded Rod	64	361080	1	Side Broom Arm
22	711668	1	3/8 x 1 Clevis Pin	65	361271	1	Strap Set
23	711420	1	5/16-18 Hex Jam Nut	66	361264	1	Battery Tray
24	361206	1	Main Broom	67	320271	1	90 Nozzle Body
25	361235	1	Pulley, Single Flange	68	320272	1	Nylon Lock Nut
26	361236	1	Arm, Brush Wheel	69	450076	1	Crimp Clamp SS 185R
27	361059	1	Major Axle Weldment	70	260224	1	Hose, Clear 18"
28	711241	1	3/8-16 x 3/4 HH Bolt	71	320273	1	Hose Shut-Off Clamp
29	711508	1	Flat Washer .44 x 1.00 x .08	72			
30	712074	1	1/2-13 x 2 HH Bolt	73	361201	1	Bushing
31	711376	1	1/2-13 Nyloc Nut	74	712310	1	Washer, Flat .52 x .87 x .06
32	711509	4	Flat Washer 1/2	75	742268	1	Side Broom Motor, 12V
33	711808	1	Cotter Pin	76	361249	1	Bearing Housing Weldment
34	711210	1	1/4-20 x 1.25 HH Bolt	77	361230	1	Shaft, Side Broom
35	711577	1	Flat Washer .26 x .5 x .06	78	361285	1	Hub, 3/8 Bore
36	361200	1	Idler Arm Weldment	79	361238	1	Spider Sox
37	361223	1	Idler Pulley	80	361237	1	Hub, 5/8 Bore
38	711375	1	3/8-16 Nyloc Nut	81	361231	2	Bearing, 5/8 Bore
39	361229	1	Idler Tension Spring	82	361241	1	Cover, Side Broom
40	361046	1	Right Side Dust Cover	83	711104	2	SCR-MC 10 x .5
41	361252	2	3/16 Sq. x .5 Key	84	361255	3	M6 x 1 HH Bolt
42	361188	1	Pulley, Brush Drive	85	715182	1	Decal, 12V
43	361254	2	Bearing .669 ID				

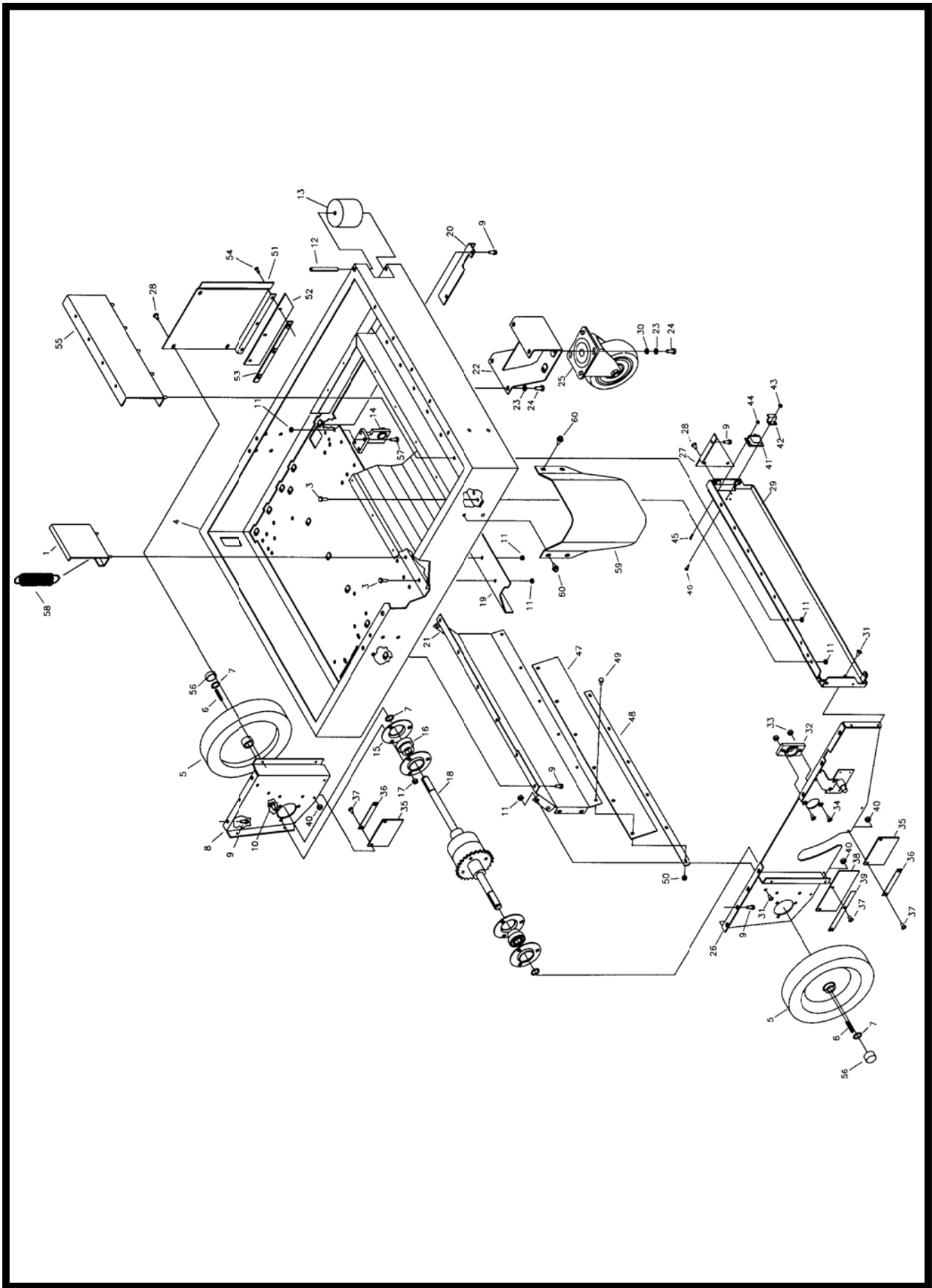

Parts List

Item	Part No.	Qty.	Description	Item	Part No.	Qty.	Description
1	361030	1	Filter Rest Bracket	31	710180	12	1/4-20 x .75 Truss Head Screw
2				32	361214	1	Nylon Bushing
3	711204	20	1/4-20 x 3/4 HH Bolt	33	711373	2	1/4-20 Nyloc Nut
4	361002	1	Mainframe Weldment	34	710584	2	1/4-20 x1 Flat Head Screw
5	361005	2	Wheel, 10 x 1.75	35	361202	2	4" Rubber Flap
6	361233	2	3/16 x 3/16 x 1.5 Key	36	361204	2	4" Retainer Strip
7	711715	4	Retaining Ring - Ext. .75	37	710255	7	10-32 x .62 Truss Head Screw
8	361023	1	Left Side Plate	38	361203	1	6" Rubber Flap
9	72-416-10	33	1/4-20 x 5/8 HH T.C.	39	361205	1	6" Retainer Strip
10	711227	6	5/16-18 x 5/8 HH Bolt	40	711350	4	10-32 Hex Nyloc Nut
11	711373	32	1/4-20 Nyloc Hex Nut	41	361244	1	Latch Catch
12	711621	2	3/8 OD x 3.5 Lg. Rollpin	42	361248	1	Latch Bracket
13	76-58-A	2	Roller	43	711304	2	8-32 Nut
14	361197	1	Axle Holding Bracket Assy.	44	711301	2	6-32 Nut
15	833289	4	Bearing Flange	45	710203	2	6-32 x .375 Screw
16	881059	2	Bearing, .75 ID w/Collar	46	710528	2	8-32 x .375 Flat Head Screw
17	711374	6	5/16-18 Nyloc Hex Nut	47	361054	1	Rubber Flap
18	361004	1	Differential	48	361055	1	Flap Holding Bar
19	361044	1	Brush Guard	49	712536	6	1/4-20 x .5 Screw
20	361074	1	Dust Cover Bracket	50	712638	6	1/4-20 Nyloc Nut
21	361051	1	Rear Brush Guard	51	361047	1	Dust Cover
22	361064	1	Caster Bracket Weldment	52	361049	1	Rubber Flap
23	711545	8	5/16 Helical Washer	53	361048	1	Flap Retainer Strip
24	711228	8	5/16-18 x 3/4 HH Bolt	54	712822	3	10-24 x .50 Screw
25	361003	1	6" Caster	55	361019	1	Mounting Bracket
26	361022	1	Right Side Plate Weldment	56	850028	2	Wheel Cover
27	361053	1	Triangle Support	57	711207	4	1/4-20 x 1.00 HH Bolt
28	712565	5	1/4-20 x 5/8 Truss Head Screw	58	760594	1	Spring
29	361052	1	Front Hopper Support	59	361302	1	Bumper, Side Broom
30	711506	4	5/16 Flat Washer	60	712042	4	BLT-WSR HH 5/16-18 x .62 #5

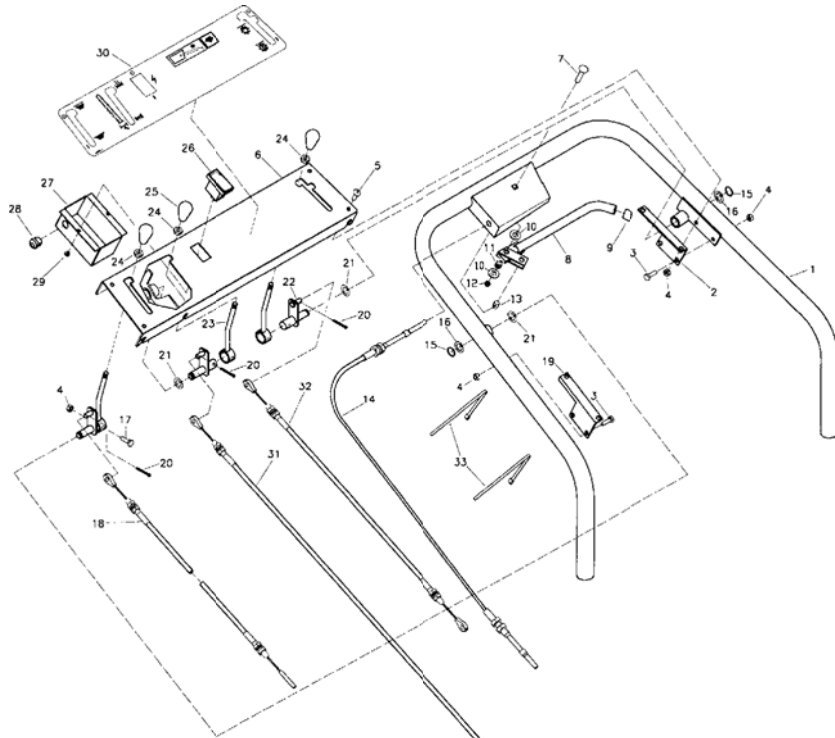

Parts List

Item	Part No.	Qty.	Description
1	361184	1	Handle
2	361134	1	Dashboard Bracket L.H.
3	711202	4	Bolt-HH 1/4-20 x .50 STPL
4	711373	11	Nut-Nyloc 1/4-20
5	710180	4	SCR-MC 1/4-20 x .75 STPL
6	361185	1	Dashboard
7	711256	1	Bolt, CR 5/16-18 x 1.5 S.S.
8	361145	1	Drive Handle Weldment
9	361232	1	Handle End Cover
10	711515	2	WSR-Flat .406 x .812 x .062
11	361217	1	Compression Spring
12	711383	1	Nut-Hex Ctr. Loc 5/16-18
13	361100	1	Drive Handle Swivel
14	361192	1	Cable, Traction Drive
15	711713	3	Retaining Ring - E Ext. .50
16	711594	3	WSR-Flat .56 x .88 x .03
17	711212	3	BLT-HH 1/4-20 x 1.50
18	361191	1	Cable, Broom Lift
19	361133	1	Dashboard Bracket R.H.
20	809311	3	Cotter Pin 7/64 Dia. x 1
21	711524	3	WSR-Wave .515 x .870 x .01
22	361122	3	Lever Pin Weldment
23	361124	3	Lever Weldment
24	711319	3	Nut-Hex 5/16-18 STPL
25	760592	3	Knob, Oval Tapered
26	742203	1	Switch, Carling Type V
27	361139	1	Switch Box
28	380032	1	Strain Relief, Round
29	711372	2	Nut, Nyloc 8/32
30	715389	1	Decal, Dashboard
31	361190	1	Cable, Shaker
32	361189	1	Cable, Brush Drive
33	361218	3	Cable Tie Large

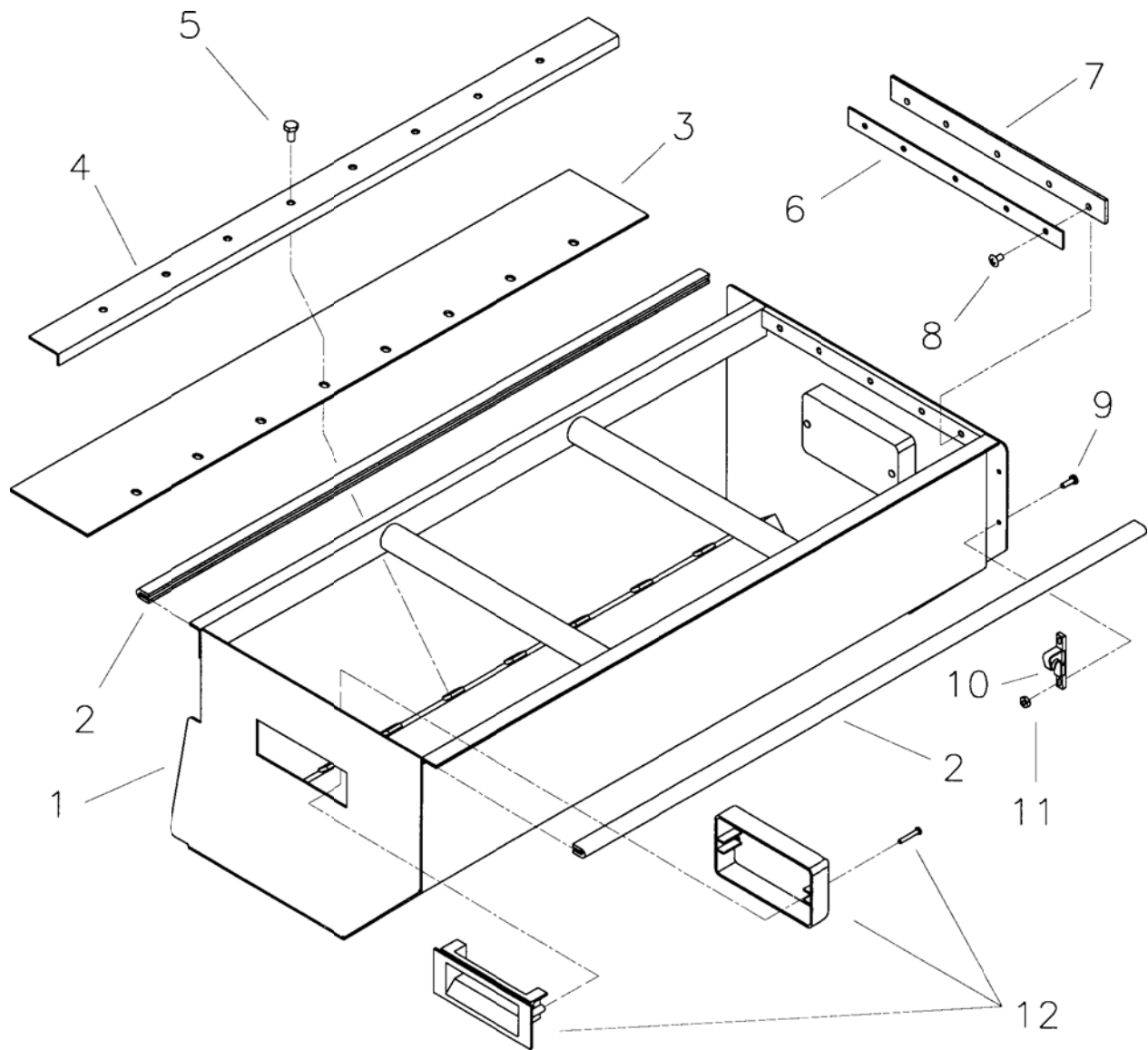

Parts List

Item	Part No.	Qty.	Description
1	361154	1	Hopper Weldment
2	361262	2	Edging
3	361159	1	Hopper Flap
4	361160	1	Flap Flange
5	711202	8	1/4-20 x .5 HH Screw
6	361173	1	Seal Plate
7	361172	1	Hopper Seal
8	712816	5	10-24 x .37 Screw
9	710329	2	8-32 x .5 Screw
10	361245	1	Latch Keeper
11	711372	2	8-32 Nyloc Nut
12	361175	2	Pocket Pull

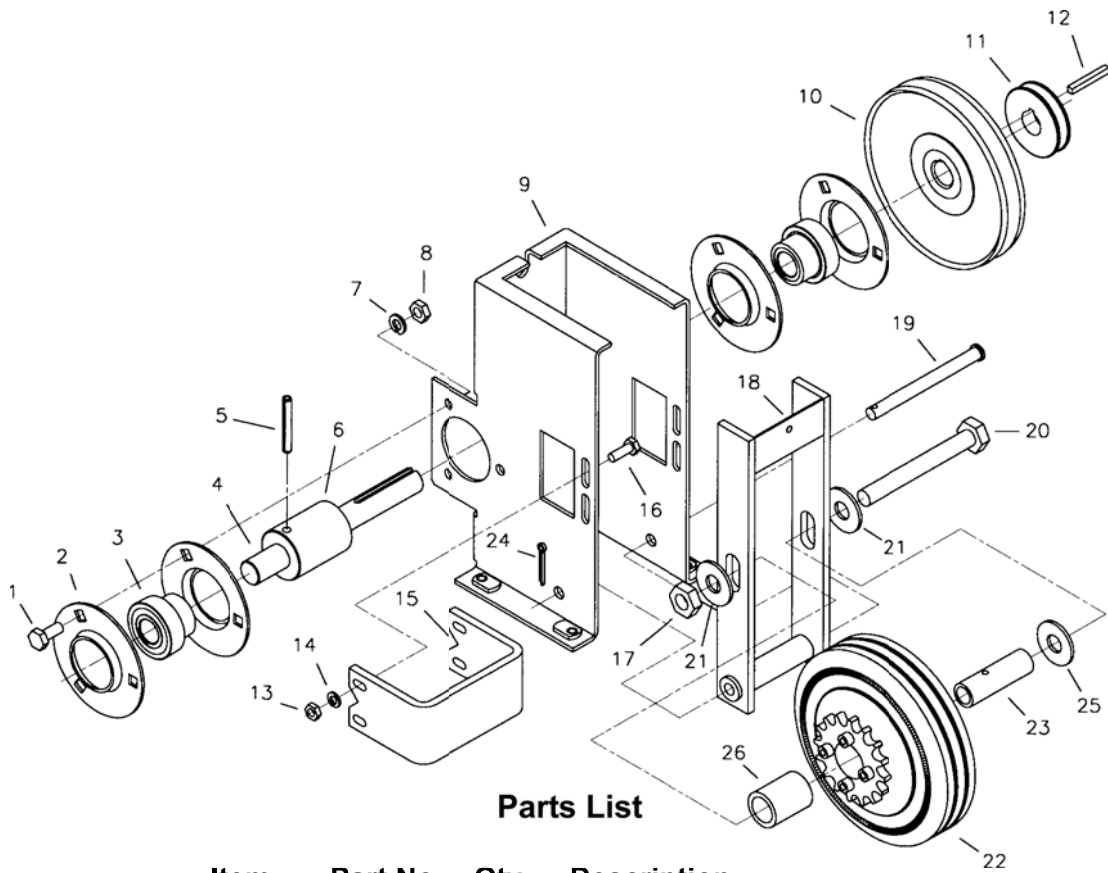

Parts List

Item	Part No.	Qty.	Description
1	711228	6	5/16-18 x 3/4 HH Bolt
2	833289	4	Bearing Flange
3	881059	2	Bearing .75 ID w/Collar
4	361164	1	Shaft
5	711904	1	.25 x 1.5 Rollpin
6	361165	1	Traction Drive Roller
7	711545	6	5/16 Helical Washer
8	711319	6	5/16-18 Hex Nut
9	361162	1	Traction Drive Bracket
10	361178	1	Traction Drive Pulley
11	361144	1	Pulley, 3L 2 OD x 3/4 ID
12	361233	1	3/16 x 3/16 x 1.5 Key
13	711316	4	1/4-20 Hex Nut
14	711544	4	1/4 Helical Washer
15	361163	1	Brake Bracket
16	711204	4	1/4-20 x 3/4 HH Bolt
17	711376	1	1/2-13 Nyloc Nut
18	361166	1	Pivot Arm Weldment
19	361193	1	3/8 x 4-1/4 Clevis Pin
20	712111	1	1/2-13 x 4.25 HH Bolt
21	712303	2	.56 x 1.375 x .10 Flat Washer
22	361226	1	Clutch Wheel Assembly
23	361211	1	Bearing Tube
24	809311	1	Cotter Pin
25	711594	1	Washer, Flat .56 x .88 x .03
26	361275	1	Bushing

TRACTION DRIVE ADJUSTMENT

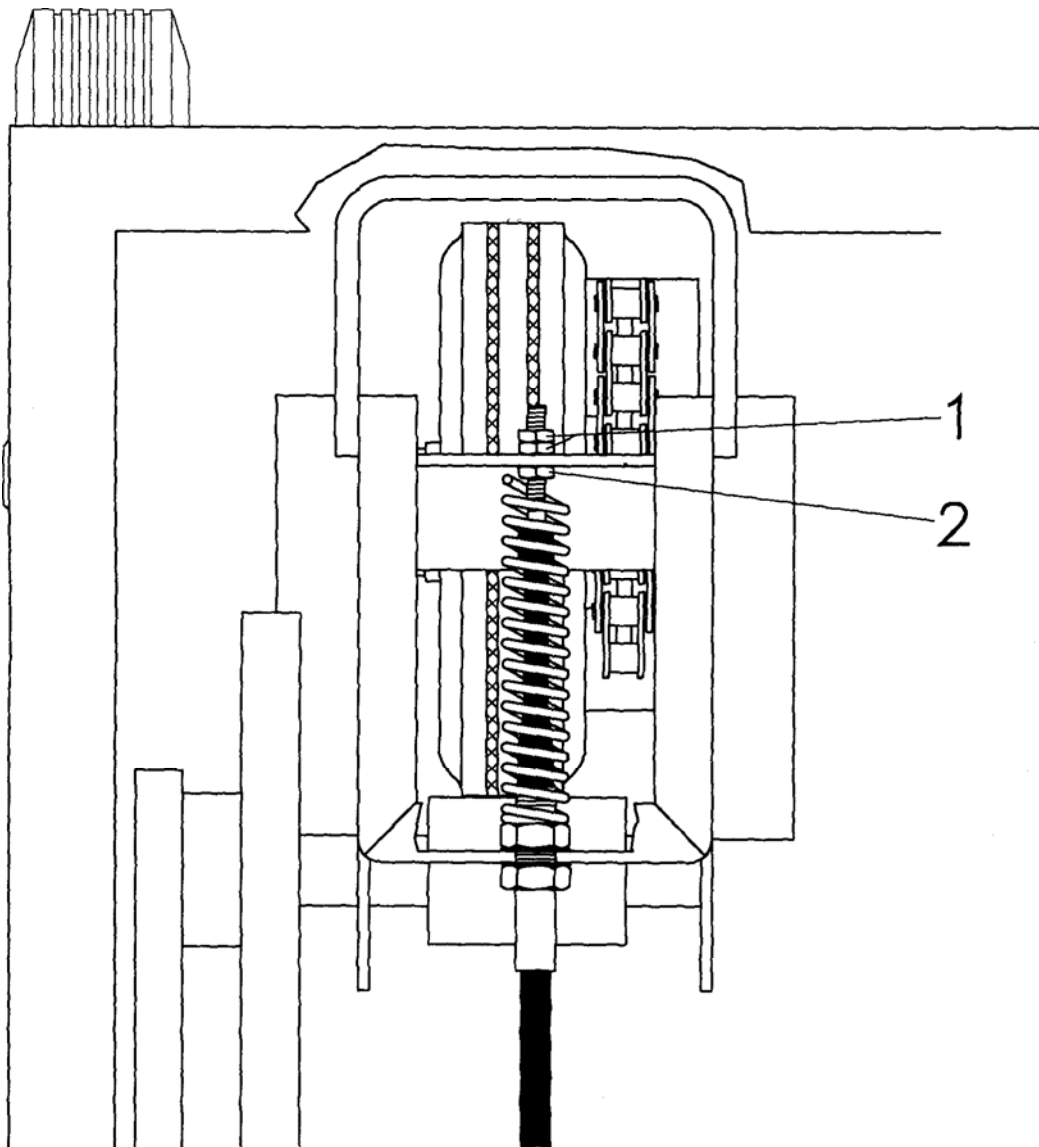

To adjust drive system loosen nuts 1 and turn nut 2 clockwise to increase forward speed. Counterclockwise to decrease.

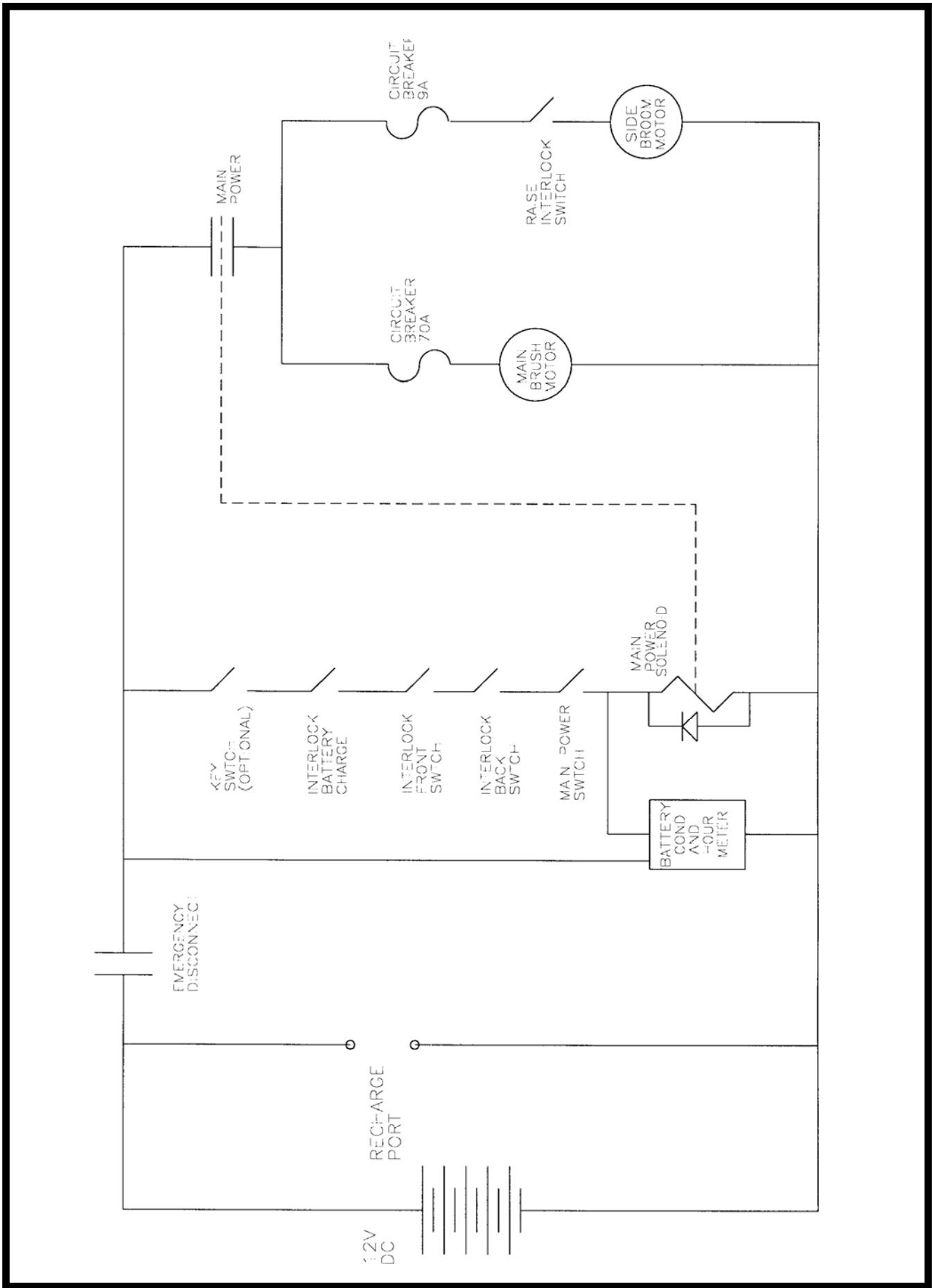

LIMITED WARRANTY

Minuteman International, Inc. warrants to the original purchaser/user that this product is free from defects in workmanship and materials under normal use and service for a period of one year from date of purchase. In addition, Minuteman International, Inc. will, at its option, honor labor warranty claims for the first 12 months from date of sale, provided such claims are submitted through and approved by factory authorized repair stations. Minuteman International, Inc. will, at its option, repair or replace without charge, except for transportation costs, parts that fail under normal use and service when operated and maintained in accordance with the applicable operation and instruction manuals.

This warranty does not apply to normal wear, or to items whose life is dependent on their use and care, such as belts, cords, switches, hoses, rubber parts, electrical motor components or adjustments. Parts not manufactured by Minuteman International, Inc. such as engines, batteries, battery chargers, hydraulic pumps, and tires are covered by and subject to the warranties and/or guarantees of their manufacturers. Please contact Minuteman International, Inc. for procedures in warranty claims against these manufacturers.

Special warning to purchaser — Use of replacement filters and/or prefilters not manufactured by Minuteman International, Inc. or its designated licensees, will void all warranties expressed or implied.

A potential health hazard exists without exact original equipment replacement.

All warranted items become the sole property of Minuteman International, Inc. or its original manufacturer, whichever the case may be.

Minuteman International, Inc. disclaims any implied warranty, including the warranty of merchantability and the warranty of fitness for a particular purpose. Minuteman International, Inc. assumes no responsibility for any special, incidental or consequential damages.

This limited warranty is applicable only in the U.S.A. and Canada, and is extended only to the original user/purchaser of this product. Customers outside the U.S.A. and Canada should contact their local distributor for export warranty policies. Minuteman International, Inc. is not responsible for costs or repairs performed by persons other than those specifically authorized by Minuteman International, Inc. This warranty does not apply to damage from transportation, alterations by unauthorized persons, misuse or abuse of the equipment, use of non-compatible chemicals, or damage to property, or loss of income due to malfunctions of the product.

If a difficulty develops with this machine, you should contact the dealer from whom it was purchased.

This warranty gives you specific legal rights, and you may have other rights which vary from state to state. Some states do not allow the exclusion or limitation of special, incidental or consequential damages, or limitations on how long an implied warranty lasts, so the above exclusions and limitations may not apply to you.

Minuteman[®]

World Headquarters
Minuteman International, Inc.
111 South Rohlwing Road
Addison, Illinois 60101

Minuteman Canada, Inc.
2210 Drew Road
Mississauga, Ontario
L5S 1B1

(630) 627-6900
FAX (630) 627-1130

(905) 673-3222
FAX (905) 673-5161

984006
Printed in U.S.A.