



Electronic Service Manuals

This electronic document is provided as a service to our customers. We do not create the contents of the information contained in this document. Should you have detailed questions pertaining to the information contained in this document, you may contact Michco, or the manufacturer which provided the original information in this electronic deliverable. Michco's only part in this electronic deliverable was the electronic assembly process. By providing this manual online we are not guaranteeing parts availability.

You may contact Michco through the following methods:

Phone (517) 484-9312

2011 N. High St. -- Lansing, Michigan -- 48906

Fax: (517) 484-9836

Email: CustomerService@Michco.com

Website: www.Michco.Com

Order Parts online at:

www.Michco.Com

Directly to Parts & Service:

By Email: **CustomerService@Michco.com**

By Fax: (517) 484-9836

By Voice: (517) 484-9312

Serving the Cleaning Industry Since 1922

Notice: All copyrighted material remains property of original owners, all trademarks are property of respective owners. Manuals are subject to Manufacturer's reproduction limitations. Originals or reproductions were provided by manufacturers through a request. We make no warranty as to the correctness of information provided in this document and you assume all risk. By placing these manuals on line we are not declaring our corporation to be an manufacturer authorized dealer or provider, please check our web site for authorized manufacturers we represent.



Parts Manual
Max Ride 28 Floor Scrubber
Orbital Brush Drive

PREFACE

Thank you for your purchase of the new industry standard for scrubbers. Minuteman International takes great pride in offering the most dependable, reliable and best value in industrial power sweepers and sweeper / scrubbers. We set the standard.

Our Customer Service Department would like to hear from you. If you see any errors, omissions or something that needs clarification in this Parts Catalog please let us know. We are working hard towards continually improving our processes to bring you the best you deserve. Please copy the form below, fill out and comment on how you found our catalog.

Thank you!
The Minuteman International Team

Name: _____

Title: _____

Company Name: _____

Address: _____

Country: _____

Type of equipment or model number: _____

Comments: _____

Please return to:
Customer Service Manager
Minuteman International, Inc.
14N845 U.S. Route 20
Pingree Grove, Illinois 60140 USA

Phone: (800) 323-9420
Email: tech@minutemanintl.com



Technical Specifications

Model Max Ride 28 Orbital
Models: MR28O, MR28OQP, MR28OQPG, MR28OINT, MR28OQPINT, MR28OQPGINT

MODEL	28 ORBITAL
Scrub Head Type	Orbital
Scrub Path	28 inches
Solution Capacity	21 gal (79.5L)
Recovery Capacity	23.5 gal (89L)
Max Productivity	35,739 sf/HR
Average Productivity	28,591 sf/HR
Pad Pressure	Floating 80lbs./110Nm
Pad Speed	2000 RPM
Pad Motor	550 Watts
Vacuum Airflow	65 cfm
Vacuum Water Lift	68" H2O
Sound Pressure	68 dba
Minimum Turn Around Aisle Width	55"
Maximum Ramp Climbing	2%
Squeegee Width	31.5" (80 cm)
Machine Voltage	24 VDC
Power Source	210AH Battery
Battery Charger	On Board
Maximum Run Time	3 - 3.5 hours
Dimension with Squeegee	52" x 31.5" x 45"
Weight / W-batteries	372 / 720 lbs

For Safety When Servicing or Maintaining Machine

- Stop on level surface.
- Disconnect the power to the machine by pulling the red Battery Connector located under the recovery tank near the batteries.
- Avoid moving parts. Do not wear loose jackets, shirts, or sleeves when working on machine.
- Avoid contact with battery acid. Battery acid can cause burns. When working on or around batteries, wear protective clothing and safety glasses. Remove metal jewelry. Do not lay tools or metal objects on top of batteries.
- Do not clean machine with a pressure washer.
- Authorized personnel must perform repairs and maintenance. Use Minuteman supplied replacement parts.

TABLE OF CONTENTS

Technical Specifications	3
Battery and Charger Options.....	5
Frame Group (Pg 1 of 2)	6
Frame Group (Pg 2 of 2)	7
Tower Group	10
Tank Group (Pg 1 of 2)	12
Tank Group (Pg 2 of 2)	13
Electrical Panel Assembly	16
Steering Column Group.....	18
Scrub Head Group.....	20
Scrub Head Lift Group.....	22
Squeegee Group	24
Squeegee Lift Group	26
Warranty	28

Battery and Charger Options

MODEL	BATTERY	CHARGER
MR28O	N/A	957764-2
MR28OQP	956705	957764-2
MR28OQPG	956748	957764-4
MR28OINT	N/A	957764-2
MR28OQPINT	956705	957764-2
MR28OQPGINT	956748	957764-4

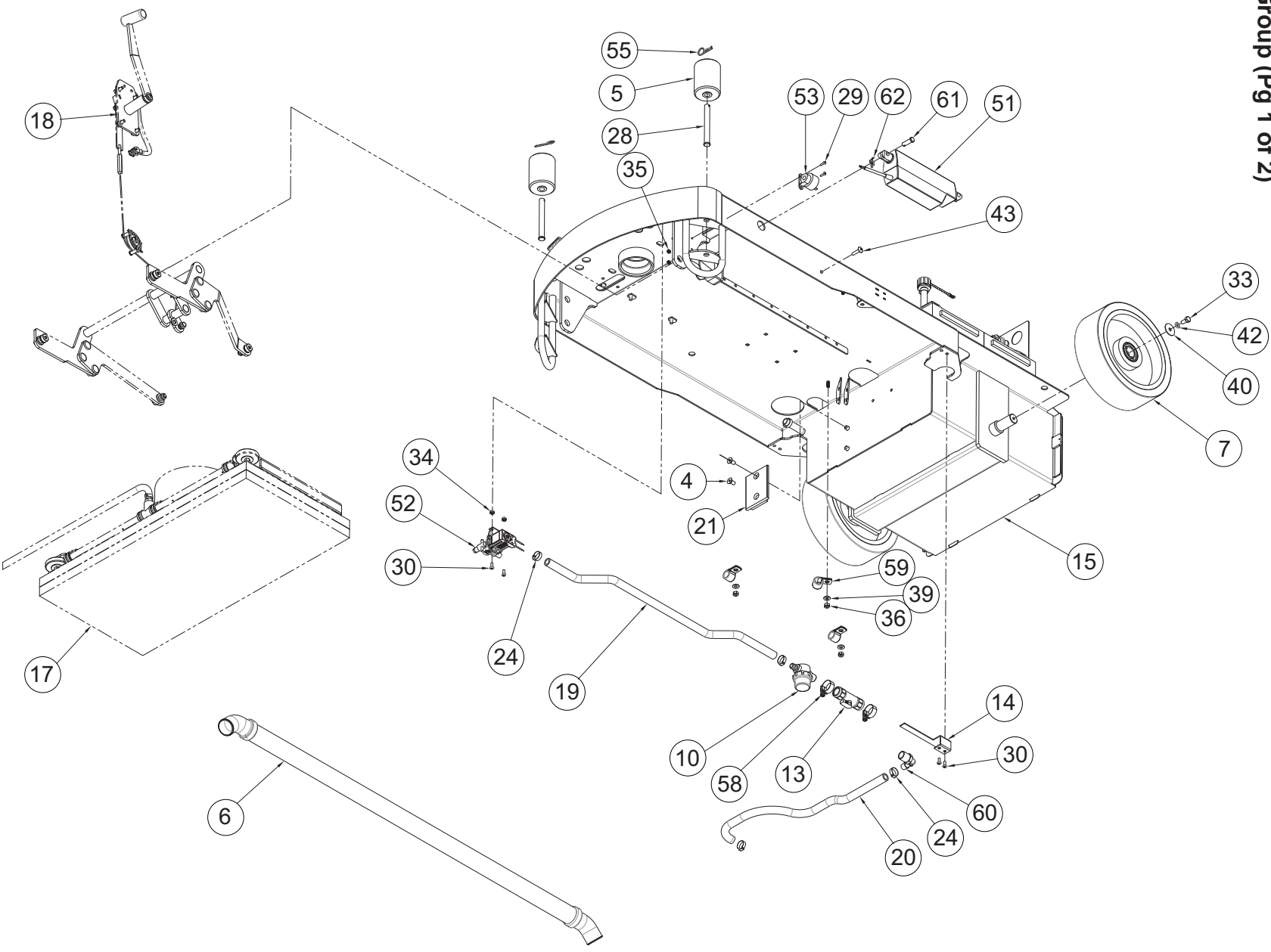

Rev B

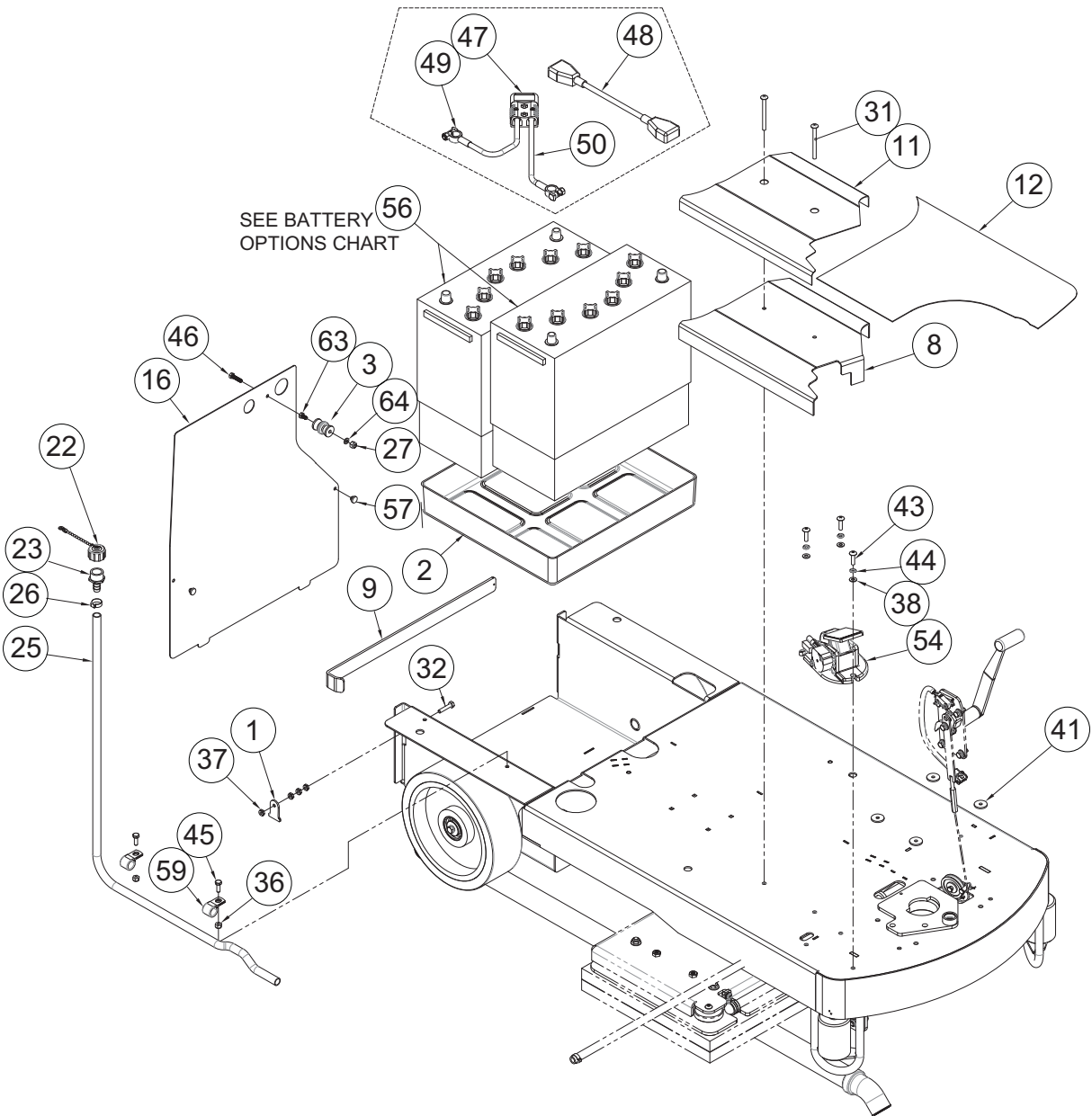

BILL OF MATERIAL - 246659			
ITEM	PART NO.	QTY	DESCRIPTION
1	245213	1	RETAINER-BATTERY BAR
2	245216	1	BOX-BATTERY-MAX 26
3	245222	1	LATCH-RUBBER
4	245338	2	SCR-FHSCS 5/16-18 X 5/8 SS
5	245419	2	ROLLER, BUMPER, 2.5 DIA.
6	245450	1	HOSE-VAC, CLEAR 1.50"ID X 43 LONG
7	245461	2	WHEEL - ASSY, IDLER, 254 X 80 W/BRGS
8	245570	1	WELDMENT, RISER, 26"
9	245662	1	BAR, BATTERY RETAINER
10	245781	1	FILTER - 1/2 MPT X 1/2 HB
11	245803	1	TREAD, ANTI-SKID, RISER 26"
12	245804	1	TREAD, ANTI-SKID, FRAME 26"
13	245845	1	VALVE- BALL 1/2 FPT X 1/2 FPT
14	246073	1	PLATE - MTG - BALL VALVE AND FILTER
15	246540	1	WELDMENT, FRAME, 26
16	246549	1	COVER, REAR 26
19	246650	1	TUBING, .50 ID X .13 WAL BRA VIN 28.0 IN
20	246651	1	TUBING, .50 ID X .13 WAL BRA VIN 22.0 IN
21	246758	1	BLOCK SLIDE
22	283690	1	ASSY, BREATHER CAP W LANYARD
23	342445	1	FTG-GARDEN ST 1/2 HB PP
24	383347	5	CLAMP-CRIMP 1/2 HOSE
25	430232	1	HOSE, 1/2 ID X 48", CLEAR
26	450076	1	CLAMP-HOSE 5/8 (.590-.791) SS
27	600933	1	NUT-NYLOC M6-1.00 SS
28	620027	2	PIN-CLEVIS 1/2 X 4.50 ZP
29	710204	2	SCR-PHMS 6-32 X .50 ZP
30	710355	4	SCR-RHMS 10-32 X .50 ZP
31	710592	2	SCR-THMS 1/4-20 X 3.00 SS
32	711210	1	SCR-HH 1/4-20 X 1.25 ZP GR 5 FULL THRD
33	711227	2	SCR-HH 5/16-18 X .62 ZP GR 5

Frame Group BOM (Pg 2 of 2)

BILL OF MATERIAL - 246659			
ITEM	PART NO.	QTY	DESCRIPTION
34	711350	2	NUT-NYLOC 10-32 ZP
35	711371	2	NUT-NYLOC 6-32 ZP
36	711373	5	NUT-NYLOC 1/4-20 ZP
37	711387	4	NUT-JAM 1/4-20 ZP NYLOC
38	711504	3	WASHER-FLAT 1/4 SS
39	711505	5	WASHER-FLAT 1/4 ZP
40	711516	2	WASHER-FLAT 5/16 X 1.25 X .05 ZP
41	711529	4	WASHER-RUBBER .25 x 1.00 x .110
42	711545	2	WASHER-LOCK 5/16 SPLIT ZP
43	712541	4	SCR-THMS 1/4-20 X 1.00 SS
44	712758	3	WASHER-LOCK 1/4 SPLIT SS
45	713002	2	SCR-HH 1/4-20 X .75 ZP 5
46	731006	1	SCR-HH M6-1.00 X 25 ZP CLASS 8.8
47	740159	1	CONNECTOR-SB175 RED HOUSING
48	740164-1	1	CABLE ASSY- BATTERY JUMPER, 4G RED 12"
49	740167	1	BATTERY CABLE, RED 4AWG SB175
50	740168	1	BATTERY CABLE, BLACK 4AWG SB175
51	740827-1	1	ACTUATOR - 40MM STROKE- 750 N FORCE TERM
52	247103-2	1	WATER VALVE ASSY, 24 VDC
53	748200	1	HORN / BACK UP ALARM, 9-48VDC
54	748507	1	PEDAL ASSY, THROTTLE, FLOOR MTG 25°, IEC
55	833374	2	PIN-HAIRPIN COTTER 3/8
56	****		SEE BATTERY CHART ON PAGE 5
57	3300526	2	BUMPER-RUBBER 1/4 ID X 1/8 THK
58	3300535	2	CLAMP-HOSE 1.00 NOM
59	3301158	5	CLAMP-CABLE 11/16" DIA
60	3315535	1	FTG-ELBOW 90 1/2 MPT X 1/2 HB PP
61	3400117	1	PIN-CLEVIS 3/8 x 1.125 ZP
62	3400125	1	RING-RUE 3/8
63	11038064	1	BLT-HH M6 X 1.0 X 12 STL ZD 8.8 DIN 933
64	12310033	1	WASHER-FLAT M6.4 X 12 X 1.6 ZP

Tower Group

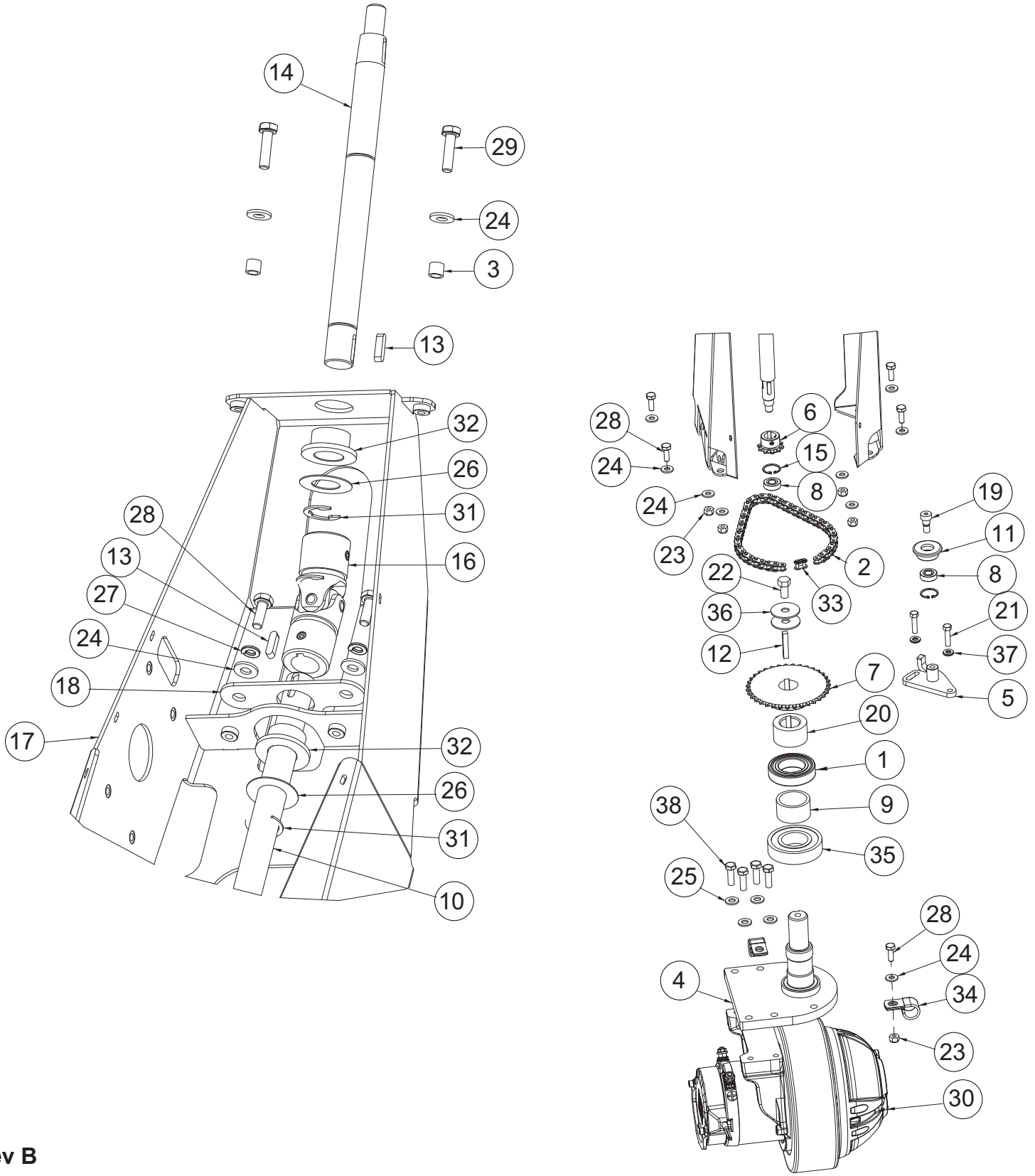

Rev B

Tower Group BOM

BILL OF MATERIAL - 246661			
ITEM	PART NO.	QTY	DESCRIPTION
1	245416	1	BALL BEARING 35MM X 62MM OD X 14MM W
2	245445-1	1	CHAIN - ROLLER #35
3	245583	2	SPACER, .266 B, .313 OD, .313 T
4	246022	1	SPINDLE WLDT, STEERING
5	246025	1	BRACKET WLDT, CHAIN TENSIONER
6	246028	1	SPROCKET, ANSI 35, 10 TOOTH, 0.375P, 0.62B
7	246029	1	SPROCKET, ANSI 35, 35 TOOTH, 0.375P, 1.00B
8	246030	2	BEARING, BALL, 0.375B, 0.875D, SEALED
9	246031	1	SPACER, 1.75D 1.44B .96L, STL
10	246033	1	SHAFT, LOWER STEERING
11	246034	1	GUIDE, CHAIN TENSIONER
12	246035	1	KEY, SQ, 0.25 X 0.25 X 1.50
13	246036	3	KEY, SQ, 0.18 X 0.18 X 0.75
14	246037	1	SHAFT, UPPER STEERING
15	246038	2	RING, RTNR, FOR .875 BORE, STL
16	246039	1	U-JOINT, 25DEG, 0.75B 1.06D 3.75L
17	246040	1	TOWER WELDMENT, STEERING
18	246042	1	PLATE, BEARING, STEERING
19	246067	1	BLT-SHOULDER .375 X .312 LG BLK OX
20	246771	1	PIVOT, STEERING STOP
21	711207	2	BLT-HH 1/4-20 X 1.00 STPL
22	711241	1	SCR-HEX 3/8 -16X .75" ZP
23	711373	5	NUT-NYLOC 1/4-20
24	711505	13	WASHER-FLAT 1/4 ZP
25	711506	4	WSR-FLT .344 X .690 X .062, STEEL
26	711517	2	WSR- FLAT .75X1.375X.09 SS
27	711544	2	WSR-HELICAL 1/4
28	713002	7	SCR-HH 1/4-20 X .75 ZP 5
29	713003	2	BLT-HH 1/4-20 X 1 #5
30	748523-1	1	WHEEL DRIVE, 24V 300W
31	809148	3	RET RING-E TYPE .75
32	832554	2	BUSHING-FLG .7505 X 1.437 X .625 BRNZ
33	833292	1	CHAIN MASTER LINK #35
34	3301158	2	CLAMP-CABLE 3/4
35	3305667	1	BEARING-MAIN BROOM
36	3400092	2	WASHER-FENDER 3/8 ZP 1.5 OD X .07 THK
37	3401570-7W	2	WASHER-NORD-LOCK, 1/4, 0.53 OD, ZP
38	11038247	4	BOLT - HH, M8 X 1.25 X 25, STL, ZINC DICH

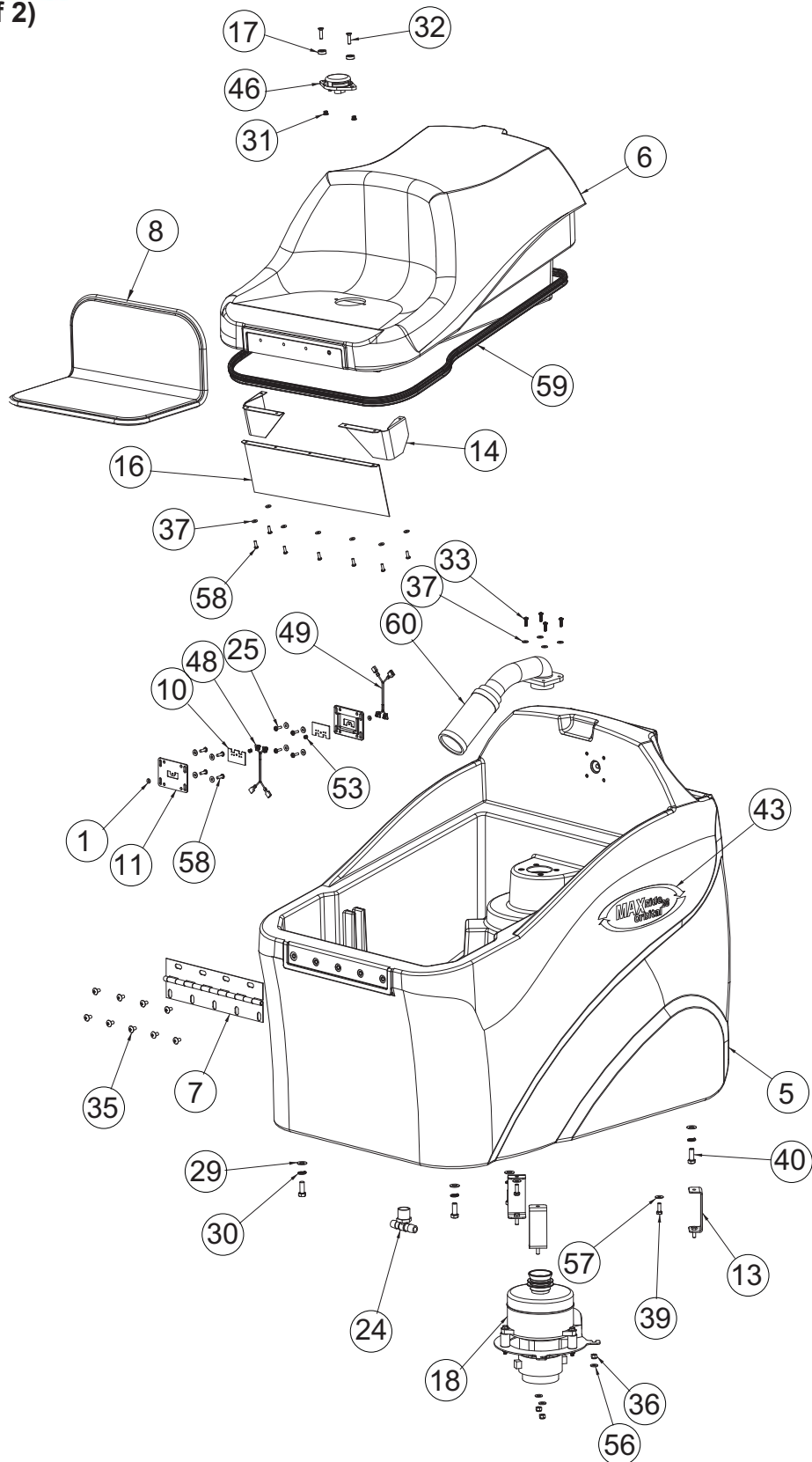

Rev C

Tank Group (Pg 2 of 2)

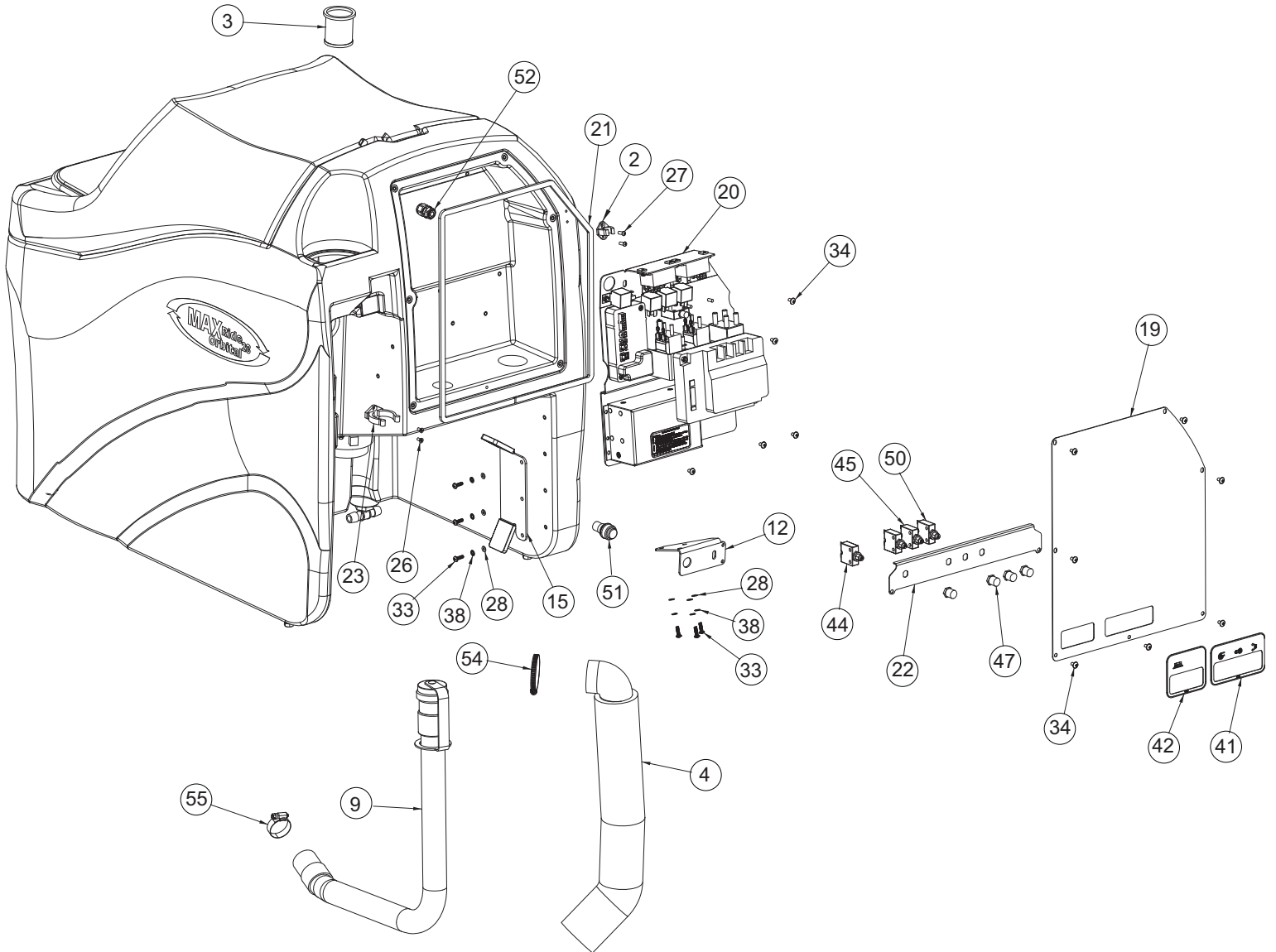

BILL OF MATERIAL - 246660			
ITEM	PART NO.	QTY	DESCRIPTION
1	950-4-S	2	BACKUP PLATE - RIVET
2	172065	1	CLIP, FOR 1/2" ID HOSE
3	172159	1	FILTER, FILL PORT, ES1720
4	241049	1	VAC MOTOR MUFFLER, SCV 24/26
5	245004	1	TANK, SOLUTION & RECOVERY ER26-V
6	245005	1	LID, W/ SEAT, TANK, ER26-V
7	245422	1	HINGE, STEEL, 11.38" LONG
8	245444	1	SEAT-CUSHIONED, SEWN SEAT & BACK
9	245452	1	HOSE-DRAIN W/ TWIST VALVE 1.50" ID
10	245453	2	PLATE - INSERT, INTERCONNECT
11	245456	2	PLATE - BASE, INTERCONNECT
12	245660	1	BRACKET - MTG, REAR COVER LATCH & ELEC
13	245663	3	WELDMENT, VAC MOTOR PILLAR
14	245766	2	SKIRT-DRIP, LID, END PIECE
15	245794	1	HOLDER - CORD, W/ SOFT CAPS, BATT CHARGR
16	245805	1	SKIRT - DRIP, LID, CENTER 26"
17	245817	2	SPACER, .39 ID X .75 OD X .25 T, PVC
18	245844	1	ASSY, VACUUM & HOUSING
19	245911	1	COVER, ELECTRICAL, 26 ECO
20	246190	1	ASSY, ELECTRICAL PANEL, ORB
21	246184	1	GASKET, ELECTRICAL PANEL
22	246778	1	BRACKET, BREAKER ORB 28
23	260579	1	TOOL CLIP, 1.5" HOSE
24	342440	1	FITTING, TEE 3/4MPT 1/2BARB
25	710130	4	SCR-MC 8-32 X .62 NICKEL
26	710528	2	SCR-MC 8-32 X .37 FH - BR
27	711163	2	SCR-HI/LO #10-16 X 1/2
28	711502	6	WASHER-FLAT #8 ZP
29	711515	4	WSR-FLAT .406 X .812 X .0625
30	711546	4	WSR-HELICAL 3/8

Tank Group BOM (Pg 2 of 2)

BILL OF MATERIAL - 246660			
ITEM	PART NO.	QTY	DESCRIPTION
31	711962	2	NUT, 1/4-20, HIGH-TORQUE 12 POINT FLANGE
32	712153	2	SC-SHCS, 1/4-20 x 1.00 IN SS
33	712536	10	SCR-MC 10-24 X .62 TH SS
34	712540	12	SCR-MC TR HD 10-24 X .37 SS
35	712565	9	SCR-THMS 1/4-20 X .62 SS
36	712667	3	NUT-NYLOC 1/4-20 SS
37	712764	19	WASHER-FLAT #10 SS
38	712770	6	WSR INT LOCK #10A SS
39	713002	3	SCR-HH 1/4-20 X .75 ZP 5
40	713042	4	BLT-HH 3/8-16 X 1 #5
41	715535	1	DECAL, VAC, DRIVE, MOTOR-POWER
42	715537	1	DECAL, BRUSHES, ORBITAL
43	715971	2	DECAL, MAIN OVAL MAX-RIDE 28, ORBITAL
44	740221	1	CIRCUIT BREAKER-30AMP PUSH BUTTON
45	740247	2	CIRCUIT BREAKER-30AMP PUSH BUTTON
46	740601	1	SWITCH, SEAT, BOLT MOUNT
47	742748	4	CIRCUIT BREAKER BOOT
48	747349	1	WIRE ASSY, SEAT SWITCH
49	747350	1	WIRE ASSY, SEAT SW CONN
50	747609	1	CIRCUIT BREAKER-4.0AMP PUSHBUT
51	747614	1	INDICATOR, BATTERY CHARGE STATUS
52	747689	1	STRAIN RELIEF, CABLE DIA. .181-.312 #3210
53	827666	2	RIVET-POP 1/8 DOME HD, BLK ALUM BODY
54	3044112	1	CLAMP - HOSE, DIAM. 2.5" SS
55	3303255	1	CLAMP-HOSE 1 3/4 NOM.
56	3400089	3	WASHER 1/4 ID .63 OD X .065 THK
57	3400383	3	WASHER CONICAL SPRING 1/4
58	3401449	11	SCR-HI/LO SS 10-16X3/4 PAN HD PHL.
59	25510512	1	GASKET, RUBBER BLADE, PRESS IN
60	97118731	1	FILTER UNIT, SCREENED FLOAT

Electrical Panel Assembly

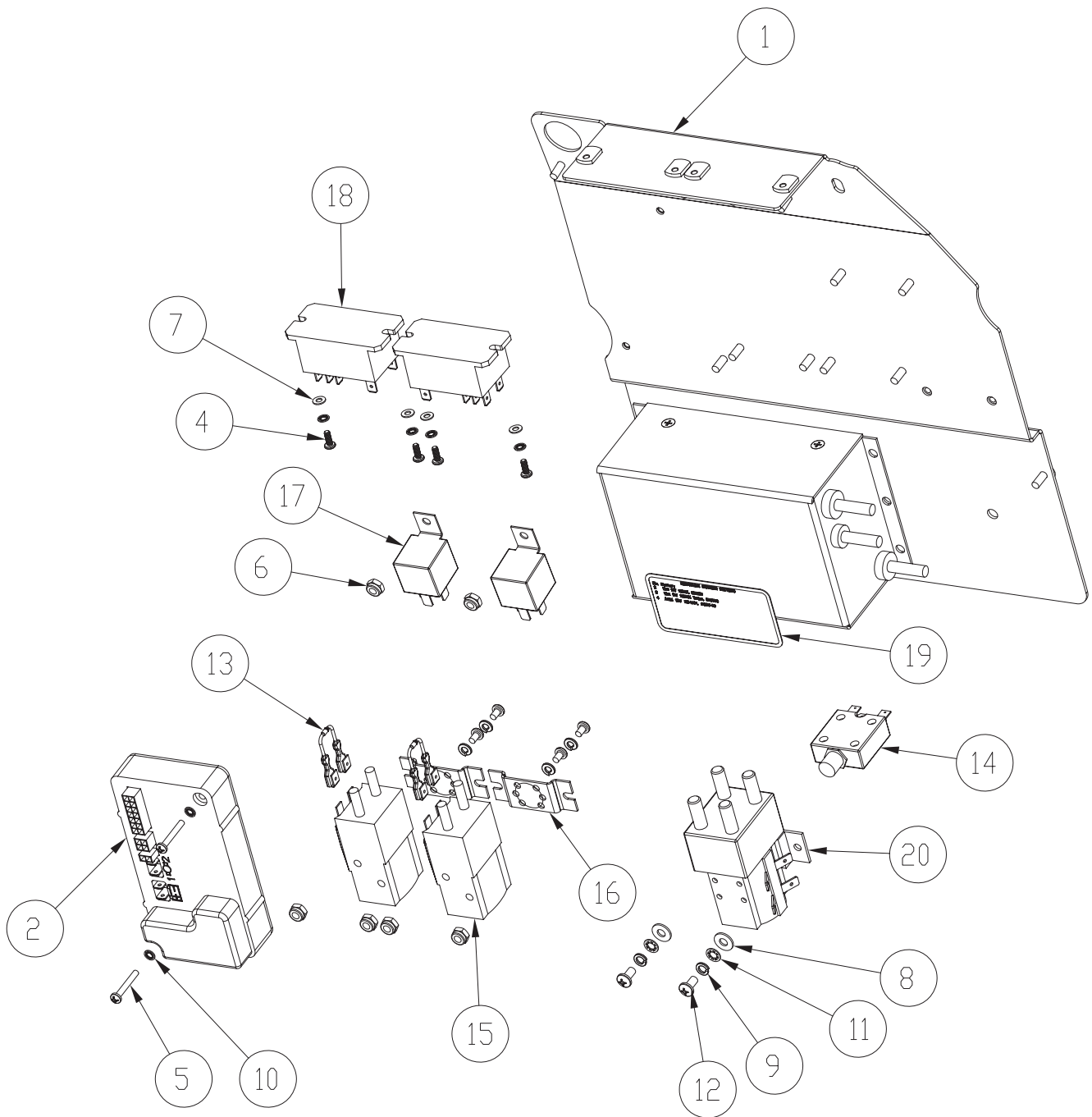

Rev A

Electrical Panel Assembly BOM

BILL OF MATERIAL - 246190			
ITEM	PART NO.	QTY	DESCRIPTION
1	245851	1	PANEL, ELEC CHASSIS, 20/26
2	246191	1	I-DRIVE, 24V 70A, MAX RIDE ORBITAL
3	747272	1	MR ELECT COMMON PARTS 20/28 ORBITAL
4	710203	4	SCR-PHMS 6-32 X .37 ZP
5	710307	2	SCR-PHMS 6-32 X 1.00 ZP
6	711350	6	NUT-NYLOC 10-32 ZP
7	711501	4	WASHER-FLAT #6 X .375 ZP
8	711503	2	WASHER-FLAT #10 X .50 ZP
9	711543	2	WASHER-LOCK #10 SPLIT ZP
10	711551	6	WASHER-INT LOCK #6
11	711553	2	WASHER-INT TOOTH LOCK #10 ZP
12	712810	2	SCR-RHMS 10-24 X .37 ZP
13	740482	2	DIODE ASY, 1N4007 W/PIGGY
14	740703	1	CIRCUIT BREAKER, 1 AMP
15	747616	2	RELAY, 24VDC 1 POLE NO 80A
16	747619	2	BRACKET, RELAY 747615 & 747616
17	748511	2	RELAY, SPDT, MAX RIDE
18	748524	2	RELAY, DPDT, 40A
19	957936	1	LABEL, FOR CHARGERS 957764
20	90331026	1	RELAY, 24VDC 2 POLE NO 125A

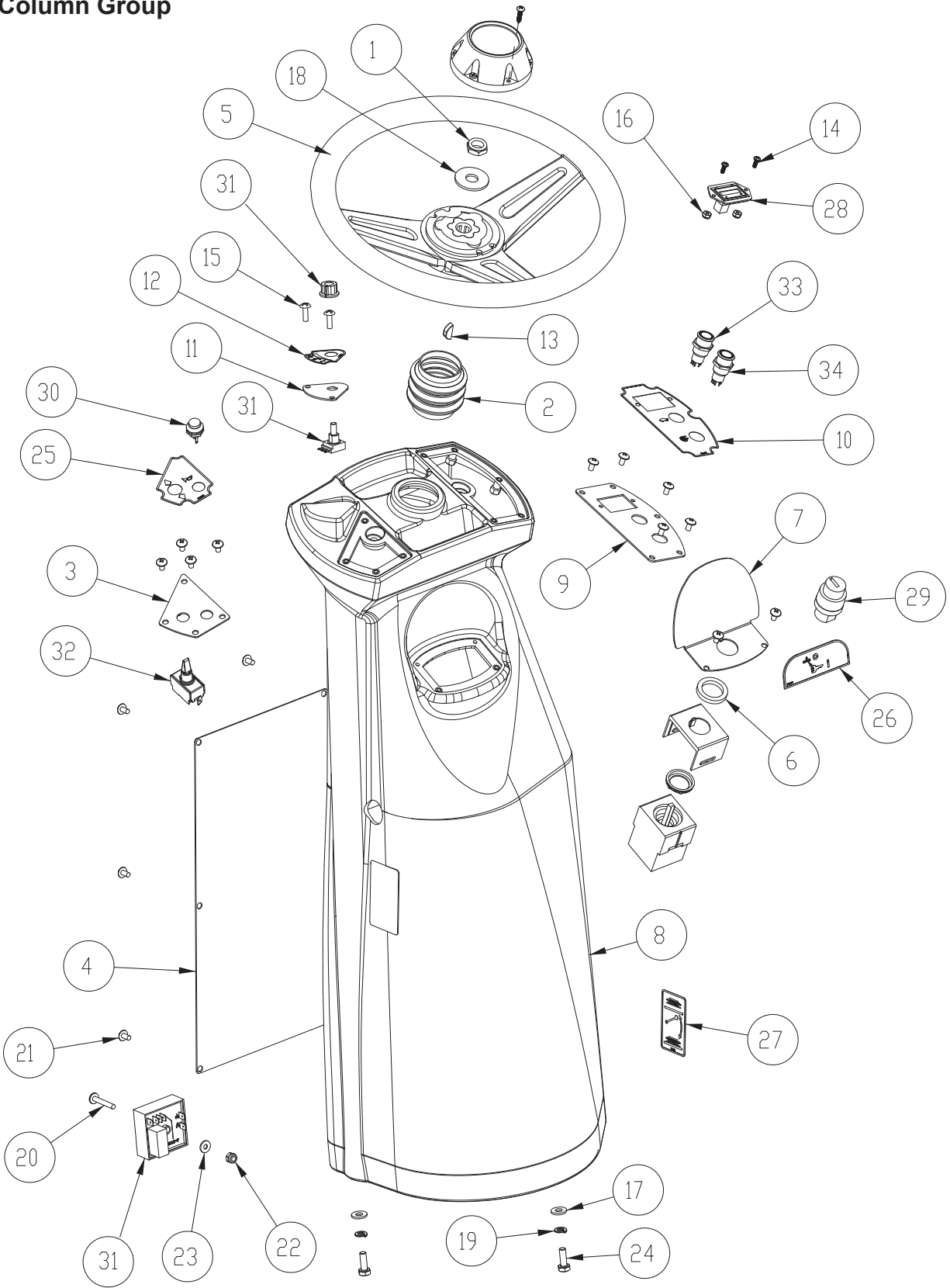

Rev B

Steering Column Group BOM

BILL OF MATERIAL - 246181			
ITEM	PART NO.	QTY	DESCRIPTION
1	368-816	1	HALF NUT NYLOC 1/2-20
2	241224	1	BOOT - SHAFT, SCV 2426
3	245028	1	PANEL-CONTROL, LH FWD-REV SELECTOR
4	245156	1	PANEL-FRONT STEERING CONSOLE
5	245345	1	STEERING WHEEL
6	245802	1	SPACER, PVC, KEY SWITCH
7	245840	1	PANEL, CENTER, KEY SWITCH
8	246182	1	CONSOLE, STEERING, ORBITAL
9	246814	1	PANEL-CONTROL RH, FUNCTION
10	246815	1	DECAL, FUNCTION SELECTOR
11	246816	1	PANEL, SOLUTION CONTROL
12	246817	1	DECAL, SOLUTION CONTROL
13	383277	1	KEY WOODRUFF 3/16 X 3/4
14	710203	2	SCR-MC 6-32 X .37 ST PL PAN HD
15	711160	2	#10 X 5/8 HI-LO
16	711371	2	NUT-NYLOC 6-32 ZP
17	711505	2	WASHER-FLAT 1/4 ZP
18	711510	1	WSR FLAT .5 X 1.37 X .100
19	711544	2	WSR-HELICAL 1/4
20	712533	1	SCR-MC 10-24 X 1.25 SS
21	712540	17	SCR-MC TR HD 10-24 X .37 SS
22	712638	1	NUT, HEX 10-24 SS NYLOC
23	712764	1	WASHER-FLAT #10 SS
24	713002	2	SCR-HH 1/4-20 X .75 ZP 5
25	715762	1	DECAL-FWD-REV SELECTOR
26	715778	1	DECAL, CENTER PANEL, KEY SWITCH
27	715781	1	DECAL, BRUSH LIFT, 20/26
28	747011	1	BATTERY GAUGE, TRUCHARGE
29	747387	1	KEYSWITCH ASSY
30	748047	1	SWITCH, PUSH BUTTON (HORN SCV 36V)
31	748537-1	1	ASSY, TIMER-RELAY 24V, 10 SEC, 10A
32	748800	1	SWITCH-TOGGLE G SERIES
33	748803	1	SWITCH, PUSH BUTTON, BLUE LED
34	748804	1	SWITCH, PUSH BUTTON, ORANGE LED

Scrub Head Group

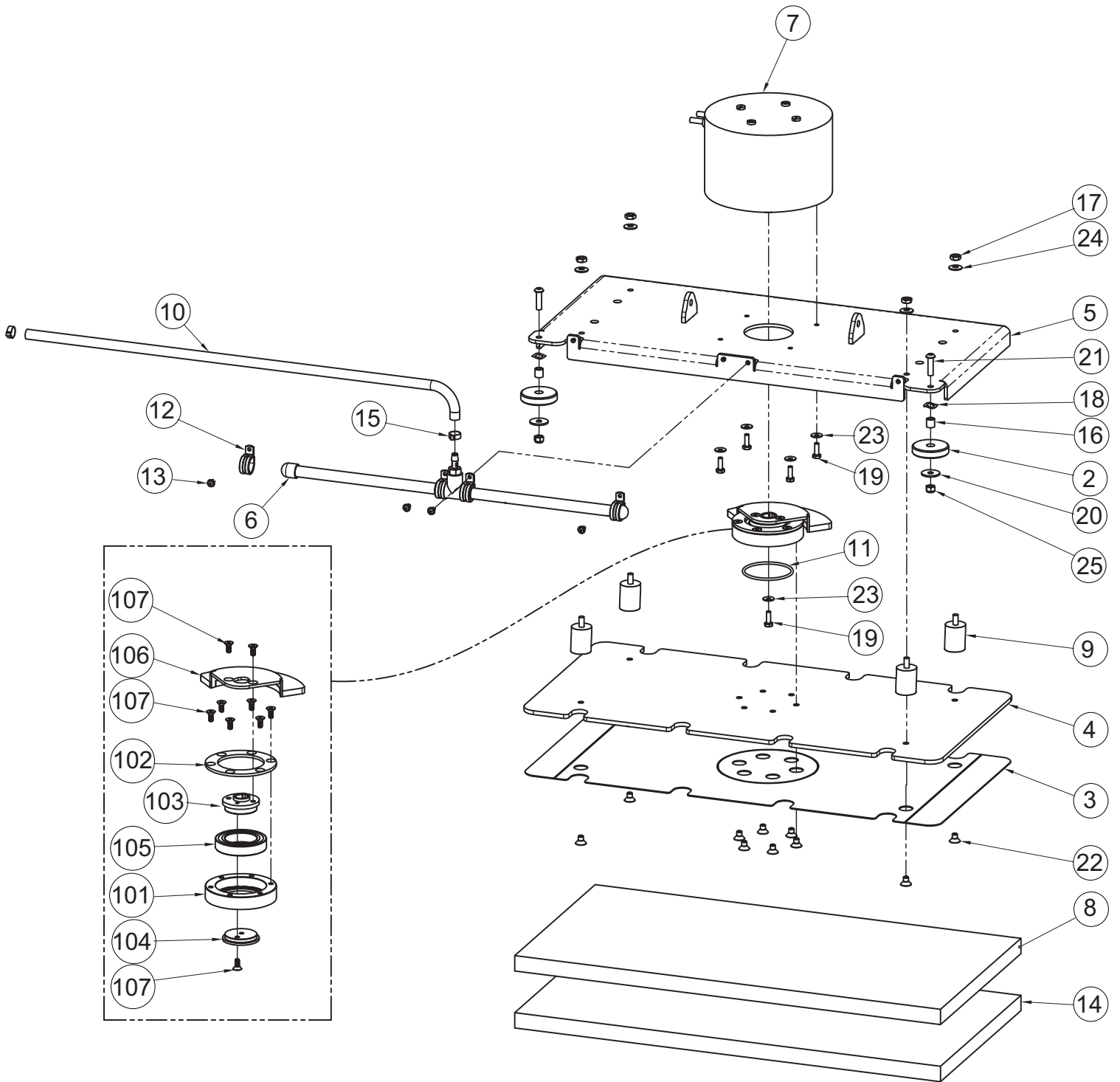

Rev B

Scrub Head Group BOM

BILL OF MATERIAL - 246575			
ITEM	PART NO.	QTY	DESCRIPTION
2	245339	2	ROLLER- SQUEEGEE
3	246550	1	FACE, 28
4	246558	1	PLATE, PAD DRIVER, 28
5	246559	1	WELDMENT, MOTOR MOUNT, 28
6	246563	1	MANIFOLD, 28
7	246564	1	MOTOR, 24VDC .75HP 2000RPM
8	246627	1	BACKER PAD, ORBITAL 28
9	246628	4	ISOLATOR
10	246652	1	TUBING, .38 ID X .11 WAL BRA VIN 29.5 IN
11	246739	1	O-RING 2.88 X 3.13 X .13 NBR
12	246740	4	CLAMP, .88 SS VIBRATION DAMPING
13	246741	4	SCR-PHMS 10-32 X .50 SS SEMS
14	246752	1	PAD-RED 28X14
15	452037	2	CLAMP-CRIMP 170R SS
16	600114	2	SPACER, .328 B .498 OD .500 ,SS
17	711319	4	NUT-HEX 5/16-18 ZP
18	711524	2	WASHER-WAVE .52 X .87 X .01
19	713002	5	SCR-HH 1/4-20 X .75 ZP 5
20	730526	2	WASHER-FENDER M8 X 24 SS
21	770536	2	SCR-BHSCS M8-1.25 X 30 SS
22	3400259	10	SCR-FHSCS 5/16-18 X.50 ZP
23	3400383	5	WASHER-CONICAL SPRING 1/4
24	3400384	4	WASHER-CONICAL SPRING 5/16
25	12040259	2	NUT-NYLOC M8 X 1.25 SS
101	246552	1	HOUSING, ECCENTRIC
102	246553	1	PLATE, OUTER BEARING RETAINER
103	246554	1	BEARING SHAFT MOUNT
104	246555	1	BEARING RETAINER, INNER
105	246557	1	BEARING, 50MM, SEALED
106	246644	1	WELDMENT, COUNTERWEIGHT, ORBITAL 20
107	246744	9	SCR-FHSCS 1/4-20 X .63 SS NYL PATCH

Scrub Head Lift Group

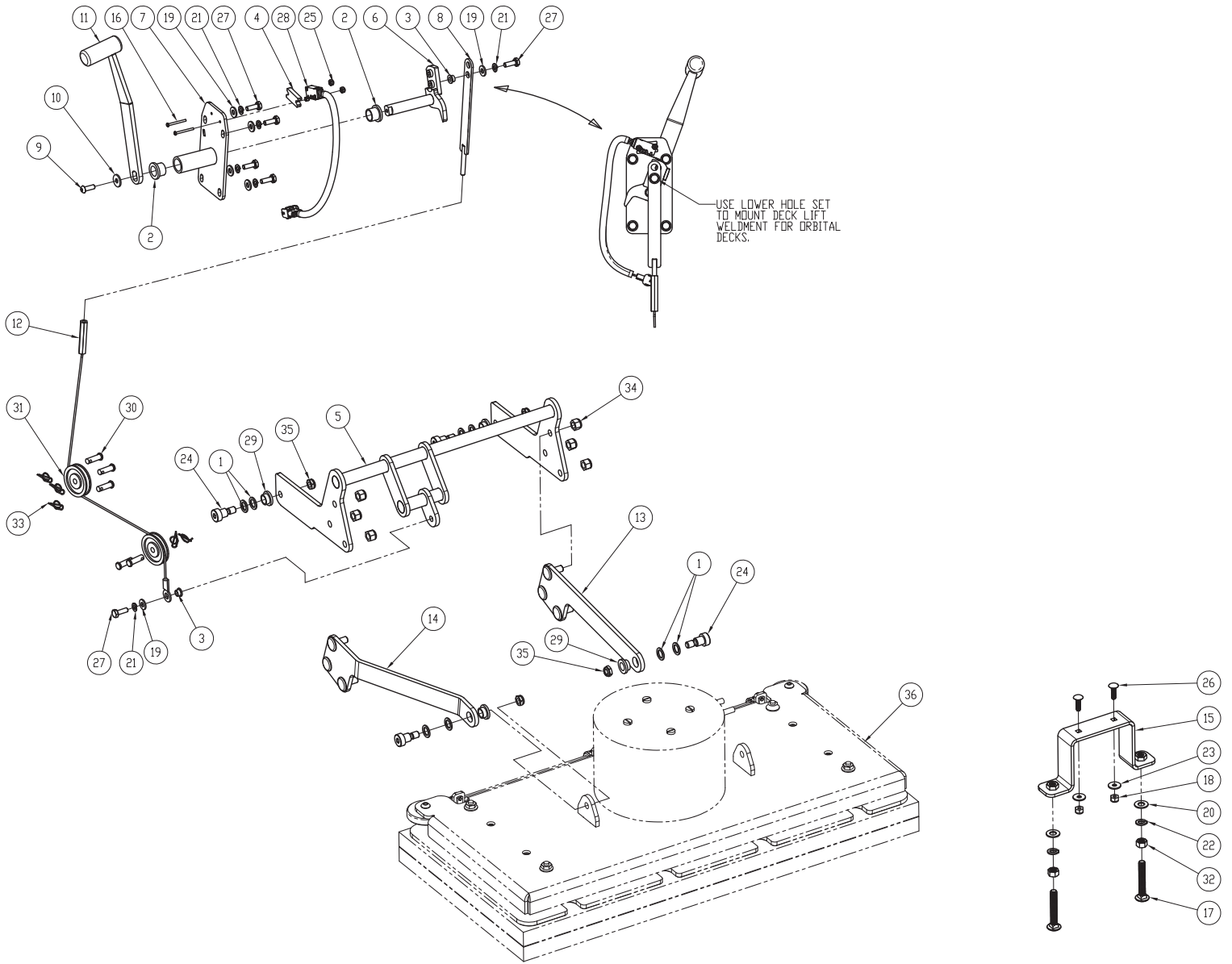

Rev D

Scrub Head Lift Group BOM

BILL OF MATERIAL - 246654			
ITEM	PART NO.	QTY	DESCRIPTION
1	246064	8	WASHER-FLAT 1/2 X .75 X .062 NYLON
2	246078	2	BUSHING, FLANGED 5/8" SHAFT DIA.
3	246079	2	BUSHING, FLANGED 1/4" SHAFT DIA.
4	246089	1	BRACKET, SWITCH
5	246541	1	WELDMENT, TRAILING ARM, 26
6	246631	1	WELDMENT, HEAD LIFT SHAFT
7	246647	1	WELDMENT, HEAD LIFT
8	246649	1	WELDMENT, DECK LIFT END
9	246730	1	SCR-BHSCS 1/4-20 X .75 BLK OX NYL PATCH
10	246731	1	WASHER-FLAT, .25 X .75 X .08, HARDEND
11	246736	1	WELDMENT, HEAD LIFT, HANDLE
12	246755	1	CABLE, DECK LIFT
13	246776	1	WELDMENT, EXTENSION ARM, ORBITAL, RIGHT
14	246777	1	WELDMENT, EXTENSION ARM, ORBITAL, LEFT
15	247040	1	WELDMENT, ORBITAL HEAD STOP
16	710495	2	SCR-PHMS 4-40 X 1.25 ZP
17	711254-1	2	BLT-CARR 3/8-16 X 2.50 ZP GR 5
18	711373	2	NUT-NYLOC 1/4-20 ZP
19	711505	6	WASHER-FLAT 1/4 ZP
20	711515	2	WASHER-FLAT 3/8 X .812 X .0625 ZP
21	711544	6	WASHER-LOCK 1/4 SPLIT ZP
22	711546	2	WASHER-LOCK 3/8 SPLIT ZP
23	711575	2	WASHER-FLAT 1/4 X .75 X .06 ZP
24	712009	4	BLT-SHLDR 1/2 X 1/2 LG X 3/8-16, PRECISE
25	712348	2	NUT-NYLOC 4-40 SS
26	712593	2	BLT-CARR 1/4-20 X .875 SS
27	713002	6	SCR-HH 1/4-20 X .75 ZP 5
28	747603-2	1	SWITCH ASY, MICRO ROLLER W/PACK/CONDUIT
29	762092	4	BUSHING-FLG, .50 X .62 X .375 LG OIL-EMB
30	881002	5	PIN-CLEVIS 5/16 X 1.00 ZINC
31	3300368	2	PULLEY-PLASTIC 2" x .25" GROOVE
32	3400068	2	NUT-HEX 3/8-16 ZP GR 5
33	3400125	5	RING-RUE 3/8
34	3400340	6	NUT-NYLOC 3/8-16 SS
35	3401028	6	NUT-JAM 3/8-16 ZP NYLOC
36	246575	4	SCRUB HEAD GROUP, ORBITAL 28" (REFERENCE)

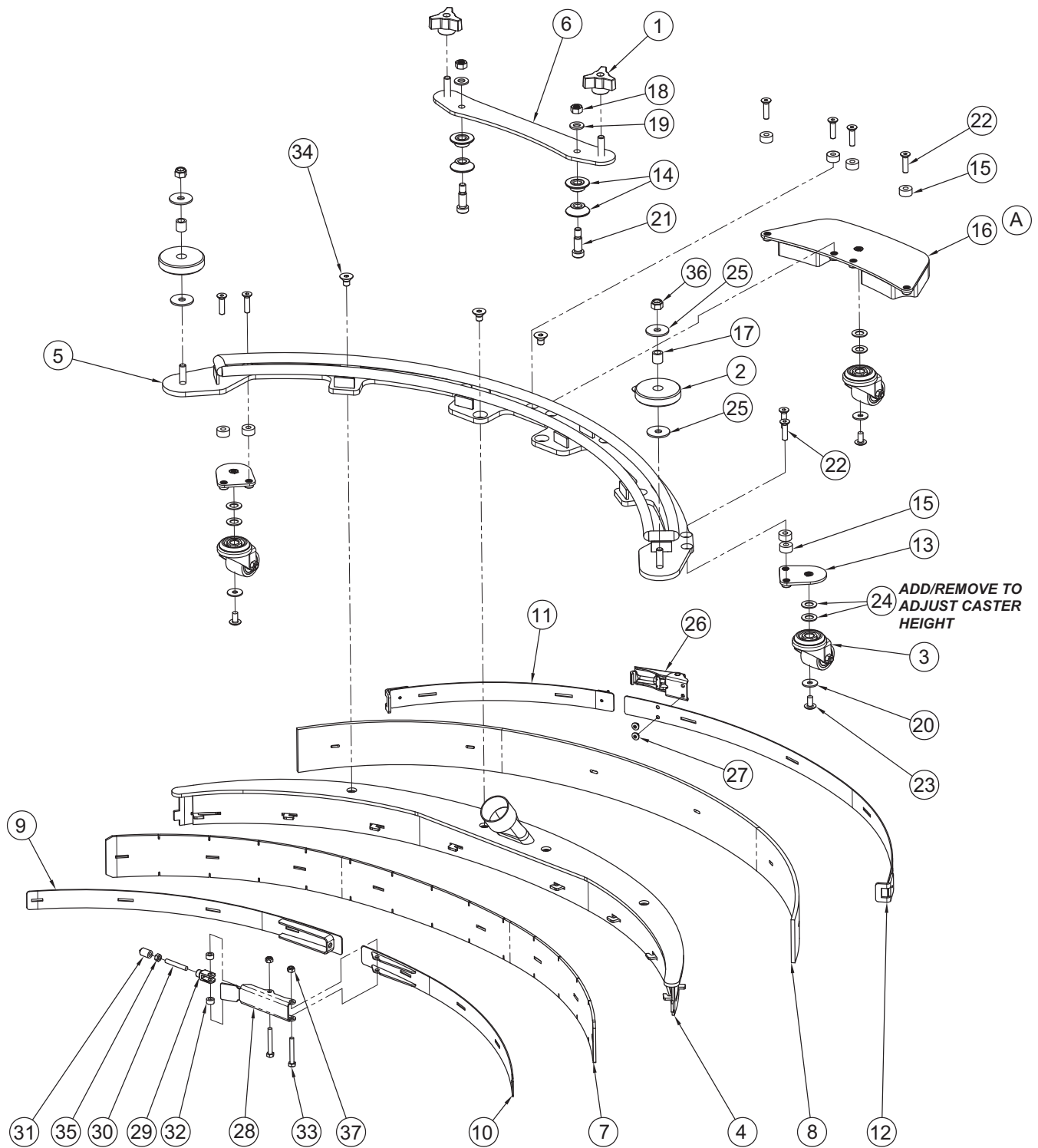

Rev A

Squeegee Group BOM

BILL OF MATERIAL - 246663			
ITEM	PART NO.	QTY	DESCRIPTION
1	210118	2	KNOB-3 SIDED 5/16 NYLOC
2	245339	2	ROLLER- SQUEEGEE
3	245563	3	CASTER
4	247026	1	WELDMENT, SQUEEGEE, ORB 28
5	247028	1	WELDMENT, SQUEEGEE RAIL, 28 ORB
6	247029	1	WELDMENT, RAIL ROLLER MOUNT
7	247030-1	1	SQUEEGEE BLADE, 28 INNER, PRIMOTHANE
8	247031-1	1	SQUEEGEE BLADE, 28 OUTER, PRIMOTHANE
9	247032	1	WELDMENT, INNER STRAP, CATCH
10	247033	1	WELDMENT, INNER STRAP, LATCH
11	247034	1	WELDMENT, OUTER STRAP, SHORT
12	247035	1	WELDMENT, OUTER STRAP, LONG
13	247036	2	WELDMENT, CASTER MOUNT
14	247037	4	ROLLER, RAIL
15	247038	8	SPACER, .252 B .625 OD .313T, ZP
16	247043	1	WELDMENT, CENTER CASTER MOUNT, 28
17	600114	2	SPACER, .328 B .498 OD .500 ,SS
18	711383	2	NUT-HEX 5/16-18 ZP REVERSE LOC
19	711506	2	WASHER-FLAT 5/16 X .688 ZP
20	711575	3	WASHER-FLAT 1/4 X .75 X .06 ZP
21	712081	2	BLT-SHOULDER 3/8 X .75 X 5/16-18 SS
22	712153	8	SCR-FHSCS 1/4-20 X 1.00 SS
23	712560	3	SCR-THMS 1/4-20 X .50 SS W/NYLON PATCH
24	712767	6	WASHER-FLAT .406 X .75 X .035 SS
25	730526	4	WASHER-FENDER M8 X 24 SS
26	730652	1	LATCH, UNDER CENTER
27	730654	2	RIVET-BLIND 5/32 .125 GRIP SS
28	730780	1	LATCH, BODY SS
29	730781	1	CLEVIS, M5 - 0.8
30	730782	1	ROD, M5 - 0.8
31	730783	1	ROD, NOSE
32	730784	2	SPACER, .203 B .375 OD .210 T
33	730802	2	SCR-HH M5-0.8 X 35 SS FULL THREAD
34	3400259	4	SCR-FHSCS 5/16-18 X.50 ZP
35	12022430	1	NUT-HEX M5 X 0.8 316SS DIN 934
36	12040259	2	NUT-NYLOC M8 X 1.25 SS
37	12040283	2	NUT-NYLOC M5 X 0.8 304SS DIN985

Squeegee Lift Group

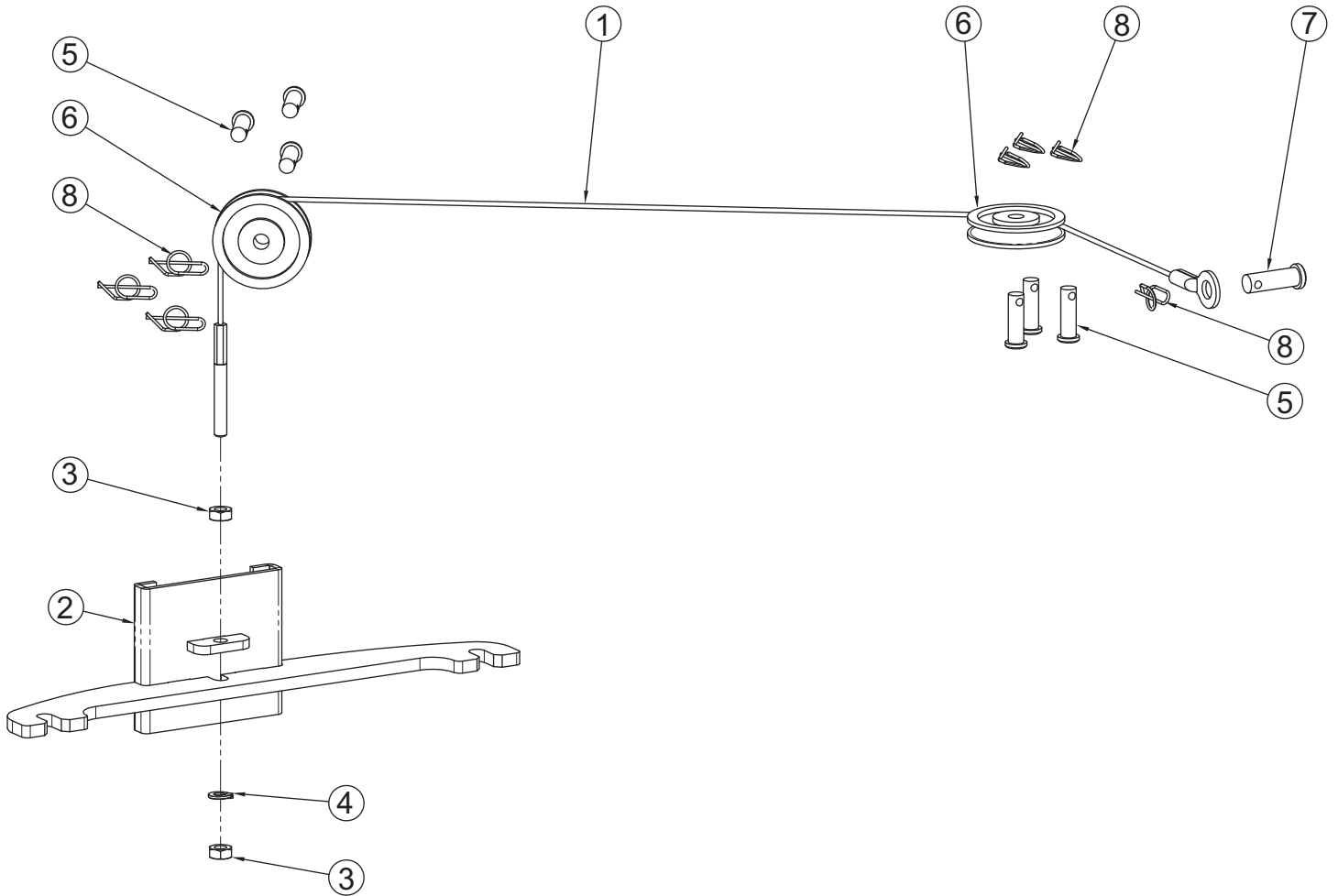

Rev A

Squeegee Lift Group BOM

BILL OF MATERIAL - 246664			
ITEM	PART NO.	QTY	DESCRIPTION
1	245498	1	CABLE-SQUEEGEE 26"
2	247027	1	WELDMENT, SQUEEGEE LIFT GUIDE, ORBITAL
3	712665	2	NUT-HEX 1/4-20 SS
4	712758	1	WASHER-LOCK 1/4 SPLIT SS
5	881002	6	PIN-CLEVIS 5/16 X 1.00 ZINC
6	3300368	2	PULLEY-PLASTIC 2" x .25" GROOVE
7	3400117	1	PIN-CLEVIS 3/8 x 1.125 ZP
8	3400125	7	RING-RUE 3/8

Minuteman International Made Simple Commercial Limited Warranty

REVISION P EFFECTIVE 5/1/2017

Minuteman International, Inc. warrants to the original purchaser/user that the product is free from defects in workmanship and materials under normal use. Minuteman will, at its option, repair or replace without charge, parts that fail under normal use and service when operated and maintained in accordance with the applicable operation and instruction manuals. All warranty claims must be submitted through and approved by factory authorized repair stations.

This warranty does not apply to normal wear, or to items whose life is dependent on their use and care, such as belts, cords, switches, hoses, rubber parts, brushes, electrical motor components or adjustments. Parts manufactured by Minuteman are covered by and subject to the warranties and/or guarantees of their manufacturers. Please contact Minuteman for procedures in warranty claims against these manufacturers.

Special warning to purchaser -- Use of replacement filters and/or pre-filters not manufactured by Minuteman or its designated licensees, will void all warranties expressed or implied. A potential health hazard exists without original equipment replacement.

All warranted items become the sole property of Minuteman or its original manufacturer, whichever the case may be.

Minuteman disclaims any implied warranty, including the warranty of merchantability and the warranty of fitness for a particular purpose. Minuteman assumes no responsibility for any special, incidental or consequential damages.

This limited warranty is applicable only in the U.S.A. and Canada, and is extended only to the original user/purchaser of this product. Customers outside the U.S.A. and Canada should contact their local distributor for export warranty policies. Minuteman is not responsible for costs or repairs performed by persons other than those specifically authorized by Minuteman. This warranty does not apply to damage from transportation, alterations by unauthorized persons, misuse or abuse of the equipment, use of non-compatible chemicals, or damage to property, or loss of income due to malfunctions of the product.

If a difficulty develops with this machine, you should contact the dealer from whom it was purchased.

This warranty gives you specific legal rights, and you may have other rights which vary from state to state. Some states do not allow the exclusion or limitation of special, incidental or consequential damages, or limitations on how long an implied warranty lasts, so the above exclusions and limitations may not apply to you.

Model	Parts	Labor	Poly	Travel**
Cord Electric Group	5yrs	3yrs	12yrs	90 days
Battery Auto Scrubbers (incl. on board charger)	5yrs	3yrs	12yrs	90 days
Battery and Manual Sweepers	3yrs	3yrs	12yrs	90 days

Exceptions.....

Model	Parts	Labor	Poly	Travel**
Port A Scrub, all models (incl. on board charger)	1yr	6months	12yrs	90 days
A3S Blower	1yr	1yr	0	0
Phenom Dual Motor Upright Vacuums	2yrs	2yrs	0	0
Explosion Proof Vacuum	1yr	1yr	0	0
Propane Burnisher	1yr	1yr	0	90 days
E14BQP and E14115 scrubber	1yr	1yr	12yrs	90 days
**Travel, 2 hours max				

<i>Stand-alone Battery Chargers:</i>	One year
<i>Replacement Parts:</i>	Ninety days
<i>Batteries:</i>	0-3 months full replacement, 4-12 months pro-rate
<i>Polypropylene Plastic Tanks:</i>	12yr warranty, no additional labor

“Excellence Meets Clean”

**Minuteman is a Full Line Manufacturer of Sweepers and Scrubbers,
for Industrial Facilities.**

14N845 U.S. Route 20, Pingree Grove, IL 60140 USA
Phone (800) 323-9420 - www.minutemanintl.com
A Member of the Hako Group