



Electronic Service Manuals

This electronic document is provided as a service to our customers. We do not create the contents of the information contained in this document. Should you have detailed questions pertaining to the information contained in this document, you may contact Michco, or the manufacturer which provided the original information in this electronic deliverable. Michco's only part in this electronic deliverable was the electronic assembly process. By providing this manual on line we are not guaranteeing parts availability.

You may contact Michco through the following methods:

Phone (517) 484-9312 or (800) 331-3339

2011 N. High St. -- Lansing, Michigan -- 48906

Fax: (517) 484-9836

Email: CustServe@Michco.com

Web site: www.Michco.Com

Parts Web site: www.FloorMachineParts.Com

Order Parts on Line at:

www.FloorMachineParts.Com

Directly to Parts & Service:

By Email: **Shop@Michco.com**

By Fax: (517) 702-2041

By Voice: Use numbers above.

Serving the Cleaning Industry Since 1922

Notice: All copyrighted material remains property of original owners, all trademarks are property of respective owners. Manuals are subject to Manufacturer's reproduction limitations. Originals or reproductions were provided by manufacturers through a request. We make no warranty as to the correctness of information provided in this document and you assume all risk. By placing these manuals on line we are not declaring our corporation to be an manufacturer authorized dealer or provider, please check our web site for authorized manufacturers we represent.

340 Sweeper/Scrubber Battery Model

Model: MC340024

OPERATION

SERVICE

PARTS

CARE

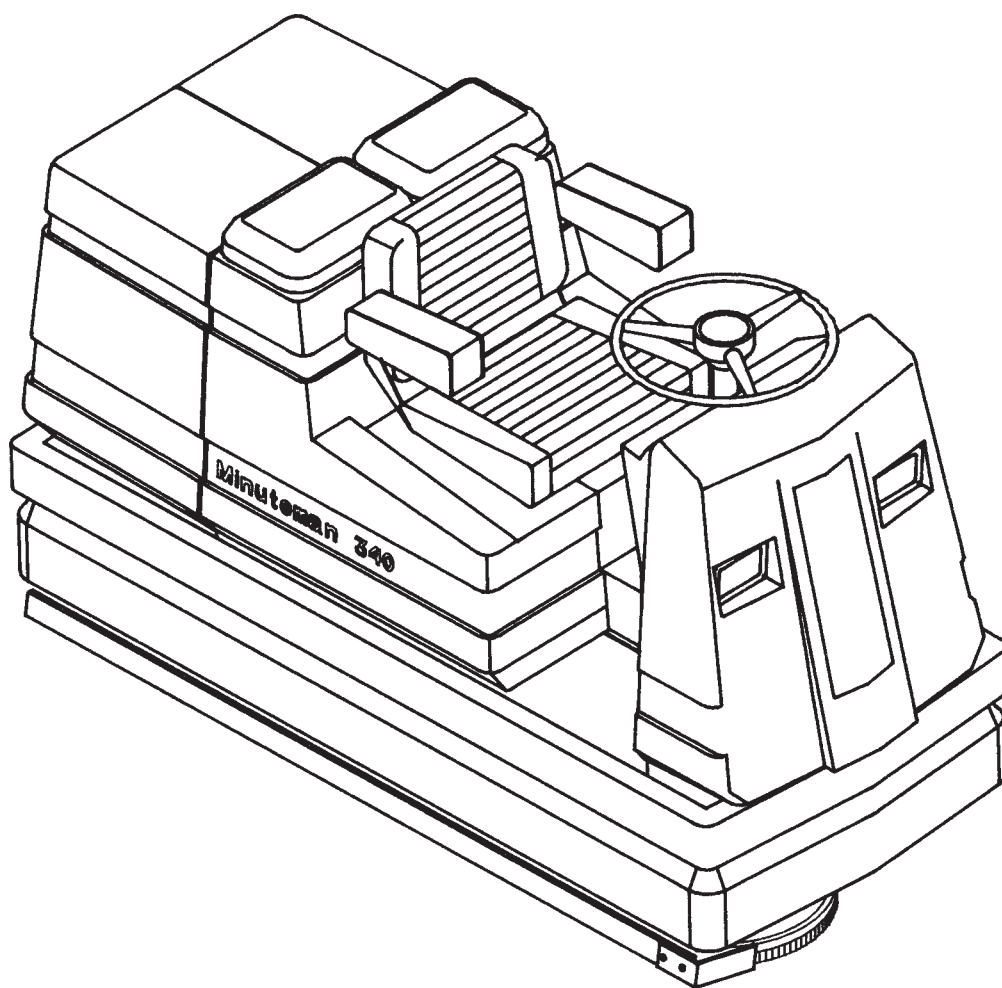

Revised 1/97

Minuteman[®]

OPERATING AND SERVICE MANUAL

INSPECTION

Carefully unpack and inspect your scrubber for shipping damage. Each unit is tested and thoroughly inspected before shipment and any damage is the responsibility of the delivering carrier who should be notified immediately.

ELECTRICAL

This machine is battery operated and is designed to operate on 24 volts D.C.

SPECIAL SAFETY PRECAUTIONS

- 1) Keep hands and feet clear of moving parts while machine is in operation.
- 2) Electrical motors and components can cause an explosion when operated near explosive material or vapors. Do not operate this machine near flammable materials such as solvents, thinners, fuels, grain dusts etc.
- 3) While machine is in operation special attention should be paid to avoiding loose floor tile, electrical cables, telephone connection boxes, door jams, etc.

BATTERIES

Scrubbers are shipped without batteries.

Part No. 956729 12V 570AH 20 Hour Rate 2 Required

We do not recommend mixing AMP hour capacities. Any alternate battery sets can be used if they equal physical size and capacity.

BATTERY SERVICE AND INSTALLATION:

• Warning: Battery acid can cause burns. When working on or around batteries, wear protective clothing and safety glasses. Remove metal jewelry. Do not lay tools or metal objects on top of batteries.

CHARGING OF BATTERIES

Part No. 957718 (24V 50AMP) battery charger is recommended to charge batteries. Charge batteries in a well ventilated area; gases generated while charging batteries are explosive. Always charge batteries away from spark or flame.

Fluid levels should be checked before and after charging and be maintained at the proper level. If scrubber is not used for extended periods of time, batteries should be kept fully charged with a boost charge once a week. Batteries should be charged after each use or when battery condition indicator shows LOW CHARGE.

BATTERY CABLE ROUTING

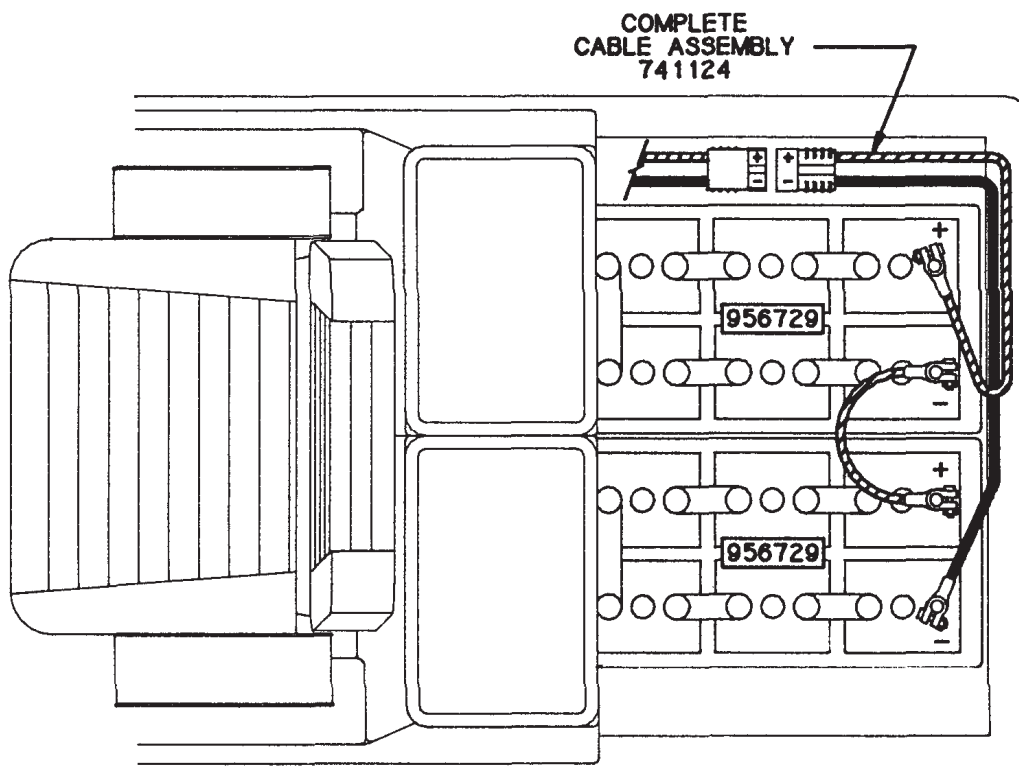

OPERATING PROCEDURES

CAUTION: Familiarity with controlling this machine is essential before entering areas which contain equipment and/or people.

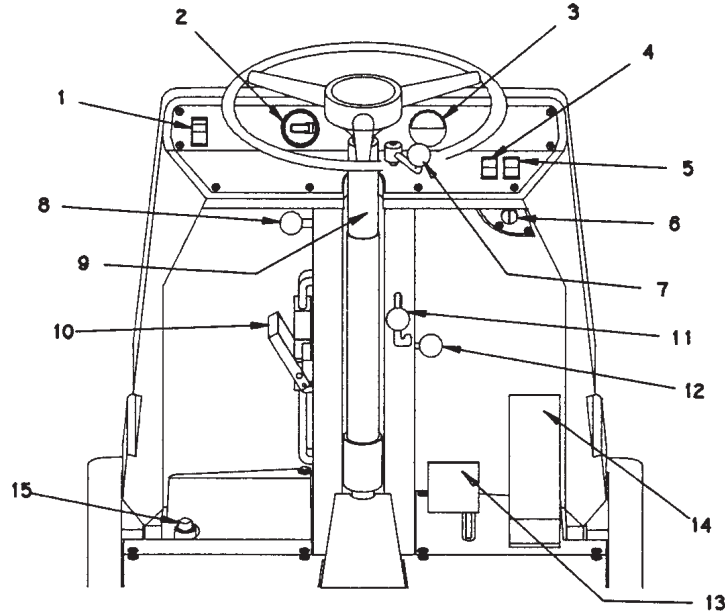

CONTROL/INSTRUMENT	FUNCTION
1. Horn Button	
2. Hourmeter Gauge	Records actual hours of operation.
3. Voltmeter	Indicates when batteries need recharging.
4. Squeegee Control Rocker Switch	Electrically controlled valves permit oil to flow to the squeegee cylinder to automatically lower in forward and raise in reverse. Move switch, second from right on dashboard to down position for automatic control. Move switch to up position for transport and double scrub. The turbine is turned on automatically when the rear squeegee is lowered. The turbine is turned off automatically, after 30 second delay, when squeegee is raised.
5. Brush Control Rocker Switch	Electrically controlled valves permit oil to flow to the brush cylinder to raise and lower the scrub head. Brushes automatically turn when lowered and stop when raised. Move switch on right side of the dashboard to down position to lower the scrub head. Move switch to the up position to raise the scrub head.
6. Key Switch Control	Activates electrical systems.
7. Solution Control	Regulated flow of solution.
8. Tilt Steering	Push in knob, on left side of steering tower, to tilt steering forward or back. Release knob to lock in position.
9. Steering Height Control Collar	Raise collar on steering column to move steering wheel up or down. Lower collar to lock in position.
10. Emergency Battery Disconnect	
11. Side Squeegee Control Knob	This is a manual control to the right of the steering column. Push knob down and to the right to raise front of the side squeegee. Move knob left and up to the lower front of the side squeegee. The rear of the side squeegee works automatically with the rear squeegee.
12. Parking Brake Knob	To set parking brake: while stepping on brake pedal, raise knob located on right side of steering tower, until brake locks. Brake releases automatically when brake pedal is depressed again.
13. Left Pedal	Depress to activate brakes on rear wheels.
14. F & R (Right) Pedal	Activates traction drive control valve. Depress toe for forward and heel for reverse. Pedal travel determines forward and reverse speed.
15. Hydraulic Reservoir Fill Port	Use 10W30 detergent motor oil only.

PRELIMINARY SYSTEMS CHECK

Before starting the unit, make the following inspections:

1. Check charge level of battery. Turn switch key on and observe battery condition gauge. Battery condition and charge level are best determined by checking specific gravity with a hydrometer. Check fluid level in each cell and bring to proper level if necessary.
DO NOT OVERFILL.
2. Check level of oil in hydrostatic reserve tank. Maintain level at two inches below top of tank.
USE SAE 10W30 DETERGENT MOTOR OIL.
3. Inspect for evidence of oil leaks.

BRUSH CONDITION

Inspect condition of brushes. Replace brush when bristles are worn to 1/2 inch. Use the proper brushes for most effective scrubbing action.

The following types of brushes are available:

<u>Part Number</u>	<u>Type</u>
430034	Nylon
430108	Pad Driver
430132	Strato Grit
430111	Poly Grit

Inspect rear squeegee rubber for cuts and foreign matter, which may cause streaking. Squeegee rubber must be replaced when worn to a level where they no longer wipe the floor dry. The side squeegee or corner squeegee is used while turning corners and while scrubbing along pallets, cartons, carpets or any condition where it is advisable to immediately direct the water away from the scrubbing edge. Electrically controlled valves permit oil to flow to the squeegee cylinder to automatically lower in forward and raise in reverse. The squeegee switch raises rear squeegees for transport and double scrubbing.

RECOVERY TANK

Drain recovery tank before re-filling solution tank.

WARNING: Recovery tank float switch will shut off turbines when tank is filled to capacity.

Two drains are provided on the recovery tank. For access to the rear drain hose, loosen the two wing bolts under the rear skirt and remove skirt. Direct hose to drain and remove plug end of hose.

CAUTION: When replacing hose in holder, ensure that it does not interfere with squeegee linkages.

To clean sludge from bottom of tank, remove lower left side panel and open gate valve at bottom of tank. Flush tank with water.

PREPARE TO SCRUB

1. Fill solution tank with clean water. It is recommended that cleaning chemicals be added to tank while being filled to insure an even mixture. Warm water is recommended, but not essential. Use a low foaming chemical.
2. Sit on operator's seat. Turn on ignition switch.
3. Use appropriate switches to place brushes and squeegees in up position.
4. Depress foot pedal and proceed to area to be scrubbed.
5. Lower brushes with brush control switch.
6. Open solution valve.
7. Depress foot pedal to appropriate speed for the conditions:
 - A. Heavy soil: Slow ground speed
 - B. Light soil: Faster ground speed
8. Adjust solution control valve to allow only enough solution to the scrub path. **DO NOT** allow excessive solution to flood scrub path.
9. Lower squeegees with squeegee control switch. Turbines start automatically when squeegees are lowered and stop when raised. Squeegees raise automatically when machine is reversed.
10. To operate side squeegee, release knob to the right of steering column. This lowers the front of the side squeegee. The rear operates automatically. To raise side squeegee, return knob to original position. The side squeegee should be used to eliminate water left on the floor while turning and when scrubbing close to carpeting, cartons or close to walls. A 90 degree turn in a corner can be scrubbed and dried with side and rear squeegee down. **DO NOT** use side squeegee except when necessary. Avoid making right hand turns with side squeegee down.

SCRUBBING PROCEDURE

1. Maintenance Scrub (single pass).
 - a. Move brush control to down position.
 - b. Move squeegee control switch to down position.
 - c. Open solution control level and adjust to proper flow.
 - d. Slowly depress right foot pedal to desired ground speed.
 - e. Use side squeegee while turning to eliminate leaving water on turns.
 - f. Single pass procedure should be used where a heavy soil build-up does not exist.
2. Multiple Scrub (heavy soil).
 - a. Move brush control switch to down position.
 - b. Open solution control lever and adjust to proper flow.
 - c. Slowly depress right foot pedal to desired ground speed. A slow ground speed is most desirable in cleaning heavy soil build-up.
 - d. Continue to dispense solution while scrubbing until all soilage can be suspended in solution. Move squeegee control switch down. Scrub entire area a second time while drying the surface with squeegees and turbines operating. **NOTE:** In extreme conditions, the area may need to be scrubbed several times until clean or until solution on the floor becomes saturated with soil.
 - e. Check solution level in tank while closest to water source.
 - f. Recovery tank must always be emptied and cleaned at time of refilling solution tank. Squeegees will stop picking up solution when recovery tank is full.

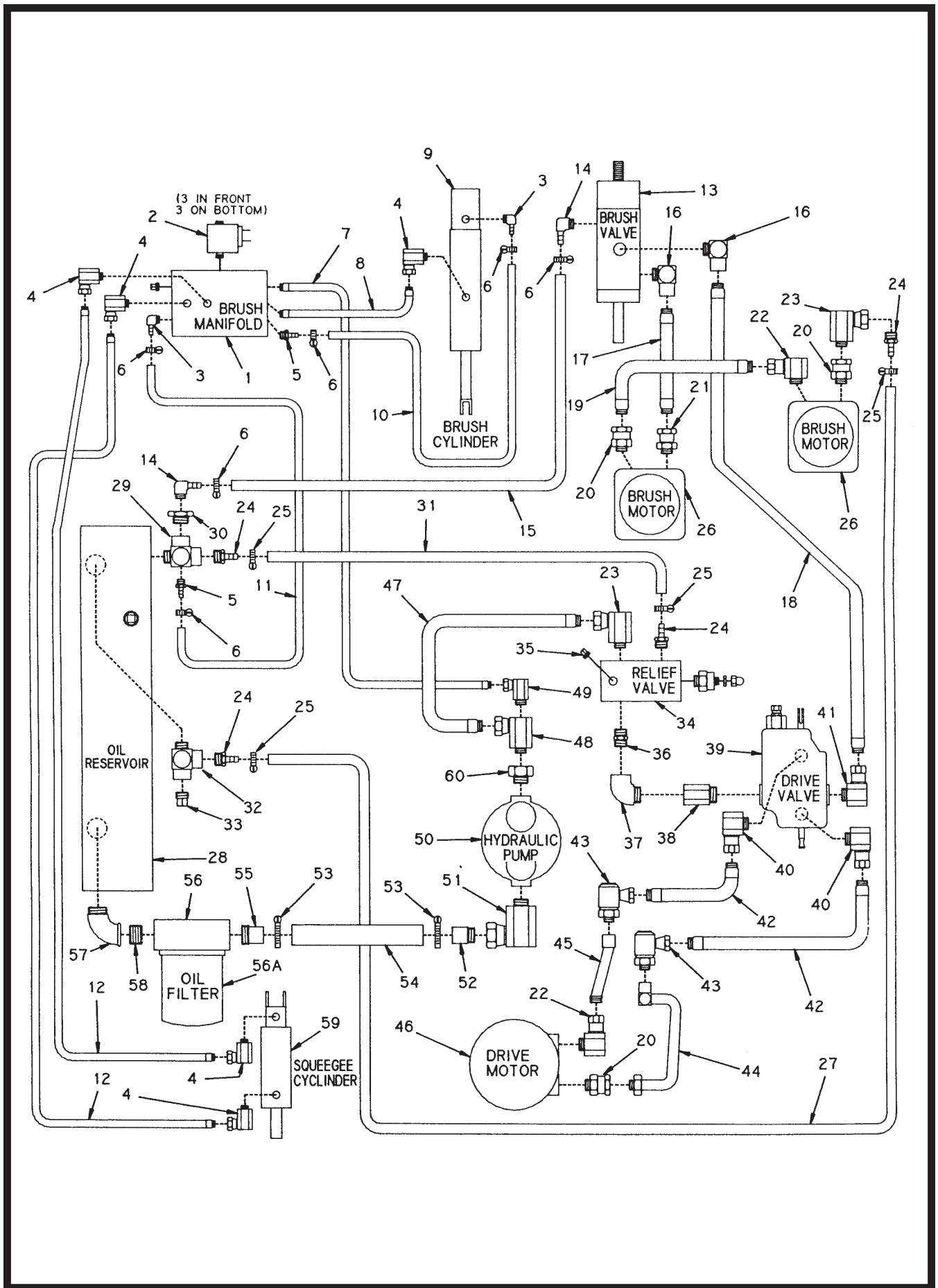

Parts List

ITEM	PART NO	QTY	DESCRIPTION
1	340599	1	Manifold, Brush
2	340539	1	Cartridge Solenoid Valve
3	340536		Ell
4	340524		Ell, Swivel
5	340484		Fitting
6	340506	4	Clamp
7	340534	1	Hose
8	340535		Hose
9	340555	1	Cylinder
10	340541	1	Hose
11	340542	1	Hose
12	340531	2	Hose
13	340570		Valve, Brush
14	340538		Ell
15	340543	1	Hose
16	340530	2	Street Ell
17	340533		Hose
18	340520	1	Hose, 31 inch
19	340521		Hose
20	340537		Fitting
21	340548		Fitting
22	340517		Fitting
23	340516		Ell, Swivel
24	340523		Coupling
25	340463	4	Clamp
26	340505		Motor, Brush
27	340549	1	Hose
28	340564	1	Reservoir, Oil
29	340600		Fitting
30	340486		Bushing
31	340544	11	Hose
32	340515		Tee
33	340476		Plug
34	340550		Cartridge, Relief Valve
35	340492		Plug
36	340622		Pipe Nipple
37	340513		Ell, Street
38	340518		Adaptor
39	340545		Drive Valve
40	340547		Fitting
41	340546		Fitting
42	340532		Hose
43	340519		Fitting
44	340590		Line, Hydraulic
45	340589		Line, Hydraulic
46	340502	1	Motor, Wheel
47	340522	1	Hose
48	340566		Ell, Swivel
49	340593		Valve, Check
50	340528	1	Pump
51	340527		Fitting
52	340603		Pipe
53	340495	2	Clamp
54	340540	1	Hose
55	340526		Fitting
56	340465	1	Filter Assembly
57	340467		Ell, Street
58	340478		Nipple
59	340558	1	Cylinder
60	340525		Adaptor

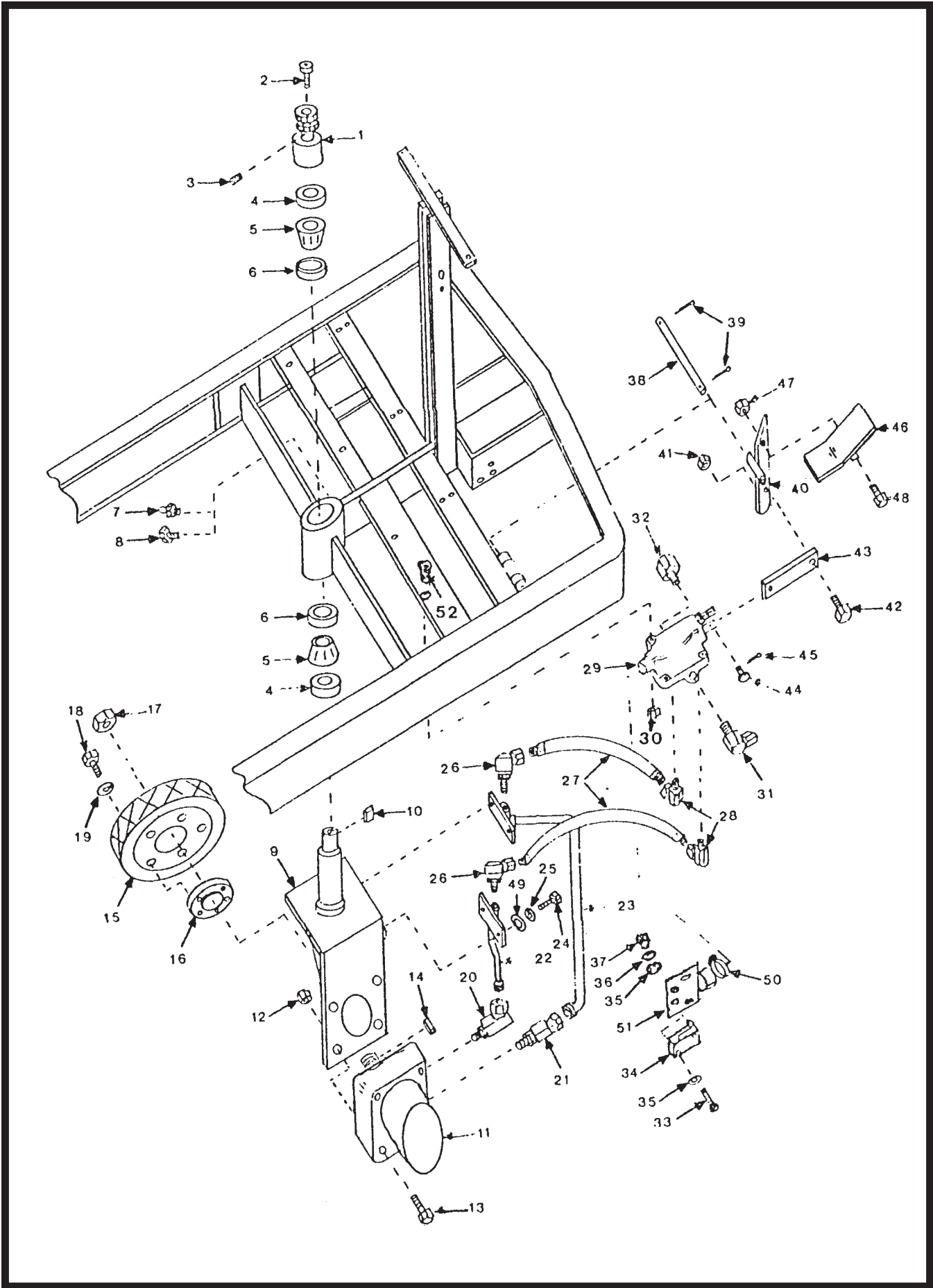

Parts List

ITEM	PART NO	QTY	DESCRIPTION
1	340556	1	Adaptor, Steering
2	710987	1	SCR-SC 3/8-16 x 1.50 STPL
3	710822	2	SCR-SC 1/4-20 x .37 ST NI
4	340488	2	Seal
5	340490	2	Cone
6	340491	1	Cup
7	340496	1	Fitting, Grease
8	710751	1	1/4 28 x 1/2 HH BLT
9	340416	1	Fork, Steering
10	340554	1	Key
11	340502	1	Motor, Wheel
12	711376	4	Nut-Nyloc 1/2-13
13	710754	4	1/2 x 13 x 2 3/4 Hardene
15	340561	1	Wheel, Drive
16	340489	1	Hub, Wheel
18	712037	5	7/16 x 20 1/4 BLT
19	712035	5	7/16 Lockwasher
20	340517	1	Fitting
21	340527	1	Fitting
22	340589	1	Line, Hydraulic
23	340590	1	Line, Hydraulic
24	711202	4	BLT-HH 1/4-20 x .50 STPL
25	711544	4	WSR-Helical 1/4
26	340519	2	Fitting
27	340532	2	Hose
28	340547	2	Fitting
29	340545	1	Drive Valve
30	711373	2	Nut-Nyloc 1/4-20
31	340546	1	Fitting
32	340518	1	Adaptor
33	710490	4	SCR-MC 4-40 x .50 STPL
34	741116	2	Micro Switch
35	711531	8	WSR-Finish #6
36	711596	4	WSR-Internal Lock #4
37	711428	4	Nut-Hex 4-40
38	340421	1	Pin, Pedal
39	711809	2	1/8 x 1 Cotter Pin
40	340419	1	Arm, Forward/Reverse
41	711375	1	Nut-Nyloc 3/8-16
42	711242	1	BLT-HH 3/8-16 x 1.00
43	340420	1	Link, Forward/Reverse
44	712097	1	Clevis Pin
45	711805	1	Cotter Pin .08 x 1.00
46	340445	1	Pedal, Forward/Reverse
47	711374	1	Nut-Nyloc 5/16-18
48	711230	1	BLT-HH 5/16-18 x 1.00 STPL
49	711505	4	WSR-Flat 1/4
50	340495	1	Clamp
51	340595	1	Bracket, Switch
52	710587	2	SCR-MC 1/4-20 x 1.50 ST NI

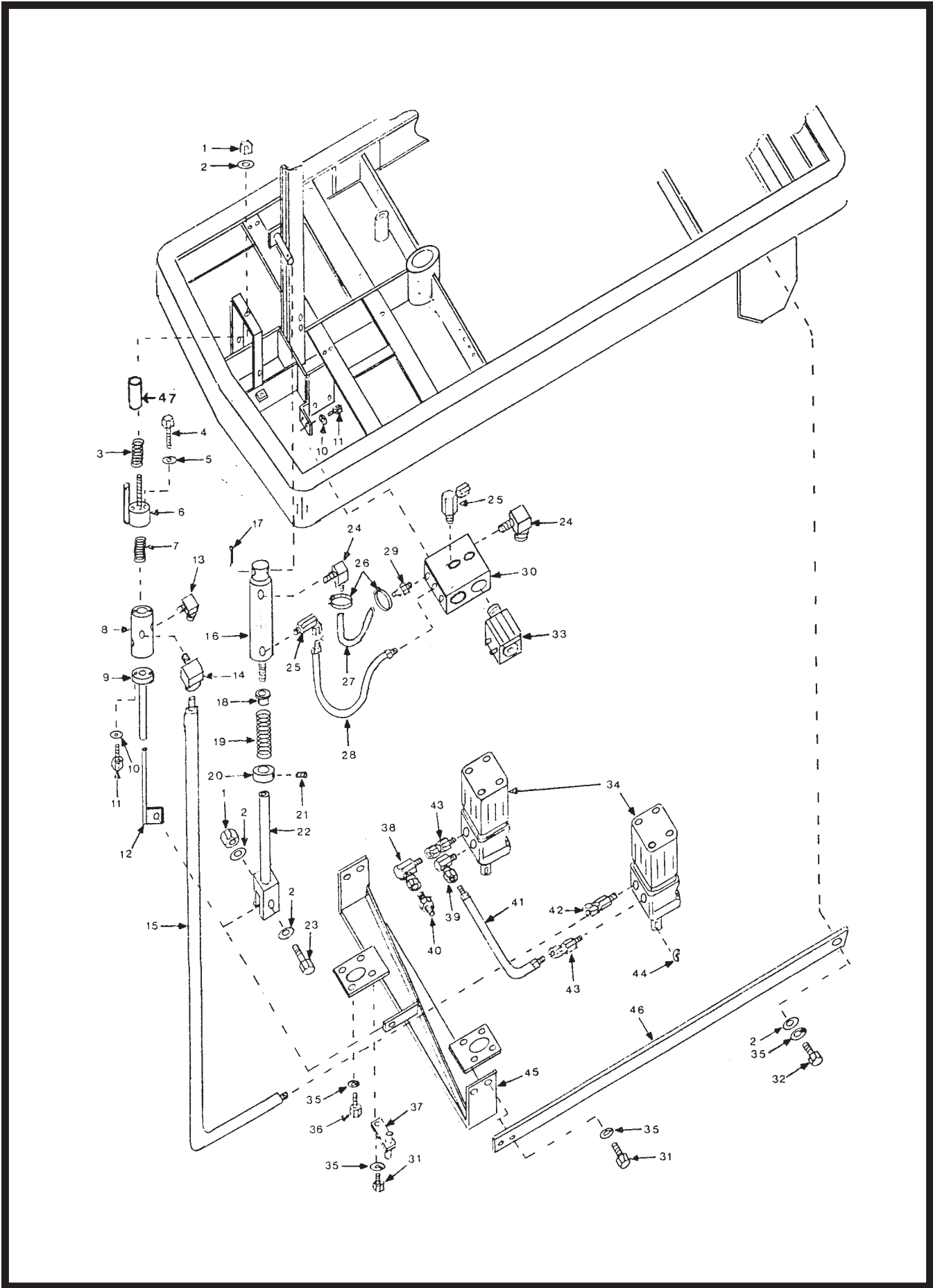

Parts List

ITEM	PART NO	QTY	DESCRIPTION
1	711375	2	Nut-Nyloc 3/8-16
2	711508	5	WSR-Flat .44 x 1.00 x .06
3	340576	1	Spring
4	711214	2	BLT-HH 1/4-20 x 2.00 STPL
5	711544	1	WSR-Helical 1/4
6	340586	1	Cap, Top
7	340503	1	Spring
8	340570	1	Valve, Brush
9	340571	1	Extension, Valve
10	711544	2	WSR-Helical 1/4
11	711207	4	BLT-HH 1/4-20 x 1.00 STPL
12	340429	1	Actuator, Valve
13	340538	1	Ell
14	340530	2	Street Ell
15	340533	1	Hose
16	340555	1	Cylinder
17	711807	1	Cotter Pin .12 x 1.75
18	340501	1	Bushing
19	340475	1	Spring, Brush
20	340480	1	Collar
21	711024	1	SCR-SK 5/16-18 x .50
22	340400	1	Rod, Brush Lift
23	711243	1	BLT-HH 3/8-16 x 1.5 ST PL
24	340536	2	Ell
25	340524	2	Ell, Swivel
26	340506	2	Clamp
27	340514	1	Nipple
28	340535	1	Hose
29	340624	1	Hose Barb Adapter
30	340599	2	Manifold, Brush
31	711242	6	BLT-HH 3/8-16 x 1.00
32	711241	2	BLT-HH 3/8-16 x .75
33	340539	6	Cartridge Solenoid Valve
33A	741115	6	Coil Solenoid Valve
34	340505	1	Motor, Brush
35	711546	14	WSR-Helical 3/8
36	711246	6	BLT-HH 3/8-16 x .87 ST PL
37	340427	2	Outlet, Solution
38	340516	1	Ell, Swivel
39	340517	1	Fitting
40	340523	1	Coupling
41	340521	1	Hose
42	340548	1	Fitting
43	340537	2	Fitting
44	340623	2	Woodruff Key Special
45	340426	1	Frame, Brush
46	340428	2	Arm, Brush, Lift
47	340602	1	Hose
48	340019	2	Brush Spindle Adapter
49	340631	2	Key 1/4 x 1/4 x 1.375
50	430035	2	Drive Hub

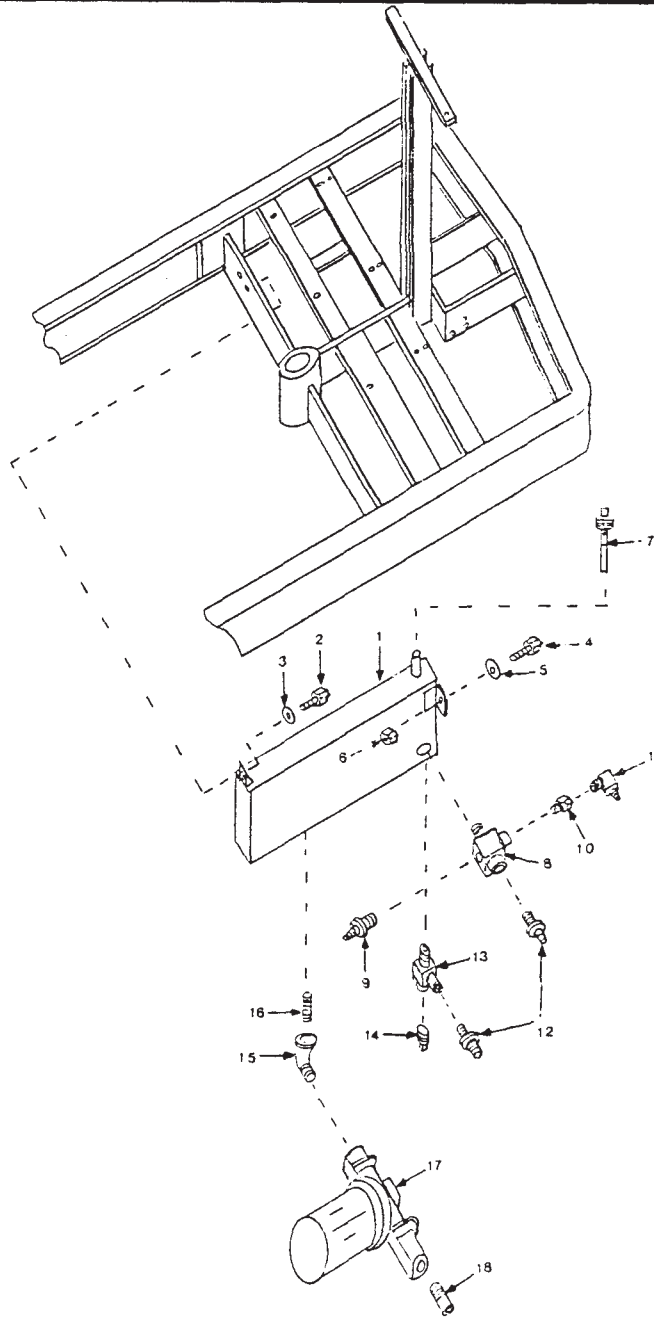

Parts List

ITEM	PART #	QTY	DESCRIPTION	ITEM	PART #	QTY	DESCRIPTION
1	340564	1	Reservoir, Oil	11	340538	1	Ell
2	711241	2	BLT-HH 3/8-16 x .75 STPL	12	340523	2	Coupling
3	711546	2	WSR-Helical 3/8	13	340515	1	Tee
4	711231	1	BLT-HH 5/16-18 x 1.25	14	340476	1	Plug
5	711506	1	WSR-Flat 5/16 ST PI	15	340467	1	Ell, Street
6	711374	1	Nut-Nyloc 5/16-18	16	340478	1	Nipple
7	340565	1	Dipstick	17	340465	1	Filter Assembly
8	340600	1	Fitting	17A	340621	1	Oil Filter
9	340484	1	Fitting				Replacement
10	340486	1	Bushing	18	340526	1	Fitting

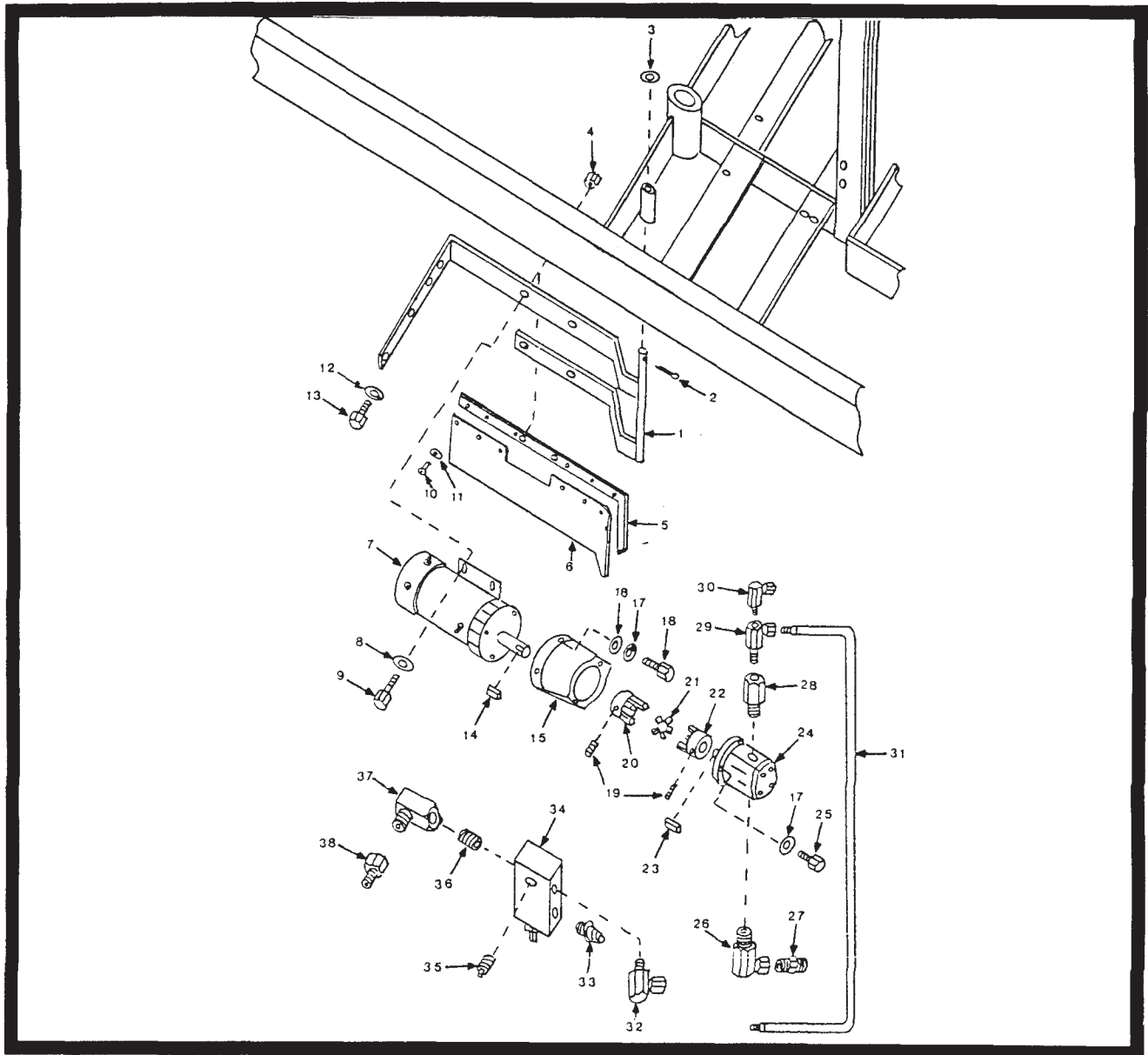

Parts List

ITEM	PART NO	QTY	DESCRIPTION	ITEM	PART NO	QTY	DESCRIPTION
1	340423	1	Mount, Motor	21	340469	1	Insert, Coupling
2	711644	1	3/16 x 1 1/2 Rollpin	22	340470	1	Coupling
3	340424	1	Washer	23	340625	1	Key Hydraulic Pump
4	711374	4	Nut-Nyloc 5/16-18	24	340528	1	Pump
5	340422	1	Strip, Back-up	25	711250	2	BLT-HH 3/8-16 x 1.25 STPL
6	340567	1	Guard, Motor	26	340527	1	Fitting
7	741114	1	Electric Motor 24V	27	340603	1	Pipe
8	711506	4	WSR-Flat 5/16 ST PL	28	340525	1	Adaptor
9	711231	4	BLT-HH 5/16-18 x 1.25	29	340566	1	Ell, Swivel
10	827666	7	Rivet Pop	30	340593	1	Valve, Check
11	711501	7	WSR-Flat #6	31	340522	1	Hose
12	711544	1	WSR-Helical 1/4	32	340516	1	Ell, Swivel
13	711207	1	BLT-HH 1/4-20 x 1.00 STPL	33	340523	1	Coupling
14	340401	4	Key	34	340550	1	Cartridge, Relief Valve
15	340472	6	Hub, Motor	34A	340606	1	Block, Relief
16	711508	6	WSR-Flat .44 x 1.00 x .06	35	340492	1	Plug
17	711546	2	WSR-Helical 3/8	36	340622	1	Pipe Nipple
18	711242	1	BLT-HH 3/8-16 x 1.00 STPL	37	340513	1	Ell, Street
19	711004	1	SCR-SK 1/4-20 x .25	38	340518	1	Adaptor

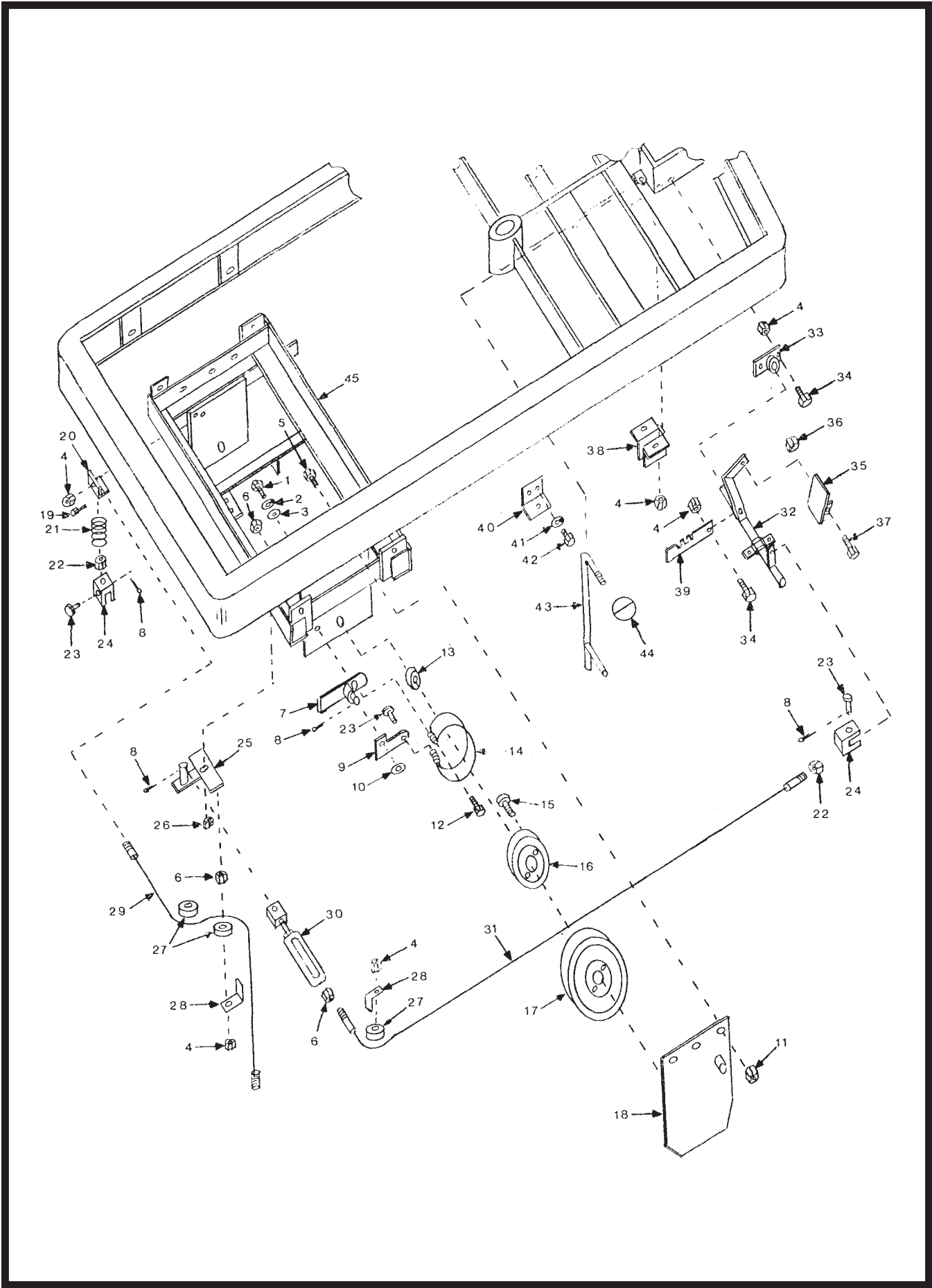

Parts List

ITEM	PART NO	QTY	DESCRIPTION
1	711241	2	BLT-HH 3/8-16 x .75 STPL
2	711546	2	WSR-Helical 3/8
3	711576	2	WSR-Flat .38 x 1.12 x .06
4	711375	4	Nut-Nyloc 3/8-16
5	712037	6	7/16 x 20 1 1/4 BLT
6	711328	5	Nut-Hex 3/8-16 ST PL
7	340410	2	Lever, Brake
8	711809	6	1/8 x 1 Cotter Pin
9	340626	2	Link Brake
10	711506	2	WSR-Flat 5/16 ST PL
11	712034	6	7/16 x 14 Locknut
12	340560	2	Bolt, Special
13	340409	2	Spacer, Wheel
14	340627	1	Brake Band
15	710987	4	SCR-SC 3/8-16 x 1.50 STPL
16	340628	2	Brake Drum
17	340559	2	Wheel, Rear
18	340408	2	Plate, Wheel, Right
19	711204	2	BLT-HH 1/4-20 x .75 STPL
20	340413	1	Bracket, Spring, Left
21	340412	1	Bracket, Spring, Right
22	340629	2	Return Spring
23	712098	4	Clevis Pin
23	711393	3	Nut-Hex Jam 3/8-24 ST PL
25	712055	3	Clevis Pin
26	712051	1	7/16 x 20 Locknut
27	340553	3	Sheave
28	340403	3	Retainer
29	340588	1	Cable, Brake
30	340573	1	Adjustment, Brake
31	340572	1	Cable, Brake
32	340433	1	Shaft, Brake
33	340435	1	Mount, Brake
34	711242	5	BLT-HH 3/8-16 x 1.00
35	340402	1	Pedal, Brake
36	711374	1	Nut-Nyloc 5/16-18
37	711230	1	BLT-HH 5/16-18 x 1.00 STPL
38	340430	1	Bracket, Brake
39	340431	1	Link, Brake
40	340434	1	Bracket, Brake
41	711544	2	WSR-Helical 3/8
43	340432	1	Rod, Brake
44	340462	1	Knob
45	340405	1	Undercarriage

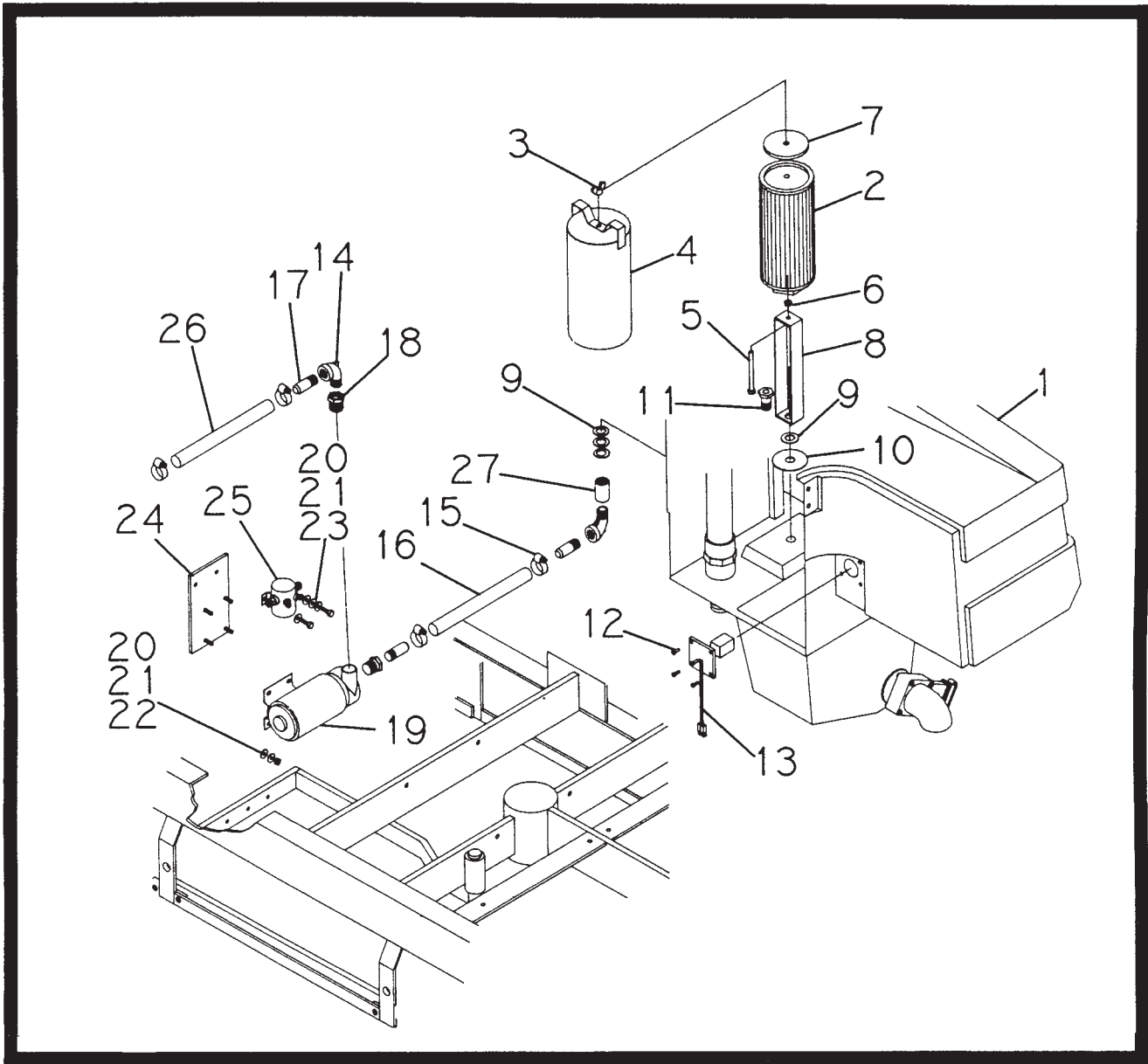

Parts List

ITEM	PART NO	QTY	DESCRIPTION	ITEM	PART NO	QTY	DESCRIPTION
1	340001MCH	1	340 Recycle Recovery Tank	15	340463	4	Clamp
2	340071	1	Filter 340 Recycle	16	340668	1	Hose Recycle Pump
3	711369	1	Nut-Wing 5/16-18	17	340551	3	Pipe
4	340069	1	Cover Recycle Filter	18	340468	2	Bushing
5	807901	1	Bolt	19	340669	1	Pump Recycle
6	712680	1	Nut-Hex 5/16-18	20	711505	7	WSR-Flat 1/4
7	340067	1	Gasket Recycle Filter	21	711544	3	WSR-Helical 1/4
8	340072	1	Bracket Filter Weldment	22	711373	4	Nut-Nloc 1/4-20
9	711517	4	WSR-Flat	23	711204	3	BLT-HH 1/4-20 x .75 STPI
10	340064	1	Gasket Filter Bracket	24	340670	1	Plate Pump Mount
11	828945	1	Bulkhead Fitting	25	741111	1	Solenoid 24V
12	712810	4	SCR-MC 10-24 x .37	26	340665	1	Hose Recycle
13	741110	1	Float Turbine	27	340065	1	Coupling 1/2 NPT
14	57-81-A	2	Fitting 1/2 x 1/2 ELL 90				

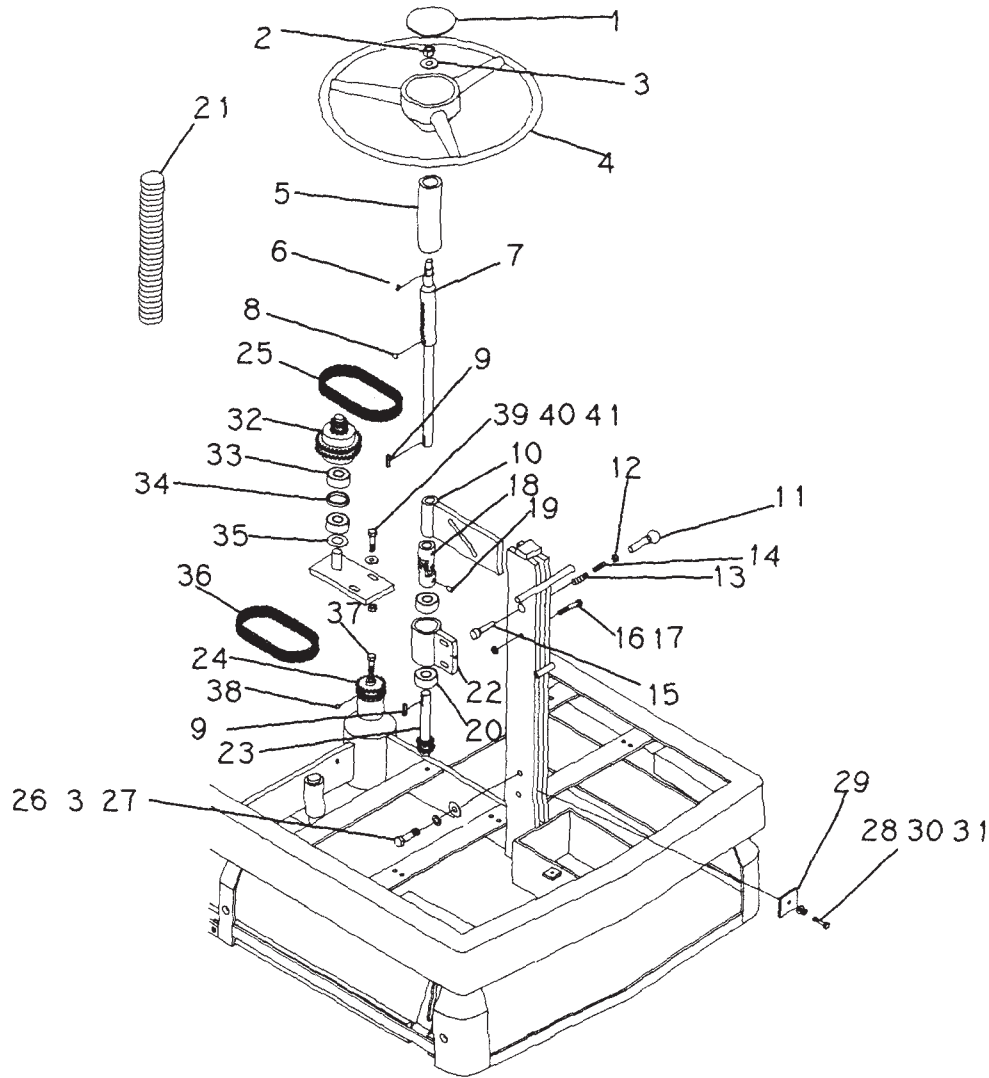

STEERING ASSEMBLY

ITEM	PART NO	QTY	DESCRIPTION	ITEM	PART NO	QTY	DESCRIPTION
1	340477	1	Cap, Steering	21	340594	1	Steering, Cover
2	711337	1	Nut, Hex 1/2-20 ST	22	340557	1	Holder, Bearing
3	711509	1	WSR, Flat 1/2	23	340610	1	Shaft, Steering, Lower
4	340471	1	Wheel, Steering	24	340556	1	Adaptor, Steering
5	340584	1	Cover, Steering	25	340612	1	Chain, Short
6	340499	1	Woodruff Key 1/16 x 5/8	26	712047	2	BLT-HH 1/2-13 x 1.50
7	340563	1	Shaft, Steering, Upper	27	711547	2	WSR-Helical 1/2
8	340504	1	Ball	28	711210	1	BLT-HH 1/4-20 x 1.25
9	340401	2	Key	29	340404	1	Plate
10	340417	1	Slide, Tilt	30	711505	1	WSR-Flat 1/4
11	340583	1	Extension, Knob	31	711544	1	WSR-Helical 1/4
12	711319	1	Nut, Hex 5/16-18 ST	32	340611	1	Idler, Sprocket
13	340494	1	Spring, Park Brake	33	340512	2	Bearing
14	340587	1	Rod, Steering	34	340457	1	Spacer
15	340418	1	Pin, Steering	35	340458	1	Washer
16	711234	1	BLT-HH 5/16-18 x 2.00	36	340613	1	Chain, Long
17	711374	1	Nut, Nyloc 5/16-18	37	710987	1	SCR-SC 3/8-16 x 1.50
18	340562	1	Coupling	38	710822	1	SCR-SC 1/4-20 x .37
19	711004	2	SCR-SK 1/4-20 x .25	39	711234	2	BLT-HH 5/16-18 x 2.00
20	340497	2	Bearing	40	711508	2	WSR-Flat

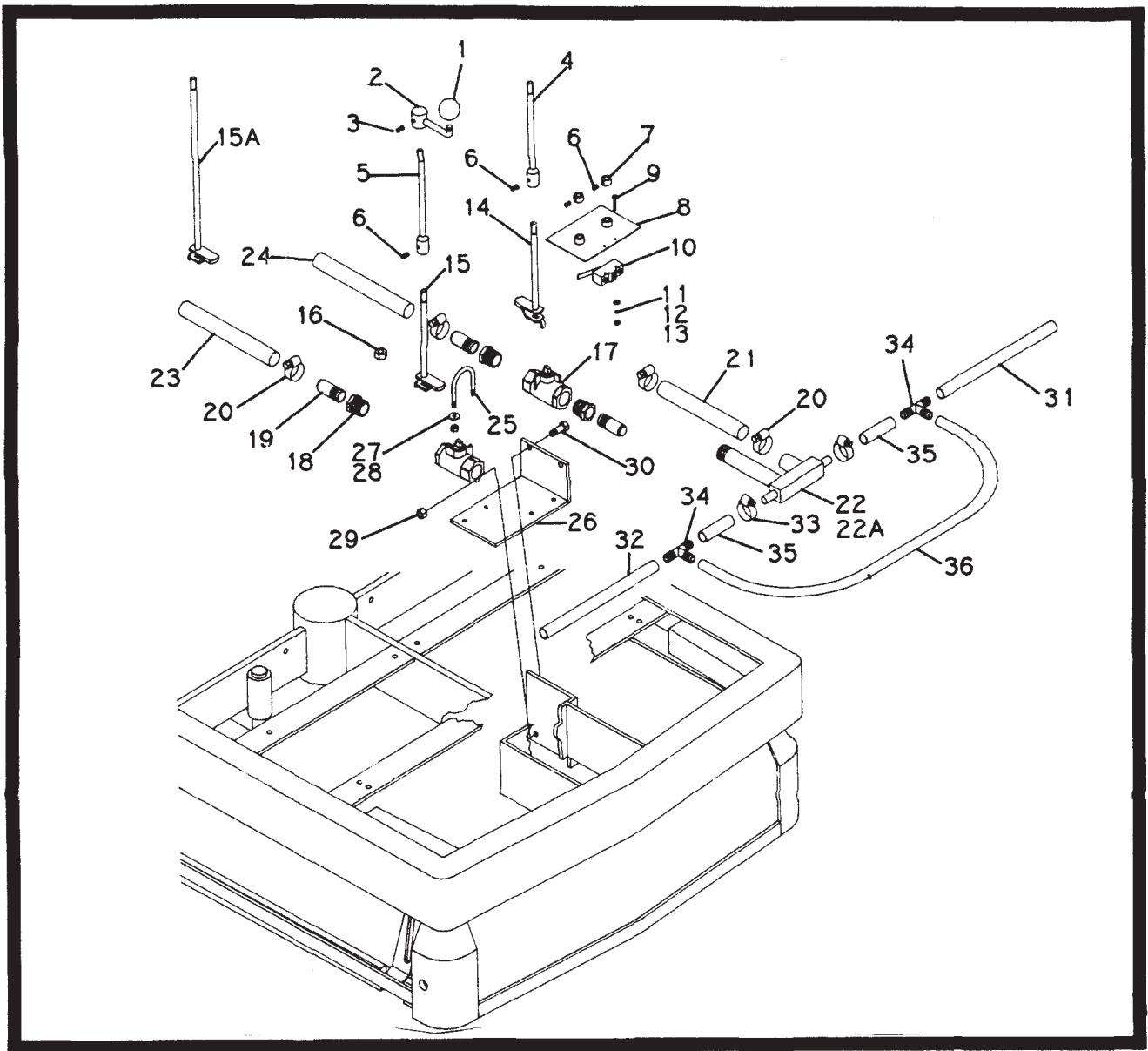

WATER VALVE ASSEMBLY

ITEM	PART NO	QTY	DESCRIPTION	ITEM	PART NO	QTY	DESCRIPTION
1	340552	2	Knob	19	340551	3	Pipe
2	340447	2	Handle	20	340463	2	Clamp
3	710822	2	Set, SCR 1/4-20 x .25	21	340660	1	Hose
4	340655	1	Extension, Recycle	22	340663	1	Distributor, Water
5	340611	1	Extension, Solution	23	340579	1	Hose, Solution
6	711011	4	Set, SCR 1/4-20 x .25	24	340665	1	Hose, Recycle
7	340656	2	Collar	25	340493	2	U-Bolt
8	340657	1	Plate, Micro Switch	26	340666	1	Bracket, Valve
9	710307	2	SCR 6-32 x 1	27	711544	4	1/4 Lock Washer
10	340658	1	Switch	28	711316	4	Nut 1/4-20
11	711501	2	#6 Flat Washer	29	711380	2	Nut-Nyloc 3/8-16
12	711541	2	#6 Lock Washer	30	711242	2	Bolt 3/8-16 x 1
13	711301	2	Nut 6-32	31	340569	1	Hose, Left
14	340659	1	Rod, Recycle	32	340592	1	Hose, Right
15	340662	1	Rod, Solution	33	340506	1	Clamp
16	711446	2	Nut 7/16-20 UNF	34	341249	2	1/2 x 1/2 x 1/2 Hose BARB Tee
17	340473	2	Valve, Water	35	341250	2	1/2 ID Clear Hose 2.5"
18	340468	3	Bushing	36	341251	1	1/2 ID Clear Hose 11.5"

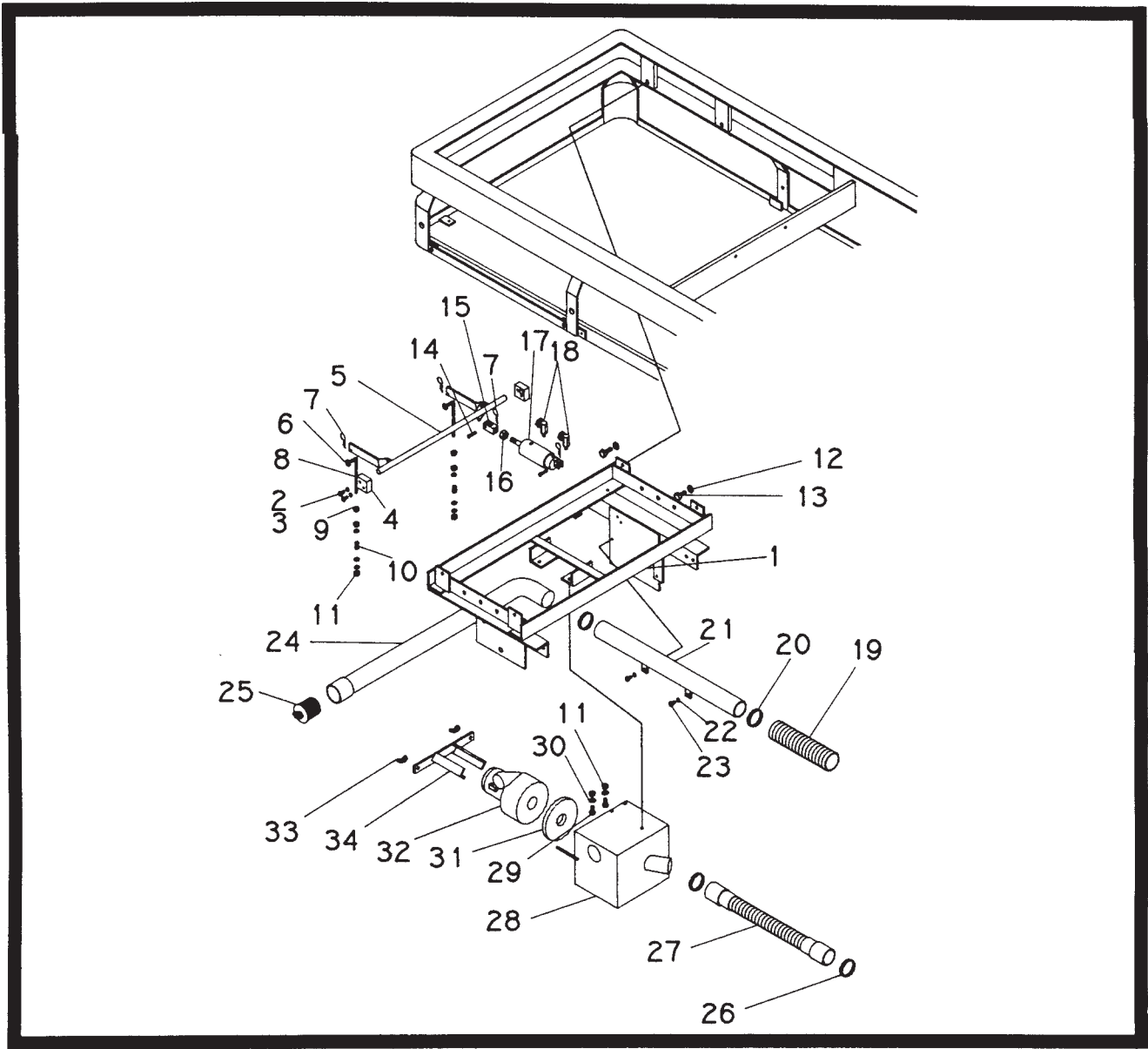

SQUEEGEE LIFT & VACUUM ASSEMBLY

ITEM	PART NO	QTY	DESCRIPTION	ITEM	PART NO	QTY	DESCRIPTION
1	340405	1	Under Carriage	18	340524	2	Swivel Ell
2	711250	4	Bolt 3/8-16 x 1.25	19	340597	1	Hose
3	711546	4	Lock Washer 3/8	20	340464	3	Clamp
4	340406	2	Squeegee Lift Mount	21	340596	1	Drain Tube
5	340448	1	Squeegee Lift	22	711544	2	Lock Washer 1/4
6	711506	8	Flat Washer 5/16	23	711202	2	Bolt 1/4-20 x .50
7	711809	4	Cotter Pin	24	340598	1	Drain Hose
8	340414	2	Lift Rod	25	750402	1	Plug
9	711319	4	Hex Nut 5/16-18	26	340466	2	Clamp
10	340601	2	Spring	27	340580	1	Vacuum Hose
11	711374	5	Lock Nut 5/16-18	28	340615	1	Turbine Enclosure
12	711547	4	Lock Washer 1/2	29	711228	3	Bolt 5/16-18 x .75
13	712010	4	Bolt 1/2-13 x 1.00	30	711506	3	Flat Washer 5/16
14	712098	2	Clevis Pin	31	828995	1	Gasket
15	712055	1	Clevis	32	740225	1	Turbine
16	711393	1	Jam Nut 3/8-24	33	711366	2	Wing Nut 5/16-18
17	340558	1	Squeegee Cylinder	34	340614	1	Turbine Cover

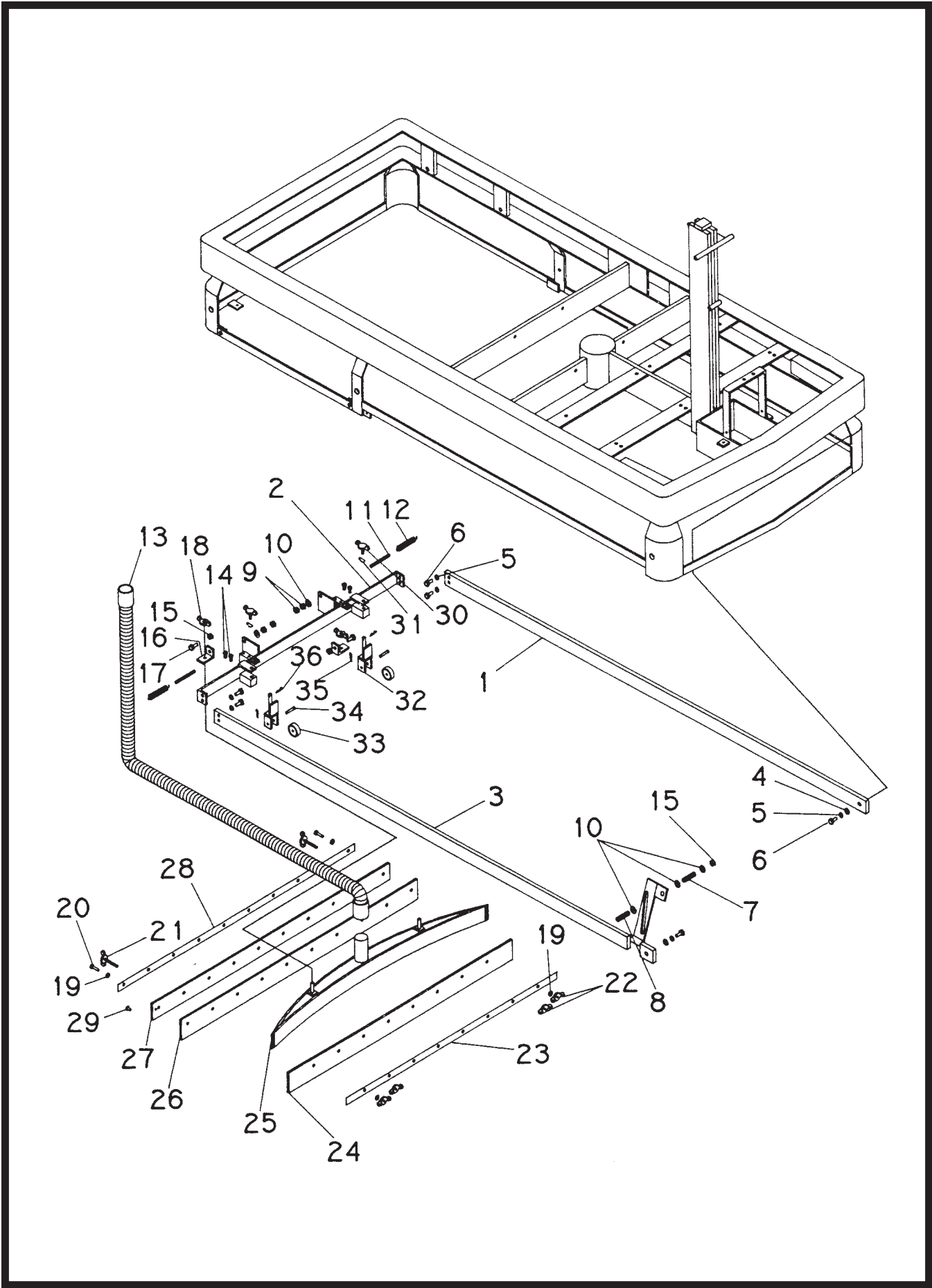

Parts List

ITEM	PART NO	QTY	DESCRIPTION
1	340439	1	Left Squeegee Lift Arm
2	340442	1	Rear Squeegee Lift Arm
3	340440	1	Right Squeegee Arm
4	711506	2	Flat Washer 5/16
5	711545	6	Lock Washer 5/16
6	711228	6	Bolt 5/16-18 x .75
7	340576	1	Spring
8	340578	1	Spring
9	711328	4	Hex Nut 3/8-16
10	711508	5	Flat Washer 3/8
11	340575	2	Adjustment Rod
12	340481	2	Spring
13	450054	1	Hose
14	710599	4	Bolt, Hard 1/4-20 x 1.00
15	711375	3	Lock Nut 3/8-16
16	340441	2	Squeegee Bracket
17	711242	2	Bolt 3/8-16 x 1.00
18	711366	2	Wing Nut 1/4-20
19	711505	4	Flat Washer 1/4-20
20	711207	2	Bolt 1/4-20 x 1.00
21	712001	2	Bolt, Wing 1/4-20 x 2.00
22	711368	4	Wing Nut 1/4-20 (nylon)
23	340460	1	Backup Strip
24	340618	1	Gum Rubber Squeegee
25	340459	1	Rear Squeegee Frame
26	340616	1	Gum Rubber Squeegee
27	340617	1	Neoprene Squeegee
28	340461	1	Backup Strip
29	710180	1	Threaded Screw 1/4-20
30	712002	2	Bolt, Wing 3/8-16 x 1.875
31	340454	2	Spring
32	340450	2	Wheel Mount
33	340511	2	Wheel
34	340630	2	Pin
35	711804	4	Hair Pin Clip
36	809799	2	Hair Pin Clip

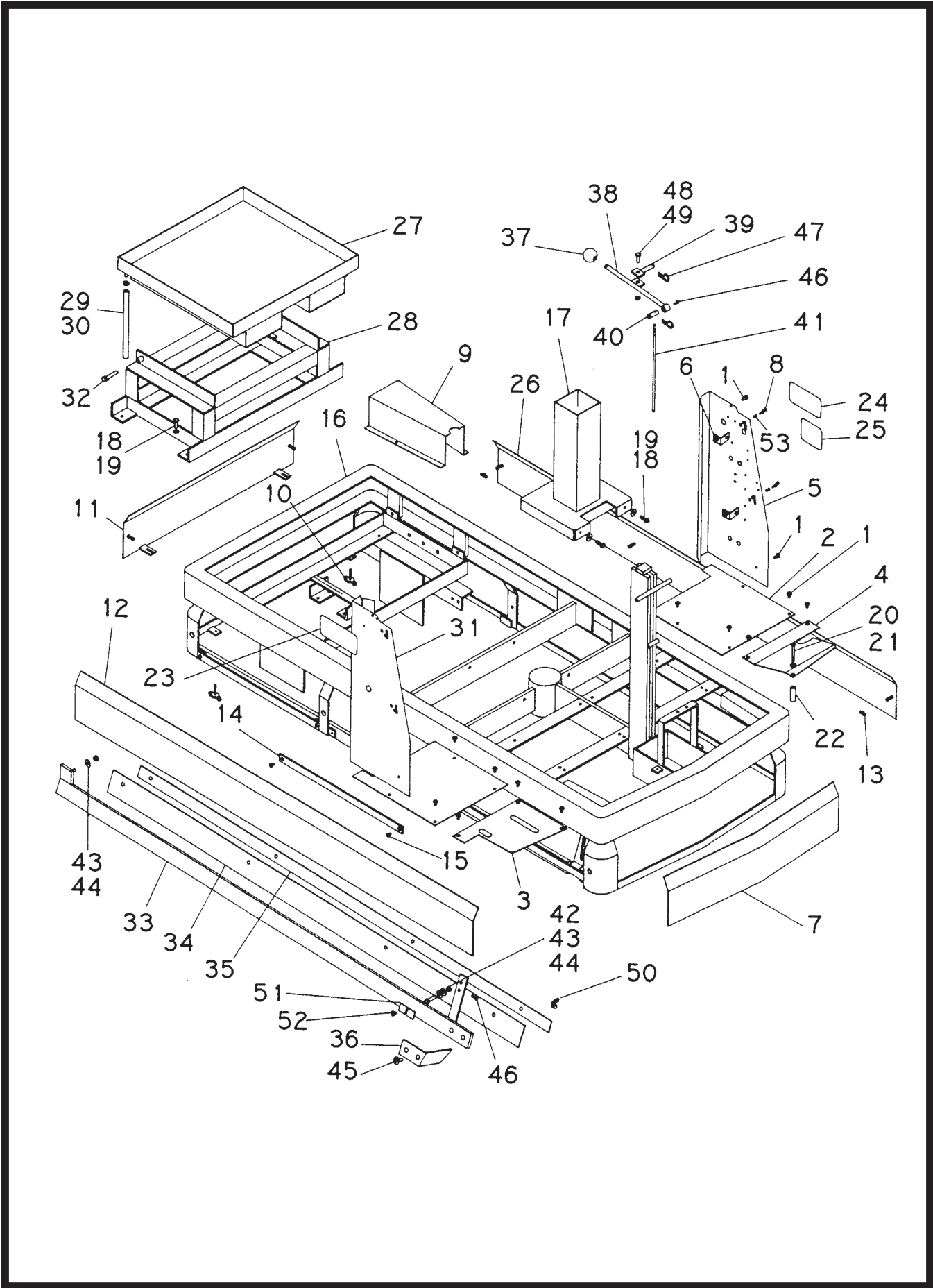

Parts List

ITEM	PART NO	QTY	DESCRIPTION
1	710177	17	SCR-MC 1/4-20 x .37
2	340531	2	Floor, Rear
3	340015	1	RH Floor Panel
4	340014	1	LH Floor Panel
5	340008	1	LH Column Enclosure
6	340010	4	Mounting Bracket
7	340604	1	Front Skirt
8	712101	8	BLT-HH 10-24 x .50
9	340582	1	Chain Cover
10	712055	4	Wing Bolt 1/4 20 x 1 1/4
11	340605	1	Rear Skirt
12	340585	1	Right Side Skirt
13	711366	4	Wing Nut 5/16-18
14	340407	3	Frame Bracket
15	710580	6	1/4 20 x 1/2 FH Socket Set
16	340415	1	Main Frame
17	340022	1	Seat Post Mounting Assembly
18	711230	8	BLT-HH 5/16-18 x 1.00
19	711545	8	Helical WSR 5/16
20	711214	1	BLT-HH 1/4-20 x 2.00
21	711505	1	Flat WSR 1/4
22	809858	1	Spacer
23	715202	1	Side Squeegee Park Adj. Decal
24	715203	1	Tilt/Height Adj. Decal
25	715204	1	Power Disconnect Decal
26	340607	1	Left Side Skirt
27	340031	1	Battery Tray Weldment
28	340049	1	Battery Tray Mount
29	450076	1	Crimp Clamp SS 185R
30	430097	1	Clear Solution Hose 18"
31	340009	1	RH Column Enclosure
32	711247	2	HH Bolt 3/8-16 x 2.00
33	340444	1	Side Squeegee Frame
34	340577	1	Squeegee
35	340443	1	Back-Up Strip
36	340011	1	Side Bar Guard
37	340552	1	Knob
38	340436	1	Side Squeegee Lift
39	340437	1	Side Squeegee Lift Pivot
40	340438	1	Cable Pin
41	340574	1	Side Squeegee Cable
42	711250	1	BLT-HH 3/8 -16 x 1.25
43	711508	3	Flat WSR .44 x 1.00 x .06
44	711375	2	Nyloc Nut 3/8-16
45	710923	2	SCR-SC 5/16-18 x .62
46	710357	2	SCR-MC 10-32 x .75
47	711808	2	Cotter Pin - Hair #3
48	711207	1	BLT-HH 1/4-20 x 1.00
49	712667	1	Nut-Hex 1/4-20 SS Nyloc
50	711367	4	Wing Nut 3/8-16
51	340449	1	Squeegee Adj. Bracket
52	710178	1	SCR-MC 1/4-20 x .50
53	711553	8	#10 Internal Tooth Lock Washer

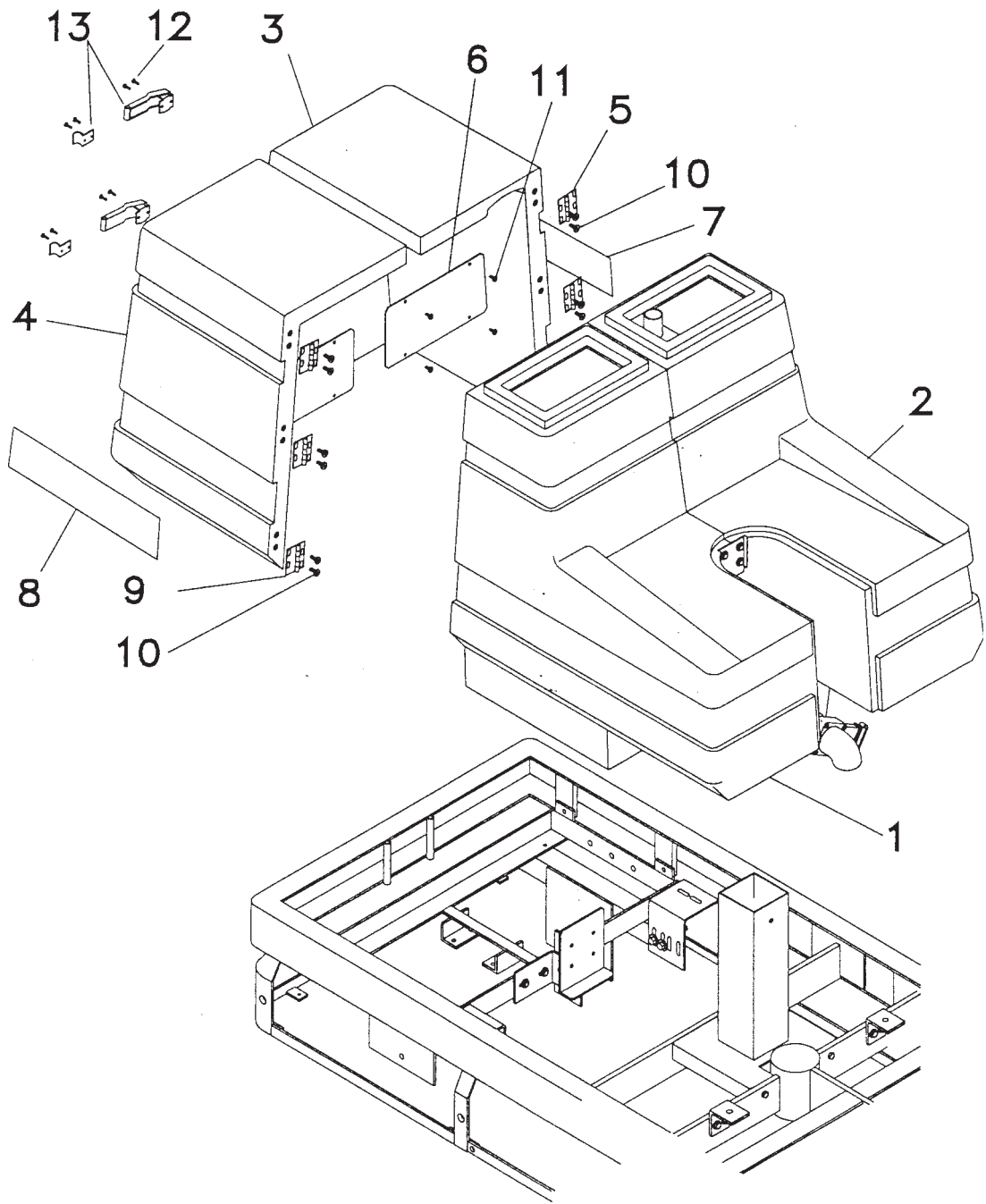

Parts List

ITEM	PART NO	QTY	DESCRIPTION
1	340200	1	Solution Tank Assembly
2	340100	1	Recovery Tank Assembly
3	340003	1	Right Battery Cover
4	340004	1	Left Battery Cover
5	340060	3	Cover Hinge, Right Side
6	340061	2	Rear Vent Screen
7	715210	1	Right Cover Decal
8	715207	1	Left Cover Decal
9	340044	3	Cover Hinge Left Side
10	710177	24	SCR-MC 1/4-20 x .37 ST PL
11	712540	8	SCR-MC 10-24 x .37 SS TH
12	711160	8	#10 HI/LO Screw
13	340664	2	Soft Latch

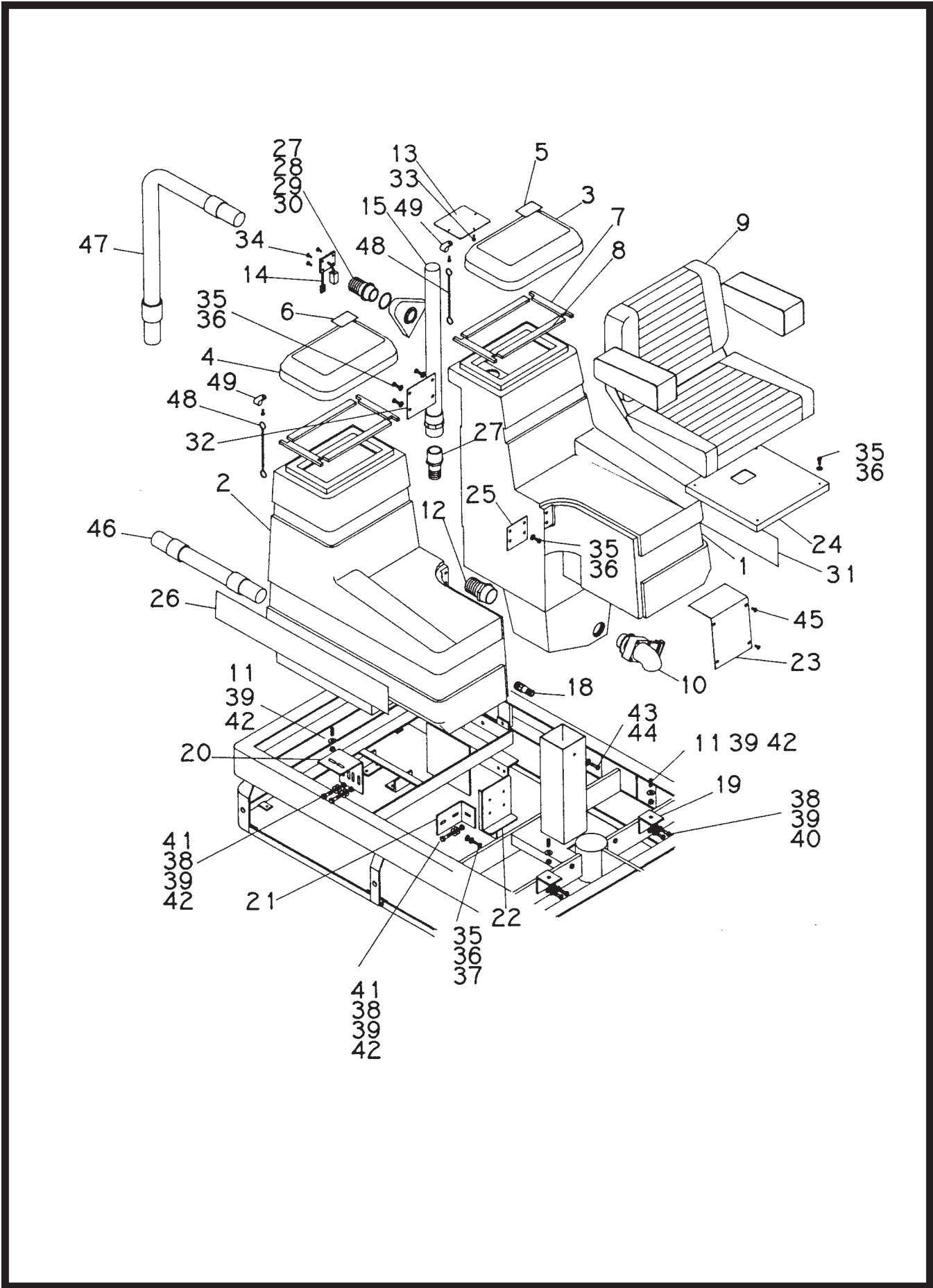

Parts List

ITEM	PART NO	QTY	DESCRIPTION
1	340001	1	Recovery Tank
2	340002	1	Solution Tank
3	340006	1	Recovery Tank Lid
4	340005	1	Solution Tank Lid
5	715206	1	Decal Recovery Tank
6	715205	1	Decal Solution Tank
7	340057	4	Lid Gasket Short
8	340058	4	Lid Gasket Long
9	340498	1	Seat
10	900047	1	2" Waste Gate Valve
11	340045	4	3/8 Stud
12	340046	1	2" Barbed Fitting
13	340017	1	Screen - Tank Lid
14	741110	1	Float Switch
15	340055	1	Vacuum Riser Tube
17	829257	1	1.5 Elbow 90° MPT/HB
18	340047	1	.75 Barbed Fitting
19	340619	2	Support - Tank Front
20	340056	2	Tank Support Ancor Rear
21	340018	1	Tank Ancor Bracket Center
22	340050	1	Tank Shelf Bracket
23	340041	1	Tank Pocket Cover
24	340042	1	Seat Mounting Pan
25	340053	1	Tank Match Plate
26	715208	1	Left Decal Minuteman 340
27	831812	1	Adapter 1.5 MPT/HB
28	831664	1	Washer SS 2.12 ID
29	830448	1	Deflector
30	828971	1	Nut 1.5 Pipe Thread
31	715211	1	Right Decal Minuteman 340
32	340054	1	Tank Match Plate Rear
33	828893	5	Pop Rivet
34	712810	4	SCR-MC 10-24 x .37 RH
35	711203	18	BLT-HH 1/4-20 x .62 STPL
36	711544	18	WSR-Helical 1/4
37	711505	2	WSR-Flat 1/4
38	711546	9	WSR-Helical 3/8
39	711508	13	WSR-Flat 3/8
40	711246	4	BLT-HH 3/8-16 x .87 ST PL
41	711242	5	BLT-HH 3/8-16 x 1 STPL
42	711375	9	Nut-Nyloc 3/8-16
43	711229	2	BLT-HH 5/16-18 x .87 STPL
44	711545	2	WSR-Helical 5/16
45	712540	4	SC-MC 10-24 x .37 SS TH
46	340580	1	Hose Assembly Short
47	450054	1	Vac Recovery Hose
48	340482	2	Tank Chain
49	250038	2	Retainer Bag Clip

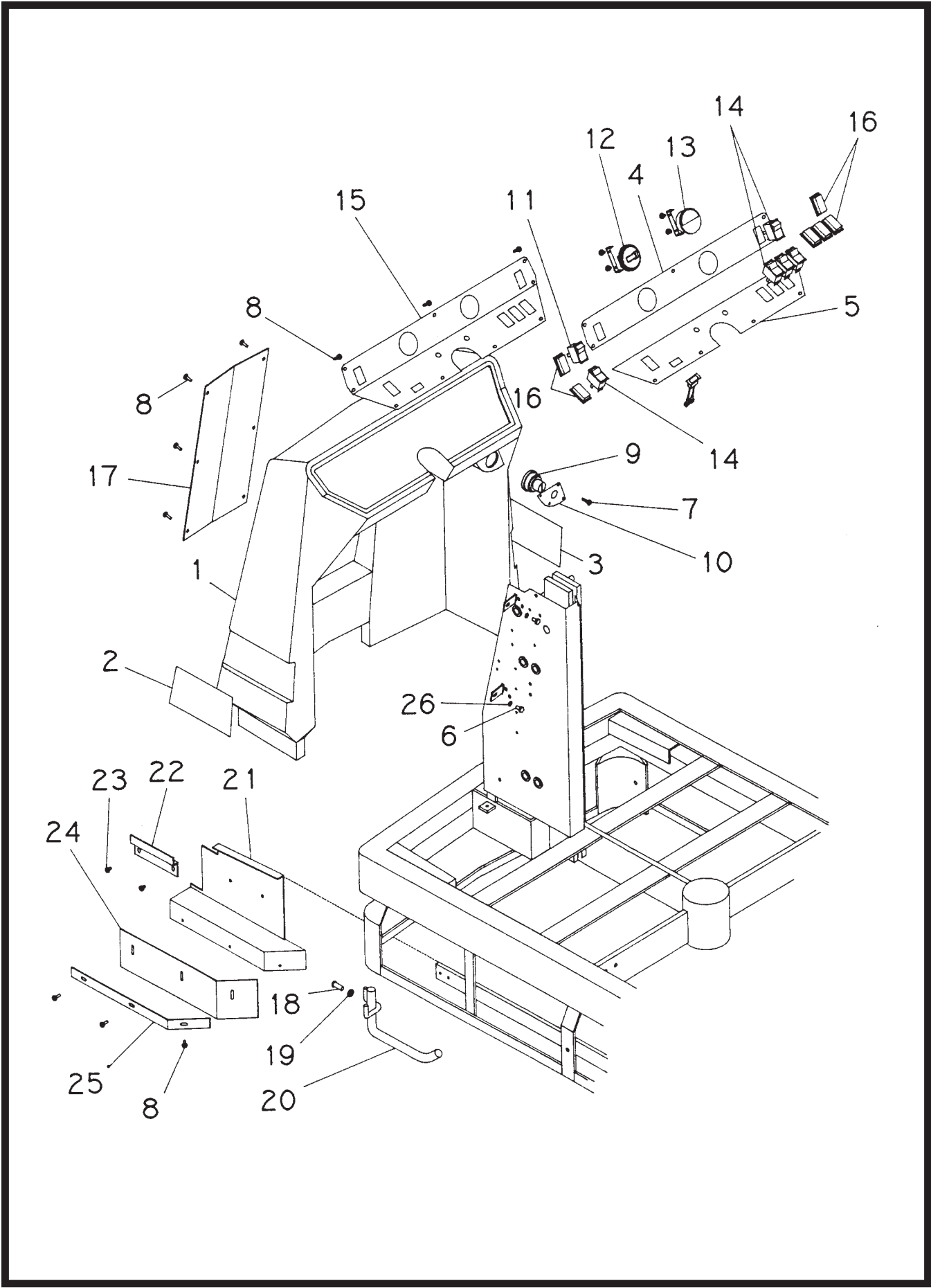

Parts List

ITEM	PART NO	QTY	DESCRIPTION
1	340000	1	Front Shroud/Dash
2	715209	1	Front Left Decal
3	715212	1	Front Right Decal
4	715200	1	Upper Dash Decal
5	715201	1	Lower Dash Decal
6	711202	4	HH Bolt 1/4-20 x .50
7	711161	4	SCR-HI/LO #10 x .75
8	712822	18	SCR-THMS 10-24 x .50
9	741005	1	Key Switch
10	340016	1	Ignition Face Plate
11	740800	1	Switch
12	741007	1	Hour Meter
13	740216	1	Volt Gauge
14	740801	2	Switch
15	340007	1	Rider Dashboard 34B
16	802657	3	Switch Boot
17	340020	1	Front Access Cover
18	710986	1	3/8-16 x 1.00 Allen Head Bolt
19	711546	1	3/8 Lock Washer
20	340653	1	Skid Bar Weldment
21	340080	1	Skirt Assembly Bracket
22	340082	1	Z-Bracket
23	710177	2	SCR-TRHD 1/4-20 x .37
24	340083	1	Splash Skirt
25	340081	1	Skirt Retainer
26	711554	4	1/4 Internal Tooth Lock Washer

SQUEEGEE ADJUSTMENT

The one piece curved squeegee is designed to require a minimum of adjustment. Adjustment may be required to get optimum performance for different floors and conditions.

BASIC ADJUSTMENT:

1. Ensure that scrubber is on a relatively flat surface. Start scrubber and place squeegee switch in down position.
2. Carefully depress the direction control pedal enough to move the vehicle one or two feet forward, allowing the back gum rubber of the rear squeegee to deflect. Adjust nuts (item 1) so that the spring (item 2) is compressed to 1 3/4 inches (44 mm) with the squeegee down.
3. Lower squeegee wheels by turning wing bolts (item 3) until squeegee just touches the floor.

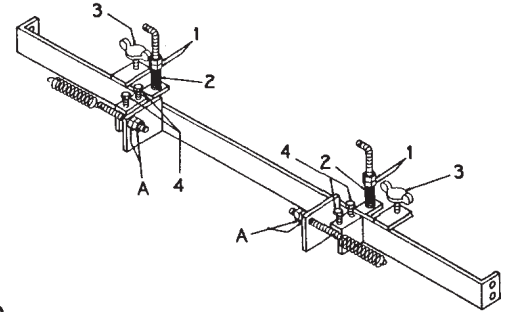

NOTE: Move vehicle forward one to two feet with each adjustment.

4. Adjust the tilt of the squeegee until center and ends are level to the floor, adjust bolts (item 4). **DO NOT** use excessive force, the bolts work in pairs, loosening front bolts and tightening the rear will cause the squeegee ends to raise and center to lower.
5. Once squeegee is level, lower squeegee with adjustment wing bolts (item 3) until 45° deflection is obtained along its entire length.

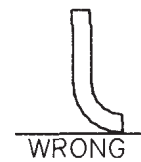
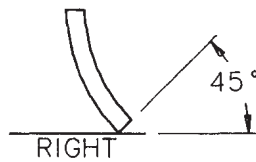
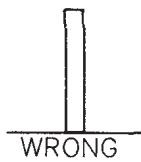

FINE ADJUSTMENT:

6. Check water pickup. If ends or center do not pick up properly, adjust tilt (item 4) to level squeegee. Adjust squeegee wheel height for driest floor (item 3).

For smooth floors, a smaller angle will leave a drier floor, turn wing bolt (item 3) clockwise to raise squeegee.

For rough floors, a larger angle will pull water from holes and cracks better, turn wing bolt (item 3) counter-clockwise to lower squeegee.

BRAKE ADJUSTMENT

This scrubber is equipped with mechanically activated drum type brakes on the rear wheels. A steel cable attached to the foot pedal runs to levers on each brake. Stretching of the cable may occur and adjustment needed.

1. Remove battery cover.
2. Adjust turnbuckle at end of front cable.
IT IS **HIGHLY IMPORTANT** THAT ALL MOVING PARTS OF BRAKE SYSTEM BE KEPT THOROUGHLY LUBRICATED.

STEERING SYSTEM MAINTENANCE AND REPAIR

In general the chain reduction steering system is maintenance free. As in all mechanisms a lubricant should always be present. We recommend a good quality grease such as wheel bearing grease be applied liberally to the chain and sprockets periodically.

REMOVAL AND REPAIR

1. Remove chain guard and right side panel.
2. Remove tension adjusting screw and plate.
3. Remove the two 1/2-13 bolts that secure the steering column to frame.
4. Inspect sprockets for excessive wear. Excessive wear is usually indicated by the sprocket teeth forming very sharp points. If in question replace respective sprockets and chain assembly.
5. Inspect steering column bearings for excessive play, renew if necessary .
6. In the event sprockets are renewed the steering shaft alignment must be adjusted. Install new sprockets and shaft assembly into bearing housing steering column assembly. Do not tighten bearing locking collars at this time.
7. Install steering column assembly to frame using 1/2-13 bolts and tighten lightly. Install tension adjusting screw and plate. Remove excess chain slack. Using a straight edge to ensure that the sprocket teeth are in alignment. Tighten bearing locking collars and set screws.
8. Remove remaining slack in chain. **IMPORTANT: Make sure that the steering shaft is perpendicular to the frame, ensuring equal chain contact on both sprockets.** Tighten 1/2-13 bolts securely. Liberally grease chain assembly.
9. Install chain cover and side cover.

REMOVE AND REPLACE BRUSH DRIVE MOTORS

To remove a brush drive motor, use the following procedure:

1. Remove brush drive assembly.
2. Disconnect hydraulic hose lines at brush motor ports.
3. Remove four cap screws holding brush motor to mounting.
4. Note locations of water outlets.

HYDRAULIC ADJUSTMENTS

Test equipment should include: a high pressure gauge with capabilities of measuring pressure up to 2,500 PSI; pressure gauge with capabilities no less than 150 PSI. Both gauges should also have the ability to thread into a 1/4 NPT female pipe thread. A high pressure hose or pipe adaptor can be used for this purpose.

ADJUST HYDRAULIC PRESSURE TO TRACTION DRIVE MOTORS

Before beginning test procedure, the following items should be acknowledged: account for all oil losses when changing fittings by checking oil reservoir level; all pressure readings must be taken at normal operating temperatures.

1. Remove rear floor.
2. Block front drive wheel such that the motor will stall when high forward pressures are applied. Additional constraints, such as a well constructed wall or immovable object at front frame, would be advantageous.
3. Remove plug from relief valve and install high pressure gauge.

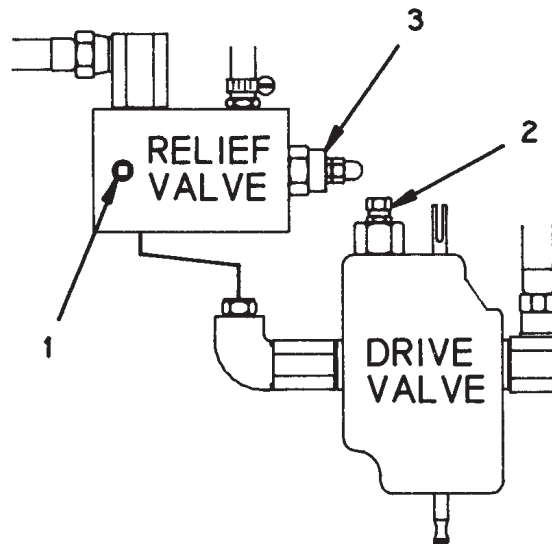

4. Loosen lock nut on pressure adjustment and turn in 1 full turn.
5. Start motor and allow sufficient time for hydraulic system to reach operating temperature.
6. Carefully move direction control pedal to full forward position. Gauge pressure should read 1500 PSI. If not adjust main relief adjustment screw in to increase pressure, out to lower pressure, until correct gauge pressure is obtained. Lock screw in position.
7. While unit is still in full forward, back out the pressure adjustment screw on the drive spool valve body (item 2) slowly until the gauge pressure starts to drop. When a pressure drop is observed turn adjustment screw in only the amount required to return to 1500 PSI. Lock screw in position.
8. Return pedal to neutral, shut off, reinstall protective cover, remove gauge and install pipe plug (wrap plug with teflon tape before installing) in relief valve. Remove constraints.
9. Replace floor panels.

LIMITED WARRANTY

Minuteman International, Inc. warrants to the original purchaser/user that this product is free from defects in workmanship and materials under normal use and service for a period of three years from date of purchase. In addition, Minuteman International, Inc. will, at its option, honor labor warranty claims for the first 12 months from date of sale, provided such claims are submitted through and approved by factory authorized repair stations. Minuteman International, Inc. will, at its option, repair or replace without charge, except for transportation costs, parts that fail under normal use and service when operated and maintained in accordance with the applicable operation and instruction manuals.

This warranty does not apply to normal wear, or to items whose life is dependent on their use and care, such as belts, cords, switches, hoses, rubber parts, electrical motor components or adjustments. Parts not manufactured by Minuteman International, Inc. such as engines, batteries, battery chargers, hydraulic pumps, and tires are covered by and subject to the warranties and/or guarantees of their manufacturers. Please contact Minuteman International, Inc. for procedures in warranty claims against these manufacturers.

Special warning to purchaser — Use of replacement filters and/or prefilters not manufactured by Minuteman International, Inc. or its designated licensees, will void all warranties expressed or implied.

A potential health hazard exists without exact original equipment replacement.

All warranted items become the sole property of Minuteman International, Inc. or its original manufacturer, whichever the case may be.

Minuteman International, Inc. disclaims any implied warranty, including the warranty of merchantability and the warranty of fitness for a particular purpose. Minuteman International, Inc. assumes no responsibility for any special, incidental or consequential damages.

This limited warranty is applicable only in the U.S.A. and Canada, and is extended only to the original user/purchaser of this product. Customers outside the U.S.A. and Canada should contact their local distributor for export warranty policies. Minuteman International, Inc. is not responsible for costs or repairs performed by persons other than those specifically authorized by Minuteman International, Inc. This warranty does not apply to damage from transportation, alterations by unauthorized persons, misuse or abuse of the equipment, use of non-compatible chemicals, or damage to property, or loss of income due to malfunctions of the product.

If a difficulty develops with this machine, you should contact the dealer from whom it was purchased.

This warranty gives you specific legal rights, and you may have other rights which vary from state to state. Some states do not allow the exclusion or limitation of special, incidental or consequential damages, or limitations on how long an implied warranty lasts, so the above exclusions and limitations may not apply to you.

Minuteman[®]

World Headquarters
Minuteman International, Inc.
111 South Rohlwing Road
Addison, Illinois 60101

Minuteman Canada, Inc.
2210 Drew Road
Mississauga, Ontario
L5S 1B1

(630) 627-6900
FAX (630) 627-1130

(905) 673-3222
FAX (905) 673-5161

987565
Printed in U.S.A.