



Electronic Service Manuals

This electronic document is provided as a service to our customers. We do not create the contents of the information contained in this document. Should you have detailed questions pertaining to the information contained in this document, you may contact Michco, or the manufacturer which provided the original information in this electronic deliverable. Michco's only part in this electronic deliverable was the electronic assembly process. By providing this manual on line we are not guaranteeing parts availability.

You may contact Michco through the following methods:

Phone (517) 484-9312 or (800) 331-3339

2011 N. High St. -- Lansing, Michigan -- 48906

Fax: (517) 484-9836

Email: CustServe@Michco.com

Web site: www.Michco.Com

Parts Web site: www.FloorMachineParts.Com

Order Parts on Line at:

www.FloorMachineParts.Com

Directly to Parts & Service:

By Email: **Shop@Michco.com**

By Fax: (517) 702-2041

By Voice: Use numbers above.

Serving the Cleaning Industry Since 1922

Notice: All copyrighted material remains property of original owners, all trademarks are property of respective owners. Manuals are subject to Manufacturer's reproduction limitations. Originals or reproductions were provided by manufacturers through a request. We make no warranty as to the correctness of information provided in this document and you assume all risk. By placing these manuals on line we are not declaring our corporation to be an manufacturer authorized dealer or provider, please check our web site for authorized manufacturers we represent.

User Manual

X17 ECO Carpet Extractor

This manual is furnished with each new **Minuteman X17**. This provides the necessary operating and preventive maintenance instructions. Operators must read and understand this manual before operating or servicing this machine.

This machine was designed to give you excellent performance and efficiency. For best results and minimal cost, please follow the general guidelines below:

- Operate the machine with reasonable care.
- Follow the manufacturer's suggested maintenance instructions as provided in this booklet.
- Use original Minuteman supplied parts.

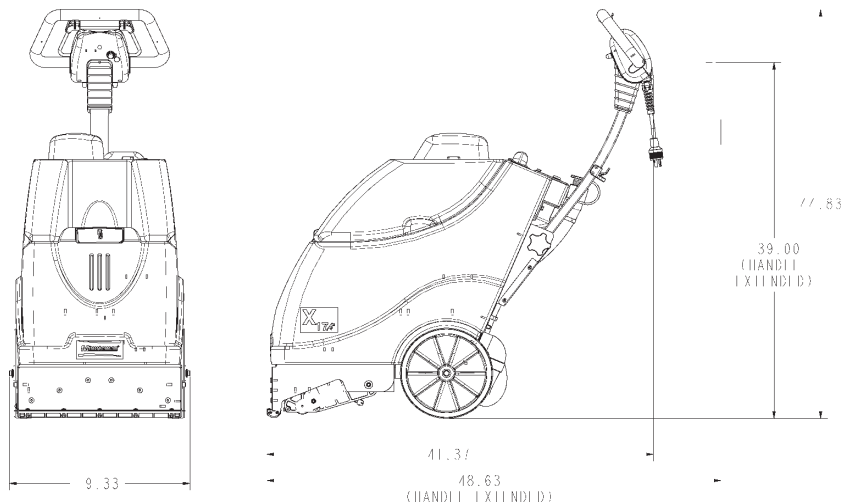

Model

X17 ECO

<u>Model No.</u>	<u>X17115</u>	<u>X17230</u>
Current Max.	12 Amps	7 Amps
Voltage	115V	230V
Vacuum motor power	1250W	1250W
Brush motor power	100W	100W
Pump motor power	50PSI	50PSI
Working width	17" (43cm)	17" (43cm)
Gross Weight	110 lbs.	110 lbs.
Solution tank	10 Gallon (37.8 LITERS)	10 Gallon (37.8 LITERS)
Recovery tank	7 Gallon (26.5 LITERS)	7 Gallon (26.5 LITERS)
Cable	50 ft.	50 ft.
Suction (sealed)	100 in. of water	100 in. of water
*Vibration	< 8.2 ft/s ²	< 2,5 m/s ²
Noise emission		
The sound pressure level measured under maximum conditions of use (LwA) according to DIN EN 60335-2-68		83 dB (A)
The sound pressure level measured (at the ear of the driver) under normal conditions of use (LpA) according to DIN EN 60335-2-68		72 dB (A)
Measurement inaccuracy (KpA)		1,8 dB (A)

*The frequency weighted acceleration measured according to DIN EN ISO 5349 which have an effect upon the upper limbs (hand-arm-system) amounts under normal working conditions.



DECLARATION OF CONFORMITY

MANUFACTURER'S NAME: Minuteman International Inc.

MANUFACTURER'S ADDRESS: 14N845 U.S. Route 20
Pingree Grove, IL. 60140 USA

EQUIPMENT DESCRIPTION: Electric Carpet Extractor

EQUIPMENT MODEL DESIGNATION: X17230

Application of Council Directives: EN60335-1, EN60335-2-68, EN50366, EN12100-1, EN12100-2, EN55014-1, 2004/108/EC, IEC/CISPR 14-1

Additional Standards: ISO 5349-1, ISO 5349-2

I, the undersigned, hereby declare that the equipment specified above conforms to the above Directive(s) and Standard(s).

SIGNATURE:

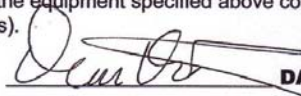
 **DATE:** 7/22/09

PRINTED NAME:
TITLE:

Dean Theobold
Vice President

Table of Contents

Technical Specifications	3
CE Declaration	4
Table Of Contents	5
Safety Instructions	6
For Safety During Operation	7
Unpacking Instructions	8
Assembly	10
Machine Overview	12
Front	12
Back	13
Handle\Control Panel	14
Circuit Breakers	14
Solution Tank In-line Filter	16
Solution Tank Drain Hose	17
Solution Level Indicator	17
Brush Pressure Gauge	18
Handle Adjustment	19
Accessories	20
Operating Instructions	21
Maintenance	22
Troubleshooting	24
Minuteman International Made Simple Commercial Limited Warranty	26

FOR COMMERCIAL USE ONLY

IMPORTANT SAFETY INSTRUCTIONS

When using an electrical appliance, basic precautions should always be followed, including the following:

READ ALL INSTRUCTIONS BEFORE USING

WARNING - To reduce the risk of fire, electric shock, or injury:

- Do not leave appliance when plugged in. Unplug from outlet when not in use and before servicing.

WARNING

To reduce the risk of electrical shock, do not expose to rain. Store indoors.

- Never allow children or untrained adults to operate this equipment.
- Keep the area of operation clear of all persons, particularly small children, and pets. Keep bystanders at least 25 feet away from the area of operation.
- Use only as described in this manual. Use only manufacturer's recommended attachments.
- Do not use with damaged cord or plug. If appliance is not working as it should, has been dropped, damaged, left outdoors, or dropped into water, return it to a service center.
- Do not pull or carry by cord, use cord as a handle, close a door on cord, or pull cord around sharp edges or corners.
- Do not run appliance over cord.
- Keep cord away from heated surfaces.
- Do not unplug by pulling on cord. To unplug, grasp the plug, not the cord.

- Do not handle plug or appliance with wet hands.
- Do not put any object into openings. Do not use with any opening blocked; keep free of dust, lint, hair, and anything that may reduce air flow.
- Keep hair, loose clothing, fingers, and all parts of body away from openings and moving parts.
- Do not pick up anything that is burning or smoking, such as cigarettes, matches, or hot ashes.
- Turn off all controls before unplugging.
- Use extra care when cleaning on stairs.
- Do not use to pick up flammable or combustible liquids such as gasoline or use in areas where they may be present.
- Connect to a properly grounded outlet only. See grounding instructions.
- If foam/liquid comes out of exhaust openings turn switch off immediately.
- Use only chemicals recommended by dealer/manufacturer.
- This machine must be used only with the power supply cord provided from the manufacturer
 - X17115 (748613)
 - X17230 (748613CE)

SAVE THESE INSTRUCTIONS

INSPECTION

Carefully unpack and inspect your machine for shipping damage. Each unit is tested and thoroughly inspected before shipment, and any damage is the responsibility of the delivery carrier who should be notified immediately.

ELECTRICAL

Model Number X17115 is designed to operate on a standard 115 amp, 115 volt, 60 hz, AC circuit. Voltages below 105 volts AC or above 125 volts AC could cause serious damage to the motor.

Model Number X17230 is designed to operate on a standard 10 amp, 230 volt, 50 hz, AC circuit. Voltages below 210 volts AC or above 250 volts AC could cause serious damage to the motor.

WARNING

Electric motors can cause explosions when operated near explosive materials or vapors. Do not operate this machine near flammable materials such as solvents, thinners, fuels, grain dust, etc.

GROUNDING INSTRUCTIONS

This floor-finishing machine shall be grounded while in use to protect the operator from electric shock. The machine is provided with a three-conductor cord and a three-contact grounding type attachment plug to fit the proper grounding type receptacle. The green (or green and yellow) conductor in the cord is the grounding wire. Never connect this wire to other than the grounding pin of the attachment plug.

DANGER

Improper connection of the equipment-grounding conductor can result in a risk of electric shock. Check with a qualified electrician or service person if you are in doubt as to whether the outlet is properly grounded. Do not modify the plug provided with the appliance — if it will not fit the outlet, have a proper outlet installed by a qualified electrician.

Model Number X17115 is for use on a nominal 115-volt circuit and has a grounding plug that looks like the plug illustrated in sketch A. Make sure that the appliance is connected to an outlet having the same configuration as the plug. No adapter should be used with this appliance.

Model Number X17230 is for use on a nominal 230-volt circuit and has a grounding plug that looks like the plug illustrated in sketch B. Make sure that the appliance is shown is connected to an outlet having the same configuration as the plug. No adapter should be used with this appliance.

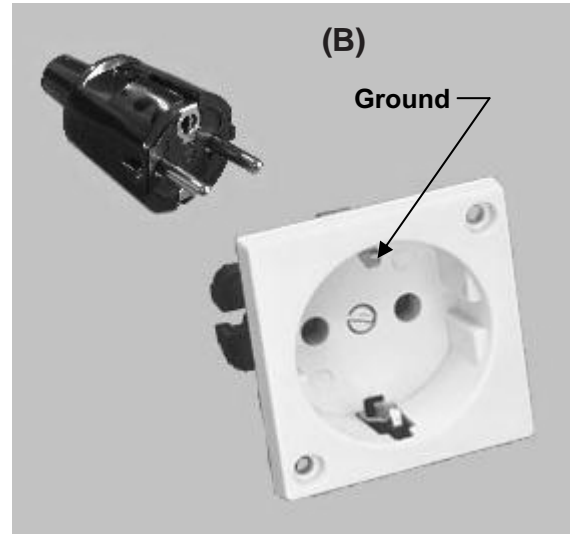
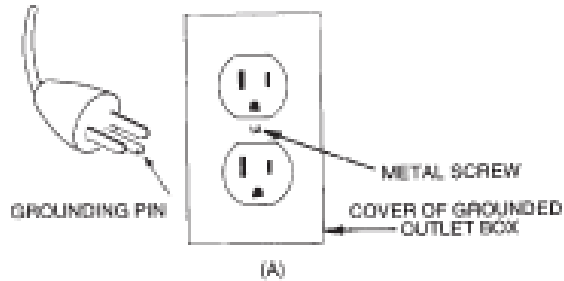

HANDLE ASSEMBLY

The X17 **Handle Assembly (D)** is not assembled on the machine when shipped. Follow the instruction on page 13 to connect the handle assembly to the machine.

- A HANDLE ADJUSTMENT KNOB
- B SHOULDER BOLT
- C COVER
- D HANDLE ASSEMBLY
- E SCREW
- F CORD RELIEF

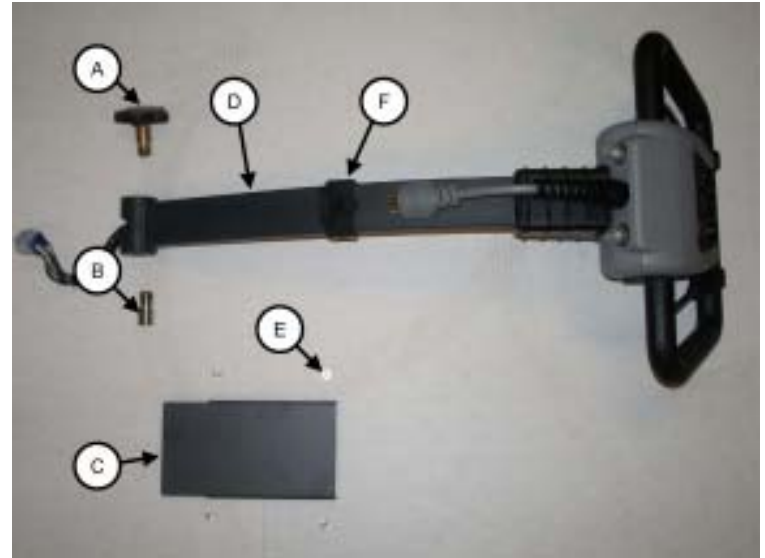



Unpack machine.



Use philips screwdriver to unscrew 4 screws and remove cover.



Insert handle assembly in between bushings. Insert the shoulder bolt through the bushing and screw into the handle assembly using supplied wrench.



Align the teeth on the bushing and handle assembly before tightening the adjustment knob.



Spin the adjustment knob clockwise to tighten.



Attach the wire harness to the machine.



The wire harness must be aligned with the patterns on the connector to fit.



Screw the cover back with the 4 screws.

X17 Front

- A HANDLE
- B RECOVERY DOME LID
- C RECOVERY TANK
- D SOLUTION TANK
- E SOLUTION TANK LID
- F WHEEL
- G RECOVERY WINDOW
- H CHASSIS ASSEMBLY
- J FAUCET FILL HOSE

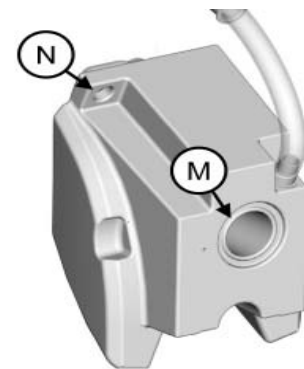
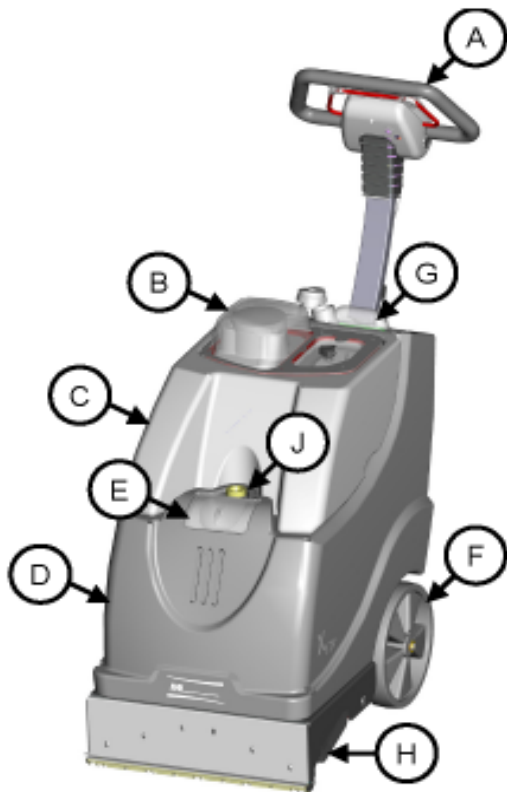

Vacuum Connection

- K VACUUM MOTOR INTAKE
- L VACUUM INTAKE CONDUIT
- M VACUUM INTAKE
- N RECOVERY INLET

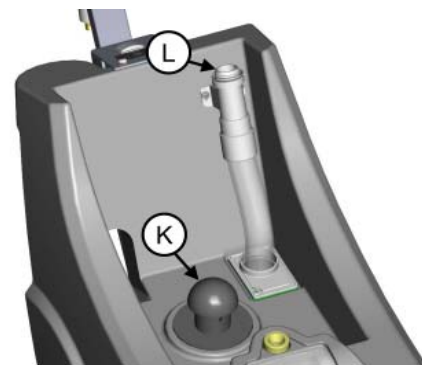

X17 Back & Bottom

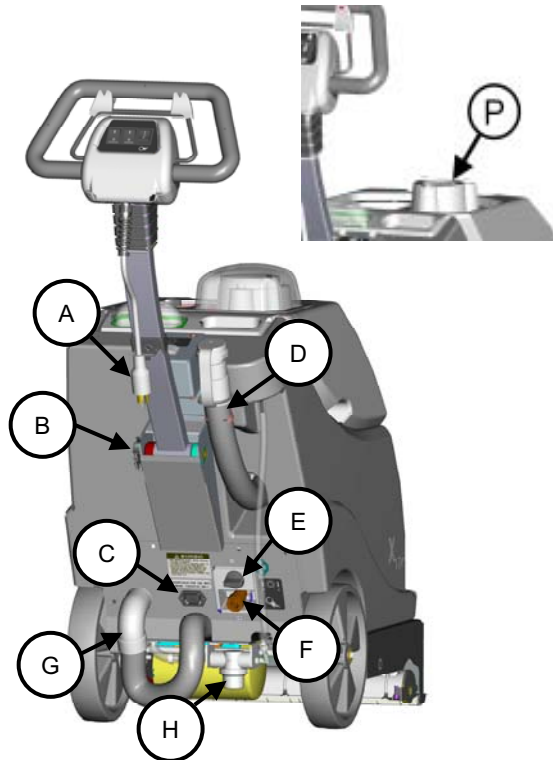

- A. (X17115) TWIST LOCK POWER CONNECTOR (SHOWN)
(X17230) POWER CONNECTOR
- B. HANDLE ADJUSTMENT KNOB
- C. AUXILLIARY POWER OUTLET
- D. RECOVERY TANK DUMP HOSE
- E. BRUSH PRESSURE ADJUSTMENT KNOB
- F. OFF AISLE WAND WATER FEMALE QUICK-CONNECT
- G. VACUUM HOSE
- H. IN-LINE FILTER
- J. VAC SHOE
- K. BRUSH
- L. BRUSH SHOE COVER
- M. SPRAY JETS (2)
- N. BRUSH MOTOR
- P. FLOAT SHUT-OFF

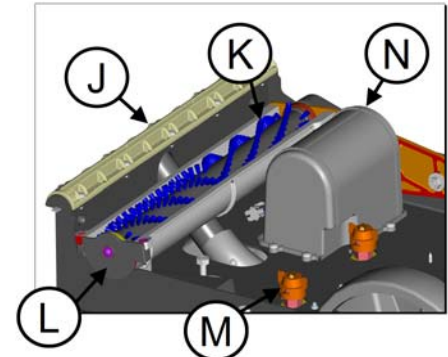

Handle/ Control Panel

- A MOMENTARY SPRAY BAIL
- B BRUSH SWITCH
- C VACUUM SWITCH
- D SPRAY JET \AUXILLIARY SWITCH



Circuit Breakers

The circuit breakers are located on bottom and rear of the handle assembly.

- 1 BRUSH MOTOR BREAKER - 3amp
- 2 VACUUM PUMP BREAKER - (X17115) 12amp
(X17230) 7amp
- 3 SPRAY JET PUMP\AUX POWER & PUMP BREAKER -
(X17115) 4amp
(X17230) 3amp

If any of the functions above are not operating, check if the circuit breaker buttons have tripped. Press to reset.

Momentary Handle

(A) When handle is pushed forward the spray jets shutoff.

Brush Switch

(B) ON/OFF switch for brush. Flip switch up to **(I)** position to power on the brush motor. Flip switch to **(o)** position to shut off brush motors. **Note: Brush switch must be turned ON for to use spray jets.**

Vacuum Switch

(C) ON/OFF switch for vacuum pump. Flip switch up to **(I)** position to turn on vacuum pump. Flip switch to **(o)** position to shut off pump.

Spray Jet/ Auxilliary Switch

(D) Power switch for spray jet and auxilliary switch. Push the switch to the **(I)** position to power ON the spray jets. **Note: The spray jets will not work unless the brush is powered ON.** Push switch to **(II)** position to use the Off-aisle wand. This will power the auxilliary outlet and will turn the pump on for the auxilliary connection. See page 20 for connection details.

Make sure to turn off the brush switch when this switch is in the auxillary mode.

Solution Tank In-line Filter

The **In-line Filter (B)** should be cleaned regularly. To remove, turn the **Shut-off Valve (C)** closed by turning it 90° clockwise. Next, twist the **Filter Cap (A)** counter-clockwise and pull the filter out to clean.

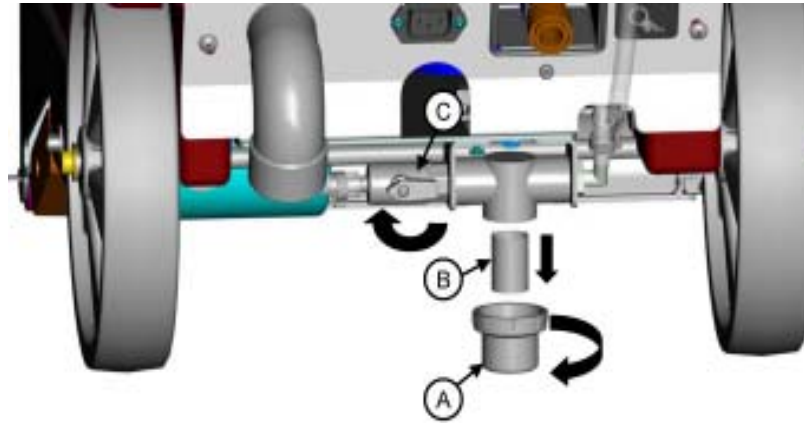

Solution Tank Drain Hose

The solution tank may be drained by removing the **Solution Tank Drain Hose (A)** from the **Hose Barb (B)** and routing the hose to a floor drain.

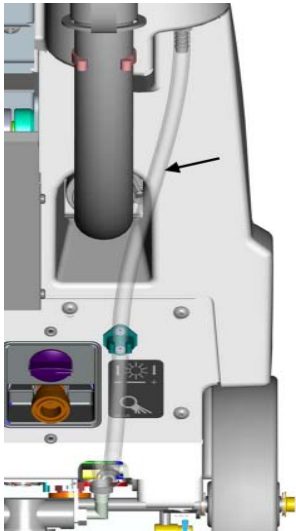

Solution Level Indicator

The solution Tank Drain Hose also serves as a water level indicator for the solution tank. The amount of water remaining in the solution tank can be seen through the clear drain hose.

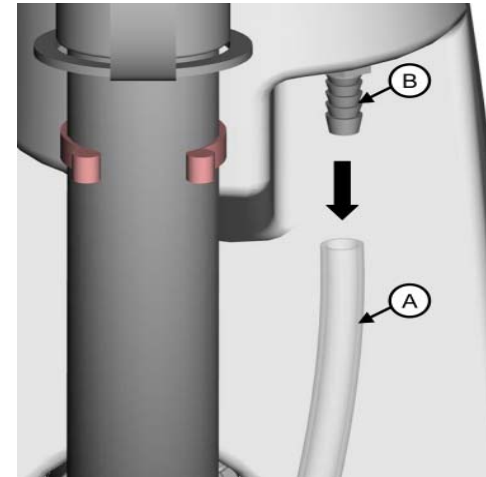

Brush Pressure Gauge

The brush pressure gauge informs the operator if the brush pressure setting is in optimum range. The machine operates best in the green area. If the machine reaches the yellow or red range the brush pressure can be lowered by raising the brush by turning the brush pressure adjustment knob counter-clockwise.





Handle Adjustment

The X17 handle was designed with operator comfort in mind. The angle position of the handle can be adjusted to suit the needs of the operator.

Angle Adjustment

The handle can be adjusted without tools by loosening the **Handle Adjustment Knob (A)** and rotating the handle to the desired position.

Cord Relief

Use cord relief to prevent cables from disconnecting. Lock the cord in place by looping the cable and threading the cable through the relief, then pull the cable down so it locks into place as shown in figure 2.



Figure 1



Figure 2

Machine Overview

Accessories



(X17115) C46300-00 - Motorized Tool

(X17230) C46300-02 - Motorized Tool

Only this tool may plug into the **Auxiliary Power (B)**.

The vacuum hose as shown on Page 13 Item (G) must be first disconnected from the machine before the motorized tool can be connected. Connect the tools Suction Hose (D) to the machines Vacuum Inlet (A) Connect the motorized tool Power Cord (E) to the Auxiliary Power (B). A Coupler-quick Connect (G) (p/n: 450295) is required to connect the tool's Solution Hose (F) to the quick-connect Solution Coupling (C). To turn ON the tool the auxiliary switch must be in the (II) position as shown on Page 14 Item (D). The vacuum switch must also be turned on when using the motorized tool.



TM1001 - Upholstery Tool

The same applies to the upholstery tool except this tool does not require auxiliary power to be used.

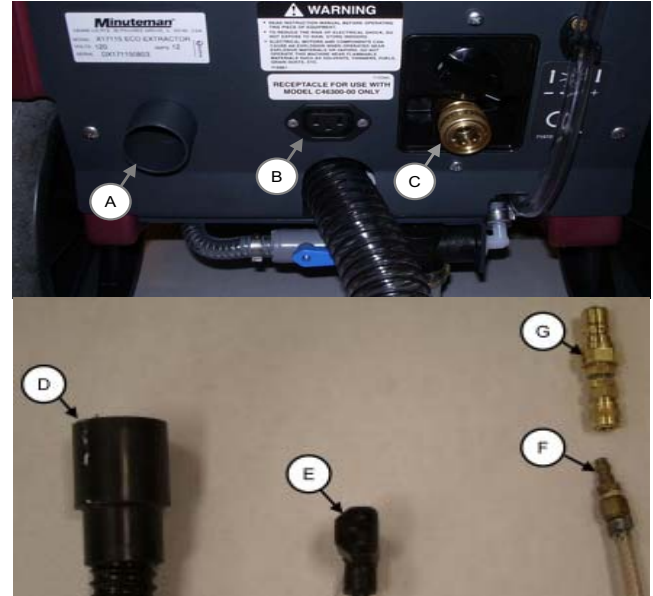

Caution! Brush motor must be turned OFF when using auxiliary function. If the brush motor is ON, water will continue to spray from the spray jets, causing reduction in water pressure to auxiliary tool.

OPERATING INSTRUCTIONS

FILLING THE X17

Remove clear solution cover lid from front of machine, refer to machine overview section, or use the supplied faucet fill hose, item J. Fill solution tank with desired amount of warm water and add liquid cleaning chemical, Minuteman Extraction Shampoo order #902163. (See instructions on container for proper dilutions.) DO NOT USE powdered cleaning chemicals. Powders are unlikely to dissolve thoroughly, resulting in clogging the inline solution strainer. This can reduce or stop solution flow to the pump and spray jets.

Carpet should be thoroughly vacuumed and obstacles relocated before beginning the cleaning cycle. Heavy traffic lane areas should be pre-treated or spotted with Minuteman Pre-Treat order #902183 for best results.

TO BEGIN CLEANING:

1. Always work away from the cord.
2. Machine operates by pulling backwards over carpet.
3. The recovery dome lid, page 12, item B, should be properly seated on Recovery Tank, item C, for proper vacuum recovery.
4. See page 14, Control Panel Switch Identifications:
Normal Cleaning Mode
 1. Turn on vacuum switch (C).
 2. Turn on brush switch (B).
 3. Turn on the solution pump (D). **Note: The spray jets will not work unless the brush is powered ON.**
 4. Adjust brush pressure at rear of machine, until brush pressure gauge reads in green zone.
 5. Solution pump should be turned off by either using the momentary bail, item A, or flip the switch to the center position, page 14, item D, 6" before the end of each cleaning pass.

During the cleaning cycle, care should be taken not to allow foam to build up in the recovery tank. If this should happen, the machine should be turned off. Defoamer order #910543 should be added to the recovery tank only, never into the solution tank. Foam should not be allowed to enter vacuum filter screen.

The recovery water level can be viewed from the operator's position of the machine through the visible recovery dome. The X17 has a float ball shut off located in the recovery tank that cuts off suction to the vacuum hose. The machine will get louder when the recovery tank is full. (NOTE : Never tilt machine completely back with recovery tank in place. Always remove tank and set to the side before tilting complete machine.) To empty the recovery tank use the recovery tank dump hose, page 13, item D. Unclip the hose from the tank and turn the cap a quarter turn counter-clockwise and dump waste water into a floor drain or slop sink.

USER MAINTENANCE INSTRUCTIONS

All service and repair should be performed by qualified service representative or electrician. No user serviceable components are employed in the electrical assembly. No lubrication of the motor is required. Before cleaning or maintaining the machine unplug the electrical supply plug.

DAILY MAINTENANCE

1. Solution tank should be emptied after each use. Flush pumping system with 2 or 3 gallons of clean hot water.
2. Vacuum shoe should be cleaned of any debris daily.
3. Removable recovery tank, page 12, item C, should be rinsed clean daily (leave clean cover removed when storing).
4. Spray jets should be checked for correct spray pattern and cleaned if plugged. Spray jets are quick release 1/4 turn type. By twisting item 1/4 turn counter clockwise, jets can be removed for cleaning. Do not clean out spray tips with pins or wire, this may cause damage to the jet spray pattern and cause streaking.
5. Protect equipment from freezing. Severe pumping system damage can occur if allowed to freeze.
6. Inspect vacuum hoses for tight connections. Check electrical cable for abrasion or cuts in jacket. Cord should be replaced if worn or damaged.
7. Remove carpet string from brush daily.

MONTHLY/BI-MONTHLY MAINTENANCE

The X17 Solution Pump System should be purged twice monthly to remove alkaline residue build-up. The system should be flushed twice, once with the jets installed and once with jets removed. To flush system out, use 1 quart of white vinegar to two gallons of clean hot water, followed by a clear 2 gallon rinse. Clean spray jets if required. The recovery window must be removed and cleaned monthly. To remove the recovery window unscrew the 2 screws. When replacing the recovery window make sure there is a water tight seal between the gasket and the tank. The recovery tank air filter located on top of the recovery tank under the lid needs to be cleaned monthly. To clean filter remove the recovery dome lid then unscrew the 3 thumb screws located on the float shut off remove filter and rinse clean. There is also a screen located inside the float shut off that needs to be removed and cleaned weekly.

CORD STORAGE

The X17 is supplied with a detachable cord for ease of storage.

- Regularly inspect cord for signs of damage. If cord is damaged replace immediately.
- Do not use with damaged cord or plug. If appliance is not working as it should, has been dropped, damaged, left outdoors, or dropped into water, return to service center.
- Do not pull or carry by cord, use cord as handle, close a door on cord, or pull cord around sharp edges or corners. Do not run appliance over cord. Keep cord away from heated surfaces.
- Do not unplug by pulling cord. To unplug, grasp the plug, not the cord.
- Do not handle plug or appliance with wet hands.
- This equipment should be stored indoors and not exposed to rain.

Troubleshooting Guide

Caution! Unplug power cord before servicing machine components.

Problem	Possible Cause	Remedy
Machine does not function	Power cord may be disconnected at the twist lock or wall outlet.	Check connections and reconnect if necessary.
	Wall outlet breaker may have tripped	Reset breaker.
No water dispensed from spray jets	Circuit breaker tripped.	Reset breaker.
	Solution tank in-line filter valve may be closed.	Open valve.
	Sprayjet Switch is in OFF (O) or AUX (II) position	Flip sprayjet switch to ON (I) position.
	Brush switch is not ON	Flip brush switch ON (I)
	No water in solution tank.	Fill solution tank.
Spray intermittent or streaked	Solution hoses may be clogged or kinked.	Check hose for clogs, remove any debris if found. Replace kinked hose if found.
	Solution tank in-line filter may be clogged.	Clean strainer thoroughly.
	The spray jets may be clogged.	Remove the spray tips and clean as required. Do not clean out the hole in the jet with a pin or wire. This may cause permanent streaking.
Brush does not turn ON	Circuit breaker tripped.	Reset breaker.
	Belt is damaged	Replace belt
	Debris is lodged in the housing	Remove debris
	Switch is in OFF (O) position	Flip switch to ON (I) position.

Solution recovery is reduced	Recovery dome lid is not seated properly.	Reposition dome lid
	Recovery tank is not seated properly over intake tube.	Reposition recovery tank so the intake tube is inserted into the inlet.
	Recovery tank dump hose may not be closed properly.	Disconnect cap from drain hose then reconnect, to ensure the cap and hose snap together.
	Bad seals on recovery dome lid.	Check the gasket on the lid for damage. Replace if needed.
	Vac shoe may be clogged.	Check vac shoe for debris and remove if necessary.
	Vac shoe may be worn.	Replace vac shoe.
Vacuum motor does not start.	Circuit breaker may have tripped.	Reset breaker.
	Motor carbon brush may be worn.	Contact a qualified service technician.
	Switch is in the OFF (O) Position	Flip the switch to the ON (I) Position

Minuteman International Made Simple Commercial Limited Warranty REVISION F EFFECTIVE 6/1/2009

Minuteman International, Inc. warrants to the original purchaser/user that the product is free from defects in workmanship and materials under normal use. Minuteman will, at its option, repair or replace without charge, parts that fail under normal use and service when operated and maintained in accordance with the applicable operation and instruction manuals. All warranty claims must be submitted through and approved by factory authorized repair stations.

This warranty does not apply to normal wear, or to items whose life is dependent on their use and care, such as belts, cords, switches, hoses, rubber parts, electrical motor components or adjustments. Parts manufactured by Minuteman are covered by and subject to the warranties and/or guarantees of their manufacturers. Please contact Minuteman for procedures in warranty claims against these manufacturers.

Special warning to purchaser — Use of replacement filters and/or prefilters not manufactured by Minuteman or its designated licensees, will void all warranties expressed or implied. A potential health hazard exists without original equipment replacement.

All warranted items become the sole property of Minuteman or its original manufacturer, whichever the case may be.

Minuteman disclaims any implied warranty, including the warranty of merchantability and the warranty of fitness for a particular purpose. Minuteman assumes no responsibility for any special, incidental or consequential damages.

This limited warranty is applicable only in the U.S.A. and Canada, and is extended only to the original user/purchaser of this product. Customers outside the U.S.A. and Canada should contact their local distributor for export warranty policies. Minuteman is not responsible for costs or repairs performed by persons other than those specifically authorized by Minuteman. This warranty does not apply to damage from transportation, alterations by unauthorized persons, misuse or abuse of the equipment, use of non-compatible chemicals, or damage to property, or loss of income due to malfunctions of the product.

If a difficulty develops with this machine, you should contact the dealer from whom it was purchased.

This warranty gives you specific legal rights, and you may have other rights which vary from state to state. Some states do not allow the exclusion or limitation of special, incidental or consequential damages, or limitations on how long an implied warranty lasts, so the above exclusions and limitations may not apply to you.

Cord Electric Group: Three years parts, two years labor, ninety days travel (Not to exceed two hours)

Exceptions.....

<u>Model</u>	<u>Parts</u>	<u>Labor</u>	<u>Poly</u>	<u>Travel</u>
Port A Scrub	1 yr	6 months	10 yrs	0
MPV 13	1 yr	0	0	0
MPV 14 & 18	2 yrs	1 yr	0	0
V Series Upright Vacuums	1 yr	1yr	0	0
Rapid Air Blower	1 yr	1 yr	10 yrs	0
Explosion Proof Vacuum	1 yr	1 yr	0	0
X12, X12H & TRS 14	1 yr	1 yr	10 yrs	0
E17 & E20 Electric Scrubbers	1 yr	6 months	10 yrs	0
Pneumatic Vacuums	3 yr	1 yr	0	0

<u>Description</u>	<u>Parts</u>	<u>Labor</u>	<u>Poly</u>	<u>Travel</u>
Battery Operated Group	3 yrs	2 yrs	10	90 days
Sweepers	1 yr	1 yr	10	90 days
Internal Combustion Group	1 yr	1 yr	10	90 days

Not to exceed two hours

Exception: PAS 14B **1 yr** **1 yr** **10 yr** **0**

Battery Chargers:

One year replacement

Replacement Parts:

Ninety days

Batteries:

0-3 months replacement, 4-12 months pro-rate

Polyethylene Plastic Tanks:

Tanks have 10yr warranty, no additional labor

Minuteman[®]



Excellence Meets Clean

Minuteman International · 14N845 U.S. Route 20 · Pingree Grove, Illinois 60140 USA

Phone 800- 237-3192

E-Mail, www.minutemanintl.com

A Member of the Hako Group

**988725UM
Rev B 07/09**