



# Electronic Service Manuals

This electronic document is provided as a service to our customers. We do not create the contents of the information contained in this document. Should you have detailed questions pertaining to the information contained in this document, you may contact Michco, or the manufacturer which provided the original information in this electronic deliverable. Michco's only part in this electronic deliverable was the electronic assembly process.

You may contact Michco through the following methods:  
Phone (517) 484-9312 or (800) 331-3339 MI, OH, IN only  
2011 N. High St. -- Lansing, Michigan -- 48906  
Fax: (517) 484-9836  
Email: [CustServ@Michco.com](mailto:CustServ@Michco.com)  
Web site: [www.Michco.Com](http://www.Michco.Com)  
Parts Web site: [www.FloorMachineParts.Com](http://www.FloorMachineParts.Com)

Order Parts on Line at:  
**[www.FloorMachineParts.Com](http://www.FloorMachineParts.Com)**

Directly to Parts & Service:  
By Email: **[Shop@Michco.com](mailto:Shop@Michco.com)**  
By Fax: (517) 702-2041  
By Voice: Use numbers above.

**Serving the Cleaning Industry Since 1922**

Notice: All copyrighted material remains property of original owners, all trademarks are property of respective owners. Manuals are subject to Manufacturer's reproduction limitations. Originals or reproductions were provided by manufacturers through a request. We make no warranty as to the correctness of information provided in this document and you assume all risk.

# Automatic Carpet Scrubber

Model: C840115  
C840240

■ OPERATION ■ SERVICE ■ PARTS ■ CARE

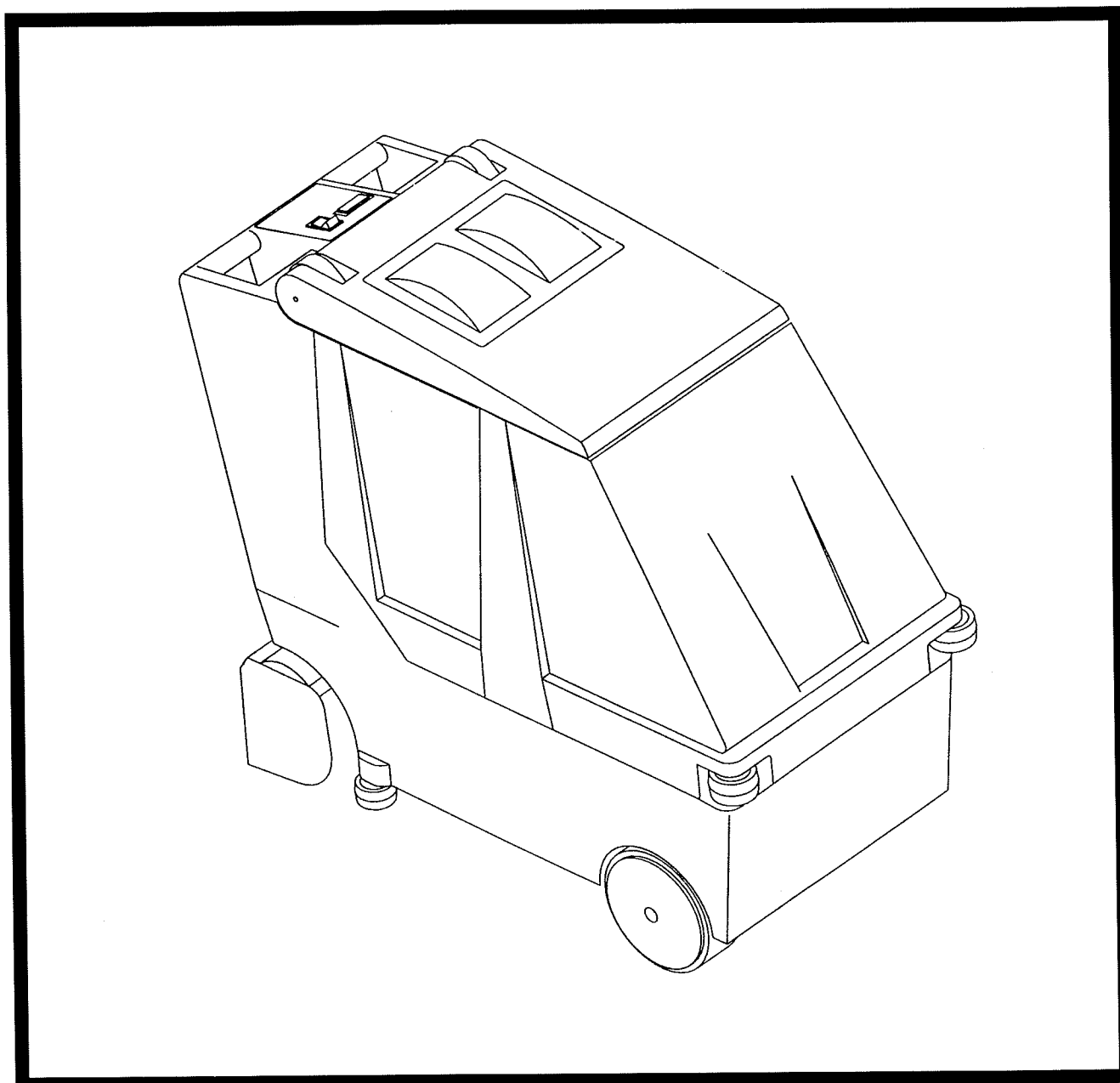

Revised 7/98

**Minuteman<sup>®</sup>**

## TABLE OF CONTENTS

	<b>Page</b>
Safety Instructions	1
Electrical Requirements	2 - 5
Control Panel Identification and Instructions	6
Operating Instructions	7
Tank Parts	8 - 9
Lower Structure Parts	10 - 13
Scrub Head Assembly Parts	14 - 15
Trouble Shooting Instructions	16 - 17

# **FOR COMMERCIAL USE ONLY**

## **IMPORTANT SAFETY INSTRUCTIONS**

When using an electrical appliance, basic precautions should always be followed, including the following:

### **READ ALL INSTRUCTIONS BEFORE USING**

#### **WARNING - To reduce the risk of fire, electric shock, or injury:**

- Do not leave appliance when plugged in. Unplug from outlet when not in use and before servicing.

#### **WARNING**

To reduce the risk of electrical shock - Do not expose to rain. Store indoors.

- Do not allow to be used as a toy. Close attention is necessary when used by or near children.
- Use only as described in this manual. Use only manufacturer's recommended attachments.
- Do not use with damaged cord or plug. If appliance is not working as it should, has been dropped, damaged, left outdoors, or dropped into water, return it to a service center.
- Do not pull or carry by cord, use cord as a handle, close a door on cord, or pull cord around sharp edges or corners. Do not run appliance over cord. Keep cord away from heated surfaces.
- Do not unplug by pulling on cord. To unplug, grasp the plug, not the cord.
- Do not handle plug or appliance with wet hands.
- Do not put any object into openings. Do not use with any opening blocked; keep free of dust, lint, hair, and anything that may reduce air flow.
- Keep hair, loose clothing, fingers, and all parts of body away from openings and moving parts.
- Do not pick up anything that is burning or smoking, such as cigarettes, matches, or hot ashes.
- Do not use without dustbag and/or filters in place.
- Turn off all controls before unplugging.
- Use extra care when cleaning on stairs.
- Do not use to pick up flammable or combustible liquids such as gasoline or use in areas where they may be present.
- Connect to a properly grounded outlet only. See grounding instructions.

### **SAVE THESE INSTRUCTIONS**

# INSPECTION

Carefully unpack and inspect your machine for shipping damage. Each unit is tested and thoroughly inspected before shipment, and any damage is the responsibility of the delivery carrier who should be notified immediately.

# WARNING

- Read Instruction Manual before operating this piece of equipment.
- To reduce the risk of fire use only commercially available floor cleaners and waxes intended for machine application.
- Electrical motors and components can cause an explosion when operated near volatile materials and vapors. Do not use this machine near flammable materials such as solvents, thinners, fuels, grain dust, etc.

## ELECTRICAL - 115 Volt Model C840115

This machine is designed to operate on a standard 15 amp. 120 volt, 60 hz, AC circuit. Voltages below 105 volt AC or above 125 volts AC could cause serious damage to the motor.

## ELECTRICAL - 240 Volt Model C840240

This machine is designed to operate on a standard 16 amp. type L fused 230 volt, 50 hz, AC circuit. Voltages below 200 volt AC or above 250 volts AC could cause serious damage to the motor.

# GROUNDING INSTRUCTIONS

- This floor finishing machine should be grounded while in use to protect the operator from electric shock. The machine is equipped with a three-conductor cord and a three-prong grounding type attachment plug to fit the proper grounding type receptacle. The green (or green and yellow) conductor in the cord is the grounding wire. Never connect this wire to other than the grounding blade.
- Floor Finishing Machines Rated Less Than 150 Volts - If the machine is provided with an attachment plug as shown in Sketch A it is intended for use on a 120-volt (nominal) circuit. If a properly grounded receptacle as shown in Sketch A is not available, an adapter as shown in Sketch C is available and should be installed as shown in Sketch B if the outlet box that houses the receptacle is grounded. Be sure to fasten the grounding tab with the faceplate screw.
- Floor Finishing Machines Rated More Than 150 Volts - If the machine is provided with an attachment plug as shown in Sketch D, it is intended for use on a nominal 240 volt circuit. No adapter is available for this plug.

### ADAPTER (Not applicable in Canada)

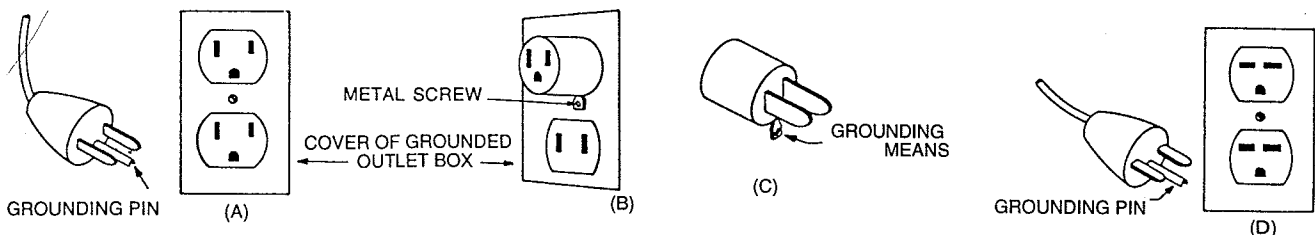

# POUR USAGE COMMERCIAL SEULEMENT

## MODE D'EMPLOI SECURITAIRE

Lorsque l'on utilise un appareil électrique, des précautions de base doivent toujours être suivies telles que:

### BIEN LIRE LE MODES D'EMPLOI AVANT USAGE

**AVERTISSEMENT** - Pour réduire les risques de feu, choc électrique ou blessure:

- Ne pas quitter l'appareil lorsque la prise de courant est branchée. Débrancher de la sortie électrique lorsque la machine n'est pas en usage ou pour en faire le service.

**AVERTISSEMENT** - Pour réduire le risque de choc électrique - Ne pas exposer à la pluie - Entreposer à l'intérieur.

- Ne pas permettre l'usage comme jouet. Etre très prudent lorsque l'appareil est utilisé en présence d'enfants.
- Utiliser tel que prescrit dans le livre d'opération et seulement avec les attachements recommandés par le manufacturier.
- Ne pas s'en servir avec corde ou prise de courant endommagée. Si l'appareil ne fonctionne pas ou a été échappé, endommagé, entreposé à l'extérieur ou déposé dans l'eau, l'appareil devrait être envoyé à un département de service pour inspection.
- Ne pas tirer ou porter par le câble ou se servir du câble comme poignée. Ne pas fermer de portes sur le câble ou tirer le câble près d'objets pointus. Ne pas conduire l'appareil en écrasant le câble et soyez certain de protéger le câble entre toutes surfaces de chauffage.
- Ne pas débrancher en se servant du câble. Pour débrancher tirer sur la prise et non sur le câble.
- Ne pas manipuler la prise ou l'appareil avec les mains mouillées.
- Ne placer aucun objet dans la sortie et ne pas s'en servir si la sortie est obstruée. Eliminer toute poussière, maillon, cheveux ou quoique ce soit qui pourrait réduire le mouvement d'air.
- N'exposer aucun cheveux, vêtement, doigts ou autres aux ouvertures de l'appareil.
- Ne rien ramasser de ce qui brûle ou de fumée tels que cigarettes, allumettes ou cendres en feu.
- Ne pas employer sans filtre de poussière ou autre en position.
- Fermer tous les contrôles après utilisation.
- Soyez très prudent lors du nettoyage d'escaliers.
- Ne pas ramasser de liquide inflammable ou combustible tel que gazoline et ne pas utiliser dans les endroits ou ces derniers pourraient être présent.
- Brancher dans une prise avec une prise de terre seulement. Voir références pour prise de terre.

**CONSERVEZ CES RECOMMANDATIONS  
DE MODE D'EMPLOI**

## INSPECTION

Déballer soigneusement en constatant s'il y a lieu tout dommage apparent. Chacune des pièces d'équipement est entièrement inspectée à l'usine et tout dommage de transit est la responsabilité de la compagnie de transport qui devrait être prévenue immédiatement.

## AVERTISSEMENT

- S.V.P. lire le manuel d'instruction avant d'opérer cette pièce d'équipement.
- Pour réduire le risque d'incendie, se servir de ces appareils uniquement pour usage commercial et avec les produits construits spécifiquement pour usage avec ces appareils.
- Les moteurs électriques peuvent être la cause d'explosion si ils sont utilisés près de matériaux ou de vapeurs explosives. Ne pas opérer près de matériaux inflammables tels que solvant, essence, poussière de grain etc.

## ELECTRICITE - 115 Volt, Modèles C840115

Ces appareils sont conçus pour opérer sur un circuit standard de 15 amp. 120 volt, 60 hz, circuit AC. Tout voltage en bas de 105 volts AC ou au delà de 125 volts AC pourrait occasionner des dommages au moteur.

## ELECTRICITE - 240 Volt, Modèles C840240

Ces appareils sont conçus pour opérer sur un circuit standard AC de 16 amp., fusible type L 230 volt, 50 hz. Tout voltage en bas de 200 volts AC ou au delà de 250 volts AC pourrait occasionner des dommages au moteur.

## INSTRUCTIONS POUR PRISE DE TERRE

- Ces appareils doivent posséder une prise de mise à terre pour protéger l'opérateur contre les chocs électriques. Cet appareil est muni d'une corde électrique à trois fils et d'un receptacle à trois fourchons et prise de mise à terre pour s'accorder dans un receptacle avec prise de mise à terre réciproque. Le fil conducteur vert (ou vert et jaune) de la corde électrique est le fil designé comme prise de mise à terre. Ne jamais relier ce fil à un fil autre que celui de prise de mise à terre.
- Appareils estimés à moins de 150 volts - Si ces appareils offrent une prise de courant tel que dans le croquis A, ils sont destinés pour utilisation avec un circuit de 120 volts. Si un receptacle avec prise de mise à terre n'est pas disponible tel que montré au croquis A, un adapteur tel que vu au croquis C est disponible et devrait être installé tel que montré au croquis B si la boîte électrique est munie d'une prise de mise à terre. Assurez-vous de bien relier la patte de prise avec la vis.
- Appareils destinés à plus de 150 volts - Si ces appareils offrent une prise de courant tel que démontré au croquis D, ils doivent être utilisés avec un circuit de 240 volts. Aucun adapteur n'est disponible pour cette prise.

ADAPTEUR (Non requis au Canada)

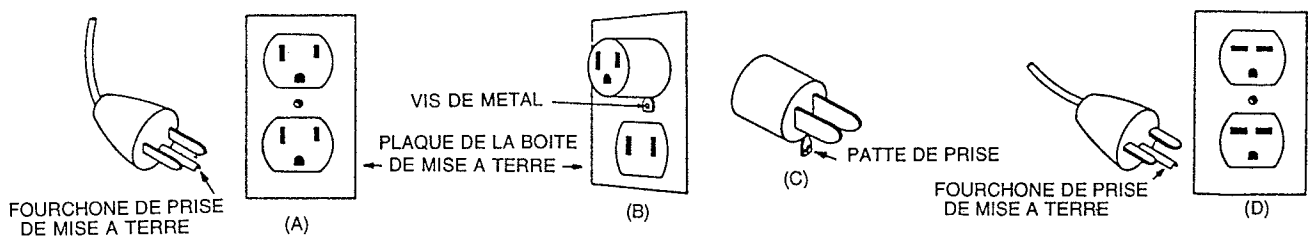



## OPERATOR VIEW OF CONTROLS

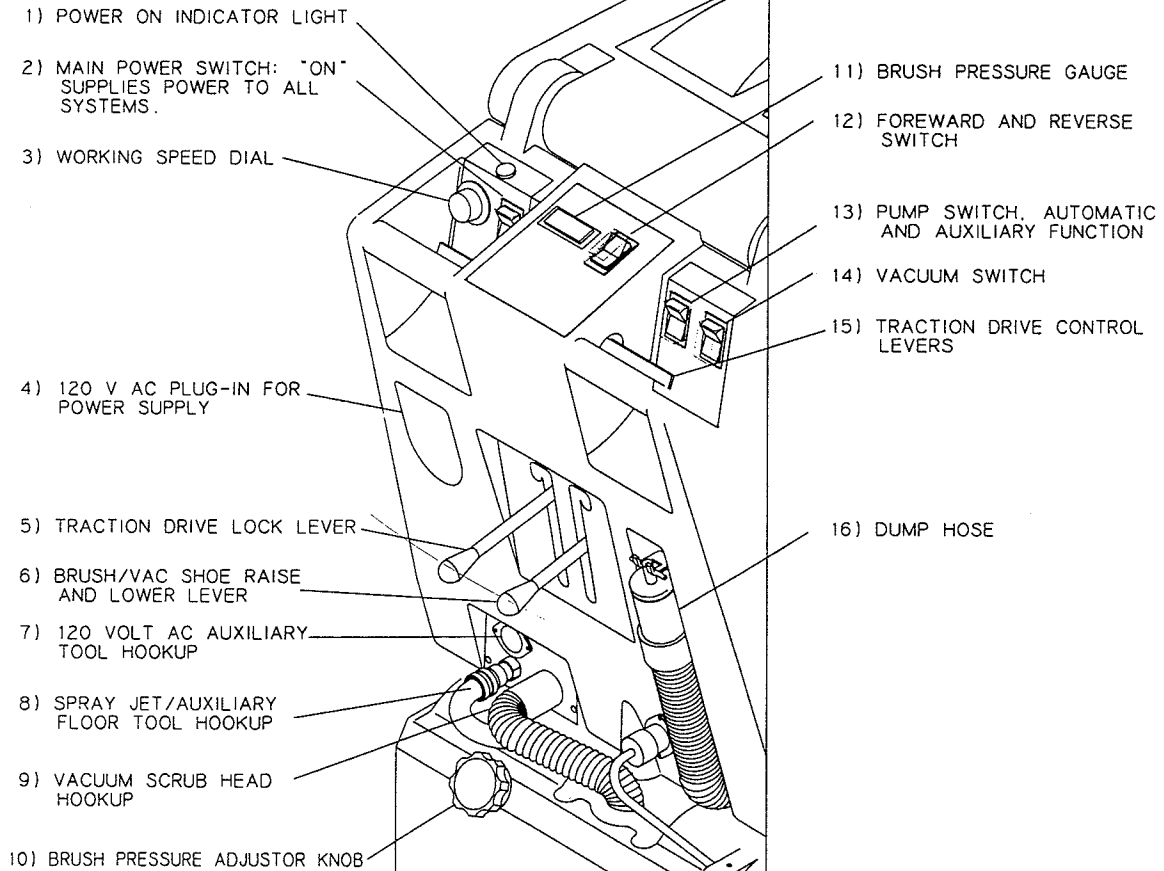

# OPERATING INSTRUCTIONS

1. Filling: Fill the solution tank with the desired amount of water and add liquid cleaning solution to the proper dilution ratio. DO NOT USE powdered cleaning chemicals. Powders are unlikely to dissolve thoroughly, resulting in clogging the inline solution filter. This can reduce or stop water flow to the pump and spray jets.
2. Connect power supply cord to grounded wall outlet, Item #4.
3. Engage traction drive system, Item #5
4. Turn on main power switch, Item #2.
5. Lower scrub head assembly, Item #6.
6. Turn on pump switch to automatic, Item #13.
7. Turn on vacuum, Item #14.
8. Set forward/reverse switch to forward, Item #12.
9. Engage traction drive control levers, Item #15.
10. Adjust forward speed #3.
11. Brush pressure can be adjusted + or - by knob, Item #10, and viewing gauge, Item #11, in green zone.

## Accessory Attachments:

1. Turn master switch off.
2. Disconnect vac hose, Figure 1, Item #9 and attach vacuum hose from remote tool.
3. Disconnect solution hose, Figure 1, Item #8 and install remote tool solution hose to quick disconnect turn pump solution switch, Figure 1, Item #13 to auxiliary.
4. If electric power head is used, attach power cable to Item #7, Figure 1 electrical outlet.
5. Turn on main power switch.
6. Turn on switch #14 to activate vacuum motor.

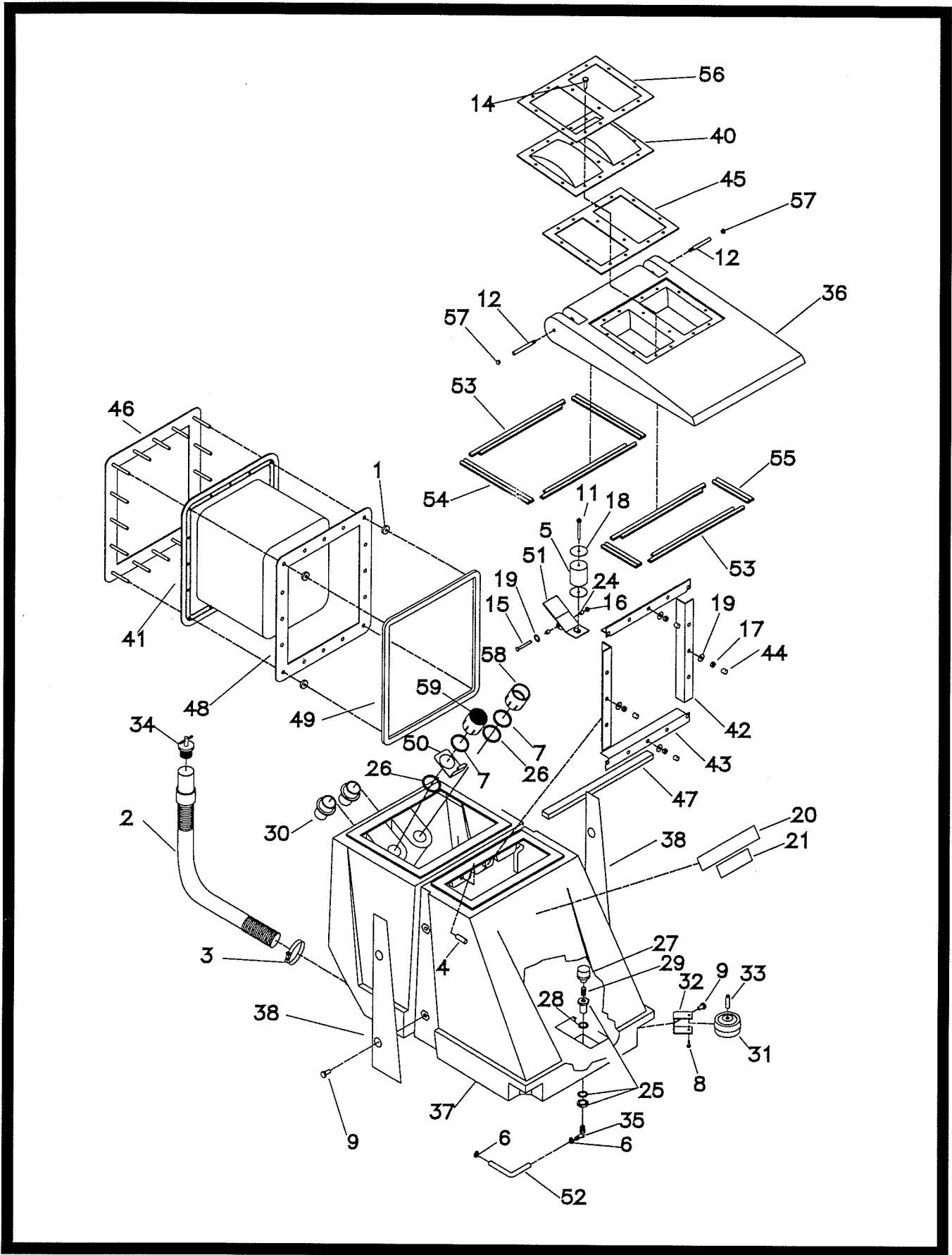

# PARTS LIST

Item	Part No.	Qty.	Description
1	130029	4	Grommet .75 x .31 x .25
2	260202	1	Hose Assembly 260B New Style
3	260203	1	Hose Clamp 102120 Murray
4	420013	1	Tube 1/2 x 3
5	430089	1	Float 17B
6	450076	2	Crimp Clamp SS 185R
7	450081	2	WSR-SS 1.908 x 2.41 x .03
8	710353	2	SCR-MC 10-32 x.37 ST PL
9	710985	6	SCR-SC 3/8-16 x .62
11	712092	1	SCR-Nylon 1/4 20 x 2.5
12	712107	2	SCR-Shoulder 1/4 - 20 x 2.87
14	712537	14	SCR-MC 10 - 24 x .75 SS
15	712567	1	SCR-MC 1/4 -20 x 2.00 SS
16	712667	1	Nut-Hex 1/4-20 SS Nyloc
17	712680	16	Nut-Hex 5/16-18 SS
18	712759	2	WSR-Flat .31 x .137 x .06 SS
19	712767	26	WSR-Flat .406 x .75 SS
20	715060	1	Decal Diecut "Minuteman"
21	715091	1	Decal Diecut Minuteman ACS
22	715624	1	Decal Side Cover L
23	715625	1	Decal Side Cover R
24	762384	2	Bushing SS .277 x .375 x .37
25	828945	1	Bulkhead Fitting 1/4 x 3/4
26	828970	2	WSR-Neop 1.87 x 2.4 x .125
27	828974	1	Strainer
28	828975	1	WSR-Neop .75 x 1.5 x .09
29	828981	1	Brass Nipple 1/4
30	831812	2	Adapter 1.5 MPT x 1.5 HB AB
31	832896	2	Guide Wheel ACS II
32	832949	2	Bracket Bumper
33	833254	2	Bumper Wheel Axle
34	833316	1	Drain Plug
35	833325	1	Elbow PLS 1/4 MPT x 3/8 BARB
36	840001	1	Tank Lid, ACS 20
37	840002	1	Solution/Recovery Tank ACS 20
38	840113	2	Side Panel
40	840017	1	Dome Air/Water
41	840051	1	Bladder Bag ACS 20"
42	840054	2	Angle, Bladder Side
43	840055	2	Angle, Bladder Top/Bottom
44	840059	16	Cap - Thread Cover
45	840061	1	Gasket ACS Dome
46	840063	1	Frame Bladder Mount
47	840069	1	Pocket Gasket ACS
48	840070	1	Washer Plate Assembly
49	840071	1	Gasket Solution/Recovery ACS 20
50	840074	1	Valve Pivot Bracket
51	840075	1	Float Valve ACS 20"
52	840082	1	Hose 3/8 ID x 24.00
53	840084	4	Gasket Lid Front/Back
54	840085	2	Gasket Lid Long
55	840086	2	Gasket Lid Short
56	840087	1	Cover Plate/Dome
57	840095	2	Plug Dome - Heyco .312
58	840103	1	Coupling 1 1/2" PVC
59	840104	1	Filter Assembly/Vac Motor

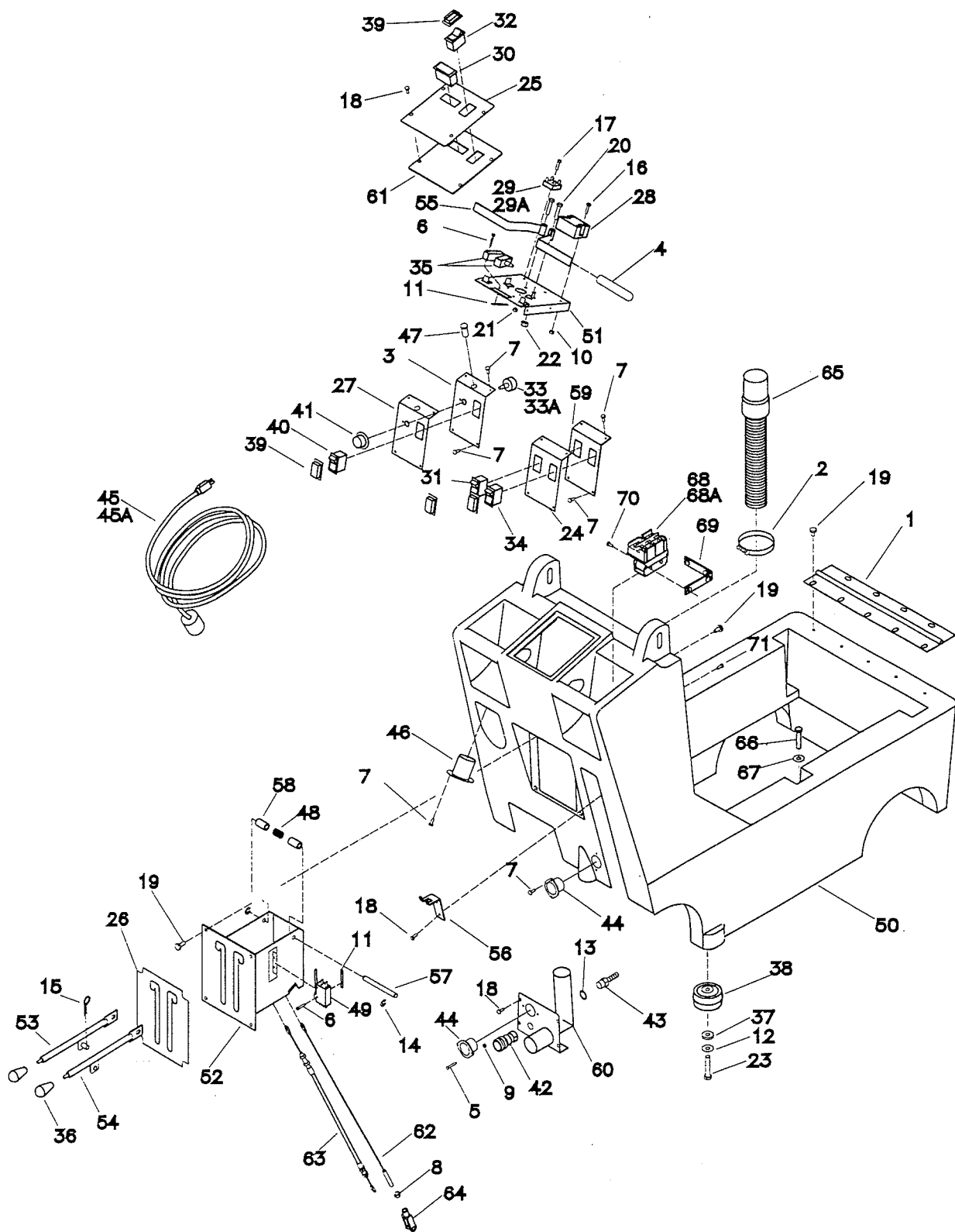

# PARTS LIST

Item	Part No.	Qty	Description	Item	Part No.	Qty	Description
1	260087	1	Hinge 15"	36	760592	2	Knob Oval Tapered
2	260203	1	Hose Clamp 102120 Murray	37	762295	2	Bushing .37 x .62 x .19
3	260255	1	Speed Control Bracket 260B	38	762331	2	Wheel, 2.5 D x 1.28 W x .38 ID
4	260291	2	Handle Grip 260 TD	39	802657	4	Silicone Boot/Carling SW
5	710204	2	SCR-MC 6-32 x .50 ST PL	40	809754	1	Switch Rocker
6	710307	6	SCR-MC 6-32 x 1.00 ST PL	41	809874	1	Knob Speed Control
7	711160	12	SCR-Hi/Lo #10 x 5/8 PL	42	828370	1	BH2-60 Female Coupler
8	711322	1	Nut-Hex 5/16-24 ST PL	43	828952	1	3/8 BARB x 1/4 MPT
9	711371	2	Nut-Nyloc 6-32	44	829851	2	Flanged Twst Loc FM Midget
10	711372	2	Nut-Nyloc 8-32	45	830292	1	Cord Assembly 14/3 75'
11	711430	3	Nut-Tinnerman 6-32	45A	740477	1	Cord Assembly, International
12	711523	2	WSR-Wave .37 x .68 x .08	46	830540	1	Flange Male Recpt15 A 125
13	711578	1	WSR-Flat 1/2 BR	47	832859-1	1	Indicator Light 115V Assembly
14	711717	2	Retaining Ring-E Ext	47A	832860-1	1	Indicator Light 240V Assembly
15	711808	2	Cotter Pin-Hair #13	48	833102	1	Spring .62 x .75 x 1.75
16	712516	2	SCR-SC 8-32 x .62 SS	49	833329	1	Actuator Switch
17	712537	6	SCR-MC 10-24 x .75 SS	50	840005	1	Base Tank ACS 20
18	712540	10	SCR-MC 10-24 x .37 SS TH	51	840013	1	Plate Lever Switch
19	712560	13	SCR-MCH 1/4-20 x .50 SS Nylon	52	840014	1	Lever Control Box
66	712566	6	SCR-MC 1/4-20 x 1.25 SS	53	840022	1	Lever Bar Assembly Belt Tension
20	712569	2	SCR-MC1/4-20 x 1.50 SS	54	840023	1	Lever Bar Assembly Vac Shoe
21	712638	2	Nut-Hex 10/24 SS Nyloc	55	840024	2	Lever - Switch
22	712665	2	Nut-Hex 1/4-20 SS	56	840027	1	Hose Clip
67	712759	6	WSR-Flat .31 x 1.37 x .06 SS	57	840039	1	Lever Pivot Pin
23	713048	2	BLT-HH 3/8/16 x 2 1/2 #5	58	840040	2	Bushing, Lever Box
24	715621	1	Decal Vac, Pump	59	840057	1	Plate, Switch
25	715622	1	Decal Dash ACS 20	60	840079	1	Auxiliary Plate Assembly
26	715623	1	Decal Track, Brush Lift	61	840080	1	Dash Pannel
27	715626	1	Decal Speed Control ACS	62	840091	1	Cable Lift ACS
28	740187	1	Controller 2 Speed 115/230V	63	840092	1	Cable Tension ACS
29	740202	2	Rect. Bridge 50A 600V IMP	64	840093	1	Yoke ACS
29A	740203	2	Rect. Bridge 50A 1000V	65	840097	1	Hose Grey, Water
30	740229	1	Gauge BR Pressure 0-1.5	66	712566	6	SCR-MC 1/4-20 x 1.25 SS
31	740736	1	Switch ACS Pump	67	712761	6	WSR-Flat .25 x 1.50 SS
32	740736	1	Switch Fwd/Rev/Pump ACS	68	742145	1	Relay, Motor Reversing 120V
33	740738	1	Pot Assembly 250 K	68A	742146	1	Relay, Motor Reversing 240V
33A	740787	1	Pot Assembly ACS 240 Vac	69	840108	1	Bracket, Relay
34	740801	1	Switch TIGL51-6S-WH-NBL	70	712811	2	SCR-MC 10-24 x .50
35	740806	2	Switch Snap Act 20A1HP	71	712813	2	SCR-MC 10-24 x .75

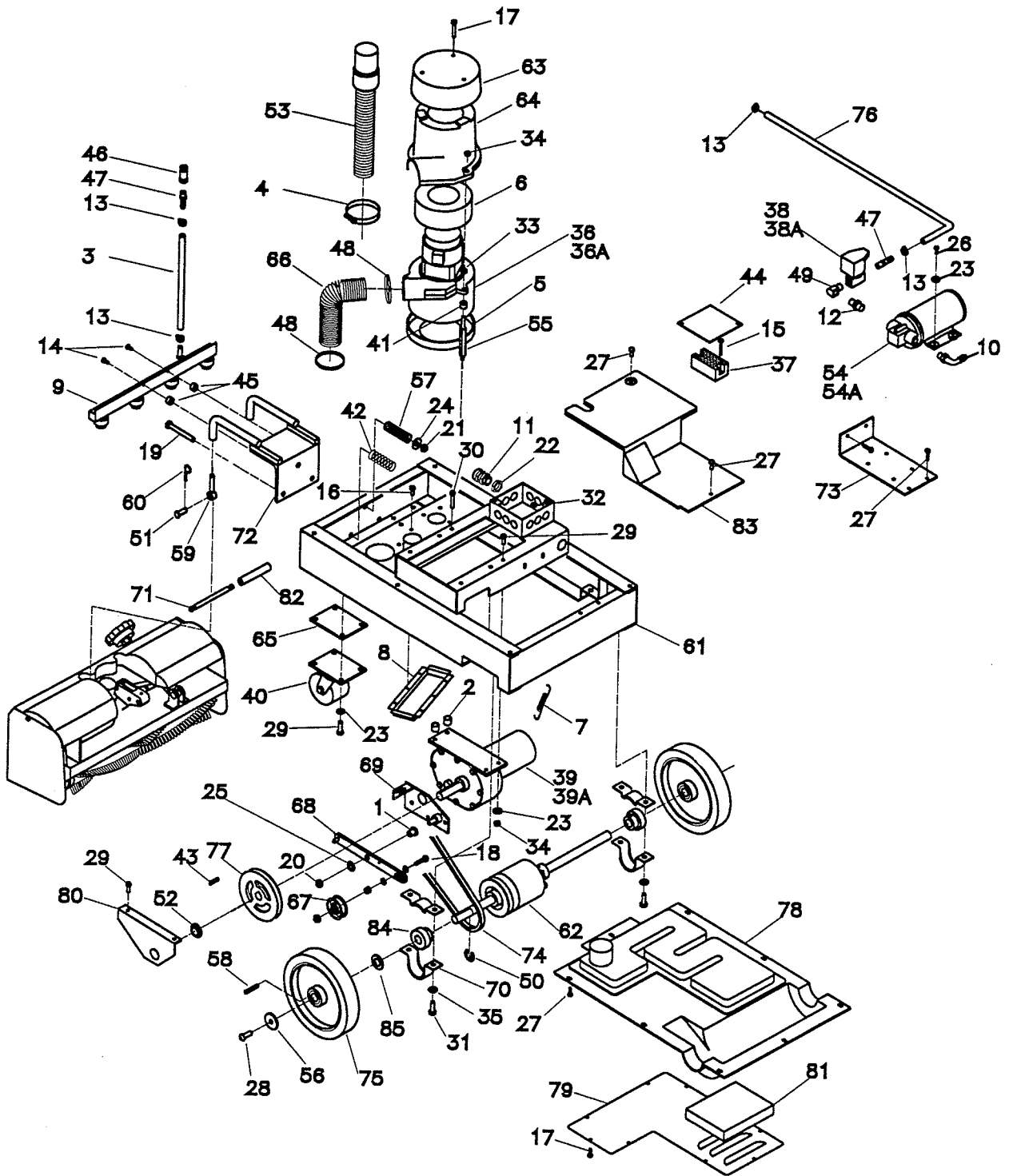

## Parts List

Item	Part No.	Qty.	Description	Item	Part No.	Qty.	Description
1	260066	1	Oilite Flange Bushing	43	762375	1	Key, .187 sq. x .78
2	260141	2	Spacer, Lift Arm	44	805634	1	Cover Box (741012)
3	260182	1	Solution Hose 18"	45	809880	2	Bushing
4	260203	1	Hose Clamp	46	828368	1	BH2-61 Male Coupler
5	290017	1	Moulded Vac Motor Gasket	47	828952	2	3/8 Barb x 1/4 MPT
6	380064	1	Ring, Foam	48	829067	2	Crimp Clamp 560R
7	430051	1	Return Spring	49	831306	1	Fitting Brass 90 1/4 MPT
8	450004	1	Air Manifold	50	809148	2	E-Ring .75
9	450023	1	Spray Tube Assembly 4 Jet	51	831965	2	Clevis Pin 3/8 x 1.63
10	450040	1	Elbow PLT 3/8 MPT x 3/8 Barb	52	832554MCH	1	Flange, Bushing Machined
11	450050	3	Heyco Bushing Liquid Tight	53	832790	1	Hose, Vac Tank
12	450059	1	Fitting Brass 1/4 MPT x 1/4 MPT	54	833067	1	Pump 100 PSI 115V
13	450076	4	Crimp Clamp SS 185R	54A	833068	1	Pump 100 PSI 230V
14	712545	2	SCR-MC 10-32 x .875 SS	55	833265PLT	3	Threaded Spacer PLT Zinc
15	710307	2	SCR-MC 6-32 x 1.00 ST PL	56	809226	2	WSR-Flat .40 x 1.50 x .12
16	711124	6	SCR-ST-B 10 x .37 NI	57	833302	1	Die Spring
17	711160	19	SCR-Hi/Lo #10 x 5/8 PL	58	361233	2	Key 3/16 sq. x 1 1/2
18	711210	1	BLT-HH 1/4-20 x 1.25 STPL	59	833341-1	2	Eye Bolt 3/8-16 x 2 5/8
19	711280	3	BLT-HH 3/8-16 x 3.5 STPL	60	833374	2	Hairpin Cotter 3/8
20	711375	1	Nut-Nyloc 3/8-16 1/2 Nut	61	840006	1	Frame Weldment ACS 20
21	711380	3	Nut-Nyloc 3/8-16	62	840115	1	Differential, ACS Keyed
22	711400	3	Nut-Pipe	63	840011	1	Vac Motor Cover Top
23	711504	18	WSR-Flat 1/4 ID SS	64	840012	1	Vac Motor Cover Bottom
24	711515	6	WSR-Flat .406 x .812 x .062	65	840018	2	Washer Plate
25	712312	2	WSR .187 x 1.25	66	840042	1	Hose Vac Motor Output
26	712537	4	SCR-MC 10-24 x .75 SS	67	840044	1	Pulley, Idler
27	712540	12	SCR-MC 10-24 x .37 SS TH	68	840046	1	Tension Arm Assembly
28	710986	2	SCR-SC 3/8-16 x 1.00 ST PL	69	840048	1	Tension Plate Assembly
29	712562	12	BLT-HH 1/4-20 x .75 SS	70	840049	2	Stamped Steel Pillow Block
30	712566	2	SCR-MC 1/4-20 x 1.25 SS	71	840053	1	Pin, Vac Shoe Lift
31	712575	4	BLT-HH 5/16-18 x .75 SS	72	840060	1	Brush Mount Assembly
32	712605	2	Nut-Hex 6-32 SS	73	840064	1	Bracket, Pump Motor
33	712665	3	Nut-Hex 1/4-20 SS	74	840066	1	Belt, Drive
34	712667	9	Nut-Hex 1/4-20 SS Nyloc	75	840116	2	Wheel 8 x 1.5 x .75
35	712767	4	WSR-Flat .406 x .75 SS	76	840083	1	Hose 3/8 ID x 31.0
36	740089	1	Vac Motor 120V	77	840088	1	Pulley ACS Drive
36A	740230	1	Vac Motor 240V	78	840089	1	Baffle Exhaust ACS
37	740189	1	Terminal Block 10471	79	840090	1	Cover Exhaust Baffle
38	740245	1	Water Solenoid 115V	80	840094	1	Brace Shaft Bushing
38A	740240	1	Water Solenoid 240V	81	840096	1	Filter Exhaust Baffle
39	740732	1	Gear Motor 120V AC	82	840098	1	Hose Vac Shoe Spacer
39A	740786	1	Gear Motor 240V AC	83	840105	1	Cover, Drive Motor
40	760251	2	Caster 3" x 2	84	881059	2	Bearing .75 ID w/Collar
41	762073	3	Bushing .259 x .375 x .265	85	711512	2	WSR-Flat .75 x 1.37 x .08
42	762339	2	Spring, Compression				

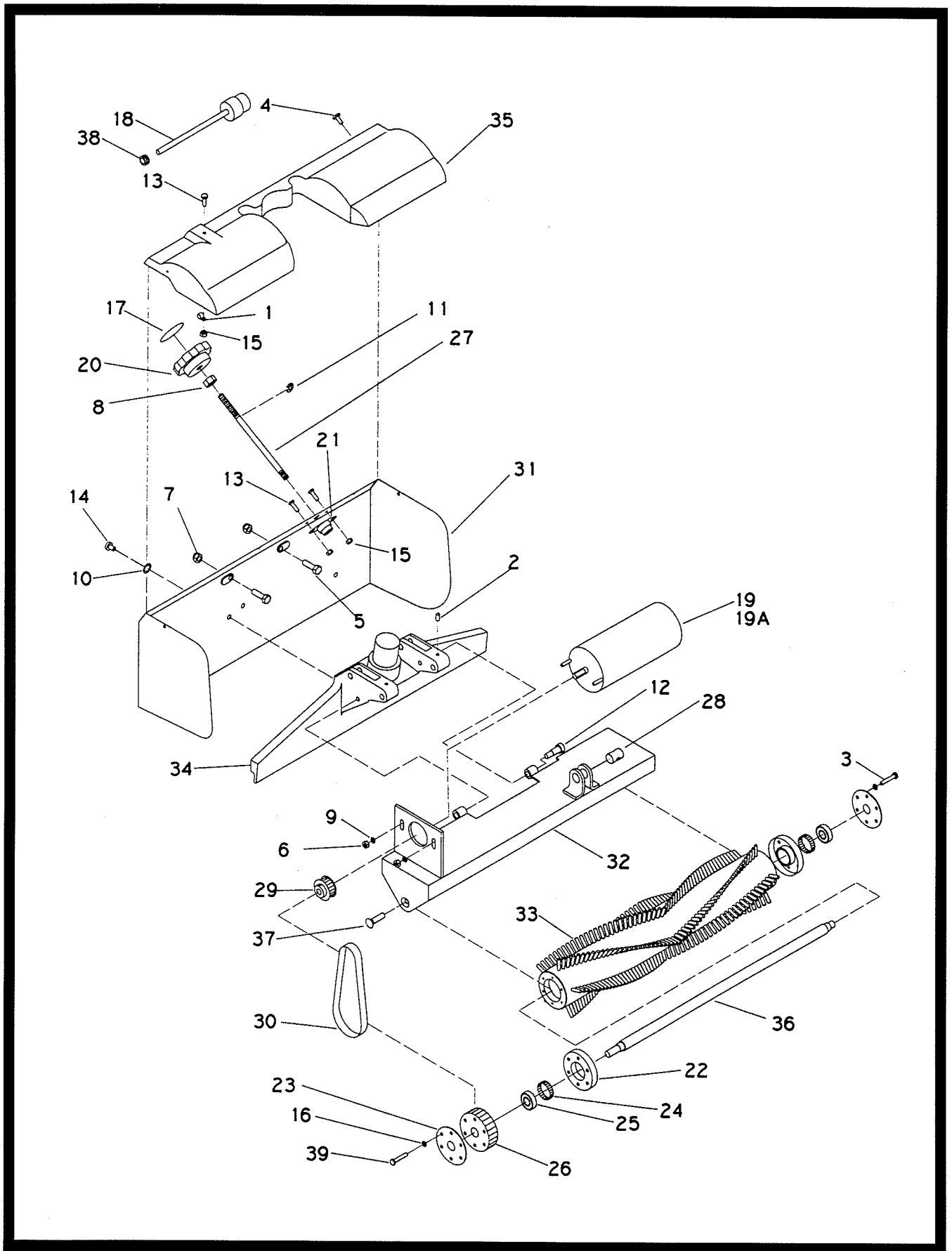

# PARTS LIST

Item	Part No.	Qty	Description
1	250039	1	Clamp Plastic 5/16 3305
2	711018	2	SCR-SK 10-32 x .37
3	711126	6	SCR-ST-B 10 x .75
4	711160	5	SCR-Hi/Lo #10 x 5/8 PL
5	711231	2	BLT-HH 5/16 - 18 x 1.25
6	711350	2	Nut-Nyloc 10-32
7	711353	2	Nut-Acorn 5/16-18 ST PL
8	711391	1	Nut-Hex Jam 3/8-16 ST PL
9	711504	2	WSR-Flat 1/4 ID SS
10	711554	10	WSR-Internal Lock 1/4 ID
11	711717	1	Retaining Ring - E Ext .37
12	712081	2	BLT-SDR 5/16 /18 x .75 x .375
13	712536	3	SCR-MC 10-24 x .62 SS
14	712560	10	SCR-MCH 1/4-20 x .50 SS Nyloc
15	712638	3	Nut-Hex 10/24 SS Nyloc
16	712757	12	WSR-Helical #10 SS
17	715090	1	Decal Brush Pressure ACS
18	740739	1	Power Cord ACS Brush
19	740740	1	Motor Brush ACS 120 Vac
19A	740785	1	Motor Brush ACS 240 Vac
20	760034	1	Knob, Adj 3/8 x 16 Thread
21	760035	1	Bearing, Flanged Mounted
22	827894	2	Cup Bearing
23	827896	2	Cover Bearing
24	828145	2	Ring Retaining
25	828588	2	Bearing 747
26	832903	1	BR Pulley 3-4 OGR 5MM
27	833281	1	Threaded Rod Adj SS
28	833342	1	Shaft Pivot SS
29	833357	1	Pulley Motor 20 Tooth 5MM
30	833376	1	Belt HTD 375-5M-09
31	840007	1	Vac Shoe Plate ACS 20"
32	840019	1	Brush Bracket ACS 20"
33	840052	1	Brush ACS 20
34	840062	1	Vac Shoe 20" ACS
35	840065	1	Cover-Brush Splash
36	840081	1	Axle ACS 20"
37	710923	2	SCR-SC 5/16-18 x .62 ST PL
38	700287	1	Grommet
39	712066	6	SCR-ST-AB PH 10 x 1.25 PL

# TROUBLE SHOOTING GUIDE

Use this guide to pinpoint problem areas that may arise with use of your ACS machine. **CAUTION!** Unplug supply cord and disconnect batteries before servicing machine components.

## SOLUTION SYSTEM

- I. No water dispensed from spray jets.
  - A. The hose connection at the pump for the spray tube may not be tight. Disconnect, reconnect the fitting so they snap together securely.
  - B. The solution pump diaphragm may be damaged. Inspect by removing the pump from the pump and inspect the diaphragm for cracks. Replace if required.
- II. Spray intermittent or streaked.
  - A. Solution hoses may be pinched or kinked. Replace kinked hoses if found.
  - B. The filter strainer in the solution tank may be clogged. Clean the strainer thoroughly.
  - C. The spray jets may be clogged. Remove the end plug from the spray tube and flush by turning the pump on. Remove the spray jets from the tube and clean as required. Do not clean out the hole in the jet with a pin or wire. This may cause damage to the jet causing permanent streaking.

## SOLUTION RECOVERY SYSTEM

- I. Solution recovery is reduced.
  - A. Vacuum filter may be clogged. First check filter in recovery tank. Clean if required.
  - B. Check vacuum hoses for secure fit over the vacuum fittings. Tighten clamps where used. Also check hoses for cracks, kinks or clogging.
  - C. Check the seals on the tank covers for damage. Replace if needed. Make sure cover closes freely without restrictions.
  - D. Make sure the drain hose on the back of the tank is sealed.
  - E. Check the vacuum slot on the scrub head for clogging. Clean out slot if required.
  - F. Vacuum motor brushes could be worn. Inspect and replace. If the motor has run through two sets of brushes, replace the motor.

## **SOLUTION SYSTEM**

- II. Pump motor does not run.
  - A. Check pressure switch for short circuit. By-pass the pressure switch by connecting the two black leads to the switch to one another. If the motor then runs, replace the pressure switch.
- III. Machine fails to run when handle switch is activated.
  - A. Speed control may be shorted out.
  - B. Speed control potentiometer may be defective.

## **ELECTRICAL SYSTEM A.C.**

- I. Vacuum motor does not start.
  - A. Inspect the micro switch lever inside the electrical enclosure to make sure it is functioning properly. As the scrub head is lowered the lever should activate the switch. Bend the switch lever to adjust function if required.
  - B. Check motor carbon brush.
  - C. Check plugs on power cord.

For all the above make sure all the electrical connections are secure. Make sure the cord to the wall outlet is secure.

## LIMITED WARRANTY

Minuteman International, Inc. warrants to the original purchaser/user that this product is free from defects in workmanship and materials under normal use and service for a period of three years from date of purchase. In addition, Minuteman International, Inc. will, at its option, honor labor warranty claims for the first 12 months from date of sale, provided such claims are submitted through and approved by factory authorized repair stations. Minuteman International, Inc. will, at its option, repair or replace without charge, except for transportation costs, parts that fail under normal use and service when operated and maintained in accordance with the applicable operation and instruction manuals.

This warranty does not apply to normal wear, or to items whose life is dependent on their use and care, such as belts, cords, switches, hoses, rubber parts, electrical motor components or adjustments. Parts not manufactured by Minuteman International, Inc. such as engines, batteries, battery chargers, hydraulic pumps, and tires are covered by and subject to the warranties and/or guarantees of their manufacturers. Please contact Minuteman International, Inc. for procedures in warranty claims against these manufacturers.

**Special warning to purchaser** -- Use of replacement filters and/or prefilters not manufactured by Minuteman International, Inc. or its designated licensees, will void all warranties expressed or implied.

A potential health hazard exists without exact original equipment replacement.

All warranted items become the sole property of Minuteman International, Inc. or its original manufacturer, whichever the case may be.

Minuteman International, Inc. disclaims any implied warranty, including the warranty of merchantability and the warranty of fitness for a particular purpose. Minuteman International, Inc. assumes no responsibility for any special, incidental or consequential damages.

This limited warranty is applicable only in the U.S.A. and Canada, and is extended only to the original user/purchaser of this product. Customers outside the U.S.A. and Canada should contact their local distributor for export warranty policies. Minuteman International, Inc. is not responsible for costs or repairs performed by persons other than those specifically authorized by Minuteman International, Inc. This warranty does not apply to damage from transportation, alterations by unauthorized persons, misuse or abuse of the equipment, use of non-compatible chemicals, or damage to property, or loss of income due to malfunctions of the product.

If a difficulty develops with this machine, you should contact the dealer from whom it was purchased.

This warranty gives you specific legal rights, and you may have other rights which vary from state to state. Some states do not allow the exclusion or limitation of special, incidental or consequential damages, or limitations on how long an implied warranty lasts, so the above exclusions and limitations may not apply to you.

# **Minuteman<sup>®</sup>**

**World Headquarters**  
Minuteman International, Inc.  
111 South Rohlwing Road  
Addison, Illinois 60101

(630) 627-6900  
FAX (630) 627-1130

Minuteman Canada, Inc.  
2210 Drew Road  
Mississauga, Ontario  
L5S 1B1

(905) 673-3222  
FAX (905) 673-5161

988382

Printed in U.S.A.