



Electronic Service Manuals

This electronic document is provided as a service to our customers. We do not create the contents of the information contained in this document. Should you have detailed questions pertaining to the information contained in this document, you may contact Michco, or the manufacturer which provided the original information in this electronic deliverable. Michco's only part in this electronic deliverable was the electronic assembly process. By providing this manual on line we are not guaranteeing parts availability.

You may contact Michco through the following methods:

Phone (517) 484-9312 or (800) 331-3339

2011 N. High St. -- Lansing, Michigan -- 48906

Fax: (517) 484-9836

Email: CustServe@Michco.com

Web site: www.Michco.Com

Parts Web site: www.FloorMachineParts.Com

Order Parts on Line at:

www.FloorMachineParts.Com

Directly to Parts & Service:

By Email: **Shop@Michco.com**

By Fax: (517) 702-2041

By Voice: Use numbers above.

Serving the Cleaning Industry Since 1922

Notice: All copyrighted material remains property of original owners, all trademarks are property of respective owners. Manuals are subject to Manufacturer's reproduction limitations. Originals or reproductions were provided by manufacturers through a request. We make no warranty as to the correctness of information provided in this document and you assume all risk. By placing these manuals on line we are not declaring our corporation to be an manufacturer authorized dealer or provider, please check our web site for authorized manufacturers we represent.

Minuteman[®]
Excellence Meets Clean



Parts and Instruction Manual
ES 2832 Walk-Behind Scrubber

ES2832, ES2832HD, ES2832DNA and ES2832DNA-BJ models only

This manual is furnished with each new **MINUTEMAN ES™ 2832**. This provides the necessary operating and preventive maintenance instructions. Operators must read and understand this manual before operating or servicing this machine.

This machine was designed to give you excellent performance and efficiency. For best results and minimal cost, please follow the general guidelines below:

- Operate the machine with reasonable care.
- Follow the manufacturers suggested maintenance instructions as provided in this booklet.
- Use original Minuteman supplied parts.

TECHNICAL SPECIFICATIONS

Model	ES™ 2832
Model No.	ES28CQP / ES28DQP / ES32CQP / ES32DQP ES28C / ES28D / ES32C / ES32D / ES28CQPIW ES28DQPIW / ES32CQPIW / ES32DQPIW
Current	70 Amps
Voltage, Batteries	36 volts, 6-6volt
Battery Capacity	275 AH
Sound Level	72dB
Dimensions (LxWxH)	66" x 44" x 47" (167.64cm x 111.76cm x 119.38cm)
Gross Weight	1,020 lbs (462.66 kg) with batteries 614 lbs (278.51 kg) without batteries
Working Grade Transport	16% (10°)
Working Grade Cleaning	10% (7°)
Inflate Wheel Pressure to	50 PSI (Front Wheel)

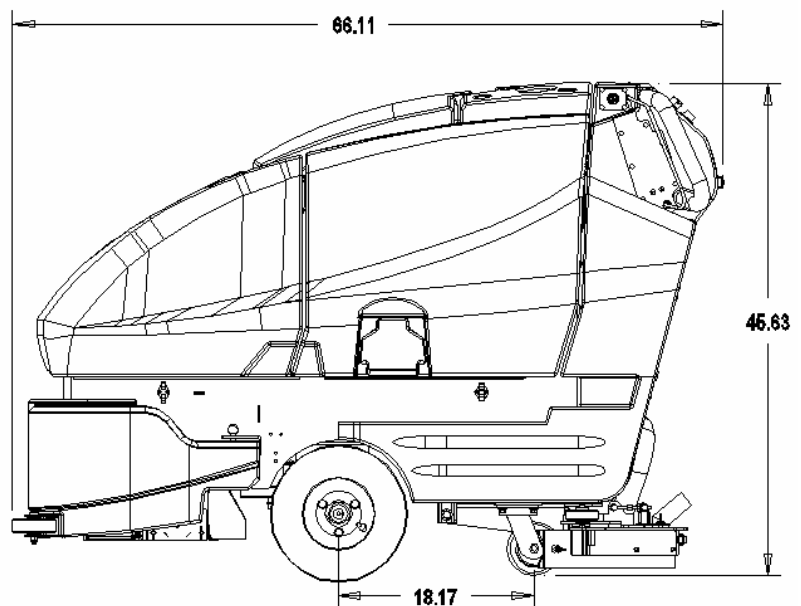
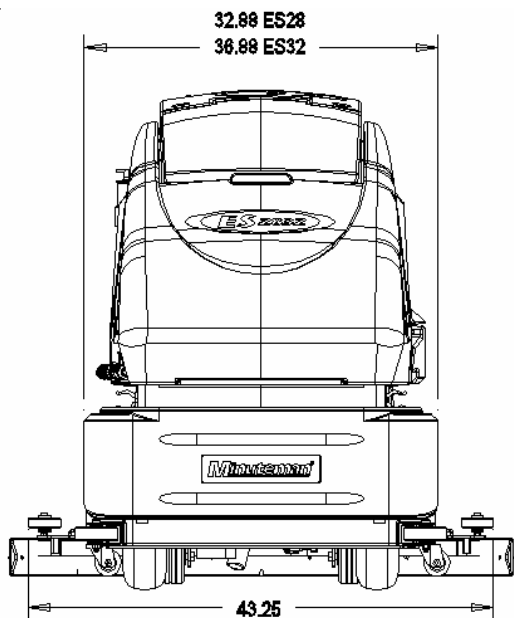

EC Declaration of Conformity

according to Directives 98/37/EC, 89/336/EEC and 72/23/EEC

We, Minuteman International Incorporated, of 111 South Rohlwing Road Addison Illinois 60101 USA, declare under our sole responsibility that the product ES28C, ES32C, ES28D, ES32D, ES2832, ES28CPQ, ES32CPQ, ES28DPQ, ES32DPQ, ES28CPQIW, ES32CPQIW, ES28DPQIW, ES32DPQIW Automatic Floor Scrubbing machines to which this declaration relates corresponds to the relevant requirements of the EC Directives 98/37/EC, 89/336/EEC and 72/23/EEC. The following standards were used to determine compliance with the Directives: EN 292, EN 60335-2-72, EN 953, EN 55022:1998 AND EN 60335-1:2002.

SOUND		VIBRATION						
72 dB Operator	69 dB At 3m	1.9 m/s² At Operators Hand Grips						
Tests were conducted on 3/14/04 with calibrated sound and vibration equipment under the conditions noted below: <table style="width: 100%; margin-top: 10px;"> <tr> <td style="width: 50%;">General Condition: Cloudy</td> <td style="width: 50%;">Wind: 0 km/hr</td> </tr> <tr> <td>Temperature: 29⁰C</td> <td>Humidity: 85%</td> </tr> <tr> <td>Barometric Pressure: 29.5</td> <td></td> </tr> </table>			General Condition: Cloudy	Wind: 0 km/hr	Temperature: 29 ⁰ C	Humidity: 85%	Barometric Pressure: 29.5	
General Condition: Cloudy	Wind: 0 km/hr							
Temperature: 29 ⁰ C	Humidity: 85%							
Barometric Pressure: 29.5								

Jeff Pollack

4/20/04

Jeff Pollack, Standards Engineer

Date

*Form: EC065 Rev**

Table of Contents

Important Safety Instructions	1
For Safety During Operation	1
For Safety When Servicing or Maintaining Machine	1
Inspection & Unpacking	2
Electrical	2
Batteries	2
Operator Responsibility	2
Machine Components	2
Front	2
Rear	3
Control Console	3
The Control Console	4
Accelerator Lever	4
Speed Control	4
Directional Switch	4
Directional Indicator	4
Key switch	4
Emergency Belly Bar	4
Off-aisle wand switch	4
Battery Gauge	4
Solution Control	4
Mode Selector	4
Cleaning Modes	5
Regular Scrub Mode	5
Heavy Scrub Mode	5
Double Scrub Mode	5
Vacuum Only Mode	6
Transport Mode	6
Water Flow	6
Speed Control	6
Operation of Controls	7
Power Save Mode	7
Emergency Disconnect Handle	7
Circuit Breaker	7
Battery Compartment	7
Scrub Deck	8
Cylindrical Scrub Deck	8
Disc Scrub Deck	9
Scrub Deck Installation	9
Installation Instructions	10

Rear Squeegee	11
Rear Squeegee Components	11
Rear Squeegee Adjustment	12
Off Aisle Wand	13
Off Aisle Wand Tool	13
The ES2832	14
Machine Operation	14
After Use	15
Maintenance Schedule	16
Lubricating the Machine	16
General Machine Troubleshooting	17
ES2832 Fault / Diagnostic Codes	18
Exploded Views	20
Main Assembly - Disc Scrub Decks / Brushes	20
Main Assembly - Cylindrical Scrub Decks / Brushes	21
Base Assembly	22
Base Assembly BOM	23
Drive Assembly	24
Drive Assembly BOM	25
Squeegee Lift Mechanism	26
Pump Assembly	27
In-Line Filter Assembly	28
Solenoid Assembly	28
Linkage Assembly	29
Linkage Assembly BOM	30
Control Console Assembly	31
Control Console Assembly BOM	32
Control Bracket Assembly	33
Electric Box Assembly	34
Dashboard Assembly	34
Solution Tank Assembly	35
Recovery Tank Assembly	36
Recovery Tank Assembly BOM	37
Fixed Lid Assembly	38
28" Cylindrical Scrub Deck Assembly	39
28" Cylindrical Scrub Deck Assembly BOM	40
32" Cylindrical Scrub Deck Assembly	41
32" Cylindrical Scrub Deck Assembly BOM	42
28" Disc Scrub Deck Assembly	43
28" Disc Scrub Deck Assembly BOM	44
32" Disc Scrub Deck Assembly	45
32" Disc Scrub Deck Assembly BOM	46

Bumper Cover Assembly - 28"	47
Bumper Cover Assembly - 32"	48
Rear Squeegee Assembly	49
Rear Squeegee Assembly BOM	50
Off Aisle Wand Assembly (Optional)	51
Off Aisle Wand Assembly BOM	52
Off Aisle Wand Kit	53
Wiring Diagrams	54
Minuteman International Made Simple Commercial Limited Warranty	59

Important Safety Instructions

Operators must read and understand this manual before operating or maintaining this machine.

Do not operate this machine in flammable or explosive areas.

This machine is designed solely for scrubbing dirt and dust in an indoor environment.

Minuteman does not recommend using this machine in any other capacity.

The following information below may cause a potential hazard to the operator and equipment. Read this manual carefully and be aware when these conditions can exist. Take necessary steps to locate all safety devices on the machine and train the personnel operating the machine. Report any machine damage or faulty operation immediately. **Do not use machine if it is not in proper operating condition.**

For Safety During Operation

Keep hands and feet clear of moving parts while machine is in operation.

Make sure all safety devices are in place and operate properly. All covers, doors and latches must be closed and fastened before use.

During operation, attention should be paid to other persons in the work area and especially if small children are present.

Electric motors and components can cause an explosion when operated near explosive materials or vapor. Do not operate this machine near flammable materials such as solvents, thinners, fuels, grain dust, etc.

Store or park this machine on a level surface only, with parking brake engaged. To prevent unauthorized use, machine should be stored or parked with the key removed.

This machine is designed for level operation only. **Do not operate on ramps or inclines.**

This machine is not suitable for picking up hazardous dusts.

Use caution when moving this machine into areas that are below freezing temperatures. Any water in the tanks or hoses can cause damage to the machine.

For Safety When Servicing or Maintaining Machine

Stop on level surface.

Disconnect the power to the machine by pulling the large red handle (Anderson Plug) located in the back of the machine, mid-right, when charging batteries or during installation or removal of brushes.

Avoid moving parts. Do not wear loose jackets, shirts, or sleeves when working on machine. Avoid contact with battery acid. Battery acid can cause burns. When working on or around batteries, wear protective clothing and safety glasses. Remove metal jewelry. Do not lay tools or metal objects on top of batteries.

Charging batteries generates explosive gasses. **Do not charge batteries when open flames or sparks are present. Do not smoke.** Make sure the charger is turned off before disconnecting it from the machine.

Charge the batteries in a well-ventilated area with the battery cover removed completely.

Do not clean machine with a pressure washer.

Authorized personnel must perform repairs and maintenance. Use Minuteman supplied replacement parts.

SAVE THESE INSTRUCTIONS

Inspection & Unpacking

Carefully unpack and inspect your **ES Walk-Behind Scrubber** for shipping damage. Follow unpacking instructions on shipping pallet. Each unit has been tested and thoroughly inspected before shipment. Any damage is the responsibility of the delivery carrier who should be notified immediately.

Electrical

This machine is battery operated and designed to operate on 36 volts DC (6) 6-volt batteries.

Batteries

The recommended batteries are rated 275Ah (Minuteman P/N 956740).

We do not recommend mixing AMP hour capacities. Any alternate battery sets can be used if they equal physical size and capacity. See page 13 for service and installation.

Operator Responsibility

Read this manual carefully before operating this machine.

The operator is responsible in taking care of the daily maintenance and check ups of the machine to keep it in good working condition. The operator must inform the service mechanic or supervisor when the scheduled maintenance intervals are required as stated in the MAINTENANCE section of this manual.

Before starting familiarize yourself with the machine and its controls (see “Machine Overview, Front”, “Machine Overview, Rear”, “Operator Compartment”, “Control Console” diagrams).

Machine Components - Front

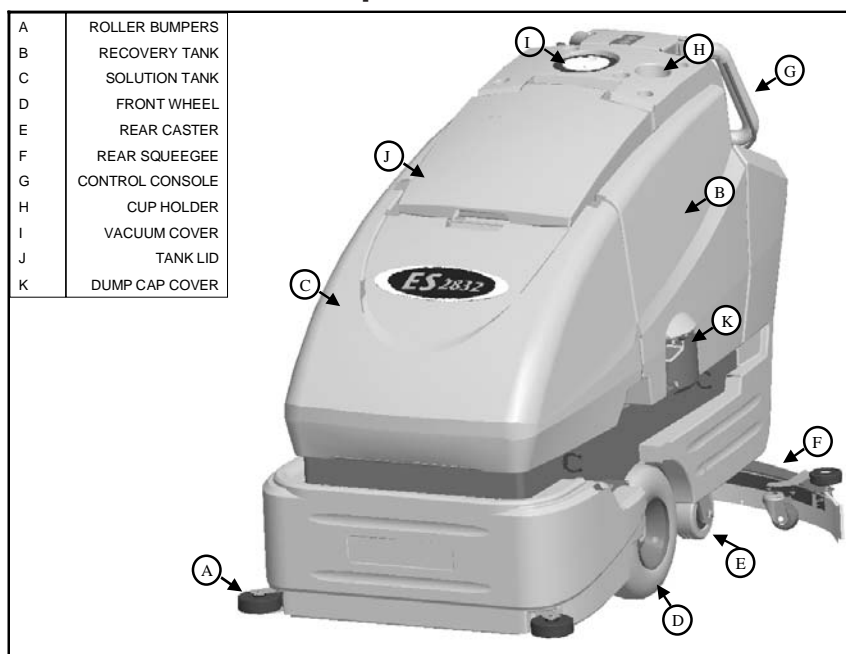

Machine Components - Rear

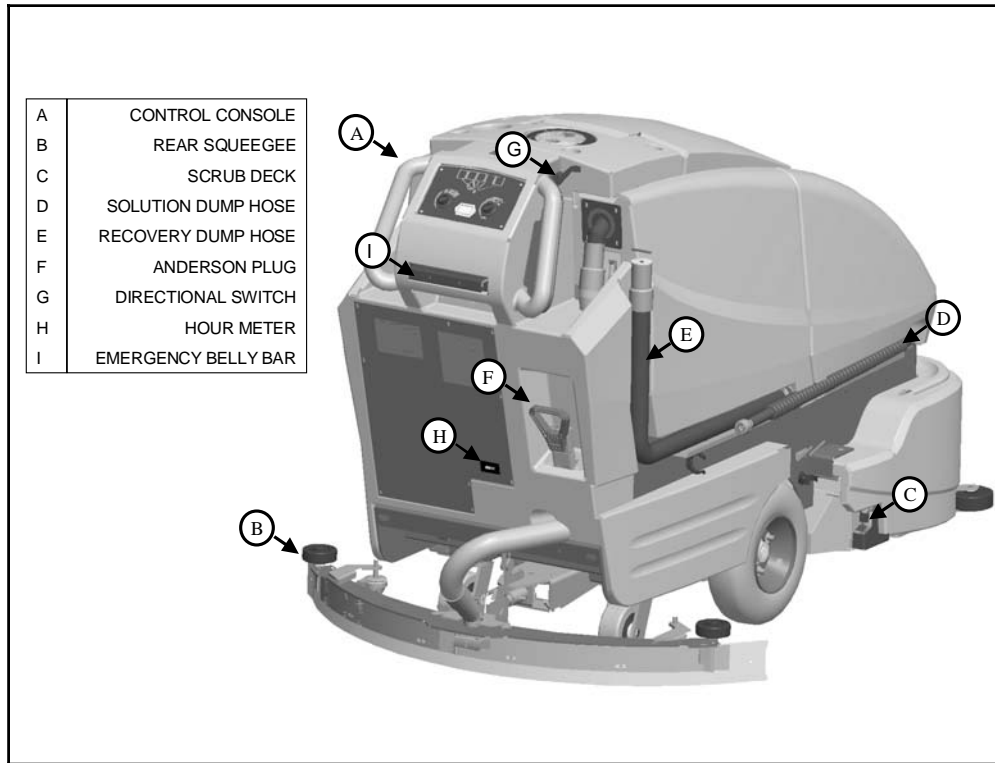

Machine Components - Control Console

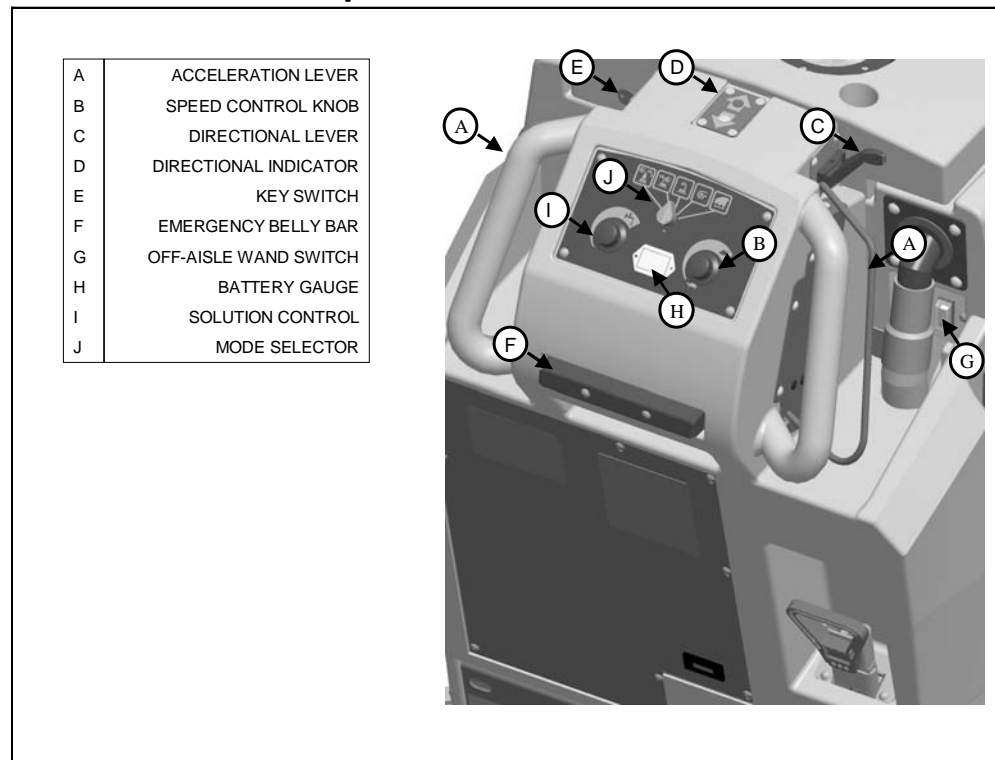

The Control Console

For operator ergonomics, the control console houses all the primary function buttons are grouped in a central area. The key switch, main keyboard, directional switch and off-aisle wand switch are clustered in the back area. The directional switch (forward and reverse) is located in front of the console for easy fingertip operation.

Accelerator Lever

(A) Enables the machine to move forward or backwards once depressed.

Speed Control

(B) This knob controls the rate at which the machine moves. Turning the knob clockwise will increase the speed. Turning the knob counter-clockwise will decrease the machine speed.

Directional Switch

(C) When you flip the switch down, the machine moves backwards or flip the switch upward, the machine will go forward.

Directional Indicator

(D) This indicator displays which direction the ES 2832 will travel once the Accelerator Lever is depressed. A light is available for each direction. Amber when set to forward. Red when set to reverse.

Key switch

(E) Controls the machine's power (On/Off) with a key for safety. All operational settings are retained even when the power is turned off and on. This also serves as a reset switch when error or fault codes.

Emergency Belly Bar

(F) If this bar is to be depressed it will override the directional switch and force the ES 2832 to go forward. Most useful if backed into a corner or object to prevent from pinching the operator.

Off-aisle wand switch

(G) On/Off control for the water supply to the wand and vacuum motor. If the switch is in the On position it will force the battery gauge to blink 6 LEDs to signify the wand is currently on.

Battery Gauge

(H) This gauge displays the remaining battery life. The gauge has a readout of 10 LEDs. 3 Green, 4 Amber, 3 Red. This gauge will also display the fault code if the system has an error represented by the number illuminated flashing LEDs. *See Fault/Diagnostics Codes below for specific code.*

If the battery life is low the battery gauge bar icon will be flashing to signal the operator that the machine is almost out of power. Once this signal is displayed to the operator, all functions will shut off including the transport mode. The operator has to turn the *key switch OFF and then, ON* to reset the machine. The machine then will only have a few minutes left of reserve power for a short *Vacuum only mode* to pick up remaining solution on the floor and *Transport* power.

Solution Control

(I) This knob controls the rate at which solution is put down. Turning the knob clockwise will increase the amount of solution put down. Turning the knob counter-clockwise will decrease the solution rate. The knob can be adjusted between **0.25** gpm up to **1.1** gpm.

Mode Selector

(J) This switch will toggle between one of the five cleaning modes available on the ES 2832.

Cleaning Modes

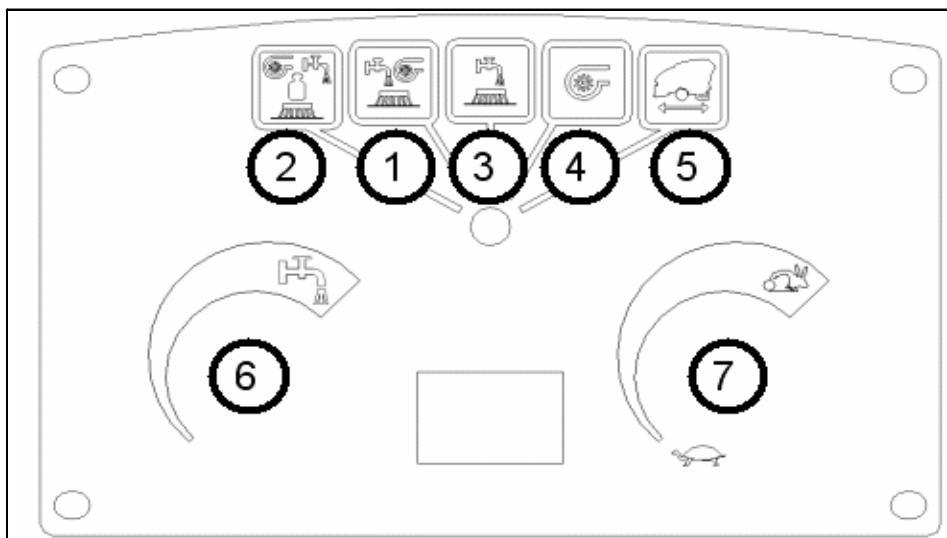

1. Regular Scrub Mode

When the machine is running in this mode, the machine will perform all operations. This mode can be used for day-to-day tasks under normal conditions. When the operator sets

the *directional switch* to *forward* and activates the *accelerator handle*, the solution pump will turn on, the brushes will turn on and be lowered to the floor, as well as the rear squeegee. While operating in this mode, the solution will be dispersed into the brushes, which will scrub the floor allowing the chemical in the solution to break down the dirt on the floor. As the machine continues to move forward, the rear squeegee and vacuum system will recover the dirt and dispensed solution. If the operator stops moving, the machine will automatically raise the scrub deck and turn off the brushes. If the *directional switch* is changed to reverse the machine will continue to operate normally, only the rear squeegee will raise up.

2. Heavy Scrub Mode

This mode is similar to *Regular Scrub*. The machine will continue to operate the same as if it was in *Regular Scrub Mode*, only this mode applies more solution and brush pressure is increased. This mode is used for high traffic areas and areas that have been heavily soiled, but do not require time for the solution to soak.

3. Double Scrub Mode

When the machine is running in this mode, the machine will perform all operations except dirty solution recovery. This mode can be used if the floor is heavily soiled and the chemical will need additional time to emulsify grease and oils that are on the floor. When the operator sets the *directional switch* to either the *forward* or *reverse* position and activates the *accelerator lever*, the solution pump will turn on, the brushes will turn on and be lowered to the floor. While operating in this mode, the solution will be dispersed into the brushes, which will scrub the floor allowing the chemical in the solution to break down the dirt on the floor. As the machine continues to move forward or back, the rear squeegee and vacuum system are not on, which allows the solution to stay on the floor emulsifying the grease and oil. If the operator stops moving in either direction, the machine will automatically raise the scrub deck and turn off the brushes. After double scrubbing, the operator should use *the vacuum only mode* to recover the dirty solution water from the floor.

4. Vacuum Only Mode

When the machine is running in this mode, the machine will only lower the rear squeegee and turn on the vacuum system to recover the dirty solution from the floor. This mode is usually chosen after double scrubbing to recover the dirty solution but it can also be used to pick up spills. When the operator sets the *directional switch* to *forward*, the rear squeegee will be lowered to the floor as the vacuum turns on, pulling the dirty solution water from the rear squeegee into the recovery tank. If the operator stops moving forward and sets the directional switch to *reverse*, the rear squeegee will retract (protecting it from damage) and the vacuum motor will turn off after a few seconds. If the operator quits moving in either direction, the machine will automatically raise the squeegee and turn off the vacuum motor after a few seconds.

5. Transport Mode

When the machine is set in this mode, none of the cleaning functions of the machine will operate. This mode is only used to transport the machine from one location to another at a faster rate of speed.

6. Water Flow

Located on the left side of the control console. This knob controls the rate at which water / solution is distributed to the scrub deck. The farther the knob is turned clockwise the more water will be distributed.

7. Speed Control

Located on the right side of the control console. This knob controls the propelling speed of the machine. The farther the knob is turned clockwise the faster the machine will travel. As discussed earlier, the directional switch governs the direction of travel the machine will take.

Power Save Mode

The ES 2832 is equipped with a power save feature to conserve battery power. If the key switch power is left ON and none of the controls are activated for a period of fifteen minutes, the ES 2832 automatically goes into “power down mode” and turns OFF the power to conserve your batteries in case the operator forgets to turn the key switch off or leaves the machine unattended.

Emergency Disconnect Handle

This handle is located beneath the control console off center to the right. When the *red* emergency handle is pulled, power will be turned off. Use this button in case of a machine emergency. To reactivate, return the handle back to its original position, correctly seated in the receptacle. *All operational settings are retained even when the power is turned off and on.*

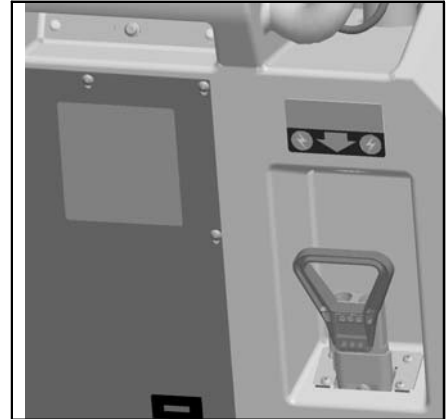

Circuit Breaker

The circuit breaker is located under the emergency belly bar. The **100-amp breaker** protects the main system circuit (controller). Each main component is individually protected with an internal breaker built-in the controller. (See fault code table) and can be reset by turning the key switch off a few seconds and then on again.

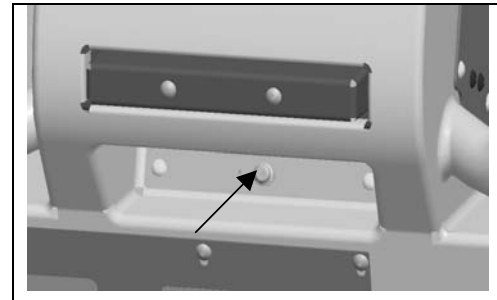

Battery Compartment

The battery compartment is located on the rear of the machine under the recovery tank. Unlatching the two safety latches on the side of the machine enables the operator to tilt the recovery tank and access the batteries for servicing and maintenance (make sure recovery tank has been drained before tilting). The battery compartment contains six 6-volt batteries connected in series. Connect the batteries according to the battery connection diagram (*see diagram*). The recommended batteries are 275Ah (Minuteman P/N 956740).

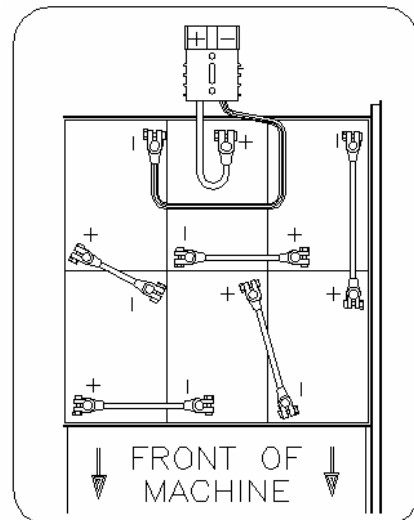

Scrub Deck

Minuteman offers two deck types (*Cylindrical and Disc*) to fit your specific needs. The ES2832 design is very dynamic wherein the decks are interchangeable in a matter of minutes whenever necessary (removal of four bolts, and two quick-connects). The *cylindrical brush deck* has five built-in spray jets to uniformly dispense cleaning solution on the floor and a wet sweeping debris tray to collect loose objects on the floor. The *disc brush deck* dispenses cleaning solution through the center hub and contained within the bristle area for efficient agitation of cleaning solution to the floor and channeled to the rear of the machine. The disc brushes are also easily removed and installed with the quick release clamp by using any of the three access doors. Another nice feature that these scrub decks have is the ability to have uniform brush pressure applied to the floor at all times. Since the scrub deck brush pressure is computer controlled, it will automatically adjust and compensate to uneven contours on the floor while maintaining brush pressure.

Cylindrical Scrub Deck

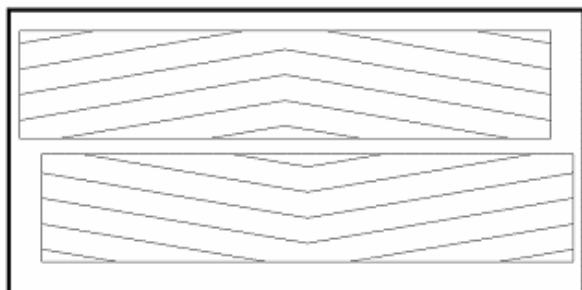
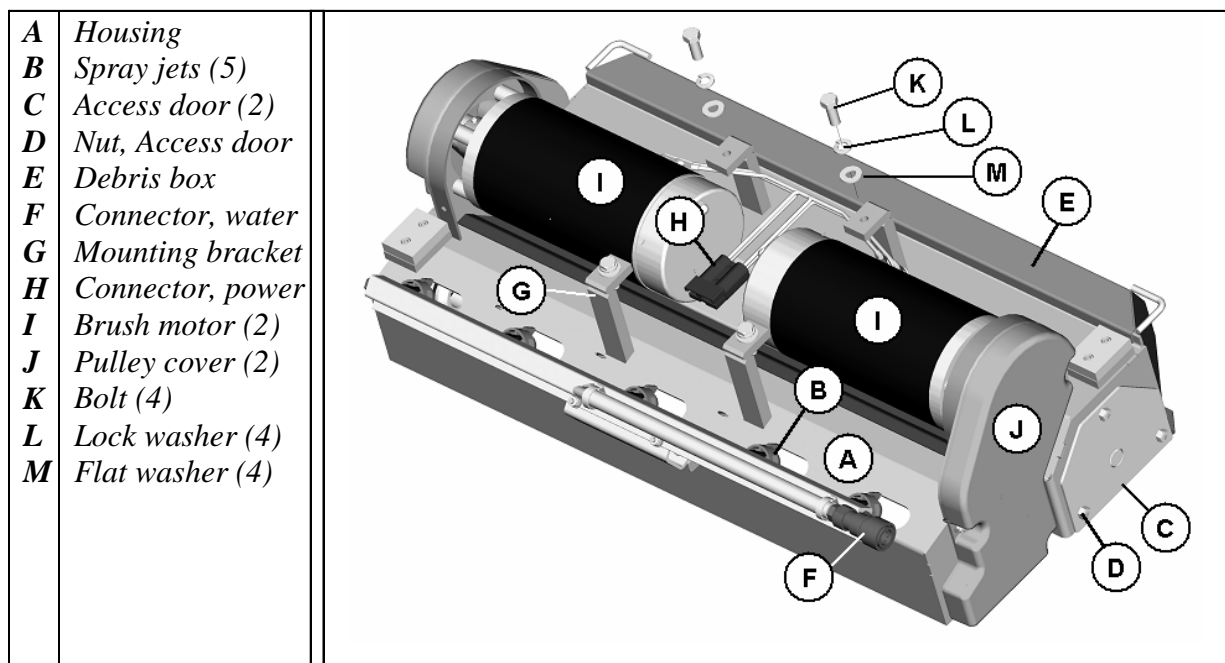

Cylindrical scrub brushes must be installed with the chevron pattern pointing away from each other for best water and debris pick up.

Disc Scrub Deck

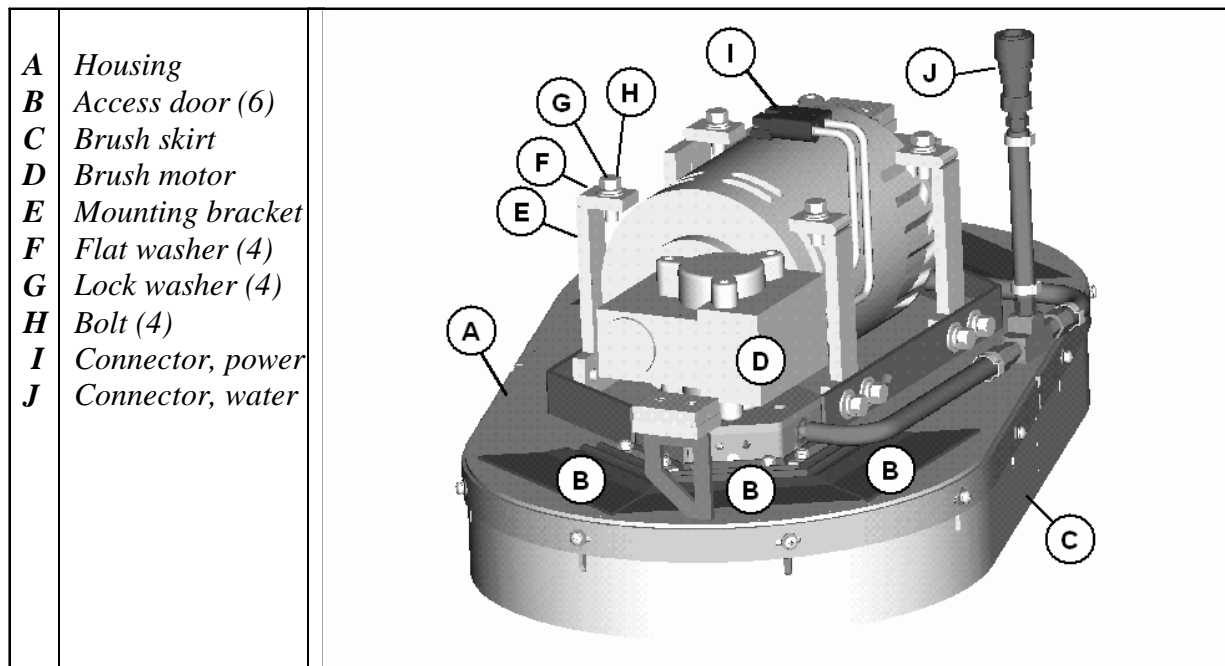

Scrub Deck Installation

When installing a cylindrical scrub deck to a machine:

Install brushes **after** the deck has been mounted to avoid flat spots on the brushes.

Use a piece of cardboard underneath the deck to prevent scratches to the painted surface when sliding the deck under the machine.

Make sure the scrub deck is oriented correctly with the spray jets towards the front of the machine.

When installing a disc scrub deck to a machine:

Install brushes on the scrub deck; this aids the installer in sliding the deck assembly into position.

Make sure the scrub deck is oriented correctly with the solution hose tee fitting towards the front of the machine.

Installation Instructions

Park the machine on a flat or level surface.

Remove the 2 pins that fasten the deck cover on the machine.

Turn the key switch to the ON position and select the transport mode on the dashboard.

Slide the scrub deck assembly underneath the machine (follow instructions as described above).

Position the scrub deck to align the mounting brackets with the mounting lugs on the lift linkage.

Lower the lift linkage to the floor by pressing the raise/lower deck button.

Lower the lift linkage mounting lugs until they barely touch the scrub deck mounting brackets.

Fasten with the four (4) 711242 bolts, 711515 flat washer and 711546 lock washer.

For cylindrical scrub deck only:

Remove the two access doors (one each end) by removing the (3) nyloc nuts.

Install the brushes by sliding through the access opening.

Align the notches on the brush with the drive pins on the hub.

Push brush all the way until it bottoms out.

Insert access door hub to the other end of brush.

Reinstall nuts and tighten.

Rear Squeegee

The rear squeegee is the main element that acts as the conduit that transfers the spent solution into the recovery tank. A daily maintenance check of this component is essential to have optimum machine performance. The rear squeegee assembly is equipped with a universal front blade that allows the operator the option to use a slotted and a non-slotted side for specific applications. Each blade configuration has two usable edges. The rear blade however has four usable edges.

The squeegee is pre-adjusted at the factory. Adjustments may be required to get optimum performance for different floors and conditions.

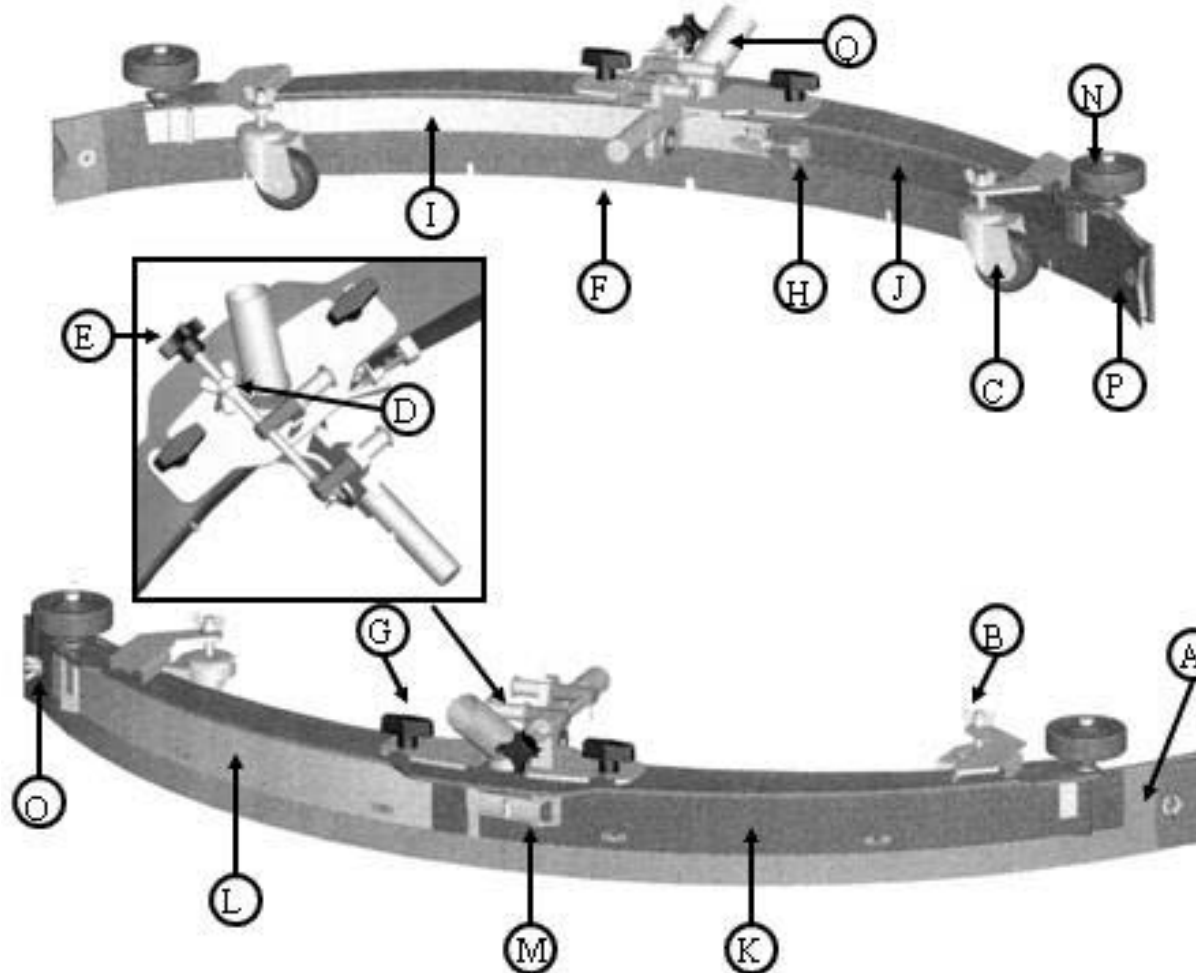

Rear Squeegee Components

- | | |
|-------------------------------|----------------------------|
| A. Rear squeegee blade | J. Front strap (short) |
| B. Wing jam nut (2) | K. Rear strap (latch side) |
| C. Swivel Caster (2) | L. Rear strap (catch side) |
| D. Wing Jam Nut | M. Latch |
| E. Turnbuckle Adjustment Knob | N. Guide wheels (2) |
| F. Front squeegee blade | O. Nylon wing bolt (2) |
| G. Wing bolt (2) | P. Nylon bolt (2) |
| H. Toggle clamp | Q. Recovery hose intake |
| I. Front strap (long) | |

Rear Squeegee Adjustment

Ensure that the scrubber is on a relatively flat surface. Turn on the key switch and select the **Vacuum only** mode. This lowers the squeegee to the floor and turns the vacuum motor on. Move the scrubber one or two feet forward slowly while someone behind the machine checks the rear squeegee blade (item **A**) for uniform deflection to the floor.

If uneven deflection or lay is evident, minor adjustments may be necessary to avoid streaking and uneven wear on the blade.

To correct this, loosen the wing jam nut (item **B**) in order to adjust the caster height. If the squeegee blade is deflecting too much, the casters (item **C**) need to be lowered to control the down pressure. Lower the caster by turning the exposed threaded stem on the caster clockwise. Make the adjustment a few turns at a time. **Repeat step 2.**

If the blades are not deflecting enough, raise the caster by turning the stem counter-clockwise to adjust the caster height to allow more down pressure on the squeegee. **Repeat step 2.**

Make sure there is even deflection on the entire length of the rear blade. Adjust the casters and retighten the wing jam nuts to lock the caster setting in place.

Pitch adjustment is necessary if the outer ends on the squeegee blade do not contact the floor and there is too much deflection in the middle area or if the outer ends are over deflected and there is no contact in the middle.

To adjust the pitch, repeat step 2.

Loosen the lock nut (item **D**) in the turnbuckle assembly. Turning the turnbuckle (item **E**) clockwise or counter-clockwise controls the forward and backward pitch of the squeegee.

Having the rear blades deflected uniformly along its entire length is the desired set-up.

Repeat step 2 until desired set-up is achieved.

In certain applications where a non-slotted front wiper blade (item **F**) is needed, detach the rear squeegee assembly by loosening the two wing bolts (item **G**). Unlock the toggle clamp (item **H**) on the front squeegee to release the front long strap (**I**) and slide the front short strap (item **J**). Flip the blade over to the non-slotted side. Reattach the straps and lock the clamp back in place.

You can also easily replace the rear blade by unlatching the latch (item **M**) and removing the two rear straps (items **K** & **L**) by sliding them off the assembly. You can then flip the blade over in order to use a new edge for better wiping action.

Off Aisle Wand (optional)

The ES2832 is equipped with a ready-to-use built-in telescoping off-aisle wand system for use in hard to reach areas. This integrated system eliminates attaching hose for use and detaching hoses for storage. By turning the *pump switch* ON (located behind the right handle of the control console) the off-aisle wand is ready to use in seconds. After use, simply flip the switch OFF and return the wand to its original storage location. The wand is also equipped with the patented flip-flop tool that allows the operator to switch from scrub brush to squeegee tool by just rotating the tool end.

Off Aisle Wand Tool

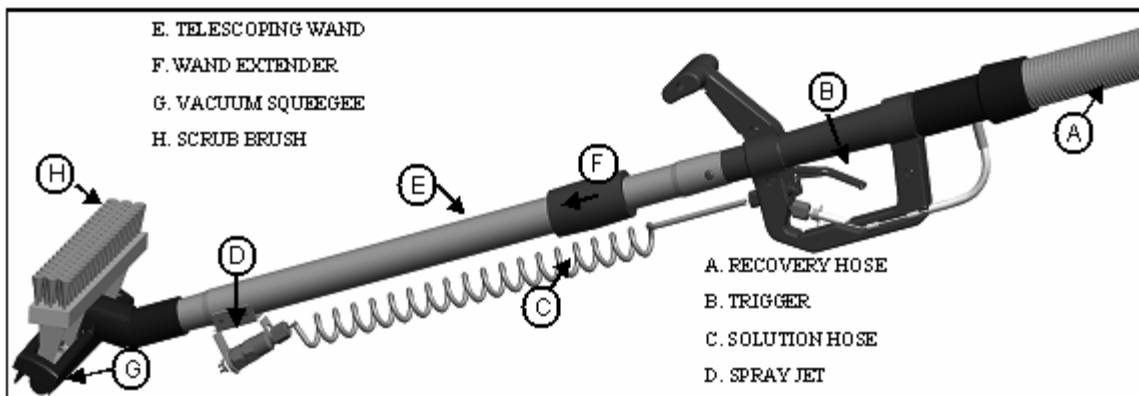

The off-aisle wand tool as described in the previous page is composed of the following items:

The **recovery hose** is connected to the end of the wand on one end and to the recovery tank hose on the other end. This hose has swivel cuffs on both ends that allow the operator a good range of motion and the solution hose to be inside the recovery hose.

The **trigger** controls the solution flow to the spray jet. Squeezing the trigger opens an internal valve to dispense cleaning solution.

The coiled **solution hose** acts as a conduit from the trigger to the spray jet, and allows hose to be extended along with the wand.

The **spray jet** dispenses the cleaning solution to soak soiled areas that are not accessible to the main scrub deck.

The **telescoping wand** allows the length to be adjusted for operator comfort and better storage when not in use.

Sliding the **wand extender** forward (as shown above) extends the wand length during use and retracts the wand by pulling it back for the storage position.

The flip-flop tool gives the operator complete flexibility when changing from the **scrub brush** mode to **vacuum squeegee** mode by simply rotating the end.

When the off-aisle wand switch is turned ON, six LEDs on the battery gauge will flash to indicate that you are in the off-aisle tool mode. This switch turns on the pump to supply solution to the wand spray jet and the vacuum motor to recovery the dirty water.

The ES2832

This machine was designed with total operator comfort and ease of use in mind. All machine components have been designed as a total system to efficiently clean dirty floors. The ES2832 has four available scrub head types and sizes to fit specific applications. *Please contact your Minuteman representative for specific recommendations for the correct scrub head type, size, and brush type and chemical applications.*

Before using the machine, always perform the following steps to ensure proper machine operation.

- Check under the machine for leaks.
- Check the rear squeegee for wear and damage.
- Check the solution and recovery tank levels.

After using the machine, always perform the following steps:

Check the battery charge level. Charge batteries if necessary. When charging batteries, extra precaution is required:

Battery acid can cause burns. When working on or around batteries, always wear protective clothing and safety glasses. Remove metal jewelry. Do not lay tools or metal objects on top of the batteries.

Charging batteries generate explosive gasses. **DO NOT CHARGE BATTERIES WHEN OPEN FLAMES OR SPARKS ARE PRESENT. DO NOT SMOKE.** Make sure the charger is turned off before disconnecting it from the batteries. Charge the batteries in a well-ventilated area. Fluid levels should be checked before and after charging and maintained at the proper levels. If low, add distilled water until the metal plates are covered. If the machine is not used for an extended period of time, batteries should be kept fully charged with a boost charge once a week.

- Check for wire, string, or twine wrapped around the scrub brushes.
- Check the rear squeegee for wear and damage.
- Check the rear squeegee suction hose and off-aisle wand hose for obstructions.
- Empty and clean the debris box (cylindrical systems only).
- Drain and clean the recovery tank.
- Check under the machine for leaks.
- Check the service records to determine maintenance requirements.

WARNING!

- Be sure you understand the machine controls and their functions.**
- While on ramps or inclines, avoid sudden stops when tanks are filled.**
- Avoid abrupt sharp turns. Slow down driving speed when going downhill.**

Machine Operation

Follow the instructions in preparing the machine for use as described in this manual.

Turn the **Key switch ON (I)**. The **Battery Gauge** will light up for a few seconds then display the *Battery Condition*. Do NOT attempt to operate during this time.

Select one of the five available **Modes** on the **Control Console** for the required task. Refer to the *Main Keyboard section* of this manual for a complete description of the functions.

Determine the direction you need to travel by selecting **forward** or **reverse** on the **Directional Switch**. Vary the acceleration knob to propel the machine at the desired speed. Squeezing the **Accelerator Handle** turns on the *Transport, Brushes, Water Flow, Vacuum* and lowers the *Rear Squeegee* accordingly to the Mode selected. If the operator triggers the accelerator handle before, or turns the key switch “ON” at the same time, the machine will not move as a safety precaution.

Simply release the handle and squeeze the handle again to drive the machine. Please refer to the *Main Keyboard section* of this manual for a complete description of the functions.

When **Reverse** is selected on the Directional Switch, the **Rear Squeegee** automatically is raised.

However, the Scrub brushes will continue to rotate and solution will continue to flow.

Start scrubbing by driving the machine forward in a straight line at 3/4 speed and overlap each path by 2 to 3 inches. Adjust your speed and solution flow according to the condition of the floor.

When scrubbing, check behind the machine occasionally to see that all the dirty water is being picked up. If streaking occurs, your **Water Flow** setting may be *too high*, the **Recovery Tank** may be *full*, the **Squeegee hose** may be *clogged*, or the **Rear Squeegee** may require some *adjustment or cleaning*.

Make the necessary adjustments on the **Rear Squeegee** if streaking occurs both in straight paths and in turns. Please refer to the *Rear Squeegee* section of this manual before making any adjustments.

The recovery tank has an overflow protection to guard against water from entering the vacuum system when the recovery tank is full. A ball float shut-off system has been integrated into the Recovery Tank. When the dirty water reaches a certain level, the ball gets suctioned into the vacuum manifold and blocks the airflow thus, preventing the machine from picking up more liquid. When this happens, the operator is then required to stop scrubbing and empty the recovery tank.

To stop scrubbing, select the **Transport mode**. This will automatically stop the **Solution Flow**, raise the **Scrub deck**, and raise the **Rear squeegee** (there is a 15 second delay for the vacuum motor and a 8 second delay on the rear squeegee).

Drive the ES to a designated dirty water disposal area and empty the Recovery tank. To empty, remove the **Drain hose** from its storage hanger. Unscrew the plug and hold the hose end above the water level in the tank to avoid sudden, uncontrolled flow of dirty water. With the plug completely off, carefully direct the water flow to the desired drain. Reinsert the plug and tighten and return to its storage hanger.

The recovery tank should be rinsed out to remove solids in the tank. Open the **Cleanout cap** to remove the **Stopper plug**. Tilt the recovery tank (similar to accessing the batteries) and clean the sludge that has settled in the sump area by either back flushing or by scraping it out. Be sure to tightly secure the **Stopper plug** and cleanout cap before continuing to operate the scrubber.

Refill the solution tank and continue scrubbing until the job is done or when the machine runs out of power.

The **battery gauge bar icon** will flash to signal the operator that the machine is almost out of power. Once this signal is displayed to the operator, *all functions will shut off* (brush will turn off and the scrub deck will raise up, water flow will cease, the rear squeegee will raise up and the vacuum motor will turn off) including the transport mode. The machine then will only have a few minutes left of reserve power for a short *Vacuum only mode* to pick up remaining solution on the floor and *Transport* power to drive to the battery recharging station.

After Use

When finished scrubbing, select the **Transport mode**, *all functions will shut off* (brush will turn off and the scrub deck will raise up, water flow will cease, the rear squeegee will raise up and the vacuum motor will turn off). Drive the machine to a service area for daily maintenance and review items that may need service.

Empty the solution tank, by opening the **solution hose valve** into a drain. Rinse the tank with clean water to prevent any build-up of dried up chemicals that could cause clogging in the plumbing.

Empty the recovery tank as described on line **11** and **12**.

Remove the **brushes** or pad holders and rinse them in warm water and hang to dry.

Remove the **rear squeegee**, rinse with warm water and reinstall after cleaning.

Check the **maintenance schedule** on the next page and perform any required maintenance before storing the machine.

Store the machine indoors in a clean dry place. Keep from freezing. Leave solution and recovery tank lids open for ventilation to prevent odor build-up.

Turn **Key switch OFF (O)** and remove key.

Maintenance Schedule

Daily	Weekly	Monthly	Yearly
Charge Batteries	Check Each Battery Cell(s) Water Level	Lubrication – Grease Fittings, chains, etc.	Check Carbon Brushes
Check/Clean Tanks & Hoses	Inspect Scrub Housing Skirts		
Check/Clean/Rotate the Brushes/Pads	Inspect and Clean Solution Filter		
Check/Clean the Squeegee	Clean Spray jets on Cylindrical System		
Check/Clean Vacuum Shut-Off Float			
Check/Clean the Vacuum Motor Foam Filter			
Clean Hopper on Cylindrical System			

Have Minuteman check the vacuum motor carbon motor brushes once a year or after 300 operating hours. The brush motor carbon brushes should be checked every 500 hours or once a year.

NOTE: Refer to the Service Manual for more detail on maintenance and service repairs.

Lubricating the Machine

Regularly scheduled lubrication of certain machine parts should be performed to insure trouble-free operation of the machine. *Apply a generous amount of grease into the fittings on the machine until grease seeps out around the bearings.*

The grease points are listed below:

Rear squeegee caster wheel axle (2)

Rear squeegee caster wheel stem (2)

Apply lubricant or light machine oil to lubricate the:

Rear squeegee general pivot points

Scrub deck linkages

Drive wheel assembly seals.

General Machine Troubleshooting

Problem	Possible Cause	Remedy
Poor water pick-up	Worn or torn squeegee blades	Rotate or replace blades
	Squeegee out of adjustment	Adjust so blades touch floor evenly across entire width
	Recovery tank full	Empty recovery tank
	Recovery tank drain hose leak	Secure drain hose cap or replace
	Recovery tank lid gasket leak	Replace gasket lid cover properly
	Debris caught in squeegee	Clean squeegee
	Vacuum hose clogged	Remove debris and flush hose
	Using too much solution	Adjust solution control valves
Poor scrubbing performance	Vacuum hose to squeegee or recovery tank disconnected to squeegee or damaged	Reconnect or replace squeegee hose
	Worn brushes	Rotate or replace brushes
	Wrong brush or cleaning chemical	Consult Minuteman
	Debris caught on scrub brushes	Remove debris
	Moving machine too fast	Slow down
	Not using enough solution	Adjust solution flow setting
	Low battery charge	Recharge batteries
	3 Bars Flashing on Battery Indicator	Reduce scrub brush pressure. Broken brush drive belts on cylindrical system, replace belt(s). Check power connection. Reconnect plugs. Reset machine: Turn key switch off and restart.
Inadequate solution flow or no solution to the floor	Solution tank empty	Fill solution tank
	Recovery tank full	Empty recovery tank
	Solution lines, valves, filter or spray jets clogged	Flush lines, and clean solution filter and spray jets.
	Solution solenoid valve	Clean or replace valve
No solution to off-aisle wand spray jet	Recovery tank full	Empty recovery tank
	Solution tank empty	Refill solution tank
Machine does not run	Main system controller	Check error fault codes (See service manual)
	Tripped 100 amp circuit breaker	Check for electrical short circuit Reset machine: Reset and turn key switch off and restart.
No FWD/REV drive	Drive system speed controller. 2 bars flashing on battery indicator.	Check error fault codes (See service manual) Reset machine: Turn key switch off and restart.
	Emergency stop switch tripped	Activate switch by turning as indicated by arrows.
Vacuum motor does not turn on	Recovery tank full	Empty recovery tank
	Excessive foaming in recovery tank.	Empty recovery tank. Use less or change chemical. Use defoaming agent.
	5 bars flashing on battery indicator.	Check for motor overload. Reset machine: Turn key switch off and restart.
Poor sweeping performance (Cylindrical System)	Debris box full	Empty and clean debris box
	Brushes worn	Replace brushes
	Bristles have taken a set	Rotate brushes

Diagnostic Codes	
<i>The number of flashing bars on the battery gauge represent fault codes as indicated below:</i>	
Low battery voltage <i>Check condition of battery and connections</i>	1
Traction Motor fault <i>Check all connections between the motor and the control system</i>	2
Brush Motor fault <i>Check all connections between the motor and the control system</i>	3
Freewheel Errors <i>Check condition of freewheel switch and connections</i>	4
Vacuum Motor fault <i>Check all connections between the motor and the control system</i>	5
Off-Aisle Wand Activated <i>Check Off-aisle wand switch position</i>	6
Throttle fault <i>May indicate incorrectly wired or faulty potentiometer</i>	7
Control system fault <i>Check all connections are secure</i>	8
Solenoid brake fault <i>May indicate open or short circuit solenoid brake</i>	9
High battery voltage <i>Check condition of battery and connections</i>	10
Throttle Displaced on start up <i>Restart key switch-throttle was activated prior to ignition</i>	Ripple
Please refer to manual for detailed trouble shooting information	
715904	

<i>Scrubber System Faults External to TRIO+</i>			
LED Readout	Code	Fault Description	Corrective Action
1	2C00	LOW BATTERY ERROR	Battery Charge to low. Recharge battery.
1	2C01	LOW BATTERY ERROR2	Battery Charge to low. Recharge battery.
1	2C02	SOFT BATTERY LOCKOUT OCCURRED	Battery Charge to low. Recharge battery.
1	2C03	SOFT BATTERY LOCKOUT 2 OCCURRED	Battery Charge to low. Recharge battery.
2	7800	TRACTION MOTOR FAULT-1	Disconnect Battery for 60 seconds. Reconnect battery
2	7801	TRACTION MOTOR OVER CURRENT ERROR	Disconnect Battery for 60 seconds. Reconnect battery
2	7802	SOFT TRACTION MOTOR IN FOLDBACK STATE	Traction Motor being overloaded or Foldback parameters set too low.
2	7803	MOTOR LINE VOLTAGES INSTABILITY TIMEOUT	Disconnect Battery for 60 seconds. Reconnect battery
2	7880	TRACTION SPEED INPUT OUT OF RANGE	
3	7600	SOFT BRUSH MOTOR DISCONNECTED ERROR	
3	7601	SOFT BRUSH CURRENT FOLDBACK	
3	7602	SOFT BRUSH CURRENT FOLDBACK2	
3	7603	SOFT BRUSH CURRENT FOLDBACK3	
3	7604	SOFT BRUSH INHIBIT	
3	7605	BRUSH STARTUP OVERCURRENT DETECTION	

5	7700	SOFT VACUUM MOTOR DISCONNECTED ERROR	
5	7701	SOFT VACUUM CURRENT FOLDBACK	
5	7702	SOFT VACUUM CURRENT FOLDBACK2	
5	7703	SOFT VACUUM CURRENT FOLDBACK3	
7	0810	TILLER FAULT-1	For all Tiller Diagnostic Codes:
7	0811	TILLER MAX WIPER DIFFERENCE ERROR	1- Check throttle wiring for shorts or opens. Repair or replace as necessary. 2- If Diagnostic Code is not cleared, then replace throttle.
7	0812	TILLER MAX PULL DOWN DIFFERENCE ERROR	
7	0813	TILLER MAX PULL SAFE DIFFERENCE ERROR	
7	0814	TILLER REFERENCE ERROR	
7	0815	TILLER LO REFERENCE ERROR	
7	0816	TILLER HI REFERENCE ISO ERROR	
7	0817	TILLER LO REFERENCE ISO ERROR	
7	0818	TILLER ERROR BOTH HAVE READINGS	
8	1310	EXCESSIVE CURRENT TRIP	Disconnect Battery for 60 seconds. Reconnect battery
8	1311	SOFT AUX1 OVERCURRENT OCCURRED	Device connected to Aux-1 exceeded current limit. Check wiring or replace device.
8	1312	SOFT AUX2 OVERCURRENT OCCURRED	Device connected to Aux-2 exceeded current limit. Check wiring or replace device.
8	1313	SOFT AUX3 OVERCURRENT OCCURRED	Device connected to Aux-3 exceeded current limit. Check wiring or replace device.
8	1314	SOFT AUX4 OVERCURRENT OCCURRED	Device connected to Aux41 exceeded current limit. Check wiring or replace device.
8	1318	SOFT BRAKE LIGHT OVERCURRENT OCCURRED	Brake light circuit exceeded current limit. Check wiring or replace device.
8	131C	SOFT ALARM OVERCURRENT OCCURRED	Alarm circuit exceeded current limit. Check wiring or replace device.
8	1321	AUX1 OVERCURRENT 2 OCCURRED	Device connected to Aux-1 exceeded current limit. Check wiring or replace device.
8	1322	AUX2 OVERCURRENT 2 OCCURRED	Device connected to Aux 2 exceeded current limit. Check wiring or replace device.
8	1411	ERROR AUX 1 POSITIVE SHORTED_LOW	Check Aux-1 wiring and device connected to Aux-1. Repair or replace as necessary.
8	1412	ERROR AUX 1 NEGATIVE SHORTED LOW	Check Aux-1 wiring and device connected to Aux-1. Repair or replace as necessary.
8	1413	ERROR AUX 2 POSITIVE SHORTED LOW	Check Aux-2 wiring and device connected to Aux-2. Repair or replace as necessary.
8	1414	ERROR AUX 2 NEGATIVE SHORTED LOW	Check Aux-2 wiring and device connected to Aux-2. Repair or replace as necessary.
8	7900	EMERGENCY STOP ERROR	Disconnect Battery for 60 seconds. Reconnect battery
9	1501	BRAKE FAULT 2	Check Brake circuit wiring and brake. Repair or replace as necessary.
9	1507	BRAKE OVER CURRENT ERROR	Check Brake circuit wiring and brake. Repair or replace as necessary.
10	1600	HIGH BATTERY ERROR	Battery is overcharged or damaged. Replace battery.
Ripple	2F01	TILLER DISPLACED ERROR	Throttle displaced on Power-up. Release throttle and then re-engage throttle.
Ripple	7901	SOFT BELLY BUTTON ACTIVATED	Disconnect Battery for 60 seconds. Reconnect battery

Main Assembly - Disc Scrub Decks / Brushes

BILL OF MATERIAL - ES28DQP			
ITEM	PART NO.	REQ'D	DESCRIPTION
1	281601	1	DISK SCRUBDECK ASSY 28" NO BRUSH
2	320745	1	ES2832 BUMPER COVER ASSY, 28"
3	320930-1	1	ES2832 SQUEEGEE BLADE ASSY
4	320940-1	1	SQUEEGEE MT BRKT ASSY
5	3313135	2	BRUSH SCRUB 14" PLASTIC NYLON
5A	3313125	2	POWER DRIVE-14"POWERGRIT 80S/S
5B	3313127	2	POWER DRVE-14" POWERGRIT 46HDS
5C	3313131	2	BRUSH-SCRUB 14" PLAS WIRE
5D	3313133	2	BRUSH-SCRUB 14" PLAS BUTCHWIRE
5E	3315494	2	BRUSH-14" PWR DRIVE W/PAD HLDR
5F	3315386	2	POWER DRIVE-14" POWERGRIT 120AGS
6	ES2832	1	ES2832 BASE ASSY

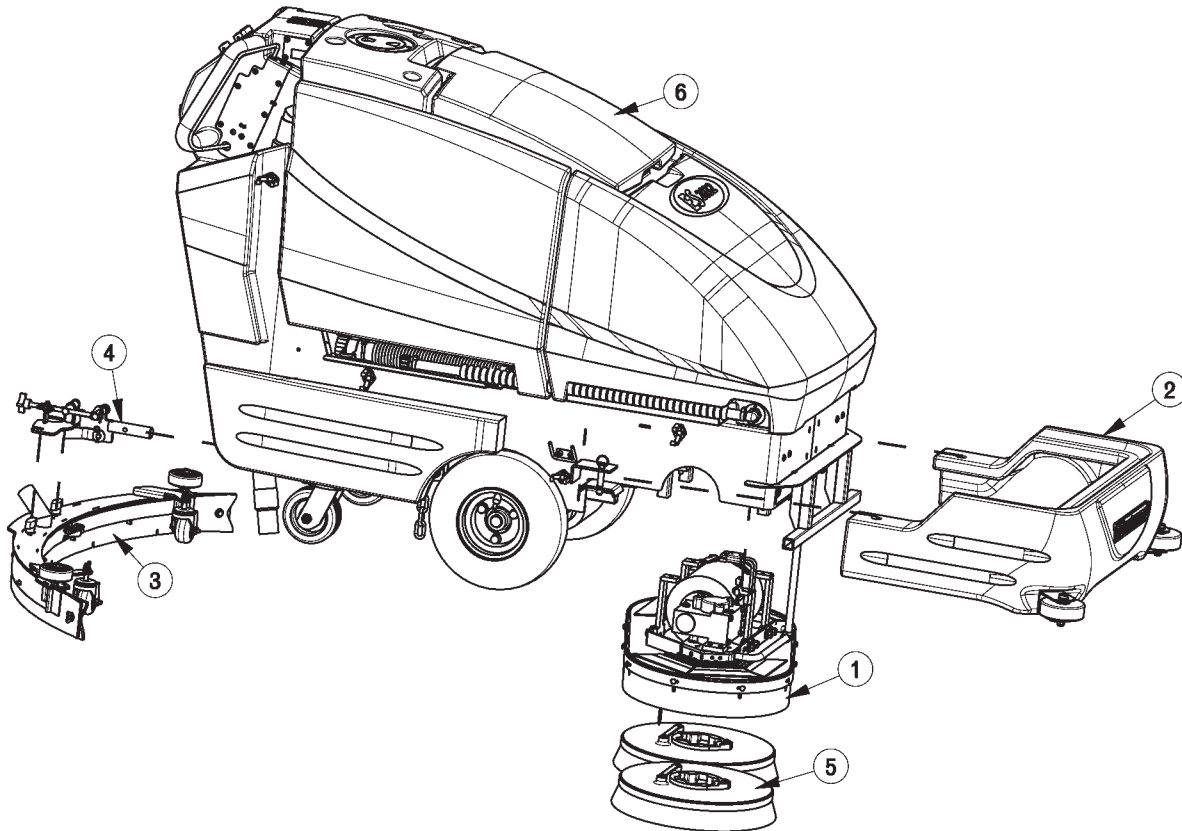

BILL OF MATERIAL - ES32DQP			
ITEM	PART NO.	REQ'D	DESCRIPTION
1	281651	1	DISK SCRUBDECK ASSY 32" NO BRUSHES
2	320746	1	ES2832 BUMPER COVER ASSY, 28"
3	320930-1	1	ES2832 SQUEEGEE BLADE ASSY
4	320940-1	1	SQUEEGEE MT BRKT ASSY
5	3313136	2	BRUSH-SCRUB 16" PLASTIC NYLON
5A	3313126	2	POWER DRIVE-16"POWERGRIT 80S/S
5B	3313128	2	POWER DRIVE-16"POWERGRIT 46HDS
5C	3313132	2	BRUSH-SCRUB 16" PLAS WIRE
5D	3315385	2	POWER DRIVE-16"POWERGRIT 120AGS
5E	3315495	2	BRUSH-16" PWR DRIVE W/PAD HLDR
6	ES2832	1	ES2832 BASE ASSY

BILL OF MATERIAL - ES28CQP			
ITEM	PART NO.	REQ'D	DESCRIPTION
1	281501	1	CYLINDRICAL SCRUBDECK ASSY, 28" NO BRUSHES
2	281520	2	BRUSH, CYL 28" .022 NYLON
2A	281521	2	BRUSH-CYL 28" .028 NYL
2B	281522	2	BRUSH-CYL 28" .026 PP
2C	281525	2	BRUSH-CYL 28" SCRUBGRIT II 120
2D	281526	2	BRUSH-CYL 28" NYLO GRIT 80GR
2E	281527	2	BRUSH-CYL 28" STRATAGRIT 46GR
2F	281528	2	BRUSH-CYL 28" STRATAGRIT PLUS 36GR
3	320745	1	ES2832 BUMPER COVER ASSY, 28"
4	320930-1	1	ES2832 SQUEEGEE BLADE ASSY
5	320940-1	1	SQUEEGEE MT BRKT ASSY
6	ES2832	1	ES2832 BASE ASSY

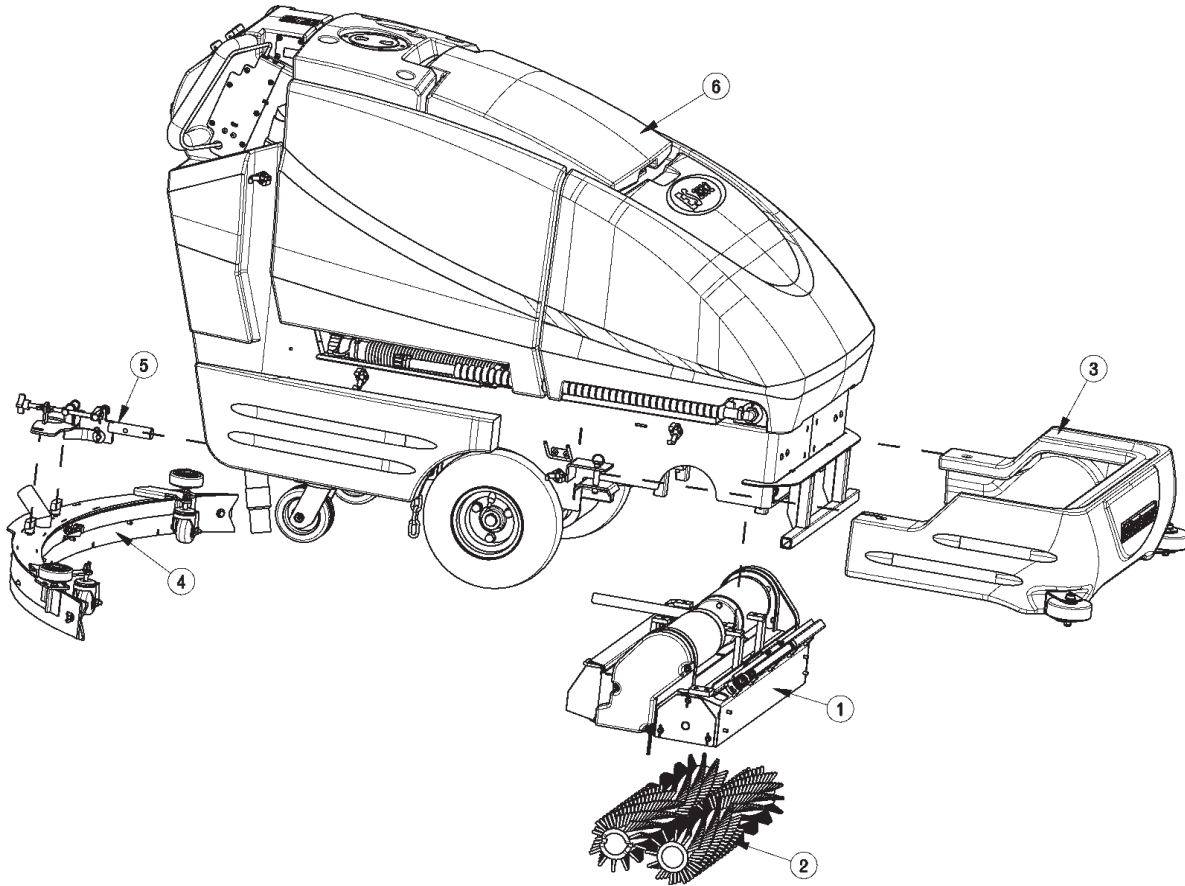

BILL OF MATERIAL - ES32CQP			
ITEM	PART NO.	REQ'D	DESCRIPTION
1	281551	1	CYLINDRICAL SCRUBDECK ASSY, 32" NO BRUSHES
2	281530	2	BRUSH-CYL 32" .022 NYL
2A	281531	2	BRUSH-CYL 32" .028 NYL
2B	281532	2	BRUSH-CYL 32" .026 PP
2C	281535	2	BRUSH-CYL 32" SCRUBGRIT II 120GR
2D	281536	2	BRUSH-CYL 32" NYLO GRIT 80GR
2E	281537	2	BRUSH-CYL 32" STRATAGRIT 46GR
2F	281538	2	BRUSH-CYL 32" STRATAGRIT PLUS 36GR
3	320746	1	ES2832 BUMPER COVER ASSY, 28"
4	320930-1	1	ES2832 SQUEEGEE BLADE ASSY
5	320940-1	1	SQUEEGEE MT BRKT ASSY
6	ES2832	1	ES2832 BASE ASSY

Base Assembly

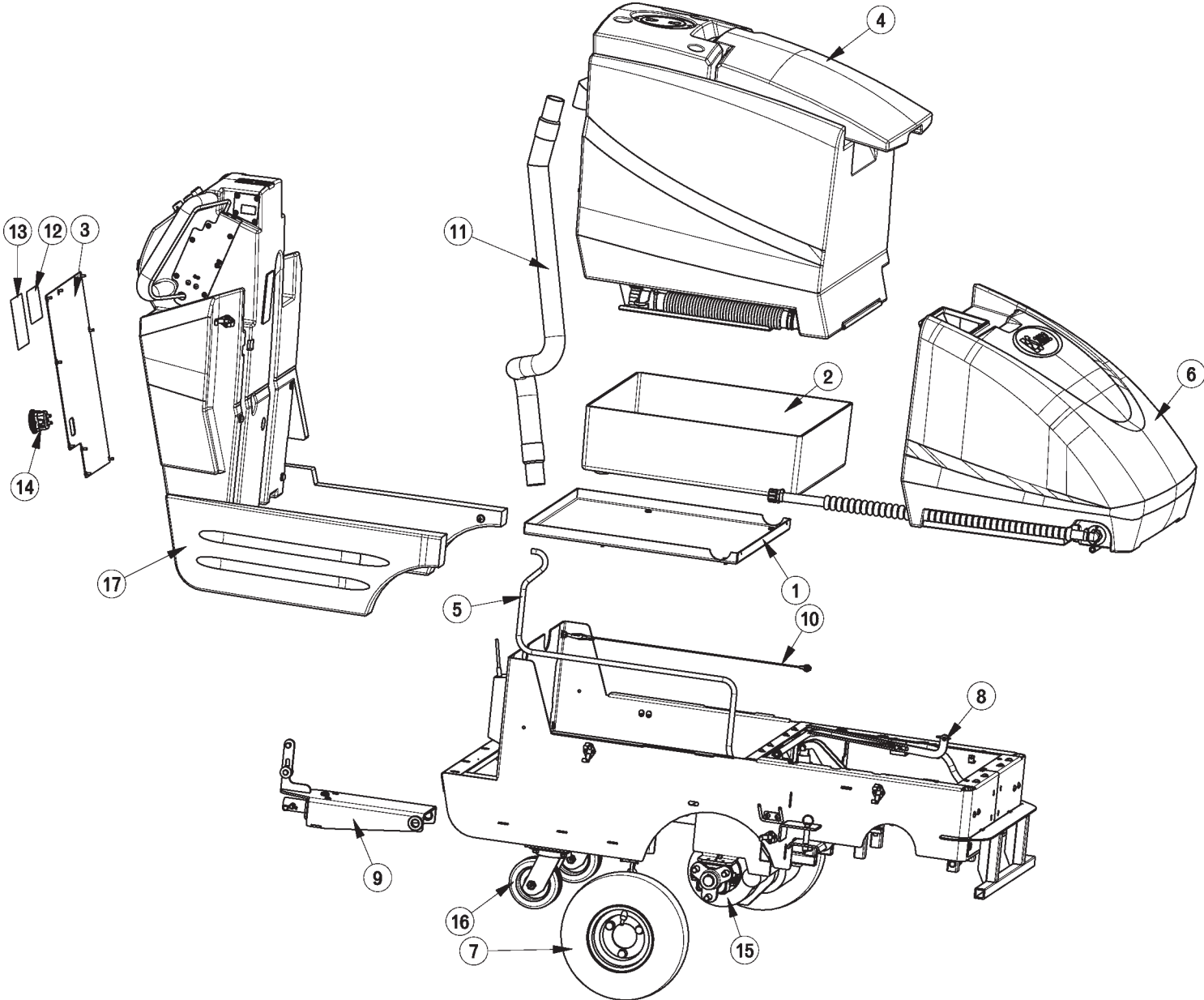



BILL OF MATERIAL - ES2832			
ITEM	PART NO.	REQ'D	DESCRIPTION
1	320118	1	BATTERY TRAY
2	320215	1	BATTERY TRAY LINER
3	320756	1	ES2832 E-PANEL TOP
4	320830	1	ES2832 RECOVERY TANK ASSY
5	320834	1	HOSE 1/4" X 36"
6	320840	1	ES2832 SOLUTION TANK ASSY
7	320902	2	WHEEL, PNEUMATIC 12'
8	320912	1	SOLUTION TANK STOP
9	320920	1	SQUEEGEE LIFT MECH ASSY
10	320973	1	RECOVERY TANK CABLE ASSY
11	450090	1	VAC HOSE
12	715619	1	DECAL, WARNING
13	715904	1	DECAL, DIAGNOSTIC CODES
14	740539	1	HOUR METER 10 - 80 VDC
15	744151	1	TRANSAXLE 18" 36V
16	827110	2	CASTER 5-INCH
17	320820G	1	ES2832 CONSOLE ASSY

Drive Assembly

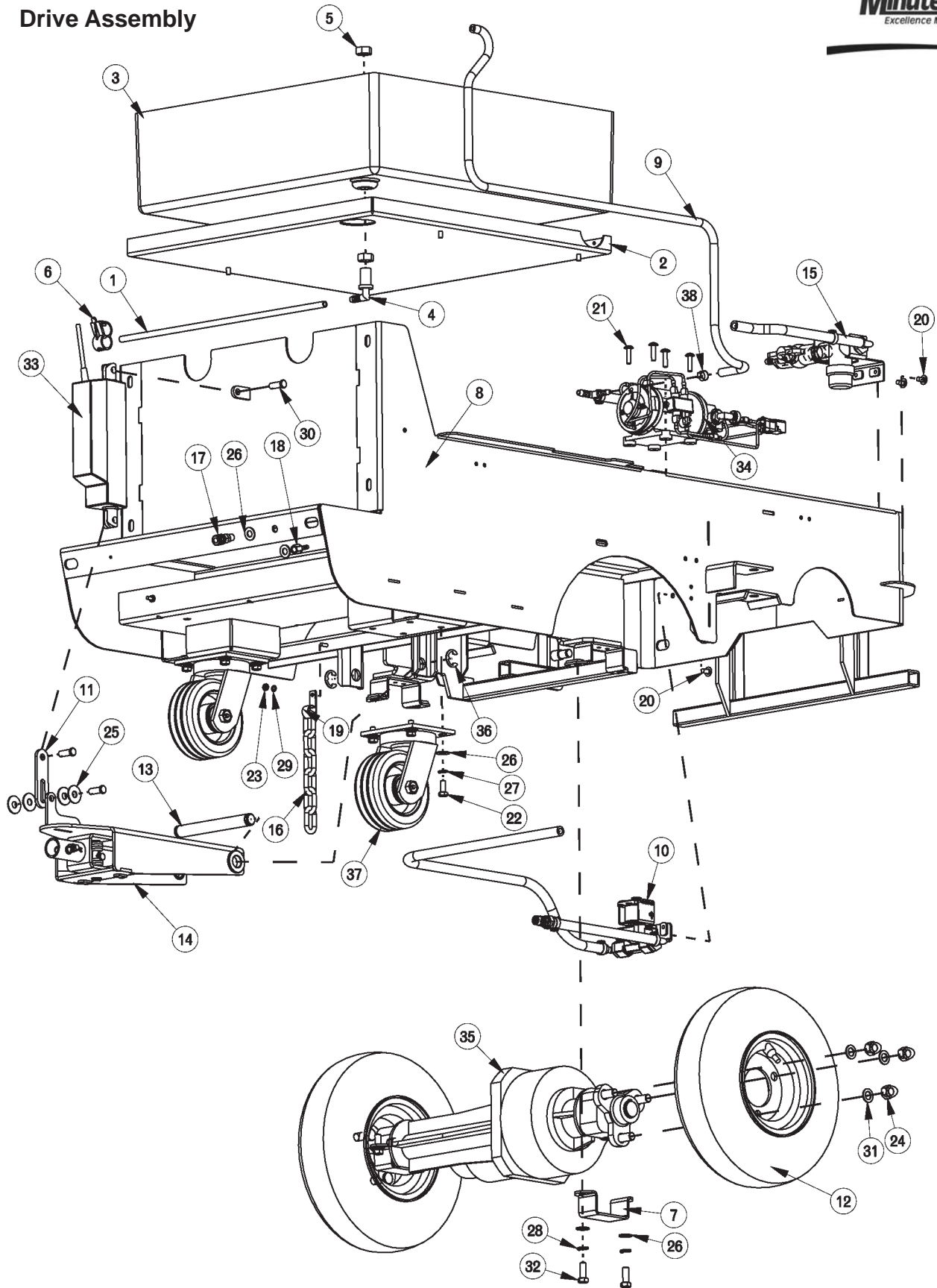

Drive Assembly BOM

BILL OF MATERIAL			
ITEM	PART NO.	REQ'D	DESCRIPTION
1	260224	1	18" HOSE
2	320118	1	BATTERY TRAY
3	320215	1	BATTERY TRAY LINER
4	320271	1	NOZZLE BODY-ELBOW
5	320272	2	NOZZLE BODY LOCKNUT
6	320273	1	HOSE SHUT-OFF CLAMP
7	320705	2	TRANSAXLE BRACKET, LOWER
8	320810	1	MAINFRAME WELDMENT ES2832
9	320834	1	HOSE 1/4" X 36"
10	320843	1	SOLENOID SUB-ASSY COMPLETE, ES2832
11	320893	1	SQUEEGEE LIFT LINK
12	320902	2	WHEEL, PNEUMATIC 12'
13	320909	1	LIFT MECH ASSY PIVOT SHAFT
14	320920	1	SQUEEGEE LIFT MECH ASSY
15	320990	1	IN-LINE FILTER ASSY
16	320996	1	STATIC GROUNDING CHAIN
17	450221	1	Q.C. COUPLING (FEMALE)
18	450225	1	FITTING BRASS 1/8 FPT - 1/4 BARB
19	670115	1	CHAIN MOUNTING STRAP
20	710178	4	SCR-MC 1/4-20 X .50 TRUSS STPL
21	710182	4	SCR-MC 1/4-20 X 1.00 STPL
22	711228	8	BLT-HH 5/16-18 X .75 ST PL
23	711310	2	NUT, HEX 10-32 ST PL
24	711390	6	NUT, ACORN 1/2'-20 STL ZINC
25	711507	4	WSR-FLAT .37 X 1.12 X .06
26	711515	14	WSR-FLAT .406 X .812 X .0625
27	711545	8	WSR-HELICAL 5/16
28	711546	4	WSR-HELICAL 3/8
29	711553	2	WSR- INTERNAL LOCK #10
30	711668	3	CLEVIS PIN, 3/8X1 11-141
31	712310	6	WSR- FLAT .52 X .87 X .06 PL
32	713042	4	BLT-HH 3/8-16 X 1 #5
33	740821-1	1	ACTUATOR ASSEMBLY, LINAK
34	742709-4	1	ES2832 PUMP ASSEMBLY
35	744151	1	TRANSAXLE 18" 36V
36	809148	2	RETAINING RING - "E" TYPE EXT .75
37	827110	2	CASTER 5-INCH
38	828490	1	CRIMP CLAMP 140R

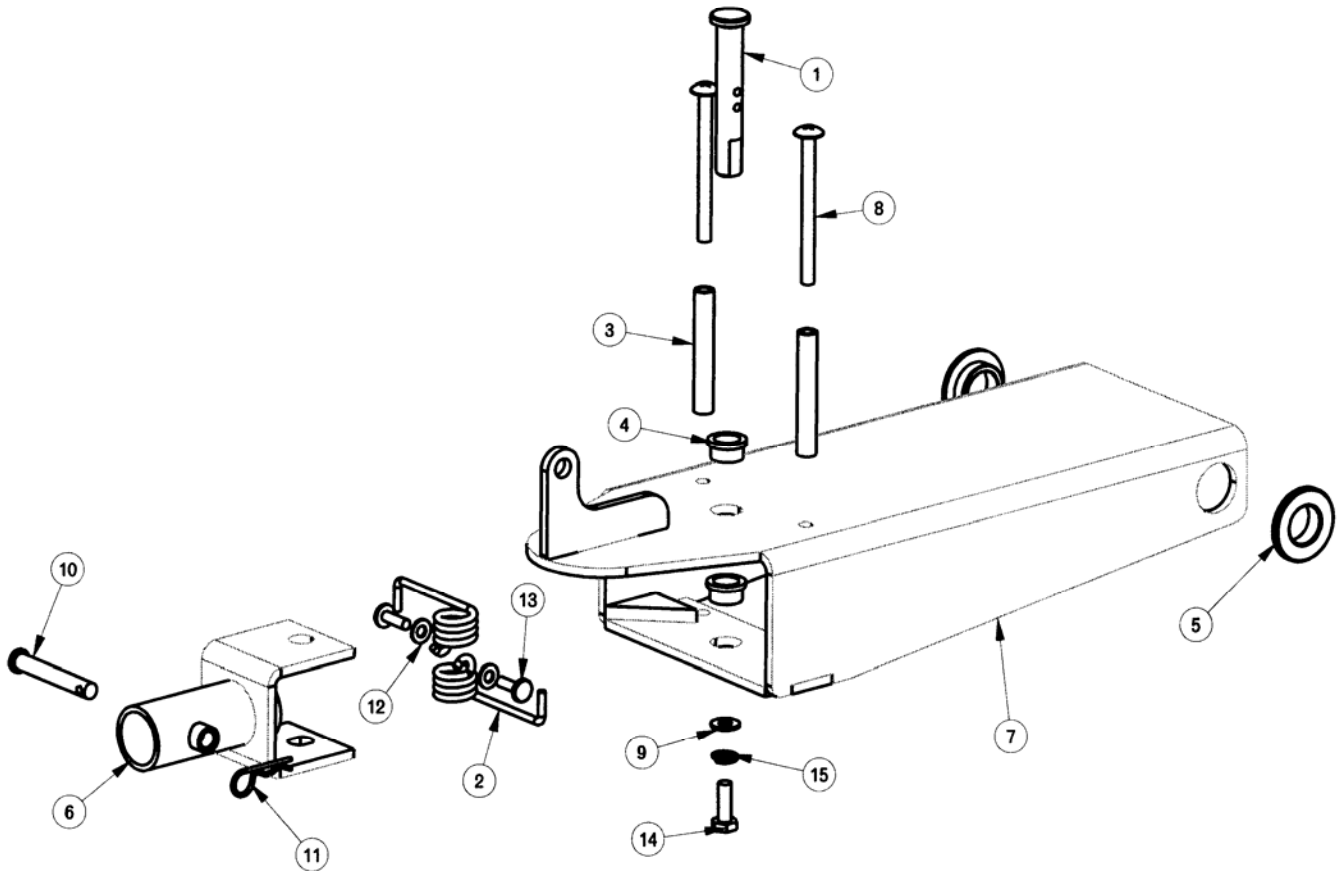

BILL OF MATERIAL - 320920

ITEM	PART NO.	REQ'D	DESCRIPTION
1	210375	1	SWIVEL PIN
2	210391	2	TORSIONAL RETURN SPRING
3	210400	2	SPACER TUBE
4	260041	2	OILITE FLANGE BUSHING
5	320209	2	OILITE FLANGED BEARING
6	320904	1	YOKE WMT, 320 SQUEEGEE MECH
7	320921	1	LIFT MECHANISM WELDMENT
8	710592	2	SCR-MC 1/4-20 X 3.00 SS TH
9	711504	1	WSR-FLAT 1/4 ID SS
10	711671	1	CLEVIS PIN .31X2.13 11-10
11	711808	1	COTTER PIN-HAIR #13
12	712320	2	WSR-NYLON .22 X .45 X .04
13	712536	2	SCR-MC 10-24 X .62 TH SS
14	712562	1	BOLT-HH 1/4-20X3/4 SS
15	712758	1	WSR-HELICAL 1/4 SS

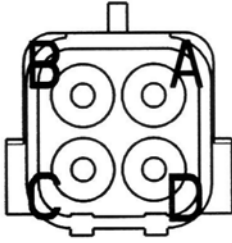

- A- P.N: 748054 VIO/BLACK
- B- P.N: 748053 BLACK/VIO
- C- P.N: 747148-1 GREY/RED
- D- P.N: 747148-2 GREY/BLACK

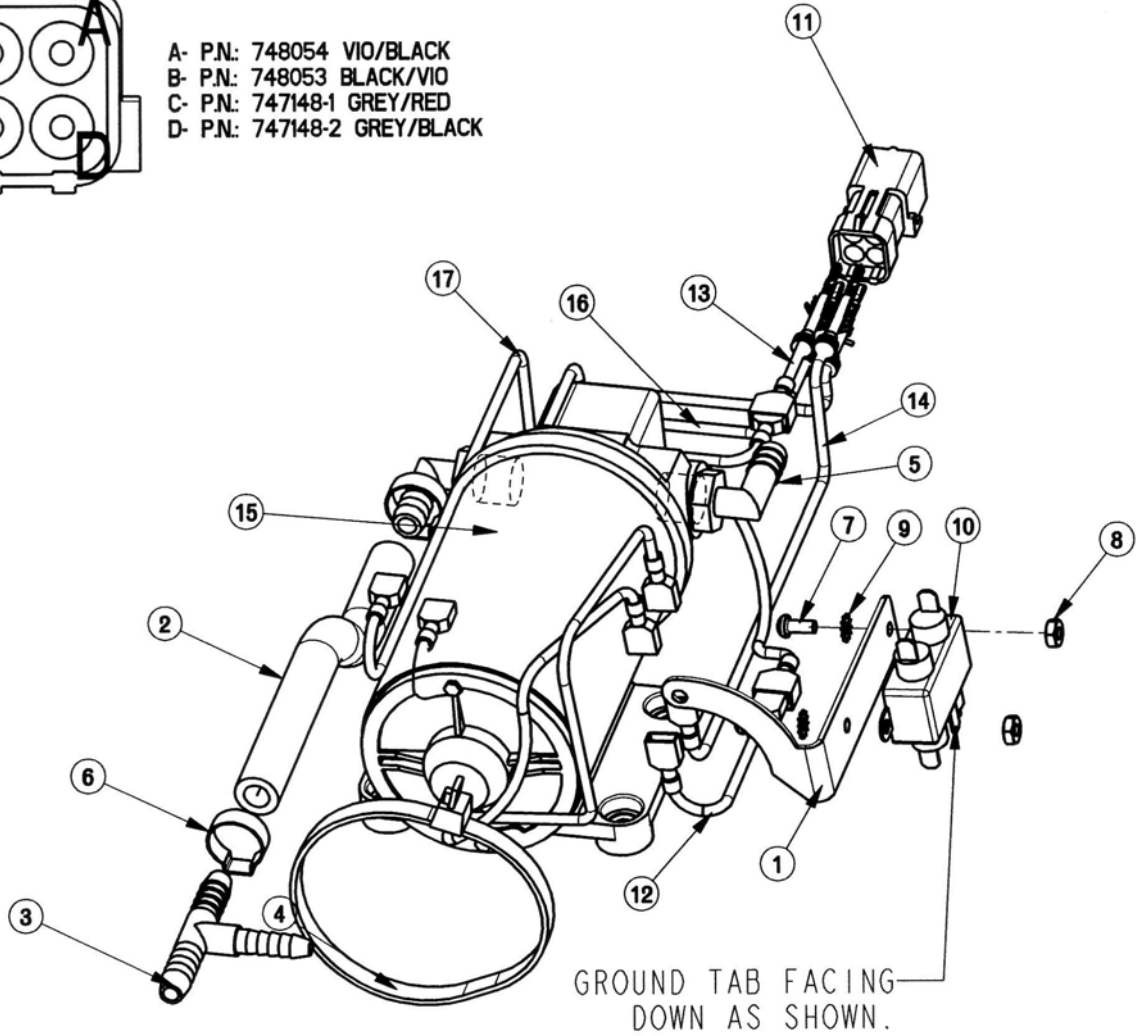

BILL OF MATERIAL - 742709-4

ITEM	PART NO.	REQ'D	DESCRIPTION
1	281414	1	BRACKET-RFI FILTER
2	320842	1	HOSE 3/8 X 8.5"
3	320917	1	FITTING NYLON TEE 3/8X3/8X1/4
4	361218	1	CABLE TIE, BLACK
5	450040	2	FITTING 90 3/8 MPT X 3/8 BARB
6	450076	2	CRIMP CLAMP SS 185R
7	710328	2	SCR-MC 8-32 X .37 ST PL - ROUND HEAD
8	711304	2	NUT-HEX 8-32 ST PL
9	711562	2	WSR-EXTERNAL LOCK #8
10	742391	1	RFI FILTER
11	748029	1	CONNECTOR, PACKARD 4 COND FEMALE
12	748052	1	WIRE ASSY RED 18G 5.5"
13	748053	1	WIRE ASSY BLACK/VIOLET 18G 10"
14	748054	1	WIRE ASSY VIOLET/BLACK 18G 8"
15	742709-3	1	PUMP W/ TERMINALS, SCV
16	747148-1	1	WIRE ASSY GREY/RED 18G 44"
17	747148-2	1	WIRE ASSY GREY/BLACK 18G 44"

In-Line Filter Assembly

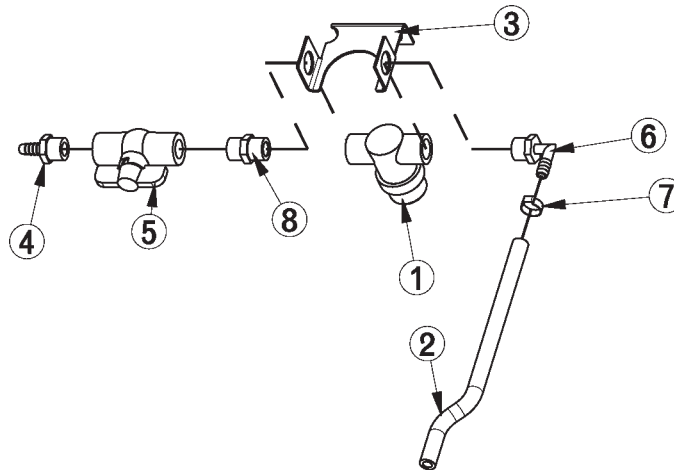

BILL OF MATERIAL - 320990			
ITEM	PART NO.	REQ'D	DESCRIPTION
1	281089	1	FILTER, IN-LINE
2	320848	1	HOSE 3/8 X 12.5"
3	320960	1	PUMP MTG PLATE
4	320991	1	FITTING PP 1/2" MPT X 3/8" HOSE BARB
5	320997	1	BALL VALVE, SHUT OFF 1/2" FPT
6	383327	1	ELBOW 1/2 MPT X 3/8 BARB
7	450076	1	CRIMP CLAMP SS 185R
8	760150	1	FITTING, NIPPLE 1/2" MPT NYLON

Solenoid Assembly

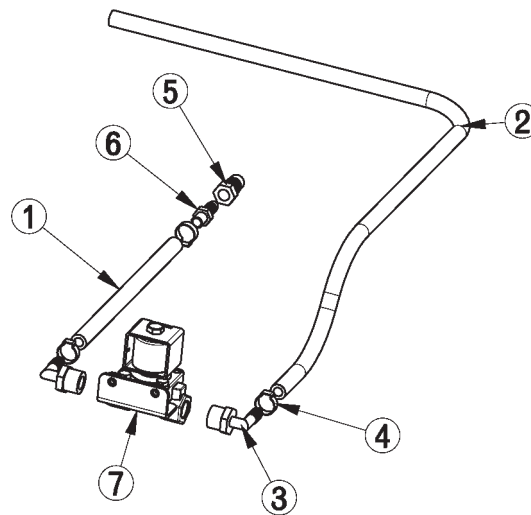

BILL OF MATERIAL - 320843			
ITEM	PART NO.	REQ'D	DESCRIPTION
1	320799	1	ES2832 SPRAY BAR HOSE
2	320845	1	HOSE 3/8 X 35"
3	383327	2	ELBOW 1/2 MPT X 3/8 BARB
4	450076	4	CRIMP CLAMP SS 185R
5	828368	1	MALE COUPLER
6	828952	1	FITTING PP 1/4" MPT X 3/8" HOSE BARB
7	742718-5	1	SOLENOID W/BRACKET, ES2832

Linkage Assembly

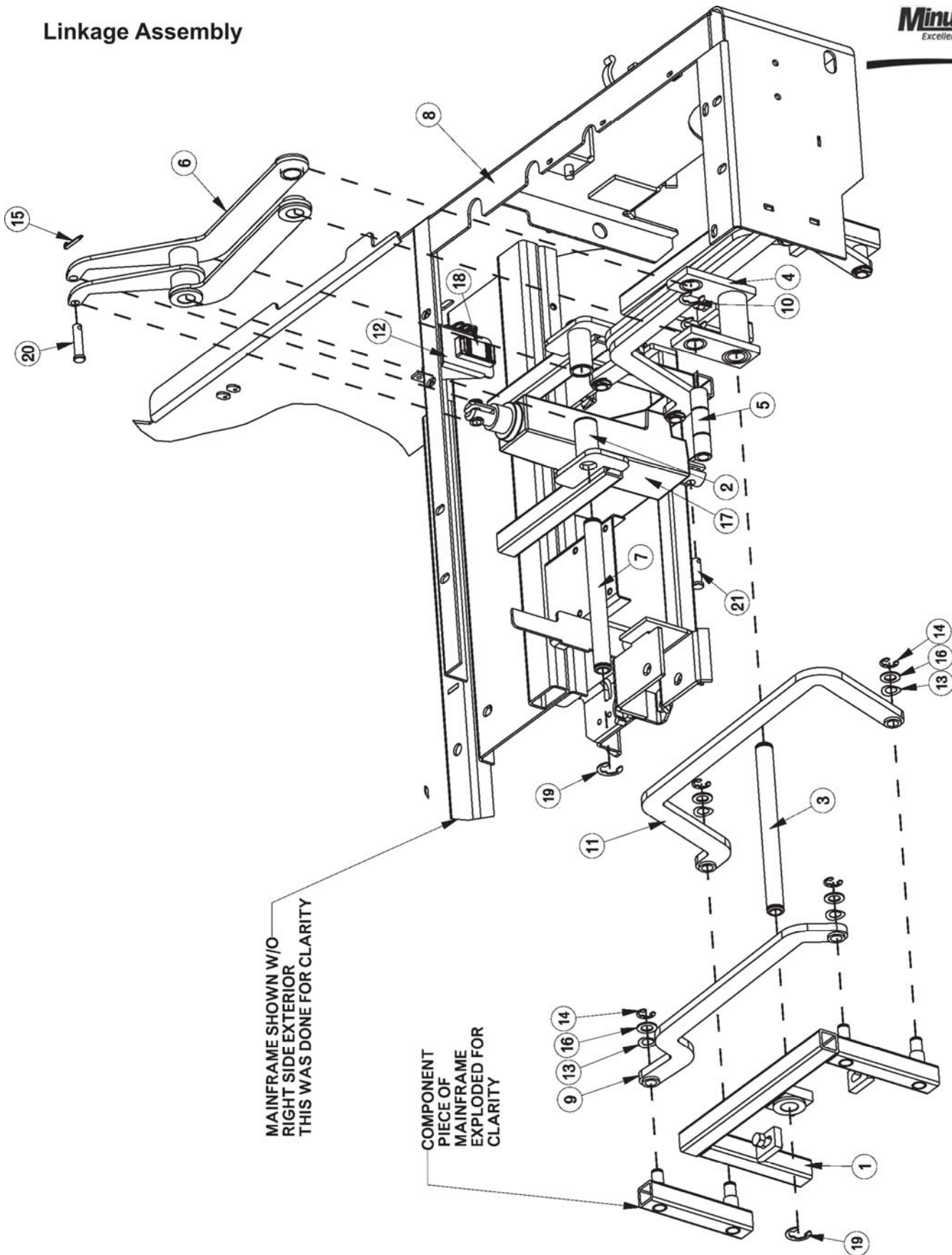

- Item 1 = 281461 left, 281463 right
- Item 9 = 320871 left, 320870 right
- Item 11 = 320873 left, 320872 right

BILL OF MATERIAL			
ITEM	PART NO.	REQ'D	DESCRIPTION
1	281463	1	LIFT WMT RH W/ BUSHING ASS'Y
2	320641	2	TUBE, SPACER FOR LINKAGE, ES2832
3	320786	1	DECK PIVOT SHAFT
4	320793	1	LIFT LINK ASSEMBLY
5	320794	1	LIFT LINK PIN
6	320795	1	LINK ARM ASSEMBLY
7	320796	1	LINKAGE PIVOT SHAFT
8	320810	1	MAINFRAME WELDMENT ES2832
9	320871	1	UPPER LINK ASSY, LH
10	320872	1	LOWER LINK ASSY, RH
11	320873	1	LOWER LINK ASSY, LH
12	320961	1	SWITCH BRK'T ASSY
13	711524	8	WSR-WAVE .52 X .87 X .01
14	711713	8	RETAINING RING - "E" TYPE EXT .500
15	711812	2	COTTER PIN 5/32 X 1.00
16	712310	8	WSR- FLAT .52 X .87 X .06 PL
17	740819	1	ACTUATOR- 2" 900 LBF
18	747023	1	SWITCH, DPST W/3 POS. PACKARD
19	809148	6	RETAINING RING - "E" TYPE EXT .75
20	831965	1	3/8 x 1.63" CLEVIS PIN
21	833833	1	PIN-CLEVIS 3/8 X 1.25

Control Console Assembly

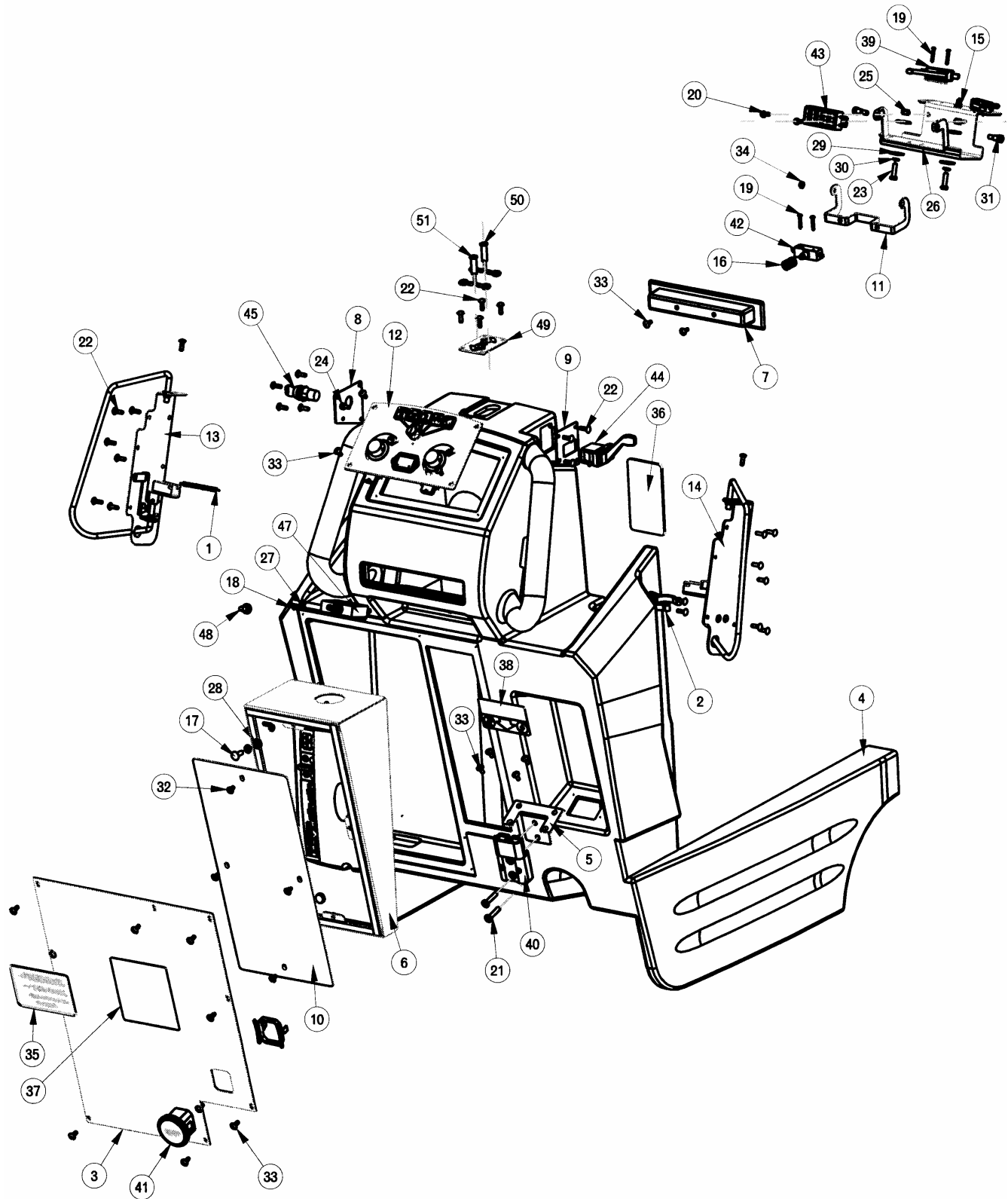

Control Console Assembly BOM

BILL OF MATERIAL - 320823G			
ITEM	PART NO.	REQ'D	DESCRIPTION
1	220324	2	SPRING
2	260579	1	TOOL CLIP, 1.5" HOSE
3	320756	1	ES2832 E-PANEL TOP
4	320823	1	ES2832 CONSOLE
5	320829	1	BRACKET, BATT. PLUG
6	320860	1	ES2832 ELECTRICAL BOX SUB-ASM
7	320896	1	BELLY SWITCH COVER
8	320956	1	KEY SWITCH MNTG PLATE ASSY
9	320957	1	DIRECTIONAL MNTG PLATE ASSY.
10	320965	1	ELECTRICAL BOX COVER
11	320969	1	BAIL BRACKET
12	320970	1	ES2832 DASHBOARD ASM
13	320980	1	ES2832 CONTROL BRKT ASSY LH
14	320982	1	ES2832 CONTROL BRKT RH
15	320986	1	SWITCH BRACKET
16	670093	1	SPRING, COMPRESSION
17	710180	4	SCR-MC TR HD 1/4-20x.75 STL ZINC
18	710203	1	SCR-MC 6-32 X .37 ST PL PAN HD
19	710307	6	SCR-MC 6-32 X .87 ZINC
20	710356	2	SCR-MC 10-32X.62 STPL
21	710383	2	SCR-MC PAN HD 1/4-20 X 1.25 STL
22	711160	28	#10 X 5/8 HI-LO
23	711206	2	BLT-HH 1/4-20 X .87 ST PL
24	711310	7	NUT, HEX 10-32 ST PL
25	711373	2	NUT-NYLOC 1/4-20
26	711430	1	NUT-TINNERMAN TWIN 6-32
27	711502	1	WSR-FLT .170 x.38 x.032 STL ZINC
28	711505	4	WSR-FLAT 1/4
29	711519	4	WSR- FLAT .25 X 1.01 X .06
30	711544	6	WSR-HELICAL 1/4
31	711553	9	WSR- INTERNAL LOCK #10
32	712041	2	BLT- SHLDR 1/4-20 X .44 X .37
33	712540	4	SCR-MC TR HD 10-24 X .37 SS
34	712822	10	SCR-MC TR HD 10-24 X .50 SS
35	712900	2	NUT-HEX 10-24 STPL
36	715619	1	DECAL, WARNING
37	715628	1	DECAL, BATTERY
38	715904	1	DECAL, DIAGNOSTIC CODES
39	715905	1	DECAL, EMERGENCY DISCONNECT
40	740128	2	SWITCH, SNAP SPST NC
41	740147	1	CB 175 GRAY HOUSING
42	740539	1	HOUR METER 10 - 80 VDC
43	742472	1	SWITCH
44	744005	1	TERMINAL BLOCK EAGLE 3
45	747024	1	KEYSWITCH, SPST ES2832 SOLDER
46	747100	1	ES2832 MAIN WIRE HARNESS
47	748012	1	CIRCUIT BREAKER 100A
48	748032	1	CIRCUIT BREAKER, BOOT FOR 748012
49	320958SP	1	DIRECTIONAL INDICATOR PLATE (SP)
50	747016-1	1	LED ASSY7 RED
51	747017-1	1	LED ASSY AMBER

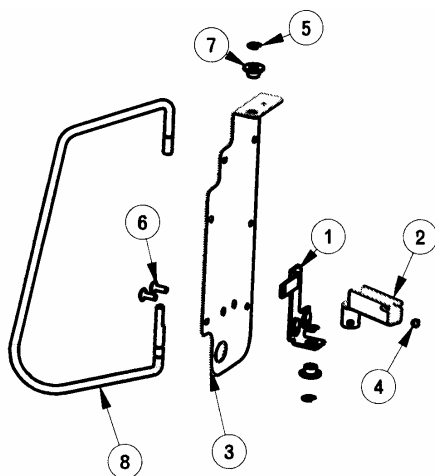

BILL OF MATERIAL - 320980			
ITEM	PART NO.	REQ'D	DESCRIPTION
1	320821	1	ES2832 CONTROL ARM BRKT ASSY LH
2	320825	1	CAM WELDMENT
3	320979	1	ES2832 CONTROL BRKT LH
4	711004	1	SK-CUP PT 1/4-20 X .25 STL BLACK
5	711721	3	RET RING-E TYPE .312
6	712822	2	SCR-MC TR HD 10-24 X .50 SS
7	829052	2	BUSHING FLANGED NYLON .312 ID
8	200181CTD	1	HANDLE WIRE COATED

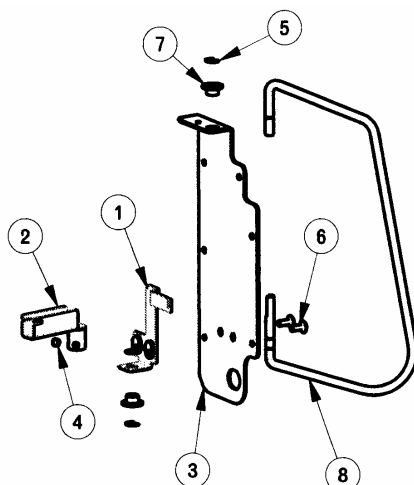

BILL OF MATERIAL - 320982			
ITEM	PART NO.	REQ'D	DESCRIPTION
1	320822	1	ES2832 CONTROL ARM BRKT ASSY RH
2	320825	1	CAM WELDMENT
3	320981	1	ES2832 CONTROL BRKT RH
4	711004	1	SK-CUP PT 1/4-20 X .25 STL BLACK
5	711721	3	RET RING-E TYPE .312
6	712822	2	SCR-MC TR HD 10-24 X .50 SS
7	829052	2	BUSHING FLANGED NYLON .312 ID
8	200181CTD	1	HANDLE WIRE COATED

Electric Box Assembly

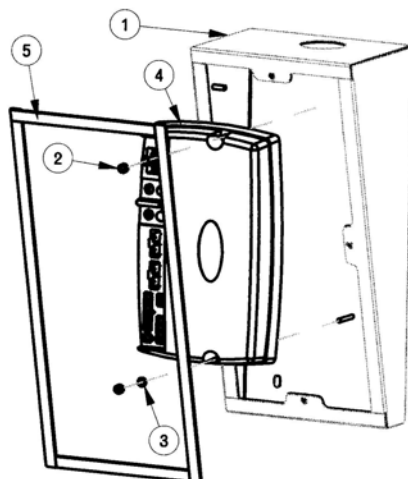

BILL OF MATERIAL - 320860			
ITEM	PART NO.	REQ'D	DESCRIPTION
1	320861	1	ELECTRICAL BOX BASE
2	711372	2	NUT-NYLOC 8-32 STL ZINC
3	711502	2	WSR-FLT .170 x.38 x.032 STL ZINC
4	747010	1	CONTROLLER-TRIO PLUS 36 VDC 50A
5	830557	3.75FT	DORTITE 1/2" RM 1F

Dashboard Assembly

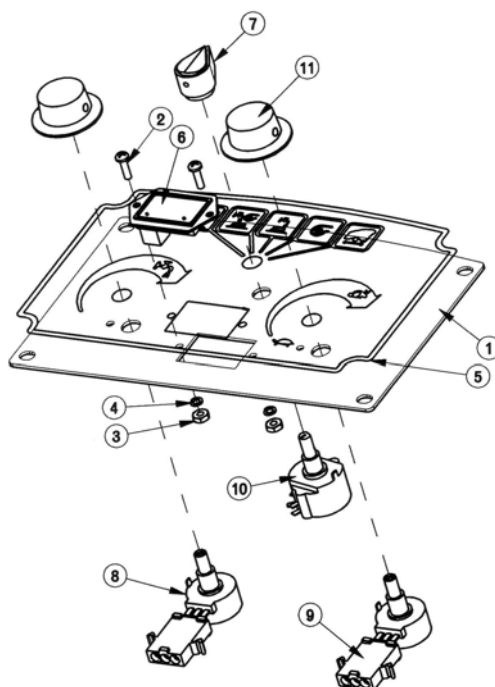

BILL OF MATERIAL - 320970			
ITEM	PART NO.	REQ'D	DESCRIPTION
1	320866	1	CONTROL PANEL PLATE ASSY
2	710204	2	SCR-MC 6-32 X .50 ST PL PAN HD
3	711301	2	NUT-HEX 6-32 ST PL
4	711541	2	WSR-HELICAL #6 ST PL
5	715753	1	DECAL, ES2832 DASHBOARD
6	747011-1	1	BATT GAUGE ASSY TRUE CHARGE 36V
7	747020	1	KNOB-MODE SELECTOR
8	747025	1	POTENTIOMETER ASSY WATER FLOW
9	747026	1	POTENTIOMETER ASSY SPEED CONTROL
10	747027	1	SWITCH ASSY, MODE SELECTOR
11	809874	2	KNOB, SPEED CONTROL

Solution Tank Assembly

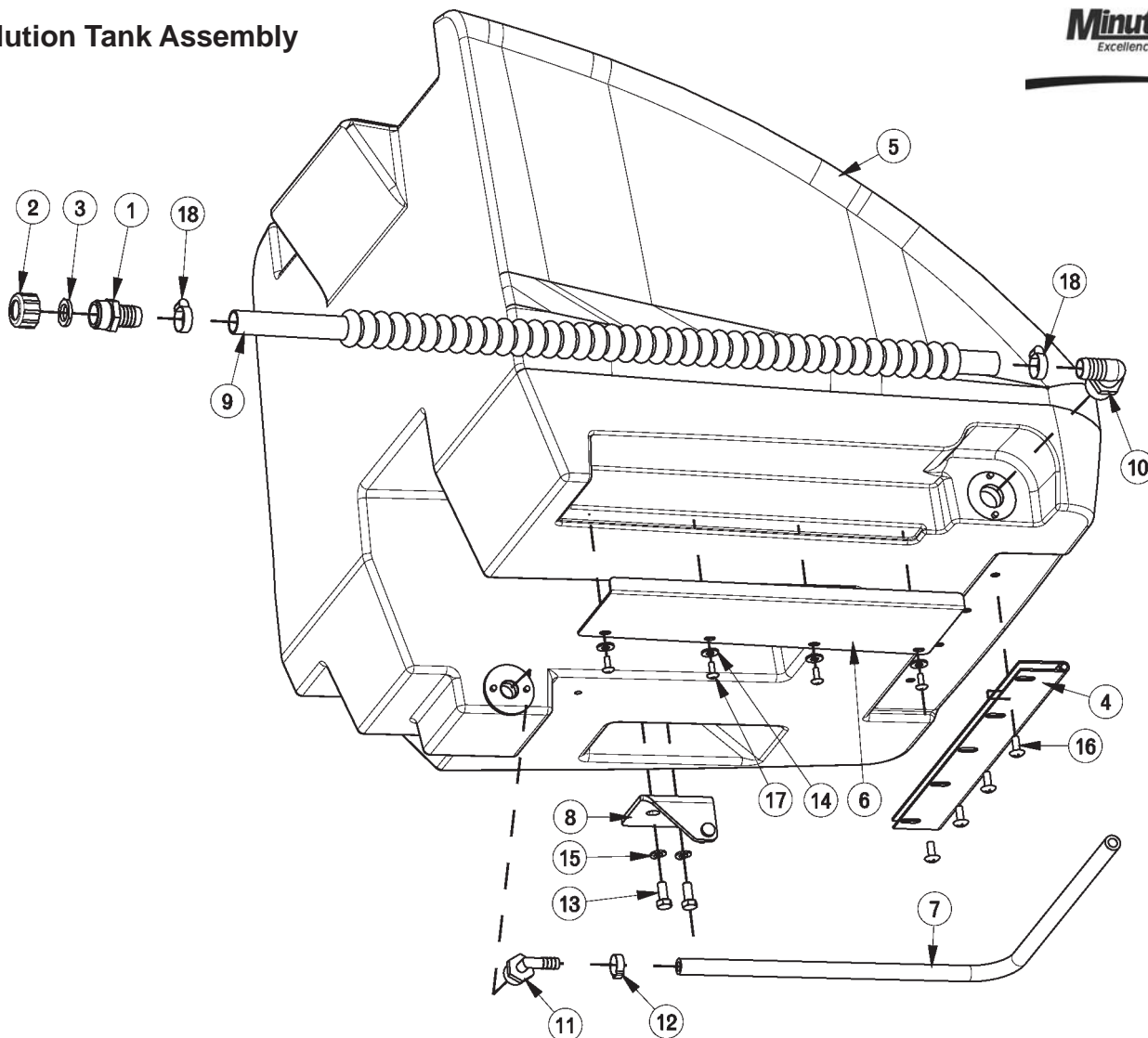

BILL OF MATERIAL - 320840

ITEM	PART NO.	REQ'D	DESCRIPTION
1	200022	1	3/4" MGHT X HOSE BARB
2	200023	1	GARDEN HOSE CAP
3	200024	1	BLACK VINYL WASHER
4	260087	1	HINGE 15"
5	320841	1	ES2832 SOLUTION TANK
6	320844	1	DUMP HOSE SUPPORT PLATE
7	320846	1	HOSE 3/8" X 22"
8	320914	1	SOLUTION TANK BRKT WMT
9	320964	1	SOLUTION DRAIN HOSE 3/4" X 31"
10	383321	1	FITTING PP 90 3/4 MPT 3/4 BARB
11	383327	1	ELBOW 1/2 MPT X 3/8 BARB
12	450076	1	CRIMP CLAMP SS 185R
13	711228	2	BLT-HH 5/16-18 X .75 ST PL
14	711505	4	WSR-FLAT 1/4
15	711545	2	WSR-HELICAL 5/16
16	712565	4	SCR-MC 1/4-20X.63 SS TR HD
17	712822	4	SCR-MC TR HD 10-24 X .50 SS
18	829129	2	HOSE CLAMP MICRO-SEAL

Recovery Tank Assembly

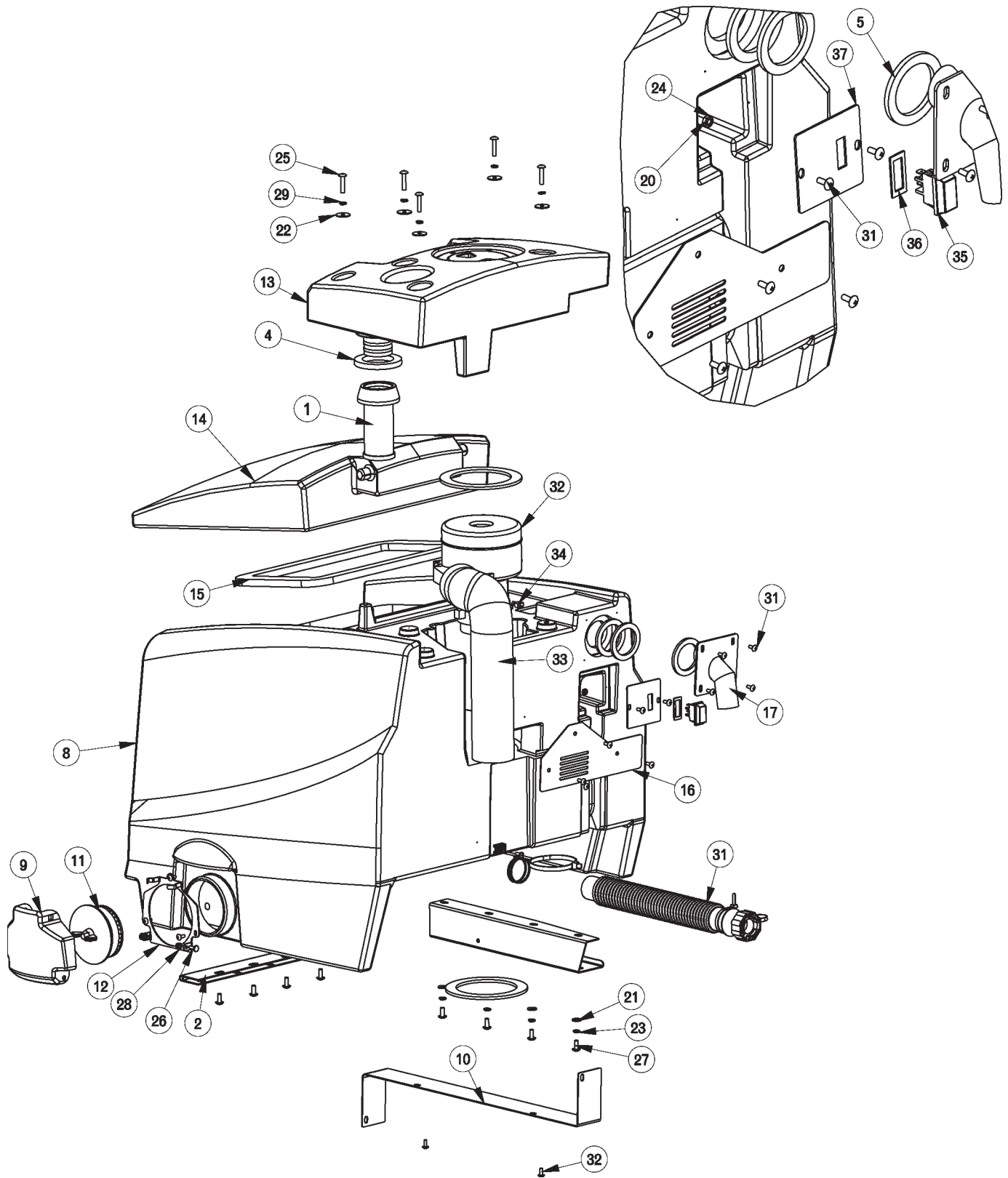

BILL OF MATERIAL - 320830			
ITEM	PART NO.	REQ'D	DESCRIPTION
1	241060	1	SCREENED FLOAT
2	260087	1	HINGE 15"
3	260203	1	WIRE GRIP HOSE CLAMP
4	281073	1	INLET GASKET
5	281950	3	FLOAT CAGE GASKET
6	320740	1	DUMP HOSE COMPLETE
7	320754	1	HOSE SUPPORT BRACKET, ES2832
8	320831	1	ES2832 RECOVERY TANK
9	320835	1	ES2832 DUMP CAP COVER
10	320837	1	RETAINER - LARGE
11	320838	1	STOPPER PLUG ASM - 4"
12	320839	1	DUMP COVER SUPPORT RING
13	320850	1	ES2832 FIXED LID ASSY
14	320855	1	ES2832 MOVABLE LID
15	320856	1	ES2832 GASKET, MOVABLE LID
16	320967	1	VAC MOTOR VENT COVER
17	320987	1	INLET PIPE ASSY ES2832
18	361218	1	CABLE TIE, BLACK
19	380035	1	MOTOR GASKET
20	711310	1	NUT, HEX 10-32 ST PL
21	711505	4	WSR-FLAT 1/4
22	711519	5	WSR- FLAT .25 X 1.01 X .06
23	711544	4	WSR-HELICAL 1/4
24	711553	1	WSR- INTERNAL LOCK #10
25	712138	5	SCR-MC 1/4-20 X 1.25 TRUSS PL SS
26	712536	2	SCR-MC 10-24 X .62 TH SS
27	712565	8	SCR-MC 1/4-20X.63 SS TR HD
28	712638	2	NUT, HEX 10-24 SS NYLOC
29	712758	5	WSR-HELICAL 1/4 SS
30	712811	1	SCR-MC RD HD 10-24 X .50 ST PL
31	712822	16	SCR-MC TR HD 10-24 X .50 SS
32	828064	1	CABLE TIE MOUNT, BLACK
31	200289	1	DUMP HOSE ASSY
32	742772-1	1	VACUUM ASSY
33	760859	1	CLAMP, HOSE
34	320836	1	MUFFLER, VAC MOTOR
35	742716	1	SWITCH DREEFS 1 POLE ON-OFF
36	748035	1	ROCKER SWITCH GASKET
37	320828	1	HOSE FITTING PLATE ASSY.

Fixed Lid Assembly

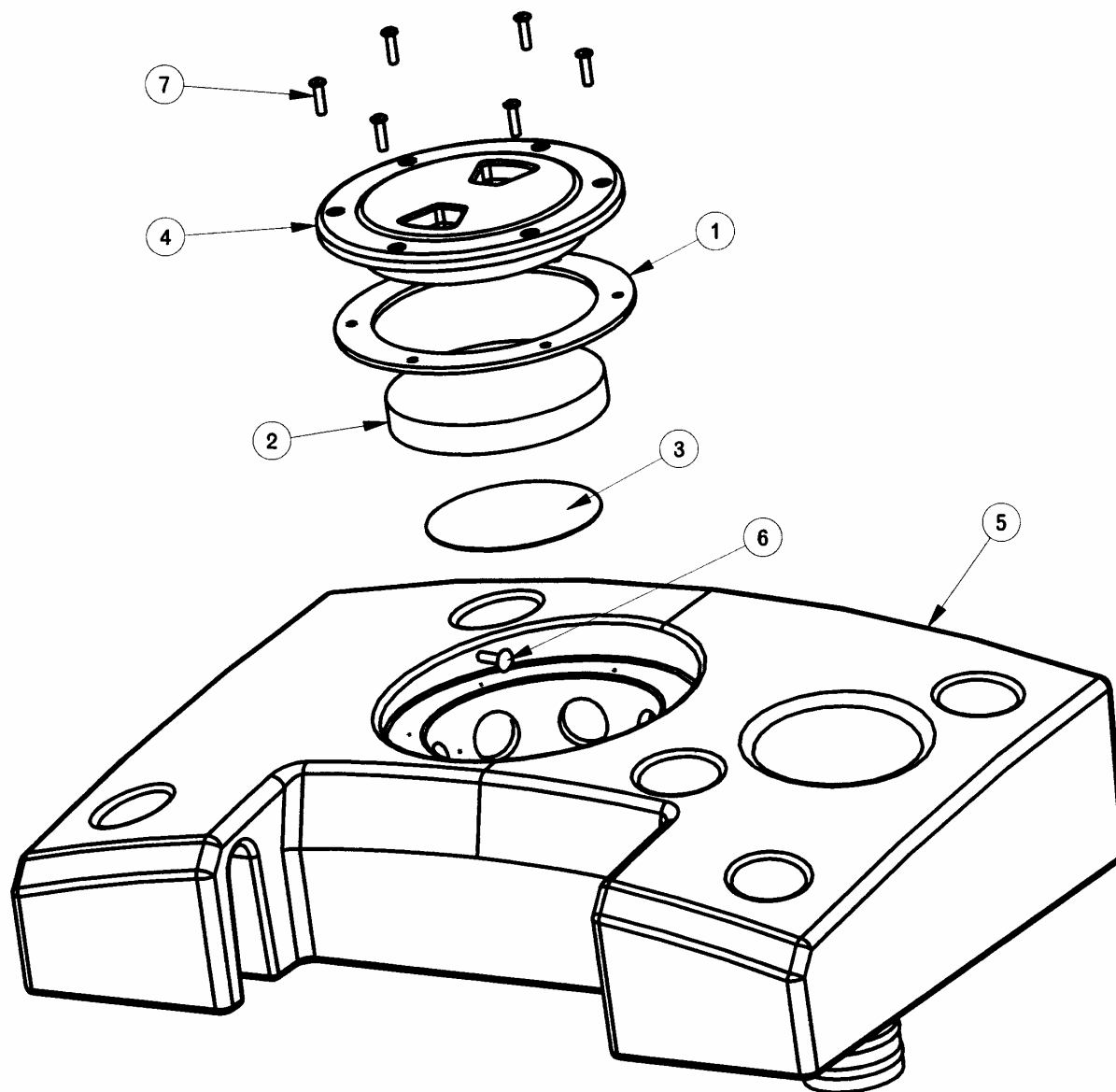

BILL OF MATERIAL - 320850			
ITEM	PART NO.	REQ'D	DESCRIPTION
1	281018	1	GASKET, NEO 6.00 X 4.50 X .125
2	281055	1	VAC MOTOR FILTER
3	281056	1	VAC MOTOR INLET SCREEN
4	281423	1	FILL CAP W/CHAIN ASSY 4.00
5	320851	1	ES2832 FIXED LID
6	380035	1	MOTOR GASKET
7	711160	1	#10 X 5/8 HI-LO
8	712516	6	SCR-BHCS #8-32 x .62 SS

28" Cylindrical Scrub Deck Assembly

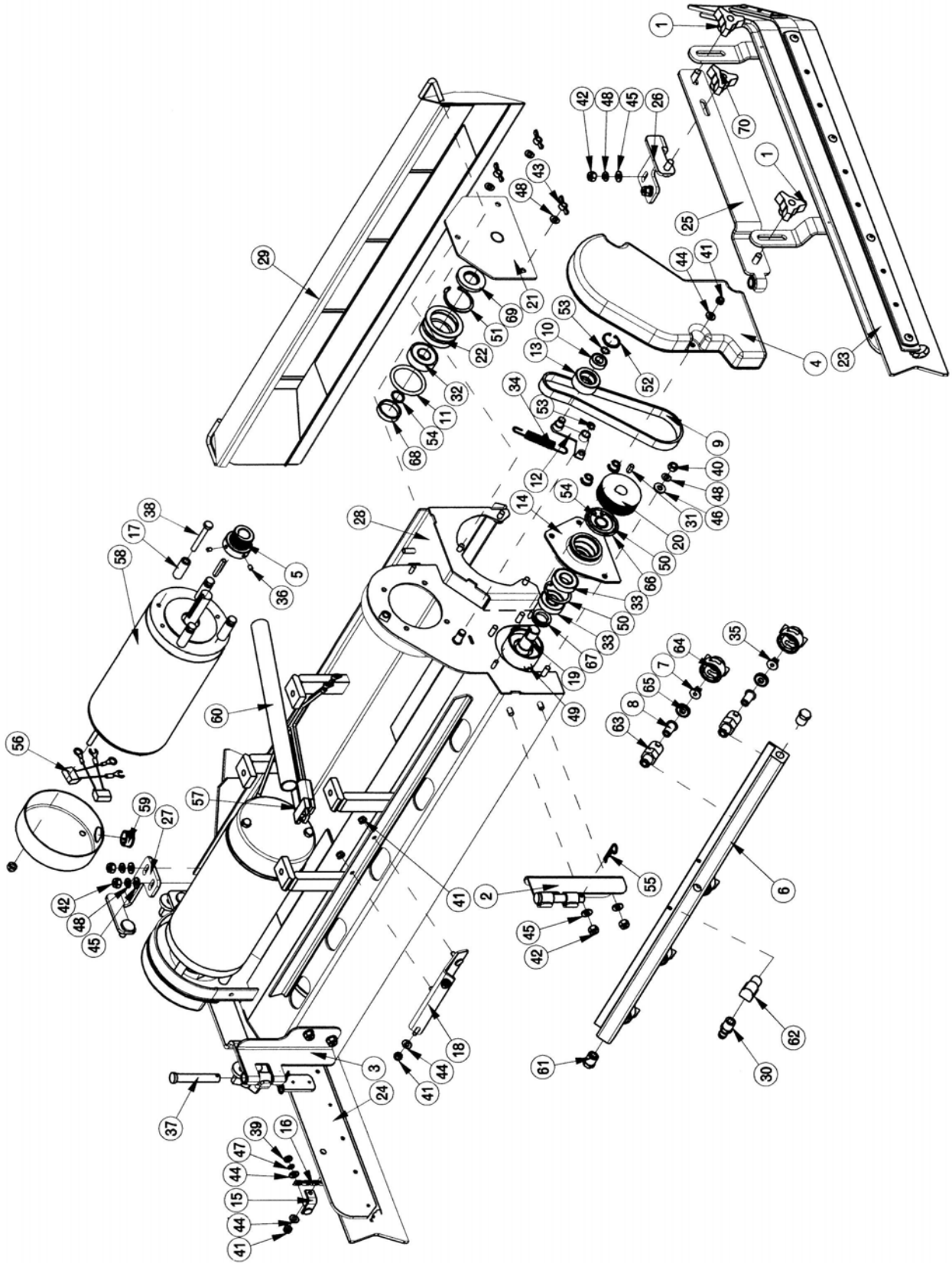

28" Cylindrical Scrub Deck Assembly BOM

BILL OF MATERIAL - 281501

ITEM	PART NO.	REQ'D	DESCRIPTION	ITEM	PART NO.	REQ'D	DESCRIPTION
1	210118	4	KNOB-3 SIDED 5/16 NYLOC	36	711003	8	SCR-SK 10-32 x .25
2	241544	1	HINGE BRKT WLDMNT RH, SCV2426	37	711119	2	CLEVIS PIN 7/16 X2-5/8
3	241546	1	HINGE BRKT WLDMNT LH,SCV2426	38	711214	8	BLT-HH 1/4-20 X 2.00
4	281023	2	BELT COVER, CYLINDRICAL SCRUBDECK	39	711310	1	NUT, HEX 10-32 ST PL
5	281036	2	OFFSET PULLEY POLY V	40	711316	8	NUT-HEX 1/4-20 ST PL
6	281038	1	SPRAY BAR	41	711350	10	NUT NYLOC 10-32
7	281040	3	SPRAY TIP 11005	42	711373	8	NUT-NYLOC 1/4-20
8	281041	5	CHECK VALVE	43	711389	6	NUT-WING 1/4-20 STL ZINC
9	281053	2	J BELT (POLY V) 18"	44	711503	9	WSR, FLAT#10
10	281058	2	BEARING 3/8" RADIAL	45	711504	8	WSR-FLAT 1/4 ID SS
11	281519	2	O-RING 1.62 X 2.00 X .188	46	711505	6	WSR-FLAT 1/4
12	281544	2	TENSIONER ARM WELDMT	47	711543	1	WSR - HELICAL #10
13	281548	2	BELT IDLER	48	711544	16	WSR-HELICAL 1/4
14	281550	2	BEARING HOUSING, CYL SCRUBDECK	49	711676	4	ROLL PIN, 3/8 x 3/4
15	281557	1	DRAG CHAIN BRKT, CYL. SCRUBDECK	50	711701	4	RETAINING RING, INT 1.37
16	281558	1	DRAG CHAIN, CYL. SCRUBDECK	51	711702	2	RETAINING RING, INT 1.62
17	281598	8	MOTOR STANDOFF - CYL SCRUB DECK	52	711704	2	INT RETAINING RING N5000-86 .875 DIA.
18	281606	1	SPRAY HEAD MTG BRKT	53	711724	4	3/8" RETAINING RING, EXTERNAL
19	281675	2	DRIVE HUB, CYL SCRUBDECK	54	711725	4	5/8" RETAINING RING, EXTERNAL
20	281676	2	DRIVEN PULLEY, CYL SCRUBDECK	55	711808	2	COTTER PIN-HAIR #13
21	281681	2	IDLE SHAFT WMT, CYL DECK	56	744016-1	4	CAP .15 MICROFARAD 5/16R-1/4FORK
22	281684	2	IDLE HUB, CYL SCRUBDECK	57	748046	1	WIRE ASSY. BRUSH DECK CYLINDER
23	281851	1	SIDE SQUEEGEE WIPE ASSY LH, SCV 28/32	58	748048	2	MOTOR 1 HP, 36V, 1800RPM
24	281857	1	SIDE SQUEEGEE WIPE ASSY RH, SCV 28/32	59	748122	2	BUSHING, HEYCO 2103 I.D .625.
25	281866	2	UPPER SQUEE BRKT WMT, SCV 28/32	60	748141	1	CABLE WRAP, 11"
26	281868	1	CYL. DECK SIDE SQUEE SUPPORT LH	61	829619	2	END PLUG
27	281869	1	CYL. DECK SIDE SQUEE SUPPORT RH	62	831306	1	FITTING 90 STREET BRASS 1/4x1/4
28	281832	1	28" CYLINDRICAL SCRUBDECK WELDMNT	63	833140	5	BODY INLET CONNECTOR
29	281901	1	DEBRIS BOX WMT, CYL SCRUBDECK 28"	64	833141	5	CAP
30	320264	1	FITTING BRASS - 3/8 DBL BARB X 1/4MPT	65	833142	5	GASKET CAP
31	361252	2	KEY, WOODRUFF, 3/16 SQ X .5	66	833603	2	O RING, 1 11/16 x 1 7/8, AS568A-131
32	383551	2	BEARING, RADIAL 5/8" 6203	67	833605	2	VRING SEAL
33	383558	4	BEARING, RADIAL 5/8" R10	68	833611	2	END CAP
34	430051	2	RETURN SPRING-3.00"	69	833612	2	RADIAL SHAFT SEAL
35	450122	2	UNIJET SPRAY TIP 6503	70	210118Y	2	KNOB-3 SIDED 5/16 NYLOC YELLOW

32" Cylindrical Scrub Deck Assembly

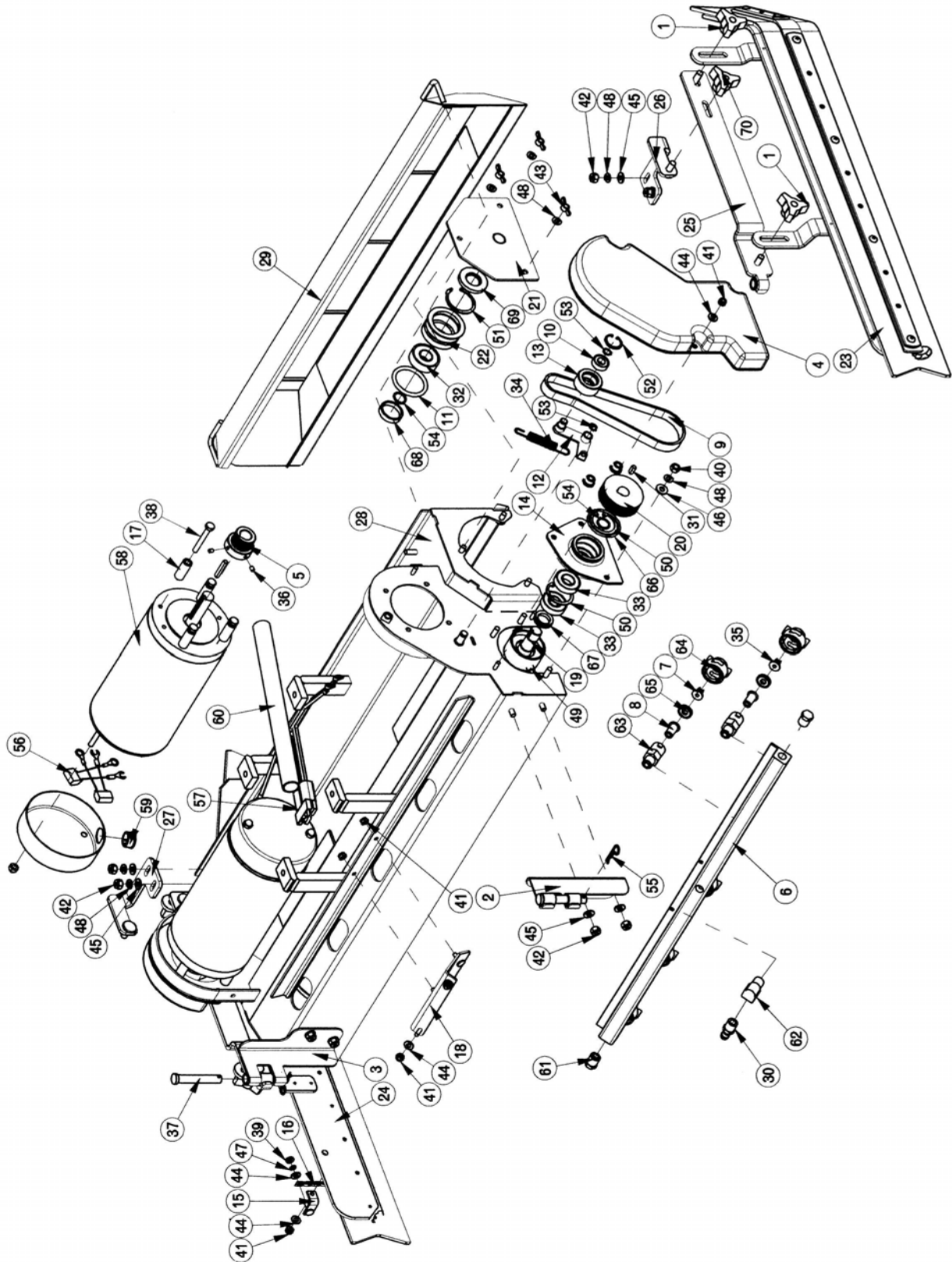

32" Cylindrical Scrub Deck Assembly BOM



BILL OF MATERIAL - 281551							
ITEM	PART NO.	REQ'D	DESCRIPTION	ITEM	PART NO.	REQ'D	DESCRIPTION
1	210118	4	KNOB-3 SIDED 5/16 NYLOC	36	711003	8	SCR-SK 10-32 x .25
2	241544	1	HINGE BRKT WLDMNT RH, SCV2426	37	711119	2	CLEVIS PIN 7/16 X 2-5/8
3	241546	1	HINGE BRKT WLDMNT LH, SCV2426	38	711214	8	BLT-HH 1/4-20 X 2.00
4	281023	2	BELT COVER, CYLINDRICAL SCRUBDECK	39	711310	1	NUT, HEX 10-32 ST PL
5	281036	2	OFFSET PULLEY POLY V	40	711316	8	NUT-HEX 1/4-20 ST PL
6	281038	1	SPRAY BAR	41	711350	10	NUT NYLOC 10-32
7	281040	3	SPRAY TIP 11005	42	711373	8	NUT-NYLOC 1/4-20
8	281041	5	CHECK VALVE	43	711389	6	NUT-WING 1/4-20 STL ZINC
9	281053	2	J BELT (POLY V) 18"	44	711503	9	WSR, FLAT#10
10	281058	2	BEARING 3/8" RADIAL	45	711504	8	WSR-FLAT 1/4 ID SS
11	281519	2	O-RING 1.62 X 2.00 X .188	46	711505	6	WSR-FLAT 1/4
12	281544	2	TENSIONER ARM WELDMT	47	711543	1	WSR - HELICAL #10
13	281548	2	BELT IDLER	48	711544	16	WSR-HELICAL 1/4
14	281550	2	BEARING HOUSING, CYL SCRUBDECK	49	711676	4	ROLL PIN, 3/8 x 3/4
15	281557	1	DRAG CHAIN BRKT, CYL. SCRUBDECK	50	711701	4	RETAINING RING, INT 1.37
16	281558	1	DRAG CHAIN, CYL. SCRUBDECK	51	711702	2	RETAINING RING, INT 1.62
17	281598	8	MOTOR STANDOFF - CYL SCRUB DECK	52	711704	2	INT RETAINING RING N5000-86 .875 DIA.
18	281606	1	SPRAY HEAD MTG BRKT	53	711724	4	3/8" RETAINING RING, EXTERNAL
19	281675	2	DRIVE HUB, CYL SCRUBDECK	54	711725	4	5/8" RETAINING RING, EXTERNAL
20	281676	2	DRIVEN PULLEY, CYL SCRUBDECK	55	711808	2	COTTER PIN-HAIR #13
21	281681	2	IDLE SHAFT WMT, CYL DECK	56	744016-1	4	CAP .15 MICROFARAD 5/16R-1/4FORK
22	281684	2	IDLE HUB, CYL SCRUBDECK	57	748046	1	WIRE ASSY, BRUSH DECK CYLINDER
23	281851	1	SIDE SQUEEGEE WIPE ASSY LH, SCV 28/32	58	748048	2	MOTOR 1 HP, 36V, 1800RPM
24	281857	1	SIDE SQUEEGEE WIPE ASSY RH, SCV 28/32	59	748122	2	BUSHING, HEYCO 2103 I.D .625.
25	281866	2	UPPER SQUEE BRKT WMT, SCV 28/32	60	748141	1	CABLE WRAP, 11"
26	281868	1	CYL. DECK SIDE SQUEE SUPPORT LH	61	829619	2	END PLUG
27	281869	1	CYL. DECK SIDE SQUEE SUPPORT RH	62	831306	1	FITTING 90 STREET BRASS 1/4x1/4
28	281892	1	32" CYLINDRICAL SCRUBDECK WELDMNT	63	833140	5	BODY INLET CONNECTOR
29	281906	1	DEBRIS BOX WMT, CYL SCRUBDECK 32"	64	833141	5	CAP
30	320264	1	FITTING BRASS - 3/8 DBL BARB X 1/4MPT	65	833142	5	GASKET CAP
31	361252	2	KEY, WOODRUFF, 3/16 SQ X .5	66	833603	2	O RING, 1 1/16 x 1 7/8, AS568A-131
32	383551	2	BEARING, RADIAL 5/8" 6203	67	833605	2	V RING SEAL
33	383558	4	BEARING, RADIAL 5/8" R10	68	833611	2	END CAP
34	430051	2	RETURN SPRING-3.00"	69	833612	2	RADIAL SHAFT SEAL
35	450122	2	UNIJET SPRAY TIP 6503	70	210118Y	2	KNOB-3 SIDED 5/16 NYLOC YELLOW

28" Disc Scrub Deck Assembly

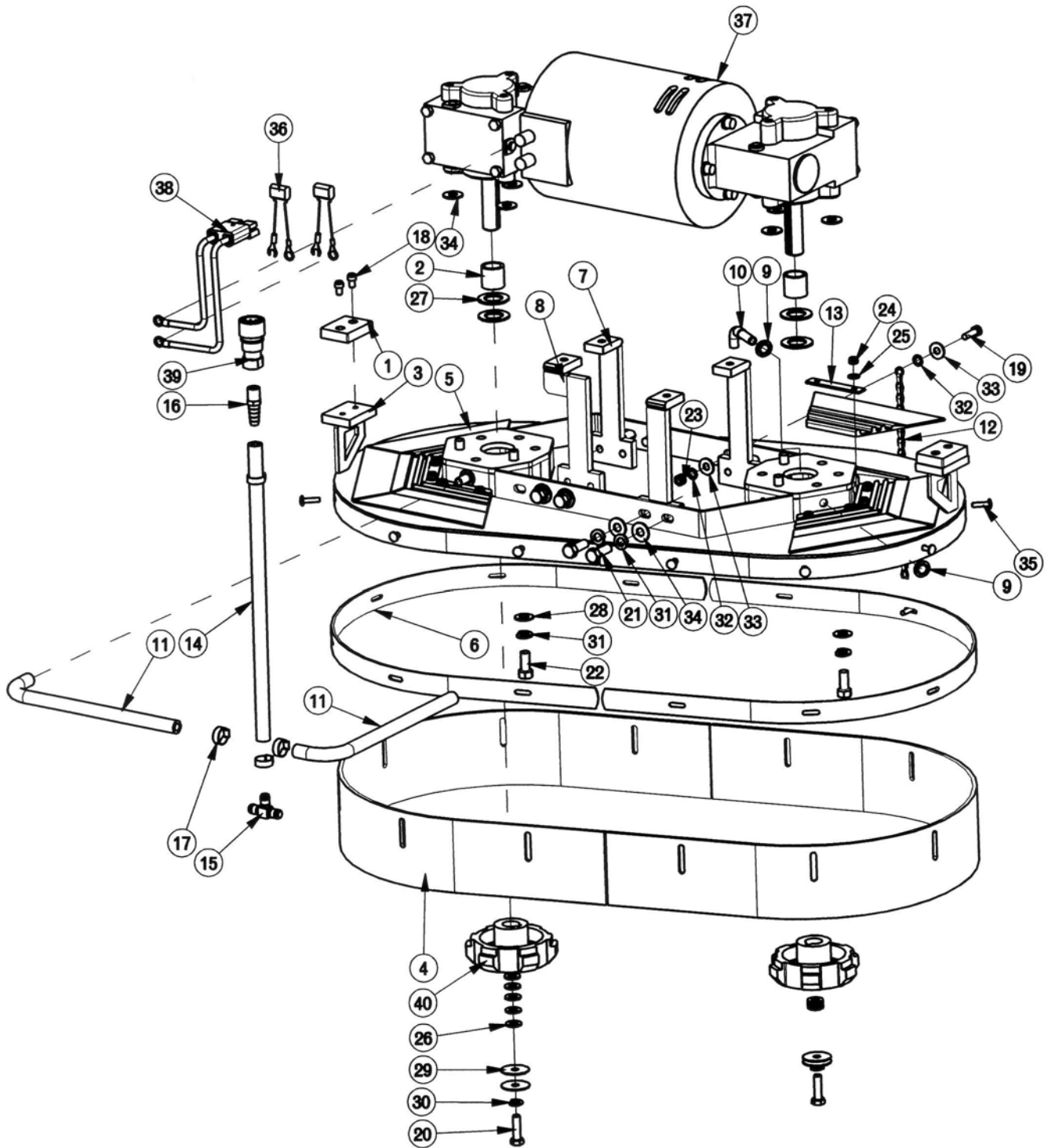

28" Disc Scrub Deck Assembly BOM

BILL OF MATERIAL - 281601			
ITEM	PART NO.	REQ'D	DESCRIPTION
1	281515	2	WEAR PLATE
2	281611	2	HUB-SCRUB SPACER TUBE
3	281612	1	DISK SCRUBDECK WMT, 28"
4	281613	2	SKIRT, 28" DISK
5	281614	6	FLAP, DISK
6	281615	2	STRAP, DISK
7	281616	3	DISK MTG BRKT WMT
8	281617	1	DISK OFFSET MTG BRKT WMT
9	281633	4	SPEED NUT - 3/8"
10	281634	2	DISK SOLUTION FEED ASSY
11	281637	4	SOL. FEED END HOSE
12	281644	1	DRAG CHAIN ASSY, DISK SCRUBDECK
13	281660	6	STRAP, KEEPER
14	320253	1	HOSE, SOLUTION VALVE 14"
15	320266	1	FITTING BRASS TEE DBL 3/8 BARB
16	342435	3	FITTING 1/4MPTx3/8HB BRASS
17	450076	4	CRIMP CLAMP SS 185R
18	710961	4	SCR-SC 1/4-20 X .37
19	711206	1	BLT-HH 1/4-20 X .87 ST PL
20	711231	2	BLT-HH 5/16-18X1.25 ST PL
21	711242	8	BLT-HEX 3/8 -16X1.00 ZP
22	711246	6	BLT-HH 3/8-16 X .87 STL Z
23	711316	1	NUT-HEX 1/4-20 ST PL
24	711350	12	NUT NYLOC 10-32
25	711503	12	WSR, FLAT#10
26	711506	10	WSR-FLT .344 X .690 X .062 STL ZINC
27	711512	4	WSR-FLAT .75X1.37X.08
28	711515	6	WSR-FLAT .406 X .812 X .0625
29	711516	4	WSR- FLAT .31 X 1.25 X .05
30	711545	2	WSR-HELICAL 5/16
31	711546	14	WSR-HELICAL 3/8
32	711554	2	WSR-INTERNAL LOCK 1/4 ID
33	711575	2	WSR-FLT .31x.75x.06ST
34	712301	14	WSR-FLAT .87 X .38 X .06
35	712537	12	10-24 X .75 SS TRUSS HD SCR
36	744016-1	2	CAP .15 MICROFARAD 5/16R-1/4FORK
37	748003	1	MOTOR, 28" DUAL RIGHT ANGLE
38	748077	1	WIRE ASSY, BRUSH DECK DISK
39	828370	2	1/4 NPT SOCKET FEMALE END COUPLI
40	3312402	2	HUB-SCRUB BRUSH DRIVE

32" Disc Scrub Deck Assembly

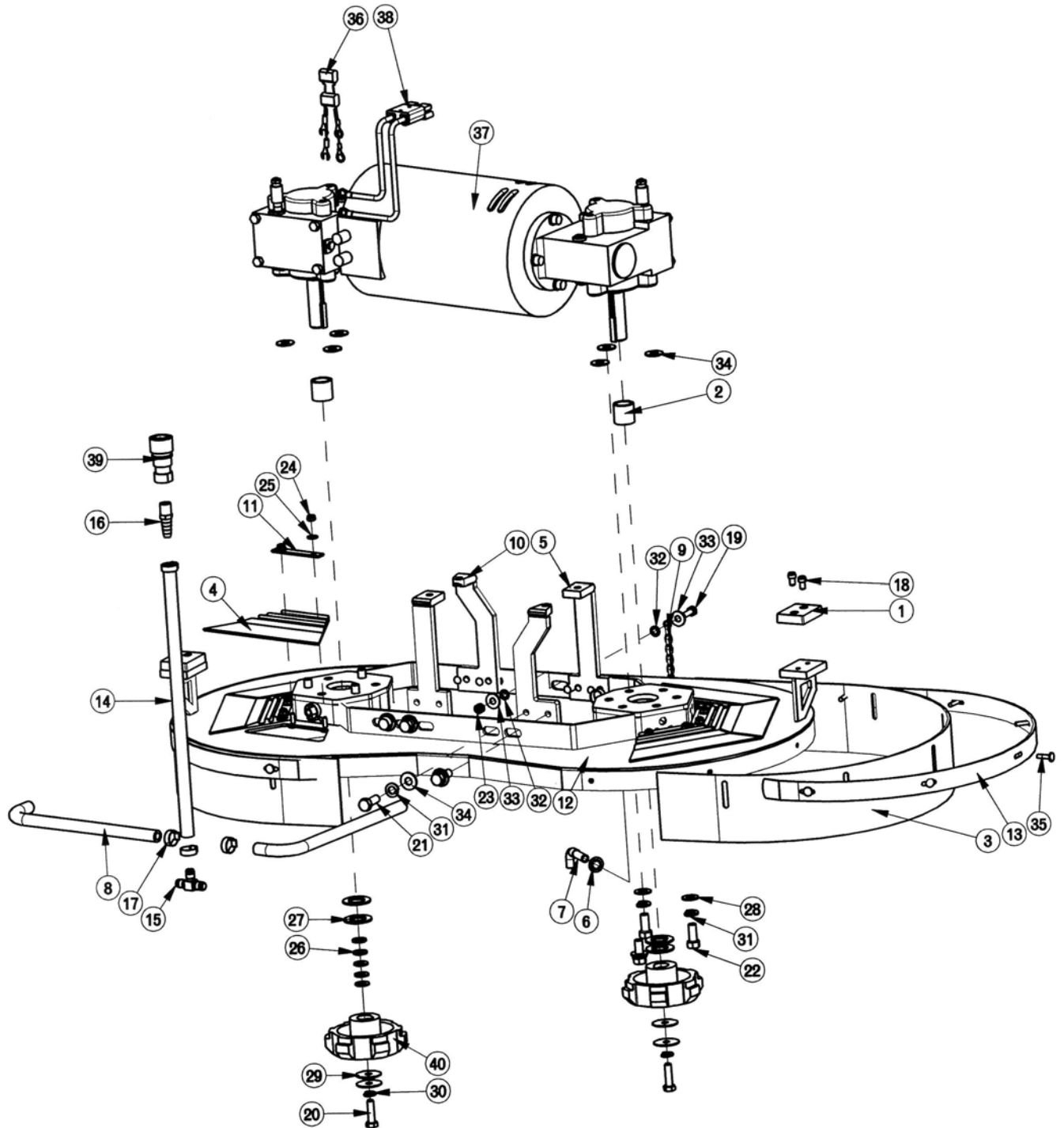

32" Disc Scrub Deck Assembly BOM

BILL OF MATERIAL - 281651			
ITEM	PART NO.	REQ'D	DESCRIPTION
1	281515	2	WEAR PLATE
2	281611	2	HUB-SCRUB SPACER TUBE
3	281613	2	SKIRT, 28" DISK
4	281614	6	FLAP, DISK
5	281616	2	DISK MTG BRKT WMT
6	281633	2	SPEED NUT - 3/8"
7	281634	2	DISK SOLUTION FEED ASSY
8	281642	2	SOL. FEED END HOSE
9	281644	1	DRAG CHAIN ASSY, DISK SCRUBDECK
10	281657	2	DISK MTG BRKT WMT
11	281660	6	STRAP, KEEPER
12	281662	1	DISK SCRUBDECK WMT, 32"
13	281665	2	STRAP, DISK
14	320253	1	HOSE, SOLUTION VALVE 14"
15	320266	1	FITTING BRASS TEE DBL 3/8 BARB
16	342435	1	FITTING 1/4MPTx3/8HB BRASS
17	450076	6	CRIMP CLAMP SS 185R
18	710961	4	SCR-SC 1/4-20 X .37
19	711206	1	BLT-HH 1/4-20 X .87 ST PL
20	711231	2	BLT-HH 5/16-18X1.25 ST PL
21	711242	8	BLT-HEX 3/8 -16X1.00 ZP
22	711246	6	BLT-HH 3/8-16 X .87 STL Z
23	711316	1	NUT-HEX 1/4-20 ST PL
24	711350	12	NUT NYLOC 10-32
25	711503	12	WSR, FLAT#10
26	711506	10	WSR-FLT .344 X .690 X .062 STL ZINC
27	711512	4	WSR-FLAT .75X1.37X.08
28	711515	6	WSR-FLAT .406 X .812 X .0625
29	711516	4	WSR- FLAT .31 X 1.25 X .05
30	711545	2	WSR-HELICAL 5/16
31	711546	14	WSR-HELICAL 3/8
32	711554	2	WSR-INTERNAL LOCK 1/4 ID
33	711575	2	WSR-FLT .31x.75x.06ST
34	712301	14	WSR-FLAT .87 X .38 X .06
35	712537	12	10-24 X .75 SS TRUSS HD SCR
36	744016-1	2	CAP .15 MICROFARAD 5/16R-1/4FORK
37	748033	1	MOTOR, 32" DUAL RIGHT ANGLE
38	748077	1	WIRE ASSY, BRUSH DECK DISK
39	828370	1	1/4 NPT SOCKET FEMALE END COUPLI
40	3312402	2	HUB-SCRUB BRUSH DRIVE

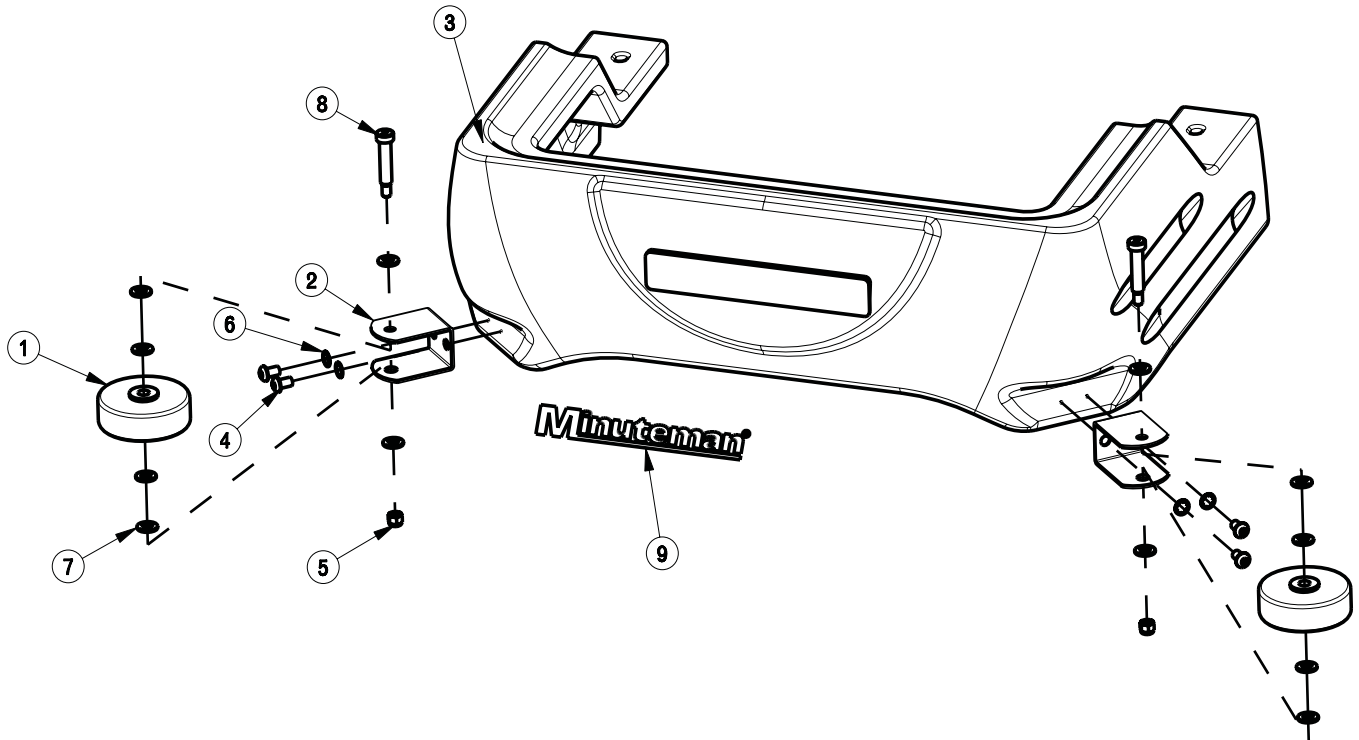

BILL OF MATERIAL - 320745			
ITEM	PART NO.	REQ'D	DESCRIPTION
1	320013	2	WHEEL, BUMPER 4"
2	320744	2	BRACKET, BUMPER WHEEL
3	320952	1	ES2832 BUMPER COVER, 28"
4	710985	4	SCR-SC 3/8-16 X .62 ST PL
5	711380	2	NUT-NYLOC 3/8-16 NUT
6	711555	4	WSR-INTERNAL LOCK 3/8
7	711592	12	WSR-FLAT .50 X .9 X .075 NYL
8	712120	2	BLT- SHLDR 1/2 X 2
9	715385	1	MINUTEMAN LOGO 1.4 X 9.6

Bumper Cover Assembly - 32"

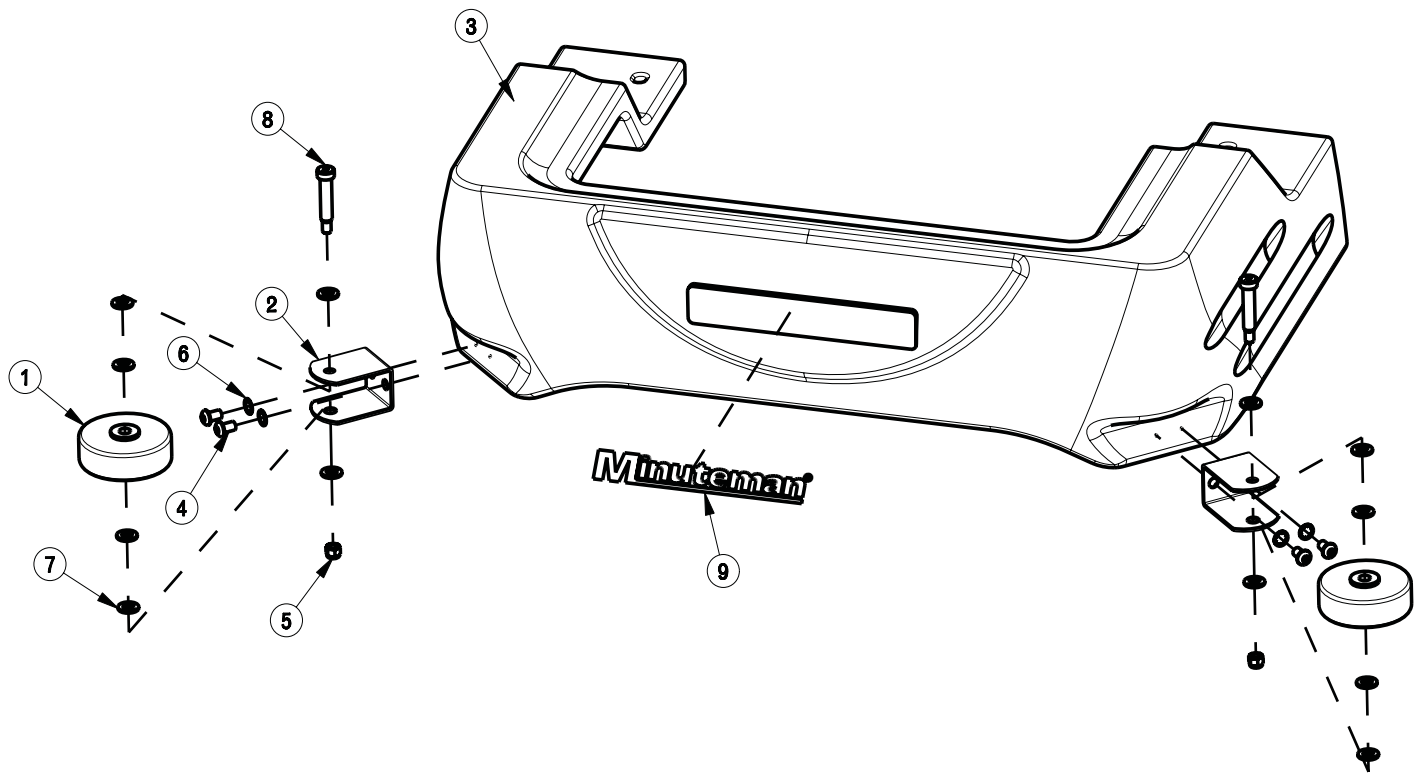

BILL OF MATERIAL - 320746			
ITEM	PART NO.	REQ'D	DESCRIPTION
1	320013	2	WHEEL, BUMPER 4"
2	320744	2	BRACKET, BUMPER WHEEL
3	320953	1	ES2832 BUMPER COVER, 32"
4	710985	4	SCR-SC 3/8-16 X .62 ST PL
5	711380	2	NUT-NYLOC 3/8-16 NUT
6	711555	4	WSR-INTERNAL LOCK 3/8
7	711592	12	WSR-FLAT .50 X .9 X .075 NYL
8	712120	2	BLT- SHLDR 1/2 X 2
9	715385	1	MINUTEMAN LOGO 1.4 X 9.6

Rear Squeegee Assembly

Used on standard ES2832 models

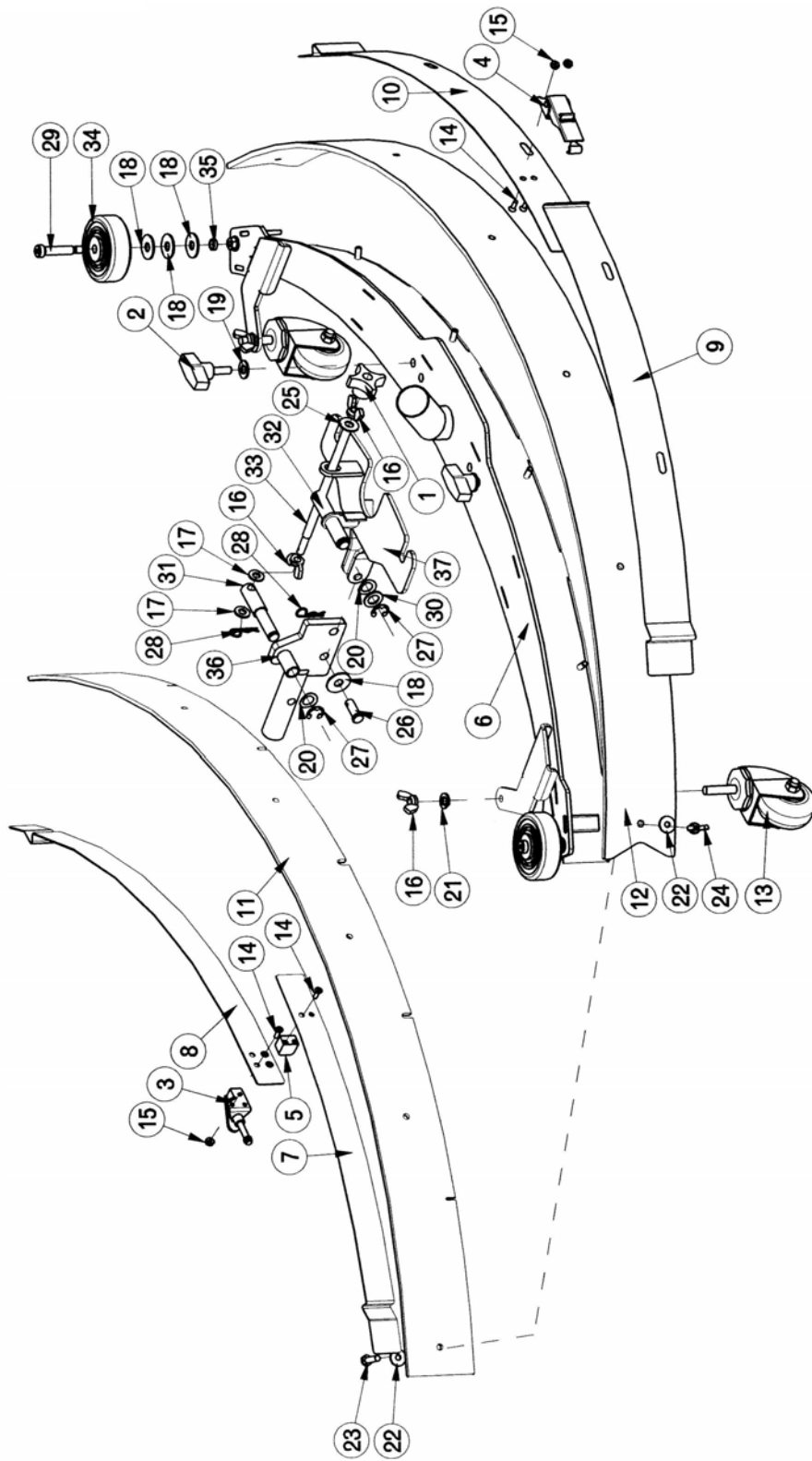

BILL OF MATERIAL - 320930-1 & 320940-1			
ITEM	PART NO.	REQ'D	DESCRIPTION
1	241057	1	KNOB, 3/8-16 X 1-3/4 FOUR PRONG.
2	241745	2	WING BOLT 3/8-16 X 1.00
3	281074	1	SQUEEGEE TOGGLE CLAMP, 2800
4	281075	1	SQUEEGEE LATCH, 2800
5	281740	1	STOP BAR
6	320931	1	NEW SQUEEGEE WMT ASSY, 320
7	320946	1	STRAP - FRONT STOP
8	320947	1	STRAP - FRONT CLAMP
9	320948	1	STRAP - REAR CATCH
10	320949	1	STRAP - REAR LATCH
11	320950	1	FRONT BLADE, SQUEEGEE GUM RUBBER, 32"
12	320951	1	REAR BLADE, SQUEEGEE GUM RUBBER, 32"
13	430325	2	CASTER WHEEL 3/8"-16 X 1.500
14	710530	7	SCR-MC FL HD 8-32 X .50 BRS
15	711026	5	NUT, HEX 8-32 NYLOC SS
16	711367	4	NUT- WING 3/8-16 ST PL
17	711506	2	WSR-FLT .344 X .690 X .062 STL ZINC
18	711507	8	WSR-FLAT .37 X 1.12 X .06
19	711515	2	WSR-FLAT .406 X .812 X .0625
20	711524	2	WSR-WAVE .52 X .87 X .01
21	711546	2	WSR-HELICAL 3/8
22	711550	4	WSR NYLON .25 ID X .75 OD
23	711560	2	SCREW-HH 1/4-20X1.00 NYLON
24	711563	2	NUT- WING 1/4-20 NYLON
25	711569	1	WSR-FLT .390 X .880 X .062 NYL
26	711668	1	CLEVIS PIN, 3/8X1 11-141
27	711713	2	RETAINING RING - "E" TYPE EXT .500
28	711808	2	COTTER PIN-HAIR #13
29	712091	2	SHOULDER BLT 3/8 X 1.50
30	712310	1	WSR- FLAT .52 X .87 X .06 PL
31	762004	1	PIN, ADJUSTING
32	762005	1	ADJUSTING PIN, THREADED
33	762006	1	THREADED ROD, 3/8-16 X 7.5" LG
34	808829	2	WHEEL, TRUCK
35	832015	2	SPACER .38 X .50 X .140
36	320154-1	1	SQUEEGEE MOUNT WELDT NEW
37	320941-1	1	SQUEEGEE MOUNT BRACKET WMT

SQUEEGEE ASSEMBLY COMPLETE

320297

Used on ES2832HD, ES2832DNA,
ES2832DNA-BJ models only

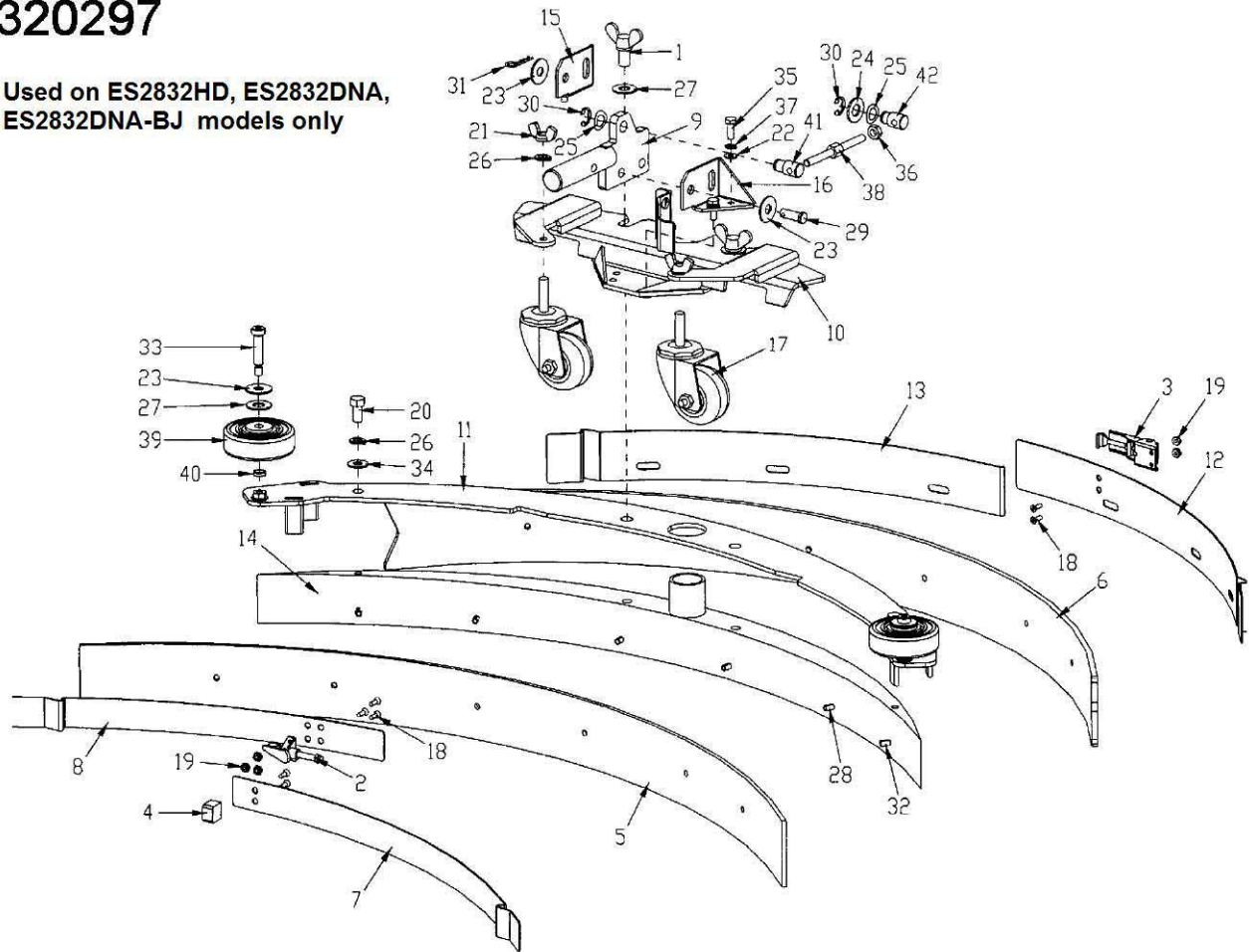

Parts List

ITEM	PART NO.	REQ'D	DESCRIPTION	ITEM	PART NO.	REQ'D	DESCRIPTION
1	220249	2	WING BOLT 1/2-13 X .75"	22	711504	4	WSR-FLAT 1/4 ID SS
2	281074	1	SQUEEGEE TOGGLE CLAMP, 2800	23	711507	4	WSR-FLAT .37 X 1.12 X .06
3	281075	1	SQUEEGEE LATCH, 2800	24	711509	1	WSR-FLAT 1/2 (.54X1.082X.087)
4	281740	1	STOP BAR	25	711524	2	WSR-WAVE .52 X .87 X .01
5	320014	1	SQUEEGEE FRONT BLADE 320	26	711546	4	WSR-HELICAL 3/8
6	320015	1	SQUEEGEE REAR BLADE 320	27	711592	4	WSR NYLON .5 X 1.06 X .06
7	320021	1	STRAP - FRONT STOP 320	28	711658	8	ROLL PIN 1/4"X1.00"
8	320022	1	STRAP-FRONT CLAMP 320	29	711668	1	CLEVIS PIN, 3/8X1 11-141
9	320154	1	SQUEEGEE MOUNT WELD'T NEW	30	711713	2	RETAINING RING - "E" TYPE EXT .500
10	320289	1	SQ. MTG BRKT WELDM'T	31	711808	1	COTTER PIN-HAIR #13
11	320293	1	TOP PLATE WELDMENT, 320	32	711904	2	ROLL PIN 1/4"X1.50"
12	320310	1	STRAP-REAR LATCH 320	33	712091	2	SHOULDER BLT 3/8 X 1.50
13	320313	1	STRAP-CATCH 320	34	712301	2	WSR-FLAT .87 X .38 X .06
14	320314	1	320 SQ CASTING MCHD, NEW	35	712562	4	BOLT-HH 1/4-20X3/4 SS
15	383424	1	MOUNTING BRACKET-RIGHT	36	712680	1	NUT-HEX 5/16-18 SS
16	383425	1	MOUNTING BRACKET-LEFT	37	712758	4	WSR-HELICAL 1/4 SS
17	430325	2	CASTER WHEEL 3/8"-16 X 1.500	38	750689	1	ADJUSTMENT STUD
18	710530	7	SCR-MC FL HD 8-32 X .50 BRS	39	808829	2	WHEEL,TRUCK
19	711026	5	NUT, HEX 8-32 NYLOC SS	40	832015	2	SPACER .38 X .50 X .140
20	711241	2	SCR-HEX 3/8 -16X .75" ZP	41	762022PLT	1	NUT, ADJUSTING (LH)
21	711367	2	NUT- WING 3/8-16 ST PL	42	762257PLT	1	NUT, ADJUSTING (RH)

Off Aisle Wand Assembly (Optional)

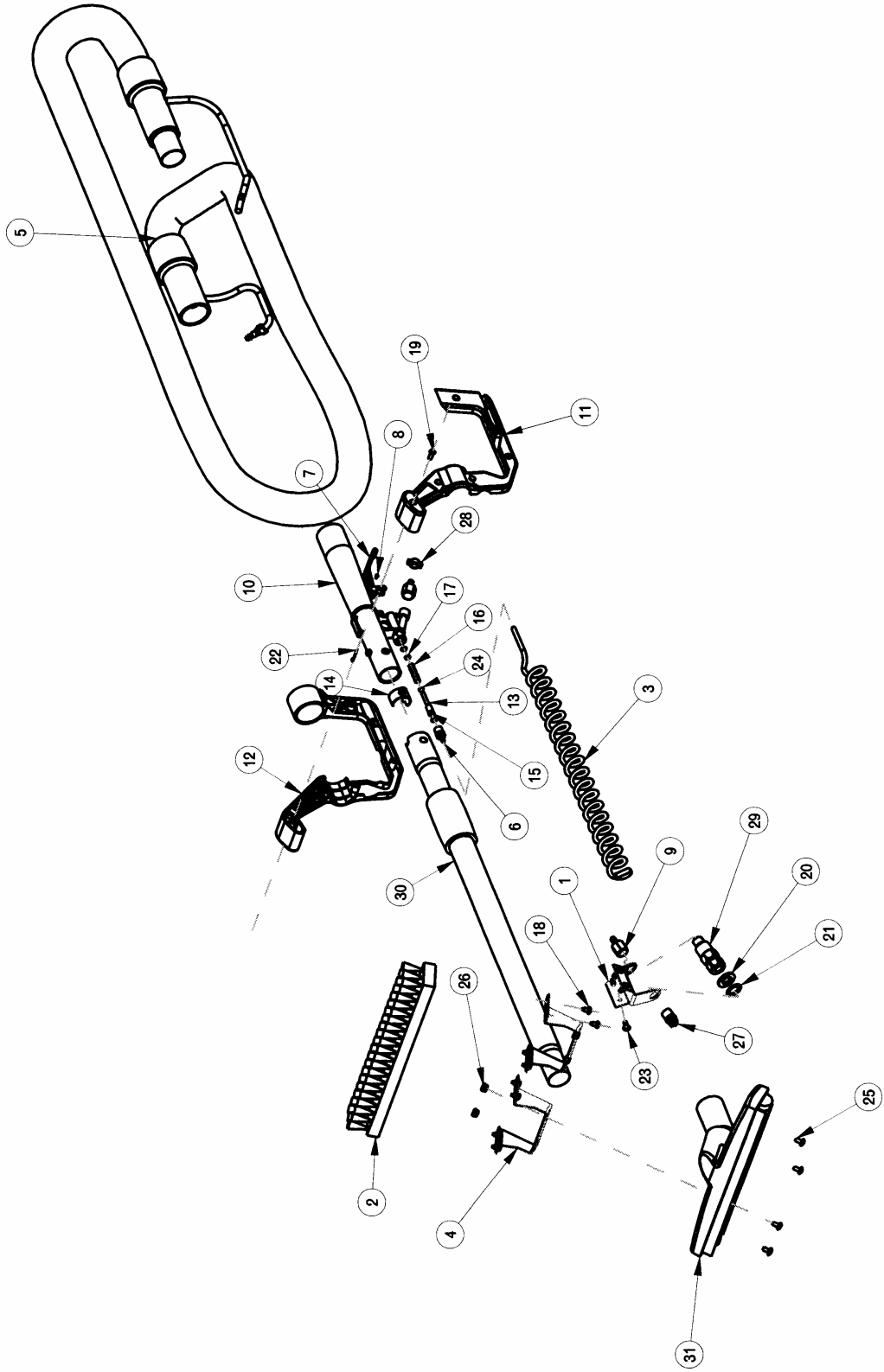

Off Aisle Wand Assembly BOM

BILL OF MATERIAL - 281071			
ITEM	PART NO.	REQ'D	DESCRIPTION
1	100004	1	SPRY JET BKT MC SCRB14GA
2	281044	1	BRUSH 12 X 1.75 X 1.12
3	281045	1	HOSE, SELF-RETRACTING SOLUTION
4	281049	2	BRUSH WAND BRACKET
5	281072	1	HOSE ASSEMBLY, SPRAY/VAC, 2800
6	350280	1	FITTING BRASS 1/8 MPT - 1/8 BARB
7	390053	1	TRIGGER SOL VALVE
8	390063	2	RD HD GRV STUD #2427
9	450218	2	FITTING, BRASS 1/4 FPT, 1/8 BARB
10	450256	1	PICKUP TUBE
11	450257	1	TRIGGER GUARD,LEFT
12	450258	1	TRIGGER GUARD,RIGHT
13	450261	1	VALVE STEM
14	450262	1	LOCKING BUTTON
15	450265	3	O-RING, BROWN
16	450267	1	SPRING SS LC-038D-13
17	450301	1	WASHER, NYLON
18	711116	8	SCR-ST-A 10 X .37 PL
19	711163	5	SCR-HI/LO #10-16 X 1/2
20	711579	1	WSR-FLAT .56 X 1.00 X .100
21	711594	1	WSR-FLAT .56 X .88 X .03
22	711803	1	COTTER PIN-HAIR
23	711903	4	RIVET-POP 3/16"
24	712323	1	WSR-FLT .195 X .281 X .03SS
25	712540	4	SCR-MC TR HD 10-24 X .37 SS
26	712638	4	NUT, HEX 10-24 SS NYLOC
27	829115	1	VEEJET 1/4"
28	830082	1	HOSE CLAMP 3/8
29	833384	1	VALVE-BALL TYPE CHECK, 1/4" AB
30	270162MCH	1	TELESCOPING WAND (MACHINED)
31	281048MCH	1	SQUEEGEE NOZZLE - 12" (MACHINED)

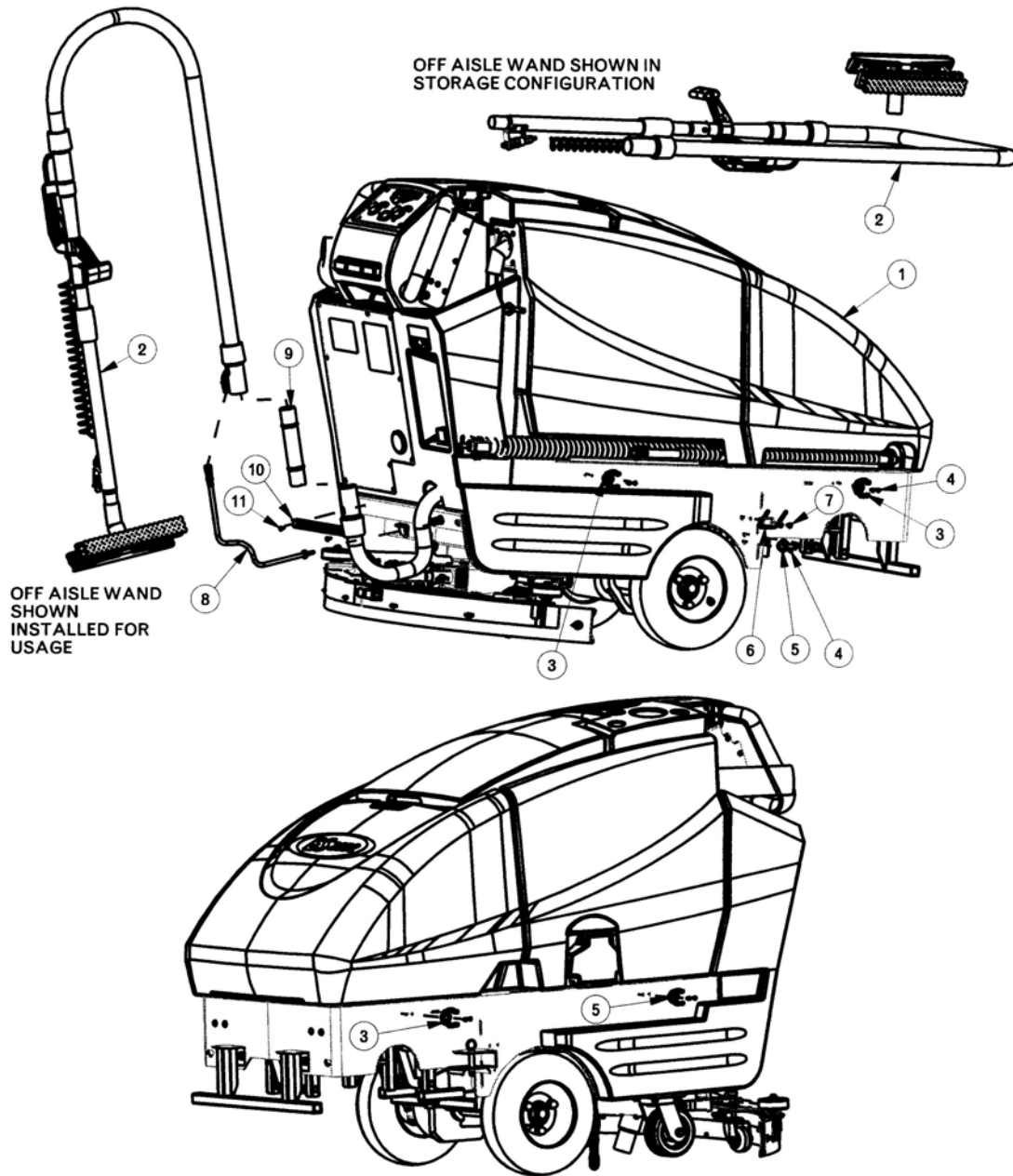

BILL OF MATERIAL OFF AISLE WAND KIT			
ITEM	PART NO.	REQ'D	DESCRIPTION
1	ES2832	1	MAIN ASSY
2	281071	1	OFF AISLE WAND ASSY, 2800
3	260579	3	TOOL CLIP, 1.5" HOSE
4	710528	10	SCR-MC 8-32 X .37 BRS
5	270161	2	TOOL CLIP
6	320899	1	HANGER HOOK WMT
7	712822	2	SCR-MC TR HD 10-24 X .5 SS
8	320999	1	ES2832 WAND ADAPTER ASSY
9	800020	1	1.5" HOSE PLUG CPLG
10	260149	1	U CHANNEL 12"
11	711124	2	SCR-ST 8-10 X .37 NI

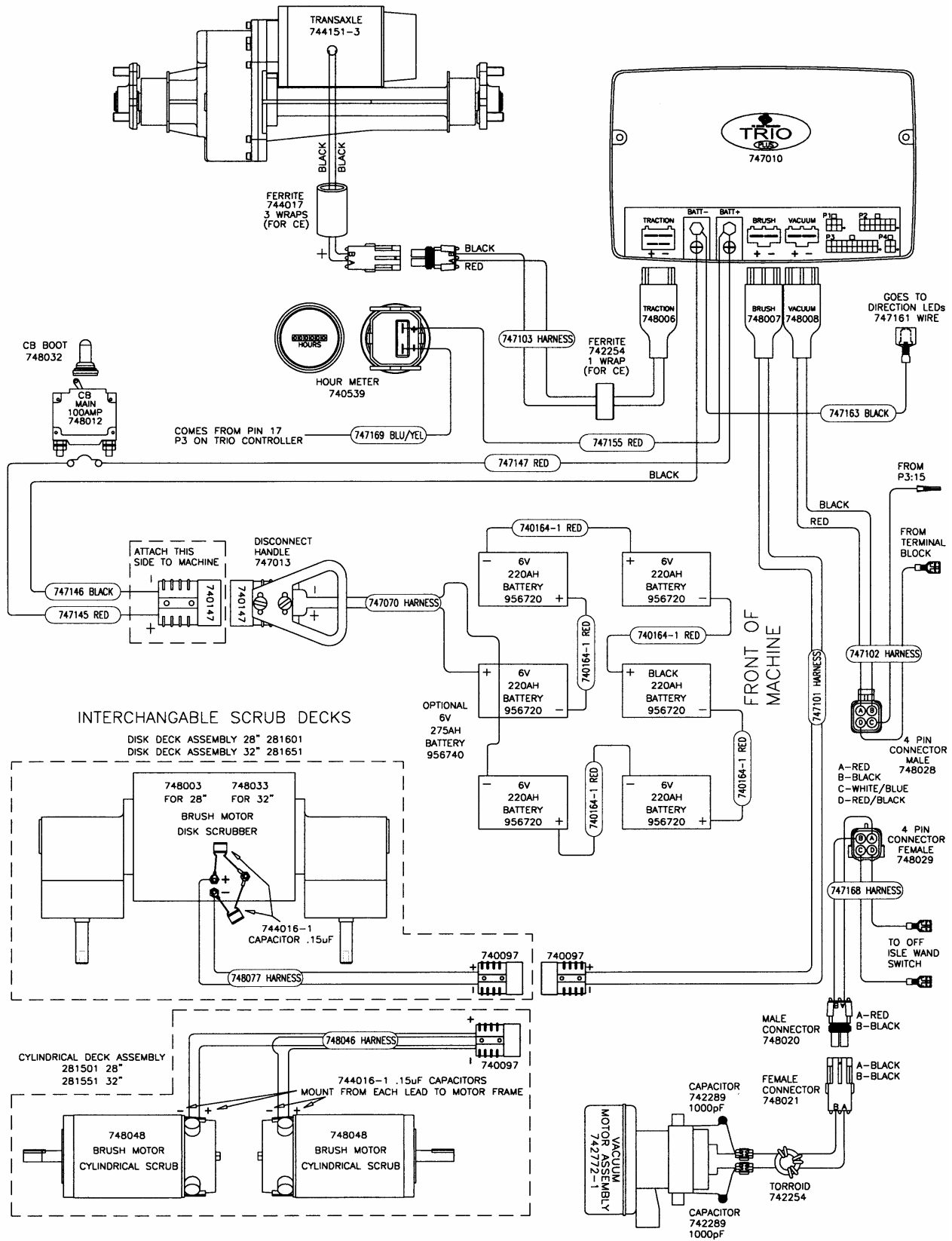

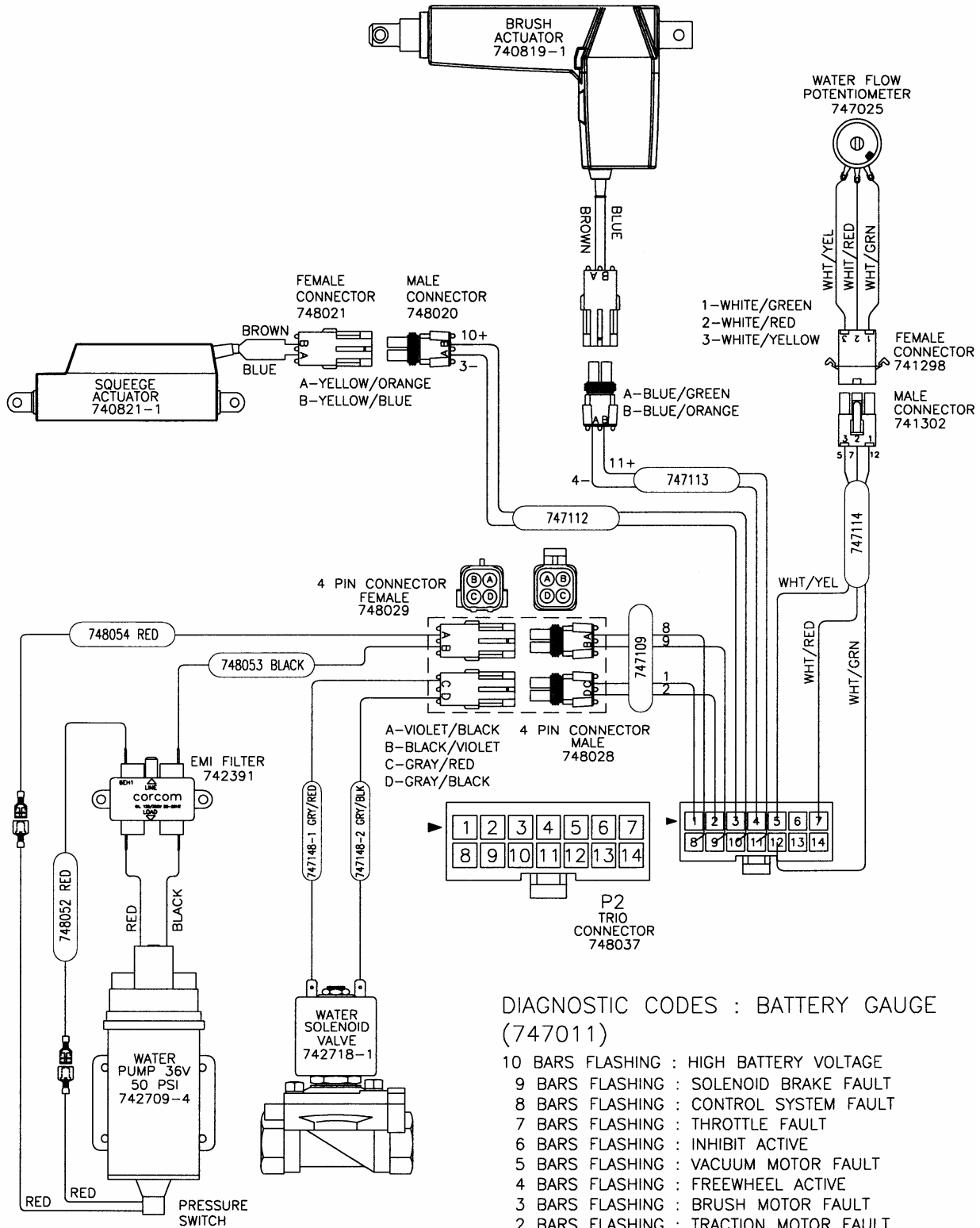

DIAGNOSTIC CODES : BATTERY GAUGE (747011)

- 10 BARS FLASHING : HIGH BATTERY VOLTAGE
- 9 BARS FLASHING : SOLENOID BRAKE FAULT
- 8 BARS FLASHING : CONTROL SYSTEM FAULT
- 7 BARS FLASHING : THROTTLE FAULT
- 6 BARS FLASHING : INHIBIT ACTIVE
- 5 BARS FLASHING : VACUUM MOTOR FAULT
- 4 BARS FLASHING : FREEWHEEL ACTIVE
- 3 BARS FLASHING : BRUSH MOTOR FAULT
- 2 BARS FLASHING : TRACTION MOTOR FAULT
- 1 BAR FLASHING : LOW BATTERY VOLTAGE
- 10 BARS RIPPLING UP AND DOWN: THROTTLE IS DISPLACED ON START UP

Grounding

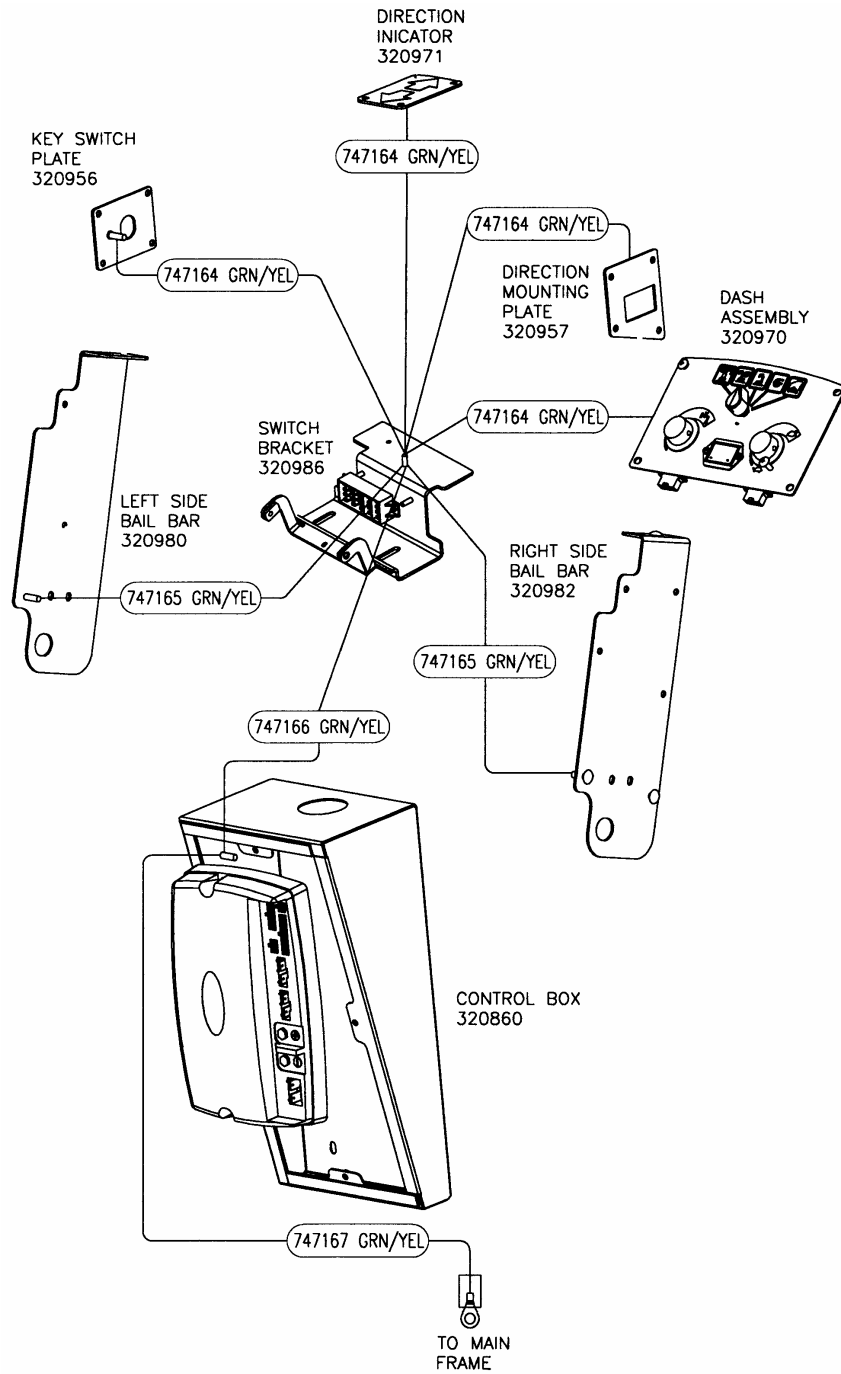

P2: TRIO CONNECTOR

PIN #	COLOR	FUNCTION
1	GRAY/RED	WATER SOLENOID VALVE
2	GRAY/BLACK	WATER SOLENOID VALVE
3	YELLOW/ORANGE	SQUEEGE ACTUATOR
4	BLUE/GREEN	BRUSH ACTUATOR
5	WHITE/YELLOW	WATER FLOW POTENTIOMETER (SLOW)
6	-	-
7	WHITE/RED	WATER FLOW POTENTIOMETER (WIPER)
8	VIOLET/BLACK	WATER PUMP
9	BLACK/VIOLET	WATER PUMP
10	YELLOW/BLUE	SQUEEGE ACTUATOR
11	BLUE/ORANGE	BRUSH ACTUATOR
12	WHITE/GREEN	WATER FLOW POTENTIOMETER (FAST)
13	-	-
14	-	-

P3: TRIO CONNECTOR

PIN #	COLOR	FUNCTION
1	YELLOW/RED	5 MODE SWITCH: LIGHT SCRUB
2	YELLOW/BLACK	5 MODE SWITCH: HEAVY SCRUB
3	YELLOW	5 MODE SWITCH: TRANSPORT
4	WHITE ORANGE	BELLY BAR SWITCH
5	BLUE/WHITE	DECK RAISE/LOWER SWITCH
6	RED/YELLOW	BATTERY GAUGE SIGNAL
7	-	-
8	RED/WHITE	ON/OFF REF (B+)
9	BLACK/ORANGE	SPEED POTENTIOMETER (SLOW)
10	BLACK/PINK	SPEED POTENTIOMETER/TRACTION SWITCH
11	YELLOW/WHITE	5 MODE SWITCH: VACUUM ONLY
12	YELLOW/GRAY	5 MODE SWITCH: DOUBLE SCRUB
13	YELLOW/VIOLET	REVERSE SWITCH
14	-	-
15	WHITE/BLUE	OFF ISLE WAND
16	RED/BLACK	HIGH SWITCH REF 5VDC
17	BLUE/YELLOW	HOUR METER
18	RED/VIOLET	ON/OFF INPUT-KEY SWITCH
19	BLACK/RED	LOW SWITCH REF 0VDC
20	BLACK/WHITE	SPEED POTENTIOMETER (FAST)

C4: KEY SWITCH

PIN #	HARNES COLOR	FUNCTION
1	RED/WHITE	POSITIVE TO LEDS
2	RED/VIOLET	SIGNAL-TRIO KSI P3:18
3	RED/WHITE	+V FROM TRIO P3:8
4	EMPTY	-

BATTERY GAUGE

PIN #	HARNES COLOR	FUNCTION
1	RED	SWITCHED 36VDC:P3-18
2	YELLOW	SIGNAL: P3-6
3	BLACK	SIGNAL REF 0V
4	WHITE	ESD DISCHARGE

C6: MODE SELECTOR SWITCH

SWT #	PIN #	COLOR	FUNCTION
1	1	YELLOW/BLACK	HEAVY SCRUB
2	2	YELLOW/RED	LIGHT SCRUB
3	3	YELLOW/GRAY	DOUBLE SCRUB
4	4	YELLOW/WHITE	VACUUM ONLY
5	5	YELLOW	TRANSPORT
C	6	RED/BLACK	SWITCH REF 5V

Minuteman International Made Simple Commercial Limited Warranty

Minuteman International, Inc. warrants to the original purchaser/user that the product is free from defects in workmanship and materials under normal use. Minuteman will, at its option, repair or replace without charge, parts that fail under normal use and service when operated and maintained in accordance with the applicable operation and instruction manuals. All warranty claims must be submitted through and approved by factory authorized repair stations.

This warranty does not apply to normal wear, or to items whose life is dependent on their use and care, such as belts, cords, switches, hoses, rubber parts, electrical motor components or adjustments. Parts not manufactured by Minuteman are covered by and subject to the warranties and/or guarantees of their manufacturers. Please contact Minuteman for procedures in warranty claims against these manufacturers.

Special warning to purchaser -- Use of replacement filters and/or prefilters not manufactured by Minuteman or its designated licensees, will void all warranties expressed or implied. A potential health hazard exists without original equipment replacement.

All warranted items become the sole property of Minuteman or its original manufacturer, whichever the case may be.

Minuteman disclaims any implied warranty, including the warranty of merchantability and the warranty of fitness for a particular purpose. Minuteman assumes no responsibility for any special, incidental or consequential damages.

This limited warranty is applicable only in the U.S.A. and Canada, and is extended only to the original user/purchaser of this product. Customers outside the U.S.A. and Canada should contact their local distributor for export warranty policies. Minuteman is not responsible for costs or repairs performed by persons other than those specifically authorized by Minuteman. This warranty does not apply to damage from transportation, alterations by unauthorized persons, misuse or abuse of the equipment, use of non-compatible chemicals, or damage to property, or loss of income due to malfunctions of the product.

If a difficulty develops with this machine, you should contact the dealer from whom it was purchased.

This warranty gives you specific legal rights, and you may have other rights which vary from state to state. Some states do not allow the exclusion or limitation of special, incidental or consequential damages, or limitations on how long an implied warranty lasts, so the above exclusions and limitations may not apply to you.

Cord Electric Group..... Three years parts, two years labor, ninety days travel (Not to exceed two hours)
Exceptions..... Port-A-Scrub, one year parts, six months labor
MPV 13, one year parts
MPV 14 and 18, two years parts, one year labor
RapidAir blower, one year parts, one year labor
Explosion-Proof Vacuum, one year parts, one year labor
Pneumatic Vacuums, three years parts, one year labor
EX 12 and EX12H, one year parts, one year labor

Battery Operated Group..... Three years parts, two years labor, ninety days travel
(Not to exceed two hours)
Exceptions..... Sweepers, one year parts, one year labor, ninety days travel
(Not to exceed two hours)

Internal Combustion Group....One year parts, one year labor, ninety day travel
(Not to exceed two hours)

Replacement Parts.....Ninety days

Batteries.....0-3 months replacement, 4-12 months pro-rate

Polypropylene Plastic Tanks...Ten years, no additional labor