



## Electronic Service Manuals

This electronic document is provided as a service to our customers. We do not create the contents of the information contained in this document. Should you have detailed questions pertaining to the information contained in this document, you may contact Michco, or the manufacturer which provided the original information in this electronic deliverable. Michco's only part in this electronic deliverable was the electronic assembly process. By providing this manual on line we are not guaranteeing parts availability.

You may contact Michco through the following methods:

Phone (517) 484-9312 or (800) 331-3339

2011 N. High St. -- Lansing, Michigan -- 48906

Fax: (517) 484-9836

Email: [CustServe@Michco.com](mailto:CustServe@Michco.com)

Web site: [www.Michco.Com](http://www.Michco.Com)

Parts Web site: [www.FloorMachineParts.Com](http://www.FloorMachineParts.Com)

Order Parts on Line at:

**[www.FloorMachineParts.Com](http://www.FloorMachineParts.Com)**

Directly to Parts & Service:

By Email: **[Shop@Michco.com](mailto:Shop@Michco.com)**

By Fax: (517) 702-2041

By Voice: Use numbers above.

**Serving the Cleaning Industry Since 1922**

Notice: All copyrighted material remains property of original owners, all trademarks are property of respective owners. Manuals are subject to Manufacturer's reproduction limitations. Originals or reproductions were provided by manufacturers through a request. We make no warranty as to the correctness of information provided in this document and you assume all risk. By placing these manuals on line we are not declaring our corporation to be an manufacturer authorized dealer or provider, please check our web site for authorized manufacturers we represent.



## Parts Manual

E20 Floor Scrubber

Traction Drive Cylindrical

# Technical Specifications

Model **E20 Traction Drive Cylindrical**

Model No. E20C / E20CQP / E20CQPG  
E20CCE / E20CQPCE / E20CQPGCE

	<b>E20</b>
Current (Max)	40 amps
Battery Capacity (Lead Acid)	140Ah @20 hr
Battery Capacity (Gel)	95Ah @20 hr
Sound Level	69 dBA
Cleaning path width	20 in (51 cm)
Squeegee width	34 in (86 cm)
Productivity (Traction Drive)	27,280 ft <sup>2</sup> /hr ( 2,534 m <sup>2</sup> )
Working speed (Traction Drive)	3.1 mph (5 km per hr)
Rated voltage	24 volts
Vacuum flow	65 cfm (110 m <sup>3</sup> /hr)
Vacuum waterlift	45 inches ( 112mbar)
Vacuum power	.60 HP (450 W)
Brush type	Cylindrical
Brush motor(s) power	3/4 HP (560W)
Number of brushes	2
Brush RPM	600 RPM
Solution capacity	12 Gal (45 liters)
Recovery capacity	13 Gal (49 liters)
Working Grade	2%
Weight with batteries	370 lbs (168 kg)
Weight without batteries	235 lbs (107 kg)
Dimensions (LxWxH)	44.5 x 24.0 x 38.0 (113.0 x 61.0 x 96.5 cm)
Drive Motor Power	1/5 HP (150W)

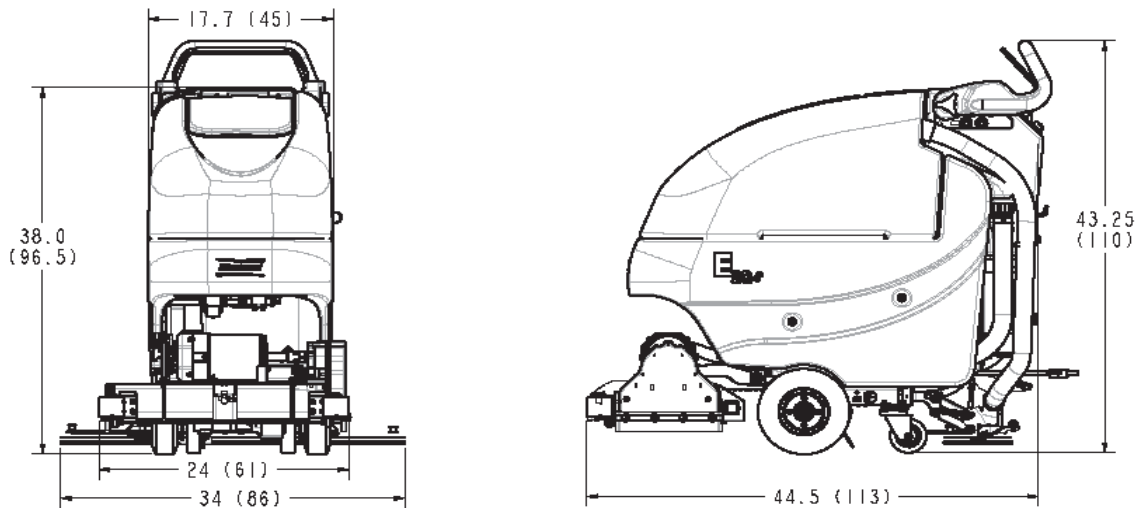

### For Safety When Servicing or Maintaining Machine

- Stop on level surface.
- Disconnect the power to the machine by pulling the red Battery Connector located under the recovery tank near the batteries.
- Avoid moving parts. Do not wear loose jackets, shirts, or sleeves when working on machine.
- Avoid contact with battery acid. Battery acid can cause burns. When working on or around batteries, wear protective clothing and safety glasses. Remove metal jewelry. Do not lay tools or metal objects on top of batteries.
- Do not clean machine with a pressure washer.
- Authorized personnel must perform repairs and maintenance. Use Minuteman supplied replacement parts.

## Table of Contents

Main Assembly .....	1
Main Assembly BOM .....	2
Traction Drive Base Assembly .....	3
Traction Drive Base Assembly BOM .....	4
E20 Base Assembly .....	5
Chassis Assembly .....	6
Chassis Assembly BOM .....	7
Solution Tank Assembly .....	8
Recovery Tank Assembly .....	9
Recovery Tank Assembly BOM .....	10
Handle Assembly .....	11
Pump Assembly .....	12
Solution Valve Assembly .....	12
Battery Tray Assembly .....	13
Electrical Box Assembly .....	14
Electrical Box Assembly BOM .....	15
Electrical Box Cover Assembly .....	16
Vac Motor Assembly .....	17
20" Cyl. Deck Assembly .....	18
Cylindrical Scrubdeck .....	19
Cylindrical Scrubdeck BOM .....	20
Cylindrical Scrubdeck SubAssy I - Idler Support .....	21
Cylindrical Scrubdeck SubAssy II - Gear Support .....	22
E20 Rear Squeegee Assembly .....	23
E20 Tension Band Sub-Assembly .....	24
Squeegee Mechanism Assembly .....	25
Wiring Diagrams .....	26
WARRANTY .....	30

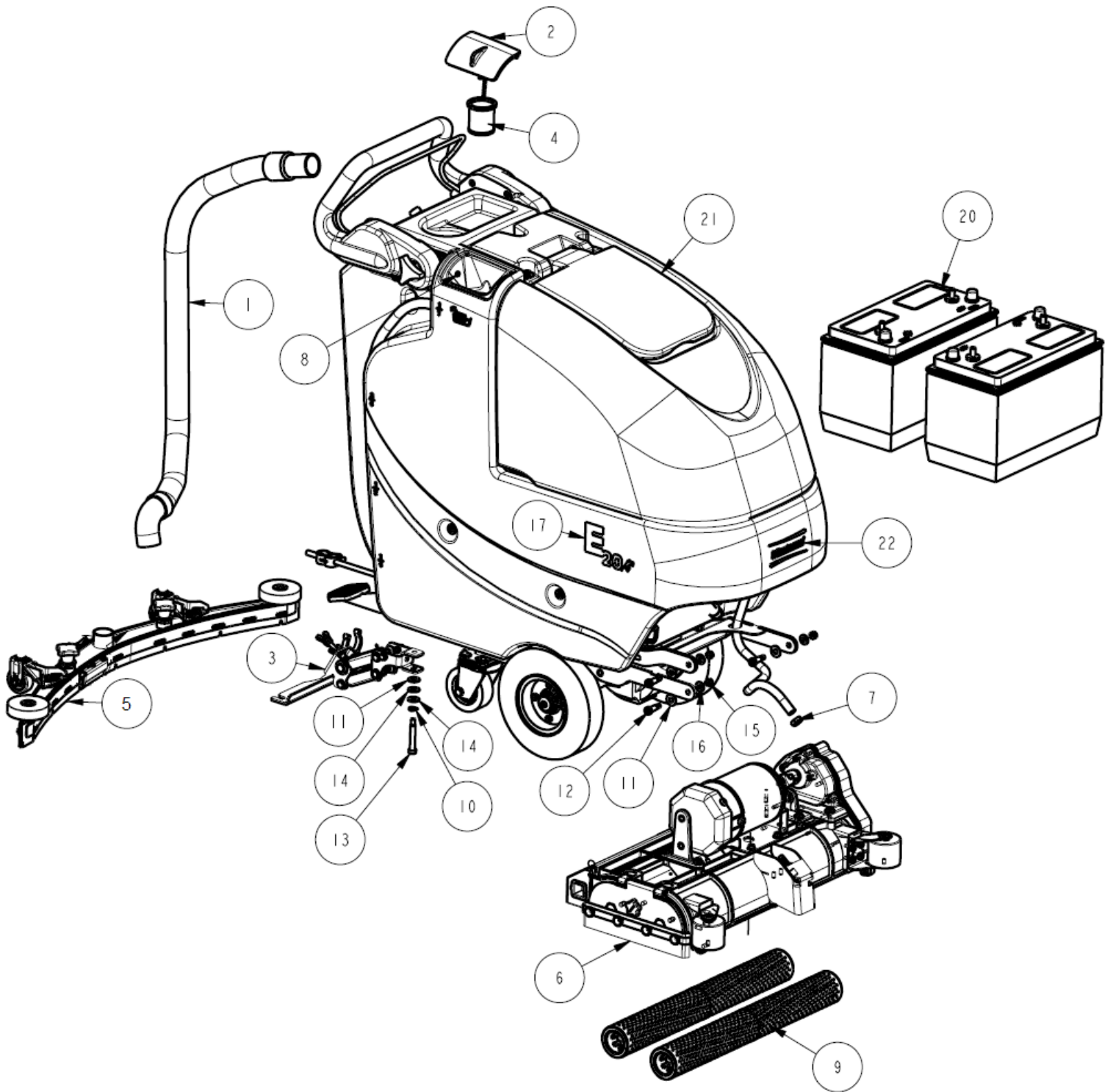

BILL OF MATERIAL - E20CQP			
ITEM	PART NO.	REQ'D	DESCRIPTION
1	172010	1	HOSE, CLEAR VAC W/ 45 CUFF
2	172018	1	SOLUTION TANK LID ASSY
3	172150	1	SQUEEGEE LIFT MECH ASSY
4	172159	1	FILTER, FILL PORT, ES1720
5	172534	1	SQUEEGEE, 34" (860)
6	172325	1	E20 CYL DECK ASSY
7	450076	1	CLAMP-CRIMP 185R SS
8	711118	1	SCR-ST-A 10 X .75 SS
9	172320-2	1	20" CYLINDRICAL POLY BRUSH
10	711523	1	WSR-WAVE .37X .68 X .08
11	711569	4	WSR-FLT .390 X .880 X .062 NYL
12	712081	3	SHOULDER BLT 5/16-18 X 3/8 X .75
13	712143	1	BLT-SHLD 3/8 X 2.0, 5/16-18
14	712301	2	WSR-FLAT .37 X .87 X .06
15	712683	3	NUT, HEX 5/16-18 NYLOC SS
16	712772	3	WSR-FLAT .344 x .75 x .06 SS
17	715920	2	DECAL, E20
18	740164-1	1	JUMPER CABLE ASSY, RED 4G 12"
19	747649	1	CABLE ASSY, BATTERY E17
20	956140	2	BATTERY, 12V 140AH
21	REF ONLY	1	CYL BASE ASSY-120V CHARGER
22	715914W	1	DECAL, MINUTEMAN W/SWOOSHES, WHITE
23	172008	1	SOLUTION TANK LID
24	172123	1	CHAIN, BEADEDSS W / EYELETS
25	712145	1	SCR-PAN HD HI/LO 6-19 X .37 SS
26	828062	1	CABLE TIE LARGE

OPTIONAL BRUSHES		
ITEM	PART NO.	DESCRIPTION
9.1	172320-1	BRUSH, 20" NYLON
9.2	172320-2	BRUSH, 20" POLY
9.3	172320-3	BRUSH, 20" GRIT

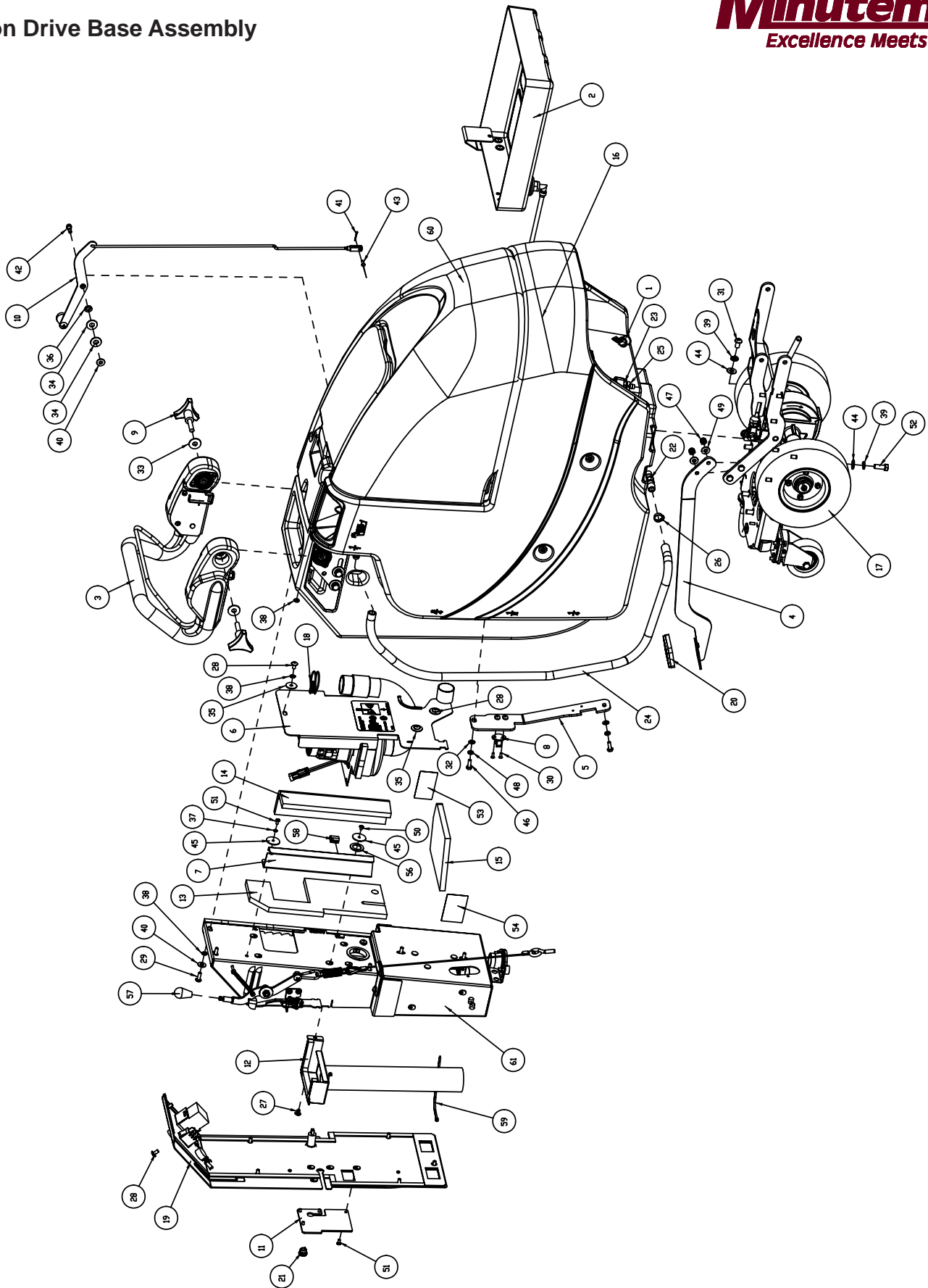

# Traction Drive Base Assembly BOM



BILL OF MATERIAL				BILL OF MATERIAL CONT'D			
ITEM	PART NO.	REQ'D	DESCRIPTION	ITEM	PART NO.	REQ'D	DESCRIPTION
1	82-54-A	1	CLAMP, MS21333-114	32	711504	2	WSR-FLAT 1/4 ID SS
2	172012	1	BATTERY TRAY ASSY	33	711507	2	WSR-FLAT .37 X 1.12 X .06
3	REF ONLY	1	E1720 TD HANDLE ASSY	34	711508	2	WSR-FLAT .44X 1.0X.08
4	172032	1	LIFT PEDAL WMT	35	711519	3	WSR- FLAT .25 X 1.01 X .06
5	172036	1	BKT, PEDAL STOP	36	711523	1	WSR-WAVE .37X .68 X .08
6	172050	1	VAC MOTOR ASSY	37	711543	1	WSR-HELICAL #10
7	172055	1	BKT, VAC AREA INSIDE COVER	38	711544	9	WSR-HELICAL 1/4
8	172065	1	CLIP, FOR 1/2" ID HOSE	39	711546	6	WSR-HELICAL 3/8
9	172085	2	KNOB, 3/8-16 STUD, 3 LOBE	40	711575	6	WSR-FLT .31x.75x..06ST
10	172112	1	SOL CONTROL ASSY	41	711803	1	COTTER PIN
11	172129	1	BKT, PWR CORD MOUNT	42	712041	1	BLT- SHLDR .31 X .375 X 1/4-20
12	172179	1	CHARGER INLET ASSEMBLY	43	712117	1	CLEVIS PIN 3/16
13	172184	1	FOAM COVER, REAR 1	44	712301	6	WSR-FLAT .37 X .87 X .06
14	172185	1	FOAM COVER, REAR 2	45	712312	2	WSR-FLAT .187 X 1.25
15	172187	1	FOAM COVER, FRONT 2	46	712562	2	BOLT-HH 1/4-20X3/4 SS
16	172305	1	PUMP ASM, E20 CYL	47	712683	2	NUT, HEX 5/16-18 NYLOC SS
17	REF ONLY	1	CHASSIS ASM, E20 CYL	48	712758	2	WSR-HELICAL 1/4 SS
18	172329	1	CLAMP-HOSE 1.56" 102122 MURRAY	49	712772	2	WSR-FLAT .344 x .75 x .06 SS
19	172330	1	CYL ELEC BOX COVER ASSY	50	712800	1	SCR-MC 10-24 X .25 ST PL
20	210142	1	PEDAL PAD	51	712810	5	SCR-MC 10-24 X .37 ST PL
21	293080	1	STRAIN RELIEF-HEYCO 1207	52	713042	4	BLT-HH 3/8-16 X 1 #5
22	342440	1	FITTING, TEE 3/4MPT 1/2BARB	53	715029	1	DECAL-NAME PLATE SERIAL
23	342441	1	FITTING, MGHT X 3/8HB PP	54	715047	1	DECAL-CLEAR LAMINATE 2X3
24	430156	1	HOSE, 1/2 X 42 CLEAR	55	715950	1	LABEL, PATENT NUMBERS
25	450076	1	CLAMP-CRIMP 185R SS	56	717025	1	WSR-FLAT 13/16ID X 1.25 X .08
26	450093	1	CRIMP CLAMP 3/4" STEPLESS	57	760592	1	KNOB, OVAL TAPERED
27	710177	1	SCR-MC 1/4-20 X .37 ST PL	58	809443	1	CLIP-WIRE & CORD
28	710178	10	SCR-MC 1/4-20 X .50 TRUSS STPL	59	828062	1	CABLE TIE LARGE
29	710380	5	SCR-MC RD HD 1/4-20 X .75 STL PL	60	REF ONLY	1	E1720 BASE ASSY
30	710530	2	SCR-MC FL HD 8-32 X .50 BRS	61	172075C-120	1	CYL ELEC BOX ASSY-120V
31	710985	2	SCR-SC 3/8-16 X .62 ST PL				

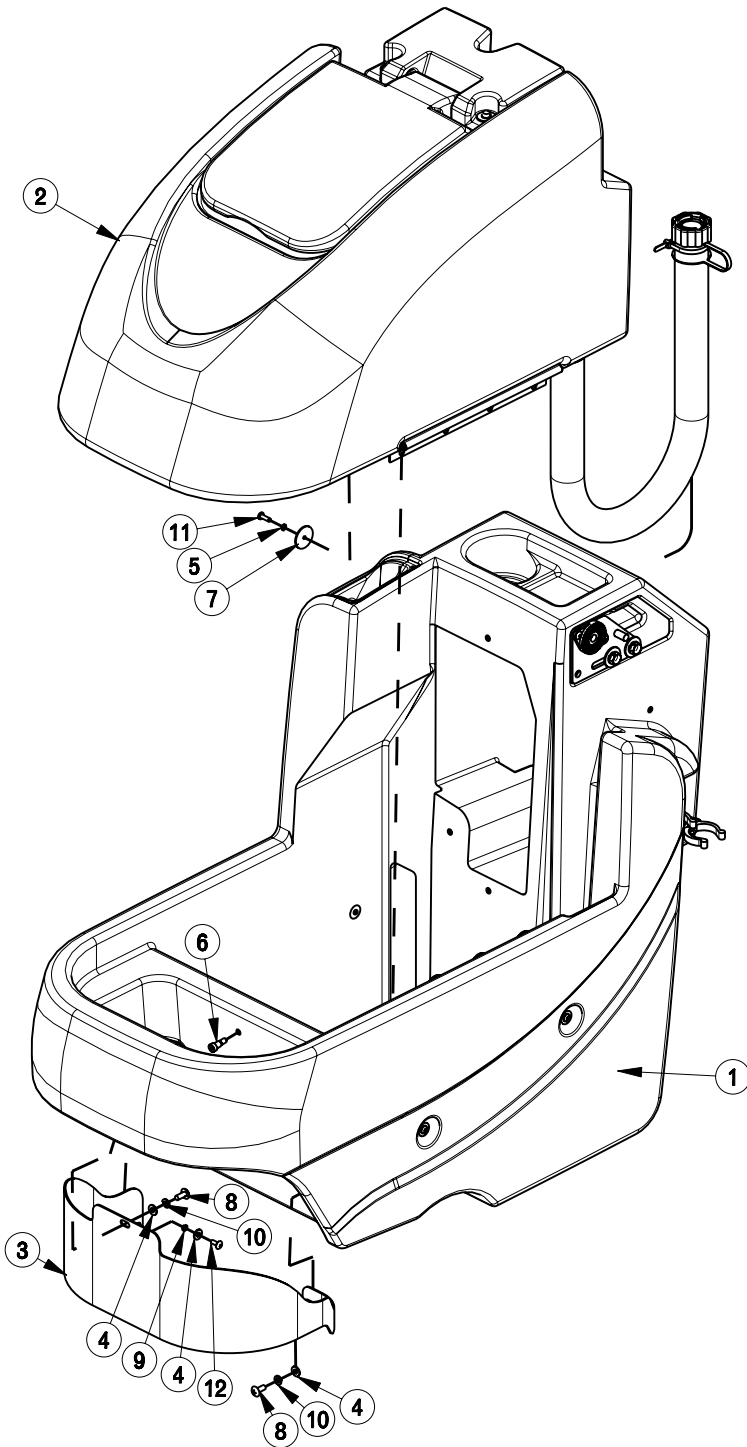

BILL OF MATERIAL - 172001BASE			
ITEM	PART NO.	REQ'D	DESCRIPTION
1	172013	1	SOL TANK ASSY, E1720
2	172014	1	REC TANK ASSY
3	172144	1	PANEL, FRONT 1720
4	711504	3	WSR-FLAT 1/4 ID SS
5	711543	4	WSR-HELICAL #10
6	712041	1	BLT - SHLDR 1/4-20 X .44 X .37
7	712312	4	WSR-FLAT .187 X 1.25
8	712565	2	SCR-MC 1/4-20X.63 SS TR HD
9	712757	1	WSR - HELICAL #10 SS
10	712758	2	WSR-HELICAL 1/4 SS
11	712812	4	SCR-MC 10-24 X .62 PPH ST PL
12	712822	1	SCR-MC TR HD 10-24 X .50 SS

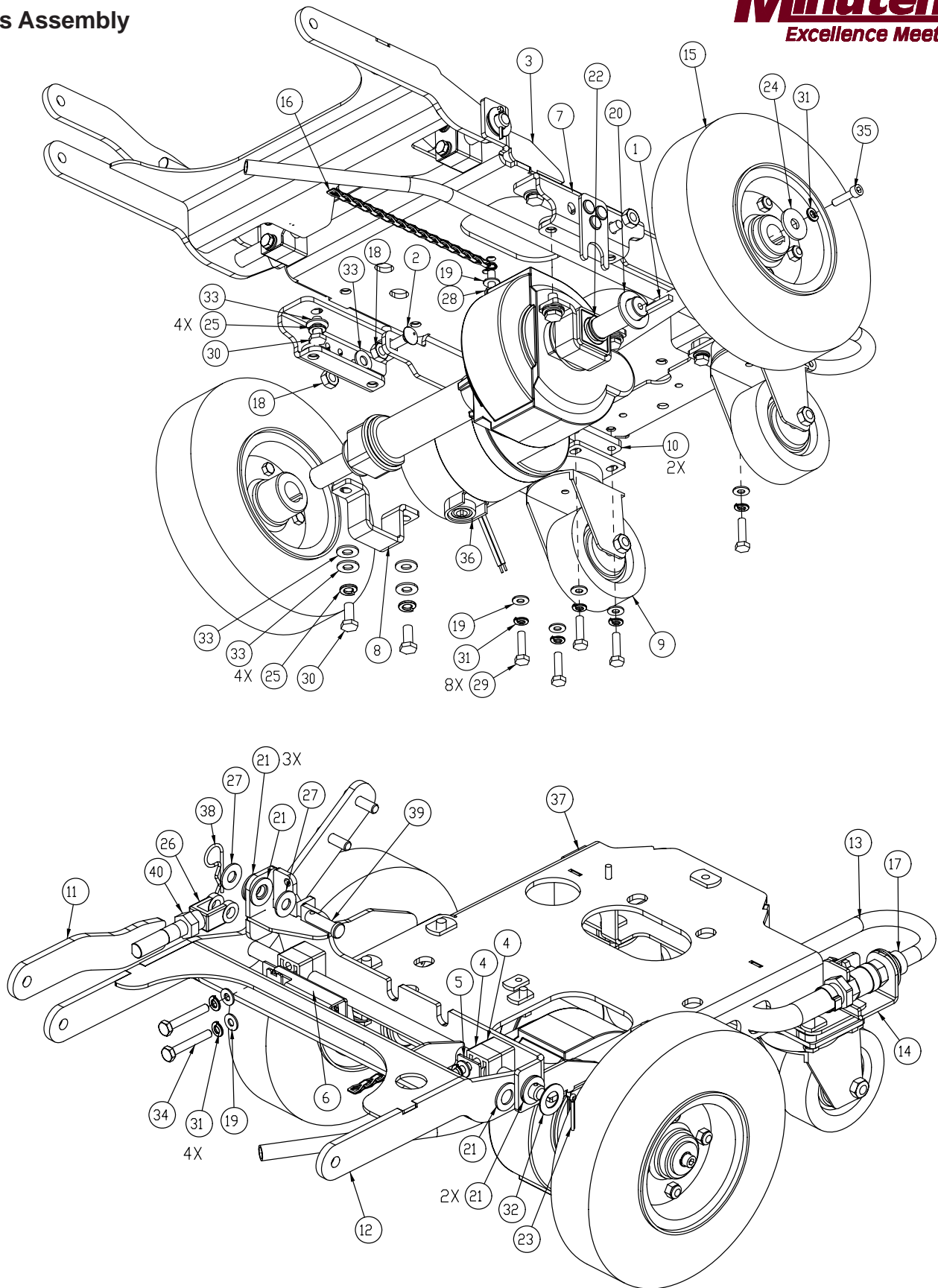

BILL OF MATERIAL - 172315			
ITEM	PART NO.	REQ'D	DESCRIPTION
1	61-65-A	2	KEY, 3/16 X 1-3/4"
2	70-516-16	2	BLT-CAR 5/16-18 X 1.00 ZP
3	172020	1	MAIN FRAME WMT, E1720
4	172038	4	BEARING BLOCK
5	172039	1	BEARING BLOCK PLATE
6	172110	1	DECK SWITCH ASSY
7	172113	2	BKT, TRANSAXLE MOUNT BASE
8	172114	2	BKT, TRANSAXLE MOUNT
9	172167	2	CASTER, 3-1/2 POLYURETHANE
10	172192	2	PLATE, 1/4" SPACER
11	172204	1	UPPER LIFT ARM WMT
12	172205	1	DECK LIFT WMT
13	241097	1	HOSE-WIRE REINF 3/8 X 31"
14	172264	1	SOLUTION VALVE ASSY
15	200172-2	2	WHEEL, 8.5" FOAM FILL
16	281200	1	DRAG CHAIN ASSY, FRAME
17	450076	1	CLAMP-CRIMP 185R SS
18	711383	4	NUT-HEX CLR LOC 5/16-18
19	711504	13	WSR-FLAT 1/4 ID SS
20	711512	2	WSR-FLAT .75X1.37X.08
21	711592	7	WSR-FLAT .506 X .9 X .064 NYL
22	711715	2	RETAINING RING EXT .75
23	711809	1	COTTER PIN, 1/8 X 1.0
24	711855	2	WSR-FLT .37X1.12X.10 STL Z HARD
25	712140	8	WSR-HELICAL 5/16 SS
26	712265	1	CLEVIS-YOKE, 1/2-20 W/ .375 PIN
27	712301	2	WSR-FLAT .37 X .87 X .06
28	712562	1	BOLT-HH 1/4-20X3/4 SS
29	712564	8	BOLT-HH 1/4-20X1.00 SS
30	712575	8	BLT-HH 5/16-18 X .75 SS
31	712758	14	WSR-HELICAL 1/4 SS
32	712760	1	WSR-FLAT .56X1.06X.04 SS
33	712772	14	WSR-FLAT .344 x .75 x .06 SS
34	713006	4	BLT-HH 1/4-20 X 1 3/4 #5
35	717026	2	SCR-SC SHCS M6X1.0 X 25 STL Z
36	747606	1	TRANSAXLE, ES1720 24V
37	809444	1	CLIP-CORD
38	833374	1	PIN, HAIRPIN COTTER 3/8
39	833833	1	PIN-CLEVIS 3/8 X 1.25
40	3400449	1	NUT-HEX JAM 1/2-20 ZP

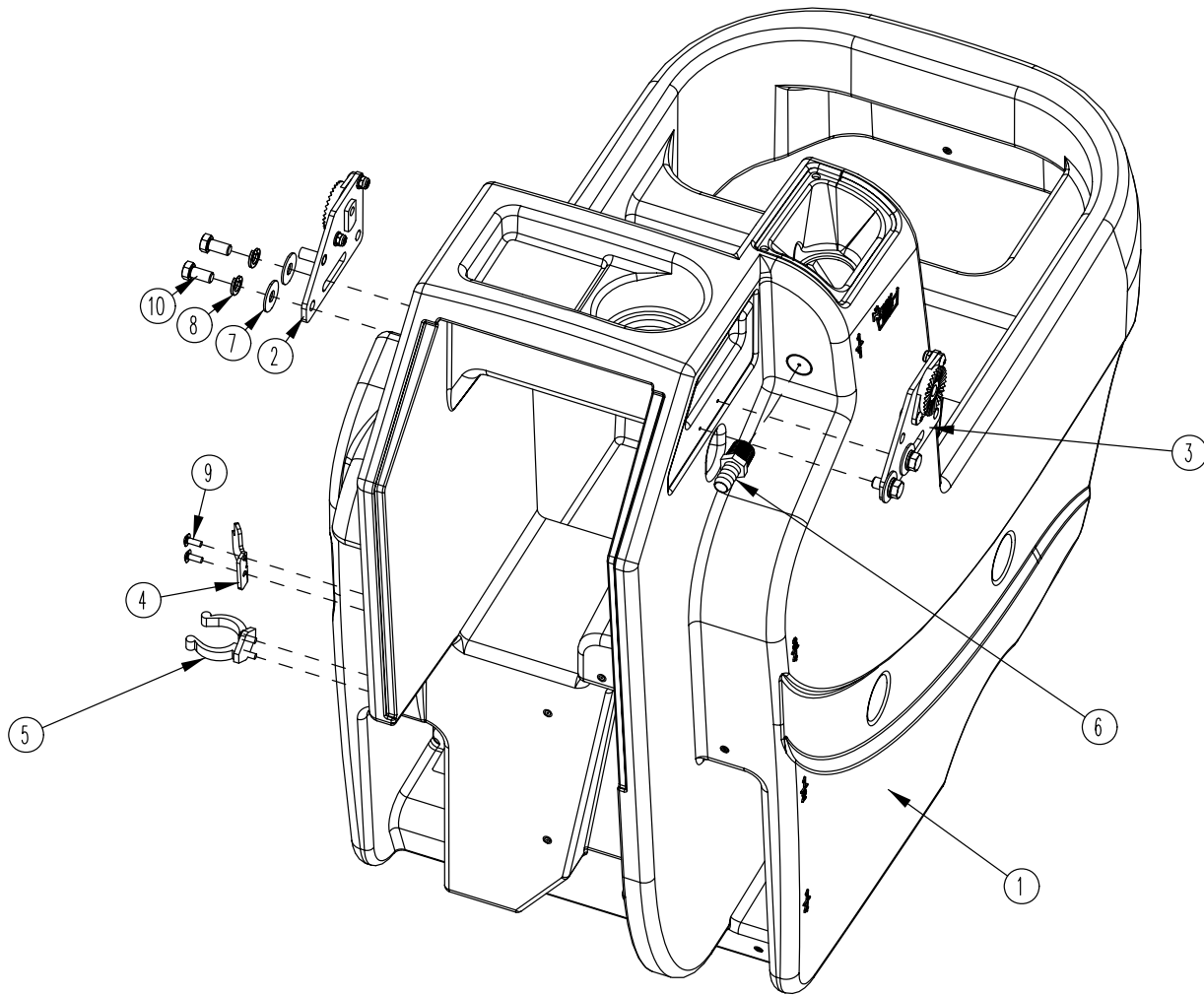

BILL OF MATERIAL - 172013			
ITEM	PART NO.	REQ'D	DESCRIPTION
1	172003	1	SOLUTION TANK
2	172080	1	HANDLE MOUNT ASSY, LEFT
3	172082	1	HANDLE MOUNT ASSY, RIGHT
4	172341	1	HOOK, DRAIN HOSE WITH TWIST VALVE
5	260579	1	TOOL CLIP, 1.5" HOSE
6	342438	1	FITTING, 1/2 MPT 1/2 HB BRASS
7	711507	4	WSR-FLAT .37 X 1.12 X .06
8	711546	4	WSR-HELICAL 3/8
9	712822	4	SCR-MC TR HD 10-24 X .50 SS
10	713041	4	BLT-HH 3/8-16 X 3/4 #5

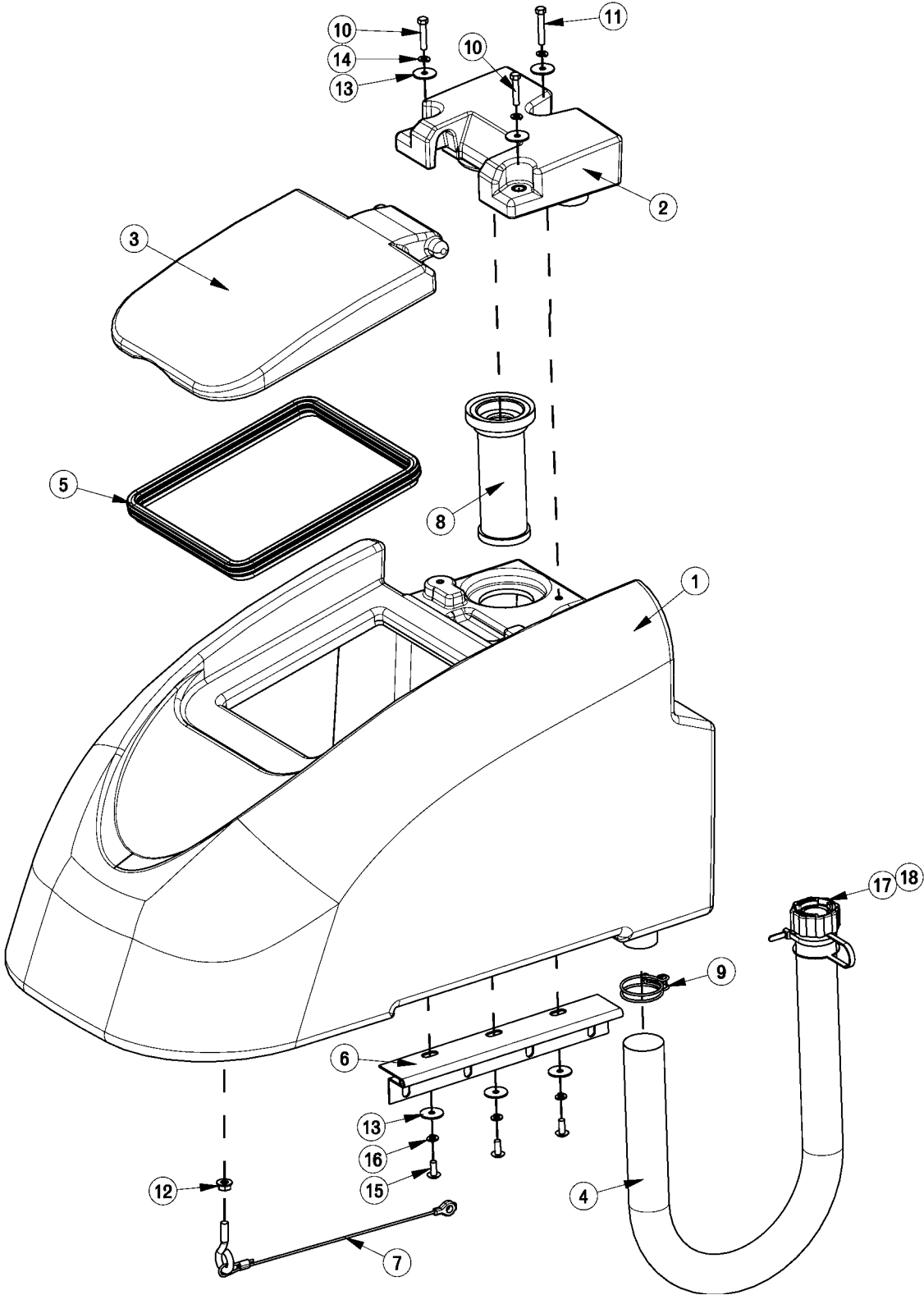

BILL OF MATERIAL - 172014			
ITEM	PART NO.	REQ'D	DESCRIPTION
1	172004	1	ES1720 RECOVERY TANK
2	172005	1	ES1720 VACUUM MANIFOLD
3	172007	1	ES1720 LID
4	97090096	1	DRAIN HOSE ASSY, RECOVERY TANK
5	172017	1	GASKET, LID
6	172049	1	HINGE, RECOVERY TANK
7	172394	1	REC TANK CABLE ASSY 11.625
8	172132	1	SCREENED FLOAT
9	172329	1	CLAMP-HOSE 1.56" 102122 MURRAY
10	711210	2	BLT-HH 1/4-20 X 1.25 STPL
11	711212	1	BLT-HH 1/4-20 X 1.50 STPL
12	711379	1	NUT, FLANGED WIZZ 5/16-18
13	711519	6	WSR- FLAT .25 X 1.01 X .06
14	711544	3	WSR-HELICAL 1/4
15	712565	3	SCR-MC 1/4-20X.63 SS TR HD
16	712758	3	WSR-HELICAL 1/4 SS
17	15282072	1	REPLACEMENT O-RING (NOT SHOWN)
18	90304528	1	REPLACEMENT CAP

# Handle Assembly

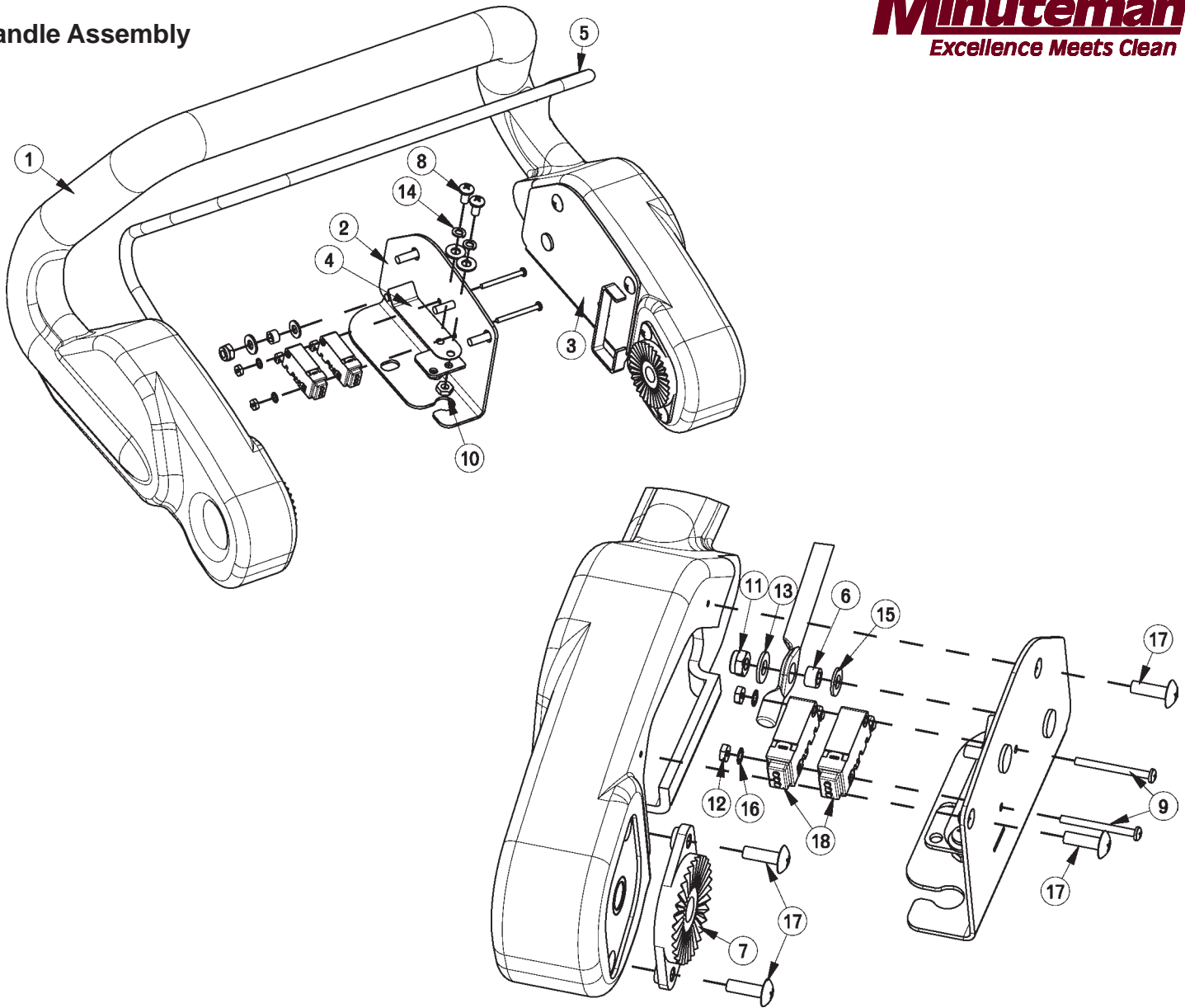

### BILL OF MATERIAL - 172015

ITEM	PART NO.	REQ'D	DESCRIPTION	ITEM	PART NO.	REQ'D	DESCRIPTION
1	172006	1	HANDLE	11	711350	2	NUT-NYLOC 10-32
2	172053	1	BAIL PLATE WMT RH	12	711428	2	NUT-HEX 4-40
3	172054	1	BAIL PLATE WMT LH	13	711503	6	WSR, FLAT #10
4	172057	2	LEAF SPRING	14	711543	4	WSR-HELICAL #10
5	172059	1	BAIL, HANDLE	15	712320	2	WSR-NYLON .22 X .45 X .04
6	172074	2	SPACER, 5/16OD X 17GA, ALUM	16	712326	2	WSR-INT LOCK #4
7	270143	2	HANDLE PIVOT JAW	17	712830	10	SCR-MC 10-24 X .62 STLZ TR HD
8	710353	4	SCR-MC RD HD 10-32 X .37 STL	18	747603-3	2	SWITCH ASY, MICRO ROLLER W/PACK/CONDUIT
9	710495	2	SCR-MC 4-40 X 1.25 STL Z	19	747715-1	1	CABLE ASY, 5 COND 18G TD
10	711310	4	NUT, HEX 10-32 ST PL				

## Pump Assembly

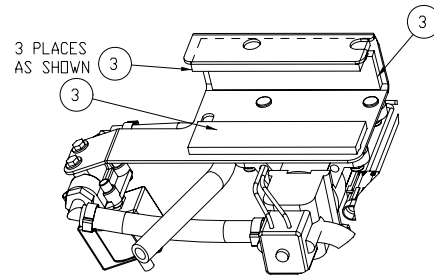
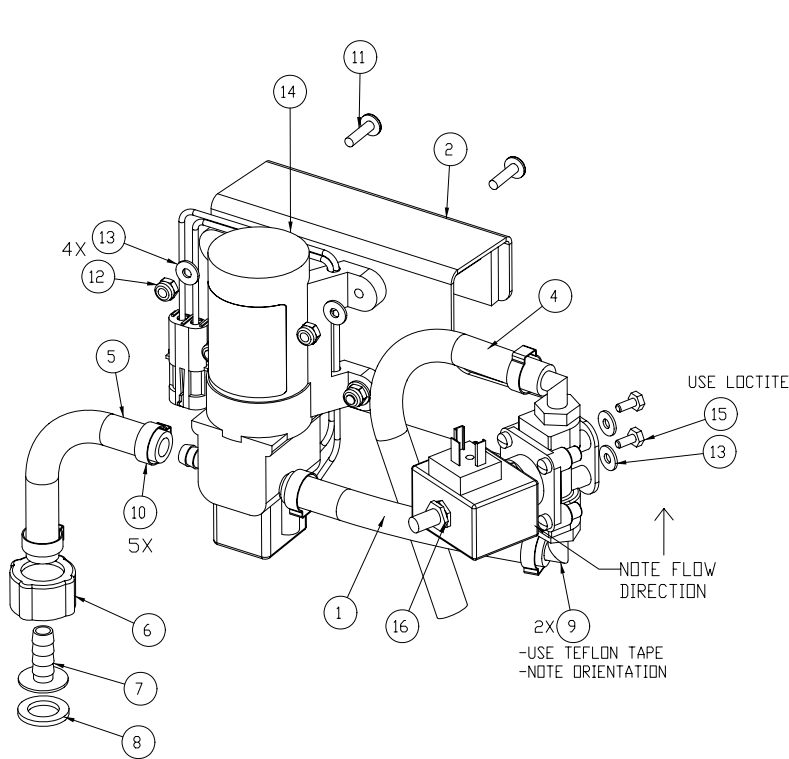

BILL OF MATERIAL - 172305			
ITEM	PART NO.	REQ'D	DESCRIPTION
1	172164	1	HOSE-WIRE REINF 3/8 X 5.5
2	172302	1	BKT , PUMP MOUNT
3	172304	3	FOAM .25 X 1.25 X 5 W/ ADH
4	241097	1	HOSE-WIRE REINF 3/8 X 31"
5	320254	1	HOSE-WIRE REINF 3/8 x 9"
6	342442	1	FITTING, FGHT NUT PP
7	342443	1	FITTING 3/8HB INSERT PP
8	342444	1	WSR-FILTER, GARDEN HOSE SIZE
9	450040	2	FITTING-90 3/8MPT X 3/8BARB NYLON
10	450076	5	CLAMP-CRIMP 185R SS
11	712537	4	10-24 X .75 SS TRUSS HD SCR
12	712638	4	NUT, HEX 10-24 SS NYLOC
13	712764	6	WSR #10 SS
14	747691	1	PUMP, 24VDC 35PSI 3/8HOSE w/CONNECTOR
15	11038965	2	BOLT-HH M4X0.7 X 10 Z DICH
16	90435595	1	WATER SOLENOID, 24VDC 2.5BAR

## Solution Valve Assembly

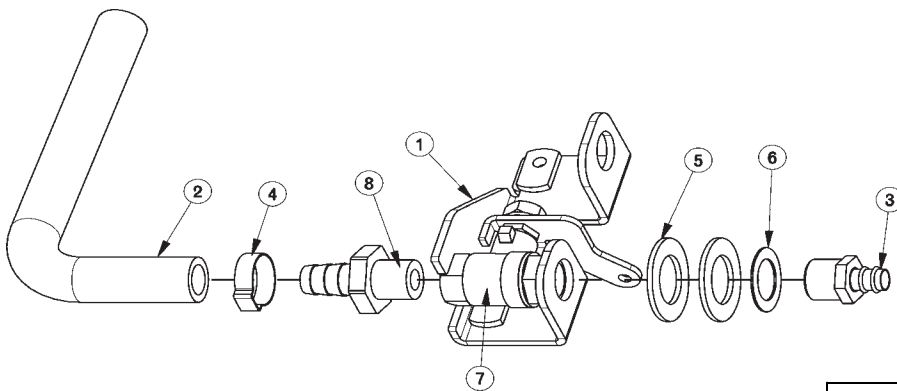

BILL OF MATERIAL - 172064			
ITEM	PART NO.	REQ'D	DESCRIPTION
1	172063	1	BKT, SOL VALVE MOUNT
2	172158	1	HOSE, 1/2"ID X 7.5" NYLOBRAID
3	320265	1	FITTING DUBL 3/8HBx3/8MPT
4	383347	1	CRIMP CLAMP 1/2 HOSE SS 185R
5	711512	2	WSR-FLAT .75X1.37X.08
6	711513	1	WSR-FLAT .69 X 1.06 X .03 SS
7	809415	1	VALVE, 3/8 FPT, 45 OPEN/CLOSE
8	827008	1	FITTING, 3/8 MPT 1/2 HOSE

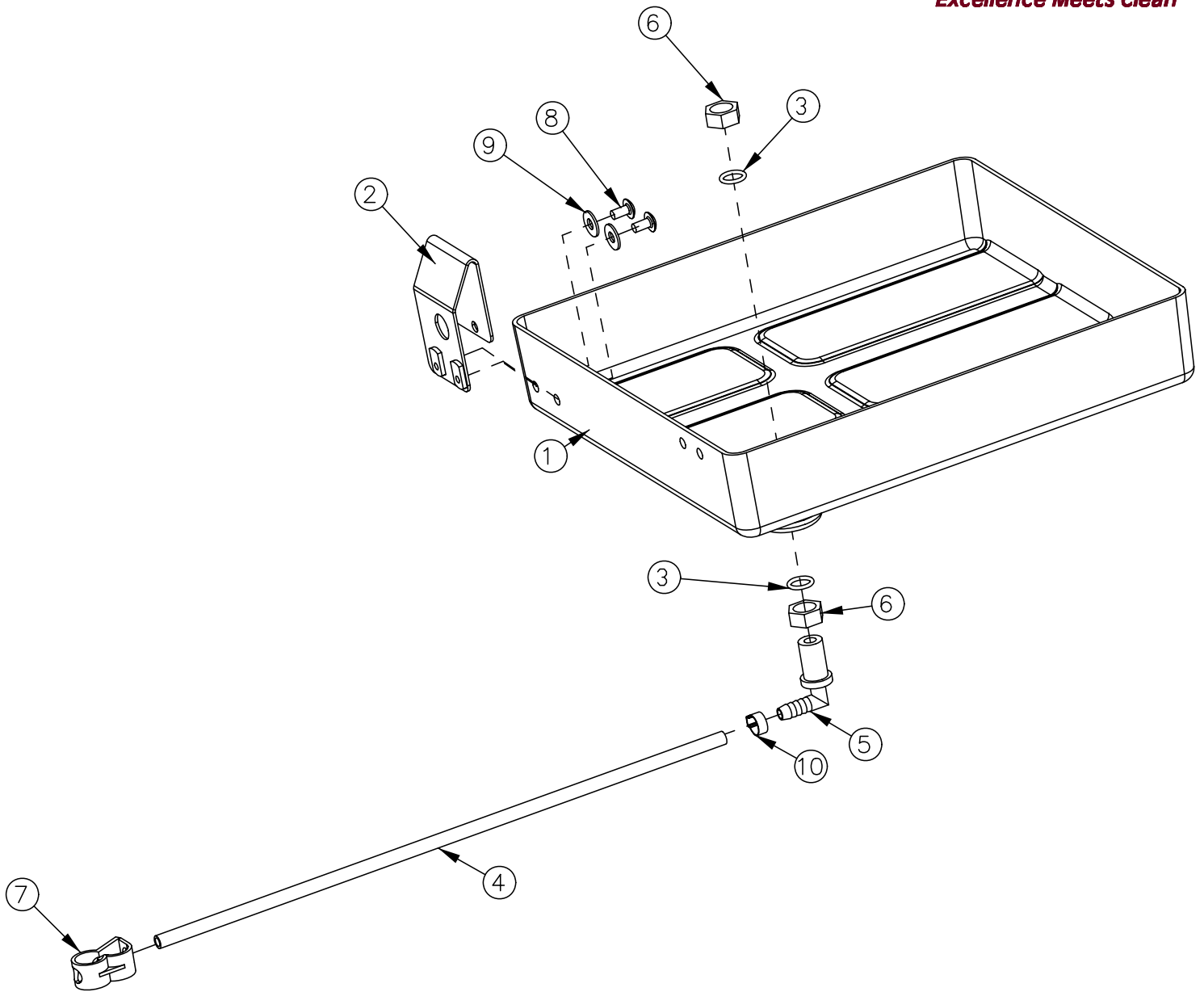

**BILL OF MATERIAL - 172012**

ITEM	PART NO.	REQ'D	DESCRIPTION
1	172116	1	BATTERY BOX
2	172213	1	BKT, SPACER FOR BATTERIES
3	210414	2	O RING 2-113
4	260224	1	18" HOSE
5	320271	1	NOZZLE BODY-ELBOW
6	320272	2	NOZZLE BODY LOCKNUT
7	320273	1	HOSE SHUT-OFF CLAMP
8	710178	2	SCR-MC 1/4-20 X .50 TRUSS STPL
9	711575	2	WSR-FLT .31x.75x.06ST
10	828490	1	CRIMP CLAMP 140R

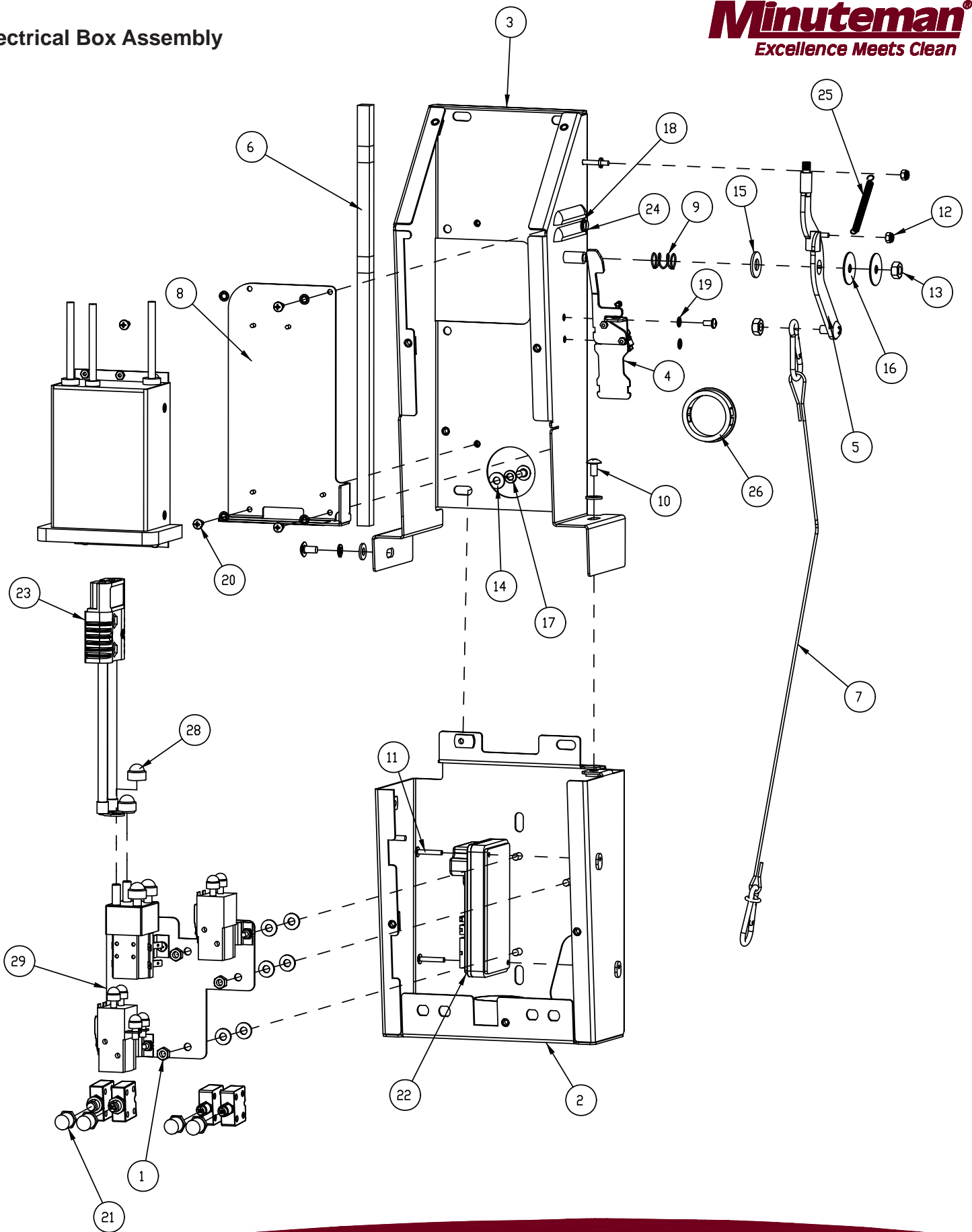

BILL OF MATERIAL - 172075C-120			
ITEM	PART NO.	REQ'D	DESCRIPTION
1	369-416	3	NUT-HEX 1/4-20 NYLOC SERATED
2	172077	1	ELEC BOX-BOT HALF WMT
3	172088	1	ELEC BOX-TOP HALF WMT
4	172141	1	VAC SWITCH ASSY
5	172152	1	VAC LEVER WMT
6	172188_	1	FOAM TAPE, 1/2" SQ X 16.5"
7	172381	1	CABLE ASSY, SQUEEGEE LIFT
8	172385	1	E1720 120V CHARGER ASSEMBLY
9	670093	1	SPRING, COMPRESSION
10	710178	3	SCR-MC 1/4-20 X .50 TRUSS ST PL
11	710534	2	SCR-MC TR HD 8-32 X 1.00 SS
12	711372	2	NUT-NYLOC 8-32 STL ZINC
13	711383	2	NUT-HEX CLR LOC 5/16-18
14	711505	9	1/4 FLAT WASHER, STEEL
15	711508	1	WSR-FLAT .44X 1.0X.08
16	711516	2	WSR- FLAT .31 X 1.25 X .05
17	711544	2	WSR-HELICAL 1/4
18	712320	2	WSR-NYLON .22 X .45 X .04
19	712770	6	WSR INT LOCK #10A SS
20	712810	6	SCR-MC 10-24 X .37 ST PL
21	742748	4	CIRCUIT BREAKER BOOT
22	747608	1	I-DRIVE,24V 70A PM MOTOR CONTROL
23	747637	1	WIRE ASY, MACHINE-BATTERY E1720
24	760134	2	MOUNT RING
25	762084	1	SPRING-EXT .25OD X 2" F.L. MUSIC
26	762400	1	HEYCO BUSHING 2.00"
27	828062	1	CABLE TIE LARGE (NOT SHOWN)
28	15592033	2	CAP, SAFETY NUT COVER M8
29	747670C	1	ELEC PANEL ASSY, E20C

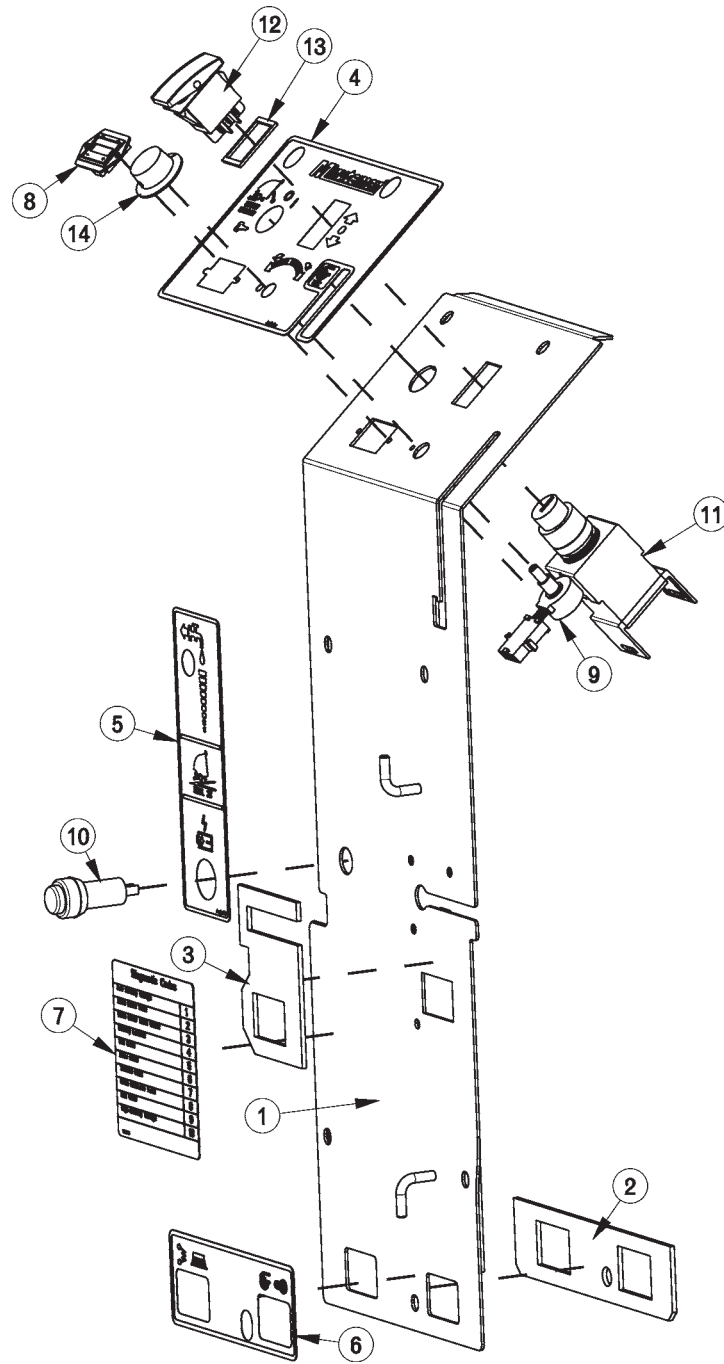

**BILL OF MATERIAL - 172330**

ITEM	PART NO.	REQ'D	DESCRIPTION			
				8	747011	1 BATTERY GAUGE, TRUCHARGE
1	172182	1	TD COVER WMT	9	747026	1 POTENTIOMETEOR ASSY SPEED CONTROL
2	172193	1	GASKET, CB OUTLINE	10	747614	1 CHARGE STATUS INDICATOR
3	172194	1	GASKET, CHARGER CORD PLATE	11	747617-3	1 KEYSWITCH ASY, KEYSWTICH + HAR
4	715680	1	DECAL, DASHBOARD E20 CYL	12	748201	1 SWITCH, DPDT ON/OFF/ON
5	715672	1	DECAL, CHARGE STATUS	13	748209	1 GASKET-FOR 2 POLE ROCKER SWITCHES
6	715674	1	DECAL, TD CIRCUIT BREAKER	14	809874	1 KNOB, SPEED CONTROL
7	715678	1	DECAL. DIAGNOSTIC CODES E1720TD			

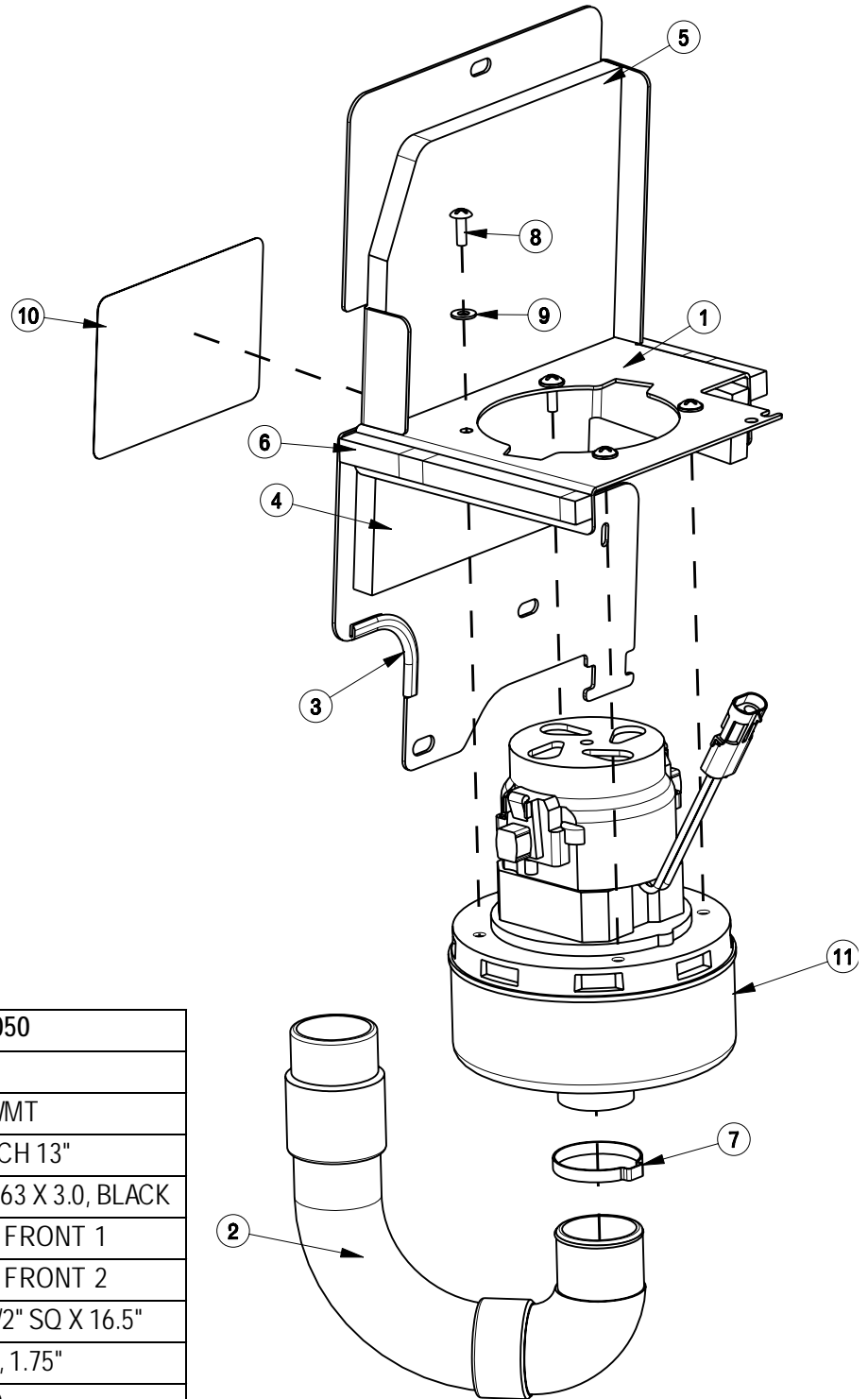

BILL OF MATERIAL - 172050

ITEM	PART NO.	REQ'D	DESCRIPTION
1	172045	1	VAC MOUNT WMT
2	172048	1	HOSE, STRETCH 13"
3	172124	1	EDGE TRIM, .063 X 3.0, BLACK
4	172186	1	FOAM COVER, FRONT 1
5	172187	1	FOAM COVER, FRONT 2
6	172188	2	FOAM TAPE, 1/2" SQ X 16.5"
7	450095	1	CRIMP CLAMP, 1.75"
8	711160	4	#10 X 5/8 HI-LO
9	711503	4	WSR, FLAT #10
10	715676	1	DECAL, BATT CABLE ROUTE
11	747607-1	1	VAC MOTOR ASY

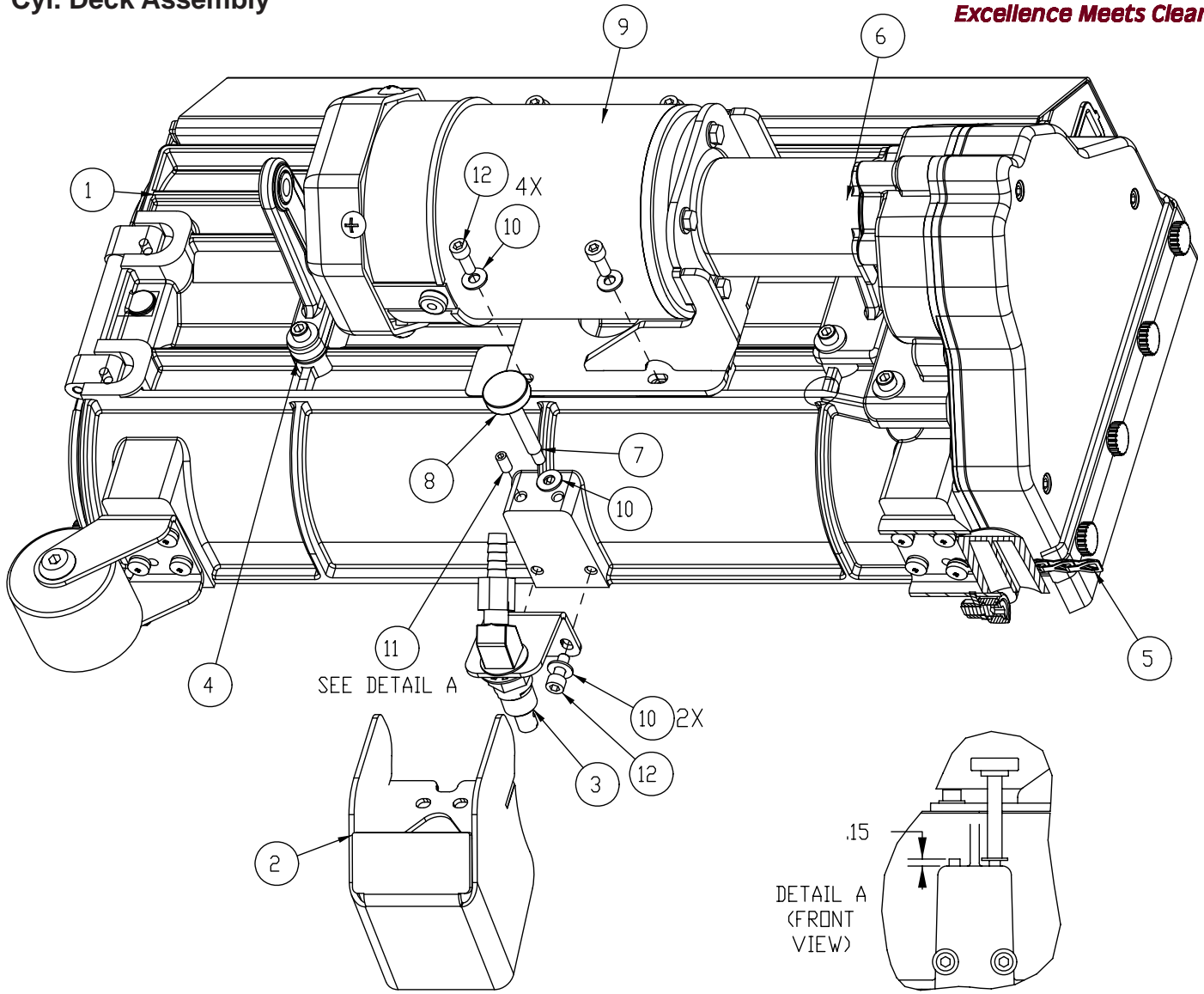

BILL OF MATERIAL - 172325			
ITEM	PART NO.	REQ'D	DESCRIPTION
1	172300	1	CYLINDRICAL SCRUBDECK
2	172307	1	SPRAYJET COVER WELDMENT
3	172312	1	SPRAY NOZZLE ASSY
4	172333	1	SPACER, CYL DECK MOUNT
5	172334	1	DRAG CHAIN, CYL. SCRUBDECK
6	172345	1	L-070 LOVEJOY COUPLER
7	172349	1	BLT- SHLDR .31 X .375 X 1/4-20
8	172353	1	KNOB, KNURLED
9	172355	1	CYL MOTOR ASM
10	711504	7	WSR-FLAT 1/4 ID SS
11	712160	1	SCR-SK, M6 X 12 SS CUP PT
12	11132065	6	SCR-SC, M6X1.0 X 16 Z DICH

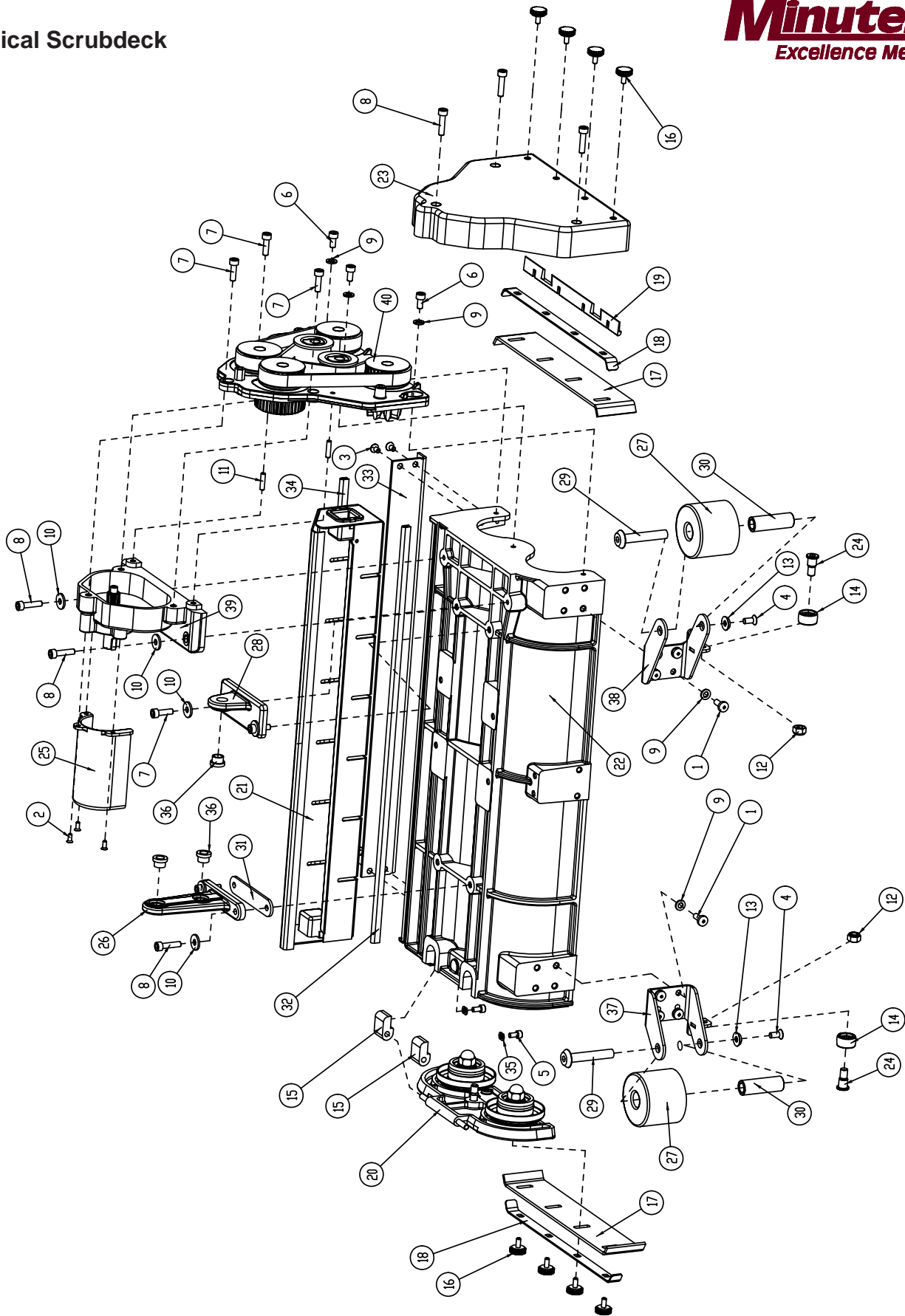

BILL OF MATERIAL - 172300			
ITEM	PART NO.	REQ'D	DESCRIPTION
1	817306	8	SCR-PAN HD M6x16
2	829103	3	SCR-MC FL HD M4 X 10 SS
3	829203	4	CR-CSK-SCREW-M5X10-SS
4	829321	2	SC-FHCS M6 X 14 SS
5	831203	2	SCR-SHCS, M5X10 ZP
6	831304	3	SCR-SHCS, M6X12 ZP
7	831307	5	SCR-SHCS, M6X20 ZP
8	831308	7	SCR-SHCS, M6X25 ZP
9	844061	11	WASHER-6_4X12X1_6
10	844063	6	WASHER-6_4X18X2
11	853508	2	DOWEL PIN
12	859086	2	NUT-NYLOC M8
13	925012	2	WASHER-BRIDGE
14	931163	2	WHEEL - BRUSH
15	931171	2	HINGE-IDLER END
16	931172	8	KNOB-SQG
17	931235	2	LIP-FLASH GUARD
18	3130024	2	STRIP-FLASH GUARD
19	3130110	1	SEAL-BELT COVER
20	3180062	1	IDLER SUPPORT ASSLY BRUSH
21	3180217	1	DEBRIS TRAY
22	3530278	1	BRUSH DECK HOUSING
23	3530280	1	BELT COVER
24	3530283	2	PIN-BRUSH WHEEL
25	3530287	1	COUPLER COVER
26	3530288	1	BRACKET - DOUBLE ARM
27	3530290	2	DEFLECTOR ROLLER
28	3530291	1	BRACKET - SINGLE ARM
29	3530292	2	DEFLECTOR ROLLER STUD
30	3530296	2	SLEEVE DEFLECTOR ROLLER
31	3530346	1	SPACER, DOUBLE ARM
32	3530358	1	STRIP HOUSING U BEEDING
33	3530359	1	SUPPORT PLATE HOUSING
34	3530361	1	STRIP HOUSING U BEEDING
35	3530362	2	SPECIAL WASHER M5
36	3530408	3	BUSHING-FLG, .375X.50X.31 GFS-055
37	3580215	1	DEFLECTOR ROLLER ARM RH WELDMENT
38	3580216	1	DEFLECTOR ROLLER ARM LH WELDMENT
39	3580219	1	HOUSING - GEAR ASSY
40	3580257	1	HOUSING ASSY-GEAR SUPPORT

Cylindrical Scrubdeck  
SubAssy I - Idler Support

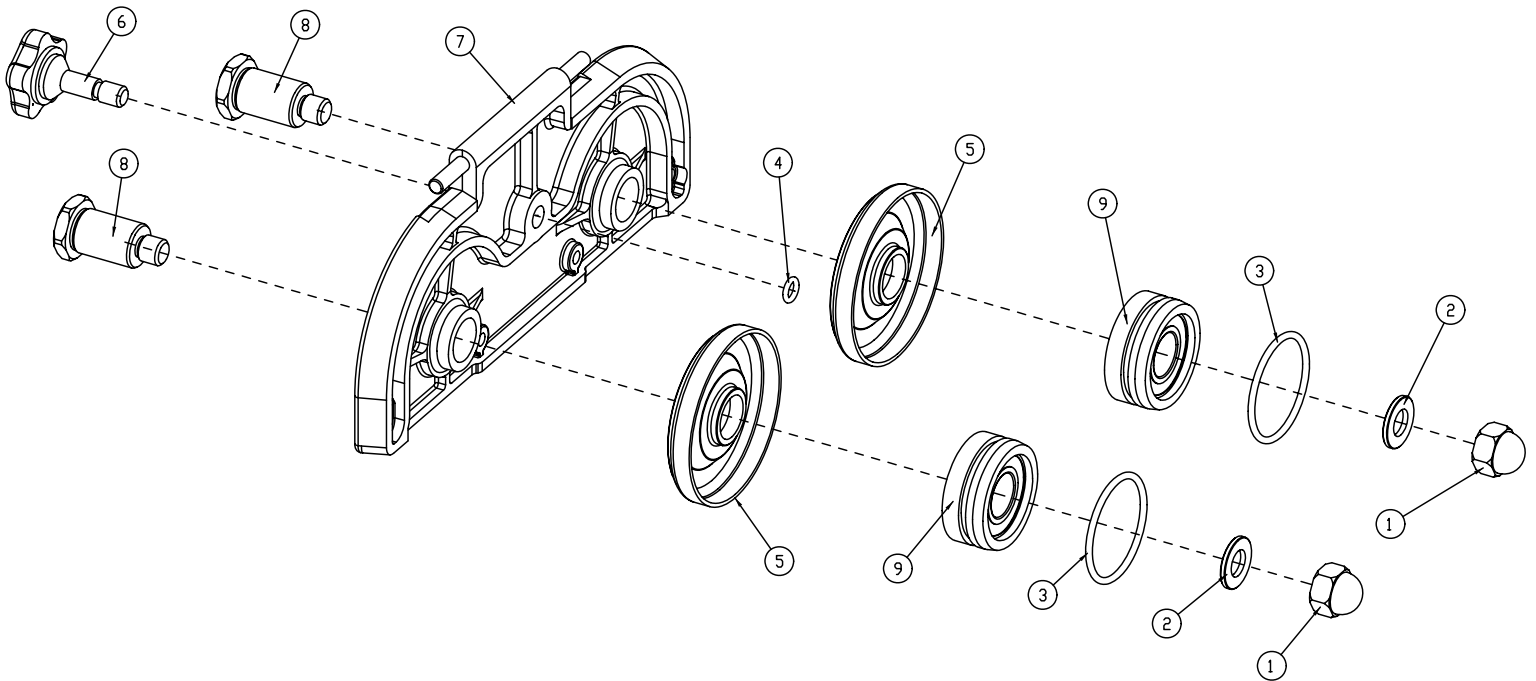

BILL OF MATERIAL - 3180062			
ITEM	PART NO.	REQ'D	DESCRIPTION
1	838100	2	DOMED CAP NUT-M10-SS
2	845101	2	WASHER-SS-304-10.5X20X2
3	854007	2	O' RING - 36X2.5
4	854008	1	ORING 6X2.0
5	931157	2	SPACER, IDLER HUB COVER
6	931758	1	KNOB-IDLER COVER LOCK
7	3130005	1	COVER IDLER END -MACHINING
8	3130042	2	PIN-IDLER END
9	3180091	2	IDLER PULLEY - BRUSH

**Cylindrical Scrubdeck  
SubAssy II - Gear Support**

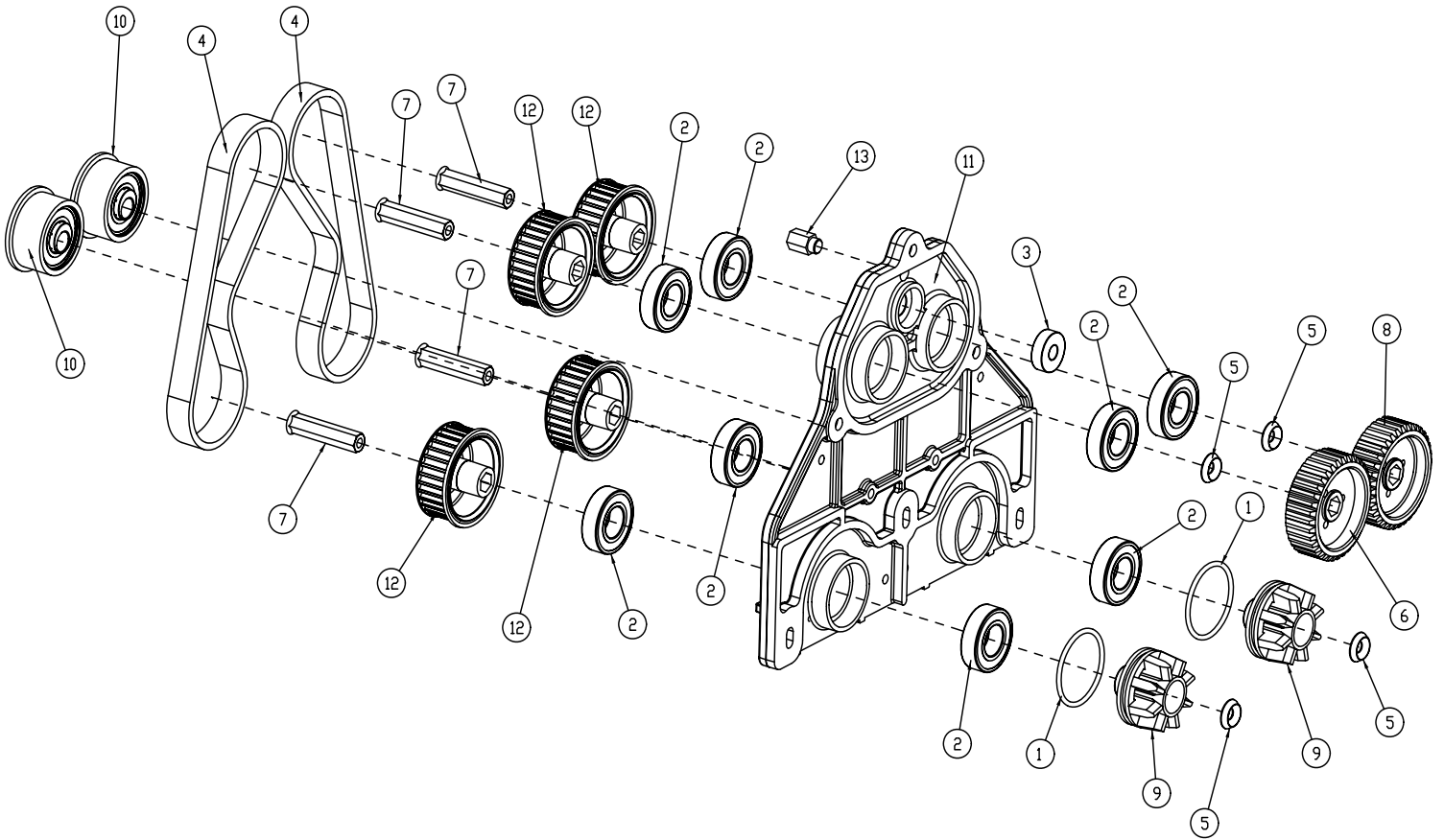

BILL OF MATERIAL - 3580257			
ITEM	PART NO.	REQ'D	DESCRIPTION
1	854007	2	O' RING - 36X2.5
2	875010	8	BEARING-6003 NSE NACHI
3	875011	1	BEARING-608 2Z
4	925002	2	DRIVE BELT 425-5M-15-HTD
5	925012	4	WASHER-BRIDGE
6	925193	1	GEAR-LH
7	931027	4	DRIVE KEY
8	931035	1	GEAR-RH
9	931129	2	PULLEY-DRIVE
10	931815	2	IDLER-PLAIN ASSY
11	3130006	1	HOUSING-GEAR SUPPORT
12	3180008	4	SPROCKET ASSEMBLY-GEAR
13	3530372	1	STUD-M/F, M8/M6 ZP

# E20 Rear Squeegee Assembly

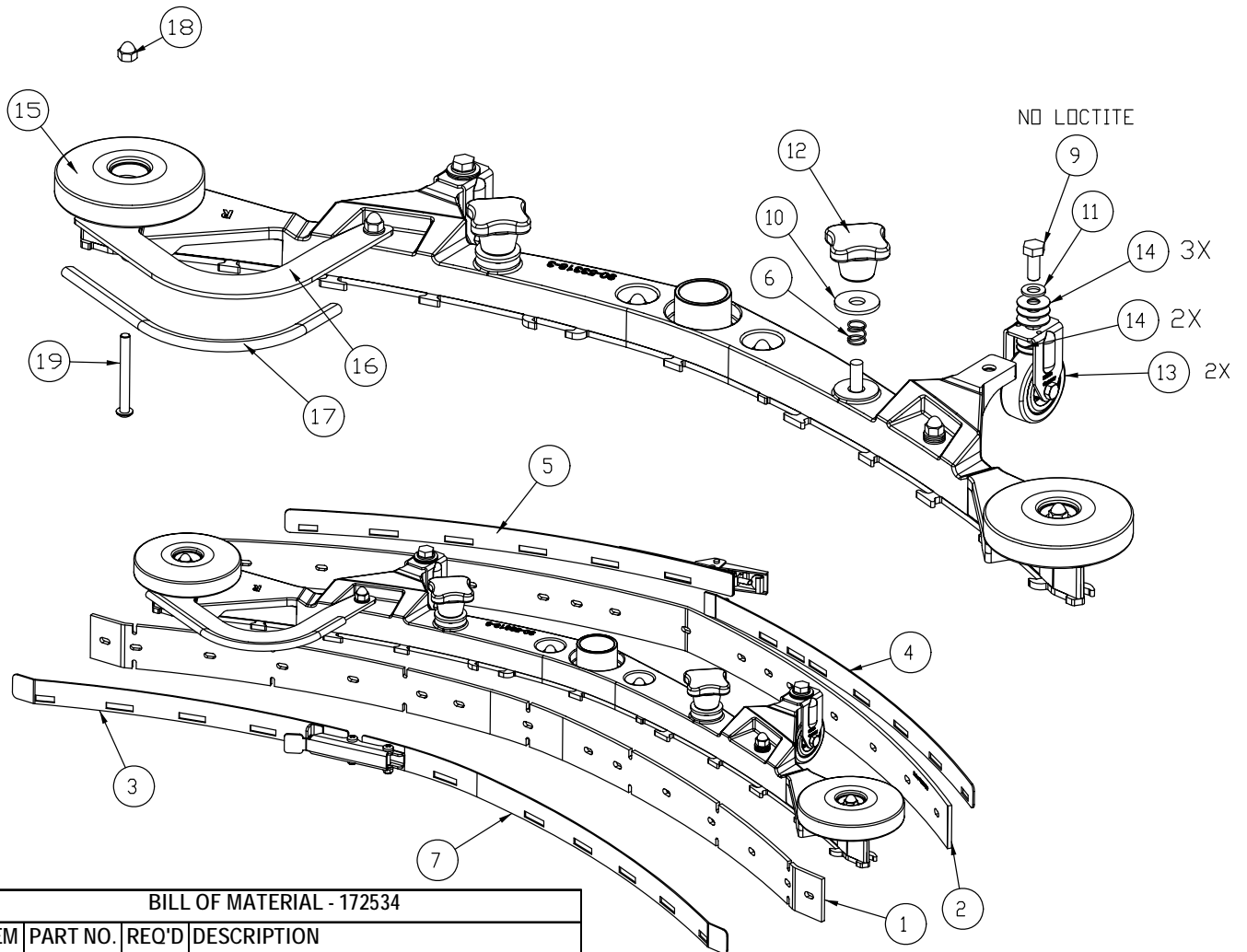

**BILL OF MATERIAL - 172534**

ITEM	PART NO.	REQ'D	DESCRIPTION
1	172162	1	BLADE, FRONT 34" SQUEEGEE
2	172163	1	BLADE, REAR 34" SQUEEGEE
3	172241	1	STRAP WMT, FRONT
4	172245	1	STRAP WMT, REAR
5	172246	1	STRAP WMT, REAR
6	172429	2	SPRING, COMPRESSION
7	172440	1	TENSION BAND ASM, FRONT LEFT 34"
8	172535	1	SQG BASE ASSEMBLY 34"
9	717030	2	BOLT-HH M8X1.25 X 20 SS
10	717040	2	WSR-FLT 10.5 X 30 X 2.5 SS
11	12310264	2	WSR-FLT M8.4X16X1.6 SS
12	17133026	2	KNOB, M10 STAR HANDLE
13	90513094	2	FIXED CASTOR
14	90531112	10	WSR-FLT 8.3 X 22 X 1MM SS
15	90548397	2	ROLLER - PLASTIC, 100mm DIA (4"), BLACK
16	172271	1	BUMPER, 34" SQG
17	172274	1	EDGE TRIM, 5/16 X 10" BLACK
18	712591	6	NUT, ACORN 1/4-20 SS
19	712592	2	SCR-MC BHCS, 1/4-20 X 2.25 SS

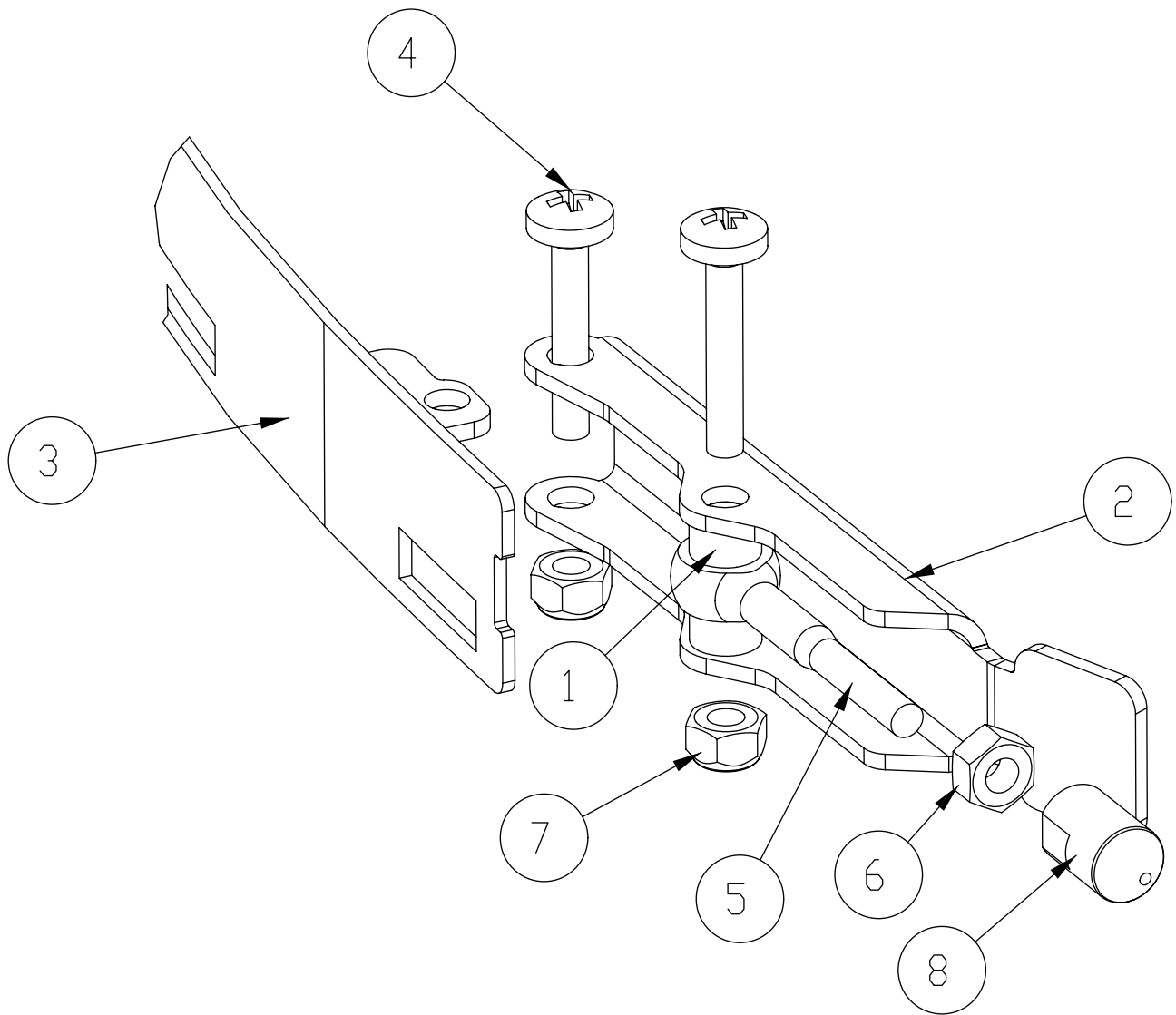

BILL OF MATERIAL - 172440			
ITEM	PART NO.	REQ'D	DESCRIPTION
1	172074	2	SPACER, 5/16OD X 17GA, ALUM
2	172234	1	LEVER, 90535758
3	172240	1	STRAP WMT, FRONT LEFT
4	11175494	2	SCR-MC M5 X 25 SS DIN7985
5	11518313	1	BLT-EYE M5 X 40 SS
6	12022430	1	NUT - HEX, M5, SS DIN934
7	12040283	2	NUT - HEX, M5 NYLON LOCK, SS DIN985
8	90513631	1	PIN, THD 90513631

# Squeegee Mechanism Assembly

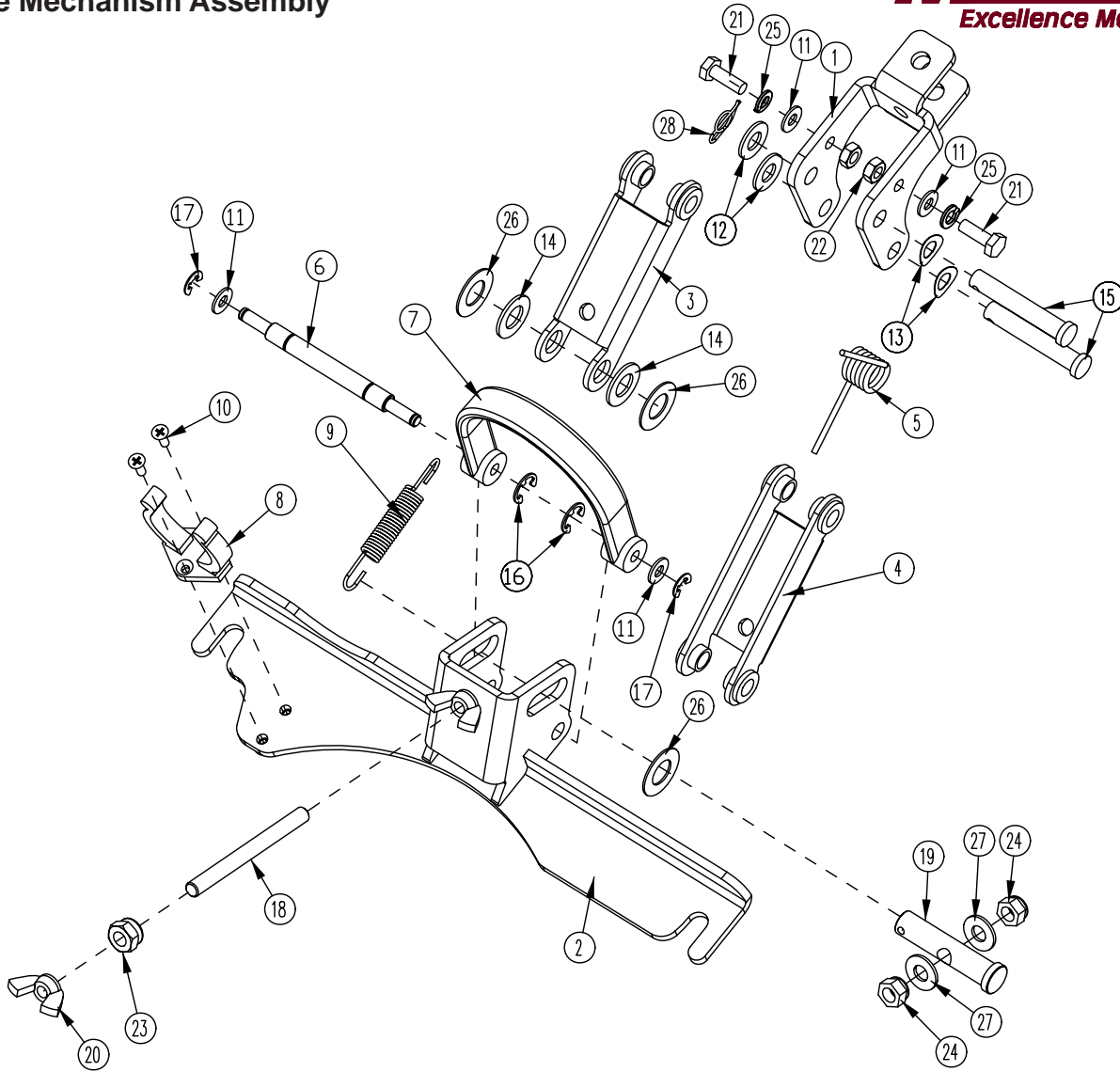

**BILL OF MATERIAL - 172150**

ITEM	PART NO.	REQ'D	DESCRIPTION	ITEM	PART NO.	REQ'D	DESCRIPTION
1	172134	1	BKT, MAIN SQUEEGEE HINGE	15	711678	2	CLEVIS PIN 3/8 X 2-1/4
2	172155	1	SQUEEGEE MOUNT WMT	16	711717	2	RETAINING RING- E TYPE .37
3	172196	1	SQ TOP LINK W/ BUSHING	17	711720	2	.250 DIA RETAINING RING- E TYPE
4	172197	1	SQ BOT LINK W/ BUSH	18	712147	1	ROD-THD 5/16-18 X 3.5 SS
5	172261	1	TORSION SPRING	19	712148	1	CLEVIS PIN, 1/2 x 2.25 W/ HOLE
6	172352	1	PIN, 3/8 X 3.0, SQG STRAP	20	712157	2	NUT- WING 5/16-18 SS
7	172357	1	STRAP, 9" PU, BLACK	21	712562	2	BOLT-HH 1/4-20X3/4 SS
8	260579	1	TOOL CLIP, 1.5" HOSE	22	712665	2	NUT-HEX 1/4-20 SS
9	430051	1	RETURN SPRING-3.00"	23	712680	1	NUT-HEX 5/16-18 SS
10	710530	2	SCR-MC FL HD 8-32 X .50 BRS	24	712683	2	NUT, HEX 5/16-18 NYLOC SS
11	711504	4	WSR-FLAT 1/4 ID SS	25	712758	2	WSR-HELICAL 1/4 SS
12	711515	2	WSR-FLAT .406 X .812 X .0625	26	712760	3	WSR-FLAT .56X1.06X.04 SS
13	711523	2	WSR-WAVE .37X .68 X .08	27	712772	2	WSR-FLAT .344 x .75 x .06 SS
14	711592	2	WSR-FLAT .506 X .9 X .064 NYL	28	3400125	1	PIN-COTTER 3/8 RUE RING

# 1 Wiring Diagrams

PAGE LAYOUT

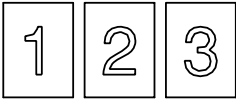

PAGES GO TOGETHER AS SHOWN TO SEE THE ENTIRE SCHEMATIC AS ONE.

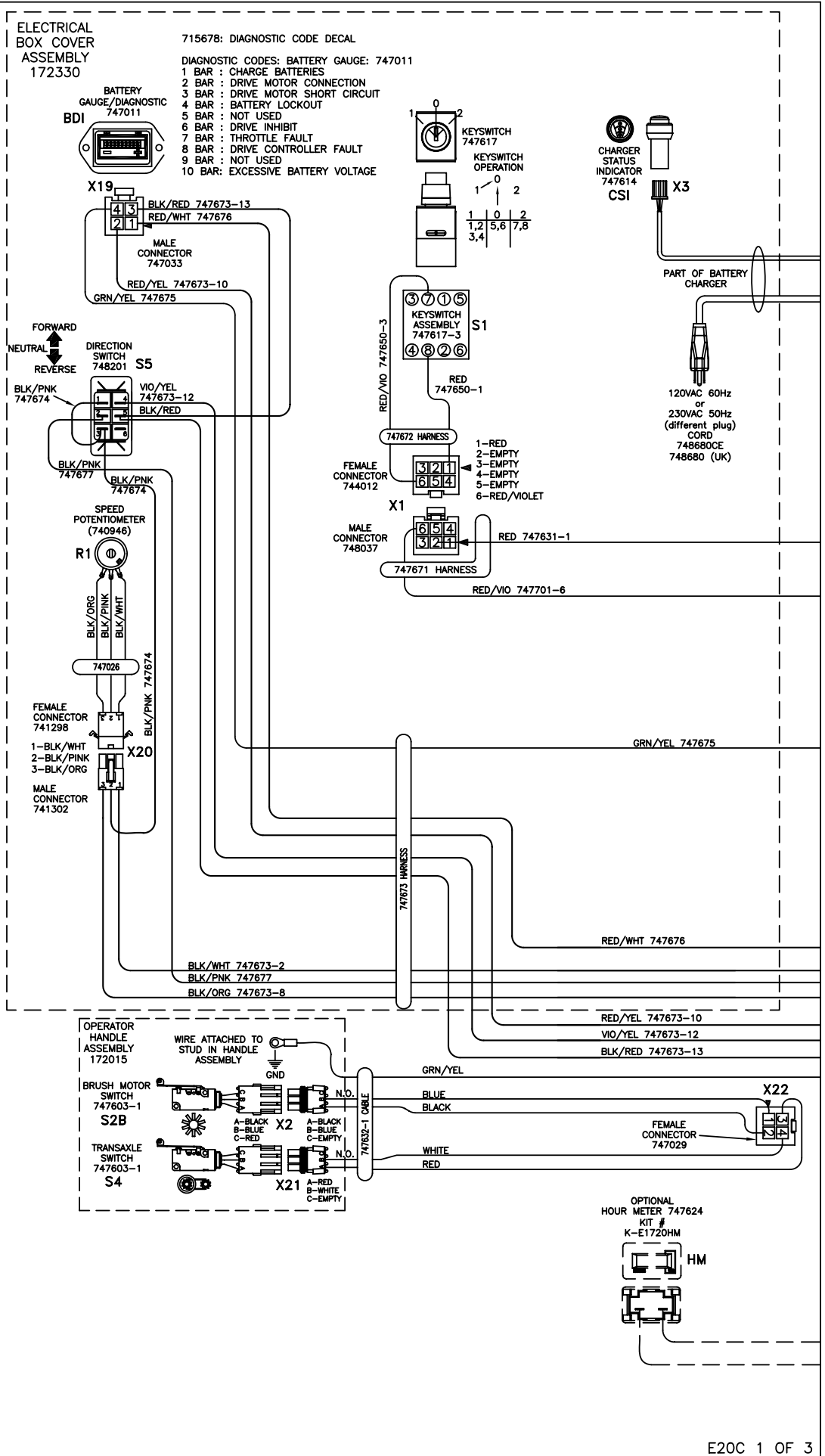

ELECTRICAL  
BOX ASSEMBLY  
172075C-120  
172075C-230

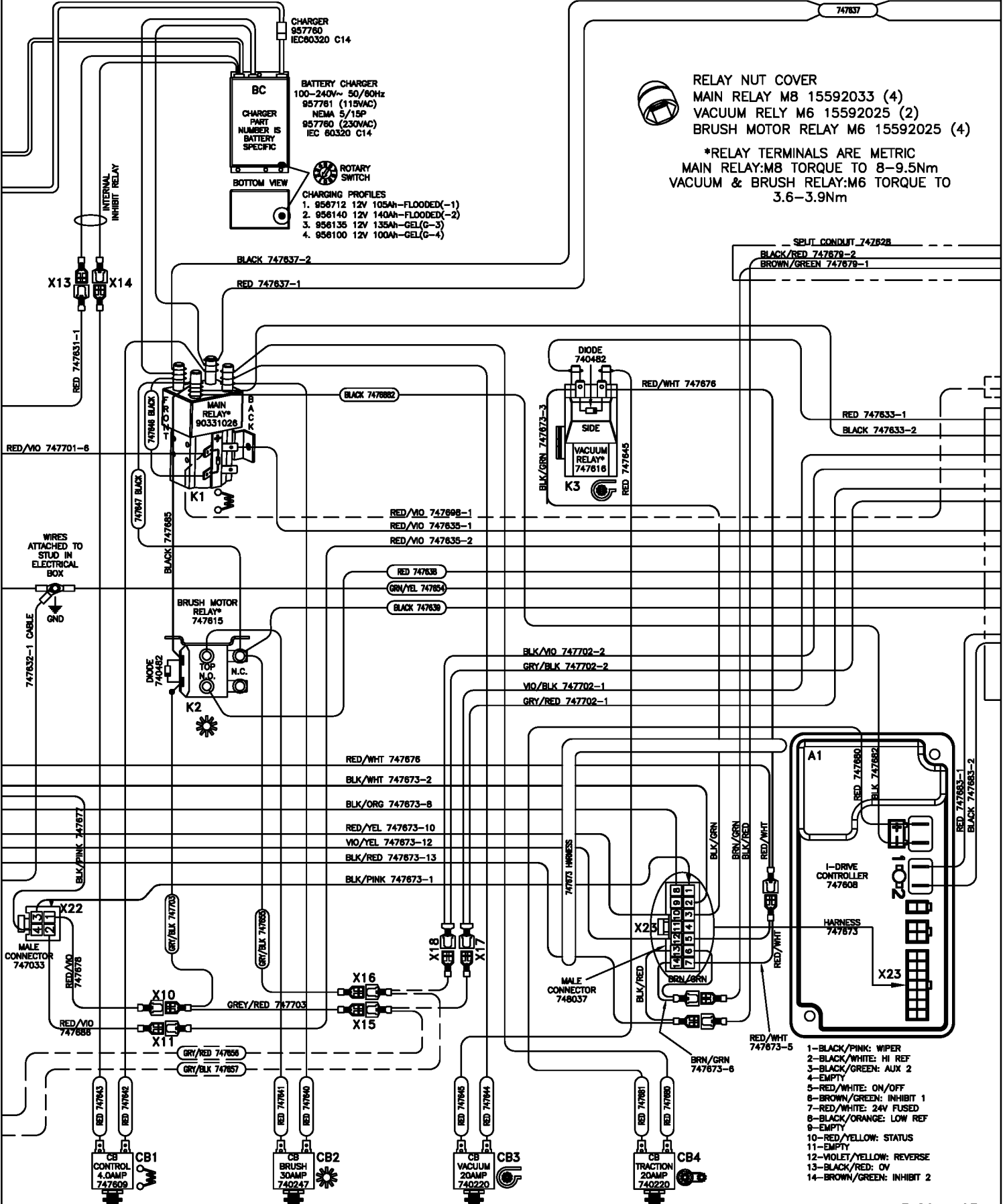

RELAY NUT COVER  
 MAIN RELAY M8 15592033 (4)  
 VACUUM RELY M6 15592025 (2)  
 BRUSH MOTOR RELAY M6 15592025 (4)

\*RELAY TERMINALS ARE METRIC  
 MAIN RELAY:M8 TORQUE TO 8-9.5Nm  
 VACUUM & BRUSH RELAY:M6 TORQUE TO 3.6-3.9Nm

CHARGER  
957760  
IEC60320 C14

BC  
BATTERY CHARGER  
100-240V~ 50/60Hz  
957761 (115VAC)  
NEMA 5/15P  
957760 (230VAC)  
IEC 60320 C14

CHARGING PROFILES  
 1. 956712 12V 105Ah-FLOODED(-1)  
 2. 956140 12V 140Ah-FLOODED(-2)  
 3. 956135 12V 135Ah-GEL(C-3)  
 4. 956100 12V 100Ah-GEL(C-4)

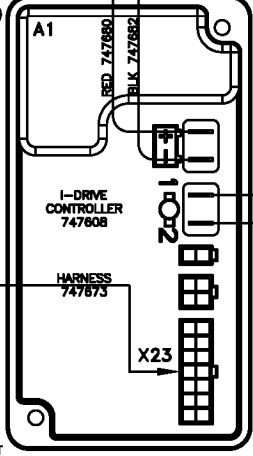

- 1-BLACK/PINK: WIPER
- 2-BLACK/WHITE: HI REF
- 3-BLACK/GREEN: AUX 2
- 4-EMPTY
- 5-RED/WHITE: ON/OFF
- 6-BROWN/GREEN: INHIBIT 1
- 7-RED/WHITE: 24V FUSED
- 8-BLACK/ORANGE: LOW REF
- 9-EMPTY
- 10-RED/YELLOW: STATUS
- 11-EMPTY
- 12-VIOLET/YELLOW: REVERSE
- 13-BLACK/RED: OV
- 14-BROWN/GREEN: INHIBIT 2

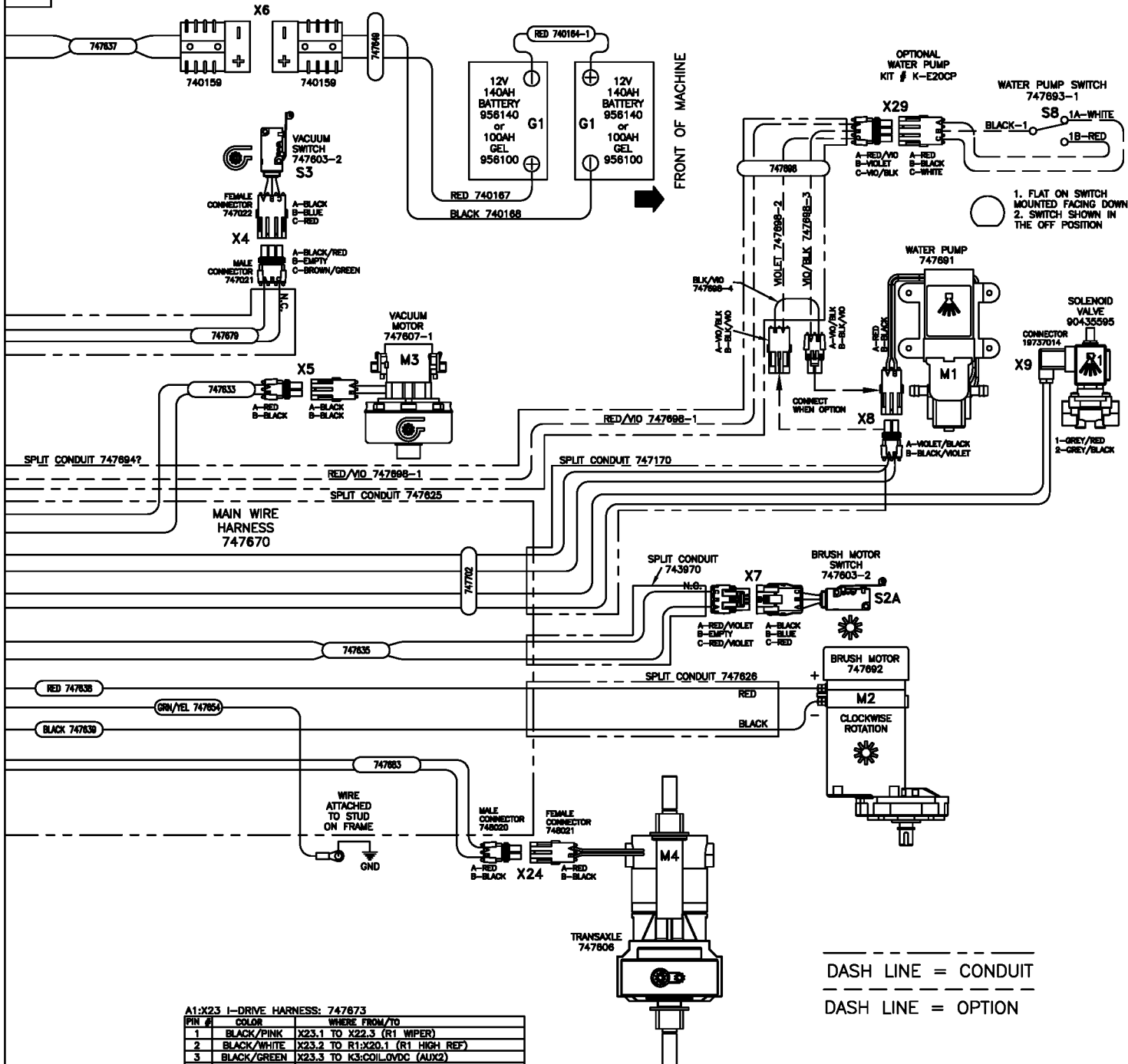

A1:X23 I-DRIVE HARNESS: 747873

PIN #	COLOR	WHERE FROM/TO
1	BLACK/PINK	X23.1 TO X22.3 (R1 WIPER)
2	BLACK/WHITE	X23.2 TO R1:X20.1 (R1 HIGH REF)
3	BLACK/GREEN	X23.3 TO K3:COIL OVDC (AUX2)
4	EMPTY	-
5	RED/WHITE	X23.5 JUMPER TO X23.7 (ON/OFF)
6	BROWN/GREEN	X23.6 JUMPER TO X23.14 (INHIBIT 1)
7	RED/WHITE	X23.7 JUMPER TO X23.5 (24VDC FUSED)
8	BLACK/ORANGE	X23.8 TO R1:X20.3 (R1 LOW-REF)
9	EMPTY	-
10	RED/YELLOW	X23.10 TO BD1:X19.2 (STATUS)
11	EMPTY	-
12	VIOLET/YELLOW	X23.12 TO S5.4 (REVERSE)
13	BLACK/RED	X23.13 JUMPER S5.5 JUMPER BD1:X19.3 (OV)
14	BROWN/GREEN	X23.14 JUMPER TO X23.6 (INHIBIT 2)

R1:X20 SPEED POTENTIOMETER: 747026

COLOR	WHERE FROM/TO
1	BLACK/WHITE X20.1 TO A1:X23.2
2	BLACK/PINK X20.2 TO S5.3 JUMPER S5.1
3	BLACK/ORANGE X20.3 TO A1:X23.8

X22: OPERATOR HANDLE CABLE: 747632-1

COLOR	WHERE FROM/TO
1	BLUE X22.1 TO S2B:X2.B
2	BLACK X22.2
3	RED X22.3 TO S4:X21.A
4	WHITE X22.4 TO S4:X21.B

X22: CONNECTOR TO OPERATOR HANDLE CABLE: 747632-1

COLOR	WHERE FROM/TO
1	RED/VIOLET X22.1 TO X10 JUMPER K2:COIL 24VDC JUMPER X15
2	RED/VIOLET X22.2 TO X11 TO S2A:X7.A
3	BLACK/PINK X22.3 TO A1:X23.1
4	BLACK/PINK X22.4 TO S5.2

S1:X1 MAIN KEYSWITCH ASSEMBLY: 747617-1

PIN #	COLOR	WHERE FROM/TO
1	RED	X1.1 TO X13 BC INTERNAL RELAY
2	EMPTY	-
3	EMPTY	-
4	EMPTY	-
5	EMPTY	-
6	RED/VIOLET	X1.1 TO K1:COIL 24VDC

BATTERY CHARGER: 957745 or 957753

COLOR	WHERE FROM/TO
X13	RED X13 TO S1:X1.1
X14	BLACK X14: CB1 CONTROL 4.0A
14GA	RED K1:CONTACT + (REAR LEFT POST)
14GA	BLACK K1:CONTACT - (FRONT LEFT POST)

OTHER WIRE COLORS

RED	BATTERY 24VDC: +
BLACK	BATTERY OVDC: -
GREEN/YELLOW	GROUND
RED/VIOLET	24VDC AFTER MAIN KEYSWITCH
X15	GREY/RED OPTIONAL POWER 24VDC: 4A MAX
X16	GREY/BLACK OPTIONAL POWER OVDC: 4A MAX
X8A	VIOLET/BLACK WATER PUMP: 24VDC
X8B	BLACK/VIOLET WATER PUMP: OVDC
X9A	VIOLET/BLACK WATER SOLENOID VALVE: 24VDC
X9B	BLACK/VIOLET WATER SOLENOID VALVE: OVDC

E20C PART REFERENCE LIST  
Schematic 745096

REFERENCE #	COMPONENT NAME	PART NUMBER
M1	PUMP, WATER	748691
M2	MOTOR, BRUSH	748692
M3	MOTOR, VACUUM ASSEMBLY	747607-1
M4	TRANSAXLE	747606
Y1	SOLENOID VALVE, WATER	90435595
K1	RELAY, MAIN	90331026
K2	RELAY, BRUSH MOTOR	747615
K3	RELAY, VACUUM	747616
CB1	CIRCUIT BREAKER 4.0A, CONTROL	747609
CB2	CIRCUIT BREAKER 30A, BRUSH MOTOR	740247
CB3	CIRCUIT BREAKER 20A, VACUUM MOTOR	740220
CB4	CIRCUIT BREAKER 20A, TRANSAXLE	740220
S1	KEYSWITCH	747617
S2A	SWITCH, BRUSH MOTOR (at motor)	747603-2
S2B	SWITCH, BRUSH MOTOR (handle)	748603-1
S3	SWITCH, VACUUM MOTOR	748603-2
S4	SWITCH, TRANSAXLE (handle)	748603-1
S5	SWITCH, DIRECTION	748201
S8 (optional)	SWITCH, PUMP- OFF AISLE WAND (KIT K-E20CP)	747693-1
A1	CONTROLLER, I-DRIVE	747608
R1	SPEED POTENTIOMETER ASSEMBLY	747026
BDI	BATTERY DISCHARGE INDICATOR	747011
CSI	CHARGER STATUS INDICATOR	747614
HM (optional)	HOUR METER (KIT K-E1720HM)	747624
BC (model specific)	BATTERY CHARGER 115VAC (battery type specific)	957761 (-2 or G-4)
BC (model specific)	BATTERY CHARGER 230VAC (battery type specific)	957760 (-2 or G-4)
G1	BATTERY, 12V 140AH (2 REQUIRED)	956140
G1 (optional)	BATTERY, GEL 12V 100AH (2 REQUIRED)	956100
D1	DIODE, MAIN RELAY	Part of K1
D2	DIODE ASM, BRUSH MOTOR RELAY	740482
D3	DIODE ASM, VACUUM MOTOR RELAY	740482

REFERENCE #	CONNECTOR FUNCTION	PART # -female	PART # -male
X1	KEYSWITCH (S1)	744012	748037
X2	SWITCH, BRUSH MOTOR (S2B)	747022	747021
X3	CHARGER STATUS INDICATOR (CSI)	Part of CSI	Part of BC
X4	SWITCH, VACUUM (S3)	747022	747021
X5	MOTOR, VACUUM (M3)	748021	748020
X6	BATTERY CONNECTOR	740159	740159
X7	SWITCH, BRUSH MOTOR (S2A)	747022	747021
X8	PUMP, WATER (M1)	748021	748020
X9	SOLENOID VALVE, WATER (Y1)	19737014	N/A
X10	OPERATOR HANDLE CABLE	741093	740697
X11	OPERATOR HANDLE CABLE	740366	740697
X13	BATTERY CHARGER (BC)- INTERNAL RELAY	740366	740697
X14	BATTERY CHARGER (BC)-INTERNAL RELAY	740366	740697
X15	SOLENOID (Y1) /HOUR METER CONNECTION (HM)	740366	741165
X16	SOLENOID (Y1) /HOUR METER CONNECTION (HM)	740366	741165
X17 (optional)	OPTIONAL HOUR METER (HM) WIRE-747656	740366	741165
X18 (optional)	OPTIONAL HOUR METER (HM) WIRE-747657	740366	741165
X19	BATTERY GAUGE (BDI)	Part of BDI	747033
X20	SPEED POT ASSEMBLY (R1)	741298	741302
X21	SWITCH, TRANSAXLE (S4)	747022	747021
X22	OPERATOR HANDLE CABLE: 747632-1	747029	747033
X23	I-DRIVE HARNESS: 747673	Part of A1	748037
X24	TRANSAXLE (M4)	748021	748020
X25	I-DRIVE (A1) TO VACUUM SWITCH (S3)	740366-1	741165
X26	I-DRIVE (A1) TO VACUUM SWITCH (S3)	741093	740698
X27	I-DRIVE (A1) TO VACUUM RELAY-CONTACT	741093	741165
X28 (optional)	SWITCH, TOGGLE WATER PUMP (S8)	747022	747021
X29 (optional)	PUMP, OFF AISLE WAND (M1)	748021	748020

# Minuteman International Made Simple Commercial Limited Warranty



REVISION F  
EFFECTIVE 6/1/2009

Minuteman International, Inc. warrants to the original purchaser/user that the product is free from defects in workmanship and materials under normal use. Minuteman will, at its option, repair or replace without charge, parts that fail under normal use and service when operated and maintained in accordance with the applicable operation and instruction manuals. All warranty claims must be submitted through and approved by factory authorized repair stations.

This warranty does not apply to normal wear, or to items whose life is dependent on their use and care, such as belts, cords, switches, hoses, rubber parts, electrical motor components or adjustments. Parts manufactured by Minuteman are covered by and subject to the warranties and/or guarantees of their manufacturers. Please contact Minuteman for procedures in warranty claims against these manufacturers.

Special warning to purchaser — Use of replacement filters and/or prefilters not manufactured by Minuteman or its designated licensees, will void all warranties expressed or implied. A potential health hazard exists without original equipment replacement.

All warranted items become the sole property of Minuteman or its original manufacturer, whichever the case may be.

Minuteman disclaims any implied warranty, including the warranty of merchantability and the warranty of fitness for a particular purpose. Minuteman assumes no responsibility for any special, incidental or consequential damages.

This limited warranty is applicable only in the U.S.A. and Canada, and is extended only to the original user/purchaser of this product. Customers outside the U.S.A. and Canada should contact their local distributor for export warranty policies. Minuteman is not responsible for costs or repairs performed by persons other than those specifically authorized by Minuteman. This warranty does not apply to damage from transportation, alterations by unauthorized persons, misuse or abuse of the equipment, use of non-compatible chemicals, or damage to property, or loss of income due to malfunctions of the product.

If a difficulty develops with this machine, you should contact the dealer from whom it was purchased.

This warranty gives you specific legal rights, and you may have other rights which vary from state to state. Some states do not allow the exclusion or limitation of special, incidental or consequential damages, or limitations on how long an implied warranty lasts, so the above exclusions and limitations may not apply to you.

Cord Electric Group: Three years parts, two years labor, ninety days travel (Not to exceed two hours)

## Exceptions.....

Model	Parts	Labor	Poly	Travel
Port A Scrub	1yr	6months	10yrs	0
MPV 13	1yr	0	0	0
MPV 14 & 18	2yrs	1yr	0	0
V Series Upright Vacuums	1yr	1yr	0	0
Rapid Air Blower	1yr	1yr	10yrs	0
Explosion Proof Vacuum	1yr	1yr	0	0
X12, X12H & TRS 14	1yr	1yr	10yrs	0
E17 & E20 Electric Scrubbers	1yr	6month	10yrs	0
Pneumatic Vacuums	3yr	1yr	0	0

Description	Parts	Labor	Poly	Travel
Battery Operated Group	3yrs	2yrs	10	90 days
Sweepers	1yr	1yr	10	90 days
Internal Combustion Group	1yr	1yr	10	90 days

Not to exceed two hours

**Exception: PAS 14B**      **1yr**      **1yr**      **10yr**      **0**

## Battery Chargers:

Replacement Parts:

Batteries:

Polyethylene Plastic Tanks:

**One year replacement**

Ninety days

0-3 months replacement, 4-12 months pro-rate

Tanks have 10yr warranty, no additional labor