



Electronic Service Manuals

This electronic document is provided as a service to our customers. We do not create the contents of the information contained in this document. Should you have detailed questions pertaining to the information contained in this document, you may contact Michco, or the manufacturer which provided the original information in this electronic deliverable. Michco's only part in this electronic deliverable was the electronic assembly process. By providing this manual on line we are not guaranteeing parts availability.

You may contact Michco through the following methods:

Phone (517) 484-9312 or (800) 331-3339

2011 N. High St. -- Lansing, Michigan -- 48906

Fax: (517) 484-9836

Email: CustServe@Michco.com

Web site: www.Michco.Com

Parts Web site: www.FloorMachineParts.Com

Order Parts on Line at:

www.FloorMachineParts.Com

Directly to Parts & Service:

By Email: **Shop@Michco.com**

By Fax: (517) 702-2041

By Voice: Use numbers above.

Serving the Cleaning Industry Since 1922

Notice: All copyrighted material remains property of original owners, all trademarks are property of respective owners. Manuals are subject to Manufacturer's reproduction limitations. Originals or reproductions were provided by manufacturers through a request. We make no warranty as to the correctness of information provided in this document and you assume all risk. By placing these manuals on line we are not declaring our corporation to be an manufacturer authorized dealer or provider, please check our web site for authorized manufacturers we represent.

200X Brush Drive Floor Scrubber Battery

Model: MC20000QP, CE

OPERATION

SERVICE

PARTS

CARE

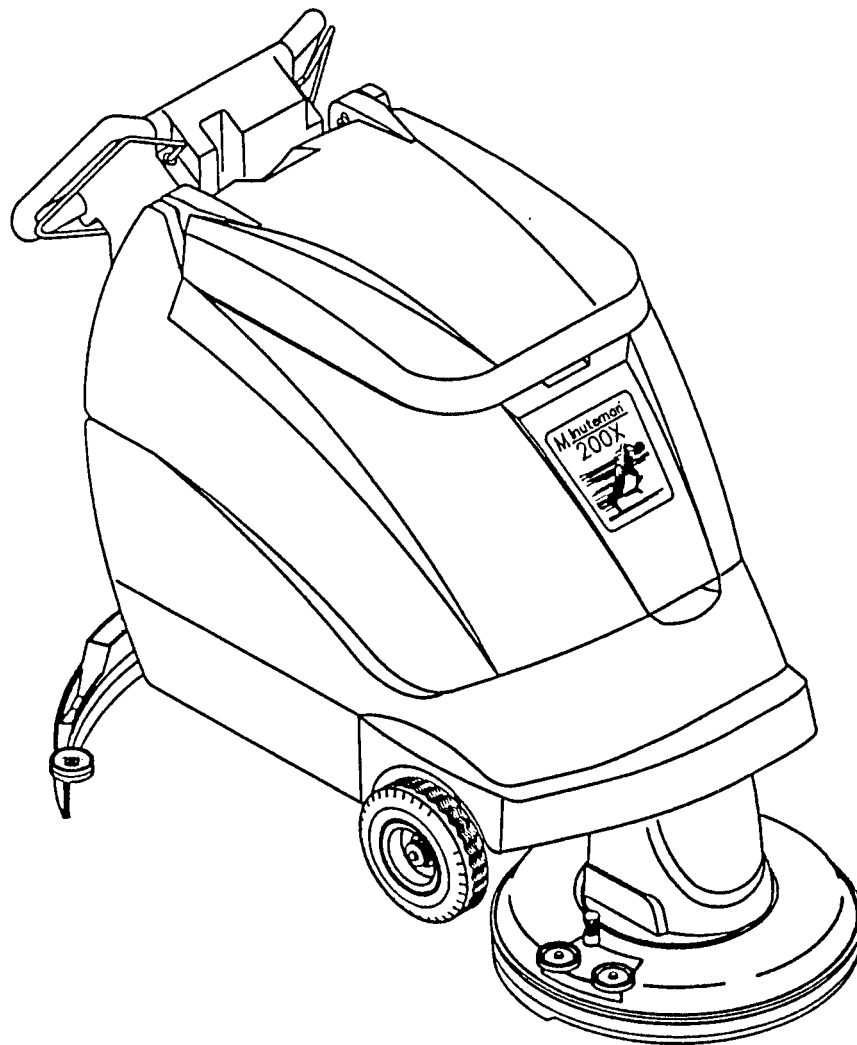

Revised 9/03

Minuteman[®]

EC Declaration of Conformity

according to Directives 72/23, 89/392, and 89/336

We, Minuteman International Incorporated, of 111 South Rohlwing Road Addison Illinois 60101 USA, declare under our sole responsibility that the product MC20004CE Commercial Automatic Floor Scrubber to which this declaration relates corresponds to the relevant requirements of the EC Directives 72/23, 89/392 and 89/336. The following standards were used to determine compliance with the Directives: EN 292, EN 294, EN 811, EN 55014, EN 55104 and IEC 335-1-72.

SOUND		VIBRATION						
81 dB Operator	77dB At 3m	4.8 m/s² At Operators Handle						
<p>Tests were conducted on 6/14/00 with calibrated sound and vibration equipment under the conditions noted below:</p> <table style="width: 100%; border: none;"> <tr> <td style="width: 33%;">General Condition: Indoors</td> <td style="width: 33%;">Wind: 0 km/hr</td> </tr> <tr> <td>Temperature: 23°C</td> <td>Humidity: 70%</td> </tr> <tr> <td>Barometric Pressure: 29.1</td> <td></td> </tr> </table>			General Condition: Indoors	Wind: 0 km/hr	Temperature: 23°C	Humidity: 70%	Barometric Pressure: 29.1	
General Condition: Indoors	Wind: 0 km/hr							
Temperature: 23°C	Humidity: 70%							
Barometric Pressure: 29.1								

Jeff Pollack

Jeff Pollack, Standards Engineer

6/15/00

Date

TABLE OF CONTENTS

	Page
Safety Instructions	1
Electrical Requirements	2
Control Panel Identification	3
Operating Instructions	4
Squeegee Adjustments	5
Brush Installation/Removal	6
Base Assembly	7 & 8
Tank Assembly	9 & 10
Upper Assembly	11
Console Assembly	12
Motor Lift Assembly	13
Scrubhead Assembly	14
Dashboard & Back Panel Assembly	15
Squeegee Lift & Mechanism Assembly	16
Squeegee Assembly Complete	17
Wiring Diagram	18
Wiring Diagram - CE	19

IMPORTANT SAFETY INSTRUCTIONS

CAUTION

Operators must read and understand this manual before operating or maintaining this equipment.

- Keep hands and feet clear of moving parts while machine is in operation.
- All switches must be in the “OFF” position when charging batteries.
- Electrical motors and components can cause an explosion when operated near explosive materials or vapors. Do not operate this machine near flammable materials such as solvents, thinners, fuels, grain dusts, etc.
- Make sure all switches are turned “OFF” and battery connections are removed before performing any maintenance procedures.
- Store or park this machine on a level surface only.
- These machines are designed for level floor operation only. DO NOT OPERATE on ramps or inclines.
- Battery acid can cause burns. When working on or around batteries, wear protective clothing and safety glasses. Remove metal jewelry. Do not lay tools or metal objects on top of batteries.
- This machine is not suitable for picking up hazardous dust.

Charging batteries generates explosive gases. DO NOT CHARGE BATTERIES WHEN OPEN FLAMES OR SPARKS ARE PRESENT. DO NOT SMOKE. Make sure the charger is turned off before disconnecting it from the batteries. Charge the batteries in a well-ventilated area.

Maintenance and repairs must be performed by authorized personnel.

SAVE THESE INSTRUCTIONS

ELECTRICAL REQUIREMENTS:

This piece of equipment operates on 24 Volt DC.

BATTERY REQUIREMENTS:

2 x 12V 105 Amp Hour 20 Hour Rate Deepcycle P/N 956712

BATTERY SERVICE AND INSTALLATION:

Warning: Battery acid can cause burns. When working on or around batteries, wear protective clothing and safety glasses. Remove metal jewelry. Do not lay tools or metal objects on top of batteries.

BATTERY INSTALLATION:

1. Raise tank assembly by gripping the front of the tank and lift the tank backward as shown in Fig. 1.
3. Install batteries as shown in Figure 2.

CHARGING OF BATTERIES:

Charging of batteries generates explosive gases. DO NOT CHARGE BATTERIES WHEN OPEN FLAMES OR SPARKS ARE PRESENT. DO NOT SMOKE. Make sure the charger is turned off before disconnecting it from the batteries. Charge the batteries in a well-ventilated area. Fluid levels should be checked before and after charging and maintained at the proper levels.

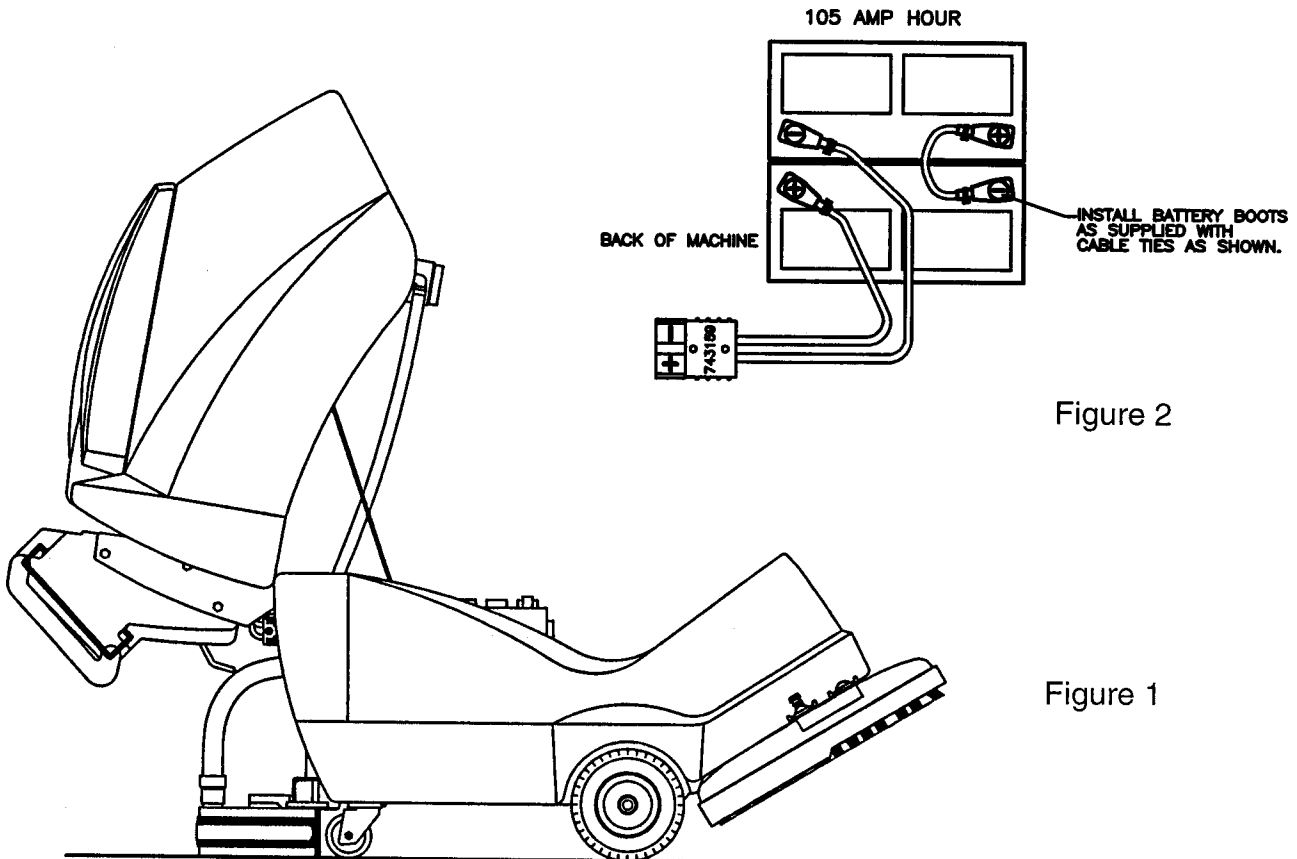
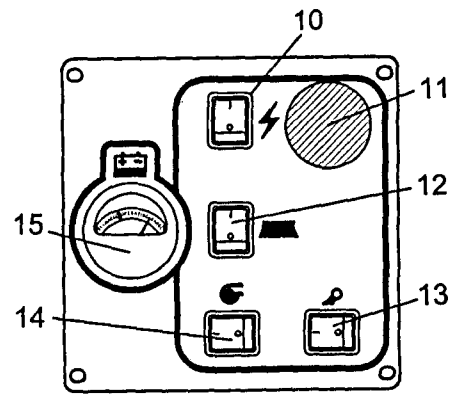
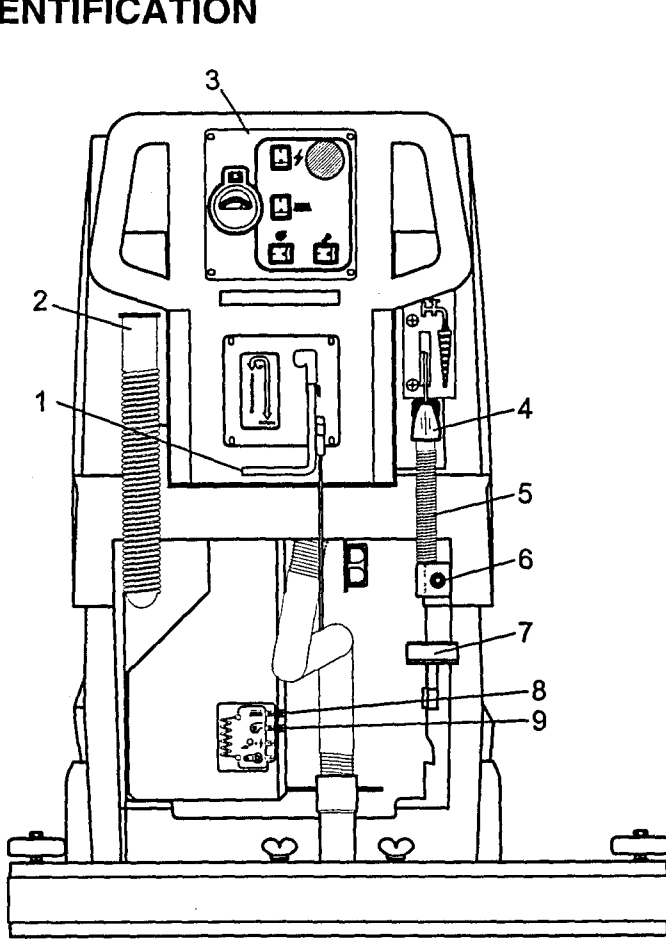

Figure 2

Figure 1

CONTROL PANEL IDENTIFICATION



1. Squeegee lift lever
2. Recovery dump hose
3. Dashboard control panel
4. Solution control lever
5. Solution dump hose
6. Quick disconnect aux. out (optional)
7. Food pedal
8. Circuit breaker - Brush
9. Circuit breaker - Vac
10. Main power
11. Emergency button
12. Brush switch
13. Pump switch
14. Vacuum switch
15. Battery gauge

AUTO SCRUBBER BRUSH DESCRIPTION

TYPE	DESCRIPTION	DURABILITY*	COLOR	COMPARISON TO PADS	RECOMMENDED USE
Bassine	Natural Fiber	Short	Dark Brown	Red	Light duty general cleaning, acid etching
Nylon	Nylon	Medium	Black	Tan/Red	General cleaning & scrubbing vinyl floors, ceramic tile & concrete floors
Dyna-Scrub	Nylon impregnated with 500 Grit Silicon Carbide Fine Bristle, Dense Fill	Long	Light Blue	Red	General scrubbing, vinyl tile, ceramic tile, epoxy floors, urethane finish, uneven concrete floors
Power-Scrub	Nylon impregnated with 120 Grit Silicon Carbide Fine Bristle, Dense Fill	Long	Rust	Red/Blue	Moderate aggressive scrubbing, tile floors, concrete floors
Poly-Grit	Nylon impregnated with 80 Grit Silicon Carbide Coarse Bristle	Long	Green	Brown/Black	Aggressive stripping and scrubbing, tile floors, unfinished concrete floors
Strata-Grit	Nylon impregnated with 46 Grit Silicon Carbide Coarse Bristle	Long	Dark Blue	Black	Heavy duty stripping/scrubbing unfinished concrete

• Durability is dependent on floor surface, chemicals used and proper care.

OPERATING INSTRUCTIONS

BEFORE STARING, FAMILIARIZE YOURSELF WITH THE MACHINE AND ITS CONTROLS (SEE “MACHINE OVERVIEW” & CONTROL PANEL DIAGRAMS)

1. Filling: Fill the solution tank with the desired amount of water and add liquid cleaning solution to the proper dilution ratio. DO NOT USE powdered cleaning chemicals. Powders are unlikely to dissolve thoroughly, resulting in clogging the in-line solution filter. This can reduce or stop water flow to the brush.
2. Close lid.
3. Turn on machine by lifting the red emergency disconnect button (11) so it is in the up position. Turn on main power switch (10).
4. Lower brush assembly.
 - To lower the brush, first push the pedal (7) slightly outward on the machine (unlock it), and then release it slowly.
 - To lift the brush, press the pedal (7) down until lift mechanism engages.
5. Turn on brush (12).
6. Adjust solution control feed lever (4).
7. Turn on vacuum switch (14).
8. Lower squeegee assembly by lowering handle (1).

After Use:

1. Turn off solution feed (4).
2. Switch off brush (12) and raise (7).
3. Raise squeegee assembly (1).
4. Turn off vacuum motor (14).

Solution and recovery tanks should be emptied after every use.

MAINTENANCE:

- | | |
|---------|--|
| Daily | <ol style="list-style-type: none">1. Clean float assembly & squeegee blades. Vac filter2. Recharge batteries (check battery acid levels before and after charging). |
| Monthly | <ol style="list-style-type: none">1. Check wear on squeegee blades.2. Grease front wheels.3. Grease pivot points on brush motor assembly. |

Every 500 hours check condition of carbon brushes on vacuum motor and brush drive motor.

SQUEEGEE ADJUSTMENTS

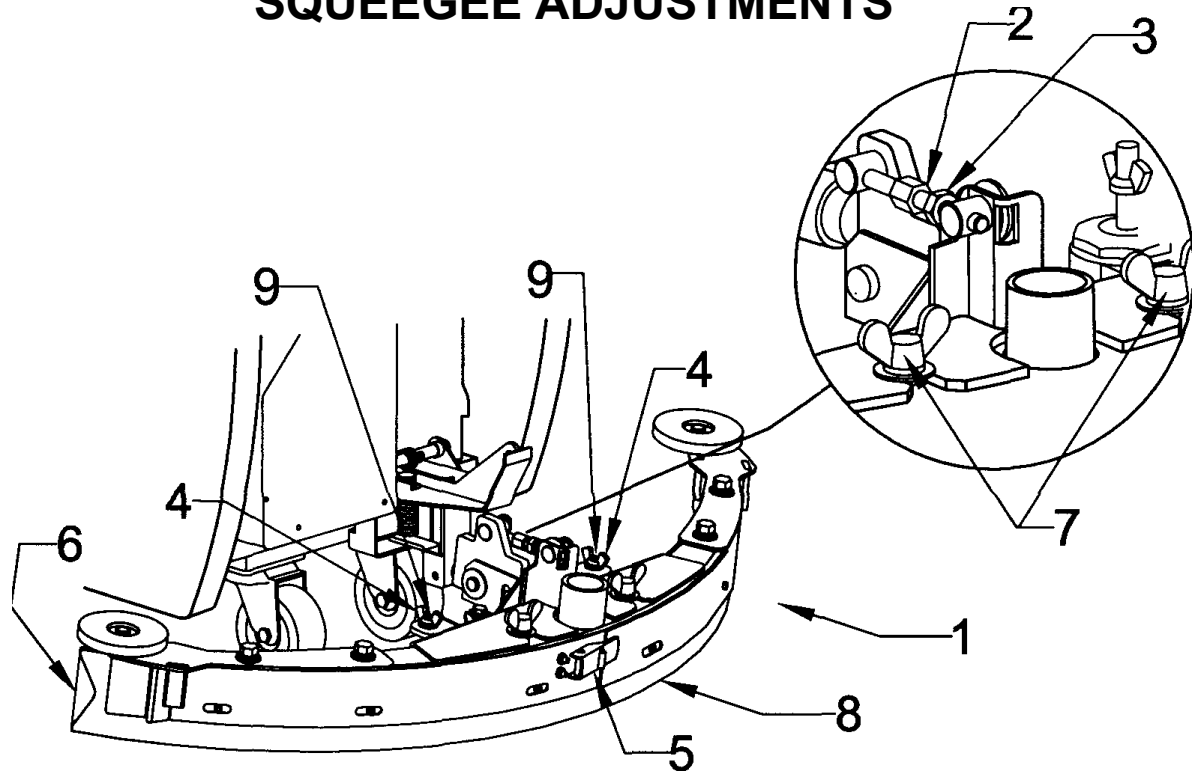

The squeegee set up is pre adjusted at the factory. Adjustments may be required to get optimum performance for different floors and conditions.

- 1 Ensure that the scrubber is on a relatively flat surface. Turn on the main power switch and lower the scrubhead assembly to the floor.
- 2 Lower the squeegee (item 1) to the floor. Move the machine one or two feet forward to check the rear squeegee blade (item 8) for uniform deflection to the floor.
- 3 If uneven deflection or lay is evident, minor adjustments may be necessary to avoid streaking and uneven wear on the blade.
- 4 To correct this, loosen the wing jam nut (item 4) in order to adjust the castor height. If the squeegee blade is deflecting too much, the castors need to be lowered to control the down pressure. Lower the castor by turning the exposed threaded stem (item 9) on the castor clockwise. Make the adjustment a few turns at a time. Repeat Step 2.
- 5 If the blades are not deflecting enough, raise the castor by turning the stem counter clockwise to adjust the castor height to allow more down pressure on the squeegee. Repeat Step 2.
- 6 Make sure that there is an even deflection on the entire length of the rear blade. Adjust the castors and retighten the wing jam nuts to lock the castor setting in place.
- 7 Pitch adjustment is necessary if the outer ends on the squeegee blade does not contact the floor and there is too much deflection in the middle area or if the outer ends are over deflected and there is no contact in the middle.
- 8 To adjust the pitch, lower the squeegee to the floor. Loosen the lock nut (item 3) in the turnbuckle assembly. Turning the turnbuckle (item 2) clockwise or counter clockwise controls the forward and backward pitch of the squeegee. Having the rear blades deflected uniformly along the entire length is the desired set up.
- 9 Repeat Step 2 until the desired set up is achieved.
- 10 In certain applications where a non-slotted front wiper blade (item 6) is needed, detach the squeegee assembly by loosening the wing bolts (item 7). Unlock the clamp on the front squeegee to release the straps and flip the blade over to the non-slotted side. Reattach straps and lock the clamp back in place.
- 11 You can also easily replace the rear blade by unlatching the latch (item 5) and removing the straps by sliding them off the assembly.

BRUSH INSTALLATION - REMOVAL

INSTALLATION

Brush Drive

1. Raise the scrubhead to the "UP" position by depressing the pedal (A) downward as shown on Fig. 1.
2. Center brush (D) under the scrubhead shroud while lining up the center hex drive hub and pressing the brush up until the brush engages on the drive hub.

REMOVAL

1. Raise the scrubhead to the "UP" position by depressing the pedal (A) downward as shown on Fig. 1.
2. Remove the brush (D) by stepping on the "BRUSH RELEASE PIN" on the top of the scrubhead shroud as shown on Fig. 1 below.

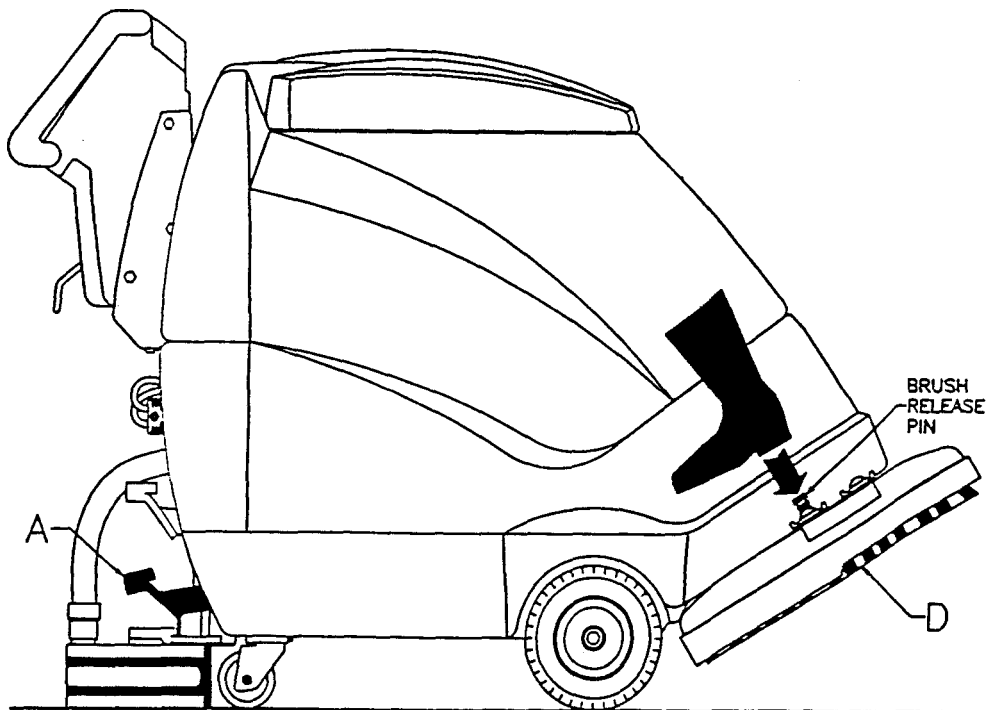
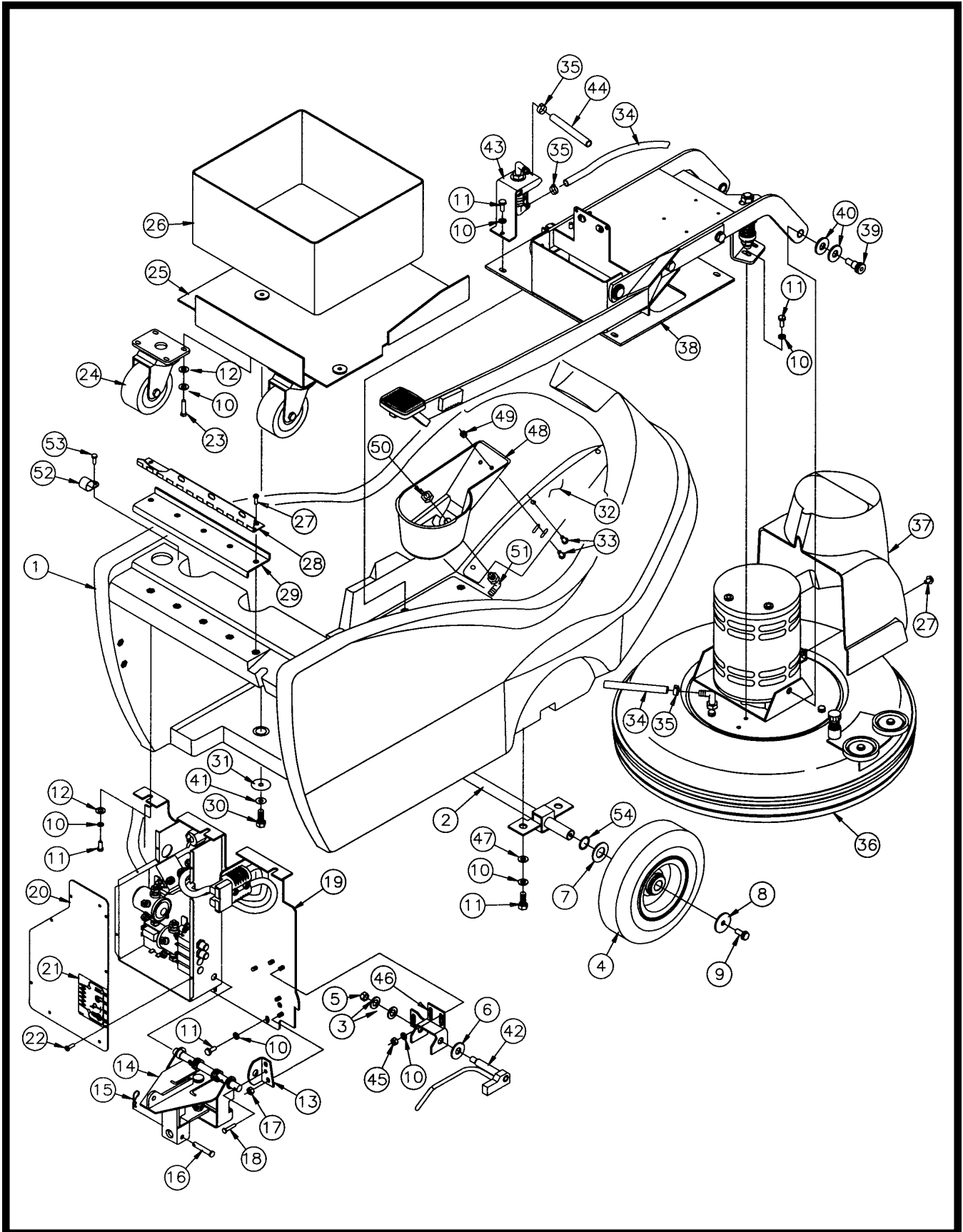

Figure 1

BASE ASSEMBLY



BASE ASSEMBLY

Parts List

Item	Part No.	Qty.	Description
1	200102	1	Base
2	200250	1	Axle Weldment
3	712310	2	WSR-Flat .52 x .87 x .06
4	762332	2	Wheel, 8 x 2 w/Bearing
5	711375	1	Nut-Nyloc 3/8-16
6	711578	1	WSR-Flat 1/2 Brass
7	712318	2	WSR-Flat 3/4 x 1.12 x .12
8	712759	2	WSR-Flat 5/16 x 1.37 x .06 SS
9	712042	2	BOLT-WSR HH 5/16-18 x .62
10	711544	30	WSR-Helical 1/4
11	711203	19	BLT-HH 1/4-20 x .62
12	711505	11	WSR-Flat 1/4
13	200158	1	Pin Bracket
14	200153	1	Squeegee Mechanism Assy.
15	711808	1	Cotter Pin
16	210415	1	Clevis Pin 5/16
17	711373	2	Nut-Nyloc 1/4-20
18	712564	1	Bolt-HH 1/4-20 x 1 SS
19	200265	1	Back Panel Assy. - BD
20	200154	1	Electrical Box Cover
21	715286	1	Decal, CB
22	711125	4	SCR-ST-B #10 x 1/2
23	713002	8	BLT-HH 1/4-20 x .75
24	200345	2	Caster, 3 1/2"
25	200125	1	Battery Tray Weldment
26	210048	1	Battery Liner
27	712565	5	SCR-MC 1/4-20 x .62 SS
28	200145	1	Hinge
29	200146	1	Hinge Plate
30	711228	4	Bolt-HH 5/16-18 x 3/4
31	711507	4	WSR-Flat .37 x 1.12 x .06
32	200233	1	Bottom Cover
33	712822	5	SCR-THMS 10-24 x 1/2
34	200235	1	Hose Nylobraid 17.50
35	450076	3	Crimp Clamp 185R SS
36	200255	1	Scrubhead Assy. BD
37	200186	1	Motor Cover
38	200280	1	Motor Lift Assy.
39	712099PLT	2	Shoulder Bolt 1/2 x .50
40	711510	4	WSR-Flat .50 x 1.38 x .10
41	711545	4	WSR-Helical 5/16
42	200130	1	Pawl Weldment
43	200260	1	Solution Valve Assy. - BD
44	200234	1	Solution Hose 51.00
45	711316	3	Nut-Hex 1/4-20
46	200129	1	Pawl Mounting Bracket
47	711575	4	WSR-Flat .312 x .75 x .06
48	200318MCH	1	Reservoir
49	712908	2	Nut-Wizz 10-24
50	260183	1	Nut-Nylon 1/4 NPT
51	833325	1	Barb 90° Elbow 3/8 x 1/4 NPT
52	82-54-A	1	Clamp
53	711106	1	SCR-ST-A 10 x .75 PL
54	711583	2	WSR-Wave .78 x 1.00 x .02

TANK ASSEMBLY

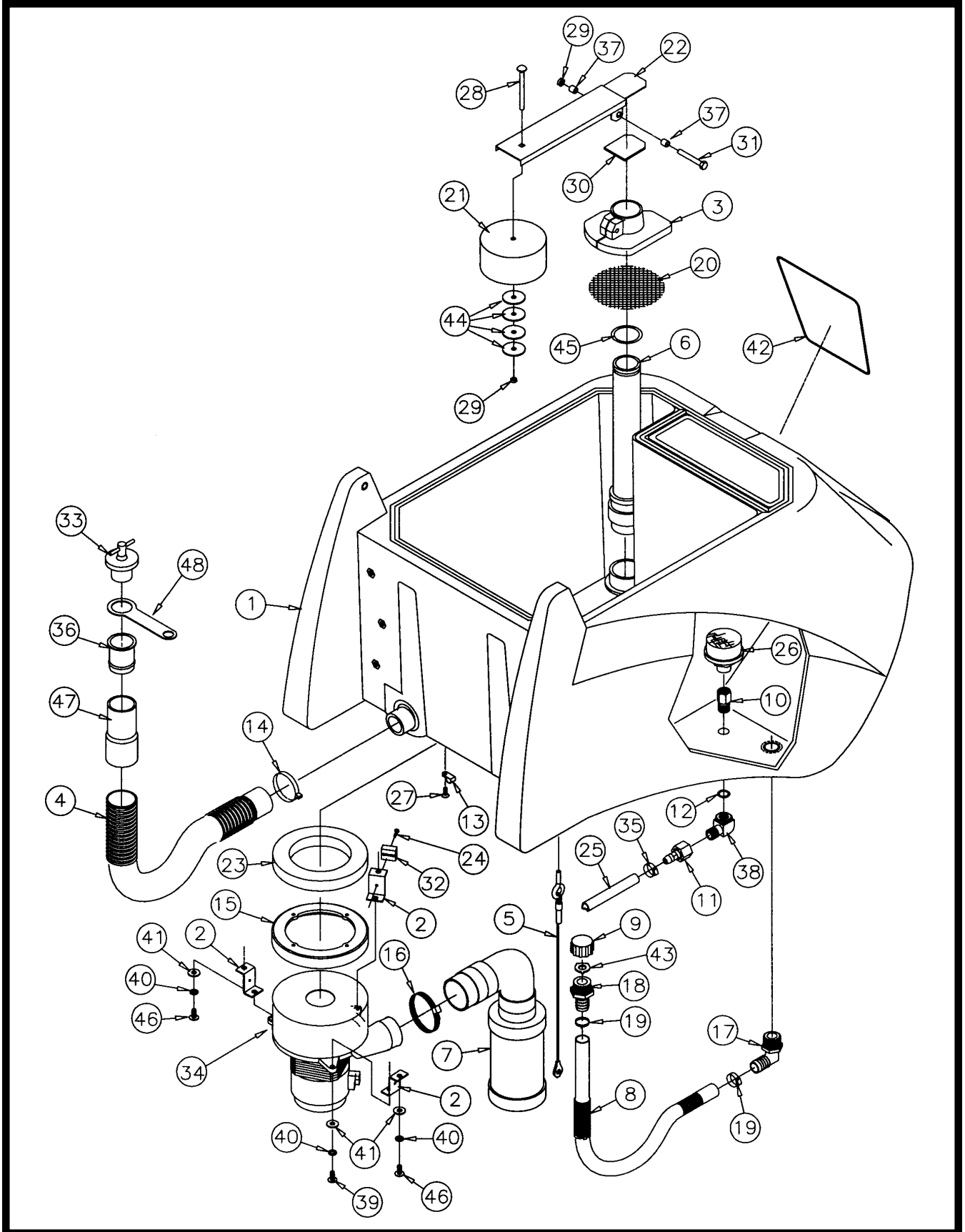

TANK ASSEMBLY Parts List

Item	Part No.	Qty.	Description
1	200101	1	Solution/Recovery Tank
2	200147	3	Bracket, Vac Motor
3	200173	1	Float, Housing
4	210122	1	Drain Hose, Wirelock
5	200232	1	Cable, Tank
6	200251	1	Stand Pipe Assembly
7	200258	1	Muffler Assembly
8	200270	1	Hose, 3/4 Solution Drain
9	200023	1	Garden Hose Cap
10	210409	1	Fitting, Brass 3/8 MPT
11	210410	1	Fitting, Brass 3/8 FPT
12	210414	1	"O" Ring 2-113
13	250038	3	Clamp, Plastic 5/16 3305
14	260203	1	Hose Clamp 102120 Murray
15	290017	1	Gasket, Molded, Vac Motor
16	760859	1	Clamp-Hose
17	383321	1	Elbow 3/4 MPT 3/4 Barb PP
18	200022	1	3/4" MGHT x Hose Barb
19	829129	2	Clamp, Crimp 3/4 Hose
20	430050	1	Filter Screen 4 x 4
21	260155	1	Foam Float
22	200320	1	Float Valve Weldment
23	460019	1	Gasket
24	710207	1	SCR-MC 6-32 x .87 ST PL
25	200234	1	Solution Hose
26	130118	1	Solution Strainer
27	712540	3	SCR-MC #10-24 x .375 SS
28	712574	1	CR Bolt SS 1/4-20 x 3"
29	712667	2	Nut-Hex 1/4-20 SS Nyloc
30	200321	1	Gasket, Shut-Off
31	712568	1	SCR-MC 1/4-20 x 2.25 SS
32	832996	1	Terminal Block 2-Pole VDE
33	833316	1	Drain Plug
34	740225	1	Vac Motor 6515-13 24V
35	760245	2	Hose Clamp 62P24
36	760343	1	Tube Hose 24/32B
37	762384	2	Bushing .277 x .375 x .37 SS
38	830062	1	Fitting Brass 90 3/8 MPT
39	710180	3	SCR-MC 1/4-20 x .75
40	711544	6	Lockwasher - Helical 1/4
41	711505	6	Washer 1/4
42	715285	1	Decal, 200X
43	200024	1	Black Vinyl Washer
44	712759	4	WSR-Flat .31 x 1.37 x .06 SS
45	310008	1	O-Ring
46	712565	3	SCR-MC 1/4-20 x .625 SS
47	805613	1	Hose Cuff, Grey Vinyl
48	320269	1	Strap, Drain Plug Retaining

UPPER ASSEMBLY

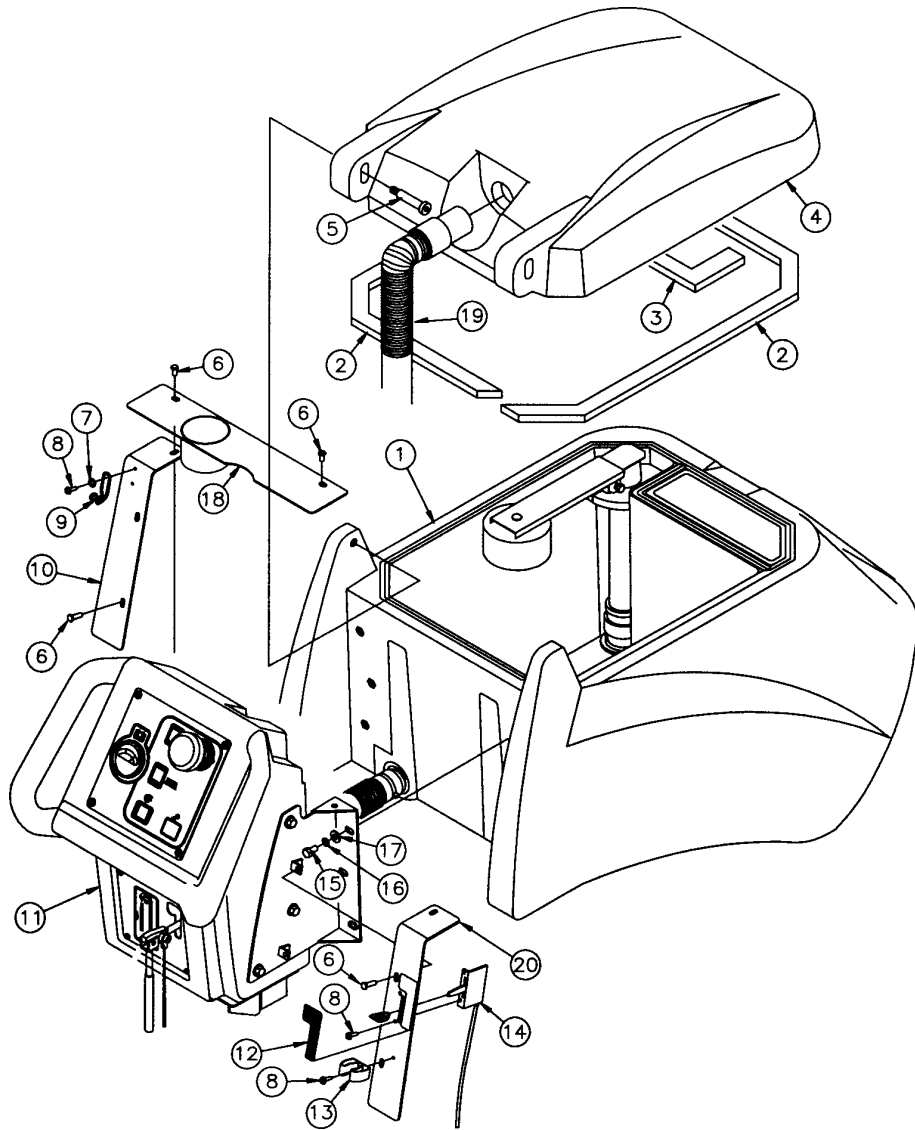

Parts List

Item	Part No.	Qty.	Description
1	200160	1	Tank Assembly
2	200178	2	Gasket, Lid
3	200136	1	Gasket, Solution Lid
4	200103	1	Tank Lid
5	712120	2	Shoulder Bolt 1/2 x 2
6	710178	6	SCR-MC 1/4-20 x 1/2
7	711503	2	WSR-Flat #10
8	711125	5	SCR-ST-B #10 x 1/2
9	760286	1	Wire Formed Hook
10	200176	1	Dump Hose Bracket
11	200170	1	Console Assy. - Brush Drive
12	715284	1	Decal, Solution Control
13	383367	1	Spring Clip
14	430053	1	Solution Control Cable
15	711228	6	Bolt-HH 5/16-18 x 3/4
16	711545	6	WSR-Helical 5/16
17	711575	6	WSR-Flat 5/16
18	200032	1	Console Back Cover Weldment
19	450054	1	Vacuum Recovery Hose
20	200152	1	Solution Control Bracket

CONSOLE ASSEMBLY

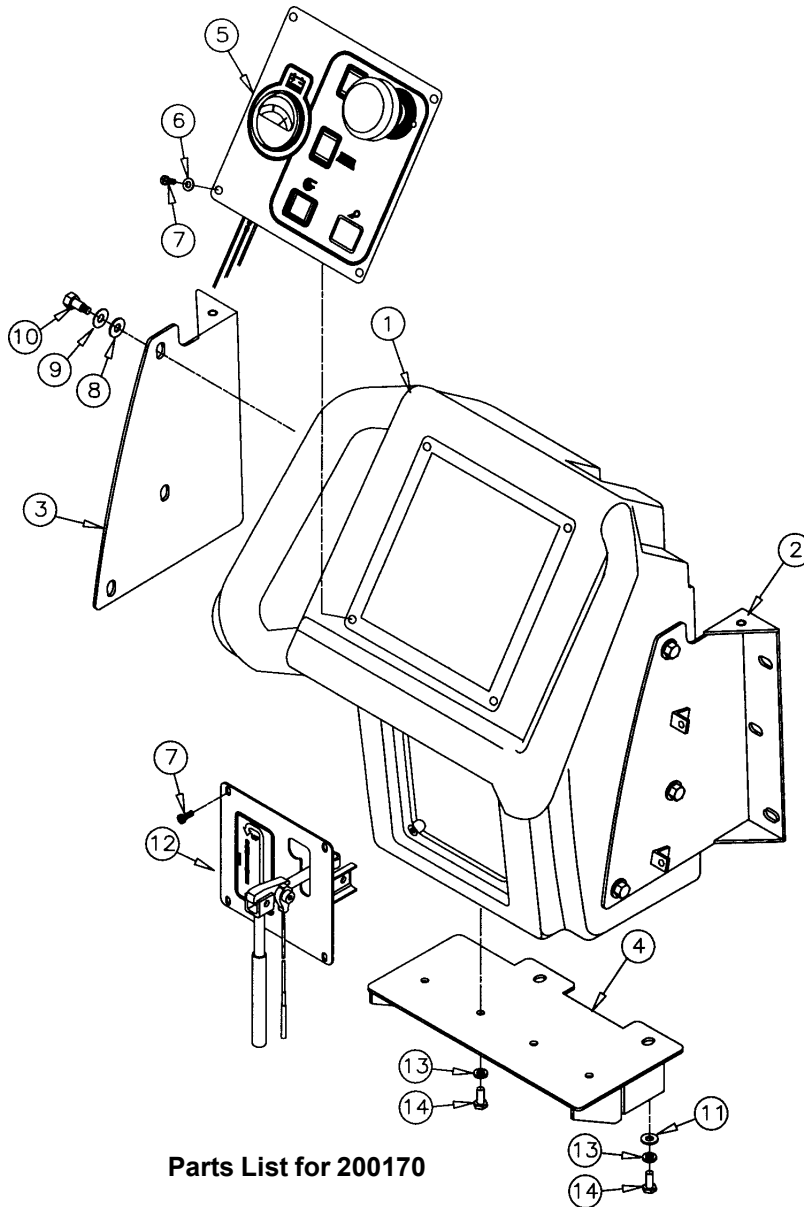

Parts List for 200170

Item	Part No.	Qty.	Description
1	200104	1	Console
2	200134	1	Console Bracket Right
3	200135	1	Console Bracket Left
4	200151	1	Hinge Bracket Weldment
5	200299	1	Dashboard ASM BD
6	712320	4	WSR-Nylon .22 x .45 x .04
7	712540	8	SCR-MC #10-24 x .37 SS
8	711575	6	WSR-Flat .31 x .75 x .06
9	711545	6	WSR-Helical 5/16
10	711228	6	Bolt-HH 5/16-18 x .75
11	711505	2	WSR-Flat 1/4
12	200240	1	Squeegee Lift Assy.
13	711544	6	WSR-Helical 1/4
14	711203	6	Bolt-HH 1/4-20 x .62

MOTOR LIFT ASSEMBLY

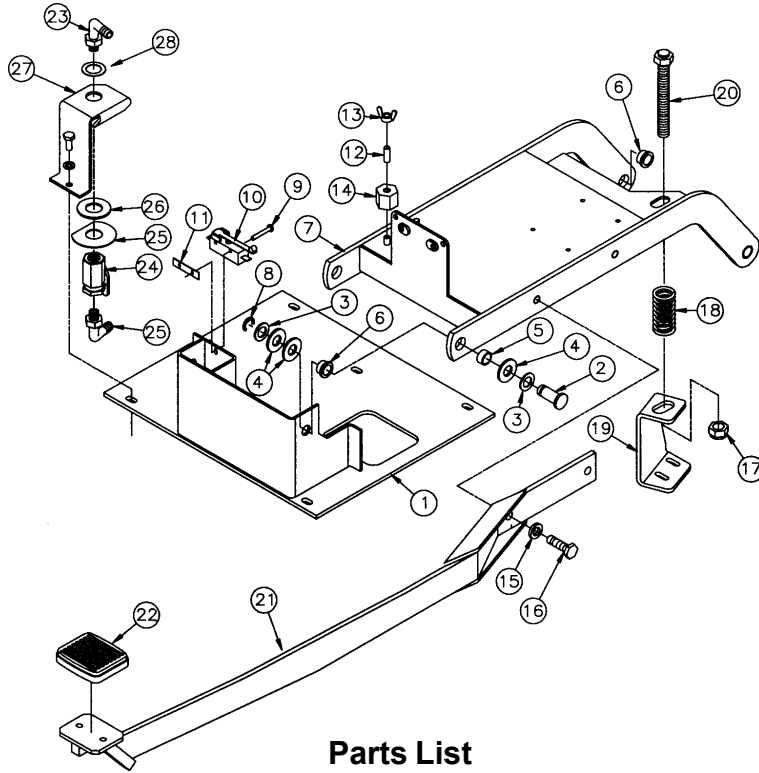

Parts List

Item	Part No.	Qty.	Description
1	200120	1	Base Plate Weldment
2	260036	2	Pin
3	712310	4	WSR-Flat .52 x .88 x .06
4	711527	6	WSR-Flat 5/8 x 1.12 x .12
5	762340	2	Oilite Bushing 1/2
6	260041	4	Oilite Flanged Bushing 1/2
7	200115	1	Lift Arm Weldment
8	711713	2	E-Ring 1/2
9	710207	2	SCR-MC 6-32 x .87
10	740128	1	Microswitch
11	711430	1	Tinnerman Clip
12	833638	2	Brass Stud
13	711368	2	Wing Nut
14	740132	2	Insulator Glastic
15	711546	2	WSR-Helical 3/8
16	713041	2	Bolt-HH 3/8-16 x 3/4
17	711376	1	Nut-Nyloc 1/2-13
18	260137	1	Compression Spring
19	200110	1	Spring Bracket
20	200149	1	Adjustment Rod
21	200116	1	Pedal Arm Weldment
22	210142	1	Pedal Pad
23	450040	2	Elbow 3/8 Barb x 3/8 MPT
24	809413MCH	1	Solution Valve Machined
25	829463	1	WSR-Flat SS
26	828975	1	WSR-Neoprene .75 x 1.5 x .09
27	200259	1	Valve Bracket
28	711513	1	WSR-Flat .689 x 1.06 x .029 SS

SCRUBHEAD ASSEMBLY

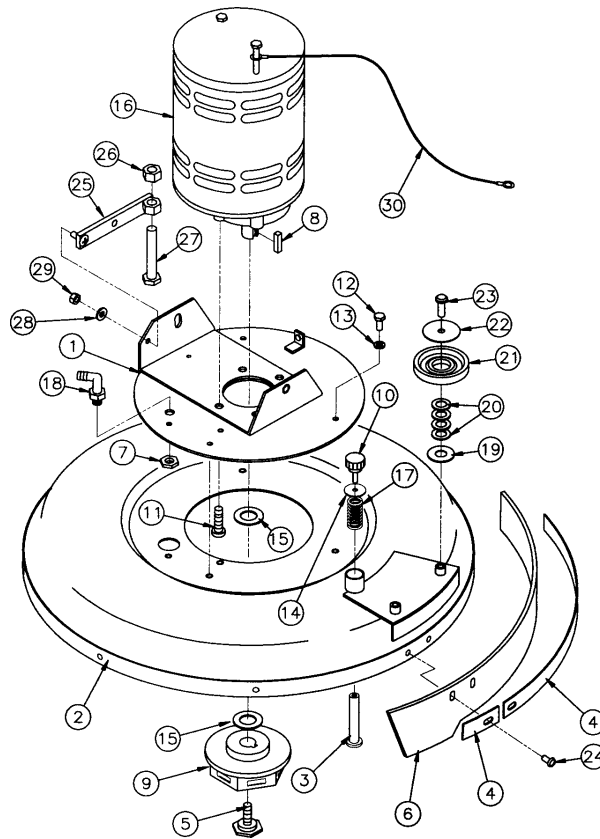

Parts List

Item	Part No.	Qty.	Description
1	200109	1	Motor Platform Weldment - BD
2	200187	1	Brush Shroud Weldment
3	200194	1	Pin, Brush Release
4	200294	2	Shroud Strap
5	210066	1	Retainer Bolt
6	200293	1	Shroud Skirt
7	260183	1	Nut 1/4 NPT Nylon
8	833621	1	Key, 1/4 x 1/4 x 1.00
9	430035	1	Drive Hub
10	500033	1	Locking Screw
11	710986	4	SCR-SC 3/8-16 x 1.00
12	711203	3	SCR-MC 1/4-20 x .62
13	711544	3	WSR-Helical 1/4
14	711519	1	WSR-Flat .25 x 1.01 x .06
15	711517	2	WSR-Flat .77 x 1.37 x .03
16	740209	1	Gear Motor 24V
17	833102	1	Spring
18	833325	1	Hose Barb 90° Nylon
19	711578	2	WSR-Flat 1/2 Brass
20	712310	8	WSR-Flat .52 x .87 x .06
21	430085	2	Bumper Wheel
22	712759	2	WSR-Flat .31 x 1.37 x .06 SS
23	710975	2	SCR-SC 5/16-18 x .87
24	712560	8	SCR-MC 1/4-20 x .50 Nyloc
25	200029	1	Pitch Adj. Bar Weldment
26	711334	1	Nut-Hex 1/2-13
27	710754	1	Bolt-HH 1/2-13 x 2 3/4
28	711505	1	WSR-Flat 1/4
29	711373	1	Nut-Nyloc 1/4-20
30	743425	1	Ground Wire

DASHBOARD

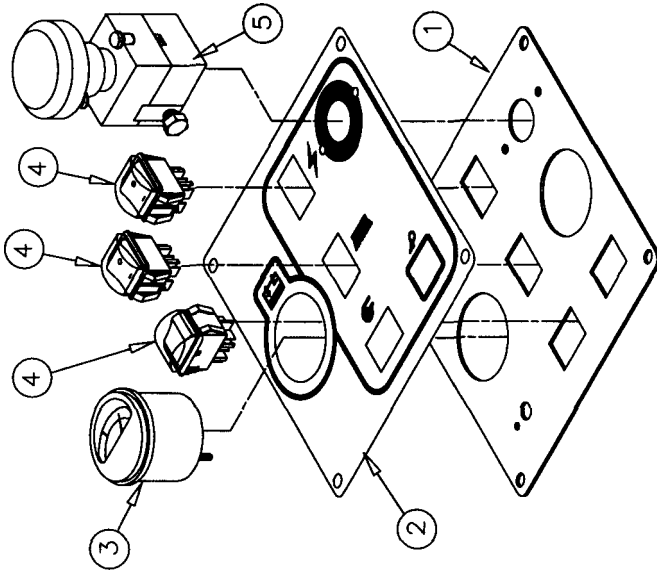

Parts List for 200299

Item	Part No.	Qty.	Description
1	200179	1	Dashboard Plate
2	715283	1	Decal 200 Dashboard
3	740216	1	Battery Gauge
4	740711CE	3	Switch Dreefs w/Splashguard
5	742202	1	Disconnect Switch 125A

BACK PANEL

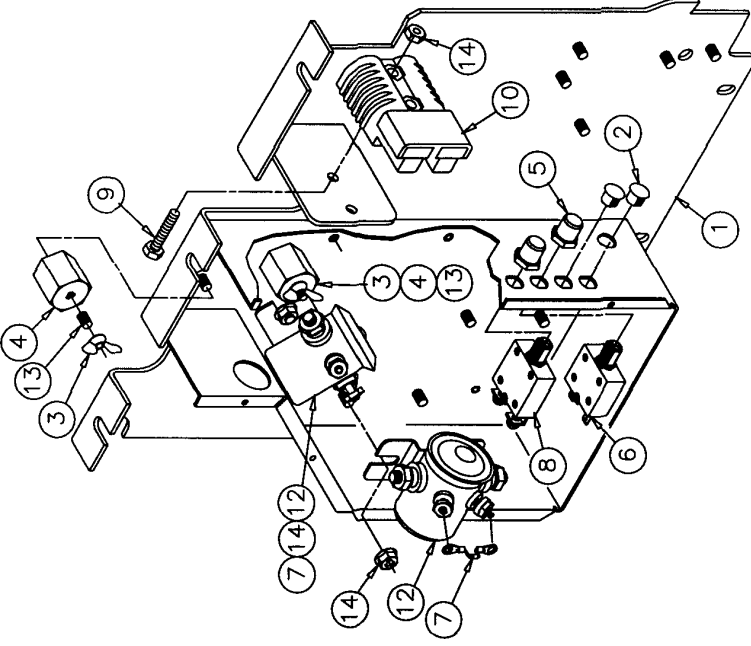

Parts List for 200265

Item	Part No.	Qty.	Description
1	200124	1	Backpanel Weldment
2	742749	2	Circuit Breaker Plug
3	711368	2	Wing Nut, 1/4-20
4	740132	2	Insulator (Glastic)
5	742748	2	Boot, Circuit Breaker
6	740247	1	Circuit Breaker 30
7	742000	2	Diode Assembly
8	740549	1	Circuit Breaker 50
9	711210	2	SCR-HH 1/4-20 x 1 1/4
10	740159	1	CB175 Red Housing Only
11	743260	1	Wire Harness, 200X BD
12	788147	2	Solenoid 24VDC
13	833638	2	Brass Stud
14	711425	6	Whiz-Nut 1/4-20

SQUEEGEE LIFT

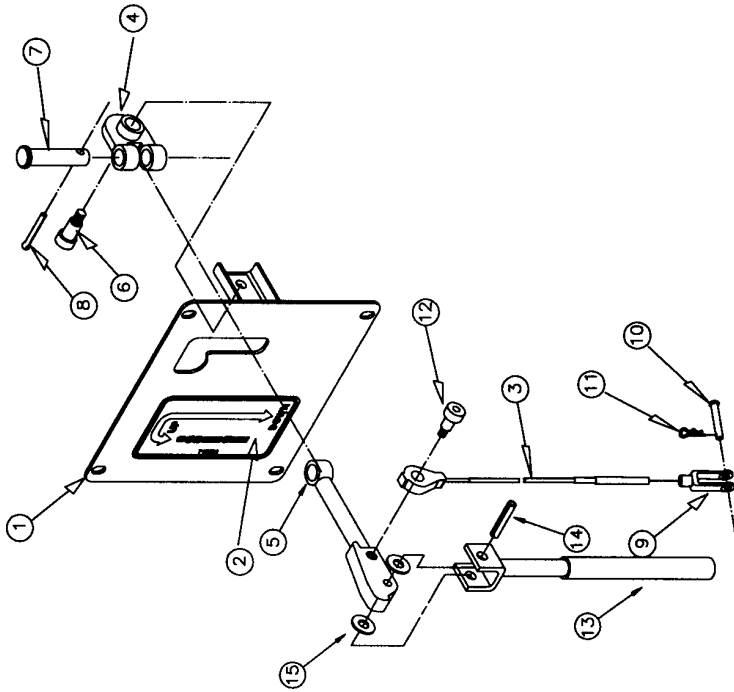

Parts List for 200240

Item	Part No.	Qty.	Description
1	200239	1	Panel Cover Weldment
2	715603	1	Decal Squeegie Lift
3	200241	1	Squeegie Lift Cable
4	200261	1	Inner Arm Weldment
5	200017	1	Arm Squeegie Lift Weldment
6	712081	1	Bolt, Shoulder 5/16 x .75
7	831965	1	Clevis Pin 3/8
8	809311	1	Cotter Pin 7/64 x 1"
9	881009	1	Yoke
10	881002	1	Clevis Pin 5/16
11	711808	1	Cotter Pin #13
12	712041	1	Bolt-Shoulder 5/16 x .44
13	200038	1	Handle Weldment
14	711642	1	3/16 x 1.00 Roll Pin
15	711504	2	WSR-Flat 1/4, SS

SQUEEGEE MECHANISM

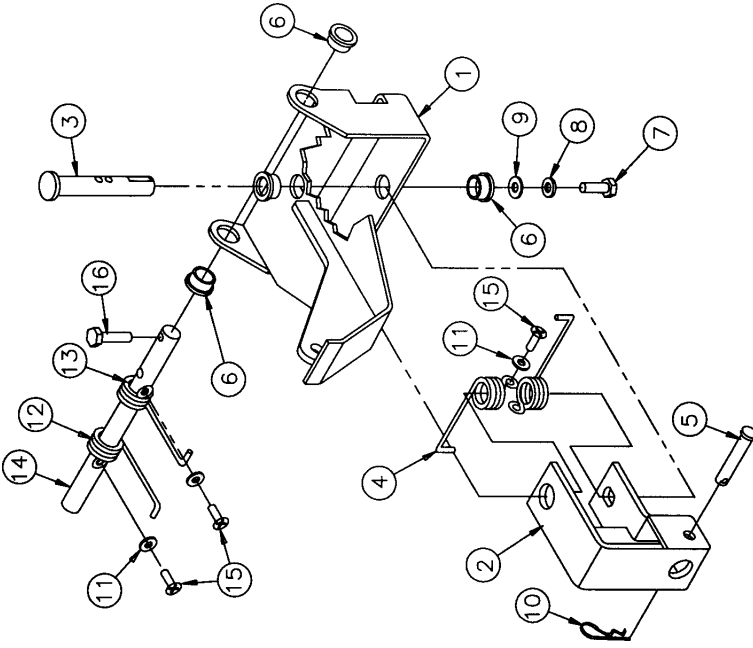

Parts List for 200153

Item	Part No.	Qty.	Description
1	200144	1	Spring Housing Weldment
2	200300	1	Yoke Weldment
3	210375	1	Swivel Pin
4	210391	2	Return Spring SS
5	210415	1	Clevis Pin .31 x 1.7 11-097
6	260041	4	Oilite Flange Bushing
7	710180	1	SCR-MC 1/4-20 x .75 ST PL
8	711544	1	WSR-Helical 1/4
9	711519	1	WSR-Flat .25 x 1.01 x .06
10	711808	1	Cotter Pin - Hair #13
11	712320	4	WSR-Nylon .22 x .45 x .04
12	900080	1	Spring, Torsion RH
13	900081	1	Spring, Torsion LH
14	200159	1	Pin
15	712536	4	SCR-MC 10-24 x .62 SS
16	712564	1	BLT-HH 1/4-20 x 1.00 SS

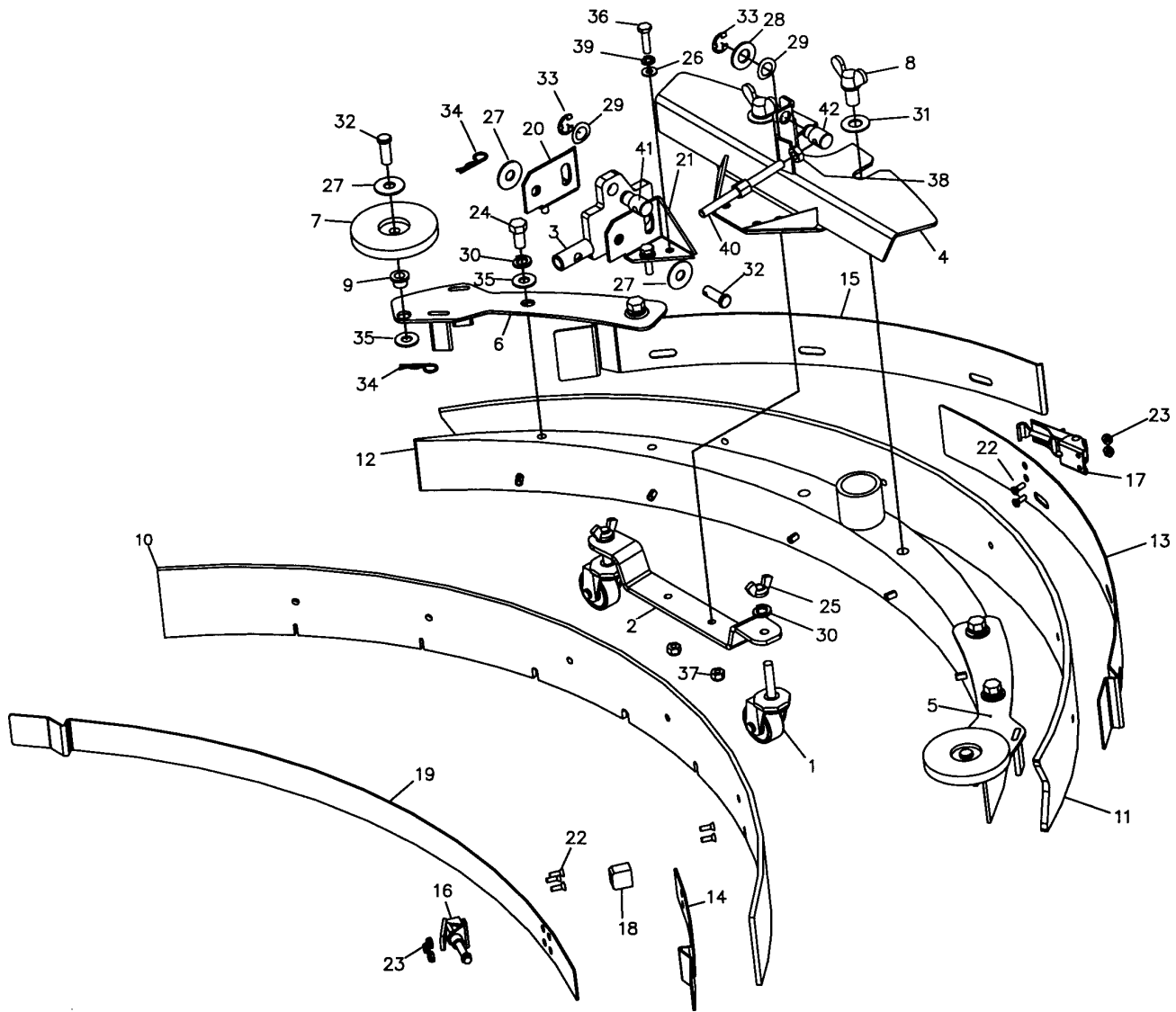

Parts List for 200348

Item	Part No.	Qty.	Description	Item	Part No.	Qty.	Description
1	200064	2	Caster Wheel 3/8"-16 x 1-5/8"	22	710530	7	SCR-MC 8-32 x .50 BR
2	200065	1	Castor Support Bracket	23	711026	5	Nut, Hex 8-32 Nyloc SS
3	200169	1	200X Sq Lift Weldmt New	24	711241	4	SCR-Hex 3/8-16 x .75" ZP
4	200342	1	Squeegee Brkt Weldmt, 200X	25	711367	2	Nut-Wing 3/8-16 ST PL
5	200344	1	Top Plate Weldmt, 200X LH	26	711504	4	WSR-Flat 1/4 ID SS
6	200347	1	Top Plate Weldmt, 200X RH	27	711507	4	WSR-Flat .37 x 1.12 x .06
7	210153	2	Roller Wheel	28	711509	1	WSR-Flat 1/2 (.54 x 1.08 x .087)
8	220249	2	Wing Bolt 1/2-13 x .75"	29	711524	2	WSR-Wave .52 x .87 x .01
9	260066	2	Oilite Bushing	30	711546	6	WSR-Helical 3/8
10	260242	1	Front Squeegee Blade 260	31	711592	2	WSR-Nylon .50 x 1.06 x .06
11	260243	1	Rear Squeegee Blade 260	32	711668	3	Cleavis Pin, 3/8 x 1 11-141
12	260248	1	260 Sq. Casting w/Roll Pin	33	711713	2	Retaining Ring - "E" Type Ext .500
13	260339	1	Strap - Rear Latch 260	34	711808	3	Cotter Pin - Hair #13
14	260344	1	Strap - Front Stop 260	35	712301	6	WSR-Flat .87 x .37 x .06
15	260346	1	Strap - Rear Catch 260	36	712564	4	Bolt-HH 1/4-20 x 1.00 SS
16	281074	1	Squeegee Toggle Clamp, 2800	37	712667	2	Nut, Hex 1/4-20 Nyloc SS
17	281075	1	Squeegee Latch, 2800	38	712680	1	Nut-Hex 5/16-18 SS
18	281740	1	Stop Bar	39	712758	4	WSR-Helical 1/4 SS
19	320308	1	Strap-Front Clamp 320	40	750689	1	Adjustment Stud
20	383424	1	Mounting Bracket-Right	41	762022PLT	1	Nut, Adjusting (LH)
21	383425	1	Mounting Bracket-Left	42	762257PLT	1	Nut, Adjusting (RH)

LIMITED WARRANTY

Minuteman International, Inc. warrants to the original purchaser/user that this product is free from defects in workmanship and materials under normal use and service for a period of three years from date of purchase. In addition, Minuteman International, Inc. will, at its option, honor labor warranty claims for the first 12 months from date of sale, provided such claims are submitted through and approved by factory authorized repair stations. Minuteman International, Inc. will, at its option, repair or replace without charge, except for transportation costs, parts that fail under normal use and service when operated and maintained in accordance with the applicable operation and instruction manuals.

This warranty does not apply to normal wear, or to items whose life is dependent on their use and care, such as belts, cords, switches, hoses, rubber parts, electrical motor components or adjustments. Parts not manufactured by Minuteman International, Inc. such as engines, batteries, battery chargers, hydraulic pumps, and tires are covered by and subject to the warranties and/or guarantees of their manufacturers. Please contact Minuteman International, Inc. for procedures in warranty claims against these manufacturers.

Special warning to purchaser — Use of replacement filters and/or prefilters not manufactured by Minuteman International, Inc. or its designated licensees, will void all warranties expressed or implied.

A potential health hazard exists without exact original equipment replacement.

All warranted items become the sole property of Minuteman International, Inc. or its original manufacturer, whichever the case may be.

Minuteman International, Inc. disclaims any implied warranty, including the warranty of merchantability and the warranty of fitness for a particular purpose. Minuteman International, Inc. assumes no responsibility for any special, incidental or consequential damages.

This limited warranty is applicable only in the U.S.A. and Canada, and is extended only to the original user/purchaser of this product. Customers outside the U.S.A. and Canada should contact their local distributor for export warranty policies. Minuteman International, Inc. is not responsible for costs or repairs performed by persons other than those specifically authorized by Minuteman International, Inc. This warranty does not apply to damage from transportation, alterations by unauthorized persons, misuse or abuse of the equipment, use of non-compatible chemicals, or damage to property, or loss of income due to malfunctions of the product.

If a difficulty develops with this machine, you should contact the dealer from whom it was purchased.

This warranty gives you specific legal rights, and you may have other rights which vary from state to state. Some states do not allow the exclusion or limitation of special, incidental or consequential damages, or limitations on how long an implied warranty lasts, so the above exclusions and limitations may not apply to you.

Minuteman[®]

World Headquarters
Minuteman International, Inc.
111 South Rohlwing Road
Addison, Illinois 60101

(630) 627-6900
FAX (630) 627-1130

Minuteman Canada, Inc.
2210 Drew Road
Mississauga, Ontario
L5S 1B1

(905) 673-3222
FAX (905) 673-5161

986763
Printed in U.S.A.