



Electronic Service Manuals

This electronic document is provided as a service to our customers. We do not create the contents of the information contained in this document. Should you have detailed questions pertaining to the information contained in this document, you may contact Michco, or the manufacturer which provided the original information in this electronic deliverable. Michco's only part in this electronic deliverable was the electronic assembly process.

You may contact Michco through the following methods:
Phone (517) 484-9312 or (800) 331-3339 MI, OH, IN only
2011 N. High St. -- Lansing, Michigan -- 48906
Fax: (517) 484-9836
Email: CustServ@Michco.com
Web site: www.Michco.Com
Parts Web site: www.FloorMachineParts.Com

Order Parts on Line at:
www.FloorMachineParts.Com

Directly to Parts & Service:
By Email: **Shop@Michco.com**
By Fax: (517) 702-2041
By Voice: Use numbers above.

Serving the Cleaning Industry Since 1922

Notice: All copyrighted material remains property of original owners, all trademarks are property of respective owners. Manuals are subject to Manufacturer's reproduction limitations. Originals or reproductions were provided by manufacturers through a request. We make no warranty as to the correctness of information provided in this document and you assume all risk.

**200 Floor
Scrubber
Electric**

Model: MC20115
MC20230
MC20230CE

■ OPERATION ■ SERVICE ■ PARTS ■ CARE

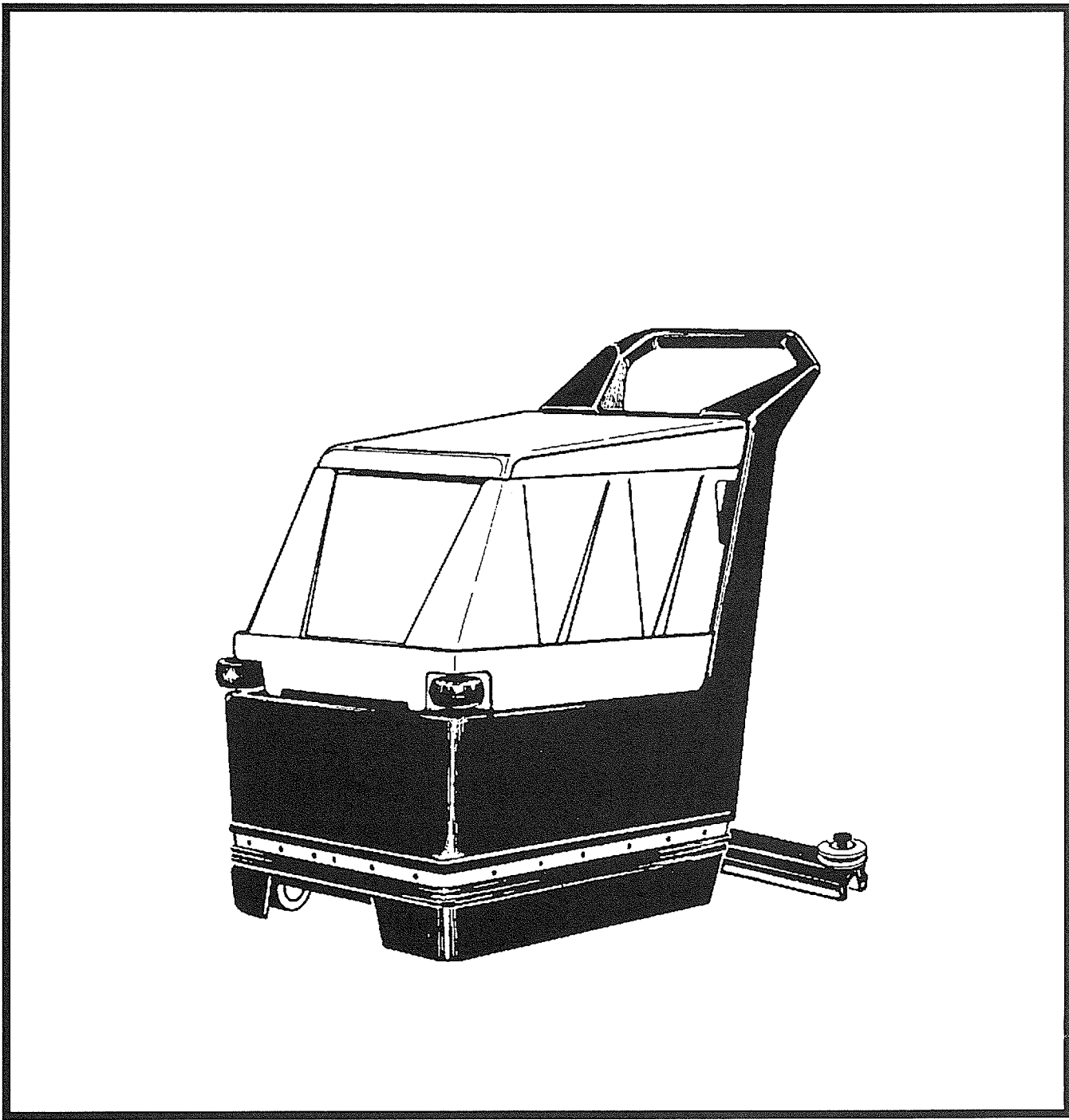

Revised 3/01

Minuteman[®]

EC Declaration of Conformity

according to Directives 72/23, 89/392, and 89/336

We, Minuteman International Incorporated, of 111 South Rohlwing Road Addison Illinois 60101 USA, declare under our sole responsibility that the product MC20230CE Commercial Automatic Floor Scrubber to which this declaration relates corresponds to the relevant requirements of the EC Directives 72/23, 89/392 and 89/336. The following standards were used to determine compliance with the Directives: EN 292, EN 294, EN 811, EN 55014, EN 55104 and IEC 335-1-72.

SOUND		VIBRATION						
83 dB Operator	80dB At 3m	2.5 m/s² At Operators Handle						
<p>Tests were conducted on 4/21/97 with calibrated sound and vibration equipment under the conditions noted below:</p> <table style="width: 100%; border: none;"> <tr> <td style="width: 33%;">General Condition: Indoors</td> <td style="width: 33%;">Wind: 0 km/hr</td> </tr> <tr> <td>Temperature: 23°C</td> <td>Humidity: 70%</td> </tr> <tr> <td>Barometric Pressure: 29.5</td> <td></td> </tr> </table>			General Condition: Indoors	Wind: 0 km/hr	Temperature: 23°C	Humidity: 70%	Barometric Pressure: 29.5	
General Condition: Indoors	Wind: 0 km/hr							
Temperature: 23°C	Humidity: 70%							
Barometric Pressure: 29.5								

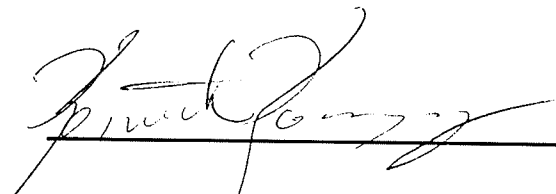

 Kenneth Kaczmarz, Standards Engineer

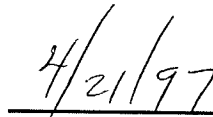

 Date

TABLE OF CONTENTS

	Page
Safety Instructions	1
Electrical Requirements	2
Control Panel Identification	3
Brush Installation Instructions	4
Operating Instructions/ Maintenance	5
Main Polyethelene Components	6 & 7
Solution/Recovery Tank	8 & 9
Vacuum Components	10 & 11
Brush Drive Assemblies	12 & 13
Back Panel	14 & 15
Squeegee Assembly	16 & 17
Wiring Diagram	18

FOR COMMERCIAL USE ONLY

IMPORTANT SAFETY INSTRUCTIONS

When using an electrical appliance, basic precautions should always be followed, including the following:

READ ALL INSTRUCTIONS BEFORE USING

WARNING - To reduce the risk of fire, electric shock, or injury:

- Do not leave appliance when plugged in. Unplug from outlet when not in use and before servicing, cleaning or maintaining.

WARNING

To reduce the risk of electric shock - Do not expose to rain. Store indoors.

- Do not allow to be used as a toy. Close attention is necessary when used by or near children.
- This machine shall be used only by instructed and authorized persons.
- Use only as described in this manual. Use only manufacturer's recommended attachments.
- Inspect cord regularly. Do not use with damaged cord or plug. If appliance is not working as it should, has been dropped, damaged, left outdoors, or dropped into water, return it to a service center. Use only cord specified by manufacturer.
- Do not pull or carry by cord, use cord as a handle, close a door on cord, or pull cord around sharp edges or corners. Do not run appliance over cord. Keep cord away from heated surfaces.
- Do not unplug by pulling on cord. To unplug, grasp the plug, not the cord.
- Do not handle plug or appliance with wet hands.
- Do not put any object into openings. Do not use with any opening blocked; keep free of dust, lint, hair, and anything that may reduce air flow.
- Keep hair, loose clothing, fingers, and all parts of body away from openings and moving parts.
- Do not pick up anything that is burning or smoking, such as cigarettes, matches, or hot ashes.
- Do not use without dustbag and/or filters in place.
- Turn off all controls before unplugging.
- Use extra care when cleaning on stairs.
- Do not use to pick up flammable or combustible liquids such as gasoline or use in areas they may be present.
- Connect to a properly grounded outlet only. See grounding instructions.
- This machine is not suitable for picking up hazardous dust.
- Close tank and lid before use.

SAVE THESE INSTRUCTIONS

INSPECTION

Carefully unpack and inspect your machine for shipping damage. Each unit is tested and thoroughly inspected before shipment and any damage is the responsibility of the delivering carrier who should be notified immediately.

WARNING

- Read Instruction Manual before operating this piece of equipment.
- To reduce the risk of fire, use only commercially available floor cleaners and waxes intended for machine application.
- To reduce the risk of electrical shock, do not expose to rain. Store indoors.
- Do not cross over supply cord, hazard exists when rotating brush passes over cord.
- Electrical motors and components can cause an explosion when operated near volatile materials and vapors. Do not use this machine near flammable materials such as solvents, thinners, fuels, grain dust, etc.

ELECTRICAL

(Model MC20115) This floor machine is designed to operate on a standard 15 amp, 120 volt, 60 hz, AC circuit. Voltages below 105 volt AC or above 125 volts AC could cause serious damage to the motor.

(Model MC20230) This machine is designed to operate on a standard 16 amp type L fused 230 volt, 50 hz, AC circuit. Voltages below 200 volts AC or above 250 volts AC could cause serious damage to the motor I.E.C. Class 1.

GROUNDING INSTRUCTIONS

- This floor finishing machine should be grounded while in use to protect the operator from electric shock. The machine is equipped with a three-prong grounding type attachment plug to fit the proper grounding type receptacle. The green (or green and yellow) conductor in the cord is the grounding wire. Never connect this wire to other than the grounding blade.
- Floor finishing machines rated less than 150 volts — If the machine is provided with an attachment plug as shown in Sketch A it is intended for use on a 120-volt (nominal) circuit. If a properly grounded receptacle as shown in Sketch A is not available, an adapter as shown in Sketch C is available and should be installed as shown in Sketch B if the outlet box that houses the receptacle is grounded. Be sure to fasten the grounding tab with the faceplate screw.

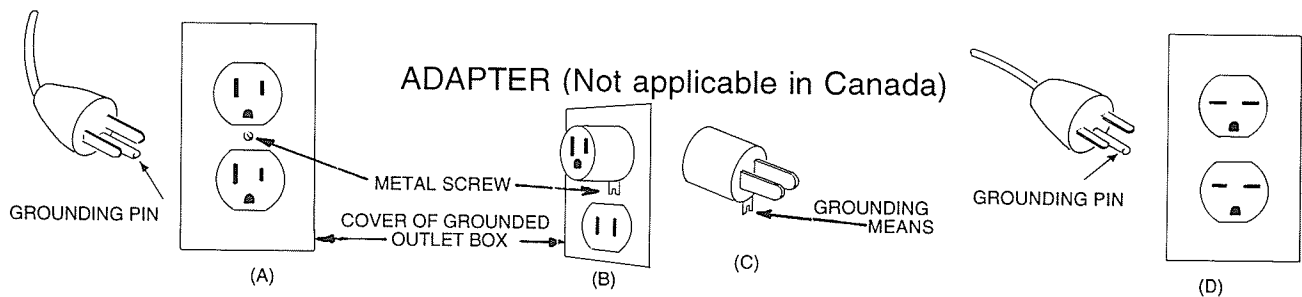

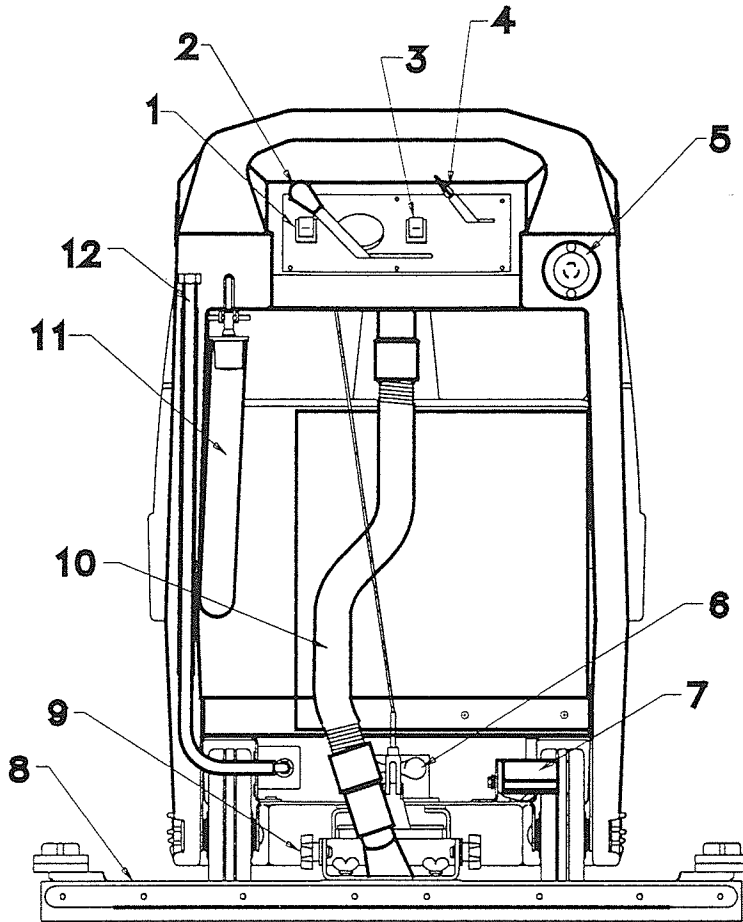

- | | |
|---------------------------|---------------------------------------|
| 1. Vacuum switch | 7. Foot pedal for lower/raising brush |
| 2. Squeegee lift lever | 8. Squeegee |
| 3. Brush switch | 9. Squeegee pitch control |
| 4. Solution control lever | 10. Recovery hose |
| 5. Power connection cable | 11. Recovery tank dump hose |
| 6. Power assist control | 12. Solution tank dump hose |

SQUEEGEE PITCH CONTROL ADJUSTMENTS

Some minor adjustments may be required due to floor types and conditions to extend downward travel. Remove clevis pin (3) and unscrew yoke (1) from cable (2). To adjust pitch (angle) of squeegee, loosen bolts (5) and knobs (4). Squeegee angular position can now be changed for best performance.

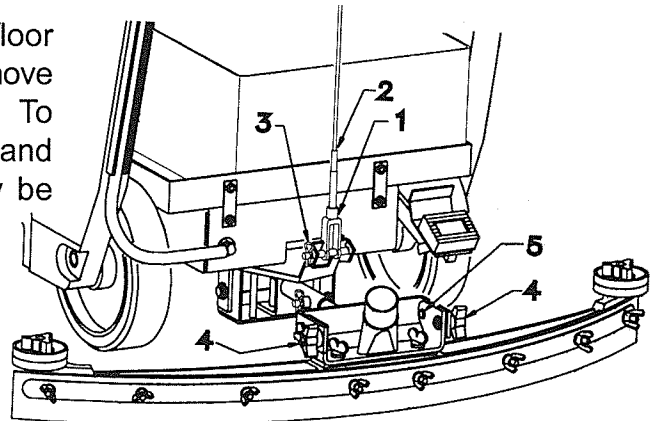

BRUSH INSTALLATION - REMOVAL

INSTALLATION - Figure 1

1. Disconnect power cable (mains) from machine.
2. Set brush assist lever (A) to rabbit.
3. Raise brush mechanism (B) to the "up" position by depressing pedal downward as shown.
4. Remove side skirt (C) by lifting up and away.
5. Center brush (D) under machine as shown lining up center hex drive hub.
6. By releasing foot pedal (B) to lower brush mechanism, drive hub will engage.

REMOVAL - Figure 2

1. Disconnect power cable (mains) from machine.
2. Set brush assist lever (A) to rabbit.
3. Raise brush mechanism (B) to "up" position by depressing pedal downward as shown.
4. Remove side skirt (C) by lifting up and away.
5. Brush has snap-on push-off clutch plate. By pushing brush away from machine and from side it will release brush assembly.

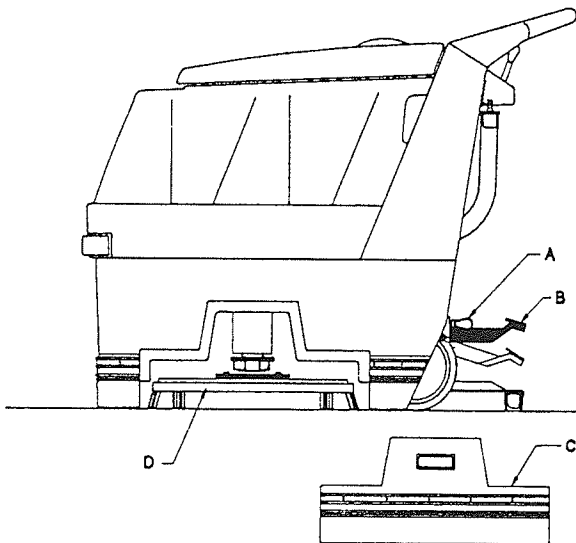

Fig. 1

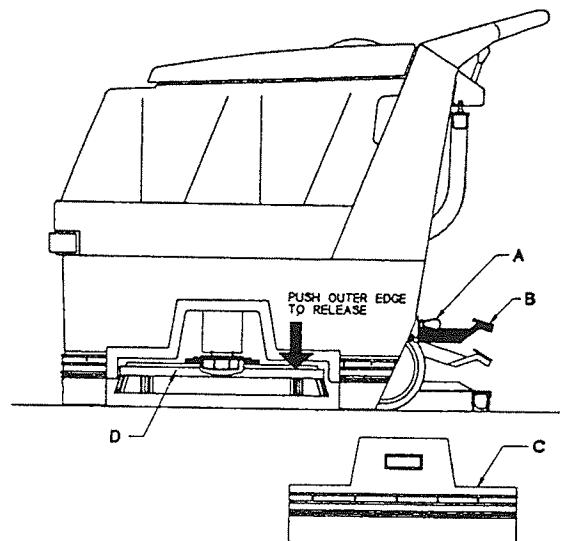

Fig. 2

OPERATING INSTRUCTIONS

1. Filling: Fill the solution tank with the desired amount of water and add liquid cleaning solution to the proper dilution ratio. **DO NOT USE** powdered cleaning chemicals. Powders are unlikely to dissolve thoroughly, resulting in clogging the in-line solution filter. This can reduce or stop water flow to the brush.
2. Lower brush assembly.
 - To lower the brush, first push the pedal slightly towards the center of the machine (unlock it), then release it slowly.
 - To lift the brush, press the pedal down until lift mechanism engages.
3. Turn on brush switch.
4. Adjust solution control feed lever.
5. Turn on vacuum switch.
6. Lower squeegee assembly.

After Use:

1. Turn off solution feed.
2. Switch off brush and raise.
3. Raise squeegee assembly.
4. Turn off vacuum motor.

Solution and recovery tanks should be emptied after every use.

MAINTENANCE: Unplug from outlet before servicing.

- | | |
|---------|--|
| Daily | 1. Clean float assembly & squeegee blades. |
| Monthly | 1. Check wear on squeegee blades.
2. Grease rear wheels.
3. Grease pivot points on brush motor assembly. |

Every 500 hours check condition of carbon brushes on vacuum motor and brush drive motor.

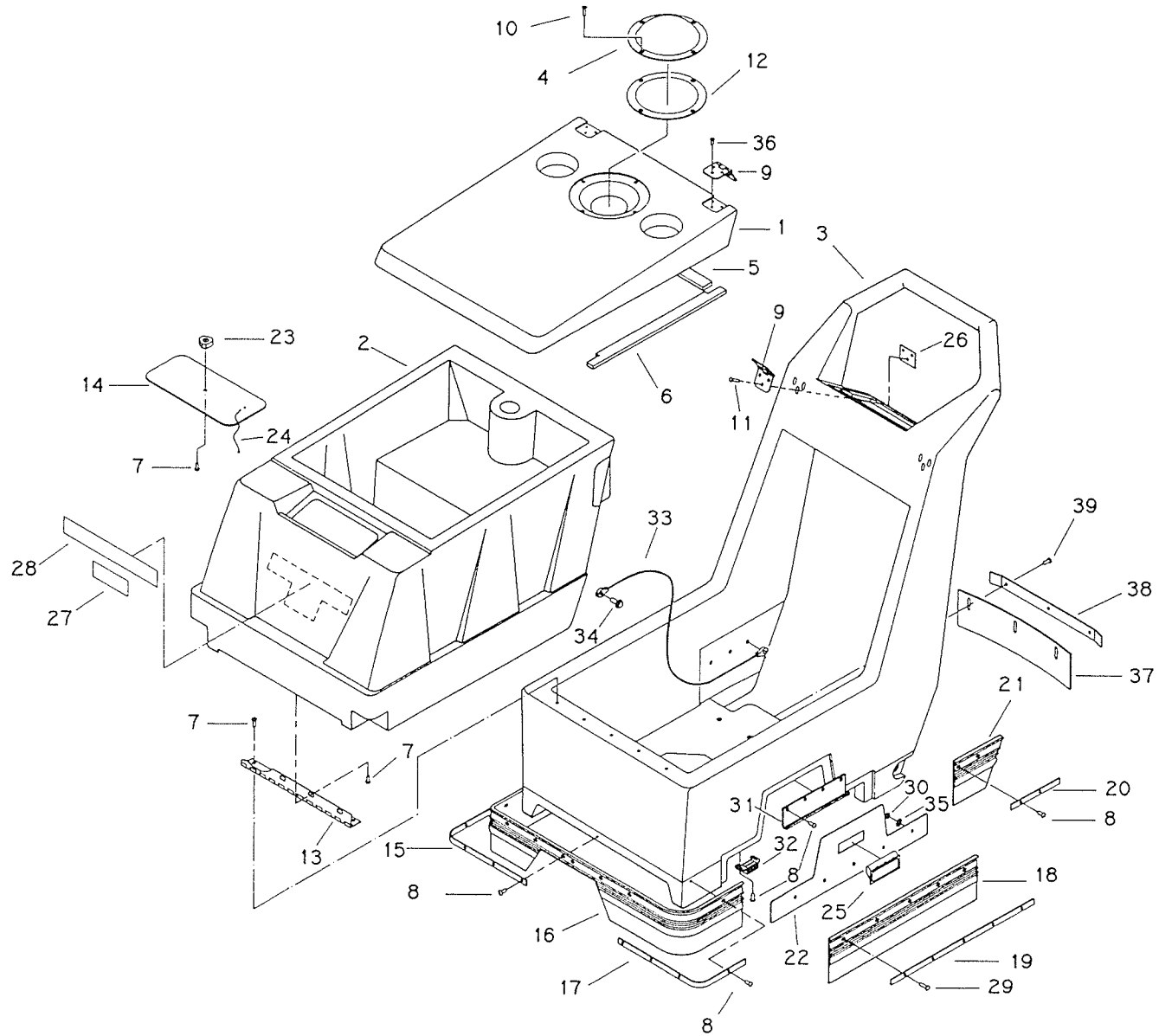

Parts List

Item	Part No.	Qty.	Description
1	210002	1	Lid Assembly Recovery
2	210001MCH	1	20" Solution/Recovery Tank Assembly
3	210000MCH	1	20" Base Assembly
4	210004	1	Recovery Dome
5	210006	2	Lid Gasket
6	210007	2	Lid Gasket
7	712565	10	SCR-MC 1/4-20 x .62 SS
8	711106	25	SCR-ST-A 10 x .75 PL
9	430044MCH	2	Hinge Lid 20"
10	712810	4	SCR-MC 10-24 x .37 STPL
11	712536	6	SCR-MC 10-24 x .62 SS TH
12	210005	1	Dome Gasket
13	260087	1	Hinge
14	450066	1	Solution Tank Cover
15	210055	1	Side Skirt Retainer
16	210052	1	Splash Skirt
17	210056	1	Skirt Retainer Front
18	210053	1	Skirt at Access Panel
19	210057	1	Skirt Retainer at Access Panel
20	210058	1	Skirt Retainer at Wheel
21	210054	1	Skirt at Wheel
22	210059	1	Access Panel
23	833214	1	Knob 3-Sided
24	450062	1	Cord, Nylon
25	210061	1	Pocket Pull
26	430126	2	Hinge Backing Plate
27	715089	1	Decal "200"
28	715060	1	Decal "Minuteman"
29	712822	5	No. 10-24 x .50 Lg. Screw
30	712900	5	Nut-Hex 10-24 STPL
31	210063	1	Access Panel Hanger
32	210027	2	Magnetic Catch
33	833463	1	Titl. Cable
34	712042	1	5/16-18 x .62 Wizz Bolt HH
35	711533	5	WSR-Internal Lock #10
36	712540	6	SCR-MC 10-24 x .37 SS TR
37	210077	1	Skirt
38	210078	1	Retainer
39	711104	3	SCR-ST 10 x .50

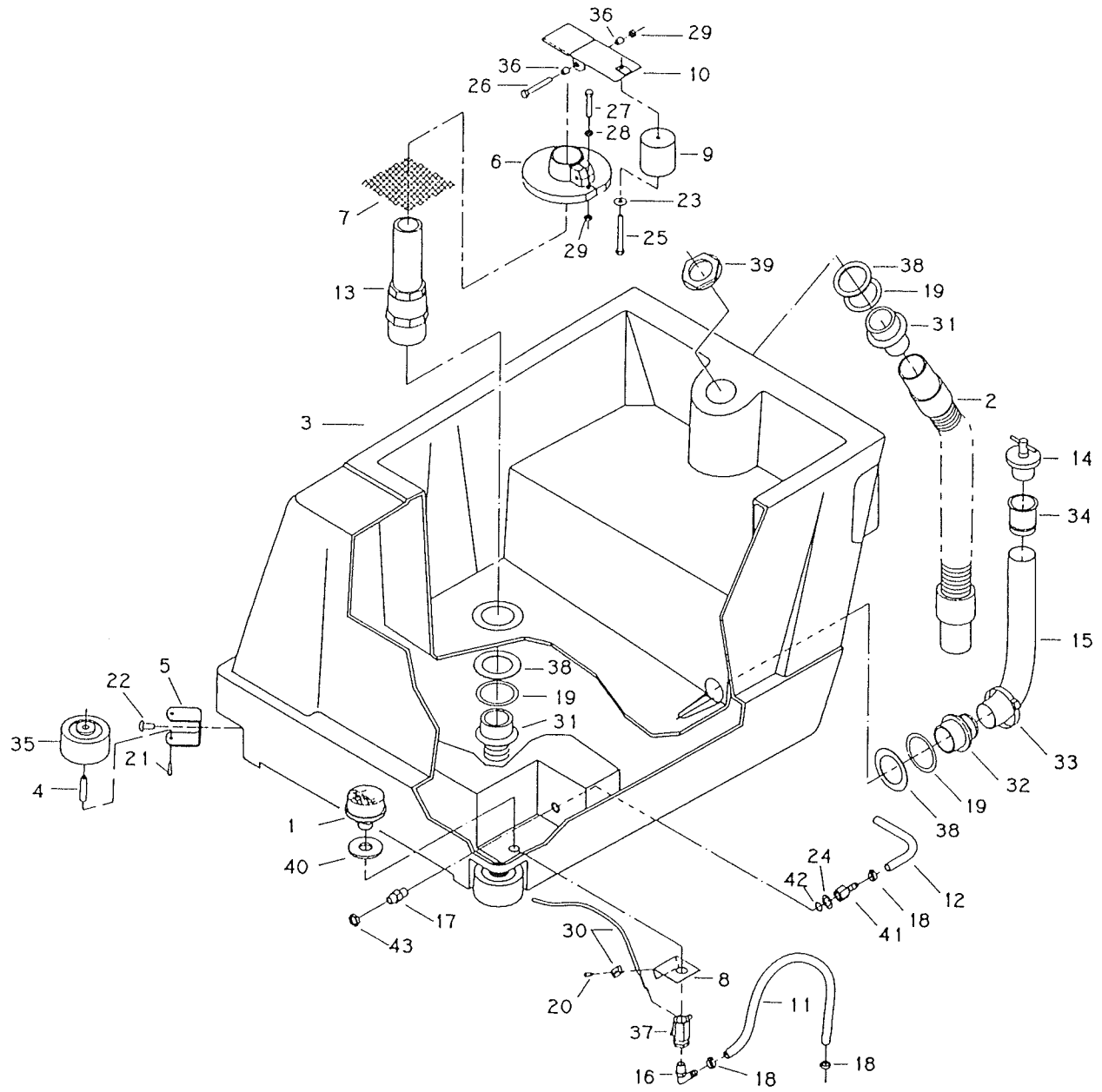

Parts List

Item	Part No.	Qty.	Description	Item	Part No.	Qty.	Description
1	130118	1	Solution Strainer M3-40	23	711504	1	WSR-Flat 1/4 ID SS
2	210068	1	Vac Recover Hose 34.5 C/L	24	711594	1	WSR-Flat .56 x .88 x .03 NI
3	210001MCH	1	Sol/Recovery Tank Assembly	25	712092	1	SCR Nylon 1/4-20 x 2.5
4	833254	2	Bumper Wheel Axle	26	712567	1	SCR-MC 1/4-20 x 2.00 SS
5	832949	2	U-Bracket Wheel Mount	27	712569	1	SCR-MC 1/4-20 x 1.50 SS
6	430041	1	Float Housing	28	712665	1	Nut-Hex 1/4-20 SS
7	430050	1	Filter Screen 4 x 4	29	712667	2	Nut-Hex 1/4-20 SS NYLOC
8	430058	1	Sol. Valve Cable Mount	30	430053	1	Solution Control Cable A
9	430089	1	Float	31	450083	1	Hose Adapter
10	430090	1	Float Valve Weldment	32	760220MCH	1	1.5 Adapter MCH (833310)
11	450056	1	Solution Hose Nylon 21"	33	760245	1	Hose Clamp 62P24
12	210073	1	Solution Dump Hose Nylon 41"	34	760343	1	Tube Hose 24/32B
13	210009	1	Standpipe Assembly	35	832896	2	Guide Wheel
14	833316	1	Drain Plug 1 1/4	36	762384	2	Bushing .277 x .375 x .37
15	210069	1	Black Drain Hose 32"	37	809413	1	Valve Solution
16	450040	1	Elbow Plt. 3/8 MPT x 3/8 BARB	38	828970	3	WSR Neop 1.81 x 2.37 x .9
17	450059	1	Brass Bulkhead Fitting	39	828971	1	Nut 1 1/2 Pipe Thread
18	450076	2	Crimp Clamp SS 185R	40	828975	1	WSR Neop .75 x 1.5 x .90
19	450081	3	WSR SS 1.908 x 2.41 x .03	41	833473	1	Hose BARB 1/4 FPT x 3/8 BARB
20	711124	1	SCR-ST-B 10 x .37 NI	42	832326	1	O Ring
21	710353	2	SCR-MC 10-32 x .37 ST PL	43	260183	1	1/4" NPT Plastic Nut
22	710985	2	SCR-SC 3/8-16 x .62				

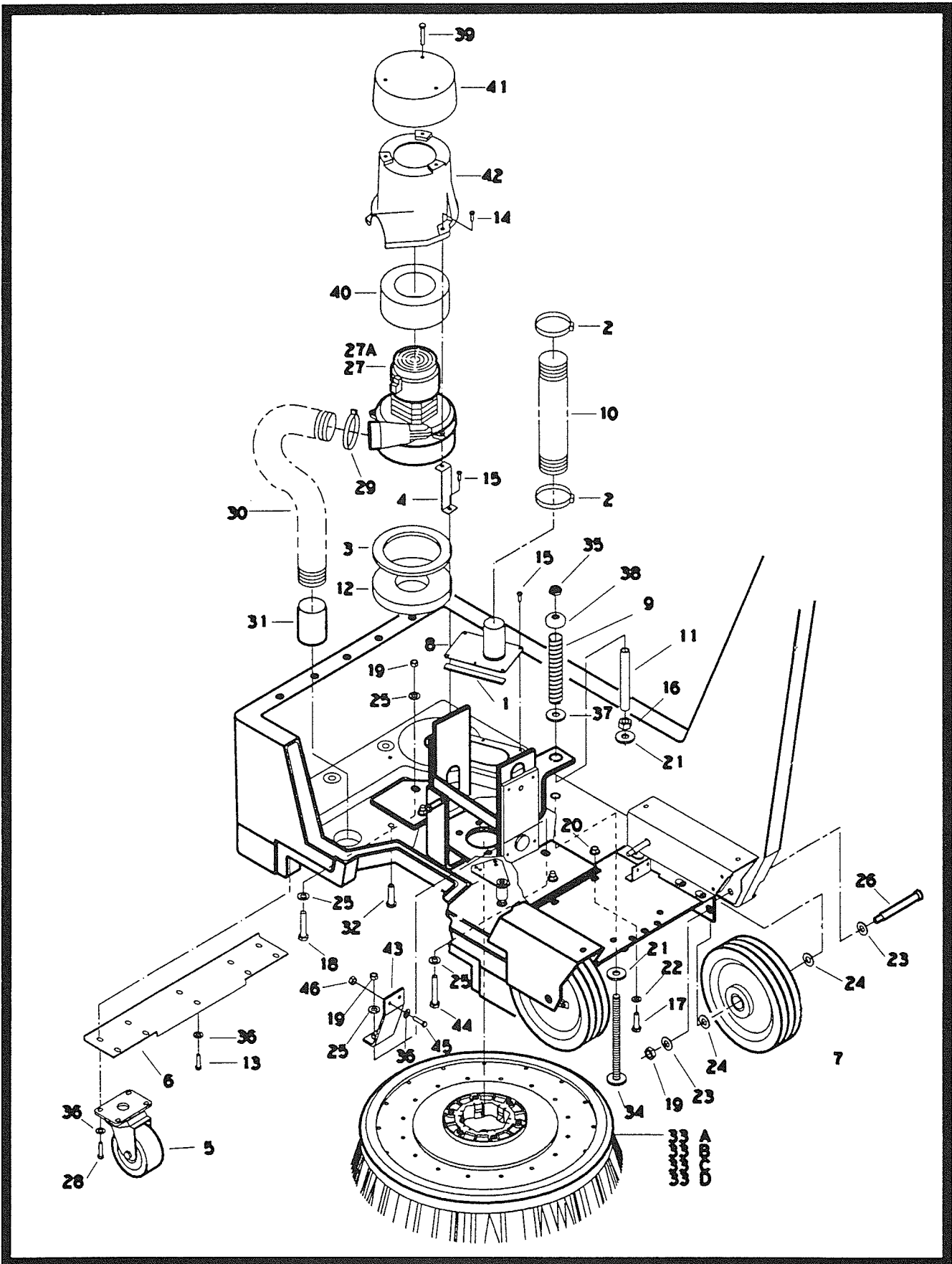

Parts List

Item	Part No.	Qty.	Description
1	250041	1	Seal, Rubber .12 x .62 x 14.5
2	270249	2	Hose Clamp
3	290017	1	Gasket, 4.31 x 5.81 x .19
4	430018	3	Z Bracket
5	762333	2	Caster 3.5"
6	210010	1	Caster Mtg. Brkt.
7	210003	2	8" Wheel
8	430069	1	Vacuum Manifold Assembly
9	828301	1	Spring Squeegee Pressure
10	210074	1	Vacuum Hose 1.5 x 31 C/L
11	430148	1	Sleeve
12	460019	1	Gasket 3.75 x 5.75 x .75
13	710178	2	SCR-MC 1/4-20 x .50 STPL
14	710182	3	SCR-MC 1/4-20 x 1.00
15	711106	9	SCR-ST-A 10 x .75 PL
16	711437	1	Nut-Hex 1/2-13 NIPL
17	711231	4	BLT-HH 5/16-18 x 1.25 STPL
18	711243	5	BLT-HH 3/8-167 x 1.5 STPL
19	711380	8	Nut-Nyloc 3/8-16
20	711425	3	Nut-Flanged Wizz 1/4-20
21	711510	2	WSR-Flat .5 x 1.37 x .10
22	711506	4	WSR-Flat 5/16 STPL
23	711509	6	WSR-Flat 1/2 STPL
24	711517	4	WSR-Flat .77 x 1.37 x .03
25	711515	6	WSR-Flat .44 x .87 x .07
26	710874	2	SCR-SC 1/2 x 13 x 3.75
27	740429	1	Vac Motor 115V Model
27A	741030	1	Vac Motor 240V Model
28	710180	8	SCR-MC 1/4-20 x .75
29	760859	1	Hose Clamp
30	210075	1	Hose Rubber Flex 2 x 15"
31	801013	1	Sleeve, Hose
32	832136	1	Nylon Sleeve Solution Feed
33A	381041	1	Strata-Grit Brush
33B	381040	1	Poly-Grit Brush
33C	381039	1	Nylon Brush Assembly Complete
33D	381038	1	Pad Holder
34	430145	1	Pressure Adjust Rod
35	364-816	1	Nut-Nyloc 1/2-13 Half
36	711505	11	WSR-Flat 1/4
37	711512	1	WSR-Flat .75 x 1.37 x .08
38	828264	1	Washer Cup
39	711160	3	#10 Hi/Lo Screw x .63
40	380064	1	Foam Ring
41	840011	1	Vac Motor Cover, Top
42	840012	1	Vac Motor Cover, Bottom
43	210098	1	Reinforcing Bracket
44	711244	1	BLT-HH 3/8-16 x 1.75
45	711204	1	BLT-HH 1/4-20 x .75
46	711373	1	Nut-Nyloc 1/4-20

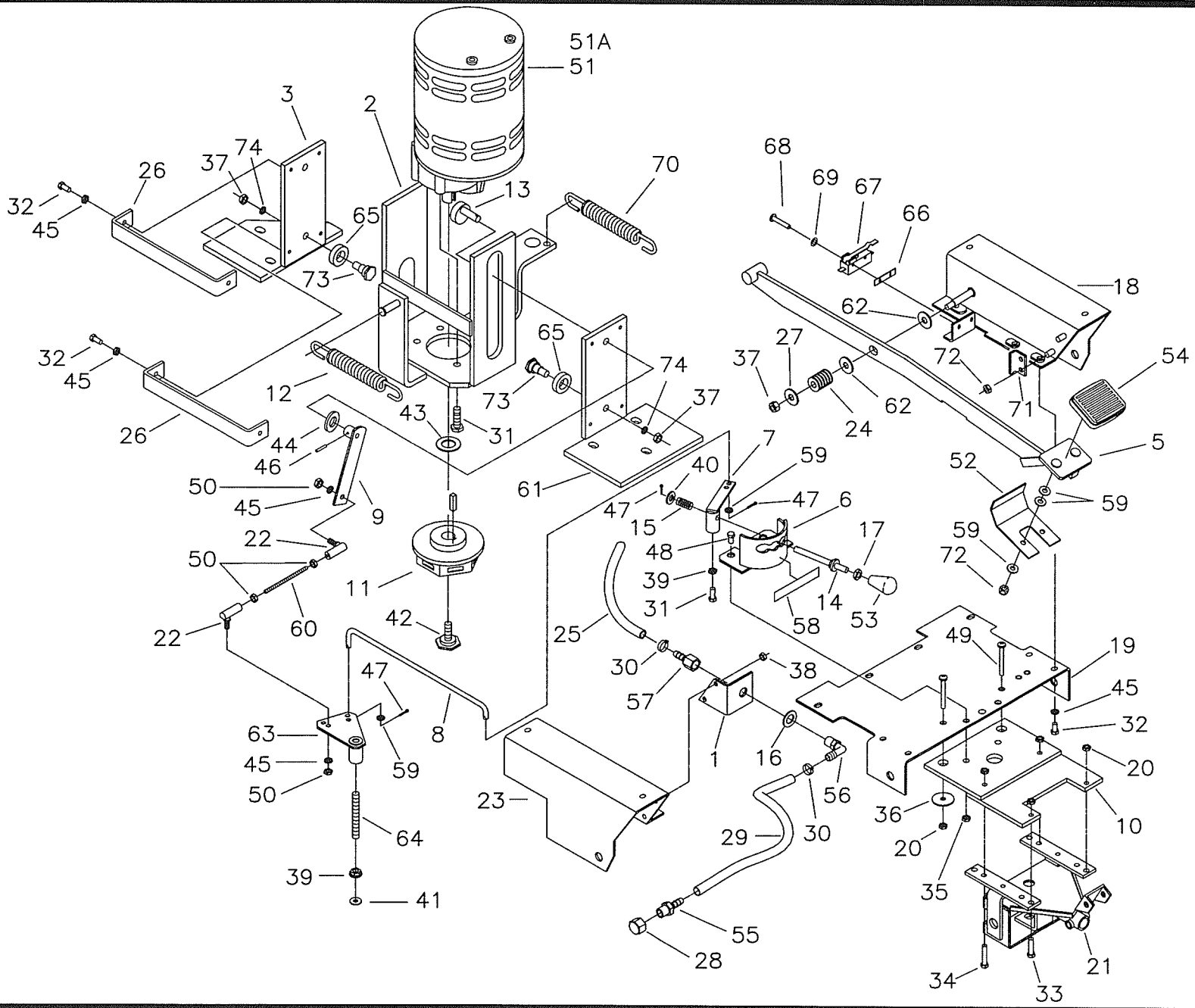

Parts List

Item	Part No.	Qty.	Description	Item	Part No.	Qty.	Description
1	100000	1	Mounting Brkt. Quick Disc	39	711439	2	Nut-Flanged Wizz 3/8-16
2	210042	1	Motor Mount Weldment	40	711506	3	WSR-Flat 5/16 STPL
3	210110	1	Motor Brkt. Weldment	41	711515	1	WSR-Flat .44 x .87 x .07
5	210039	1	Lift Lever Weldment	42	210066	1	Drive Hub Retainer Bolt
6	430019	1	Speed Control Weldment	43	711517	1	WSR-Flat .77 x 1.37 x .03
7	430022	1	Control Pivot Weldment	44	711523	2	WSR-Wave .37 x .68 x .02
8	210030	1	Speed Control Rod	45	711535	10	WSR-Helical .26 x .50 x .02
9	430026	1	Speed Control Weldment	46	711615	1	Rollpin .12 x .75
10	210126	1	Mounting Plate Weldment	47	711803	3	Cotter Pin .06 x .75
11	430035	1	Drive Hub	48	712042	3	Bolt-WSR HH 5/16-18 x .62
12	210035	1	Spring, Extension	49	712576	2	SCR-MC 1/4-20 x 1.25 SS
13	430054	1	Pivot Cam	50	712666	4	Nut-Hex Jam 1/4-28 SS
14	430055	1	Threaded Connecting Rod	51	740428	1	Gearmotor 115V
15	430056	1	Compression Spring	51A	740432	1	Gearmotor 230V
16	711579	1	WSR-Flat .56 x 1.00	52	210076	1	Foot Guard
17	711420	1	Nut-Hex Jam 5/16-18 STPL	53	760592	2	Knob Oval Tapered
18	210016	1	Wheel Mount Strut Right	54	210142	1	Pedal Pad
19	210011	1	Mtg. Plate Wheel Carriage	55	828952	1	3/8 Barb x 1/4 MPT
20	712667	6	Nut-Hex 1/4-20 SS	56	833325	1	Elbow Pls. 1/4 MPT x 3/8 Barb
21	210455	1	Squeegee Mechanism Complete	57	833473	1	Hose Barb 1/4 FPT x 3/8 Barb
22	430080	2	Balljoint (SP1002)	58	715136	1	Decal Diecut Speed Control
23	210015	1	Wheel Mount Strut Left	59	711505	8	WSR-Flat 1/4
24	210047	1	Die Spring	60	210028	1	1/4-28 x 2.00 Threaded Rod
25	210073	1	Solution Dump Hose, Nylon 41"	61	210108	1	Motor Brkt. Weldment
26	430106	2	Stabilizer Bar Lower	62	210033	1	Olilite-WSR
27	711509	1	WSR-Flat 1/2	63	210031	1	Pivot Weldment
28	430114	1	Nylon Cap 1/4 FPT HC4	64	210029	1	3/8-16 U.N.C. Threaded Rod
29	430118	1	Clear Dump Hose C/L 24"	65	361254	2	Bearing
30	450076	2	Crimp Clamp SS 185R	66	711443	1	Tinnerman Clip
31	710986	5	SCR-SC 3/8-16 x 1.00 STPL	67	740129	1	Switch
32	711202	10	BLT-HH 1/4-20 x .50 STPL	68	710307	2	SCR-MC 6-32 x 1.00
33	712564	2	BLT-HH 1/4-20 x 1.00	69	711551	2	WSR-Flat
34	712566	2	BLT-HH 1/4-20 x 1.25	70	260211	1	Spring
35	712683	2	Nut-Nyloc 5/16-18 SS	71	210387	1	Pedal Stop
36	712761	2	WSR-Flat .28 x 1.25 x .059 SS	72	711373	4	Nut-Nyloc 1/4-20
37	711328	2	Nut-Hex 3/8-16	73	210124	2	Bearing Stud
38	711425	4	Nut-Flanged Wizz 1/4-20	74	711546	2	WSR-Helical 3/8

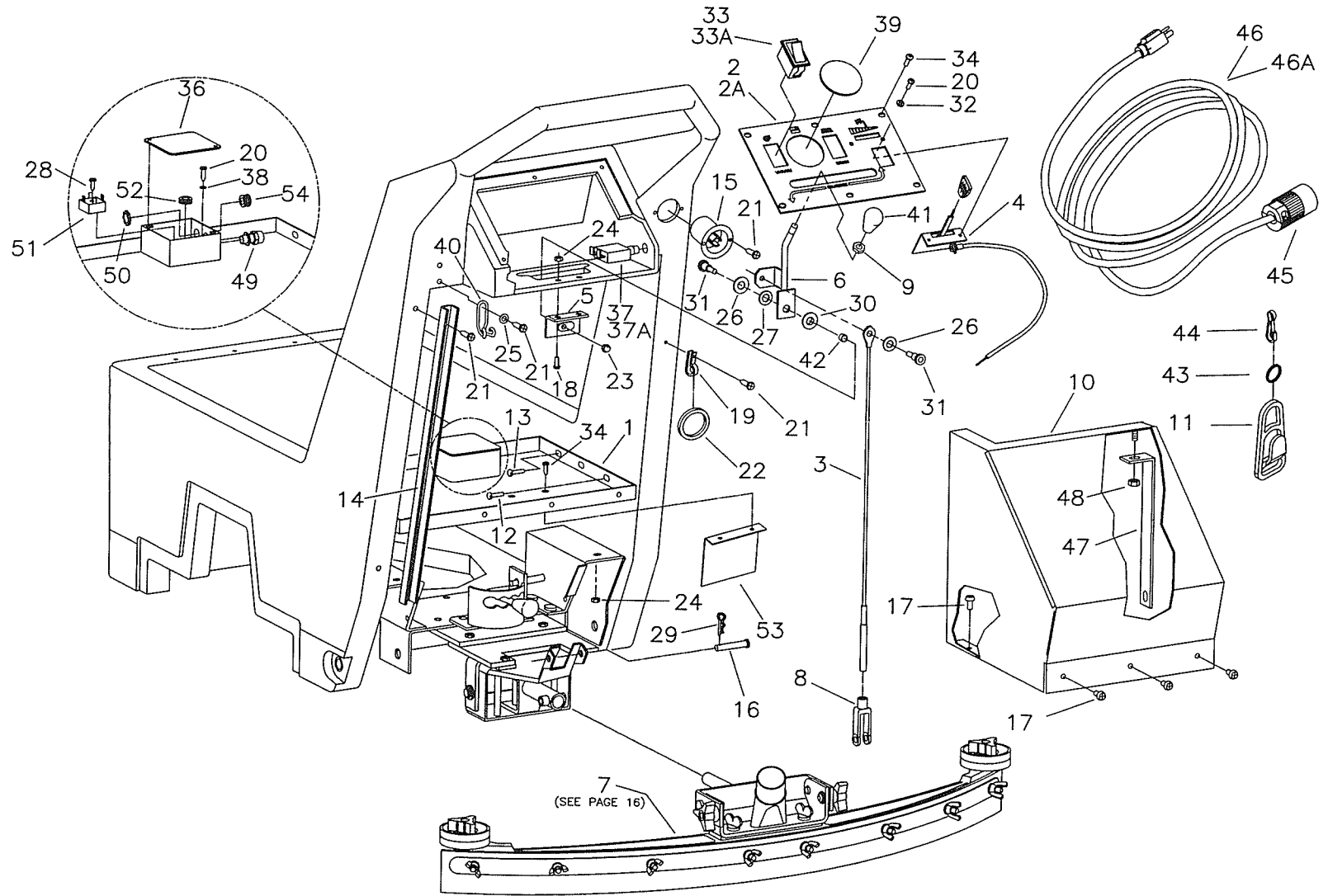

Parts List

Item	Part No.	Qty.	Description	Item	Part No.	Qty.	Description
1	210095	1	Wheel Mount Frame	30	829014	1	Flanged Bushing
2	210026SP	1	Dashboard, Screen Printed	31	712041	2	BLT-SDER 1/4-20 x .44 x .37
2A	210026CESP	1	Dashboard, CE Screen Printed	32	712320	2	WSR-Nylon .22 x .45 x .04
3	210406	1	Squeegee Lift Cable	33	809754	2	Switch Rocker
4	210045	1	Solution Control Cable	33A	740711CE	2	Switch (CE Version)
5	430059	1	Squeegee Lift Brkt. Assembly	34	712822	8	SCR-THMS 10-24 x .50 STPL
6	430060	1	Squeegee Lift Arm Assembly	35			
7	210452	1	Squeegee Assembly Complete	35A			
8	881009	1	Yoke	36	805634	1	Cover, Box
9	711420	1	Nut-Hex Jam 5/16-18	37	740220	1	CB 20 amp 115V Model
10	210092	1	Back Cover Weldment	37A	740106	1	CB 9 amp 230V Model
11	450012	1	Cord Strain Relief	38	711553	1	WSR-Internal Lock #10
12	710197	1	SCR-MC 5/16-18 x .75 STPL	39	833823	1	Hole Plug
13	710195	5	SCR-MC 5/16-18 x .50 STPL	40	760286	1	Wire Formed Hook
14	430120	1	U Channel	41	760592	1	Knob Oval Tapered
15	830540	1	Twist Loc Receptacle	42	762058	1	Spacer .319 x .375 x .250
16	210415	1	Clevis Pin .312 x 1.69	43	760142	1	Clamp Ring
17	710178	4	SCR-MC 1/4-20 x .50 STPL	44	430103	1	Snap Body
18	710180	2	SCR-MC 1/4-20 x .75 STPL	45	828796	1	Female Connector Nylon
19	250038	1	Retainer Bag Clip	46	830292	1	Cord Assembly 115V
20	711124	3	SCR-ST-B 10 x .37 NI	46A	740477	1	Cord Assembly 240V
21	711161	5	SCR HI/LO 10 x 3/4 PL	47	210093	1	Wire Support
22	833827	1	O-Ring 1.25 ID x .187	48	711316	1	1/4-20 Nut
23	711352	1	Nut-Acorn 1/4-20 ST N1	49	450050	2	Heyco Bushing Liquid Tight
24	711425	4	Nut-Flanged Wizz 1/4-20	50	711400	2	Nut-Pipe Lock 1/2
25	711503	2	WSR-Flat #10	51	740202	1	Rect. Bridge 50A 600V IMP
26	711506	2	WSR-Flat 5/16 STPL	52	762299	1	Grommet .50 x .09 x .75
27	711523	1	WSR-Wave .37 x .68 x .02	53	210096	1	Switch Guard
28	711106	1	SCR-ST-A 10 x .75 PL	54	250135	1	Grommet
29	711808	1	Cotter Pin-Hair #13				

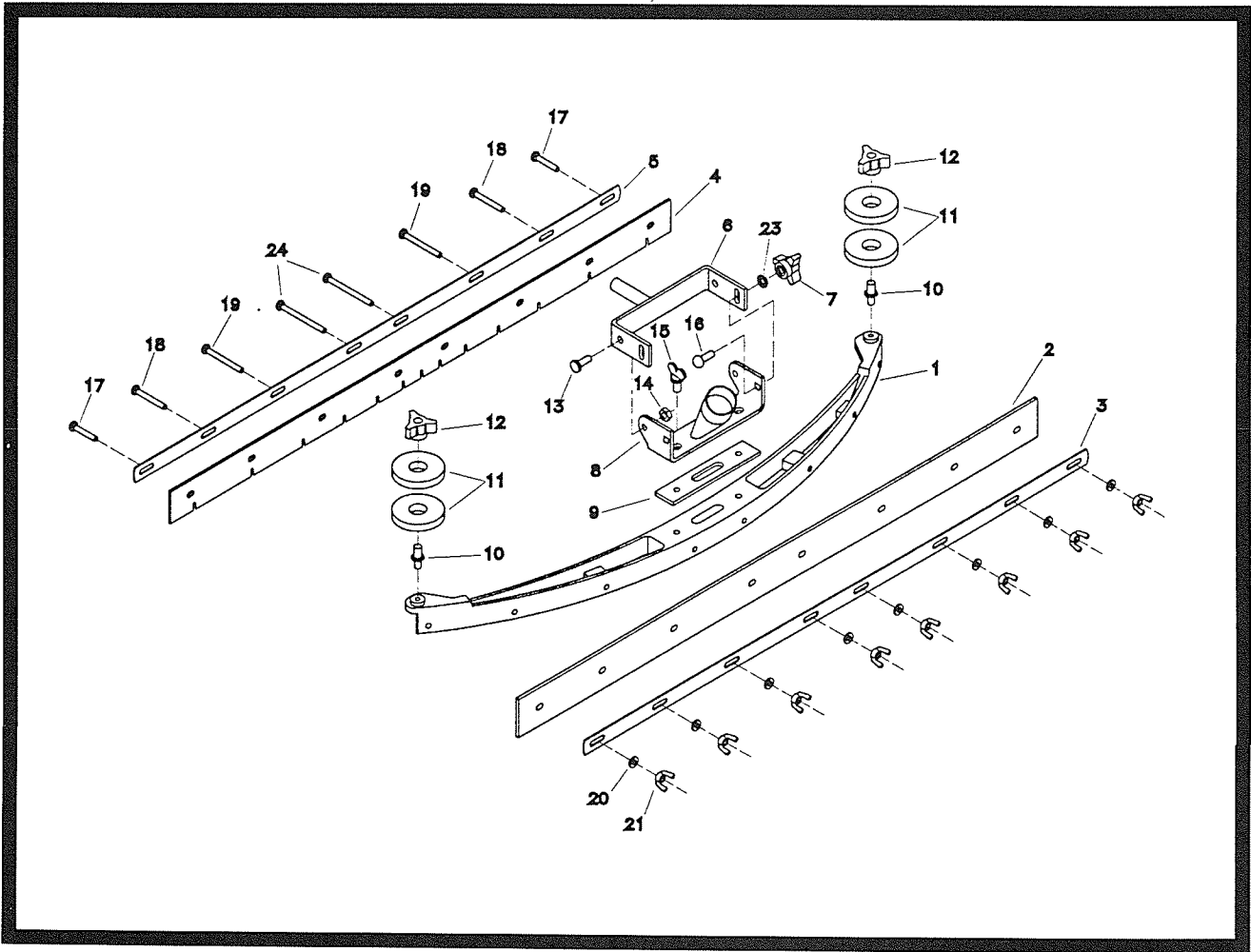

Parts List

Item	Part No.	Qty.	Description
1	210351MCH	1	Squeegee Casting
2	210352	1	Rear Squeegee Blade
3	210353	1	Rear Squeegee Strap
4	210354	1	Front Squeegee Blade
5	210355	1	Front Squeegee Strap
6	210381	1	Pitch Control Bracket
7	210118	2	Knob 3-Sided 5/16 Nyloc
8	210357	1	Tube Bracket
9	210390	1	Squeegee Gasket
10	430075	2	Threaded Insert
11	430085	4	Squeegee Bumper Wheel
12	430074	2	Adjusting Nut
13	710975	2	SCR-SC 5/16-18 x .87 BH
14	711374	2	Nut-Nyloc 5/16-18
15	260267	2	Wing Bolt 3/8-16 x .75
16	70-516-16	2	Bolt -Carr 5/16 x 1.00
17	712571	2	Bolt-SS Carr 1/4-20 x 1.50
18	712572	2	Bolt-SS Carr 1/4-20 x 2.00
19	712573	2	Bolt-SS Carr 1/4-20 x 2.50
20	711504	8	WSR-Flat .25 x .56 SS
21	712668	8	Wing Nut 1/4-20 SS
22	210102	1	Reinforcing Blade
23	711539	2	WSR-External Lock 3/8
24	712574	2	Bolt-SS Carr 1/4-20 x 3.00

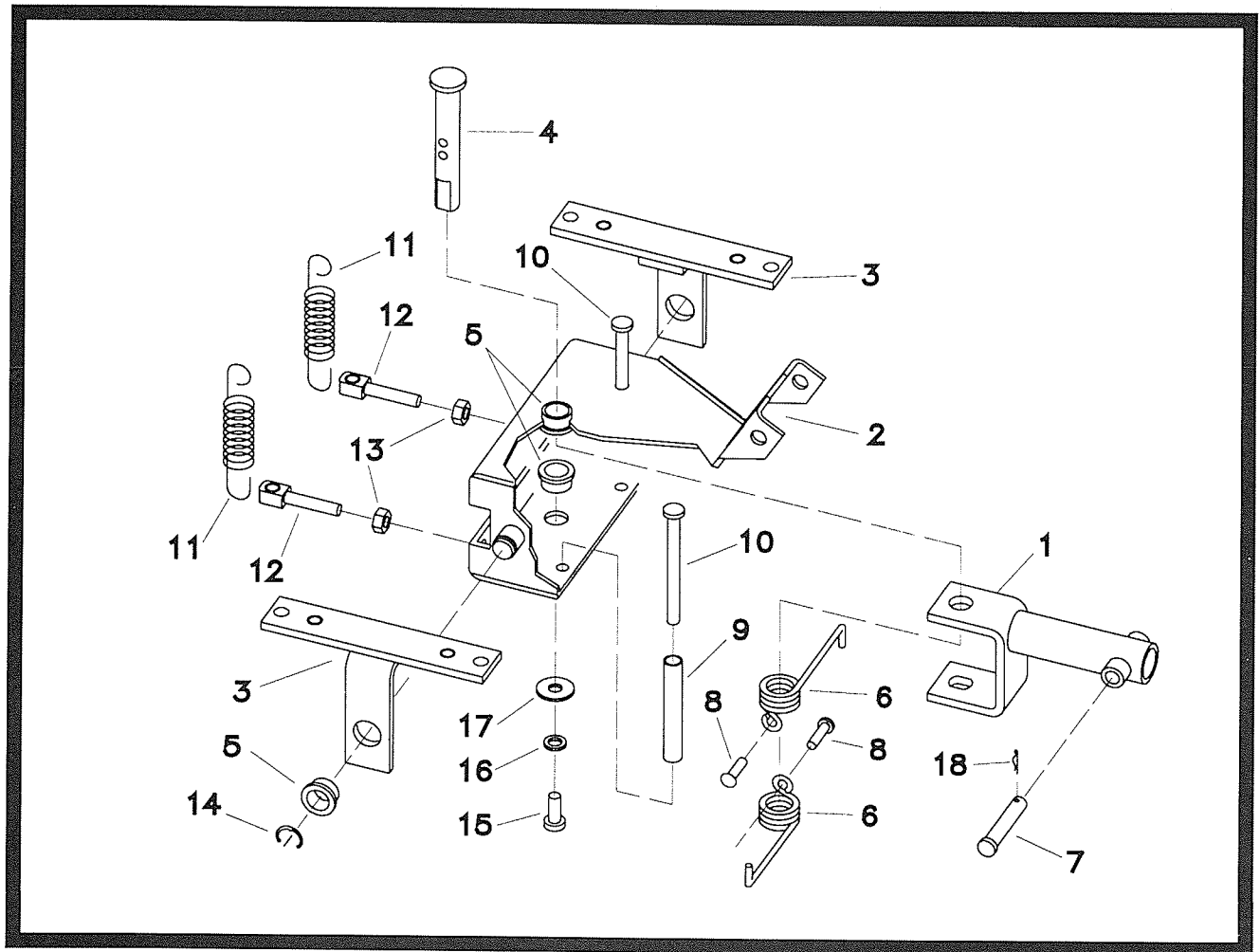

Parts List

Item	Part No.	Qty.	Description
1	210379	1	Yoke Weldment
2	210372	1	Spring Housing Weldment
3	210392	2	Pivot Bracket Weldment
4	210375	1	Swivel Pin
5	260041	4	½ Oilite Bushing
6	210391	2	Torsion Spring SS
7	210415	1	Clevis Pin
8	712811	2	SCR-MC 10-24 x .50
9	210400	2	Spacer Tube
10	710592	2	SCR-MC ¼-20 x 2.75
11	210413	2	Return Spring
12	260292	2	Swing Bolt
13	711316	2	Nut-Hex ¼-20
14	711713	2	½ Retaining Ring
15	710180	1	SCR-MC ¼-20 x .75
16	711535	1	WSR-Helical ¼
17	711519	1	WSR-Flat .25 x 1.00 x .06
18	711808	1	Cotter Pin

WIRING DIAGRAM, 115V, STANDARD 230V

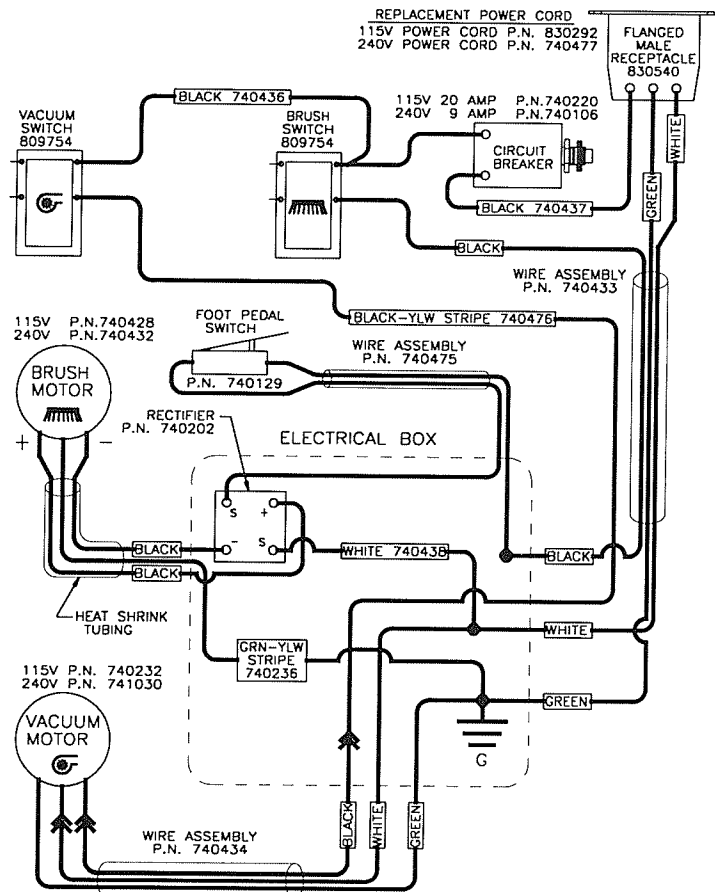

WIRING DIAGRAM, 230V CE

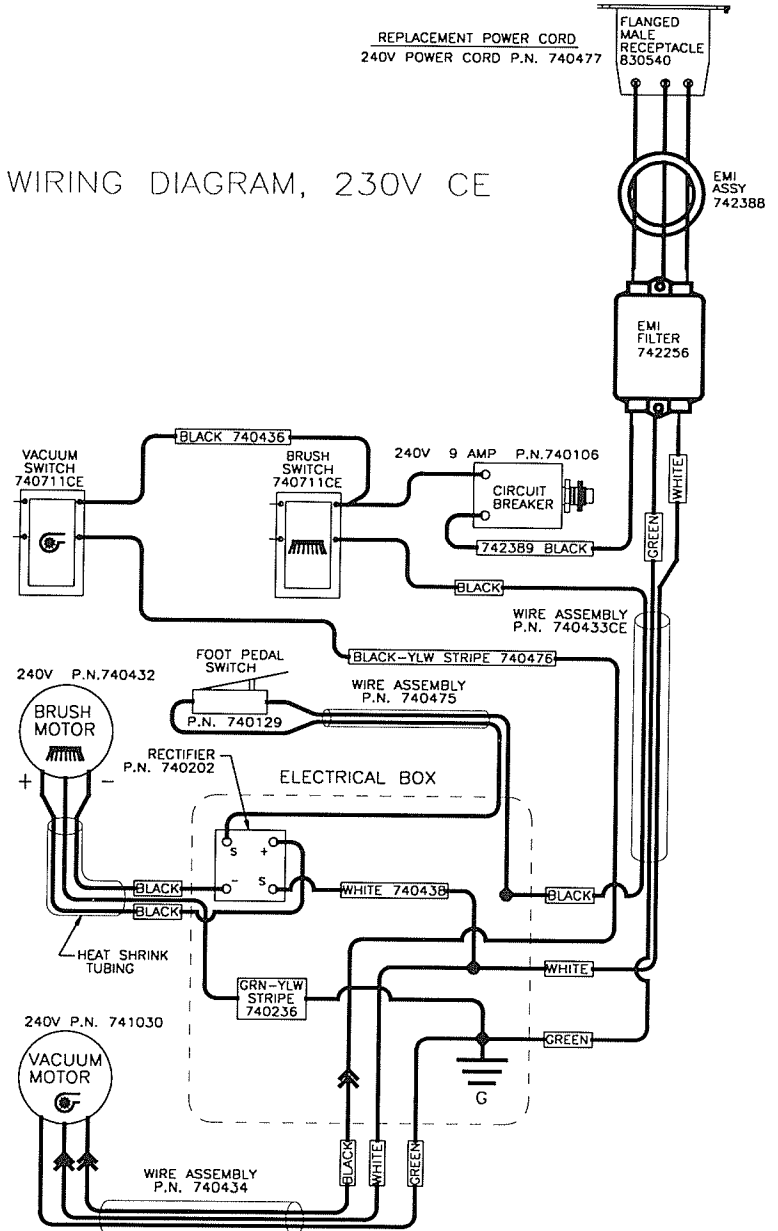

LIMITED WARRANTY

Minuteman International, Inc. warrants to the original purchaser/user that this product is free from defects in workmanship and materials under normal use and service for a period of three years from date of purchase. In addition, Minuteman International, Inc. will, at its option, honor labor warranty claims for the first 12 months from date of sale, provided such claims are submitted through and approved by factory authorized repair stations. Minuteman International, Inc. will, at its option, repair or replace without charge, except for transportation costs, parts that fail under normal use and service when operated and maintained in accordance with the applicable operation and instruction manuals.

This warranty does not apply to normal wear, or to items whose life is dependent on their use and care, such as belts, cords, switches, hoses, rubber parts, electrical motor components or adjustments. Parts not manufactured by Minuteman International, Inc. such as engines, batteries, battery chargers, hydraulic pumps, and tires are covered by and subject to the warranties and/or guarantees of their manufacturers. Please contact Minuteman International, Inc. for procedures in warranty claims against these manufacturers.

Special warning to purchaser — Use of replacement filters and/or prefilters not manufactured by Minuteman International, Inc. or its designated licensees, will void all warranties expressed or implied.

A potential health hazard exists without exact original equipment replacement.

All warranted items become the sole property of Minuteman International, Inc. or its original manufacturer, whichever the case may be.

Minuteman International, Inc. disclaims any implied warranty, including the warranty of merchantability and the warranty of fitness for a particular purpose. Minuteman International, Inc. assumes no responsibility for any special, incidental or consequential damages.

This limited warranty is applicable only in the U.S.A. and Canada, and is extended only to the original user/purchaser of this product. Customers outside the U.S.A. and Canada should contact their local distributor for export warranty policies. Minuteman International, Inc. is not responsible for costs or repairs performed by persons other than those specifically authorized by Minuteman International, Inc. This warranty does not apply to damage from transportation, alterations by unauthorized persons, misuse or abuse of the equipment, use of non-compatible chemicals, or damage to property, or loss of income due to malfunctions of the product.

If a difficulty develops with this machine, you should contact the dealer from whom it was purchased.

This warranty gives you specific legal rights, and you may have other rights which vary from state to state. Some states do not allow the exclusion or limitation of special, incidental or consequential damages, or limitations on how long an implied warranty lasts, so the above exclusions and limitations may not apply to you.

Minuteman[®]

World Headquarters

Minuteman International, Inc.
111 South Rohlwing Road
Addison, Illinois 60101

Minuteman Canada, Inc.

2210 Drew Road
Mississauga, Ontario
L5S 1B1

(630) 627-6900
FAX (630) 627-1130

(905) 673-3222
FAX (905) 673-5161

988110
Printed in U.S.A.