



Electronic Service Manuals

This electronic document is provided as a service to our customers. We do not create the contents of the information contained in this document. Should you have detailed questions pertaining to the information contained in this document, you may contact Michco, or the manufacturer which provided the original information in this electronic deliverable. Michco's only part in this electronic deliverable was the electronic assembly process.

You may contact Michco through the following methods:
Phone (517) 484-9312 or (800) 331-3339 MI, OH, IN only
2011 N. High St. -- Lansing, Michigan -- 48906
Fax: (517) 484-9836
Email: CustServ@Michco.com
Web site: www.Michco.Com
Parts Web site: www.FloorMachineParts.Com

Order Parts on Line at:
www.FloorMachineParts.Com

Directly to Parts & Service:
By Email: **Shop@Michco.com**
By Fax: (517) 702-2041
By Voice: Use numbers above.

Serving the Cleaning Industry Since 1922

Notice: All copyrighted material remains property of original owners, all trademarks are property of respective owners. Manuals are subject to Manufacturer's reproduction limitations. Originals or reproductions were provided by manufacturers through a request. We make no warranty as to the correctness of information provided in this document and you assume all risk.

170 Electric Floor Scrubber

Model: MC17115-00
MC17230-00
MC17230-00CE

■ OPERATION ■ SERVICE ■ PARTS ■ CARE



Revised 5/01

Minuteman[®]

TABLE OF CONTENTS

	Page
Safety Instructions	1
Electrical Requirements	2
Control Panel Identification	3
Brush Installation Instructions	4
Operating Instructions/ Maintenance	5
Main Polyethelene Components	6 & 7
Solution/Recovery Tank	8 & 9
Vacuum Components	10 & 11
Brush Drive Assemblies	12 & 13
Back Panel	14 & 15
Wiring Diagram	16

EC Declaration of Conformity

according to Directives 72/23, 89/392, and 89/336

We, Minuteman International Incorporated, of 111 South Rohlwing Road Addison Illinois 60101 USA, declare under our sole responsibility that the product MC17230-00CE Commercial Automatic Floor Scrubber to which this declaration relates corresponds to the relevant requirements of the EC Directives 72/23, 89/392 and 89/336. The following standards were used to determine compliance with the Directives: EN 292, EN 294, EN 811, EN 55014, EN 55104 and IEC 335-1-72.

SOUND		VIBRATION						
84 dB Operator	81dB At 3m	2.6 m/s² At Operators Handle						
<p>Tests were conducted on 4/21/97 with calibrated sound and vibration equipment under the conditions noted below:</p> <table style="width: 100%; border: none;"> <tr> <td style="width: 33%;">General Condition: Indoors</td> <td style="width: 33%;">Wind: 0 km/hr</td> </tr> <tr> <td>Temperature: 23°C</td> <td>Humidity: 70%</td> </tr> <tr> <td>Barometric Pressure: 29.5</td> <td></td> </tr> </table>			General Condition: Indoors	Wind: 0 km/hr	Temperature: 23°C	Humidity: 70%	Barometric Pressure: 29.5	
General Condition: Indoors	Wind: 0 km/hr							
Temperature: 23°C	Humidity: 70%							
Barometric Pressure: 29.5								

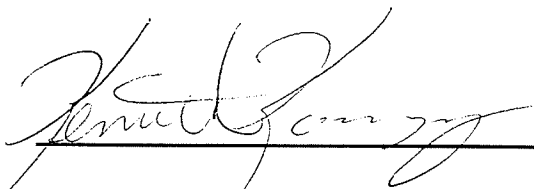

Kenneth Kaczmarz, Standards Engineer

4/21/97

Date

FOR COMMERCIAL USE ONLY

IMPORTANT SAFETY INSTRUCTIONS

When using an electrical appliance, basic precautions should always be followed, including the following:

READ ALL INSTRUCTIONS BEFORE USING

WARNING - To reduce the risk of fire, electric shock, or injury:

- Do not leave appliance when plugged in. Unplug from outlet when not in use and before servicing, cleaning or maintaining.

WARNING

To reduce the risk of electric shock - Do not expose to rain. Store indoors.

- Do not allow to be used as a toy. Close attention is necessary when used by or near children.
- This machine shall be used only by instructed and authorized persons.
- Use only as described in this manual. Use only manufacturer's recommended attachments.
- Inspect cord regularly. Do not use with damaged cord or plug. If appliance is not working as it should, has been dropped, damaged, left outdoors, or dropped into water, return it to a service center. Use only cord specified by manufacturer.
- Do not pull or carry by cord, use cord as a handle, close a door on cord, or pull cord around sharp edges or corners. Do not run appliance over cord. Keep cord away from heated surfaces.
- Do not unplug by pulling on cord. To unplug, grasp the plug, not the cord.
- Do not handle plug or appliance with wet hands.
- Do not put any object into openings. Do not use with any opening blocked; keep free of dust, lint, hair, and anything that may reduce air flow.
- Keep hair, loose clothing, fingers, and all parts of body away from openings and moving parts.
- Do not pick up anything that is burning or smoking, such as cigarettes, matches, or hot ashes.
- Do not use without dustbag and/or filters in place.
- Turn off all controls before unplugging.
- Use extra care when cleaning on stairs.
- Do not use to pick up flammable or combustible liquids such as gasoline or use in areas they may be present.
- Connect to a properly grounded outlet only. See grounding instructions.
- This machine is not suitable for picking up hazardous dust.
- Close tank and lid before use.

SAVE THESE INSTRUCTIONS

INSPECTION

Carefully unpack and inspect your machine for shipping damage. Each unit is tested and thoroughly inspected before shipment, and any damage is the responsibility of the delivery carrier who should be notified immediately.

WARNING

- Read Instruction Manual before operating this piece of equipment.
- To reduce the risk of fire use only commercially available floor cleaners and waxes intended for machine application.
- To reduce the risk of electrical shock, do not expose to rain. Store indoors.
- Do not cross over supply cord, hazard exists when rotating brush crosses over the cord.
- Electrical motors and components can cause an explosion when operated near volatile materials and vapors. Do not use this machine near flammable materials such a solvents, thinners, fuels, grain dust, etc.

ELECTRICAL

(Model MC17115-00) This floor machine is designed to operate on a standard 15 amp. 120 volt, 60 hz, AC circuit. Voltages below 105 volt AC or above 125 volts AC could cause serious damage to the motor.

(Model MC17230-00) This machine is designed to operate on a standard 16 amp type L fused 230 volt, 50 hz, AC circuit. Voltages below 200 volts AC or above 250 volts AC could cause serious damage to the motor I.E.C. Class 1.

GROUNDING INSTRUCTIONS

- This floor finishing machine should be grounded while in use to protect the operator from electric shock. The machine is equipped with a three-prong grounding type attachment plug to fit the proper grounding type receptacle. The green (or green and yellow) conductor in the cord is the grounding wire. Never connect this wire to other than the grounding blade.
- Floor Finishing Machines Rated Less Than 150 Volts - If the machine is provided with an attachment plug as shown in Sketch A it is intended for use on a 120-volt (nominal) circuit. If a properly grounded receptacle as shown in Sketch A is not available, an adapter as shown in Sketch C is available and should be installed as shown in Sketch B if the outlet box that houses the receptacle is grounded. Be sure to fasten the grounding tab with the faceplate screw.

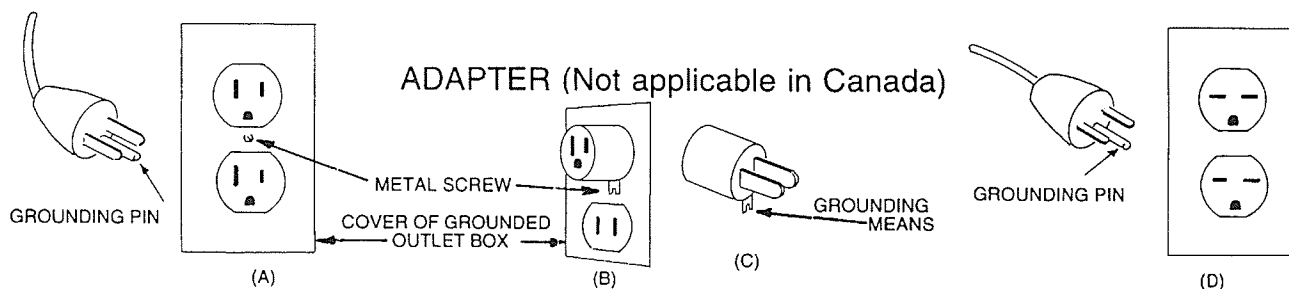

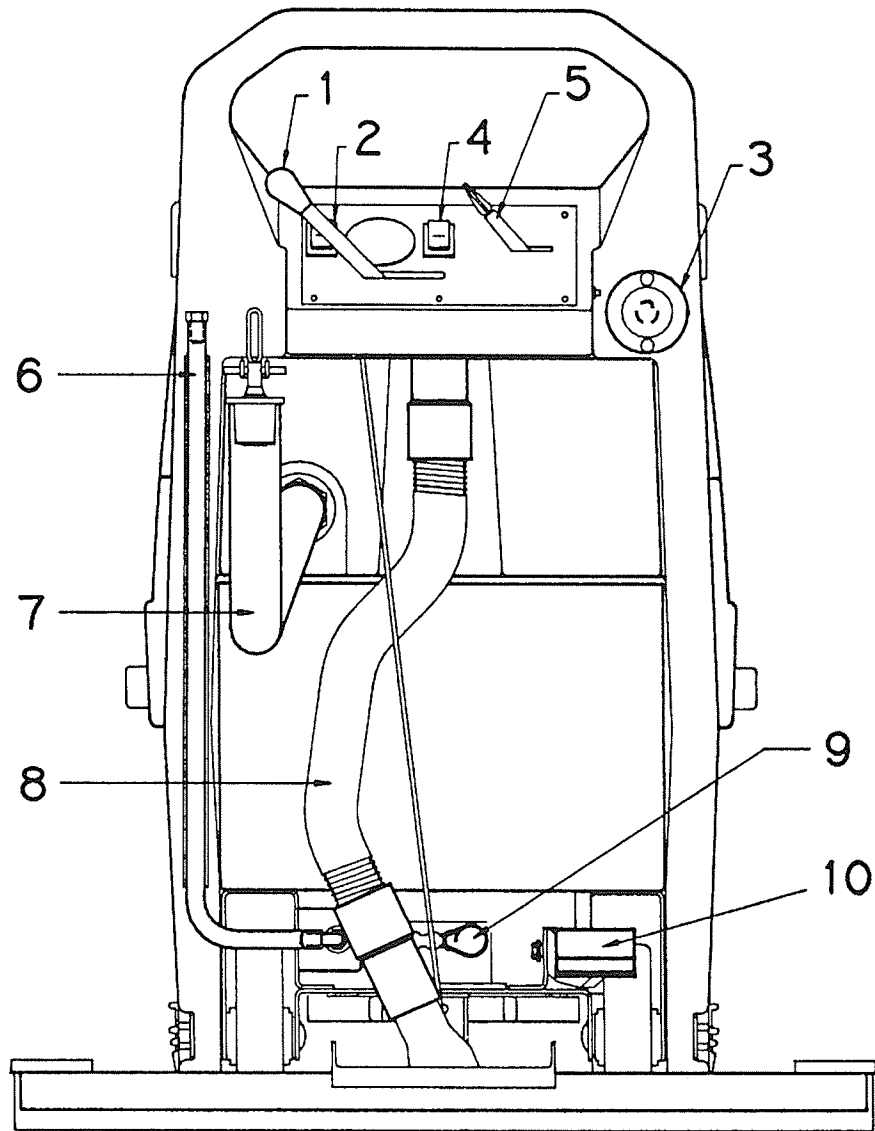

- | | |
|---------------------------|--|
| 1. Squeegee left lever | 6. Drain hose for clean solution tank |
| 2. Vacuum switch | 7. Drain hose for recovery tank |
| 3. Power cable hook-up | 8. Vacuum recovery hose |
| 4. Brush switch | 9. Power assist control |
| 5. Solution control lever | 10. Foot pedal for lower/raising brush |

BRUSH REMOVAL

Unplug machine.

Empty solution and recovery tanks.

Remove squeegee assembly.

Lower brush.

Tilt machine as shown (figure 3) until machine rests on foot pedal.

Brush has a snap-on push off clutch plate. Pushing brush away from the machine from the side, will release brush assembly.

To install: Hold brush in the center and snap on to drive hub.

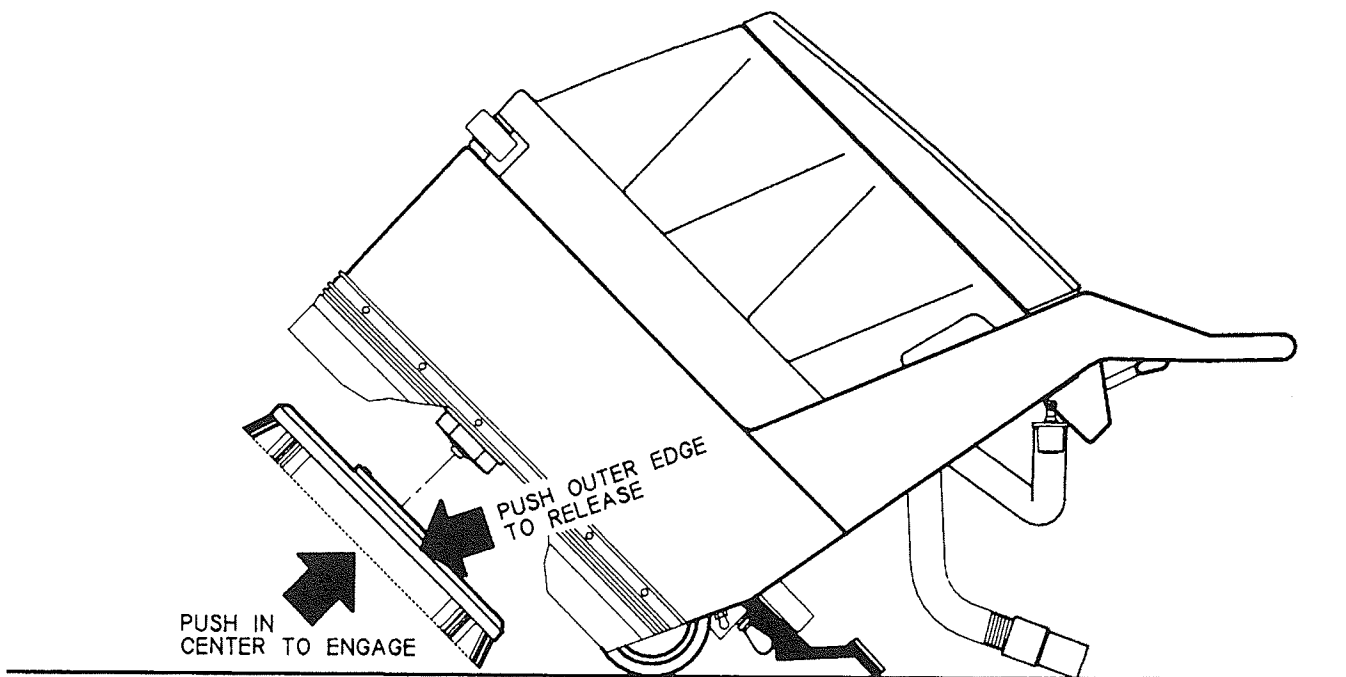

Figure 3

OPERATING INSTRUCTIONS

1. **Filling:** Fill the solution tank with the desired amount of water and add liquid cleaning solution to the proper dilution ratio. **DO NOT USE** powdered cleaning chemicals. Powders are unlikely to dissolve thoroughly, resulting in clogging the in-line solution filter. This can reduce or stop water flow to the brush.
2. Lower brush assembly.
 - To lower the brush, first push the pedal slightly towards the center of the machine (unlock it), then release it slowly.
 - To lift the brush, press the pedal down until lift mechanism engages.
3. Turn on brush switch.
4. Adjust solution control feed lever.
5. Turn on vacuum switch.
6. Lower squeegee assembly.

After Use:

1. Turn off solution feed.
2. Switch off brush and raise.
3. Raise squeegee assembly.
4. Turn off vacuum motor.

Solution and recovery tanks should be emptied after every use.

MAINTENANCE:

- | | |
|---------|--|
| Daily | <ol style="list-style-type: none">1. Clean float assembly & squeegee blades.2. Wipe down outside of machine with damp cloth. |
| Monthly | <ol style="list-style-type: none">1. Check wear on squeegee blades.2. Grease rear wheels.3. Grease pivot points on brush motor assembly. |

Every 500 hours check condition of carbon brushes on vacuum motor and brush drive motor.

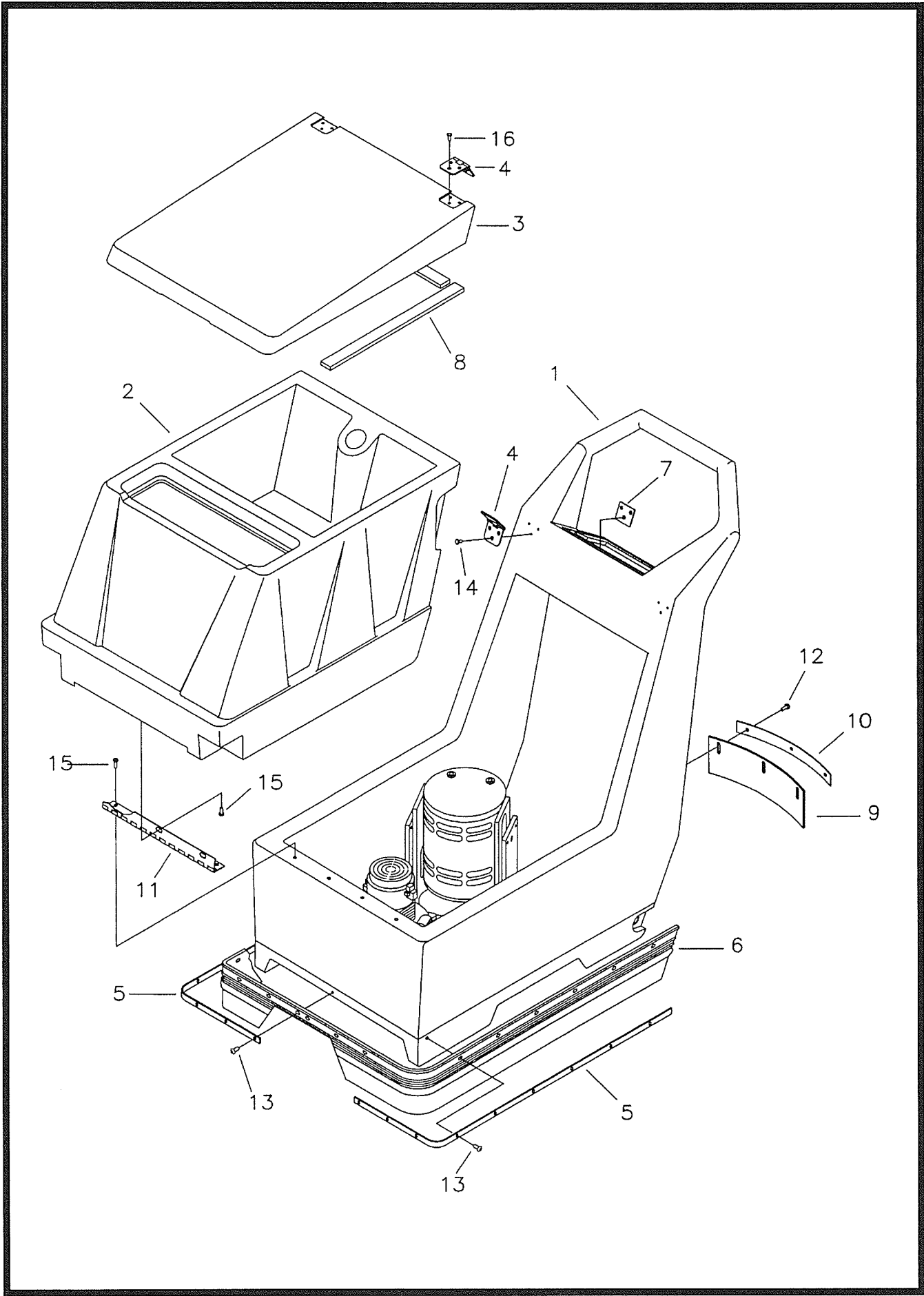

Parts List

Item	Part No.	Qty.	Description
1	430000MCH	1	Base Assy. 17 B/E Machined
2	430001MCH	1	170 Sol./Recovery Tank Assy.
3	430002	1	Cover Poly 170 Burgundy
4	430044	2	Hinge Lid 17 B/E
5	430046	2	Side Skirt Retainer 17
6	430049	1	Splash Skirt 17 B/E
7	430126	2	Hinge Backing Plate
8	430136	1	Gasket Seal Kit (4)
9	430141	1	Splash Skirt 170
10	430142	1	Mounting Bracket
11	450021	1	Hinge
12	711104	3	SCR-ST-A#10 x .50
13	711161	18	SCR-Hi/Lo #10 x 3/4 PL
14	712536	6	SCR-MC 10-24 x .62 SS
15	712560	6	SCR-MC 1/4-20 x .50 SS
16	712822	6	SCR-THMS 10-24 x .50 STPL

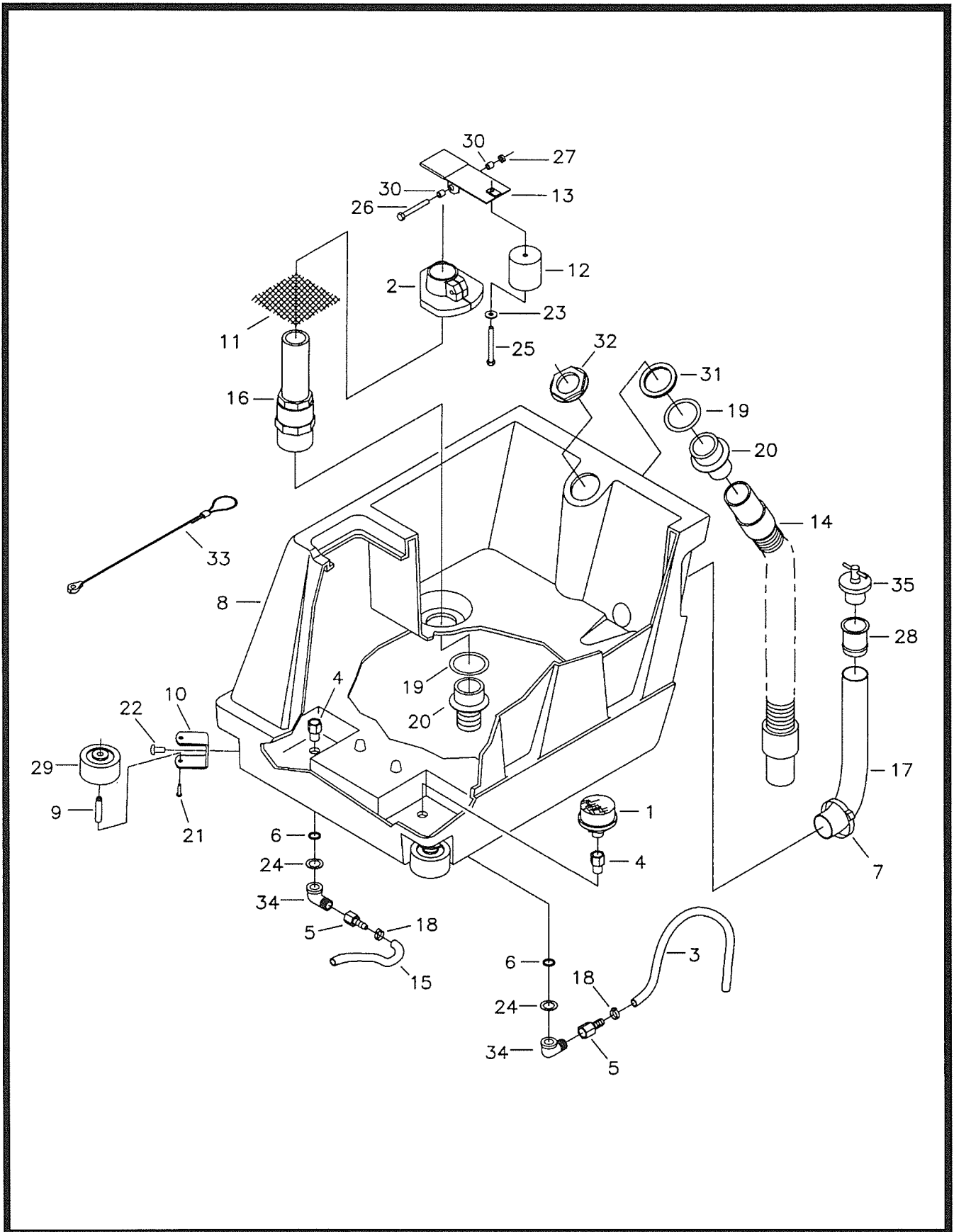

Parts List

Item	Part No.	Qty.	Description
1	130118	1	Solution Strainer
2	200173	1	Float Housing
3	210401	1	Solution Hose
4	210409	2	Fitting Brass 3/8 MPT 3/8 FPT
5	210410	2	Fitting Brass 3/8 FPT 3/8 Barb
6	210414	2	O-Ring 2-113
7	260203	1	Hose Clamp
8	430001MCH	1	170 Sol./Recovery Tank
9	430037	2	Bumper Wheel Axle
10	430038	2	U Bracket Wheel Mount
11	430050	1	Filter Screen 4 x 4
12	430089	1	Float 17B
13	430090	1	Float Valve Weldment
14	430098	1	Vac Recovery Hose 22 C/L
15	430116	1	Hose 3/8 Nylo 34"
16	430121	1	Standpipe Assy. 170/175
17	430199	1	Hose White Wireloc 24"
18	450076	1	Crimp Clamp SS 185R
19	450081	2	WSR SS 1.908 x 2.41 x .03
20	450083	2	Insert Fitting
21	710353	2	SCR-MC 10-32 x .37 STPL
22	710985	2	SCR-SC 3/8-16 x .62
23	711504	1	WSR-Flat 1/4 ID SS
24	711513	2	WF .689 x 1.06 x .029 SS
25	712092	1	SCR Nylon 1/4-20 x 2.5
26	712568	1	SCR-MC 1/4-20 x 2.25 SS
27	712667	1	Nut-Hex 1/4-20 SS Nyloc
28	760343	1	Tjube Hose 24/32B
29	762331	2	Wheel, 2.5D x 1.28W x .38ID
30	762384	2	Bushing SS .277 x .375 x .37
31	828970	1	WSR Neop 1.87 x 2.4 x .125
32	828971	1	Nut 1 1/2 Pipe Thread
33	829559	1	Cable Assy. 170/175
34	830062	2	Fitting Brass 90 3/8 MPT
35	833316	1	Drain Plug

27A 740429 VAC MTR (220 V) USED ON 115 V MODEL
 27B 741030 VAC MTR 240 V SINGLE STAGE EXPORT

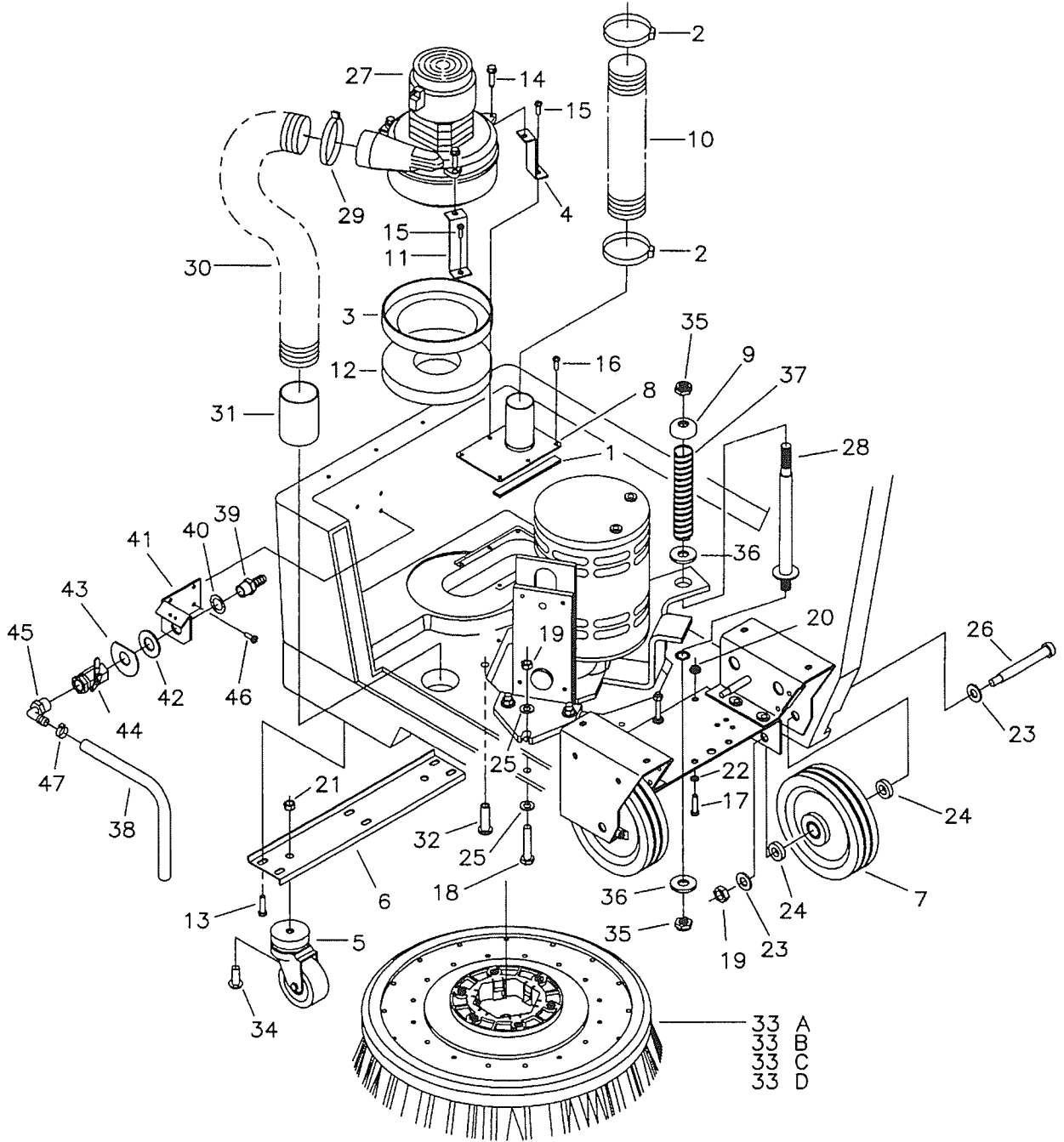

Parts List

Item	Part No.	Qty.	Description
1	250041	1	Seal, Rubber
2	831001	2	Crimp Clamp 440R
3	290017	1	Molded Vac Mtr. Gasket
4	430018	2	Z Bracket
5	430029	2	Caster
6	430042	1	Caster Mounting Bracket
7	430138-1	2	Wheel 6"
8	430069	1	Vacuum Manifold Assembly
9	828264	1	Spring Washer Cup
10	430099	1	Vacuum Hose
11	450038	1	Z Bracket
12	460019	1	Gasket 3.75 x 5.75 x .75
13	710178	6	SCR-MC 1/4 - 20 x .50 STPL
14	712129	3	SCR-TR 1/4-20 x 1.00 HWH
15	711106	3	SCR-ST-A 10 x .75 PL
16	711161	5	SCR Hi/Lo #10 x 3/4 PL
17	711210	3	BLT-HH 1/4 - 20 x 1.25 STPL
18	711243	6	BLT-HH 3/8 - 16 x 1.5 STPL
19	711380	8	Nut-Nyloc 3/8 - 16
20	711425	3	Nut-Flanged Wizz 1/4 - 20
21	711439	2	Nut-Flanged Wizz 3/8 - 16
22	711506	3	WSR-Flat 5/16 STPL
23	711509	4	WSR-Flat 1/2
24	430149	4	Bushing .531 x 1 x .25 SS
25	711515	6	WSR-Flat .406 x .812 x .062
26	712090	2	Shoulder Blt. 1/2 x 3.5
27A	740429	1	Vac Motor 220V
27B	741030	1	Vac Motor 240V
28	210083	1	Adjusting Rod Weldment
29	829067	1	Crimp Clamp 560R
30	762398	1	Hose, Rubber Flex 2 x 13
31	801013	1	Sleeve, Hose
32	832136	1	Nylon Sleeve Sol. Feed
33A	430034	1	Nylon Brush
33B	430108	1	Pad Driver
33C	430108	1	Poly Grit Brush
33D	430108	1	Strato Grit Brush
34	710986	2	SCR-SC 3/8 - 16 x 1.00
35	364-816	1	Nut-Nyloc 1/2
36	711510	2	Washer
37	828301	1	Spring
38	210401	2	Solution Hose
39	342430	1	Fitting Brass 3/8 MPT 3/8 Barb
40	711513	1	WSR-Flat .689 x 1.06 x .029
41	210370	1	Solution Valve Bracket
42	828975	1	WSR-Neo .75 x 1.50 x .09
43	829463	1	WSR-Flat .75 x 2.00 x .05
44	809413MCH	1	Solution Valve
45	450040	1	Elbow 3/8 MPT x 3/8 Barb
46	711106	3	SCR-ST-A 10 x .75 PL
47	450076	1	Crimp Clamp SS 185R

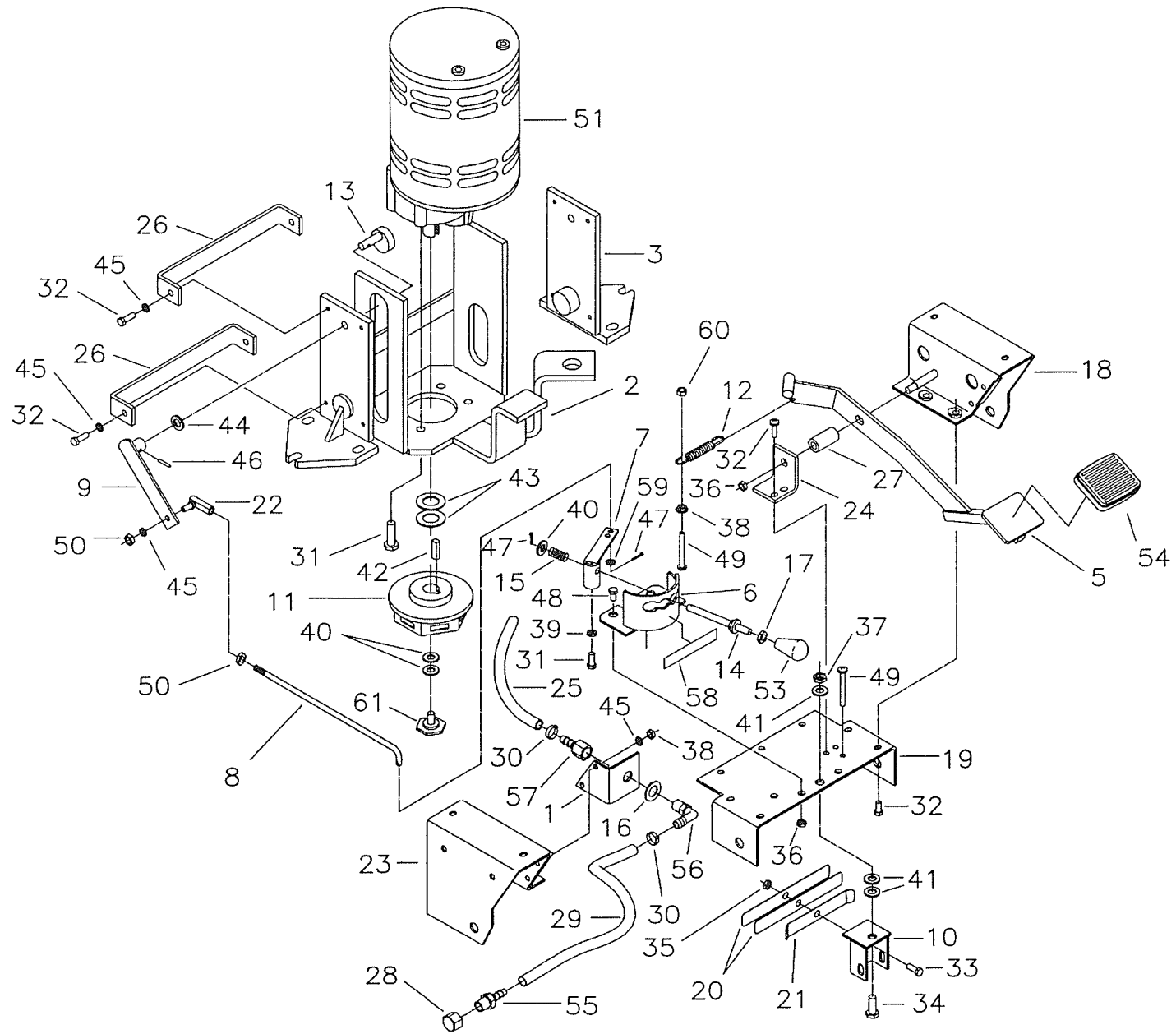

Parts List

Part No.	Qty.	Description	Item	Part No.	Qty.	Description	
1	100000	1	Mounting Bkt. Quick Disc.	32	711202	10	BLT-HH 1/4 - 20 x .50 STPL
2	430003	1	Motor Mount Weldment	33	711227	1	BLT-HH 5/16 - 18 x .62
3	430009	2	Motor Brkt. Weldment	34	711246	1	BLT-HH 3/8 - 16 x .87 STPL
4				35	711374	1	Nut-Nyloc 5/16 - 18
5	430014	1	Motor Lift Weldment	36	711379	3	Nut-Flanged Wizz 5/16 - 18
6	430019	1	Speed Control Weldment	37	711380	1	Nut-Nyloc 3/8 - 16
7	430022	1	Control Pivot Weldment	38	711425	4	Nut-Flanged Wizz 1/4 - 20
8	430025	1	Speed Control Rod	39	711439	1	Nut-Flanged Wizz 3/8 - 16
9	430026	1	Speed Control Weldment	40	711506	3	WSR-Flat 5/16 STPL
10	430030	1	Squeegee Mount Weldment	41	711515	2	WSR-Flat .44 x .87 x .07
11	430035	1	Drive Hub	42	320268	1	Key 1/4 x 5/16 x 1
12	430051	1	Return Spring	43	711517	3	WSR-Flat .77 x 1.37 x .03
13	430054	1	Pivot Cam 17 B/E	44	711523	2	WSR-Wave .37 x .68 x .02
14	430055	1	Threaded Connecting Rod	45	711544	9	WSR-Helical 1/4
15	430056	1	Compression Spring	46	711615	1	Rollpin .12 x .75
16	711579	1	WSR-Flat .56 x 1.00	47	711803	2	Cotter Pin .06 x .75
17	711420	1	Nut-Hex Jam 5/16-18 STPL	48	712042	3	Drive Hub Retainer Bolt
18	430064	1	Wheel Mount U Strut Right	49	712569	3	Bolt-WSR HH 5/16-18 x .62
19	430065	1	Mtg. Plate Wheel Carriage	50	712666	2	Nut-Hex Jam 1/4 - 28 SS
20	430066	3	Squeegee Return Spring L	51	740428	1	Gearmotor 115V
21	430067	1	Squeegee Return Spring S	51A	740432	1	Gearmotor 230V
22	430080	1	Balljoint (SP1002)	53	760592	2	Knob Oval Tapered
23	430081	1	Wheel Mount U Strut Left	54	210142	1	Pedal Pad
24	430088	1	L Bkt. Motor Lift	55	828952	1	Fitting 1/4 MPT x 3/8 Barb
25	430116	1	Hose 3/8 Nylo x 34"	56	833325	1	Fitting Nylon 90° 1/4 MPT
26	430106	2	Stabilizer Bar Lower	57	833473	1	Fitting Brass 1/4 FPTx 3/8 Barb
27	430113	1	Hose 3/8 x 1.375	58	715136	1	Decal Diecut Speed Control
28	430114	1	Nylon Cap 1/4 FPT HC4	59	711505	3	WSR-Flat 1/4
29	430118	1	Clear Dump Hose C/L 22"	60	711373	1	Nut-Nyloc 1/4-20
30	450076	2	Crimp Clamp SS 185R	61	210066	1	Drive Hub Retainer Bolt
31	710986	5	SCR-SC 3/8 - 16 x 1.00 STPL				

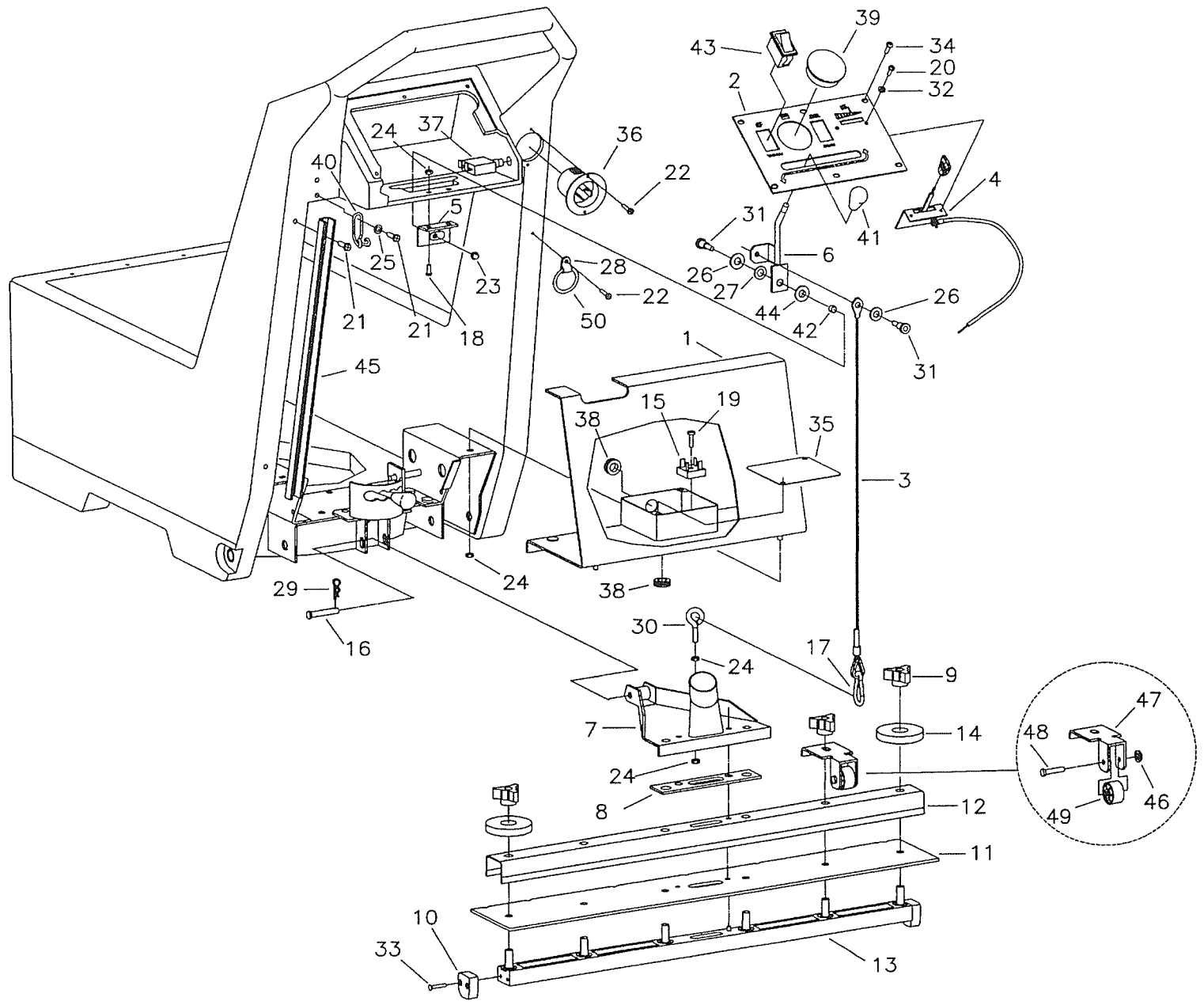

Parts List

Item	Part No.	Qty.	Description	Item	Part No.	Qty.	Description
1	430123	1	Rear Cover	28	250038	1	Retainer Clip
2	430039SP	1	Dashboard 170 Screen Printed	29	711808	1	Cotter Pin-Hair #13
2A	430039CESP	1	Dashboard 170CE Screen Printed	30	712026	1	Wire Eye Bolt 1/4 - 20
3	430052	1	Squeegee Lift Cable Assy.	31	712041	2	Blt-Sder 1/4 - 20 x .44 x .37
4	430053	1	Solution Control Cable A	32	712320	2	WSR Nylon .22 x .45 x .04
5	430059	1	Squeegee Lift Brkt. Assy.	33	712517	4	SCR-MC #8-32 x 1 SS FH
6	430060	1	Squeegee Lift Arm Assy.	34	712822	6	SCR-THMS 10 - 24 x .50 STPL
7	430070	1	Squeegee Mount Assy.	35	805634	1	Box Cover
8	430073	1	Gasket Diecut PS Back	35A	715098CE	1	Decal Dashboard 170CE
9	430074	6	Adjusting Nut 17 B/E	36	830540	1	Twist Loc Receptacle
10	430076	2	Nylon Squeegee Insert	37	740220	1	Circuit Breaker 20 amp (115V)
11	11-145	1	Squeegee Gum Rubber	37B	762299	2	Circuit Breaker 9 amp (120V)
12	430078	1	U Profile	38	762299	2	Grommet .50 x .09 x .75
13	430079	1	Casting Squeegee Assy.	39	833823	1	Dome Plug 2"
14	430085	2	Squeegee Bumper Wheel	40	760286	1	Wire Formed Hook
15	740202	1	Rectifier Bridge 50A 600V	41	760592	1	Knob Oval Tapered
16	430105	1	Clevis Pin .312 x 1.75	42	762058	1	Spacer .319 x .375 x .250
17	430103	1	Spring Hook	43	809754	2	Switch Rocker
18	710180	2	SCR-MC 1/4 - 20 x .75 STPL	43A	740711CE	2	Switch w/Splashguard
19	711126	1	SCR-ST-B 10 x .75	44	829014	1	Flanged Bushing
20	711124	2	SCR-ST-B #10 x .37 NI	45	430120	1	U Channel 170 18"
21	711161	6	SCR-Hi/Lo #10 x 3/4 PL	46	370074	2	Hubcap
22	711128	3	SCR-ST-B Hi/Lo 8 x .62 PL	47	832973	2	Wheel Bracket
23	711352	1	Nut-Acorn 1/4 - 20 ST NI	48	832974	2	Clevis Pin 1/4 x 1 3/8
24	711425	6	Nut-Flanged Wizz 1/4 - 20	49	370031	2	Wheel 1.5 Molded
25	711503	2	WSR-Flat #10	50	833827	1	O-Ring 1.25 ID x .187
26	711506	2	WSR-Flat 5/16 STPL	51	830292	1	Cord Assy. 14/3 75' (115V)
27	711523	1	WSR-Wave .37 x .68 x .02	51A	740477	1	Cord Assy. (230V)

WIRING DIAGRAM, 115V, STANDARD 230V

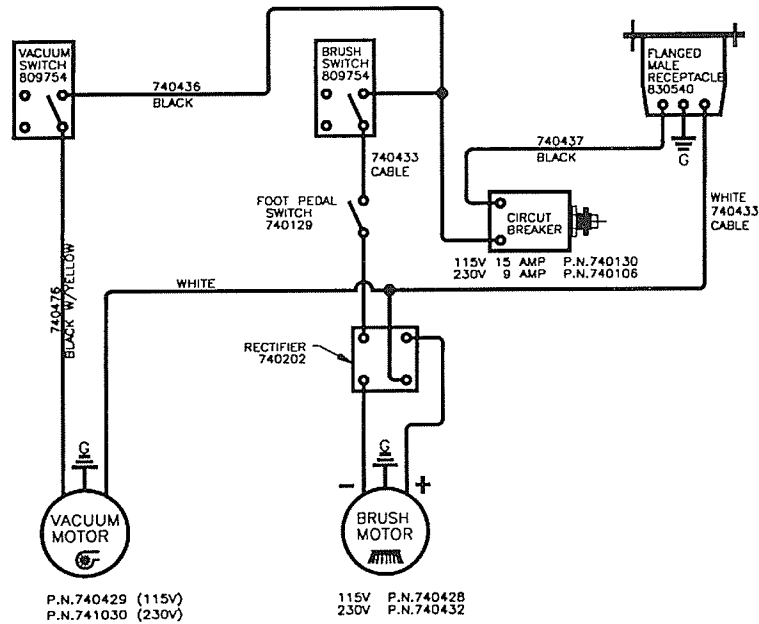

WIRING DIAGRAM, 230V CE

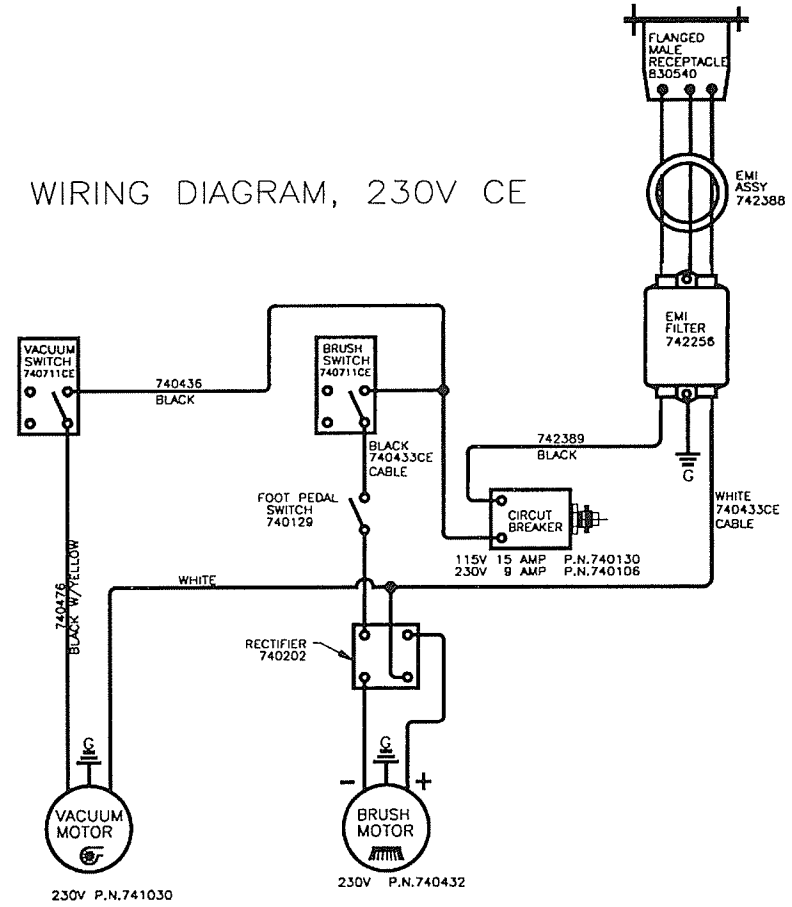

LIMITED WARRANTY

Minuteman International, Inc. warrants to the original purchaser/user that this product is free from defects in workmanship and materials under normal use and service for a period of three years from date of purchase. In addition, Minuteman International, Inc. will, at its option, honor labor warranty claims for the first 12 months from date of sale, provided such claims are submitted through and approved by factory authorized repair stations. Minuteman International, Inc. will, at its option, repair or replace without charge, except for transportation costs, parts that fail under normal use and service when operated and maintained in accordance with the applicable operation and instruction manuals.

This warranty does not apply to normal wear, or to items whose life is dependent on their use and care, such as belts, cords, switches, hoses, rubber parts, electrical motor components or adjustments. Parts not manufactured by Minuteman International, Inc. such as engines, batteries, battery chargers, hydraulic pumps, and tires are covered by and subject to the warranties and/or guarantees of their manufacturers. Please contact Minuteman International, Inc. for procedures in warranty claims against these manufacturers.

Special warning to purchaser — Use of replacement filters and/or prefilters not manufactured by Minuteman International, Inc. or its designated licensees, will void all warranties expressed or implied.

A potential health hazard exists without exact original equipment replacement.

All warranted items become the sole property of Minuteman International, Inc. or its original manufacturer, whichever the case may be.

Minuteman International, Inc. disclaims any implied warranty, including the warranty of merchantability and the warranty of fitness for a particular purpose. Minuteman International, Inc. assumes no responsibility for any special, incidental or consequential damages.

This limited warranty is applicable only in the U.S.A. and Canada, and is extended only to the original user/purchaser of this product. Customers outside the U.S.A. and Canada should contact their local distributor for export warranty policies. Minuteman International, Inc. is not responsible for costs or repairs performed by persons other than those specifically authorized by Minuteman International, Inc. This warranty does not apply to damage from transportation, alterations by unauthorized persons, misuse or abuse of the equipment, use of non-compatible chemicals, or damage to property, or loss of income due to malfunctions of the product.

If a difficulty develops with this machine, you should contact the dealer from whom it was purchased.

This warranty gives you specific legal rights, and you may have other rights which vary from state to state. Some states do not allow the exclusion or limitation of special, incidental or consequential damages, or limitations on how long an implied warranty lasts, so the above exclusions and limitations may not apply to you.

Minuteman[®]

World Headquarters

Minuteman International, Inc.
111 South Rohlwing Road
Addison, Illinois 60101

Minuteman Canada, Inc.

2210 Drew Road
Mississauga, Ontario
L5S 1B1

(630) 627-6900
FAX (630) 627-1130

(905) 673-3222
FAX (905) 673-5161

983211
Printed in U.S.A.