



Electronic Service Manuals

This electronic document is provided as a service to our customers. We do not create the contents of the information contained in this document. Should you have detailed questions pertaining to the information contained in this document, you may contact Michco, or the manufacturer which provided the original information in this electronic deliverable. Michco's only part in this electronic deliverable was the electronic assembly process. By providing this manual on line we are not guaranteeing parts availability.

You may contact Michco through the following methods:

Phone (517) 484-9312 or (800) 331-3339

2011 N. High St. -- Lansing, Michigan -- 48906

Fax: (517) 484-9836

Email: CustServe@Michco.com

Web site: www.Michco.Com

Parts Web site: www.FloorMachineParts.Com

Order Parts on Line at:

www.FloorMachineParts.Com

Directly to Parts & Service:

By Email: **Shop@Michco.com**

By Fax: (517) 702-2041

By Voice: Use numbers above.

Serving the Cleaning Industry Since 1922

Notice: All copyrighted material remains property of original owners, all trademarks are property of respective owners. Manuals are subject to Manufacturer's reproduction limitations. Originals or reproductions were provided by manufacturers through a request. We make no warranty as to the correctness of information provided in this document and you assume all risk. By placing these manuals on line we are not declaring our corporation to be an manufacturer authorized dealer or provider, please check our web site for authorized manufacturers we represent.

Razor 17B – 20B – 20BT

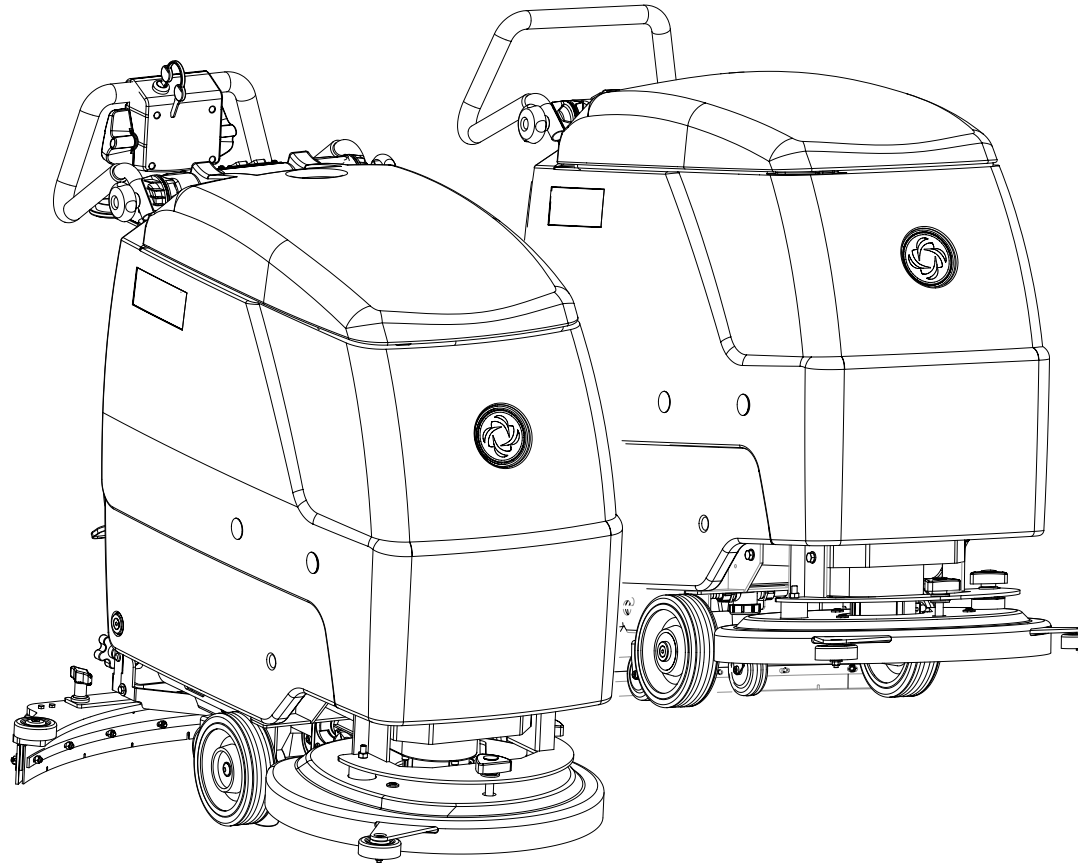

PARTS LIST

KENT/Euroclean MODELS:

908 7010 020 – 908 7011 020 – 908 7025 020



KENT
Euroclean

Working For A Cleaner World

L08812947(4)2006-12

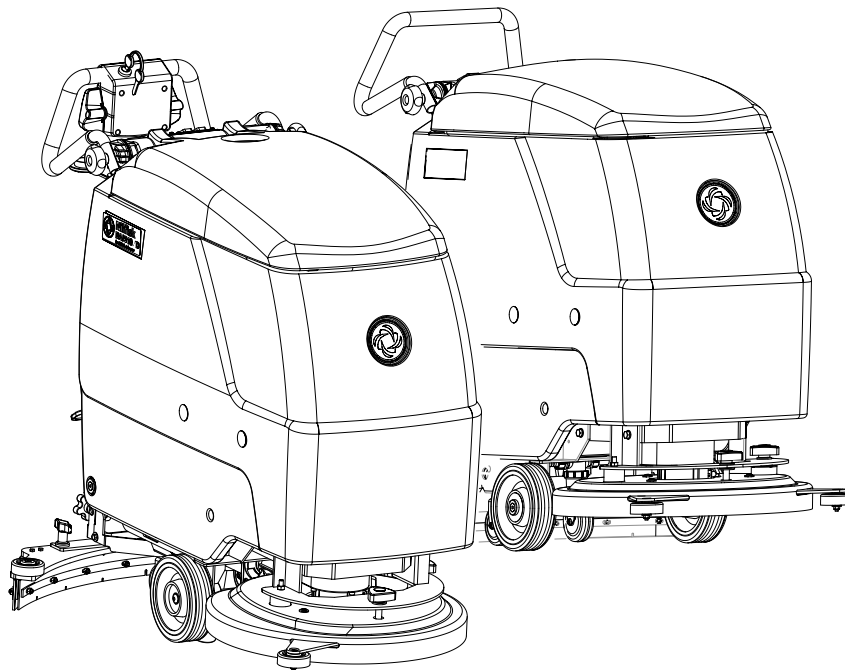
**DESCRIPTION****PLAN**

GENERAL VIEW	2 - 3
TANK SYSTEM	4 - 7
HANDLE ASSEMBLY	8 - 9
CHASSIS SYSTEM	10 - 11
CHASSIS SYSTEM RAZOR 20BT	12 - 13
SOLUTION SYSTEM	14 - 15
SOLUTION SYSTEM	16 - 17
SOLUTION SYSTEM RAZOR 20BT	18 - 19
SQUEEGEE ASSEMBLY	20 - 21
BRUSH SYSTEM RAZOR 17B	22 - 23
BRUSH SYSTEM RAZOR 20B	24 - 25
BRUSH SYSTEM RAZOR 20BT OFF SET	26 - 27
CONTROL PANEL SYSTEM	28 - 29
WIRING SYSTEM	30 - 31
WIRING SYSTEM RAZOR 20BT	32 - 33
WIRING DIAGRAM	34
WIRING DIAGRAM RAZOR 20BT	35
RECOMMENDED SPARE PARTS	36

WHEN ORDERING PARTS

- * Use the 8,9 or 10 digit part numbers from the "Ref. No." columns in this parts list.
- * Specify the model and serial number of the machine.
- * Use the space below to record the model and the serial number for future reference.

Model _____ Serial No. _____

**= *Optional*

= *New Item no.*

[] = *Not shown*

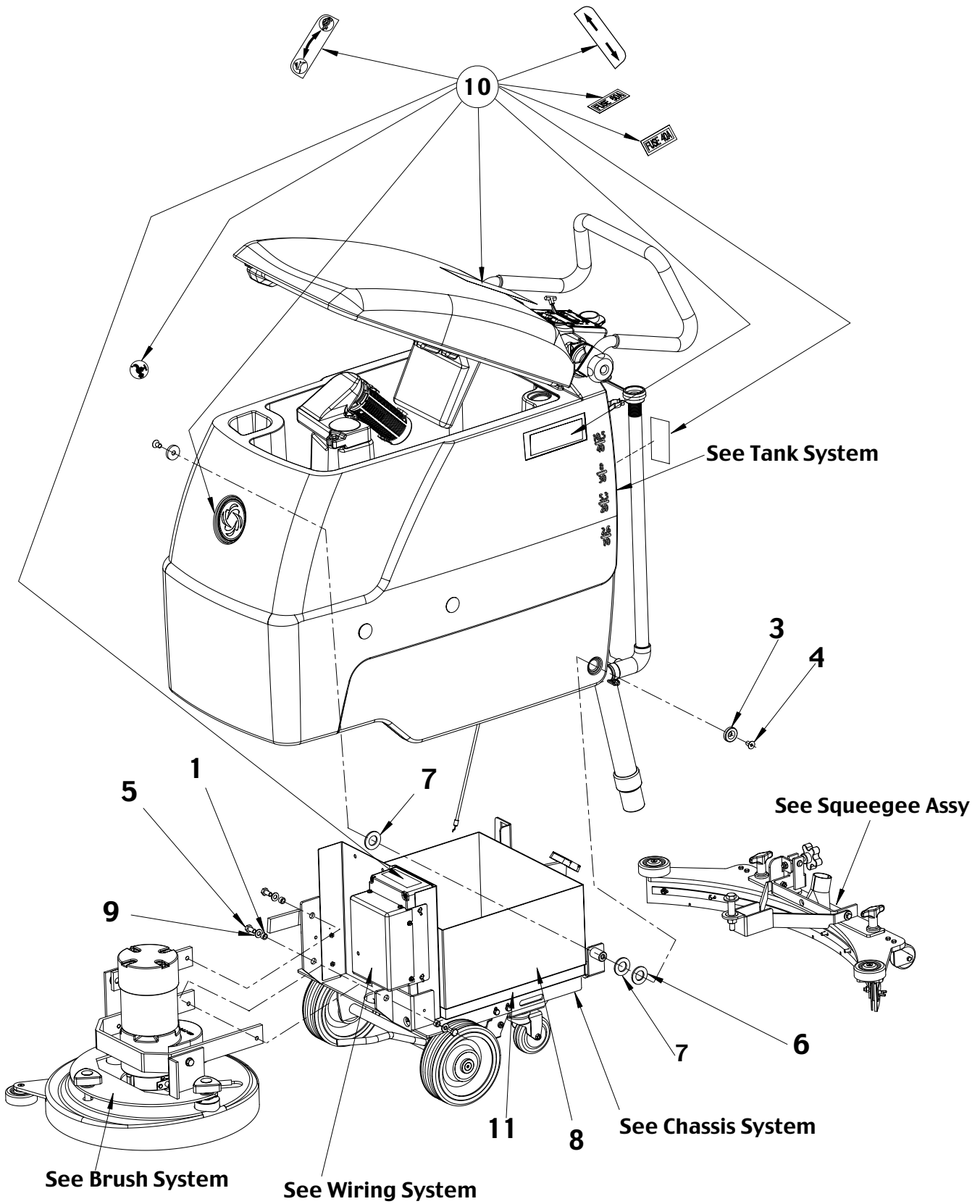

2003-09	GENERAL VIEW		
	RAZOR 17B/ RAZOR 20B/ RAZOR 20BT		3

Item no.	Ref. No.	Qty	Description
1	xxxxxxx	3	Spacer (General Hardware Kit)
3	xxxxxxx	2	Spacer for tank (General Hardware Kit)
4	xxxxxxx	2	Screw M8x14 (General Hardware Kit)
5	xxxxxxx	3	Screw hex hd M8x16 (General Hardware Kit)
6	xxxxxxx	1	Washer flat nylon (General Hardware Kit)
7	xxxxxxx	1	Washer flat nylon (General Hardware Kit)
8#	L08812758	1	Battery container
9	xxxxxxx	3	Washer flat M8x17(General Hardware Kit)
10#	L08603908	1	Kit decals Kent Razor 17B
10#	L08603909	1	Kit decals Kent Razor 20B
11#	L08603930	1	Weight
[12]#	L08603955	1	General Hardware Kit

2003-09	TANK SYSTEM			
	RAZOR 17B/ RAZOR 20B/ RAZOR 20BT			5

Item no.	Ref. No.	Qty	Description
1#	L08812887	2	Carbon brush (c)
1	909 5074 000	1	Carbon brush set (d)
2#	L08812462	3	Buffer
3#	L08812082	1	Hose guide
4#	L08603868	1	Closure clean water hose
5	xxxxxxx	1	Clamp (Tank System Hardware Kit)
6	xxxxxxx	1	Clamp (Tank System Hardware Kit)
8#	L08603836	1	Gasket, tank cover
9#	L08603858	1	Kit acoustic cover cpl
10#	L08603970	1	Squeegee lift.lever kit
11#	L08812901	1	Handle bar
12#	L08603888	1	Kit vacuum motor w/ connector TSB IT 2003-005 (serial no.1665510)
13#	L08603860	1	Handle adjuster kit
14#	L08603951	1	Hose fresh water
15#	L08812977	1	Acoustic insulation
16#	L08812869	1	Drain hose
17	xxxxxxx	1	Clamp (Tank System Hardware Kit)
18#	L08812873	1	Solution drain hose complete
19	xxxxxxx	1	Shaft retainer ø8 (Tank System Hardware Kit)
20#	L08812365	4	Cap, tank locking
21#	L08812468	3	Spacer
22#	L08603952	1	Elbow
23	xxxxxxx	3	Clamp (Tank System Hardware Kit)
24	xxxxxxx	3	Screw M6x25 (Tank System Hardware Kit)
25	xxxxxxx	4	Screw 4x14 thd forming SS (Tank System Hardware Kit)
26	xxxxxxx	1	Clamp ø25 SS (Tank System Hardware Kit)
27	xxxxxxx	1	Clamp ø50 SS (Tank System Hardware Kit)
28#	L08602410	1	Gasket suction motor
29#	L08812968	1	Gasket
30#	L08812874	1	Kit elbow
31	xxxxxxx	3	Screw (Tank System Hardware Kit)
32#	L08812991	1	Tank lid cpl. with gasket
33#	L08812990	1	Tank
34#	L08812318	1	Acoustic insulation
35#	L08812930	1	Suction Hose
36	145 8589 000	1	Acoustic ins. hose
37	xxxxxxx	4	Washer, flat (Tank System Hardware Kit)
38	xxxxxxx	3	Washer, flat (Tank System Hardware Kit)
39	xxxxxxx	2	Washer, flat (Tank System Hardware Kit)
40	xxxxxxx	2	Screw M5x12 SS (Tank System Hardware Kit)
41	145 1712 000	1	Flexible hose
42#	L08812259	2	Float cage
43#	L08812373	1	Floating ball
44#	L08812992	1	Support, float cage
45	xxxxxxx	2	Screw pan hd phil 6x25 SS (Tank System Hardware Kit)
46	xxxxxxx	1	Clamp (Tank System Hardware Kit)
47	909 5042 000	1	Acoustic insulation
48	xxxxxxx	2	Screw 5x20 (Tank System Hardware Kit)
49	xxxxxxx	1	Screw, tank fixing (Tank System Hardware Kit)

(c) L08812887 for Fise vacuum motor L08602437 (d) 909 5074 000 for Ametek vacuum motor 909 5021 000

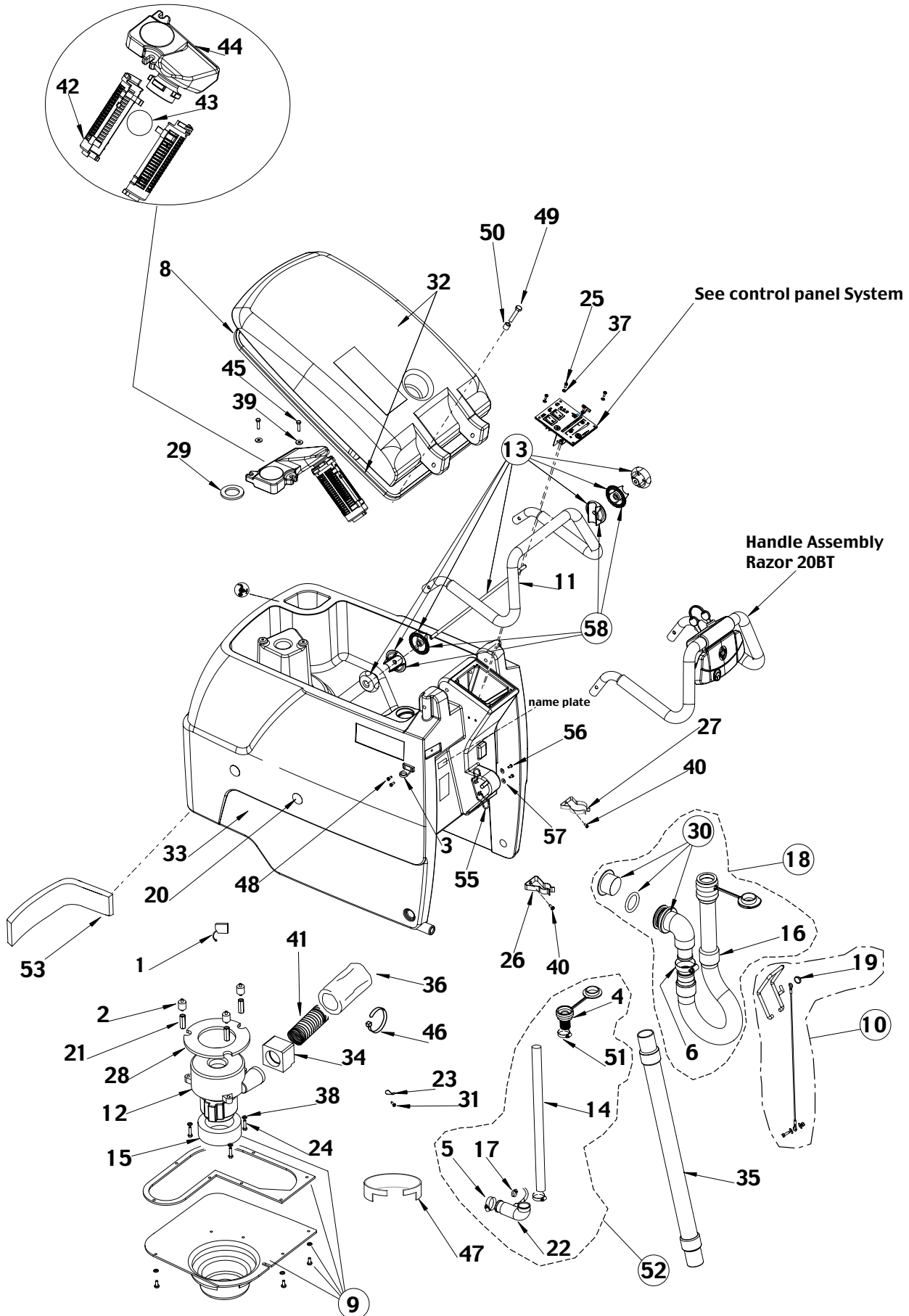

2003-09	TANK SYSTEM		
	RAZOR 17B/ RAZOR 20B/ RAZOR 20BT		7

Item no.	Ref. No.	Qty	Description
50#	L08812449	1	Spacer
51#	L08603916	2	Clamp
52#	L08603969	1	Kit fresh water hose
53#	L08603910	1	Insulation gasket
[54]#	L08603956	1	Tank System Hardware Kit
55	909 5149 000	1	Battery cable support
56	909 5009 000	2	Screw cyl hd M5x12
57	145 8280 000	2	Washer flat 5x15 SS
58	909 5099 000	1	Ratchet handle adjuster kit

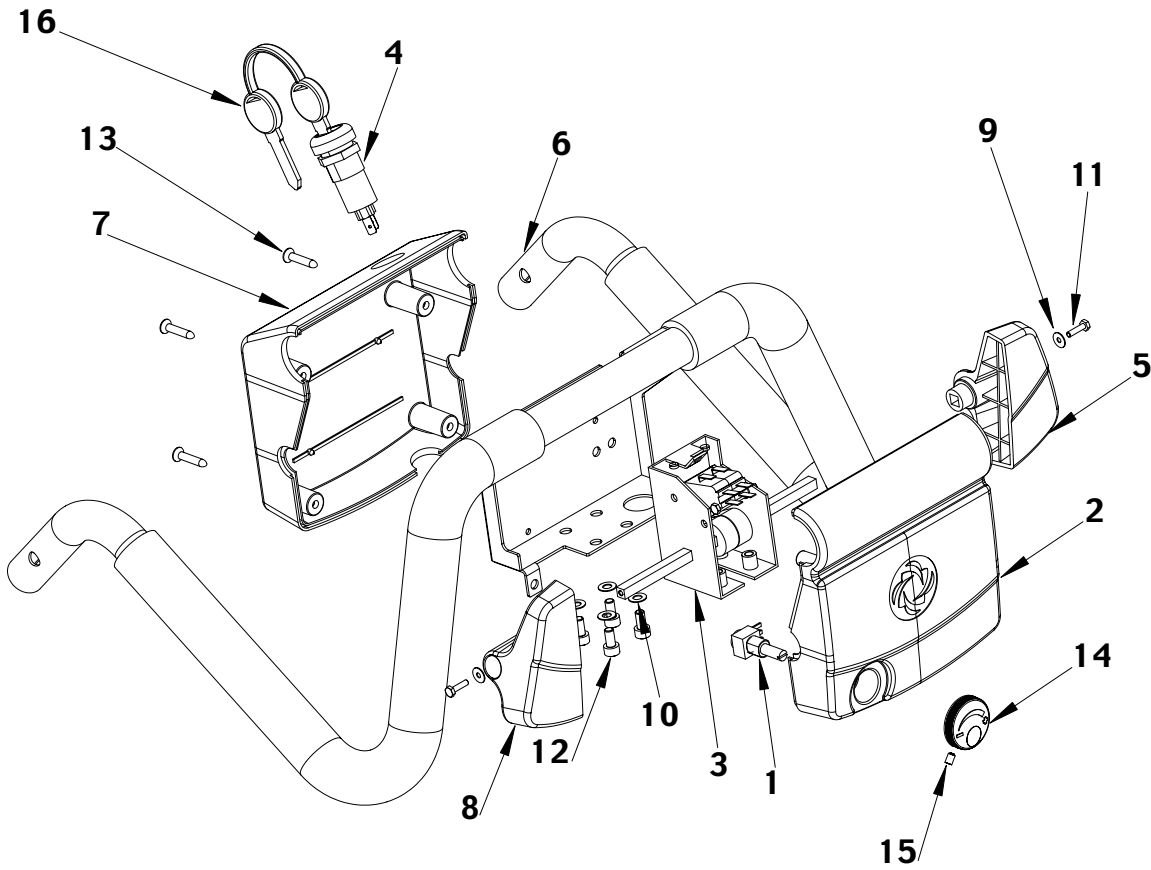

2003-09	HANDLE ASSEMBLY		
	RAZOR 20BT		9

Item no.	Ref. No.	Qty	Description
1	909 5162 000	1	Harness, potentiometer
2	909 5118 000	1	Switch housing front (Handle System Hardware kit)
3	909 5114 000	1	Drive/motor microswitch
4	145 0372 000	1	Key switch
5	909 5119 000	1	Lever right (Handle System Hardware kit)
6	909 5113 000	1	Handle bar
7	909 5117 000	1	Switch housing rear (Handle System Hardware kit)
8	909 5120 000	1	Lever left (Handle System Hardware kit)
9#	L08812097	2	Washer flat 3x9 SS (Handle System Hardware kit)
10#	L08040400	4	Washer flat 5x10 (Handle System Hardware kit)
11	145 9117 000	2	Screw hex hd M3x12 (Handle System Hardware kit)
12	145 1238 000	4	Screw hex hd M5x10 (Handle System Hardware kit)
13	145 5871 000	4	Screw 4,2x23 thd form (Handle System Hardware kit)
14	909 5116 000	1	Potentiometer knob (Handle System Hardware kit)
15	146 0621 000	1	Dowel M4x6 (Handle System Hardware kit)
16	146 0806 000	1	Key (2 pcs)
17	909 5281 000	1	Handle System Hardware kit (2,5,7,8,9,10,11,12,13,14,15)

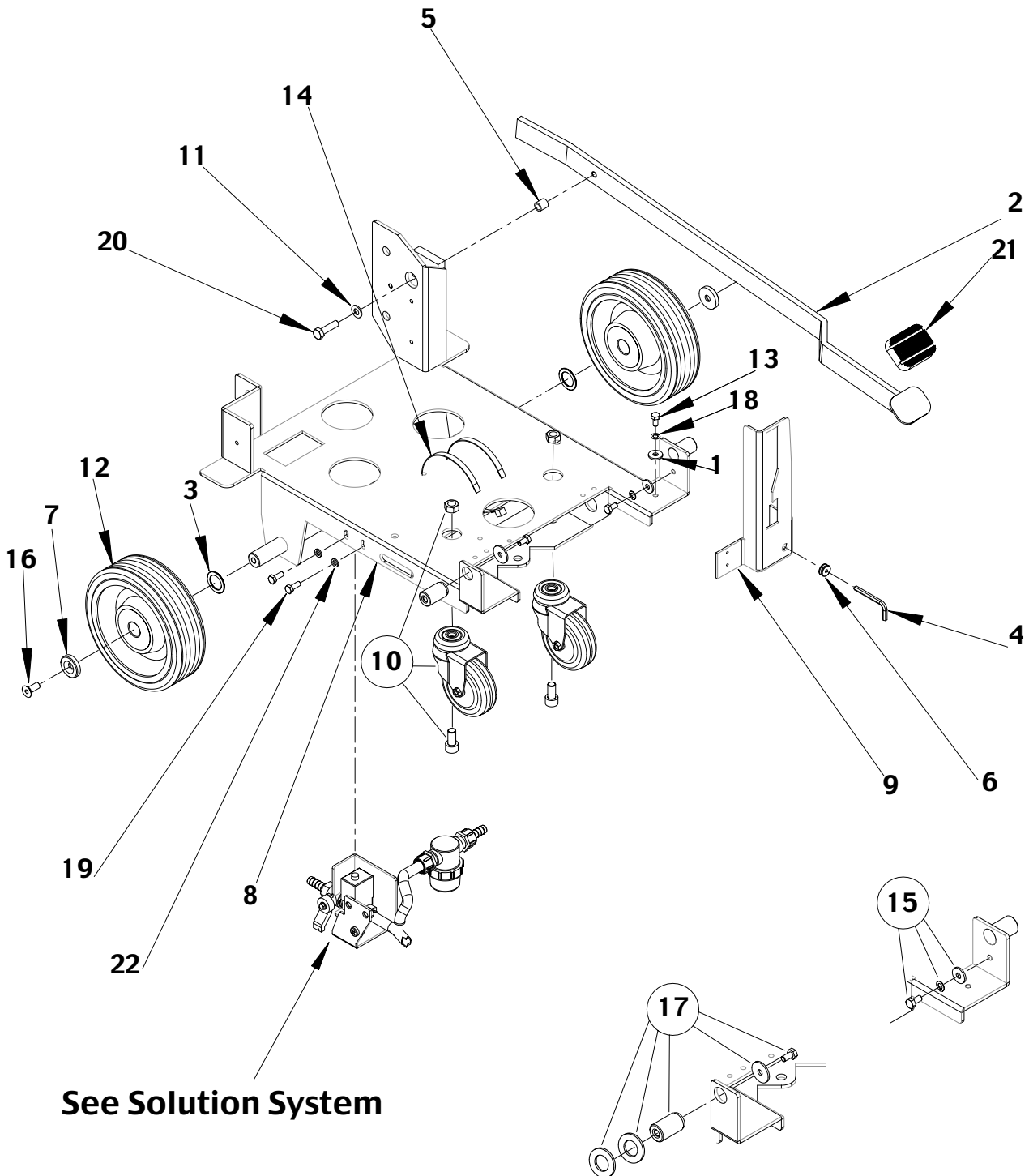

2003-09	CHASSIS SYSTEM			
	RAZOR 17B/ RAZOR 20B			11

Item no.	Ref. No.	Qty	Description
1	xxxxxxx	2	Washer flat (Chassis System Hardware Kit)
2#	L08812925	1	Pedal, brush lifting
3#	L08812936	2	Spacer
4#	L08063800	1	Key
5#	L08812324	2	Spacer
6#	L08812388	1	Cable guide
7#	L08812392	2	Spacer
8#	L08812888	1	Chassis
9#	L08812893	1	Guide
10#	L08603861	1	Kit castor wheel rear
11	xxxxxxx	3	Washer flat (Chassis System Hardware Kit)
12#	L08812939	2	Wheel front
13	xxxxxxx	3	Screw hex hd M6x12 (Chassis System Hardware Kit)
14	xxxxxxx	2	Clamp (Chassis System Hardware Kit)
15#	L08603862	1	Kit tank support right
16	xxxxxxx	2	Screw M8x20 (Chassis System Hardware Kit)
17#	L08603863	1	Kit tank support left
18	145 9228 000	2	Washer
19	xxxxxxx	2	Screw hex hd M6x16 (Chassis System Hardware Kit)
20	xxxxxxx	1	Screw hex hd M8x30 (Chassis System Hardware Kit)
21	145 8478 000	1	Pedal cover
22	xxxxxxx	2	Washer flat (Chassis System Hardware Kit)
[23]#	L08603957	1	Chassis System Hardware Kit

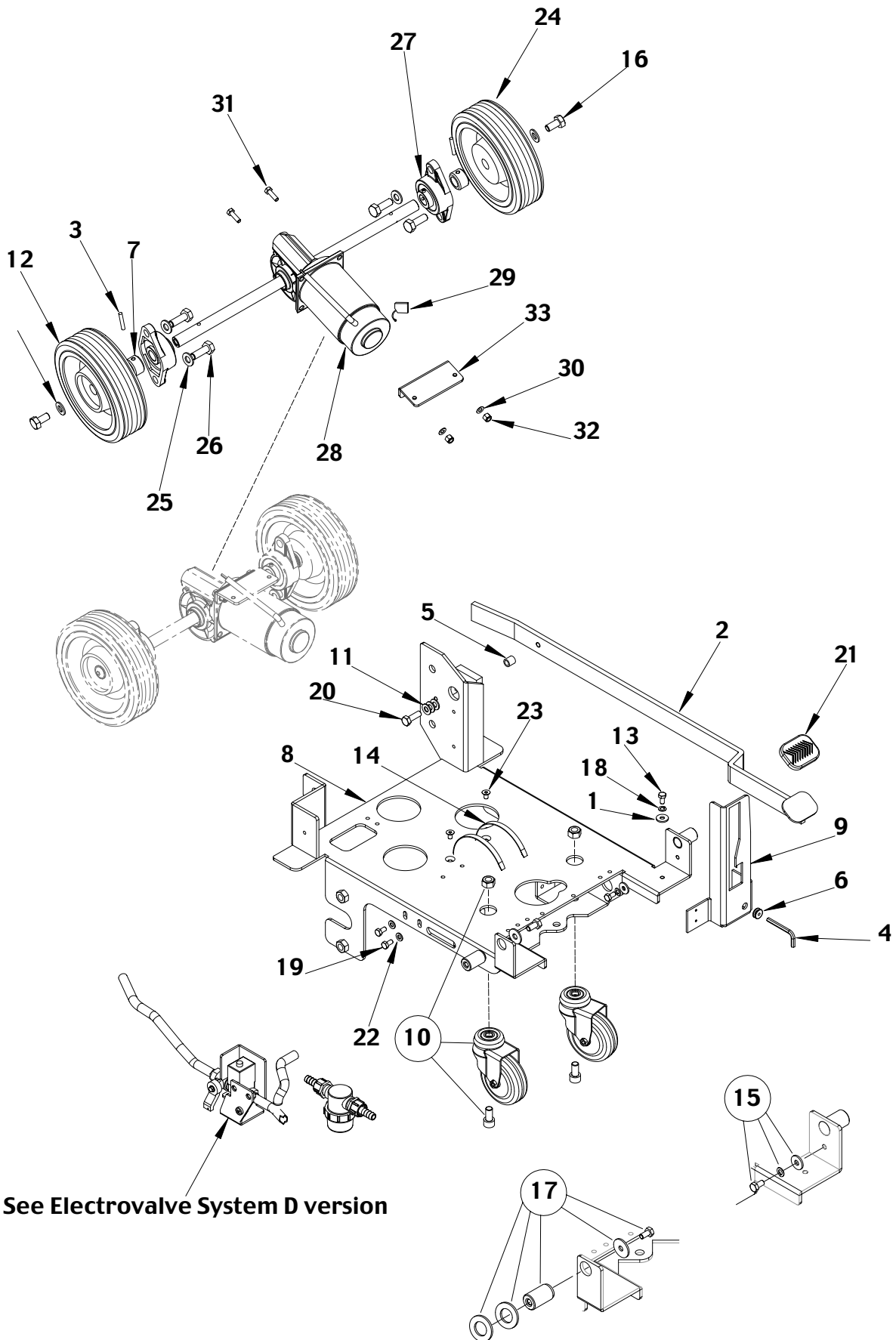

2003-09	CHASSIS SYSTEM		
	RAZOR 20BT		13

Item no.	Ref. No.	Qty	Description
1#	L08228600	2	Washer flat
2#	L08812925	1	Pedal, brush lifting
3	145 4546 000	2	Retaining ring (Reductiongear motor kit)
4#	L08063800	1	Key
5#	L08812324	2	Spacer
6#	L08812388	1	Cable guide
7	909 5272 000	2	Spacer (Reductiongear motor kit)
8	909 5128 000	1	Chassis
9#	L08812893	1	Guide
10#	L08603861	1	Kit castor wheel rear
11#	L08085700	3	Washer flat
12	909 5112 000	1	Wheel
13#	L08326100	2	Screw hex hd M6x12
14	145 0541 000	2	Clamp
15#	L08603862	1	Kit tank support right
16	145 4473 000	2	Screw hex hd M10x20
17#	L08603863	1	Kit tank support left
18	145 9228 000	2	Washer
19	145 9261 000	2	Screw hex hd M6x16
20#	L08367300	1	Screw hex hd M8x25
21	145 8478 000	1	Pedal cover
22	145 9128 000	2	Washer flat
23	146 0765 000	2	Screw M61x10
24	909 5111 000	1	Wheel, front right
25	145 9320 000	6	Washer flat 10x21
26	145 9874 000	4	Screw hex hd M10x30
27	909 5131 000	2	Flange
28	909 5273 000	1	Reductiongear motor kit (3,7)
29	909 5157 000	2	Carbon brush for reductiongear motor 909 5271 000 (Reductiongear motor kit)
30#	L08602395	2	Washer flat
31	145 9227 000	2	Screw hex hd M6x20
32#	L08251000	2	Nut hex selflock.M6
33	909 5129 000	1	Bracket

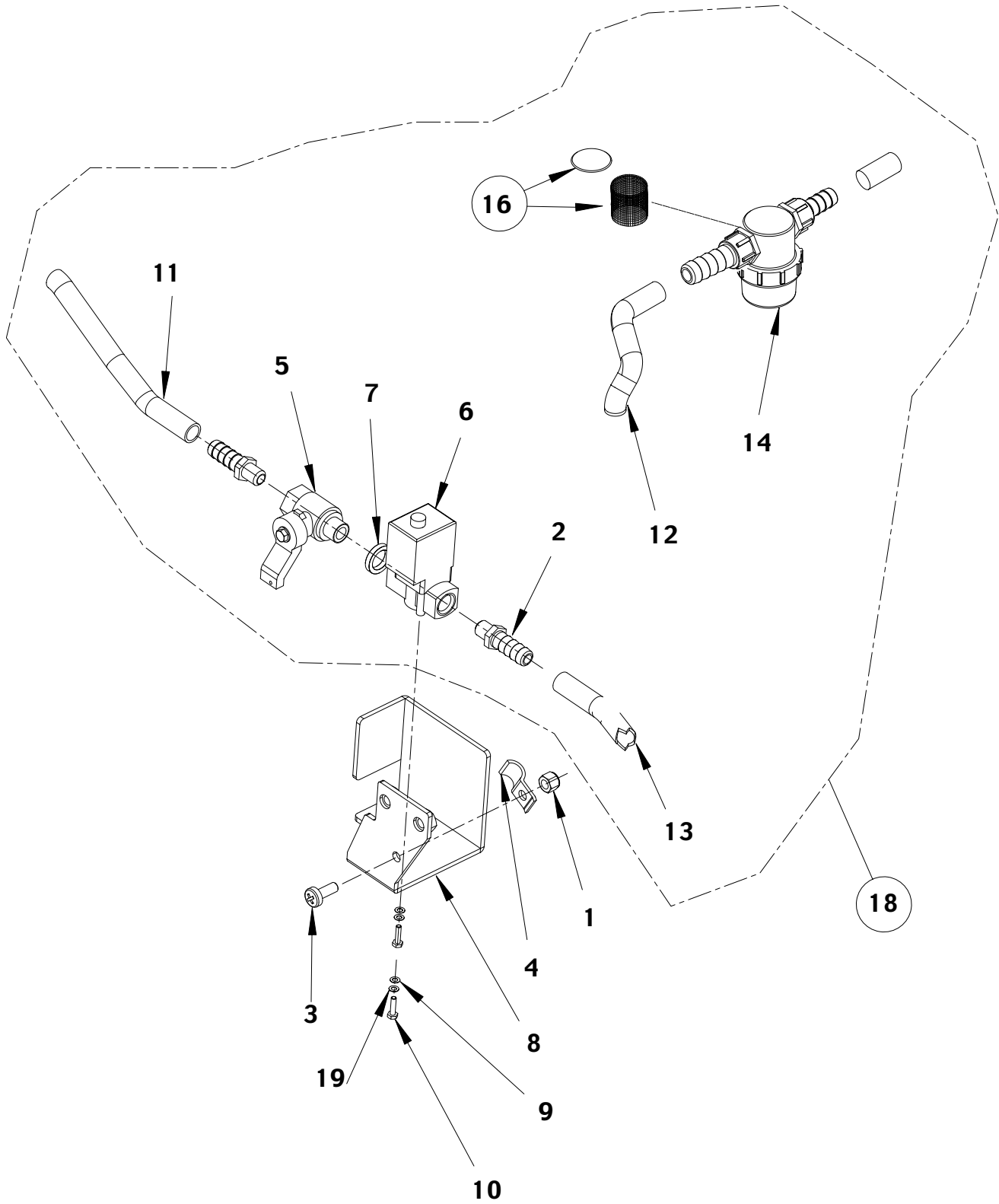

2003-09	SOLUTION SYSTEM before serial number 1665510			
	RAZOR 17B/ RAZOR 20B			15

Item no.	Ref. No.	Qty	Description
1	xxxxxxx	1	Nut hex M6 selflock. (Solution System Hardware Kit)
2#	L08601624	2	Pipe holder
3	xxxxxxx	1	Screw M6x16 (Solution System Hardware Kit)
4	xxxxxxx	1	Clamp (Solution System Hardware Kit)
5#	L08812427	1	Ball grip thread
6#	L08812960	1	Solenoid valve 24V
7#	L08812257	1	Nut
8#	L08812974	1	Solenoid valve bracket
9	xxxxxxx	2	Washer (Solution System Hardware Kit)
10	xxxxxxx	2	Screw hex hd M3x12 SS (Solution System Hardware Kit)
11#	L08603854	1	Hose 270 mm length
12#	L08603855	1	Hose 560 mm length
13#	L08603853	1	Hose 150 mm length
14	909 5151 000	1	Water filter
16#	L08603893	1	Kit net filter with gasket
18#	L08603898	1	Solenoid valve kit compl.
19	xxxxxxx	2	Washer flat (Solution System Hardware Kit)
[20]#	L08603958	1	Solution System Hardware Kit

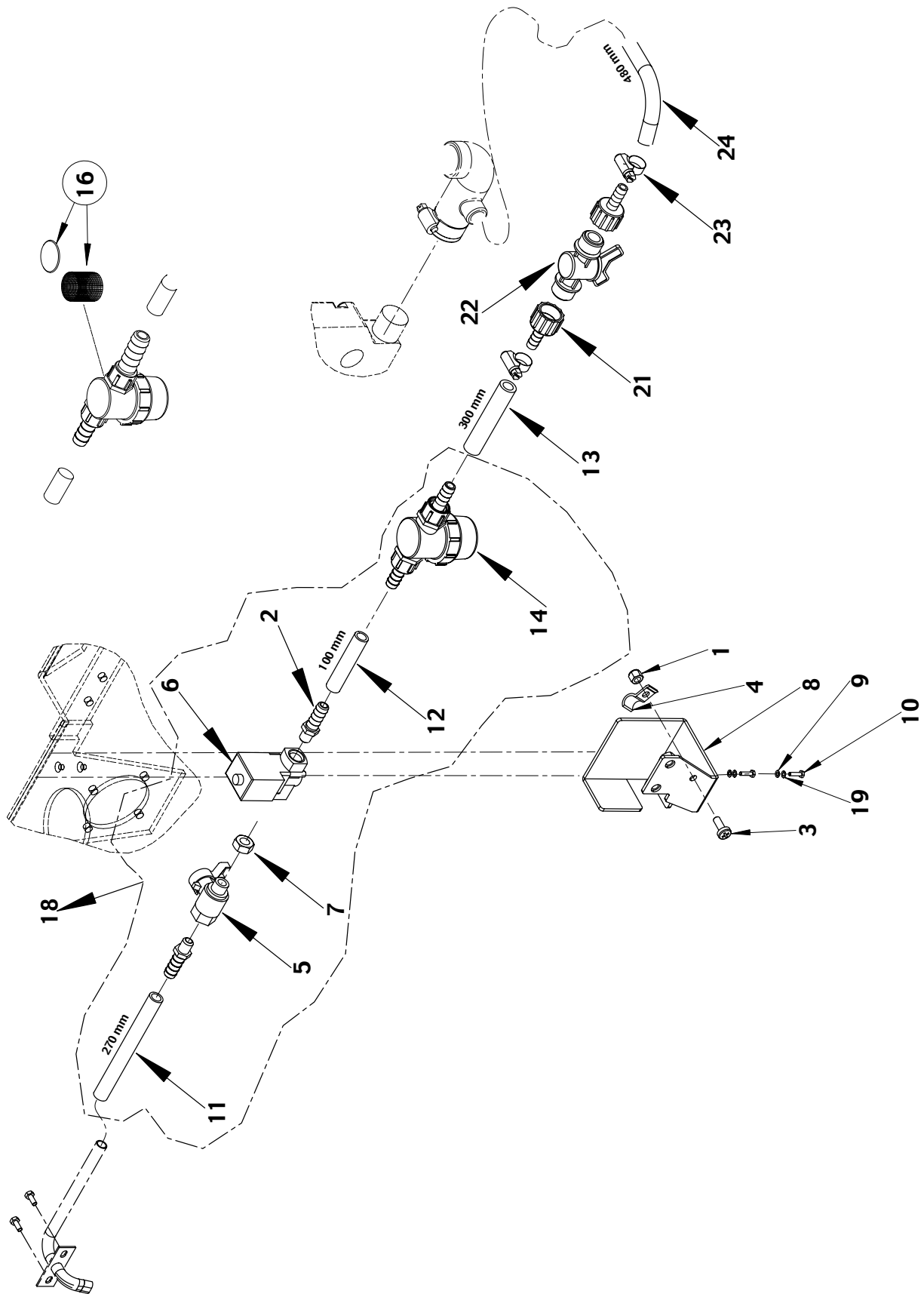

2003-09	SOLUTION SYSTEM from serial number 1665510		
	RAZOR 17B/ RAZOR 20B		17

Item no.	Ref. No.	Qty	Description
1	xxxxxxx	1	Nut hex M6 selflock. (Solution System Hardware Kit)
2#	L08601624	2	Pipe holder
3	xxxxxxx	1	Screw m6x16 (Solution System Hardware Kit)
4	xxxxxxx	1	Clamp (Solution System Hardware Kit)
5#	L08812427	1	Ball grip thread
6#	L08812960	1	Solenoid valve 24V
7#	L08812257	1	Nut
8#	L08812974	1	Solenoid valve bracket
9	xxxxxxx	2	Washer (Solution System Hardware Kit)
10	xxxxxxx	2	Screw hex hd M3x12 SS (Solution System Hardware Kit)
11	L08603854	1	Hose 270 mm length
12	909 5026 000	1	Hose 100 mm length
13	909 5025 000	1	Hose 300 mm length
14	909 5151 000	1	Water filter
16#	L08603893	1	Kit net filter with gasket
18	909 5032 00	1	Solenoid valve kit compl.TSB IT 2003-007 (a)
18#	L08603898	1	Solenoid valve kit compl.TSB IT 2003-007 (b)
19	xxxxxxx	2	Washer flat (Solution System Hardware Kit)
[20]#	L08603958	1	Solution System Hardware Kit
21	909 5022 000	2	Holder pipe ø11
22	909 5023 000	1	Water valve
23	145 8582 000	2	Clamp
24	909 5024 000	1	Hose 480 mm length

(a) kit to be kept for scrubbers before serial number 032004955 (b) kit to be used for scrubbers after serial number 1665510

TSB IT 2003-007

FORM NO. L08812947

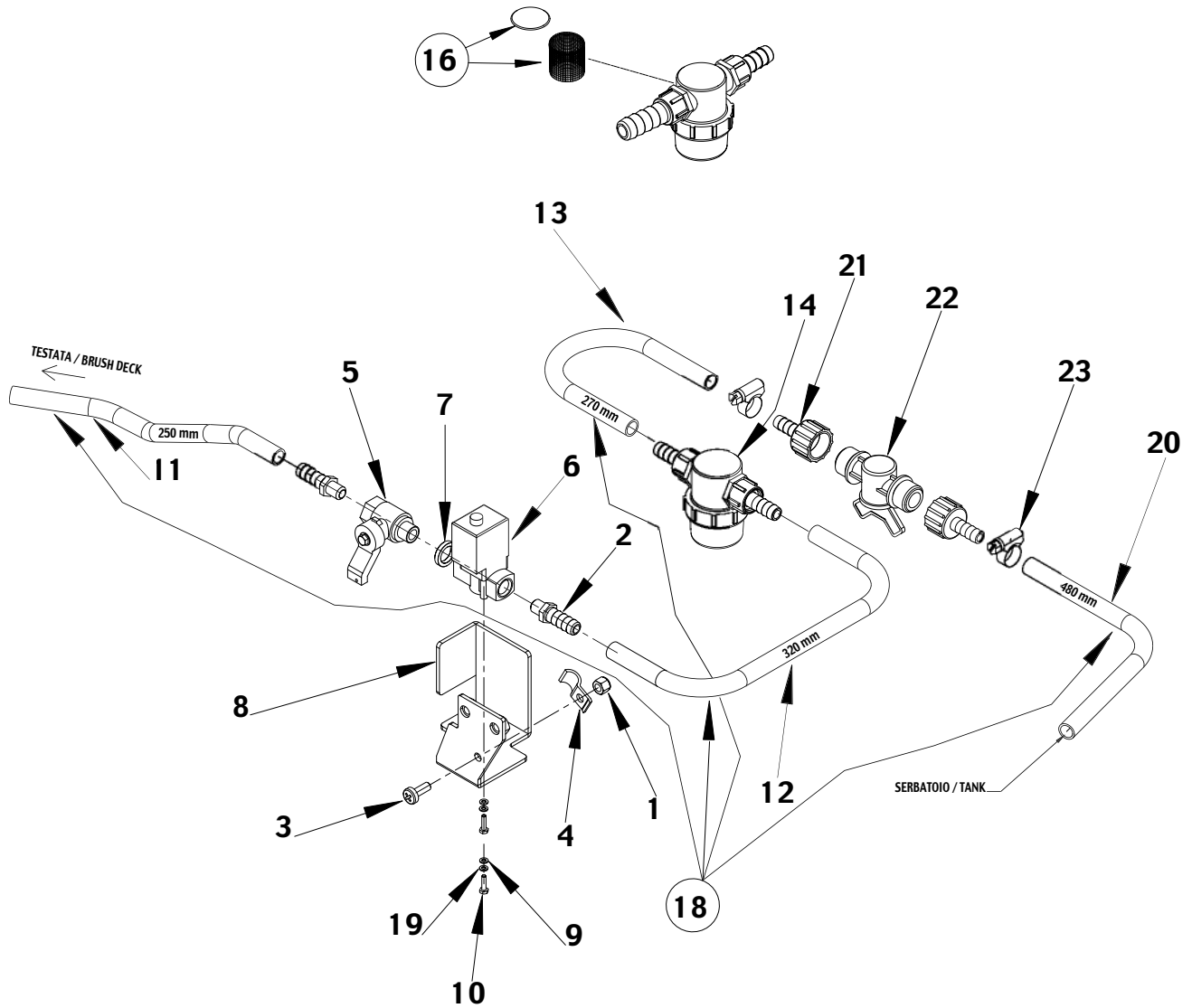

2003-09	SOLUTION SYSTEM		
	RAZOR 20BT		19

Item no.	Ref. No.	Qty	Description
1#	L08361400	1	Nut hex M6 selflock.
2#	L08601624	2	Pipe holder
3	145 9261 000	1	Screw M6x16
4#	L08812352	1	Clamp
5#	L08812427	1	Ball grip thread
6#	L08812960	1	Solenoid valve 24V
7#	L08812257	1	Nut
8#	L08812974	1	Solenoid valve bracket
9#	L08812986	2	Washer
10#	L08603895	2	Screw hex hd M3x12
11	xxx xxxx xxx	1	Hose 250 mm length (Hoses, Solenoid Valve Kit)
12	xxx xxxx xxx	1	Hose 320 mm length (Hoses, Solenoid Valve Kit)
13#	L08603854	1	Hose 270 mm length (Hoses, Solenoid Valve Kit)
14	909 5151 000	1	Water filter
16#	L08603893	1	Kit net filter with gasket
18	909 5158 000	1	Hoses solenoidvalve kit (11,12,13,20)
19#	L08812097	2	Washer flat SS
20	xxx xxxx xxx	1	Hose 480 mm length (Hoses, Solenoid Valve Kit)
21	909 5022 000	2	Holder pipe ø11
22	909 5023 000	1	Water valve
23	145 8582 000	2	Clamp

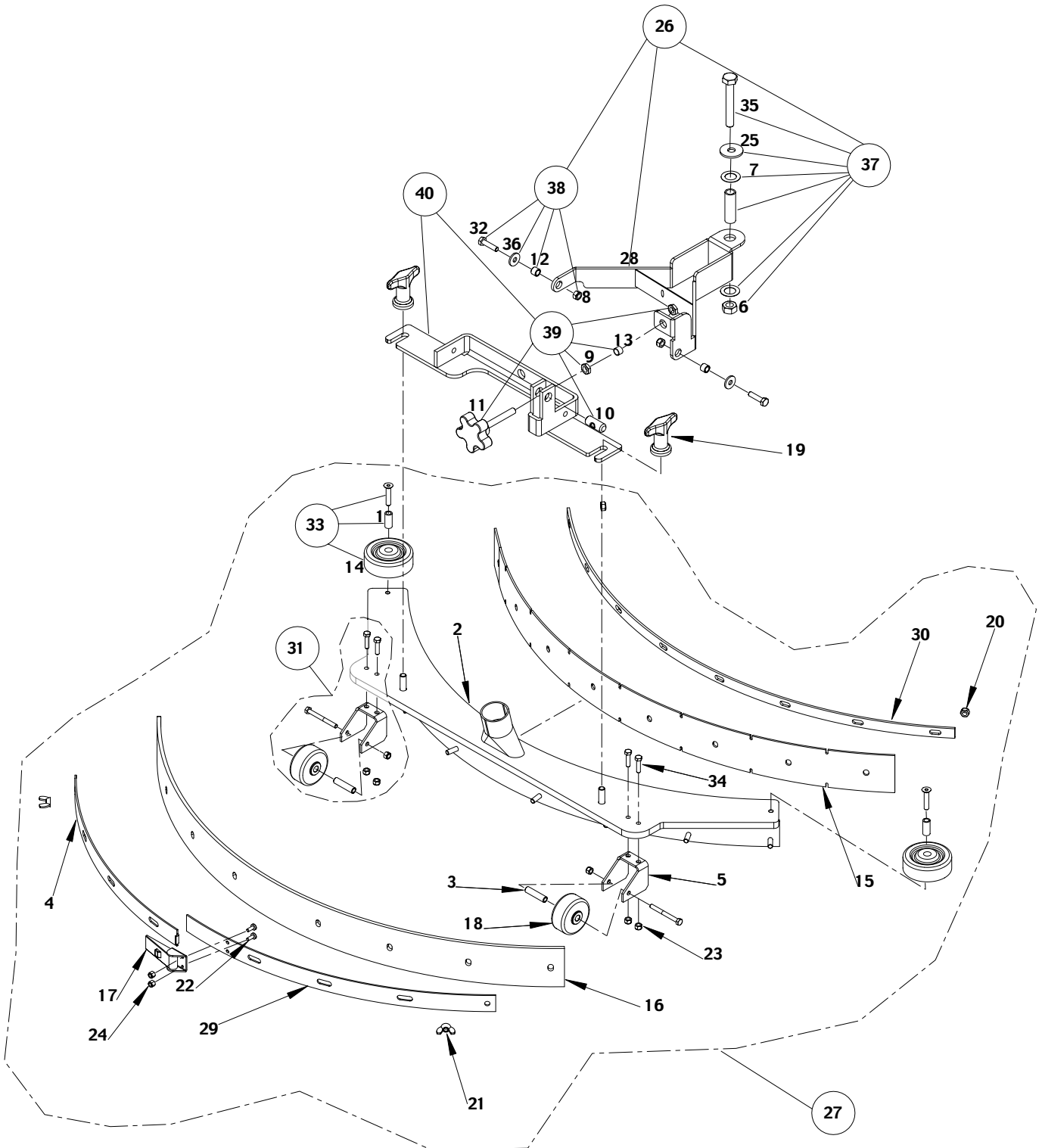

2003-09	SQUEEGEE ASSEMBLY		
	RAZOR 17B/ RAZOR 20B/ RAZOR 20BT		21

Item no.	Ref. No.	Qty	Description
1#	L08812937	2	Spacer
2#	L08603676	1	Squeegee Tool
3#	L08812948	2	Spacer
4#	L08603670	1	Rear strap for latch left
5#	L08603666	2	Support squeegee wheel
6	xxxxxxx	1	Nut (Squeegee Assembly Hardware Kit)
7	xxxxxxx	2	Washer flat (Squeegee Assembly Hardware Kit)
8	xxxxxxx	2	Nut (Squeegee Assembly Hardware Kit)
9	xxxxxxx	2	Nut (Squeegee Assembly Hardware Kit)
10#	L08601509	1	Pin
11#	L08601574	1	Knob
12#	L08601854	2	Spacer
13#	L08602422	1	Spacer
14#	L08602460	2	Bumper roller
15#	L08602463	1	Squeegee blade front
16#	L08602468	1	Squeegee blade rear
17#	L08603664	1	Latch for squeegee
18#	L08603665	2	Rubber wheel
19#	L08603675	2	Thumb nut
20#	L08603682	8	Nut
21	xxxxxxx	2	Wing nut (Squeegee Assembly Hardware Kit)
22	xxxxxxx	2	Screw (Squeegee Assembly Hardware Kit)
23	xxxxxxx	6	Nut (Squeegee Assembly Hardware Kit)
24	xxxxxxx	2	Nut (Squeegee Assembly Hardware Kit)
25	xxxxxxx	1	Washer, flat 10x30
26#	L08603877	1	Kit squeegee sup. bracket
27#	L08603878	1	Kit squeegee complete
28#	L08812935	1	Bracket
29#	L08603669	1	Rear strap for hook right
30#	L08603672	1	Strap, front
31#	L08603879	1	Kit squeegee wheel
32	xxxxxxx	2	Screw
33#	L08603880	1	Kit squ.bumper roller
34	xxxxxxx	4	Screw (Squeegee Assembly Hardware Kit)
35	xxxxxxx	1	Screw (Squeegee Assembly Hardware Kit)
36	xxxxxxx	2	Washer flat (Squeegee Assembly Hardware Kit)
37#	L08812516	1	Fixture kit
38#	L08812521	1	Fixt.nozzle holder left / right kit
39#	L08812518	1	Adjustment screw kit
40#	L08603876	1	Kit squeegee holder
[41]#	L08603959	1	Squeegee Assembly Hardware Kit

Razor 17B

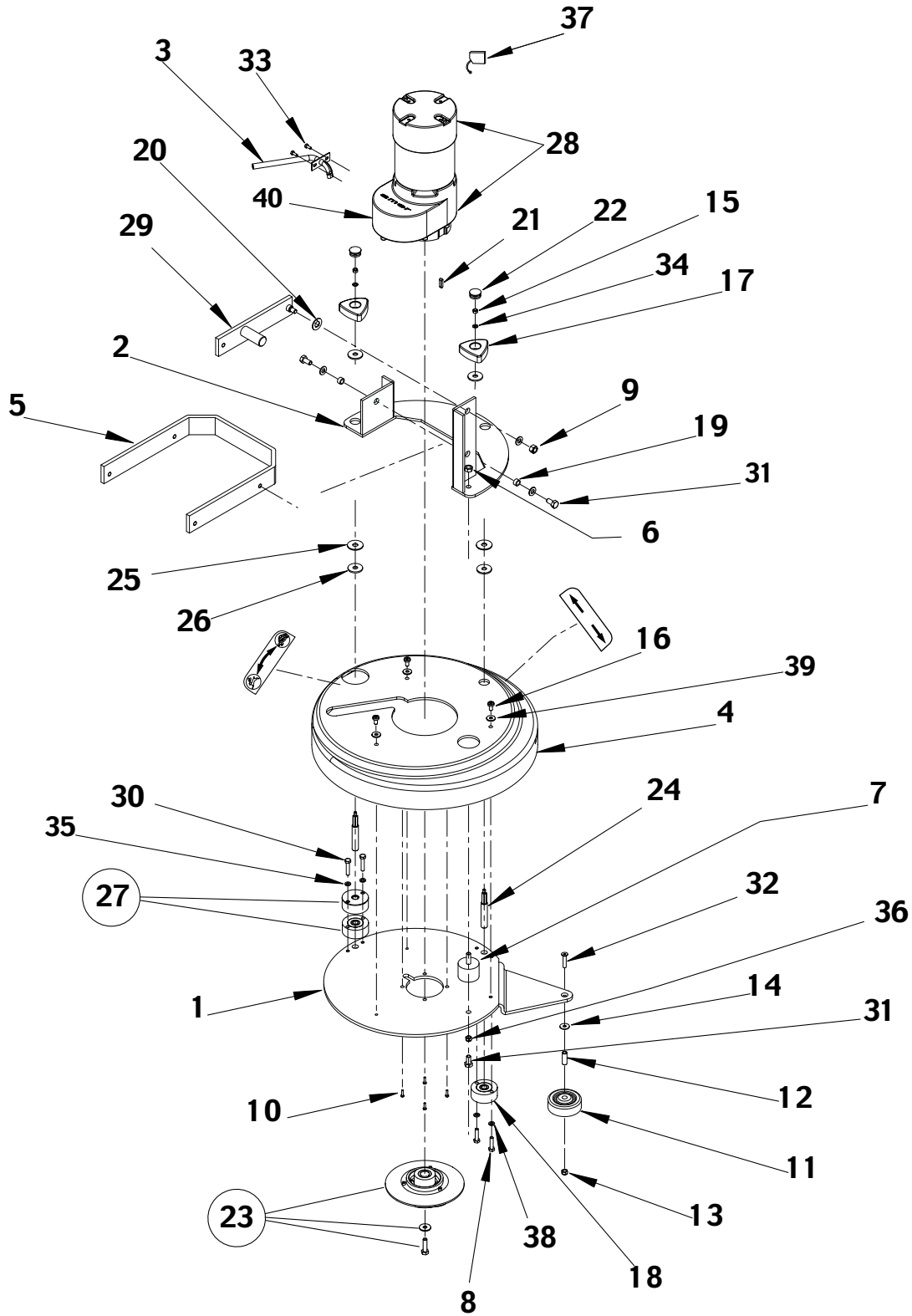

2003-09	BRUSH SYSTEM RAZOR 17B			
	RAZOR 17B			23

Item no.	Ref. No.	Qty	Description
1#	L08812889	1	Plate, brush holder
2#	L08812892	1	Plate
3#	L08812921	1	Hose copper
4#	L08812922	1	Brush cover Razor 17B
5#	L08812924	1	Frame brush lifting
6	xxxxxxx	1	Nut hex M8 (Brush System Hardware Kit)
7	xxxxxxx	1	Vibration damping M8 (Brush System Hardware Kit)
8	xxxxxxx	2	Screw hex hd M6x25 (Brush System Hardware Kit)
9	xxxxxxx	1	Nut selflocking M8 (Brush System Hardware Kit)
10	xxxxxxx	4	Screw hex hd M6x16 SS (Brush System Hardware Kit)
11#	L08602460	1	Bumper roller
12#	L08602461	1	Bushing
13	xxxxxxx	1	Nut hex selflocking M6 (Brush System Hardware Kit)
14	xxxxxxx	1	Washer flat 6x18 (Brush System Hardware Kit)
15	xxxxxxx	2	Nut hex selflocking M5 (Brush System Hardware Kit)
16	xxxxxxx	3	Screw 6x16 (Brush System Hardware Kit)
17#	L08812203	2	Knob for brush plate
18#	L08812213	1	Buffer for brush plate
19#	L08812325	2	Bushing
20	xxxxxxx	1	Washer (Brush System Hardware Kit)
21	145 9774 000	1	Key
22#	L08812426	2	Cap for knob
23#	L08812589	1	Polygonal holder kit
24#	L08812706	2	Dowel broom plate fixing
25#	L08812718	2	Washer rubber
26	xxxxxxx	4	Washer flat 7x18 (Brush System Hardware Kit)
27#	L08812780	1	Brush plate fixing kit
28#	L08812919	1	Reduction gearmotor
29#	L08812929	1	Brush lifting lever
30	xxxxxxx	2	Screw hex hd M6x30 (Brush System Hardware Kit)
31	xxxxxxx	3	Screw hex hd M8x16 (Brush System Hardware Kit)
32	xxxxxxx	1	Screw M6x40 (Brush System Hardware Kit)
33	xxxxxxx	2	Screw hex hd M4x8 (Brush System Hardware Kit)
34	xxxxxxx	2	Washer flat 5x10 (Brush System Hardware Kit)
35	xxxxxxx	2	Washer flat 6x12,5 (Brush System Hardware Kit)
36	xxxxxxx	3	Washer flat 8x17 (Brush System Hardware Kit)
37#	L08603850	1	Carbon brush set
38	xxxxxxx	2	Washer hex. (Brush System Hardware Kit)
39	xxxxxxx	3	Washer flat 6x18 (Brush System Hardware Kit)
40#	L08603849	1	Reduction gear
[41]#	L08603960	1	Brush System Hardware Kit

Razor 20B

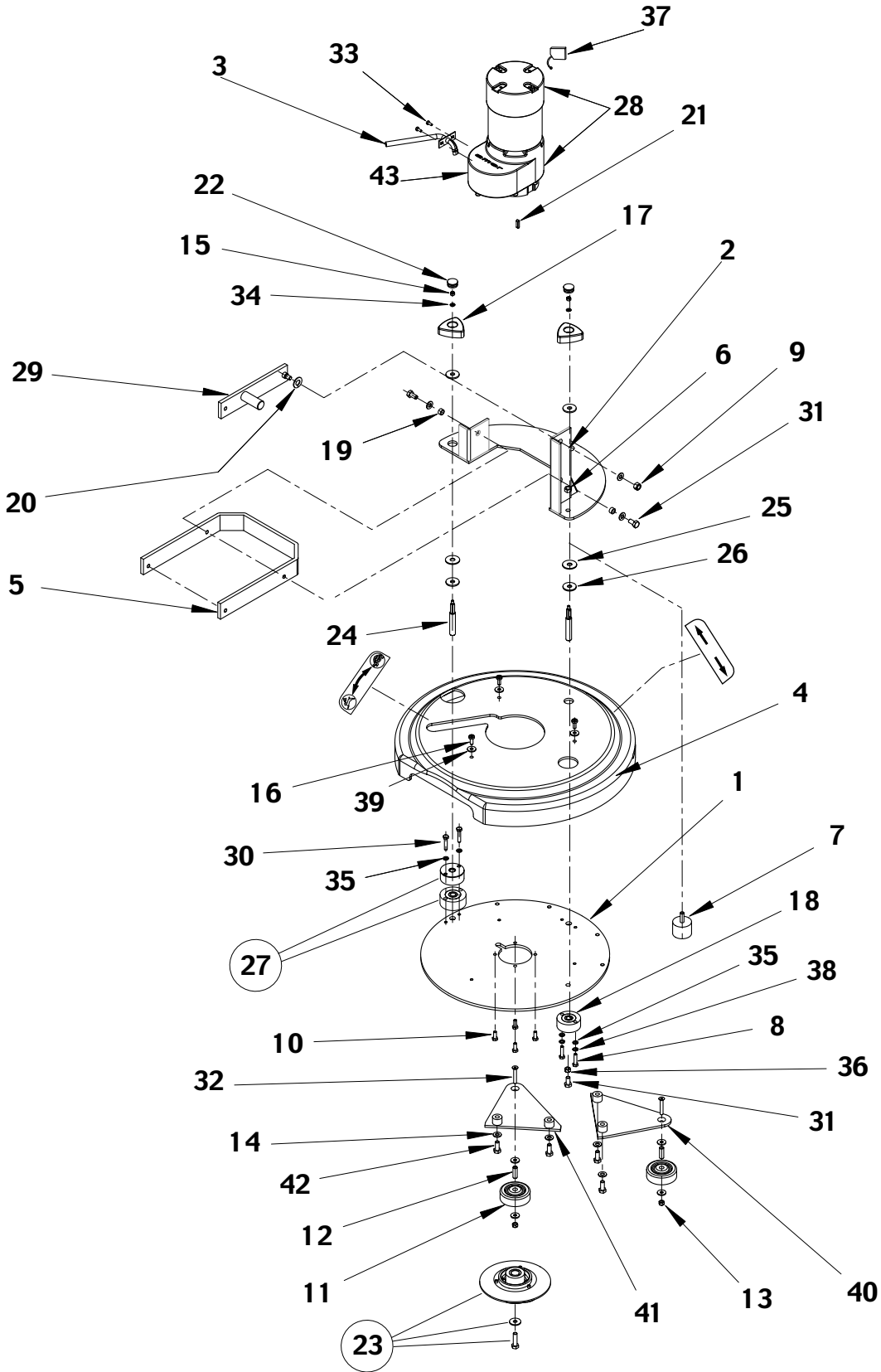

2003-09	BRUSH SYSTEM RAZOR 20B			
	RAZOR 20B			25

Item no.	Ref. No.	Qty	Description
1#	L08812981	1	Plate brush holder
2#	L08812980	1	Plate
3#	L08812921	1	Hose copper
4#	L08812979	1	Brush cover Razor 20B
5#	L08812924	1	Frame brush lifting
6	xxxxxxx	1	Nut hex M8 (Brush System Hardware Kit)
7	xxxxxxx	1	Vibration damping M8 (Brush System Hardware Kit)
8	xxxxxxx	2	Screw hex hd M6x25 (Brush System Hardware Kit)
9	xxxxxxx	1	Nut hex selflocking M8 (Brush System Hardware Kit)
10	xxxxxxx	4	Screw hex hd M6x16 SS (Brush System Hardware Kit)
11#	L08602460	2	Bumper roller
12#	L08602461	2	Bushing
13	xxxxxxx	2	Nut hex selflocking M6 (Brush System Hardware Kit)
14	xxxxxxx	2	Washer flat 6x18 (Brush System Hardware Kit)
15	xxxxxxx	2	Nut hex selflocking M5 (Brush System Hardware Kit)
16	xxxxxxx	3	Screw M6x16 (Brush System Hardware Kit)
17#	L08812203	2	Knob for brush plate
18#	L08812213	1	Buffer for brush plate
19#	L08812325	2	Bushing
20	xxxxxxx	1	Washer (Brush System Hardware Kit)
21	145 9774 000	1	Key
22#	L08812426	2	Cap for knob
23#	L08812589	1	Polygonal holder kit
24#	L08812706	2	Dowel brush plate fixing
25#	L08812718	2	Washer rubber
26	xxxxxxx	4	Washer flat 7x18 (Brush System Hardware Kit)
27#	L08812780	1	Brush plate fixing kit
28#	L08812919	1	Reduction gearmotor
29#	L08812929	1	Brush lifting lever
30	xxxxxxx	2	Screw hex hd M6x30 (Brush System Hardware Kit)
31	xxxxxxx	3	Screw hex hd M8x16 (Brush System Hardware Kit)
32	xxxxxxx	2	Screw M6x40 (Brush System Hardware Kit)
33	xxxxxxx	2	Screw hex hd M4x8 (Brush System Hardware Kit)
34	xxxxxxx	2	Washer flat 5x10 (Brush System Hardware Kit)
35	xxxxxxx	2	Washer flat 6x12,5 (Brush System Hardware Kit)
36	xxxxxxx	6	Washer flat 8x17 (Brush System Hardware Kit)
37#	L08603850	1	Carbon brush set
38	xxxxxxx	2	Washer hex. (Brush System Hardware Kit)
39	xxxxxxx	3	Washer flat 6x18 (Brush System Hardware Kit)
40#	L08812982	1	Bumper roll. support right
41#	L08812983	1	Bumper roll. support left
42	xxxxxxx	4	Screw hex hd M8x25 SS (Brush System Hardware Kit)
43#	L08603849	1	Reduction gear
[44]#	L08603960	1	Brush System Hardware Kit

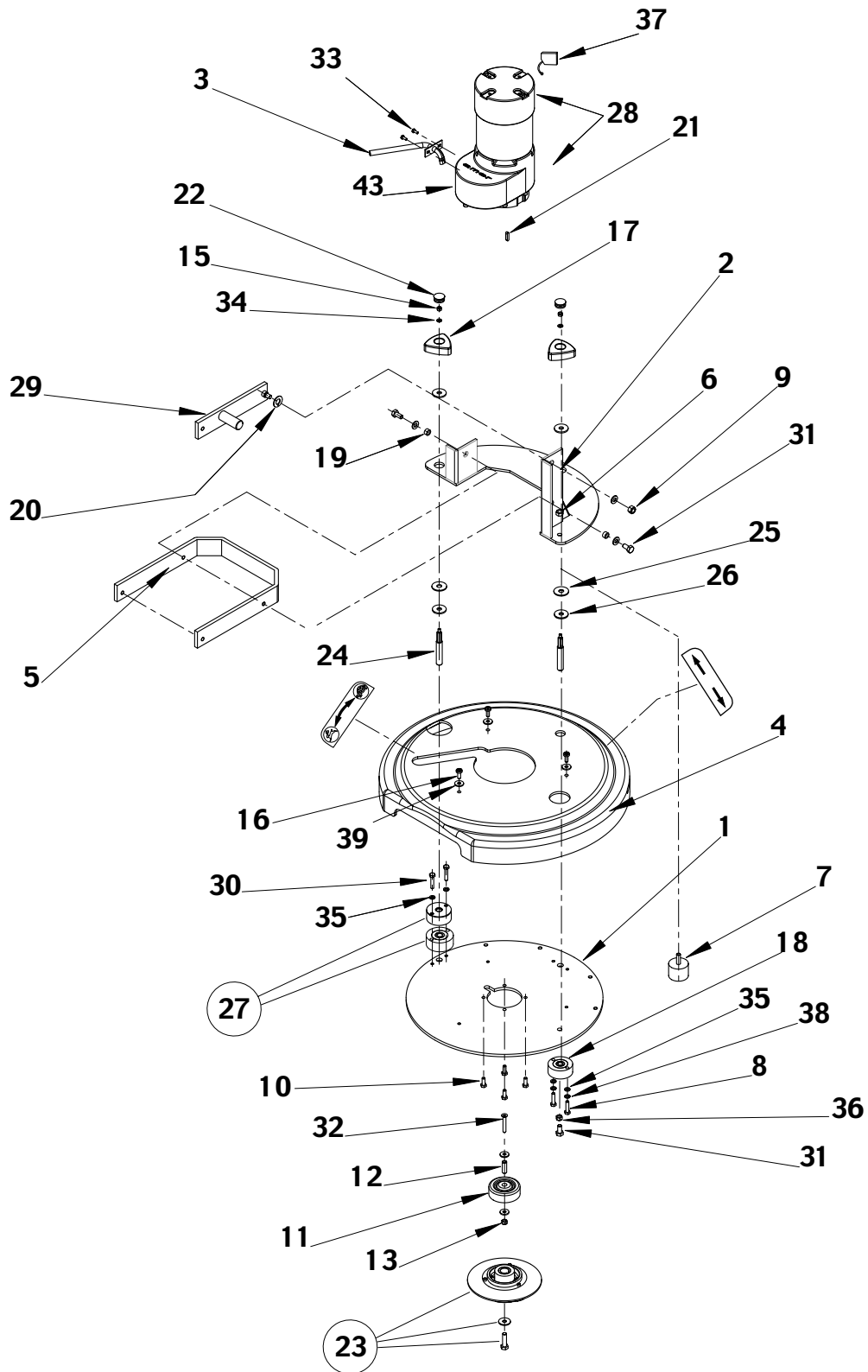

2003-09	OFF SET BRUSH SYSTEM RAZOR 20BT			
	RAZOR 20BT			27

Item no.	Ref. No.	Qty	Description
1	909 5135 000	1	Plate brush holder
2	909 5136 000	1	Plate
3#	L08812921	1	Hose copper
4	909 5134 000	1	Brush cover Razor 20B
5#	L08812924	1	Frame brush lifting
6	xxxxxxx	1	Nut hex M8 (Brush System Hardware Kit)
7	xxxxxxx	1	Vibration damping M8 (Brush System Hardware Kit)
8	xxxxxxx	2	Screw hex hd M6x25 (Brush System Hardware Kit)
9	xxxxxxx	1	Nut hex selflocking M8 (Brush System Hardware Kit)
10	xxxxxxx	4	Screw hex hd M6x16 SS (Brush System Hardware Kit)
11#	L08602460	2	Bumper roller
12#	L08602461	2	Bushing
13	xxxxxxx	2	Nut hex selflocking M6 (Brush System Hardware Kit)
15	xxxxxxx	2	Nut hex selflocking M5 (Brush System Hardware Kit)
16	xxxxxxx	3	Screw M6x16 (Brush System Hardware Kit)
17#	L08812203	2	Knob for brush plate
18#	L08812213	1	Buffer for brush plate
19#	L08812325	2	Bushing
20	xxxxxxx	1	Washer (Brush System Hardware Kit)
21	145 9774 000	1	Key
22#	L08812426	2	Cap for knob
23#	L08812589	1	Polygonal holder kit
24#	L08812706	2	Dowel brush plate fixing
25#	L08812718	2	Washer rubber
26	xxxxxxx	4	Washer flat 7x18 (Brush System Hardware Kit)
27#	L08812780	1	Brush plate fixing kit
28#	L08812919	1	Reduction gearmotor
29#	L08812929	1	Brush lifting lever
30	xxxxxxx	2	Screw hex hd M6x30 (Brush System Hardware Kit)
31	xxxxxxx	3	Screw hex hd M8x16 (Brush System Hardware Kit)
32	xxxxxxx	2	Screw M6x40 (Brush System Hardware Kit)
33	xxxxxxx	2	Screw hex hd M4x8 (Brush System Hardware Kit)
34	xxxxxxx	2	Washer flat 5x10 (Brush System Hardware Kit)
35	xxxxxxx	2	Washer flat 6x12,5 (Brush System Hardware Kit)
36	xxxxxxx	6	Washer flat 8x17 (Brush System Hardware Kit)
37#	L08603850	1	Carbon brush set
38	xxxxxxx	2	Washer hex. (Brush System Hardware Kit)
39	xxxxxxx	3	Washer flat 6x18 (Brush System Hardware Kit)
43#	L08603849	1	Reduction gear

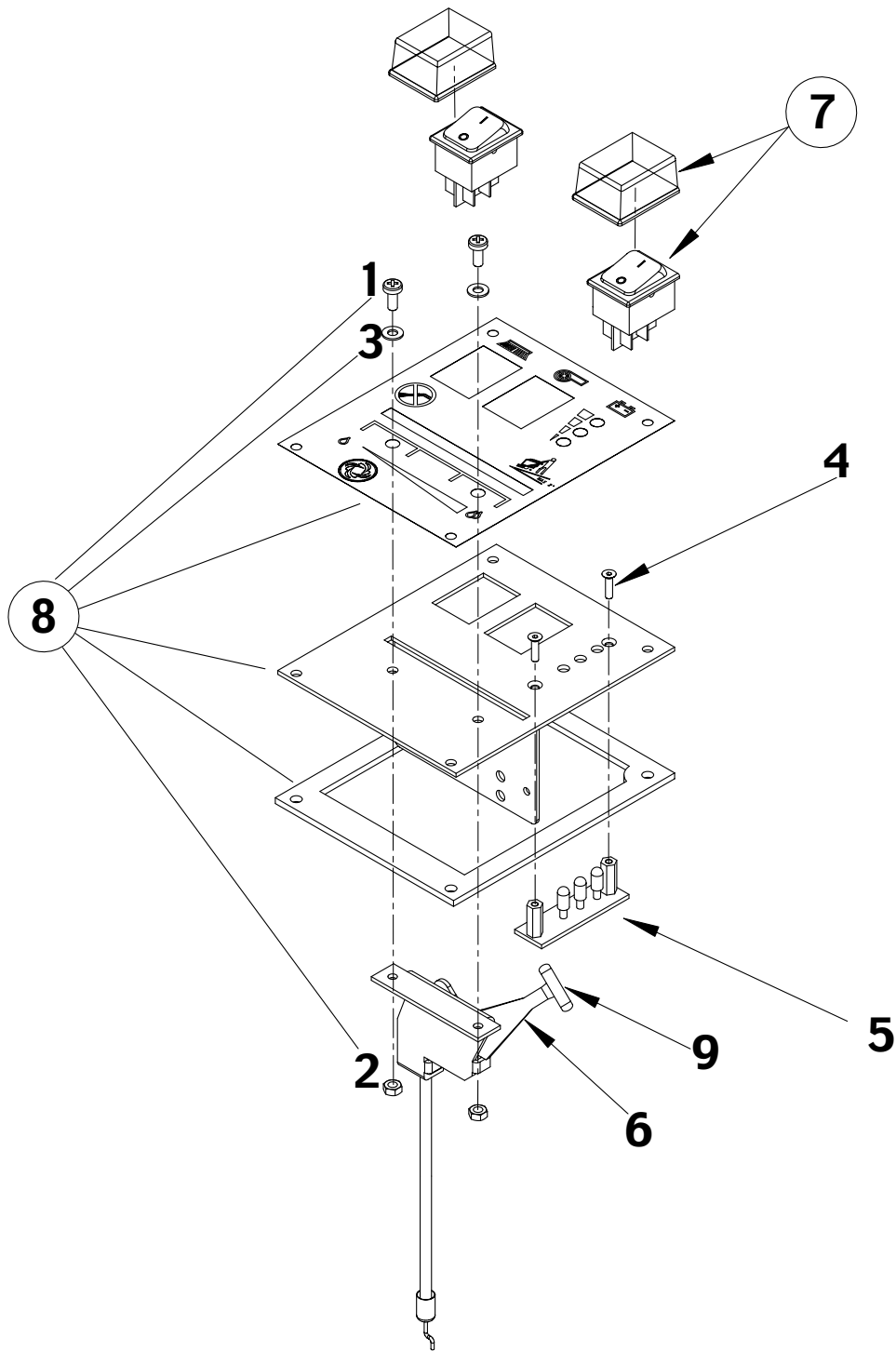

2003-09	CONTROL PANEL SYSTEM		
	RAZOR 17B/ RAZOR 20B/ RAZOR 20BT		29

Item no.	Ref. No.	Qty	Description
1	xxxxxxx	2	Screw M4x10 (Control Panel System Hardware Kit)
2	xxxxxxx	2	Nut hex M4 (Control Panel System Hardware Kit)
3	xxxxxxx	2	Washer falt (Control Panel System Hardware Kit)
4	xxxxxxx	2	Screw 3x8 (Control Panel System Hardware Kit)
5#	L08812909	1	Led board
6#	L08812938	1	Lever
7#	L08812562	1	Kit switch complete
8#	L08603866	1	Kit control panel w/decal
9#	L08603790	1	Handle for lever
[10]#	L08603961	1	Control Panel System Hardware Kit

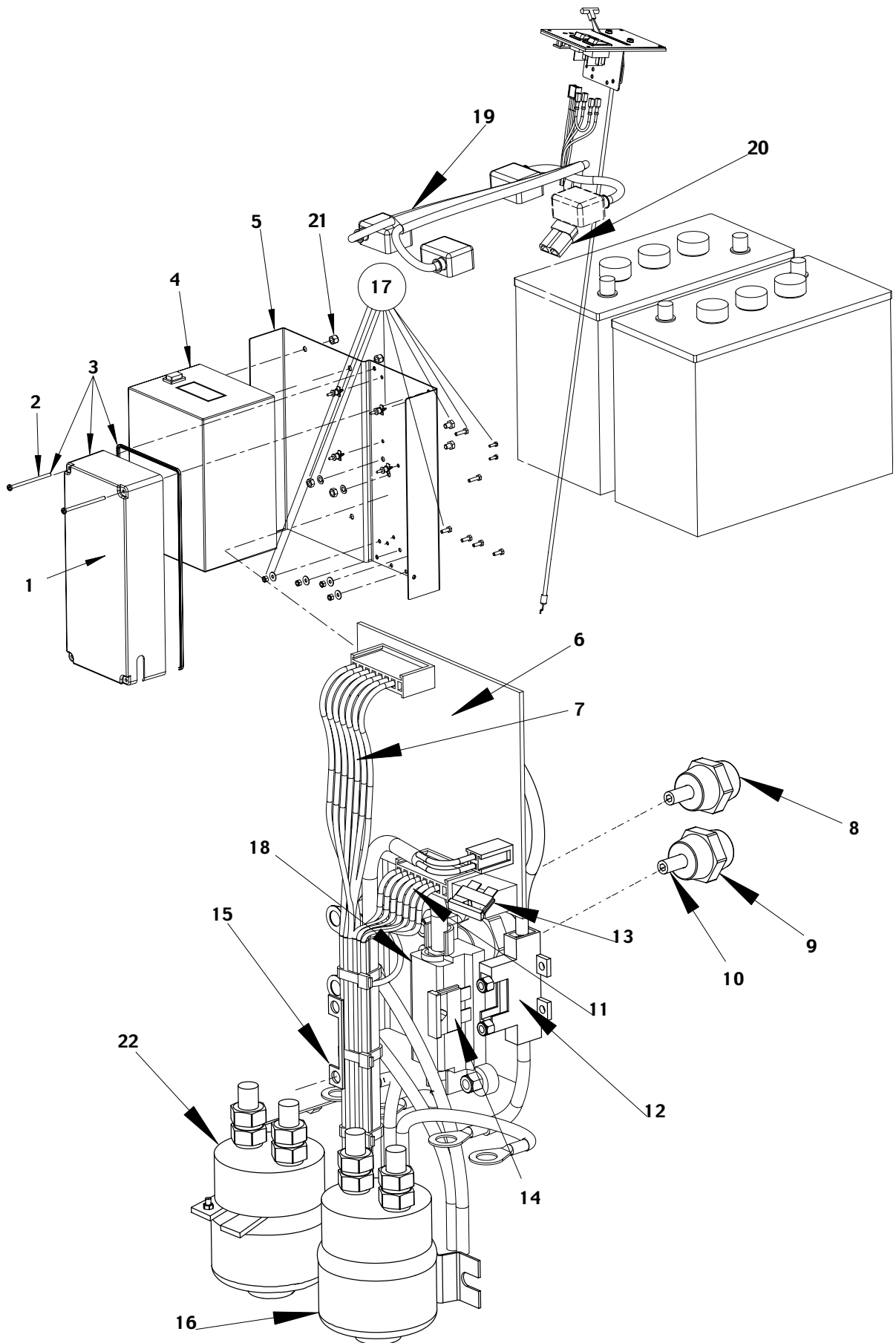

2003-09	WIRING SYSTEM		
	RAZOR 17B/ RAZOR 20B		31

Item no.	Ref. No.	Qty	Description
1#	L08812284	1	Cover
2#	L08812444	2	Screw
3#	L08812625	1	Kit electronic card covering
4#	L08812996	1	Battery charger 24V
5#	L08812890	1	Support
6#	L08812910	1	Electronic card for machines without drive only
6	909 5098 000	1	Electronic card for machine with /without drive
7#	L08812961	1	Machine harness
8	146 0708 000	1	Insulator
9	146 0566 000	1	Insulator
10	146 0759 000	2	Dowel
11#	L08812962	1	Electronic card harness
12	146 0660 000	1	Fuse holder
13	145 9852 000	1	Fuse 5A
14	145 0227 000	1	Fuse 40A
15	145 9854 000	1	Fuse 50A
16	145 0300 000	1	Electromagnetic switch
17#	L08603867	1	Kit electronic card fixing
18	145 8046 000	1	Fuse holder
19#	L08603890	1	Battery harness
20	145 6062 000	1	Battery connector
21	145 9132 000	4	Nut selflocking
22#	L08603934	1	Electromagnetic switch

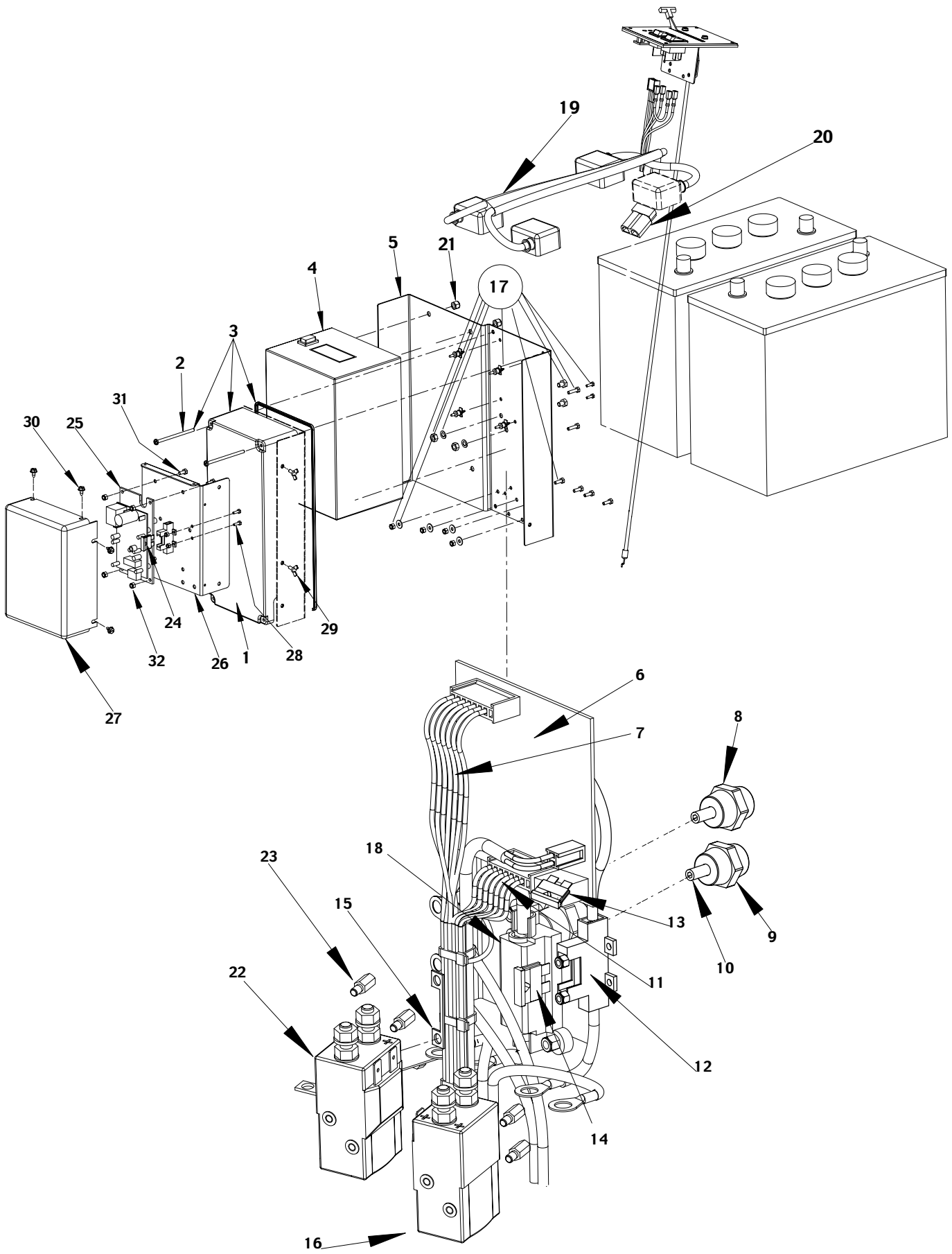

2003-09	WIRING SYSTEM		
	RAZOR 20BT		33

Item no.	Ref. No.	Qty	Description
1#	L08812284	1	Cover
2#	L08812444	2	Screw
3#	L08812625	1	Kit card covering w/screw
4#	L08812996	1	Battery charger 24 V 13A 115V
5#	L08812890	1	Support
6	909 5098 000	1	Electronic card
7	909 5163 000	1	Machine harness
8	146 0708 000	1	Negative insulator
9	146 0566 000	1	Positive insulator
10	146 0759 000	2	Dowel
11	909 5161 000	1	Electronic card harness
12	146 0660 000	2	Fuse holder
13	145 9852 000	1	Fuse 5A
14	145 0227 000	1	Vacuum fuse 40A
15	145 9854 000	1	Brush fuse 50A
16	146 0719 000	1	Vacuum electromagnetic switch
17#	L08603867	1	Kit electr.card fixing
18	145 8046 000	1	Fuse holder
19#	L08603890	1	Battery harness
20	145 6062 000	1	Battery connector
21	145 9132 000	4	Nut selflocking M6
22	909 5127 000	1	Brush electromagnetic switch
23	146 0627 000	4	Spacer
24	145 8513 000	1	Drive fuse 30A
25	909 5110 000	1	Drive electronic card
26	909 5124 000	1	Electronic card support
27	909 5126 000	1	Cover
28#	L08812964	4	Screw hex hd M3x10
29	909 5125 000	2	Screw wing M4x10
30	145 9211 000	4	Screw 3,9x9,5 thd form
31	145 1773 000	4	Screw hex hd M4x10
32	145 5743 000	4	Nut ex.selflock.low M4

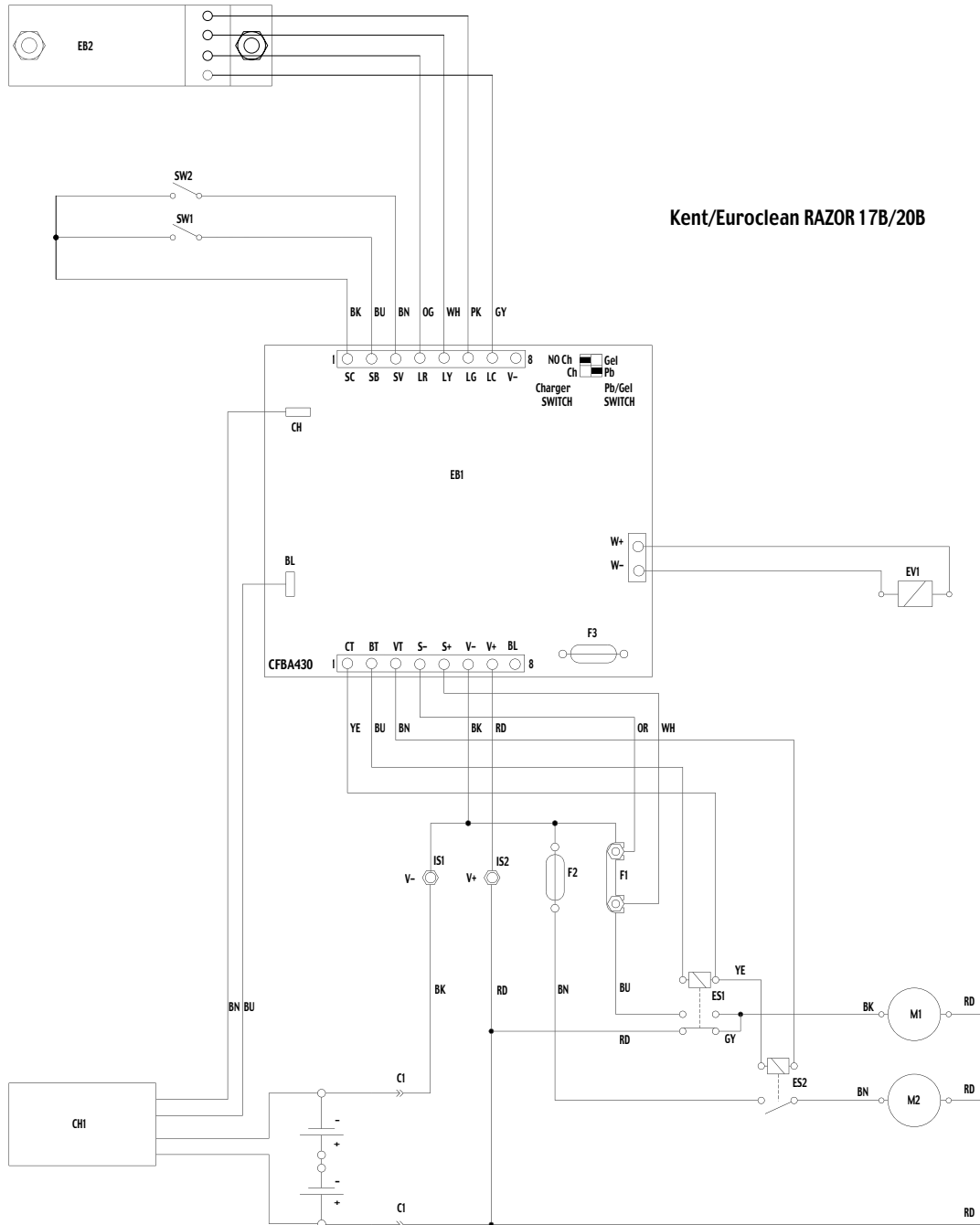

Kent/Euroclean RAZOR 17B/20B

LEGENDA	
CHI	BATTERY CHARGER 08812996
C1	BATTERY CONNECTOR 145 6062 000
EB1	ELECTRONIC CARD (CFBA430) #909 5068 000
EB2	LED BOARD (CFBALED) 08812909
ES1	BRUSH ELECTROMAGNETIC SWITCH 08603934
ES2	VACUUM ELECTROMAGN.SWITCH 145 0300 000
EVI	SOLENOID VALVE 08812960
F1	BRUSH FUSE (50A) 145 9854 000
F2	VACUUM FUSE (40A) 145 0227 000
F3	SOLENOID VALVE & ELECTR. FUSE (5A) 145 9852 000
IS1	NEGATIVE INSULATOR 146 0708 000
IS2	POSITIVE INSULATOR 146 0566 000
M1	BRUSH MOTOR 08812919
M2	VACUUM MOTOR 08603888
SW1	BRUSH SWITCH 08812562
SW2	VACUUM SWITCH 08812562

COLORS CODES		
BK	BLACK	nero
BU	BLUE	azzurro
BN	BROWN	marrone
GN	GREEN	verde
GY	GREY	grigio
OG	ORANGE	arancio
PK	PINK	rosa
RD	RED	rosso
VT	VIOLET	viola
WH	WHITE	bianco
YE	YELLOW	giallo

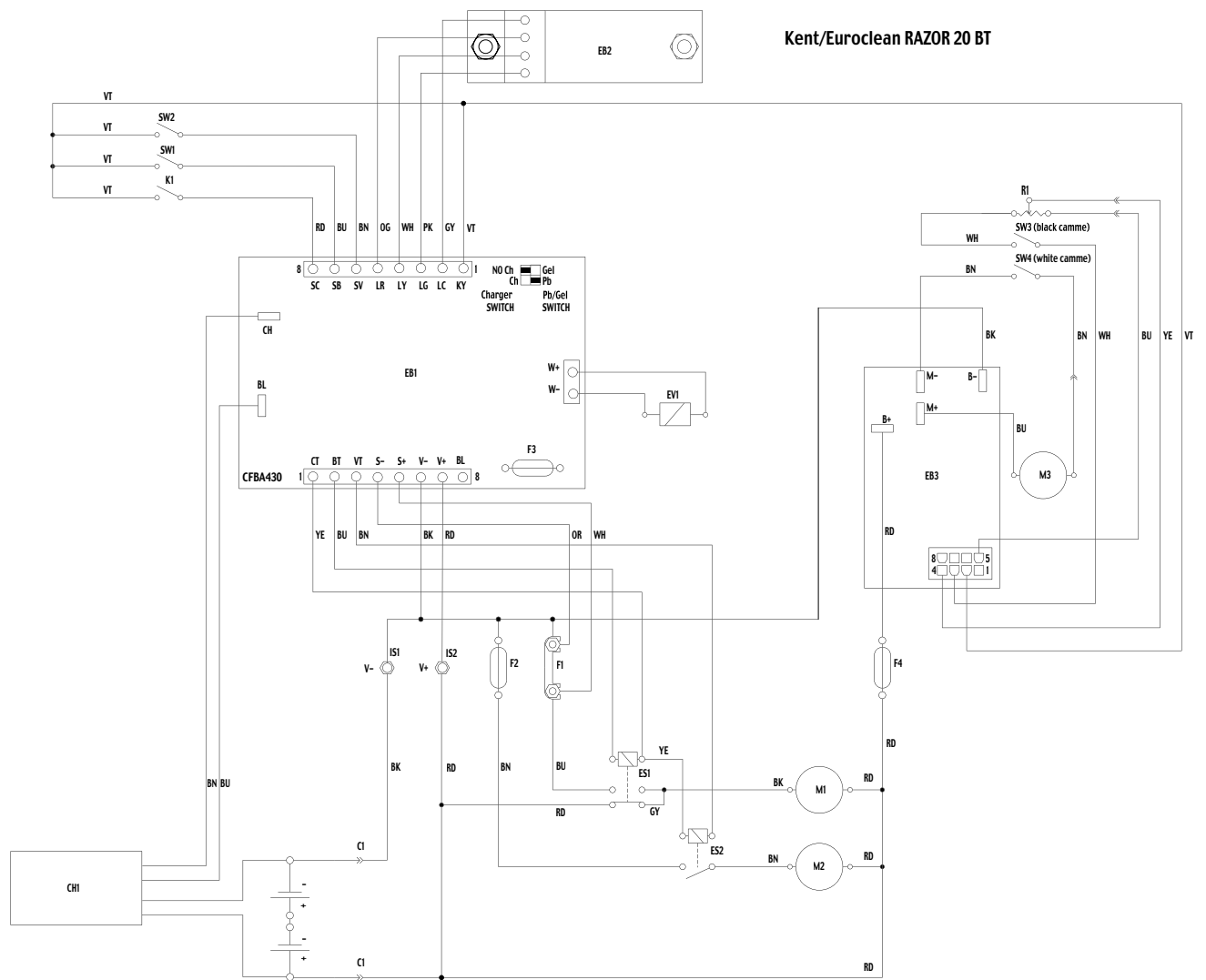

Kent/Euroclean RAZOR 20 BT

LEGENDA

CHI	BATTERY CHARGER 081 2996
C1	BATTERY CONNECTOR 1 45 6062 000
EB1	ELECTRONIC CARD (CFBA430) 909 5098 000
EB2	LED BOARD (CFBALED) 08812909
EB3	DRIVE ELECTRONIC CARD 909 5110 000
ES1	BRUSH ELECTROMGNETIC SWITCH 909 51 27 000
ES2	VACUUM EL. SWITCH 146 0719 000
EV1	SOLENOID VALVE 0881 2960
F1	BRUSH FUSE (50A) 145 9854 000
F2	VACUUM FUSE (40A) 145 0227 000
F3	WATER VALVE & ELECTR. FUSE (5A) 145 9852 000
F4	DRIVE FUSE (30A) 145 8513 000
IS1	NEGATIVE INSULATOR 146 0708 000
IS2	POSITIVE INSULATOR 146 0566 000
K1	KEY SWITCH 145 0372 000
M1	BRUSH MOTOR 0881 2919
M2	VACUUM MOTOR 08603888
M3	DRIVE MOTOR 909 5271 000
R1	SPEED REGULATOR 909 5162 000
SW1	BRUSH SWITCH 0881 2562
SW2	VACUUM SWITCH 0881 2562
SW3	DRIVE CONTROL MICROSWITCH 909 5114 000
SW4	DRIVE MOTOR MICROSWITCH 909 5114 000

COLORS CODES

BK	BLACK	nero
BU	BLUE	azzurro
BN	BROWN	marrone
GN	GREEN	verde
GY	GREY	grigio
OG	ORANGE	arancio
PK	PINK	rosa
RD	RED	rosso
VT	VIOLET	viola
WH	WHITE	bianco
YE	YELLOW	giallo

RECOMMENDED SPARE PARTS

2003-09

36

RAZOR 17B/ RAZOR 20B/ RAZOR 20BT

Item no.	Ref. No.	Qty	Description
			Solution System
	L08603898	1	Solenoid valve kit complete
	L08603808	1	Water filter
	L08603662	1	Hose connection straight
	L08603864	1	Kit rubber holder w/filter
	L08601624	2	Pipe holder
	L08812960	1	Solenoid valve 24V
	L08603958	1	Solution System Hardware Kit
			Tank System
	L08603836	1	Gasket, tank cover
	L08812869	1	Drain hose
	L08812873	1	Solution drain hose complete
	L08603888	1	Kit vacuum motor w/ connector
#	L08603970	1	Squeegee lift lever kit
	L08603868	1	Closure clean water hose
	L08603951	1	Hose fresh water
	L08812930	1	Suction hose
#	909 5042 000	1	Acoustic insulation
	L08812977	1	Acoustic insulation
	L08603860	1	Handle ajuster kit
	L08603956	1	Tank System Hardware Kit
			Brush System
	L08812919	1	Reduction gear motor
	L08219000	1	Vibration damping M8
	L08812213	1	Buffer for brush plate
	L08812203	1	Knob for brush plate
	L08812706	1	Dowel broom plate fixing
	L08603960	1	Brush System Hardware Kit
			Chassis System
	L08603861	1	Kit castor wheel rear
	145 8478 000	1	Pedal cover
	L08603862	1	Kit tank support right
	L08603863	1	Kit tank support left
	L08603957	1	Chassis System Hardware Kit
			Squeegee Assembly
	L08603878	1	Kit squeegee complete
	L08602468	1	Squeegee blade rear
	L08602463	1	Squeegee balde front
	L08812518	1	Adjustment screw kit
	L08603879	1	Kit squeegee wheel
			Control Panel System
	L08812562	1	Kit switch complete
	L08603961	1	Control Panel System Hardware Kit
			Wiring system
#	909 5098 000	1	Electronic card
	L08812996	1	Battery charger 24V
	145 0300 000	1	Electromagnetic switch
	L08603934	1	Electromagnetic switch
	145 9854 000	1	Fuse 50A
	145 0227 000	1	Fuse 40A
	145 9852 000	1	Fuse 5A



KENT
Euroclean

Working For A Cleaner World

Kent/Euroclean
14600 21st Avenue North
Plymouth, MN, 55447-3408
www.kenturoclean.com
Phone: 800-334-1083
Fax: 866-261-4779
©2003 Printed in Italy