



## Electronic Service Manuals

This electronic document is provided as a service to our customers. We do not create the contents of the information contained in this document. Should you have detailed questions pertaining to the information contained in this document, you may contact Michco, or the manufacturer which provided the original information in this electronic deliverable. Michco's only part in this electronic deliverable was the electronic assembly process.

You may contact Michco through the following methods:  
Phone (517) 484-9312 or (800) 331-3339 MI, OH, IN only  
2011 N. High St. -- Lansing, Michigan -- 48906  
Fax: (517) 484-9836  
Email: [CustServ@Michco.com](mailto:CustServ@Michco.com)  
Web site: [www.Michco.Com](http://www.Michco.Com)  
Parts Web site: [www.FloorMachineParts.Com](http://www.FloorMachineParts.Com)

Order Parts on Line at:  
**[www.FloorMachineParts.Com](http://www.FloorMachineParts.Com)**

Directly to Parts & Service:  
By Email: **[Shop@Michco.com](mailto:Shop@Michco.com)**  
By Fax: (517) 702-2041  
By Voice: Use numbers above.

**Serving the Cleaning Industry Since 1922**

Notice: All copyrighted material remains property of original owners, all trademarks are property of respective owners. Manuals are subject to Manufacturer's reproduction limitations. Originals or reproductions were provided by manufacturers through a request. We make no warranty as to the correctness of information provided in this document and you assume all risk.

# EC 1500

---

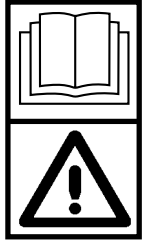

## **OPERATOR MANUAL AND PARTS LIST**

**Euroclean MODEL 56649024**



## IMPORTANT SAFETY INSTRUCTIONS

This machine is only suitable for commercial use, for example in hotels, schools, hospitals, factories, shops and offices other than normal residential housekeeping purposes.

When using an electrical appliance, basic precautions should always be followed, including the following:

Read all instructions before using.

### **WARNING!**

To reduce risk of fire, electric shock, or injury:

- Do not leave the appliance when it is plugged in. Unplug the unit from the outlet when not in use and before servicing.
- This machine is for dry use only and shall not be used or stored outdoors in wet conditions.
- To avoid electric shock, do not expose to rain. Store indoors.
- Do not allow to be used as a toy. Close attention is necessary when used by or near children.
- Use only as described in this manual. Use only manufacturer's recommended attachments.
- Do not use with damaged cord or plug. If appliance is not working as it should, has been dropped, damaged, left outdoors, or dropped into water, return it to a service center.
- Do not pull or carry by cord, use cord as a handle, close a door on a cord, or pull cord around sharp edges or corners. Do not run appliance over cord. Keep cord away from heated surfaces.
- Do not unplug by pulling on cord. To unplug, grasp the plug, not the cord.
- Do not handle plug or appliance with wet hands.
- Do not put any object into openings. Do not use with any opening blocked; keep free of dust, lint, hair, and anything that may reduce air flow.
- Keep hair, loose clothing, fingers, and all parts of body away from openings and moving parts.
- Turn off all controls before unplugging.
- Do not use with flammable or combustible liquids such as gasoline or use in areas where they may be present.
- Use only identical replacement parts.
- This machine is not suitable for picking up health endangering dust.

**SAVE THESE INSTRUCTIONS**

# INSTRUCCIONES DE SEGURIDAD IMPORTANTES

Esta máquina sólo está disponible para su uso comercial en, por ejemplo, hoteles, escuelas, hospitales, fábricas, tiendas y oficinas además de su uso en domicilios particulares.

Al utilizar un electrodoméstico, se deben seguir siempre las precauciones básicas de seguridad, que incluyen lo siguiente:

Leer todas las instrucciones antes de utilizarlo.

## ¡ADVERTENCIA!

Para reducir el riesgo de fuego, descarga eléctrica, o lesiones:

- No dejar el electrodoméstico enchufado. Desenchufarlo cuando no se utilice y antes de realizar en él trabajos de mantenimiento o reparación.
- Esta máquina sólo sirve para ser utilizada en seco y no debe utilizarse o almacenarse en el exterior bajo condiciones de humedad.
- Para evitar descargas eléctricas, no exponer a la lluvia. Almacenar en el interior.
- No permitir su uso como juguete. Es necesario prestar mucha atención cuando sea utilizada por o cerca de los niños.
- Utilizar sólo según las instrucciones del presente manual. Utilizar solamente accesorios recomendados por el fabricante.
- No utilizar con los cables dañados. En caso de no funcionar como debería, o bien si se ha caído, dañado, dejado en el exterior o caído sobre el agua, devolver el electrodoméstico al centro de servicio.
- No tirar o arrastrar el electrodoméstico con el cable, ni utilizar el cable como maneta, o cerrar una puerta pinzando el cable o bien tirar del cable sobre superficies o esquinas angulosas. No pasar el electrodoméstico sobre el cable. Mantener el cable alejado de las superficies calentadas.
- No desenchufar tirando del cable. Para desenchufar se debe tirar del enchufe, no del cable.
- No coger el cable o el electrodoméstico con las manos mojadas.
- No colocar ningún objeto en las salidas. No utilizar cuando alguna salida esté bloqueada; mantenerlas libres de polvo, pelusa, pelos y cualquier cosa que pueda reducir el flujo del aire.
- Mantener los cabellos, ropa suelta, dedos y todas las partes del cuerpo alejadas de las salidas y de las piezas mecánicas.
- Apagar todos los controles antes de desenchufar.
- No utilizar con líquidos inflamables o combustibles como, por ejemplo, la gasolina, ni utilizar en zonas en donde se hallen dichos líquidos.
- Utilizar sólo repuestos idénticos.
- Esta máquina no es adecuada para recoger polvo que ponga en peligro la salud.

**CONSERVE ESTAS INSTRUCCIONES**

# INSTRUCTIONS DE SÉCURITÉ IMPORTANTES

Cette machine ne convient qu'à un usage industriel, par exemple dans des hôtels, écoles, hôpitaux, usines, boutiques et bureaux et autres à l'exclusion de tout usage de maintenance résidentielle normale.

Lors de l'utilisation d'un appareil électrique, des précautions de base doivent toujours être appliquées, incluant celles ci-dessous:

Lisez toutes les instructions avant l'emploi.

## **ATTENTION!**

Pour réduire tout risque d'incendie, de secousse électrique ou de blessure:

- Ne quittez pas l'appareil lorsqu'il est branché. Débranchez l'unité de la prise lorsqu'il n'est pas en fonctionnement et avant toute maintenance.
- Cette machine ne doit être utilisée qu'à sec et ne devra être utilisée ou emmagasinée à l'extérieur par temps humides.
- Pour éviter toute secousse électrique, ne l'exposez pas à la pluie. Emmagazinez le à l'intérieur.
- Ne le laissez pas être manipulé comme un jouet. Une grande attention est nécessaire lorsqu'il est utilisé par ou à proximité d'enfants.
- Ne l'utilisez que comme décrit dans ce manuel. N'utilisez que des attachements recommandés par le fabricant.
- Ne l'utilisez lorsque la prise ou le cordon sont abîmés. Si l'appareil ne fonctionne pas comme il le devrait, est tombé, abîmé, a été laissé à l'extérieur, est tombé dans l'eau, retournez le à un centre de service.
- Ne le tirez ou portez pas par le cordon, n'utilisez pas le cordon comme une poignée, ne fermez pas une porte sur le cordon et ne passez pas le cordon sur des bords ou des coins tranchants. Ne faites pas rouler l'appareil sur le cordon. Gardez le cordon loin de toutes surfaces chauffantes.
- Ne le débranchez pas en tirant sur le cordon. Pour débrancher, empoignez la prise, non le cordon.
- Ne manipulez pas la prise ou l'appareil avec les mains mouillées.
- Ne mettez aucun objet dans les ouvertures. Ne l'utilisez pas lorsqu'une ouverture est bouchée; gardez le à l'abri de la poussière, de la charpie, des cheveux, et de tout ce qui pourrait réduire l'arrivée d'air.
- Gardez les cheveux, les habits amples, les doigts, et toute partie du corps loin des ouvertures et des parties mobiles.
- Eteignez tous les contrôles avant de débrancher.
- Ne l'utilisez pas avec des liquides inflammables ou combustibles comme l'essence ou ne l'utilisez pas dans des endroits où ils pourraient être présents.
- N'utilisez que des pièces de rechange semblables.
- Cette machine n'est pas destinée au ramassage de poussière dangereuse pour la santé.

**CONSERVEZ CES INSTRUCTIONS**

## INTRODUCTION

This manual will help you get the most from your **Euroclean EC 1500**. Read it thoroughly before operating the machine.

This product is intended for commercial use only.

## PARTS AND SERVICE

Repairs, when required, should be performed by your Authorized Euroclean Service Center, who employs factory trained service personnel, and maintains an inventory of Euroclean original replacement parts and accessories.

Call the EUROCLEAN DEALER named below for repair parts or service. Please specify the Model and Serial Number when discussing your machine.

(Dealer, affix service sticker here.)

## NAME PLATE

The Model Number and Serial Number of your machine are shown on the Nameplate on the machine. This information is needed when ordering repair parts for the machine. Use the space below to note the Model Number and Serial Number of your machine for future reference.

MODEL NUMBER \_\_\_\_\_

SERIAL NUMBER \_\_\_\_\_

## UNCRATE THE MACHINE

When the machine is delivered, carefully inspect the shipping carton and the machine for damage. If damage is evident, save the shipping carton so that it can be inspected. Contact the Euroclean Customer Service Department immediately to file a freight damage claim.

## INTRODUCCIÓN

Este manual le ayudará a obtener el máximo rendimiento de su **Euroclean EC 1500**. Léalo por completo antes de poner en funcionamiento la máquina. Este producto sólo está destinado a uso profesional.

## PIEZAS Y SERVICIO

Las reparaciones, cuando sean necesarias, deben ser realizadas por el Centro de Servicio Autorizado de Euroclean, que emplea personal entrenado en fábrica y mantiene un inventario de accesorios y piezas de repuestos originales de Euroclean. Llame al REPRESENTANTE DE EUROCLEAN que se indica más abajo para obtener piezas de repuesto y servicio. Al referirse a su máquina, indique el modelo y número de serie.

(Representante, coloque aquí su pegatina de servicio.)

## PLACA DE DATOS NOMINALES

El número de modelo y el número de serie de su máquina se muestran en la placa de datos nominales que está fijada a la máquina. Esta información es necesaria para pedir piezas de repuesto para la máquina. Utilice el espacio reservado para anotar el número de modelo y el número de serie de su máquina para futuras consultas.

NÚMERO DE MODELO \_\_\_\_\_

NÚMERO DE SERIE \_\_\_\_\_

## DESEMBALAJE DE LA MÁQUINA

Cuando le entreguen la máquina, inspeccione cuidadosamente el cartón de embalaje y la máquina para comprobar que no existen daños. Si existen daños evidentes, guarde el cartón para que se pueda inspeccionar. Contacte inmediatamente con el Departamento de Servicio al Cliente de Euroclean para cumplimentar una reclamación por daños durante el transporte.

## INTRODUCTION

Ce mode d'emploi vous permettra de tirer le meilleur de votre **Euroclean EC 1500**. Lisez le attentivement avant d'utiliser la machine.

Ce produit est destiné à l'usage industriel uniquement.

## PIECES ET ENTRETIEN

Les réparations, lorsque nécessaires, devront être exécutées par votre centre de service Euroclean autorisé, qui emploie du personnel de service formé en usine, et maintient un inventaire de pièces de remplacement originales et d'accessoires d'Euroclean. Appelez le DETAILLANT INDUSTRIEL EUROCLEAN ci-dessous pour toute réparation, pièces ou entretien. Veuillez spécifier le modèle et le numéro de série lorsque vous parlez de votre machine.

(Détaillant, appliquer l'auto-collant de service ici.)

## PLAQUE D'IDENTIFICATION

Le numéro du modèle et le numéro de série de votre machine sont inscrits sur la plaque d'identification sur la machine. Cette information est nécessaire lors de la commande de pièces de réparation pour la machine. Utilisez la place ci-dessous pour inscrire le numéro du modèle et le numéro de série de votre machine pour toute référence future.

NUMERO DU MODELE \_\_\_\_\_

NUMERO DE SERIE \_\_\_\_\_

## DEBALLER LA MACHINE

Lors de la livraison, inspectez attentivement l'emballage de transport et la machine pour tout dommage. Si la détérioration est évidente, conservez l'emballage de transport pour qu'il soit inspecté. Contactez le Bureau du Service Clientèle Euroclean immédiatement pour remplir une réclamation de dommage de fret.

NOTE: Although this model has D.C. motor it is rectified to operate on AC current. Plug the electric cable in to a regular 115 volt 60 Hertz AC outlet. Your new EC 1500 comes complete with driving pad assembly with pad holder attached. This assembly is carefully balanced at factory and should not be removed except when necessary for repair of machine.

The EC 1500 is equipped with 50' of 3-wire cord. If an extension cable is used it must be #12 gauge up to 50'.

**ATTACHING PAD:** The proper diameter pad is 20" although 21" can be used, but greater care must be used not to hit side walls, baseboards or furniture. Attaching the pad is best done by locking handle into vertical position, tilting machine back and placing pad over the bristle face as further explained in previous paragraph. Then lower machine carefully to floor with handle still in vertical position.

Position of handle may be elevated, or lowered according to the height of operator by adjusting the height adjusting screw at the base of handle. Loosen nut, adjust screw to desired height and retighten nut.

#### TO OPERATE MACHINE:

Now lower handle by pressing foot release first. Handle will now float up or down until it rests on stop at base of machine. You are now ready to press momentary safety switch at left or right side of handle, but before doing so, it is advisable to slightly press down on handle to relieve floor pressure only for a moment just before squeezing switch levers. Operating height of handle may be adjusted by lowering or raising the handle adjusting screw. First loosen nut and tighten when screw is set.

**PAD LEVEL:** The machine is factory adjusted to be fairly level with floor when using pads 7/8"-1" thick. The pad load is approximately 6 lbs., with a pad speed of 1100 R.P.M. DO NOT ADJUST TO ACCOMMODATE ANY OTHER SIZE PAD.

**NORMAL OPERATION ON FLOOR:** Machine is designed to operate in a straight forward walk method and NOT from side to side as is a standard rotary floor machine. As you will notice, the wheels are in contact with the floor at all times. The machine can be operated in a forward and backward motion when space or nature of area require same. **NEVER OPERATE OR TURN ON MACHINE WHEN HANDLE IS IN VERTICAL POSITION.**

When machine is idle during working period or storage, put handle in vertical lock position and tilt machine back until rear wheels are resting on floor. Disconnect electric cord from wall socket until ready to work again.

#### USE OF FLOOR TREATMENT CHEMICALS:

The EC 1500 is specifically designed for spray buffing. Spray material must be sprayed well in front of machine preferably with a hand held and hand operated spray bottle. Spraying too close to machine with a machine mounted spray unit will be wasteful as it sprays too close to brush area, which by reason of speed, creates a substantial breeze preventing proper application of chemical spray. As of this writing experimenting is in progress regarding possibilities of scrubbing and dri-stripping with Ultra Hi-Speed Machines.

**TYPES OF PADS:** Best results will be obtained with synthetic pads such as polyester or nylon. A commonly used pad made by most manufacturers is the so-called "red" buffer pad and the "white" super polish pads. Light cleaning can be done with the light scrub pads commonly available. The Hi-Speed gold pads are excellent.

Be sure to reverse sides of pad as soon as they become clogged and change pads frequently. (Used pads should be immediately soaked in a tub of water for subsequent cleaning out by washing and wringing for re-use.)

**BRUSH DRIVE:** Maintain "V" Belt tension by loosening motor mounting bolts slightly and re-positioning motor. Do Not over-stretch belt as this will cause grinding noise and eventually ruin bearings.

**MOTOR:** Motor brushes, when operated under normal conditions, will have an operating life of greater than 2000 hours; however, it is advisable to check the brushes after each 1000 hours of operation. Brushes should be changed when brush spring reaches the "stop" on the brush holder.

**LUBRICATION:** None needed except occasional drop on wheel bearings. Clean any excess oil off wheel treads.

**LIMITED WARRANTY :** This machine is warranted to be free of defects in workmanship or materials for a period of one (1) year. Liability under warranty is limited to replacing or repairing any part or parts which prove defective. No warranty express or implied other than above is made or authorized by Euroclean, Inc.

Specifically not covered by this warranty though not limited hereby, is the misuse, negligence, accident, or unauthorized alteration or repair to which the machine may be subjected.

## WARNING:

1. To avoid electric shock, do not expose to rain. Store indoors.
2. Use the grounding feature provided by 3 wire cable.
3. If 3-2 prong adapters are used, follow adapter instructions carefully.

## SAFETY INSTRUCTIONS

### Grounding Instructions

This appliance should be grounded while in use to protect the operator from electric shock. The appliance is equipped with an approved three-conductor cord and three-prong grounding-type receptacle. The green conductor in the cord is the grounding wire. Never connect the green wire to a live terminal. If your unit is for use on less than 150 volts, it has a plug as show in Sketch A. An adapter shown in sketch B, is available for connecting plugs as shown in B to two-prong receptacles. The green-colored rigid ear, lug, etc., must be connected to a permanent ground such as a properly grounded outlet box.

### Extension Cords

Use only three-wire outdoor extension cords that have three-prong grounding-type and three pole receptacles that accept the appliance's plug. Replace or repair damaged cords. If an extension cable is used it must be #12 gauge up to 50'.

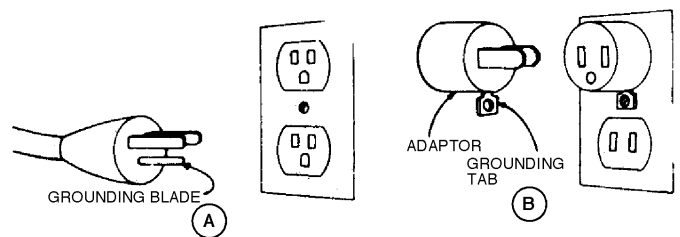

### REMEMBER . . .

- 1: Plug into AC outlet only-15 Amp minimum, but 20 Amps preferable.
2. Do not re-adjust wheels to accommodate any other than 7/8"-1" thick pads.
- 3: Use machine only in forward and backward direction. Some angular movement is easily achieved.
4. Do not remove driving pad assembly unless changing belt.

## WARNING

When motor brush warning light is lit (on motor canopy), motor brushes must be replaced within 20 hours of service to prevent damage to motor. **RISK OF EXPLOSION** -Floor sanding can result in an explosive mixture of fine dust and air. Use floor sanding machine only in well ventilated area. **TO AVOID ELECTRIC SHOCK DO NOT EXPOSE TO RAIN - STORE INDOORS.**

## 120VAC GROUNDING INSTRUCTIONS

This appliance must be grounded. If it should electrically malfunction, grounding provides a path of least resistance for electric current to reduce the risk of electric shock. This appliance is equipped with a cord having an equipment-grounding conductor and grounding plug. The plug must be plugged into an appropriate outlet that is properly installed and grounded in accordance with all local codes and ordinances.

### **⚠ DANGER!**

Improper connection of the equipment-grounding conductor can result in a risk of electric shock. Check with a qualified electrician or service person if you are in doubt as to whether the outlet is properly grounded. Do not modify the plug provided with the appliance. If it will not fit the outlet, have a proper outlet installed by a qualified electrician.

This appliance is for use on a nominal 120-volt circuit, and has a grounding plug that looks like the plug illustrated in Figure 1 below. A temporary adapter illustrated in Figures 2 and 3 may be used to connect this plug to a 2-pole receptacle as shown in Figure 2 if a properly grounded outlet is not available. The temporary adapter should be used only until a properly grounded outlet (Figure 1) can be installed by a qualified electrician. The green-colored rigid ear, tab, or the like extending from the adapter must be connected to a permanent ground such as a properly grounded outlet box cover. Whenever the adapter is used, it must be held in place by a metal screw. Grounding adapters are not approved for use in Canada.

Replace the plug if the grounding pin is damaged or broken.

The Green (or Green/Yellow) wire in the cord is the grounding wire. When replacing a plug, this wire must be attached to the grounding pin only.

Extension cords connected to this machine should be 12 gauge, three-wire cords with three-prong plugs and outlets. DO NOT use extension cords more than 50 feet (15 m) long.

#### PLEASE NOTE: FOR NORTH AMERICA ONLY

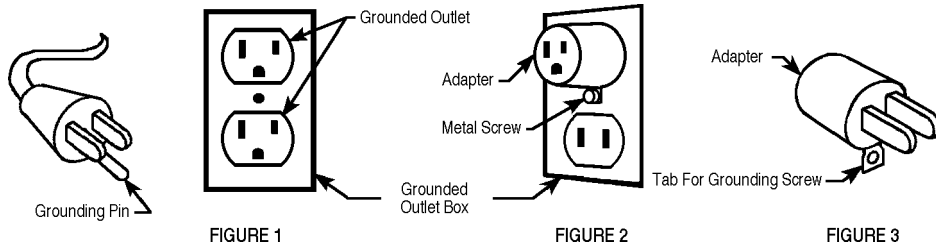

## 120VAC INSTRUCCIONES PARA HACER LA TOMA A TIERRA

Este aparato deberá ser conectado a tierra. En caso de malfuncionamiento o de desperfectos, la toma a tierra proporciona una vía de menor resistencia de la corriente eléctrica para reducir el riesgo de choques eléctricos. Esta unidad viene equipada con un cordón con conductores para toma a tierra y con un enchufe con toma a tierra. Ese enchufe deberá ser enchufado a un receptáculo en buen estado con instalación a tierra según los códigos y ordenanzas de la zona.

### **⚠ ¡PELIGRO !**

Si el conductor a tierra no está instalado correctamente pueden producirse riesgos de choques eléctricos. En caso de duda, consulte con un electricista o personal de servicio autorizados. No modifique el cordón provisto con el aparato. Si no calza en el receptáculo, llame a un electricista calificado para que coloque un receptáculo adecuado.

Este aparato se usa con un circuito de 120-voltios nominales, y tiene un enchufe con toma a tierra tal como se muestra en la figura 1, a continuación. Se puede usar un adaptador provisorio tal como se ve en las figuras 2 y 3 en caso de disponerse de un receptáculo sin toma a tierra como en la figura 2. Dicho adaptador provisorio se usará solamente hasta que un electricista calificado instale un receptáculo con la toma a tierra correspondiente (figura 1). La lengüeta de conexión de color verde que sale del adaptador deberá ser conectada a una toma a tierra permanente como, por ejemplo, la caja del receptáculo con toma a tierra. Siempre que se use el adaptador, hay que sostenerlo en su lugar con un tornillo de metal.

Sustituya el enchufe si la patilla de tierra está dañada o rota.

El hilo verde (o verde/amarillo) del cordón es el hilo de tierra. Cuando sustituya el enchufe, este hilo sólo debe ir conectado a la patilla de tierra.

Los cables alargadores conectados a esta máquina deben ser del calibre 12, trifilares, con tres patillas y tomas de pared adecuadas. NO UTILICE cables alargadores de más de 15 m.

#### ATENCIÓN : PARA AMÉRICA DE NORTE SOLAMENTE.

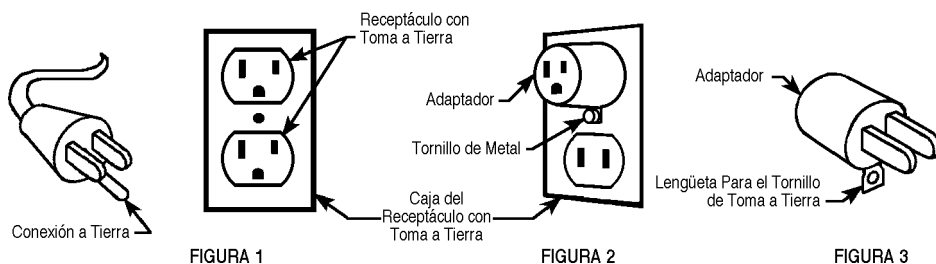

## INSTRUCTIONS VISANT LA MISE À LA TERRE (120VAC)

Cet appareil doit être mis à la terre. En cas de défaillance ou de panne éventuelles, la mise à la terre fournit au courant un chemin de moindre résistance qui réduit le risque de choc électrique. Cet appareil est pourvu d'un cordon muni d'un conducteur de terre et d'une fiche avec broche de terre. La fiche doit être branchée dans une prise appropriée correctement installée et mise à la terre conformément aux règlements et ordonnances municipaux.

### **⚠ AVERTISSEMENT !**

Un conducteur de terre mal raccordé peut entraîner un risque de choc électrique. Consulter un électricien ou un technicien d'entretien qualifié si vous n'êtes pas certain que la prise est correctement mise à la terre. Ne pas modifier la fiche fournie avec l'appareil - si elle ne peut être insérée dans la prise, faire installer une prise adéquate par un électricien qualifié.

Cet appareil est destiné à un circuit de 120 V et est muni d'une fiche de terre semblable à celle illustrée par le croquis 1. Un adaptateur temporaire semblable à celui illustré par le croquis 2 et C peut être utilisé pour brancher cette fiche à une prise bipolaire comme l'illustre le croquis 2 si une prise avec mise à la terre n'est pas disponible. L'adaptateur temporaire devrait être utilisé seulement jusqu'à ce qu'une prise avec mise à la terre soit installée par un électricien qualifié. L'oreille rigide ou le crochet ou autre dispositif semblable, de couleur verte, prolongeant l'adaptateur doit être raccordé à un élément correctement mis à la terre comme le couvercle d'une boîte de sortie mise à la terre. L'adaptateur doit être fixé par une vis métallique. **Note:** Au Canada, l'utilisation d'un adaptateur temporaire n'est pas autorisée par le Code canadien de l'électricité.

Remplacez la prise si la prise de terre est abîmée ou cassée.

Le fil Vert (ou Vert/Jaune) dans la gaine est le fil de terre. Lors du remplacement d'une prise, ce fil doit être raccordé à la prise de terre uniquement.

Les rallonges connectées à cette machine doivent avoir 12 mesures, trois ganses de fil ayant **trois fiches masculines féminines tree-prong plugs and outlets**. N'UTILISEZ PAS de rallonge de plus de 15 m (50 pieds) de long.

**VEUILLEZ NOTER: CES INSTRUCTIONS CONCERNENT UNIQUEMENT L'AMÉRIQUE DU NORD**

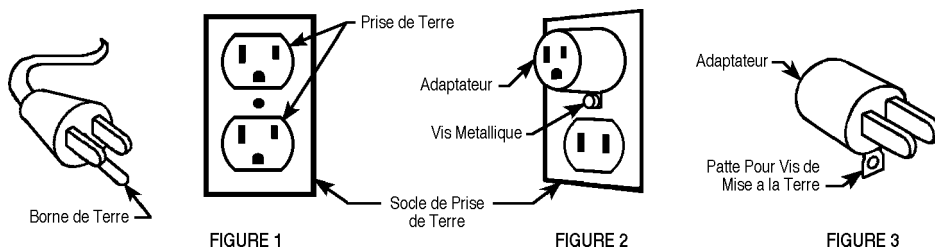

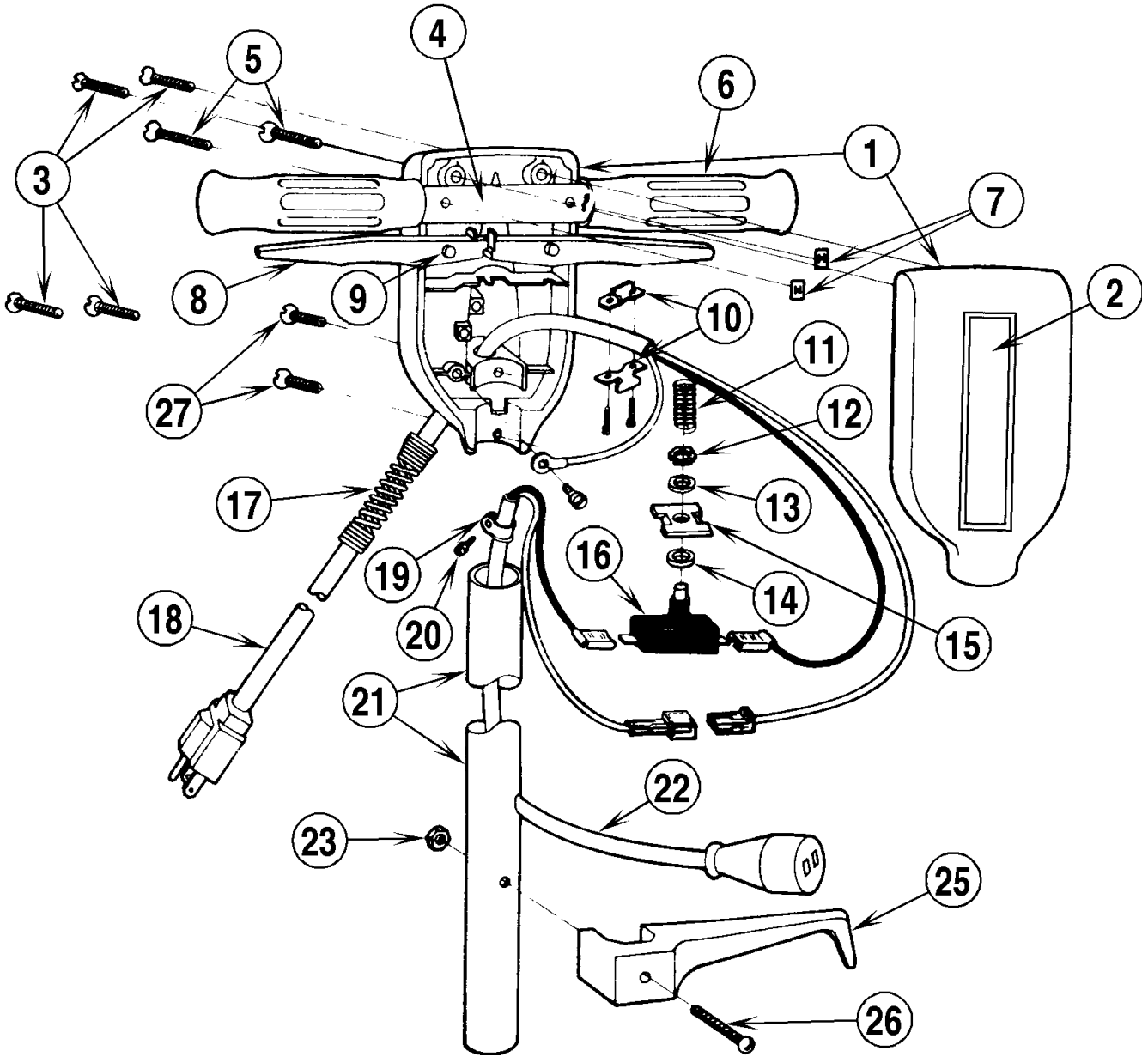

02-6	<b>HANDLE ASSEMBLY</b>		
02-7	<b>EC 1500</b>		<b>11</b>

Item	Ref. No.	Description
	56649485	Handle Assembly with cable, 50', 14 x 3
	56649484	Handle Assembly without cable
1	56649486	Switchbox Assembly <b>NOTE</b>
2	56649749	Decal, EC 1500
3	56649000	Switchbox Screw
4	56649489	Handle Bar
5	56649001	Handle Bar Screw
6	56649497	Handle Grip
7	56649490	Handle Bar Nut
8	56649487	Switch Lever
9	56649488	Lever Pivot Pin
10	56649509	Strain Relief
11	56649504	Coil Spring
12	56649507	Switch Nut
13	56649508	Washer
14	56649332	Washer
15	56649505	Switch Bracket
16	56649506	Switch
17	56649498	Cable Spring
18	56649605	Cable Assembly
19	56649502	Strain Relief (tube wire)
20	56649004	Strain Relief Screw
21	56649493	Handle Tube
22	56649503	Tube Wire Assy
23	56649492	Cable Hook Nut
25	56649495	Cable Hook
26	56649765	Cable Hook Screw
27	56649013	Switchbox Screw

**NOTE:** Individual tops and bottoms cannot be ordered separately, this assembly includes 4 #56649000 screws.

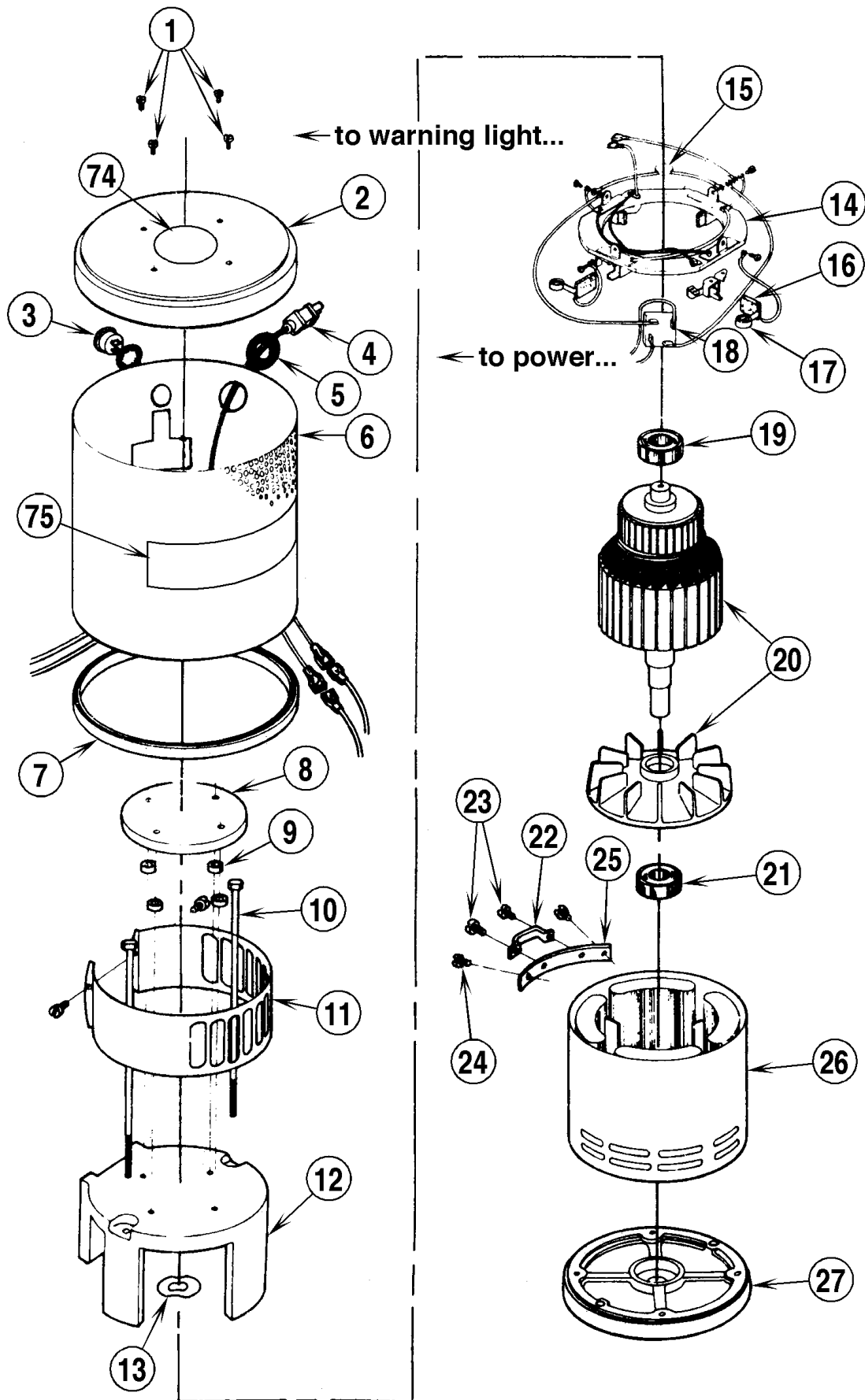

02-6	<b>MOTOR ASSEMBLY</b>			
02-7	<b>EC 1500</b>			<b>13</b>

**Item Ref. No. Description**

NOTE: FOR IMPERIAL ELECTRIC MOTOR, USE:

	56649665	Motor Assembly <b>NOTE</b>
1	56649006	Screw
2	56649373	Motor Canopy
3	56649401	Brush Wear Light
4	56649391	Motor Lead
5	56649381	Grommet
6	56649403	Perforated Motor Cover
7	56649453	Motor Cover Gasket
8	56649399	Canopy Gasket
9	56649400	Canopy Spacer
10	56649388	Thru Bolt
11	56649387	Brush Band Cover
12	56649389	Top End Bell
13	56649390	Helical Washer
14	56649402	Brush Board Assy
15	56649510	Varistor
16	56649393	Motor Brush
17	56649392	Motor Brush Spring
18	56649669	Rectifier
19	56649394	Upper Bearing
20	56649396	Armature W/Fan
21	56649397	Lower Bearing
22	56649372	Hook Bracket
23	56649007	Hook Bracket Screw
24	56649008	Hook Bracket Mtg. Screw
25	56649385	Hook Bracket Mount
26	56649395	Field Assy
27	56649398	Lower End Bell
74	56649755	Decal, Logo
75	56649754	Decal, Euroclean

**NOTE:** Latest version can be substituted for all prior complete units.

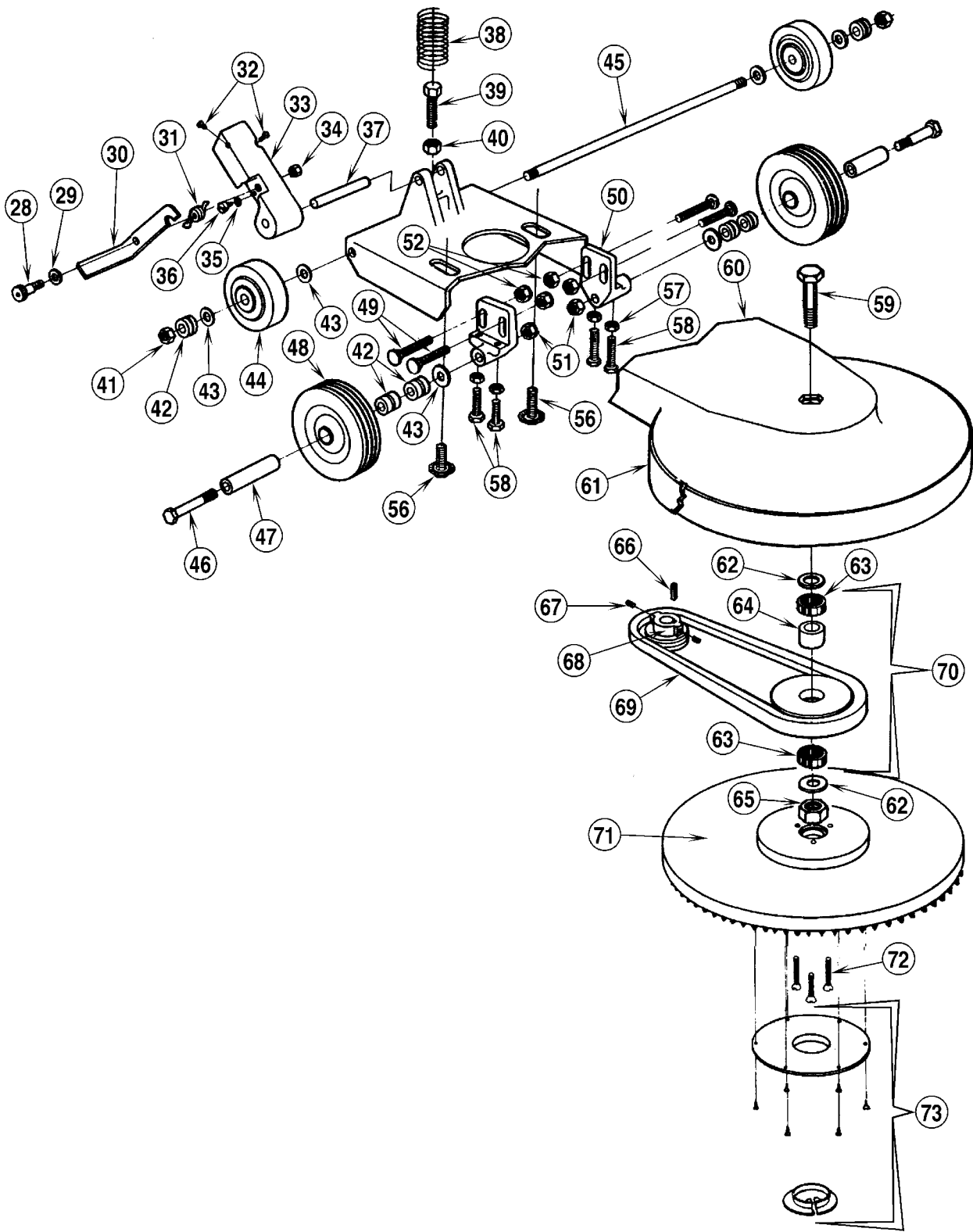

Item	Ref. No.	Description
28	56649298	Lever Pivot
29	56649332	Washer
30	56649370	Latch Lever
31	56649371	Latch Lever Spring
32	56649277	Set Screw
33	56649369	Handle Adapter
34	56649353	Nut
35	56649333	Grommet
36	56649406	Latch Spring Screw
37	56649345	Pivot Pin
38	56649511	Handle Adj. Spring
39	56649456	Handle Adj. Screw
40	56649352	Nut
41	56649293	Nut
42	56649292	Spacer
43	56649339	Washer
44	56649301	Wheel
45	56649382	Rear Axle
46	56649457	Front Axle
47	56649358	Wheel Bushing
48	56649355	Wheel
49	56649009	Wheel Bracket Mtg. Bolt
50	56649379	Wheel Bracket
51	56649293	Nut
52	56649492	Nut
56	56649039	Motor Mtg. Bolt
57	56649278	Nut
58	56649608	Wheel Bracket Adj. Bolt
59	56649374	Spindle
60	56649368	Apron
61	56649405	Bumper
62	56649375	Washer
63	56649377	Ball Bearing
64	56649376	Brush Pulley Spacer
65	56649384	Brush Spindle Nut
66	56649378	Key
67	56649609	Set Screw
68	56649380	Motor Pulley
69	56649386	Belt
70	56649383	Brush Pulley Assy <b>NOTE</b>
71	56649363	Driving Pad Assy
71A	56649364	Driving Pad Face
72	56649407	Driving Pad Mtg. Bolt
73	56649610	Pad Holder Assy
*	56388354	Pad, Burnishing 20" (case of 5)

**NOTE:** Brush Pulley supplied only as assembly with bearings.



Kent/Euroclean  
14600 21st Avenue North  
Plymouth, MN, 55447-3408  
[www.eurocleanusa.com](http://www.eurocleanusa.com)  
Phone: 800-334-1083  
Fax: 866-261-4779