



Electronic Service Manuals

This electronic document is provided as a service to our customers. We do not create the contents of the information contained in this document. Should you have detailed questions pertaining to the information contained in this document, you may contact Michco, or the manufacturer which provided the original information in this electronic deliverable. Michco's only part in this electronic deliverable was the electronic assembly process. By providing this manual on line we are not guaranteeing parts availability.

You may contact Michco through the following methods:

Phone (517) 484-9312 or (800) 331-3339

2011 N. High St. -- Lansing, Michigan -- 48906

Fax: (517) 484-9836

Email: CustServe@Michco.com

Web site: www.Michco.Com

Parts Web site: www.FloorMachineParts.Com

Order Parts on Line at:

www.FloorMachineParts.Com

Directly to Parts & Service:

By Email: **Shop@Michco.com**

By Fax: (517) 702-2041

By Voice: Use numbers above.

Serving the Cleaning Industry Since 1922

Notice: All copyrighted material remains property of original owners, all trademarks are property of respective owners. Manuals are subject to Manufacturer's reproduction limitations. Originals or reproductions were provided by manufacturers through a request. We make no warranty as to the correctness of information provided in this document and you assume all risk. By placing these manuals on line we are not declaring our corporation to be an manufacturer authorized dealer or provider, please check our web site for authorized manufacturers we represent.



IPC Eagle

OPERATIONS MANUAL & PARTS LIST

SC7
Fastracts Extractor



BEFORE OPERATING THE MACHINE

Read the manual carefully and completely before attempting to operate the unit. This manual has important information for the use and safe operation of the machine. Keep this manual handy at all times. This machine will ensure years of satisfactory service if operated and maintained according to recommendations in the manual. If additional information is needed, please contact your local distributor or write to:

IPC Eagle
3650 Dodd Rd
Eagan, MN 55123

All information and specifications printed in the manual and parts list are current at the time of printing; however, because of Eagle Power's policy of continual product improvement, we reserve the right to make changes at any time without notice.

This machine is shipped with antifreeze in the solution line system to protect the pump and valves from freezing during transport and storage. Before you use the unit, rinse the solution line system with clean water (See Preparing The Machine).

WARNING

- The machine was designed for use on carpet and upholstery extraction application as per instructions and recommendations written in this manual. Any deviation from its proper use or purpose and the consequential damage that may occur is the sole responsibility of the end user.
- Disconnect the power cord from outlet before servicing. Do not leave machine connected to an electrical outlet when unattended.
- Do not immerse or use this machine in standing water. Such use may cause electric shock.
- This equipment is not designed to handle or use combustible/volatile substance such as gasoline or kerosene, in, on, or near the machine. The use of such materials will cause an extreme hazard condition.
- When using an extension cord, use only a 3 conductor grounding cord-12 ga. wire or heavier.
- To avoid electric shock, do not expose the unit to rain-store it indoors only.
- Do not use the machine for dry vacuuming. This machine is not outfitted with a fine dust filter and it will damage the vacuum motor(s).

- Use defoamer at all times to prevent damage to the vacuum motor(s).
- Do not use water in excess of 140°F (62°C).
- Use only commercially available carpet cleaners and defoamer intended for use with machines of this type. Do not use dyes, bleaches, ammonia or other additives. The use of powdered cleaning solution if not diluted properly made result in damage to the pump.
- Do not expose machine to freezing temperatures.
- All repairs must be done by an authorized Eagle Power repair station.
- Do not use replacement parts other than those specified in the parts list.

FAILURE TO COMPLY WITH THE ABOVE WARNING INSTRUCTIONS WILL VOID THE WARRANTY.

GROUNDING INSTRUCTIONS

The 120 V. A/C model has been outfitted with the appropriate grounded connectors. Make sure the machine is connected to a grounded outlet having the same configuration as the grounded plug. No adapter should be used with this machine. Any modification to the connectors will void the warranty.

PREPARING THE MACHINE

1. Rinse then fill the recovery pail with clean hot tap water (not to exceed 140°F). When pouring water, make sure drain hose is clipped in the upright position. Pour the water into the solution tank.
2. Add recommended amount of cleaning solution to the tank, follow mixing directions on label for best results.
3. Set the recovery pail back in place. Add recommended amount of defoamer to the recovery pail. Close the lid.

TO CLEAN CARPET

1. Connect machine to a grounded electrical outlet.
2. Turn on the VACUUM, PUMP and BRUSH switches.
3. Lift up on the handle grips to insure that the front of the machine rests on the carpet. Slowly pull the machine backwards while pressing on the carpet spray switch (below the left handle grip). Monitor the extraction process through the vacuum lid. Release the spray switch 6 inches before ending the stroke.

NOTE: If dirty solution does not appear through the vacuum lid check to be sure if:

- The vacuum lid is resting properly on the recovery pails
- The machine's nose is touching the carpet in the working mode.
- The solution tank is not empty.

4. Roll the machine forward on its four wheels for next stroke. Make overlapping passes to prevent streaking. Check solution level from time to time (see solution indicator tube on rear left corner of the back).

NOTE: If foam appears on vacuum lid, turn the VACUUM SWITCH OFF IMMEDIATELY. Add more defoamer to the recovery pails to dissolve foam or empty the recovery pails.

5. When the solution tank runs empty, turn off the vacuum, pump and brush switches. Empty the recovery pail and rinse thoroughly. Then repeat steps on PREPARING THE MACHINE.

TO ATTACH ACCESSORY HOSE

1. Remove 2" hose adapter connection from machine.
2. Attach 1 1/2" assembly with adapter plate to vacuum lid inlet.
3. Pull back female quick disconnect sleeve on the machine and insert male plug on the solution hose.

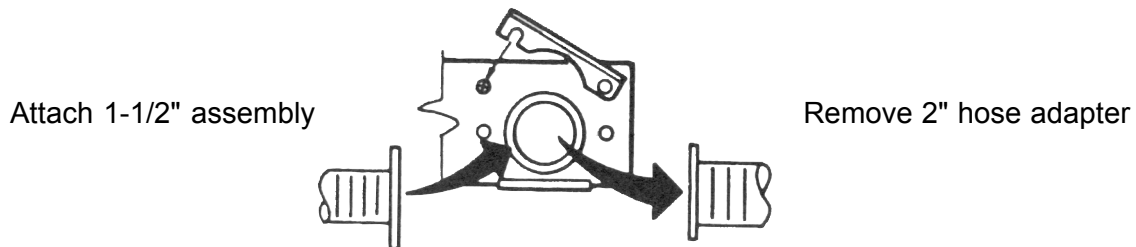

TO EMPTY THE SOLUTION TANK

1. Unhook the drain nozzle (located on the side of the machine from the drain clips), placing the end of the hose into the recovery pail.

AFTER EACH USE

- Empty and thoroughly rinse the recovery pail.
- Coil power cord onto the cord wrap.
- Remove dirt and lint build-up inside vacuum lid filter screen.
- Clean solution line filter.
- Wash the vacuum lid with a soap solution and sponge to prevent dirt from accumulating on the surface. (To avoid scratching use soft cloth only).
- Lean the machine back on its 4 wheels during storage or when it's not in use to prevent brush distortion.)

MAINTENANCE

The upright extractor is engineered for minimum maintenance. But it does require some care to keep it in optimum working condition. Careful attention to these maintenance instructions will give you maximum operating performance and life expectancy of the machine.

- Solution line, fittings and accessory tools. -Flush the machine and accessories at least once a month with solution of 1 part water to 3 parts white vinegar to neutralize the alkaline residue left by the cleaning solution.
- Filter Solution screen. -Unscrew bowl and rinse screen in running tap water. If screen is clogged up with soap, soak in vinegar solution and brush clean.
- Vacuum lid screens. -Always keep the screen clean in order to maintain maximum suction and airflow performance from the vacuum motor. The screens also prevent lint from accumulating in the vacuum motor fan chamber thus increasing the productive life of the motor. Do not operate the unit without the screen installed! If the screen gets lost or damaged, replace it immediately.
- Quick disconnect coupler. -Spray with lubricant (WD-40) or equivalent to prevent coupler from sticking.

TROUBLESHOOTING

ELECTRICAL SYSTEM

PROBLEM	POSSIBLE CAUSE
No electrical power.	1. Defective power cord. 2. House or building circuit breaker trips.
Switch is turned on. Power is intermittent to motor.	1. Faulty electrical cable. 2. Defective Switches. 3. Loose terminal or discolored terminal connections.

VACUUM SYSTEM

PROBLEM	POSSIBLE CAUSE
No Vacuum	1. Vacuum lid is not resting on recovery pail. 2. Loose vacuum hose, vacuum connection.
Low Vacuum	1. Accumulated dirt on lid screen. 2. Worn out vacuum lid gasket. 3. Lint & dirt build-up on suction head. (brush chamber). 4. Defective vacuum hose. 5. Loose connection in the vacuum motor.

SOLUTION SYSTEM

PROBLEM	POSSIBLE CAUSE
Pump motor on, no spray thru carpet spray tips or accessory tool	<ol style="list-style-type: none"> 1. Clogged spray tips. 2. Clogged solution intake filter screen. 3. Clogged solenoid valve or open solenoid coil. 4. If carpet spray works normally, plugged up female quick disconnect coupler. 5. Punctured pump diaphragm 6. Defective pump check valve. 7. Crack in pump housing. 8. Debris in check valve.
Uneven or weak spray from tips.	<ol style="list-style-type: none"> 1. Clogged or dirty spray tips. 2. Accumulated dirt on solution intake filter screen. 3. Accumulation of debris inside pump and plumbing. 4. Worn pump bearing (excessive noise). 5. Punctured pump diaphragm. 6. Defective rectified
Carpet spray is turned off solution still drips from spray tips.	<ol style="list-style-type: none"> 1. Debris caught in between the 3 solenoid valve parts and the plunger.
Vacuum motor working pump motor fails to turn on.	<ol style="list-style-type: none"> 1. Loose "Molex" plug connector. Loose wiring connection. 2. Defective pressure switch in pump motor (100 psi model). 3. Defective pump motor or rectifier.
ROTARY BRUSH SYSTEM	
PROBLEM	POSSIBLE CAUSE
Motor runs, brush won't spin. Brush motor fails to turn on after circuit breaker has been reset.	<ol style="list-style-type: none"> 1. Loose pulley tension. 2. String caught between walls. 1. Defective bridge rectifier. 2. Defective motor.
Floating brush won't move up and down.	<ol style="list-style-type: none"> 1. Debris caught inside the slide block guide.

BRUSH DRIVE BELT SERVICE AND/OR REPLACEMENT (refer to parts diagram).

1. Remove 2 1/4-20 hex screws attaching lower frame to upper frame.
2. Remove (2) spring cover plate assemblies and carefully remove springs from the slide blocks.
3. Loosen (2) 1/4-20 hex screws that hold brush motor bracket in place. Push bracket toward the front of the machine to loosen belt.
4. Remove right Open-End and left Pulley-End cover plates.
5. Slide brush assembly and slide blocks out from their guides. Replace worn and defective belt.
6. Reinstall above components. Clean accumulated lint or debris inside the slide block guides and check for wear on the teflon surfaces. Replace if necessary. The slide block washer (item #36) must be installed between the slide block guide and inside the divider wall. Adjust belt tension by moving motor bracket toward the rear. Apply minimum belt tension when the hex bolts are tightened to allow for a smooth vertical brush movement. A belt too loose will cause the belt to skip when brush is applied on the carpet. A belt too tight won't allow for up and down movement.

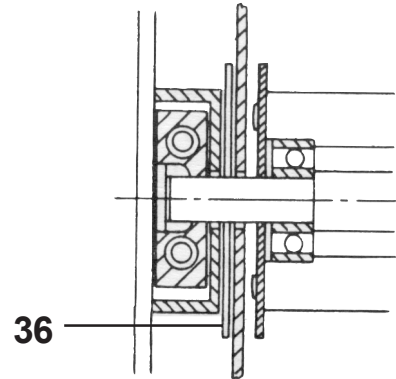

REPLACEMENT OF BRUSH ASSEMBLY AND/OR BEARINGS

1. Repeat steps 1 thru 4.
2. Remove slide blocks from the ends of the brush shaft.
3. Remove (4) screws from string guard. Tap the shaft toward the right open end to remove the bearing.
4. Remove (4) screws from slinger and pull off brush core. Scrape off old sealant build up on the slinger and string guard. It is advisable to replace the two bearings every time the brush is replaced.
5. Reinstall the above component. CAUTION! Install shorter step on the shaft ends toward the left pulley side. Apply silicon sealant such as GE Silicon auto seal onto the ends of the brush core before reassembling the slinger and string guard.

Fastracts SC7

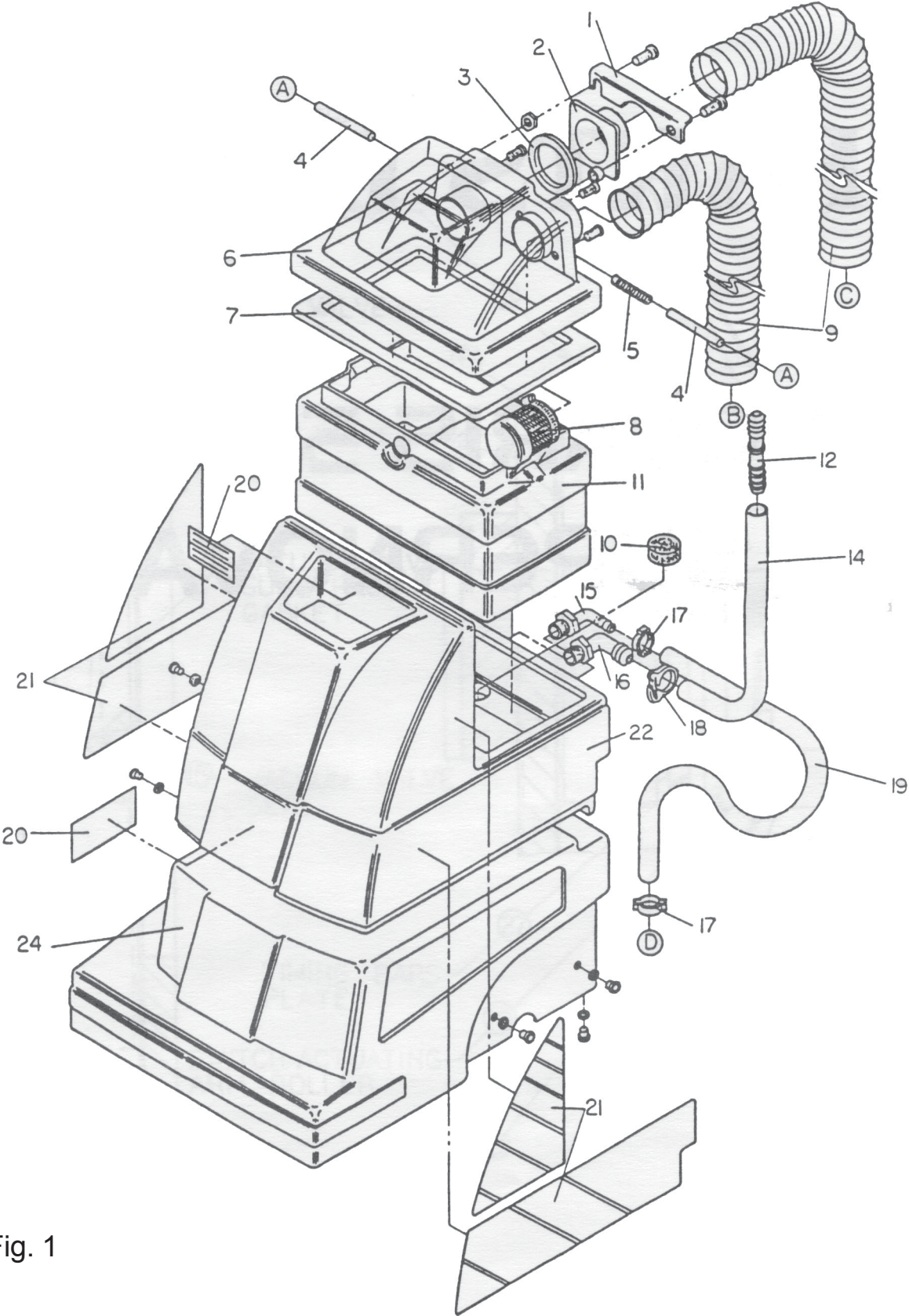
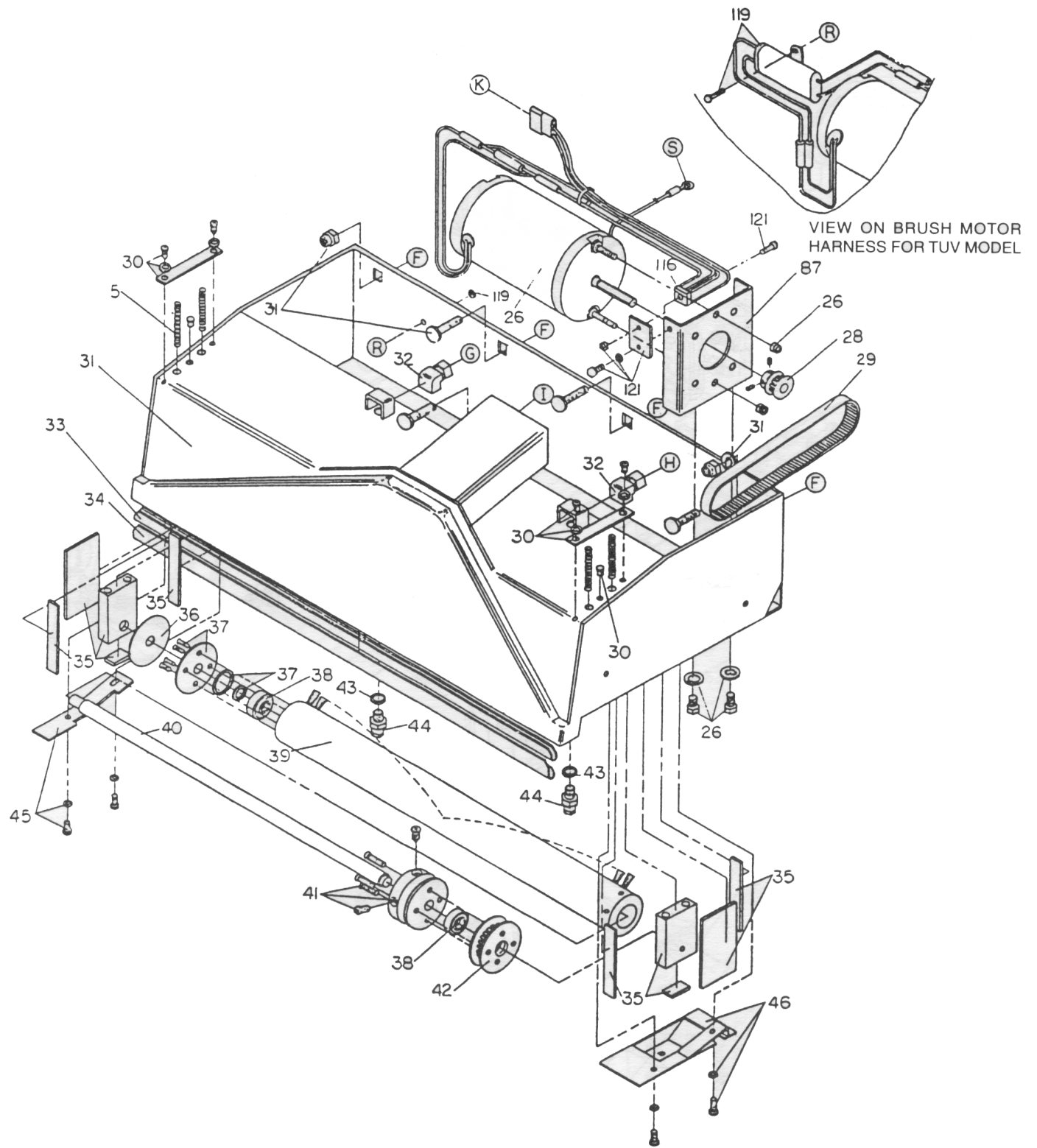

Fig. 1



Fastracts SC7

Fig. 2

Fastracts SC7

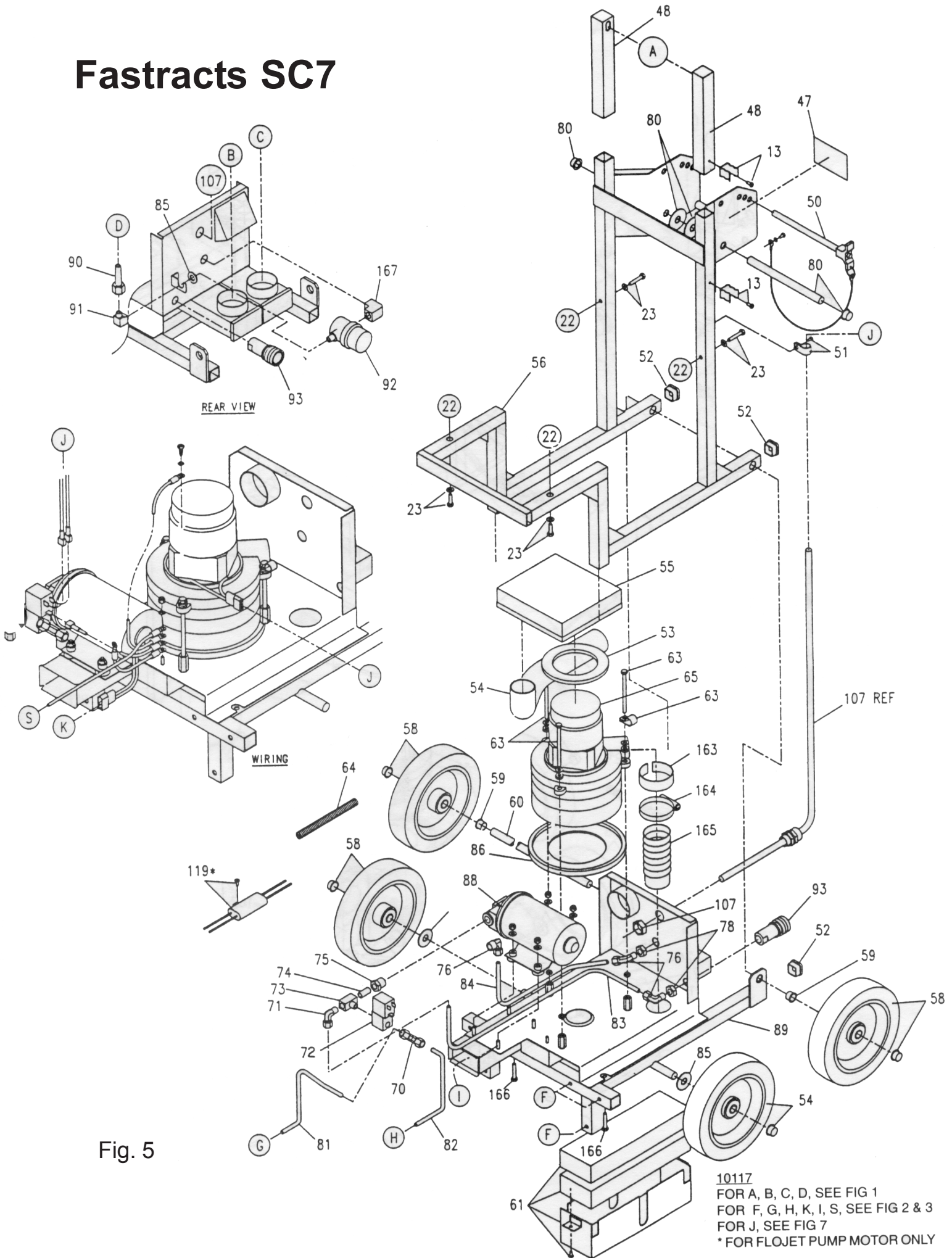
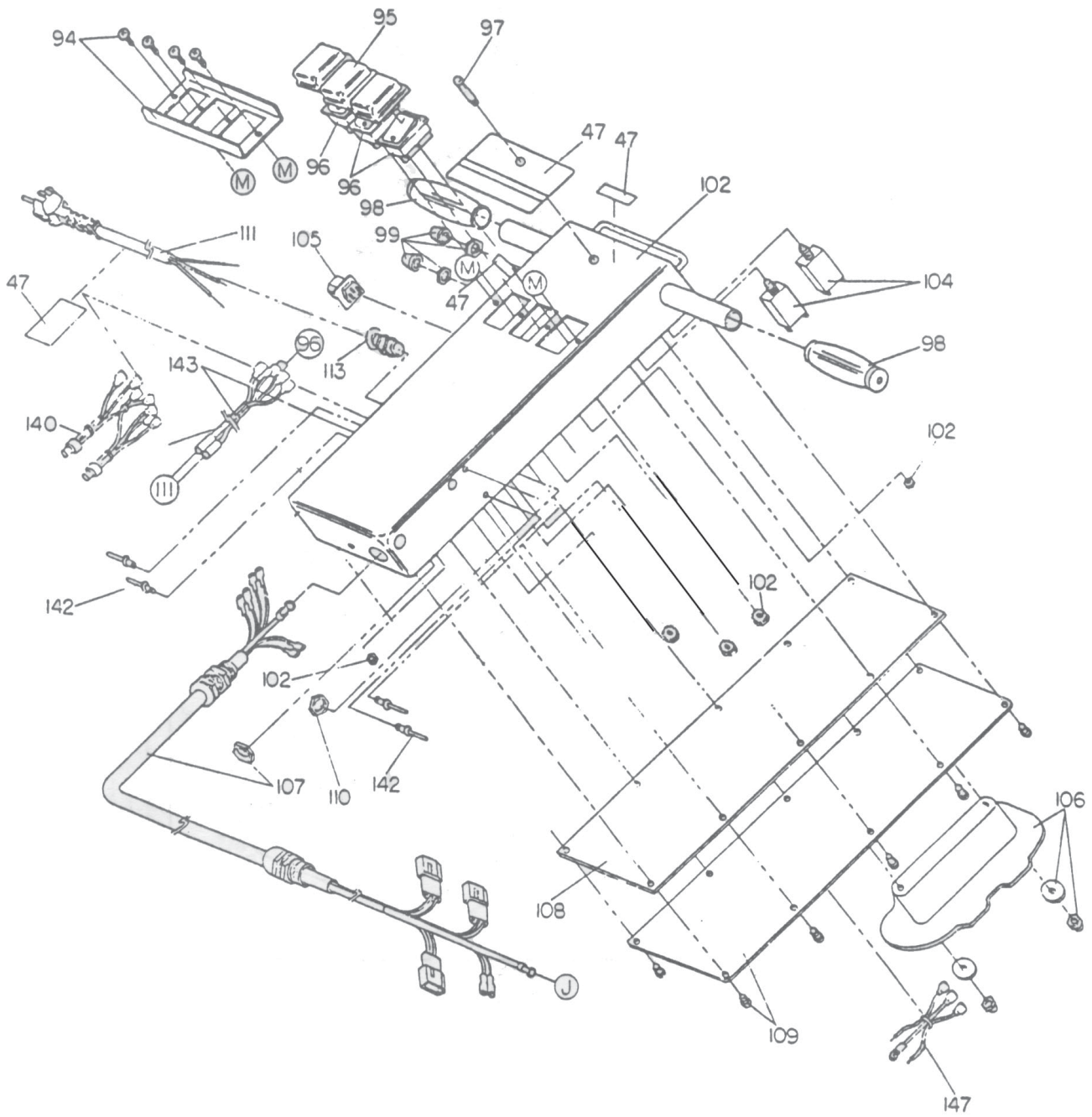

Fig. 5

10117
 FOR A, B, C, D, SEE FIG 1
 FOR F, G, H, K, I, S, SEE FIG 2 & 3
 FOR J, SEE FIG 7
 * FOR FLOJET PUMP MOTOR ONLY



Fastracts SC7

Fig. 7

**PARTS LIST
FASTRACTS SC7**

Item	Description	Part No.	Qty.	Fig.
1	CLIP, ADAPTER RETAINER	D02391	1	1
2	HOSE, ADAPTOR	D02359	1	1
3	SEAL, VACUUM INTAKE	E02431	1	1
4	SHAFT, LID PIVOT	D02373-1	2	1
5	SPRING, DOME PIVOT	D02372	1	1
	SPRING, SLIDE BLOCK	D02372	4	2 & 3
6	VACUUM LID ASSEMBLY	80491-1A	1	1
7	GASKET, VACUUM LID	E03431	1	1
8	FILTER SCREEN ASSEMBLY, VACUUM LID	82407A	1	1
9	HOSE, VACUUM, 2" ID	J00618	2	1
10	PLUG, SOLUTION TANK	L00767	1	1
11	RECOVERY PAIL	F02465-10	1	1
12	DRAIN NOZZLE, 1/2 BARB x 1/2 BARB	A00165	1	1
13	CLIP ASSEMBLY, DRAIN HOSE	80263-3A	2	5 & 6
14	HOSE, DRAIN, 5/8 OD x 1/8 WALL	J00598	1	1
15	90 ELBOW, 1/2 MP x 3/8 BARB	A00138	1	1
16	90 ELBOW, 1/2 MP x 5/8 BARB	A00099	1	1
17	CLAMP, HOSE, 5/8	J00637	2	1
18	CLAMP, HOSE, 7/8	J00652	1	1
19	HOSE, SOLUTION, 3/8 ID	J00613	1	1
20	LABEL KIT	82570-IA	1	1
21	DECAL KIT	H02561	1	1
	DECAL KIT	H02552	1	1
22	SOLUTION TANK ASSEMBLY	F02463-14	1	1
23	SOLUTION TANK MOUNTING KIT	82310A	1	5 & 6
24	HOUSING, MOTOR, 17"	F02470-7	1	1
26	BRUSH DRIVE MOTOR ASSEMBLY (115V)	82538A	1	2 & 3
27	WIRE ASSEMBLY, GROUND (BRUSH MOTOR)	00185-6A	1	2 & 3
	WIRE ASSEMBLY, GROUND (VACUUM MOTOR)	00185-6A	1	5
28	PULLEY, BRUSH DRIVE MOTOR	D00398-1	1	2 & 3
29	BELT, TIMING	L00779-1	1	2 & 3
30	COVER PLATE ASSEMBLY, SPRING	82378A	1	2 & 3

PARTS LIST
FASTRACTS SC7 and SC12

Item	Description	Part No.	Qty	Fig.
31	BRUSH CHAMBER ASSEMBLY (17")	82406A	1	2&3
32	90 ELBOW, 1/8 FP x 1 /4 C (17")	A00144	2	2&3
33	GLIDE, BACK (17")	D02389-1	1(2)	2&3
34	GLIDE, FRONT (17")	D02389	1(2)	2&3
35	SLIDE BLOCK ASSEMBLY	80500A	2	2
36	WASHER, SLIDE BLOCK, 1/16 THK, 25/64 ID, 2" OD	F00504	1	2
37	STRING GUARD ASSEMBLY	82235A	1	2
38	BEARING, BRUSH	G00536	2	2
39	BRUSH, ROTARY (17")	F02476	1	2
40	SHAFT, BRUSH (17")	D02387	1	2
41	SLINGER ASSEMBLY, ROTARY BRUSH	82376A	1	2
42	PULLEY, ROTARY BRUSH	D00398-2	1	2
43	WASHER, 3/32 THK, 7/16 ID, 5/8 OD (17")	C02298	2(4)	2&3
44	SPRAY TIP (17")	A00091	2(4)	2&3
45	COVER PLATE ASSEMBLY, OPEN END	82368A	1	2&3
46	COVER PLATE ASSEMBLY, PULLEY END	82367A	1	2&3
48	PIVOT EXTENSION, LID FRAME	D02344	2	5&6
50	PIN ASSEMBLY, RETAINING	82383A	1	5&6
51	CLAMP ASSEMBLY, CORD	80187A	1	5&6
52	CAP, END	K00712-4	4	5&6
53	GASKET, COOLING AIR DUCT	E02450	1	5&6
54	HOSE, EXHAUST, 2"	J00654	1	5&6
55	DUCT, COOLING AIR	D02394	1	5&6
56	FRAME, UPPER	D010074	1	5&6
58	WHEEL ASSEMBLY	82535A	1	5&6
59	BUSHING	K00674	2	5&6
60	AXLE, WHEEL	D02398	1	5&6

PARTS LIST
FASTRACTS SC7 and SC12

Item	Description	Part No.	Qty.	Fig
63	VACUUM MOTOR MOUNTING ASSEMBLY (3 STAGE)	80317-3A	1	5&6
64	LOOM, CORRUGATED	F00463	1	5&6
65	VACUUM MOTOR, 2 STAGE, 115V	02517-2A	1	5&6
70	BUSHING, 1/8 MP x 1/4 C	A00125	1	5
71	90 ELBOW, 1/8 MP x 1/4 C	A00132	1	5&6
72	SOLENOID, 1 /8 NPT (220V)	G02537	1	5&6
73	BRANCH TEE, MALE 1/8 NPT	A00152	1	5&6
74	NIPPLE, SHORT, 1/8 NPT	A00055	1	5&6
75	BUSHING, REDUCER, 1/4 NPT (100 PSI)	A00168-18	1	5&6
77	90 ELBOW, 1/4 MP x 1/4 C (100 PSI)	A00140	1	5&6
78	NUT, HEX	A00124	2	5&6
80	SHAFT ASSEMBLY, HANDLE	804186A	1	5&6
81	TUBE, SOLENOID TO R SPRAY TIP (17")	A00085-9	1	5&6
83	TUBE, PUMP TO ACCESSORY LINE	A00085-10	1	5&6
84	TUBE, PUMP TO SOLUTION INTAKE LINE	A00085-11	1	5&6
85	SPACER, 3/16 THK, 1/2 ID, 1" OD	C00240	3	5&6
86	GASKET, VACUUM MOTOR	E02448	1	5&6
87	BRACKET, BRUSH DRIVE MOTOR	D02370	1	2&3
88	PUMP, 115V, 50PSI	10763-1A	1	5&6
89	LOWER FRAME ASSEMBLY	82359A	1	5&6
90	ADAPTER, 3/8 BARB x 1/4 FP	A00061	1	5&6
91	90 ELBOW, 1/4 FP x 1/4 MP	A00052	1	5&6
92	FILTER STRAINER, IN-LINE	K00709	1	5&6
	SCREEN, IN-LINE STRAINER	K00709-1	1	5&6
	CAP, IN-LINE STRAINER	K00709-2	1	5&6
93	QUICK DISCONNECT, 1/4 FP x 1/4 FP	A00102	1	5&6
94	SWITCH GUARD ASSEMBLY	82414A	1	7
95	COVER, ROCKER SWITCH	B00214-2	3	7
96	SWITCH, LIGHTED, ROCKER	B02211-1	3	7

PARTS LIST
FASTRACTS SC7 and SC12

Item	Description	Part No.	Qty.	Fig.
97	LIGHT, INDICATOR, GREEN LENS	B02196	1	7
98	GRIP, HANDLE, BLACK	K00715B-1	2	7
99	BOOT, FLEX, CIRCUIT BREAKER (TUV)	B02193	2	7
100	SPRING, BRACKET, VACUUM VALVE, ASSEMBLY	83349A	1	4
101	SPRING, VACUUM VALVE SLIDE RETURN	D03371	2	4
102	HANDLE, ADJUSTABLE	D02403	1	7
104	CIRCUIT BREAKER, 3 A	B02192	1	7
105	OUTLET ASSY, ACCESSORY	80188A	1	7
106	CORD WRAP ASSEMBLY	82408A	1	7
107	CORD ASSEMBLY, HANDLE TO LOWER FRAME	00185-28A	1	5,6,7
108	GASKET, HANDLE	E03432	1	7
109	COVER PLATE ASSEMBLY	82409A	1	7
110	LOCK NUT (115VAC)	B02214	1	7
111	CORD, POWER (115VAC)	B00221	1	7
113	STRAIN RELIEF, POWER CORD (115VAC)	B02215	1	7
163	GASKET HORN	E02441	1	5 & 6
164	CLAMP, HOSE, SCREW TYPE	J00639	1	5 & 6
165	HOSE ASSEMBLY, VACUUM EXHAUST	800618A	1	5&6
166	SCREW, MACHINE, HEX HEAD, 1/4-20 x 1 1/4	C02310	2	5 & 6
167	90 ELBOW, 1/4 FP x 1/4 FP	A00154	1	5 & 6

Fastracts SC7

115V 50/60 HZ WIRING DIAGRAM

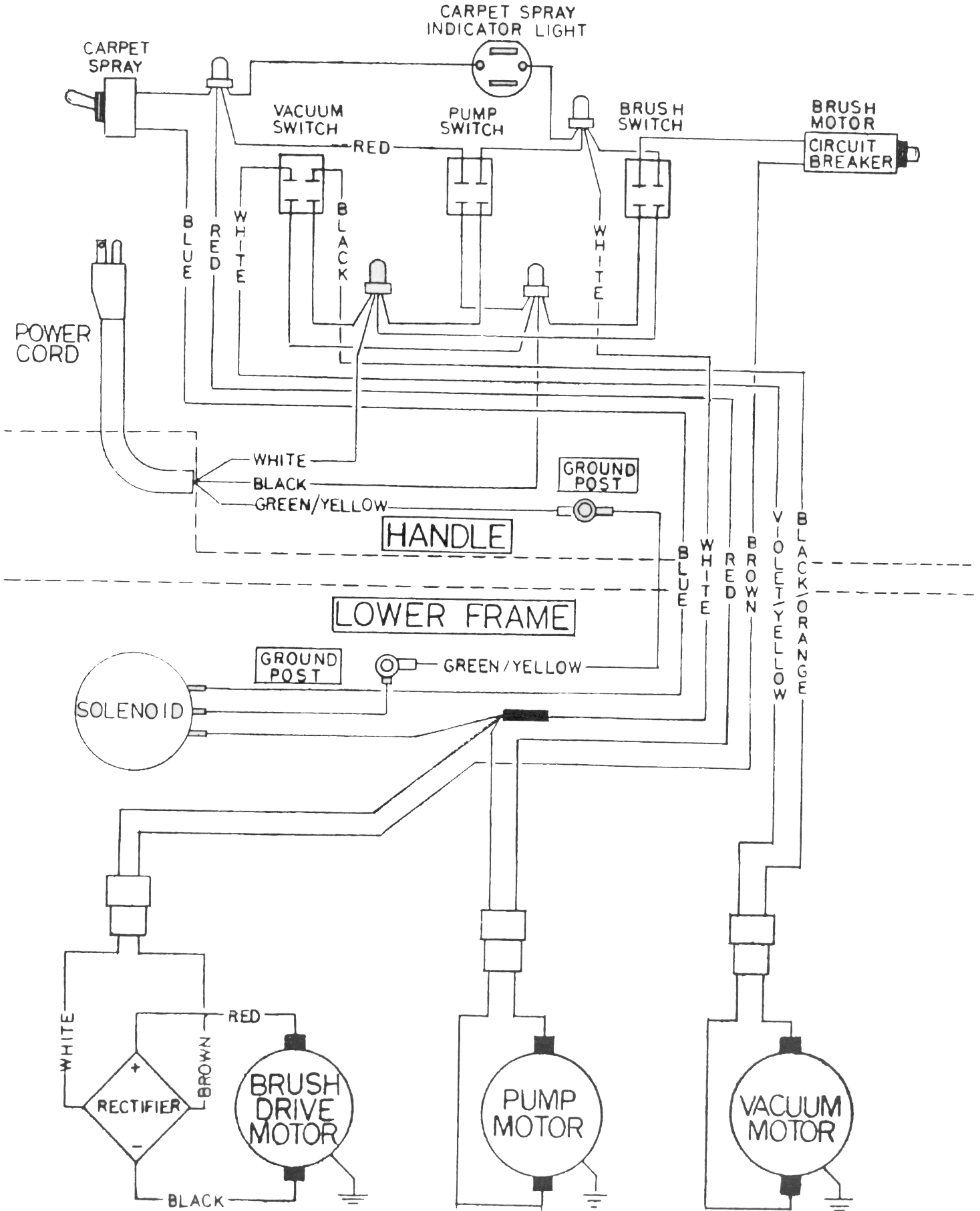



IPC Eagle

Warranty Policy

Limited Warranty

Eagle Power Products (EPP) warrants new cleaning equipment against defects in material and workmanship under normal use and service to the original purchaser as detailed below.

10 Years

Subject to the conditions stated below, EPP warrants polyethylene tanks and housings to be free from defects in materials and workmanship for a period of ten years.

3 Years

Subject to the conditions stated below, EPP warrants all automatic scrubber components to be free from defects in materials and workmanship for a 3-year period. Parts replaced or repaired are warranted for the remainder of the original warranty period.

1 Year

Subject to the conditions stated below, EPP warrants all other cleaning equipment components to be free from defects in materials and workmanship for a 1-year period. Parts replaced or repaired are warranted for the remainder of the original warranty period. Batteries are prorated for one year.

EPP will furnish and charge for replacement parts, including transportation, to the original owner through an EPP authorized service center. If the part is returned within 30 days and is found defective, the owner will be credited for the cost of the replacement part including shipping and handling.

Labor charges are covered for one year from the date of purchase if provided by an authorized EPP service center. Travel is covered for 90 days for battery operated equipment only.

Wear items exempt from warranty include belts, carbon brushes, power cords, wheels, pad drivers, clutch plates, brushes, pads, handle grips, filters, screens, throttle cables, and squeegees.

This warranty shall not apply to failures caused by misuse or abuse, improper maintenance as stated in the operation manuals, use of unauthorized repair parts, repairs by other than an EPP authorized service center, and damage in transit.

EPP disclaims and denies any liability for any direct, indirect, special incidental or consequential damage which may be suffered as a result of sale, delivery, servicing, use, loss of any product, downtime, labor, freight, or other charges not expressly included herein.

Date Purchased: _____

Model Number: _____

Serial Number: _____

Please be sure to record this information. This information will be necessary for future warranty claims.



IPC Eagle

3650 Dodd Rd, Eagan MN 551213
800-486-2775, 651-686-5399
www.ipceage.com

IPC Eagle Products Sales and Service Provided by: