



Electronic Service Manuals

This electronic document is provided as a service to our customers. We do not create the contents of the information contained in this document. Should you have detailed questions pertaining to the information contained in this document, you may contact Michco, or the manufacturer which provided the original information in this electronic deliverable. Michco's only part in this electronic deliverable was the electronic assembly process. By providing this manual on line we are not guaranteeing parts availability.

You may contact Michco through the following methods:

Phone (517) 484-9312 or (800) 331-3339

2011 N. High St. -- Lansing, Michigan -- 48906

Fax: (517) 484-9836

Email: CustServe@Michco.com

Web site: www.Michco.Com

Parts Web site: www.FloorMachineParts.Com

Order Parts on Line at:

www.FloorMachineParts.Com

Directly to Parts & Service:

By Email: **Shop@Michco.com**

By Fax: (517) 702-2041

By Voice: Use numbers above.

Serving the Cleaning Industry Since 1922

Notice: All copyrighted material remains property of original owners, all trademarks are property of respective owners. Manuals are subject to Manufacturer's reproduction limitations. Originals or reproductions were provided by manufacturers through a request. We make no warranty as to the correctness of information provided in this document and you assume all risk. By placing these manuals on line we are not declaring our corporation to be an manufacturer authorized dealer or provider, please check our web site for authorized manufacturers we represent.

JOB Extractor

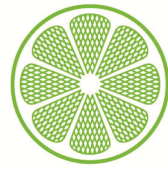

IPC Eagle

Operations and Parts Manual



IMPORTANT SAFETY INSTRUCTIONS

When using an electrical appliance, basic precaution must always be followed, including the following:

READ ALL INSTRUCTIONS BEFORE USING THIS MACHINE.

This machine is for commercial use.

WARNING



DANGER: Failure to read and observe all DANGER statements could result in severe bodily injury or death. Read and observe all DANGER statements found in your Owner's Manual and on your machine.



WARNING: Failure to read and observe all WARNING statements could result in injury to you or to other personnel; property damage could occur as well. Read and observe all WARNING statements found in your Owner's Manual and on your machine.



CAUTION: Failure to read and observe all CAUTION statements could result in damage to the machine or to other property. Read and observe all CAUTION statements found in your Owner's Manual and your machine.



DANGER: Failure to read the Owner's Manual prior to operating or attempting any service or maintenance procedure to your machine could result in injury to you or to other personnel; damage to the machine or to other property could result as well. You must have training in the operation of this machine before using it. If you or your operator(s) cannot read English, have this manual explained fully before attempting to operate this machine.



DANGER: Operating a machine that is not completely or fully assembled could result in injury or property damage. Do not operate this machine until it is completely assembled. Inspect the machine carefully before operation. Use only as described in this manual. Use only the manufacturer's recommended attachments.



DANGER: Machines can cause an explosion when operated near flammable materials and vapors. Do not use this machine with or near fuels, grain dust, solvents, thinners, or other flammable materials.



DANGER: Do not pick up flammable fluids, dust or vapors.



DANGER: Do not vacuum anything that is burning or smoking, such as cigarettes, matches, or hot ashes.



DANGER: This machine is not suitable for picking up health endangering dust.



DANGER: Using a machine with a damaged power cord could result in an electrocution. Do not use the machine if the power cord is damaged. Do not use the electrical cord to move the machine. Keep cord away from heated surfaces. Do not unplug by pulling on the cord; grasp the plug, not the cord. Turn off all controls before unplugging. Do not close a door on cord or pull around sharp edges or corners.



DANGER: Electrocution could occur if maintenance and repairs are performed on a unit that is not properly disconnected from the power source. Disconnect the power supply before attempting any maintenance or service.



Warning: Operating a machine without observing all labels, decals, etc., could result in injury or damage. Read all machine labels before attempting to operate the machine. Make sure all of the labels are attached or fastened to the machine. Get replacement labels and decals from the manufacturer's distributor.



Warning: Electrical components can "short-out" if exposed to water or moisture. Keep the electrical components of the machine dry. Always store the machine in a dry area.



Warning: Use of this machine to move other objects or to climb on could result in injury to the operator or damage to the machine. Do not use this machine as a step or furniture. Do not allow to be used as a toy. Close attention is necessary when used by or near children.



Warning: Moving parts of this machine can cause injury and/or damage. Keep hands, feet, loose clothing, hair, fingers, and all parts of the body away from openings and moving parts.



Warning: Electrocutation could occur if you handle the plug or appliance with wet hands. Do not handle plug or appliance with wet hands.



Warning: Do not use without dust bag and or filters in place.



Warning: Rotating fan blades inside the cover. Before opening cover, switch off machine. Wait until the fan/brush stops completely or dust and debris may be ejected.



Warning: If the machine is not working properly, has been dropped, damaged, left outdoors, or dropped into water, return it to an Authorized service center.



Warning: Damage could occur to machine if openings are blocked. Do not put any object into openings. Do not use any opening blocked: keep free of dust, lint, hair, and anything that may reduce air flow.



Warning: Injury could occur to the operator or the machine if used without the dust bag and/or filters in place. Do not use the machine without the dust bag and/or filters in place.



Warning: Injury to the operator and/or damage to the machine could occur when cleaning on stairs, unless caution is used. Use extreme caution when cleaning on stairs.



Warning: To reduce the risk of electrical shock, always use a 3-wire electrical system connected to the electrical ground. Whenever possible connect the machine to an outlet protected by a ground fault interrupter (GFCI). See "Grounding Instructions."

SAVE THESE INSTRUCTIONS

120 Volt Machine Instructions For Connection To The Power Supply And The Electrical Ground

This machine must be connected to the electrical ground to protect the operator from electrical shock. The machine has an approved power cord with three conductors and a plug with three terminals. Connect the plug to a receptacle that has three holes and is connected to the electrical ground. The green (or green and yellow) conductor in the cord is the ground wire. Never connect this wire to any terminal other than the ground terminal.

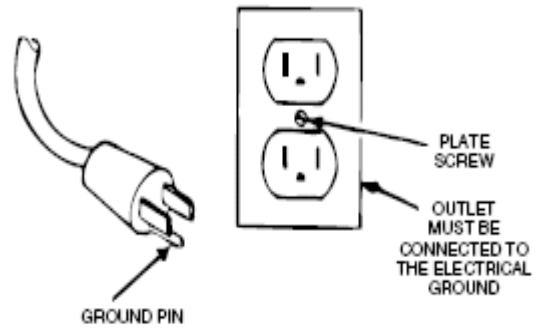

This machine uses a 120 volt AC 60 cycle electrical circuit. Make sure you have the correct frequency and voltage before connecting the power cord to an outlet. The machine has a plug as shown in Figure 1. If a receptacle connected to the electrical ground as shown in Figure 1 is not available, have one installed by an electrical contractor. **Do not use an adapter.**

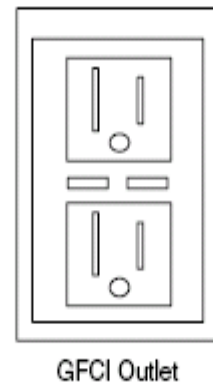

Warning: To reduce the risk of electrical shock, protect the machine from rain. Keep the machine in a dry area.



Warning: To reduce the risk of electrical shock, always use a 3-wire electrical system connected to the electrical ground. Whenever possible connect the machine to an outlet protected by a ground fault interrupter (GFCI).



Warning: Do not cut, remove or break the ground pin. If the outlet does not fit the plug, consult your electrical contractor.



Warning: Have worn, cut or damaged cords and plugs replaced by an authorized service person.



Warning: If it becomes necessary to use an extension cord to reach an electrical outlet, you must use one that is at least one size larger in wire size. Such as a power cord that is marked 12/3 would need to use an extension cord that is marked 10/3. Do not use an extension cord that is undersized.

IMPORTANT INSTRUCTIONS

- Before use, the equipment must be correctly assembled with all of its components
- Check that the electrical outlet is correct for use with the plug on the machine
- Before connecting, check that the specified motor voltage corresponds to the main voltage available
- Never use the equipment near flammable, explosive or toxic substances: sparks from the motor could cause dangerous reactions.
- Always unplug the machine from the electrical outlet when leaving machine unattended or before attempting any repair.
- Service and repair should be done by qualified personnel only. Use only original manufacturer's replacement parts.

Daily Maintenance

Caution: Some detergents produce foam which will damage the vacuum motor. The vac shut-off may not be sensitive to all foams. Be sure to check that the tank is not filling with foam. Use a defoaming agent to avoid pulling foam through the vacuum motor. Should vac motor become wet, remove source of overflow and immediately run vac motor open to dry.

After Use

1. After each use, rinse tank with fresh water. Periodically inspect the recovery tank and decontaminate if necessary, using a hospital grade virucide or a 1:10 bleach to water solution. Waste water should be disposed of properly.
2. Remove head assembly and allow tank to dry.
3. Remove filters for cleaning and allow to dry.
4. Inspect hoses for wear. Frayed or cracked hoses should be replaced to avoid vacuum loss.
5. Store the cord on the hook.
6. Inspect power cord for wear. This cable will lay on wet surfaces. To prevent electrical shock replace cords with frayed or cracked insulation immediately.
7. This appliance is provided with an automatically reset thermal limiter to avoid damage to motor. If thermal limiter operates do one or more of the following:
 - Check hose and tank inlet for any obstructions
 - Wait a few minutes for the thermal limiter to re-close the circuit

Injection - Extraction Washing



1. Pour cleaning solution and water into the solution tank.



2. Insert the solution tank into the recovery tank.



3. Attach the vacuum head onto the tank by guiding the solution hose Y into the solution tank, Clamp the vacuum head to the tank.



4. Connect vacuum hose to the tank.

5. Connect the solution hose to the power head by simply inserting the male hose end fitting into female fitting until it locks. To remove, press red button to unlock and pull apart.



6. Connect trigger gun to the solution hose.



7. Attach appropriate accessory:
- Wand and carpet tool for carpets. See Extraction Wand Assembly, page 4.
- Wand, carpet tool and squeegee brush shoe for hard floors. See Extraction Wand Assembly, page 4.
- Upholstery tool for upholstery



8. Press the green switch to activate the solution pump. Press the red switch to activate the vacuum motor.

9. To clean, press trigger to inject cleaning solution, press tool down firmly and pull towards you.



EXTRACTION WAND ASSEMBLY

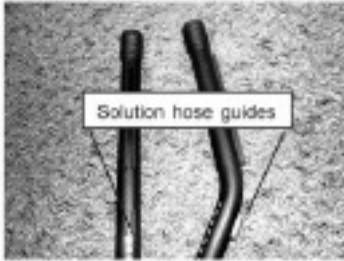

1. Locate the lower bent wand piece and the straight wand piece. The solution hose guides molded on one side easily identify these pieces.



2. Firmly press the lower bent wand piece into the straight wand piece. Make sure the solution hose guides are aligned with each other.



3. Firmly press the lower bent wand piece into the carpet tool.



4. Clip injection nozzle to carpet tool.



5. Press the solution hose into the solution hose guide, starting at nozzle.

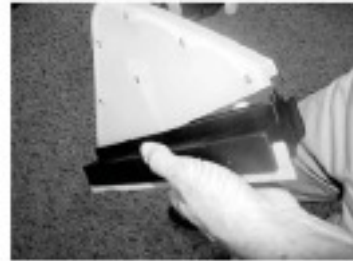

6. For hard floors only, snap squeegee brush shoe onto carpet tool.



7. Firmly insert upper bent wand and trigger into the straight wand.



8. Connect solution hose to the trigger by inserting until it locks into place. To remove, press the red button and pull the connector out of the trigger.

Periodic Maintenance

(Every six to twelve months)

1. Check filter for wear, replace dirt saturated filters that do not respond to normal cleaning.
2. Inspect gasket seals and replace those which have begun to leak.
3. Examine carbon motor brushes and commutator.

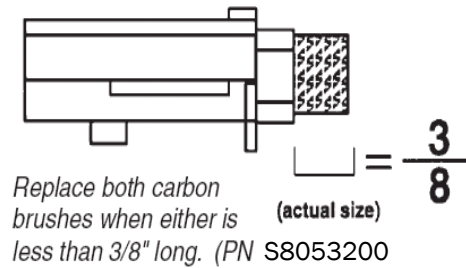

Servicing The Filter

The filter is accessed by lifting the head assembly off the tank.

The Polyester filter assembly is easily removed by simply lifting the filter basket out of the tank.

The cartridge filters they are removed very easily. First remove the filter retainer by turning the black knob 90 degrees counter-clockwise. The cartridge filter will then slide off of the support assembly.

Note:

- Be sure to frequently clean the filters.
- Allow filters to thoroughly air dry after washing them before returning them to the machine.
- Worn filters can affect vacuum performance. Replace the filters when they become worn out and normal cleaning will not restore vacuum performance.

Servicing The Vac Motor

Motor Replacement

1. Disconnect power cord from power source.
2. To access the vac motor, remove the screws that attach the main cover to the head assembly and set the cover to one side.
3. Disconnect the motor's 2 red lead wires from the main wiring bridge.
4. Disconnect green/yellow wire by removing the screw from the motor core.
5. Remove the four motor mounting screws.
6. Remove motor plate and set aside.
7. Take out the motor and remove the upper and lower gaskets.
8. Inspect gaskets. If they show signs of wear replace the.
9. Install gaskets onto new motor ensuring that they are properly seated.
10. Install the new motor. Make sure foam mufflers are positioned properly.
11. Attach motor plate to motor.
12. Connect green/yellow wire to motor core.
13. Connect motor's 2 red lead wires to main wiring bridge.
14. Re-assemble vac cover.
15. Test for proper operation.

Servicing The Vac Motor

Carbon Brush Replacement

(Replacement Carbon Brushes: Part# S8053200)

1. Disconnect power cord from power source.
2. To access the vac motor, remove the screws that attach the main cover to the head assembly and set the cover to one side.
3. Remove the screws that attach the inner cover to the head assembly and set aside.
4. Remove the carbon brush assembly by removing the 2 screws that attach it to the vac motor. See Figure 1
5. Slide off the carbon brush connector from the motor terminal. See Figure 2
6. Inspect armature commuator. If it is extremely pitted, grooved or not concentric then the motor will need to be replaced or sent to a qualified service center.
7. Reverse steps 6 through 4 to install new carbon brush and housing.
8. Repeat steps 4 through 7 for the other carbon brush.
9. Reverse steps 3 and 2 for re-assembly.
10. Test for proper operation.

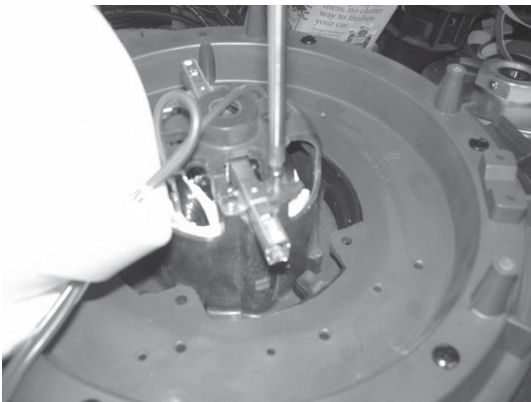

Figure 1

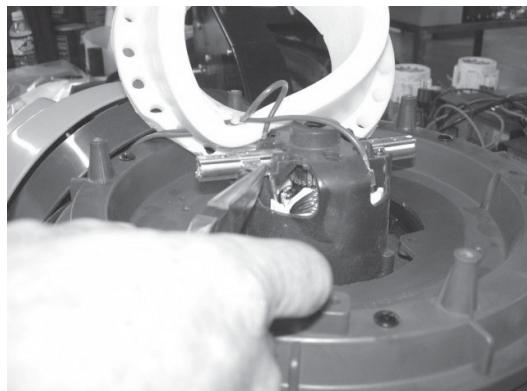
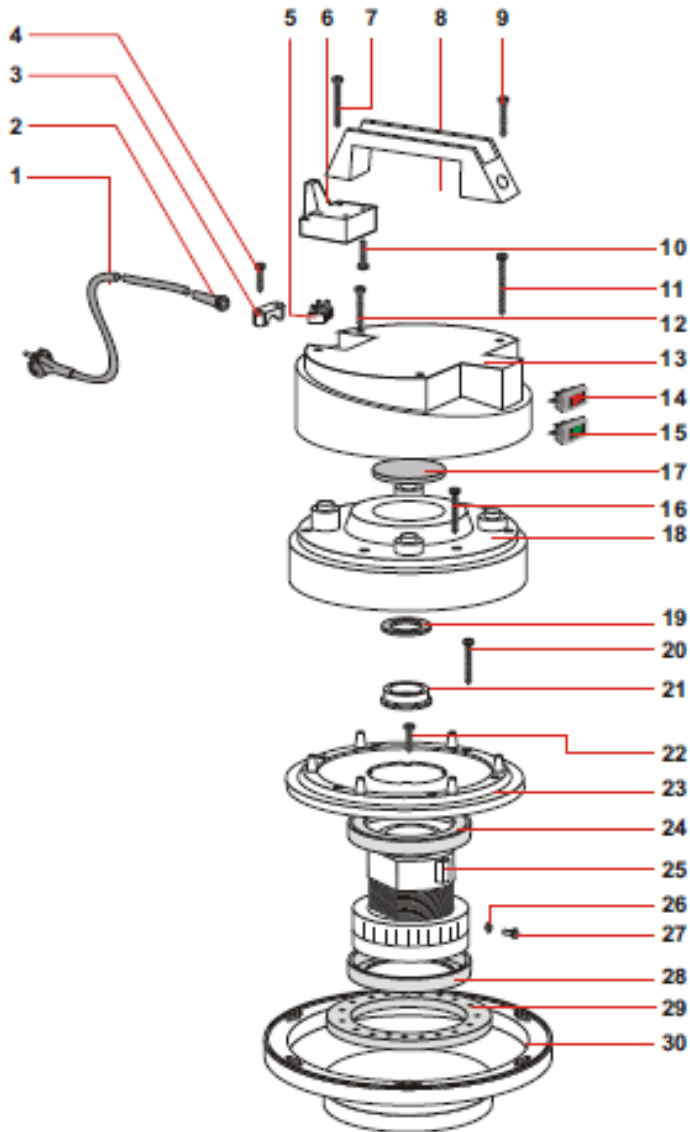

Figure 2

Job Extractor Vacuum Motor Head Assembly



No.	Part #	Description	Qty.
1	S81122	Power Cord	1
2	S80138	Strain Relief	1
3	S80139	Clamp, Cord	1
4	S81006	Screw 5x20	2
5	S86910	Terminal Block	1
6	S82928AUG6	Cord Hook	1
7	S82627	Screw 5x40	2
8	S82927G6	Handle	1
9	S81006	Screw 5x20	1
10	S81006	Screw 5x20	2
11	S81050	Screw 5x35	2
12	S81026	Screw 5x30	2
13	S82946AUG6	Cover, Job Extractor	1
14	S80484	Switch, Red	1
15	S80756	Switch, Green	1
16	S81050	Screw 5x35	4
17	S83937	Filter	1
18	S82633AUVEI	Cover, Intermediate	1
19	S83969	Gasket	1
20	S82627	Screw 5 x 40	6
21	S80310	Ring	1
22	S81006	Screw 5x20	4
23	S82634AUG6	Motor Retainer	1
24	S83901	Gasket	1
25	S81120S	Motor 1000watt 120V	1
26	S81024	Lock washer	1
27	S81064	Screw 4 x 8	1
28	S83901	Gasket	1
29	S83866	Foam, Sound Deadening	1
30	S82636	Base with Gasket	1

Job Extractor Pump Motor Assembly

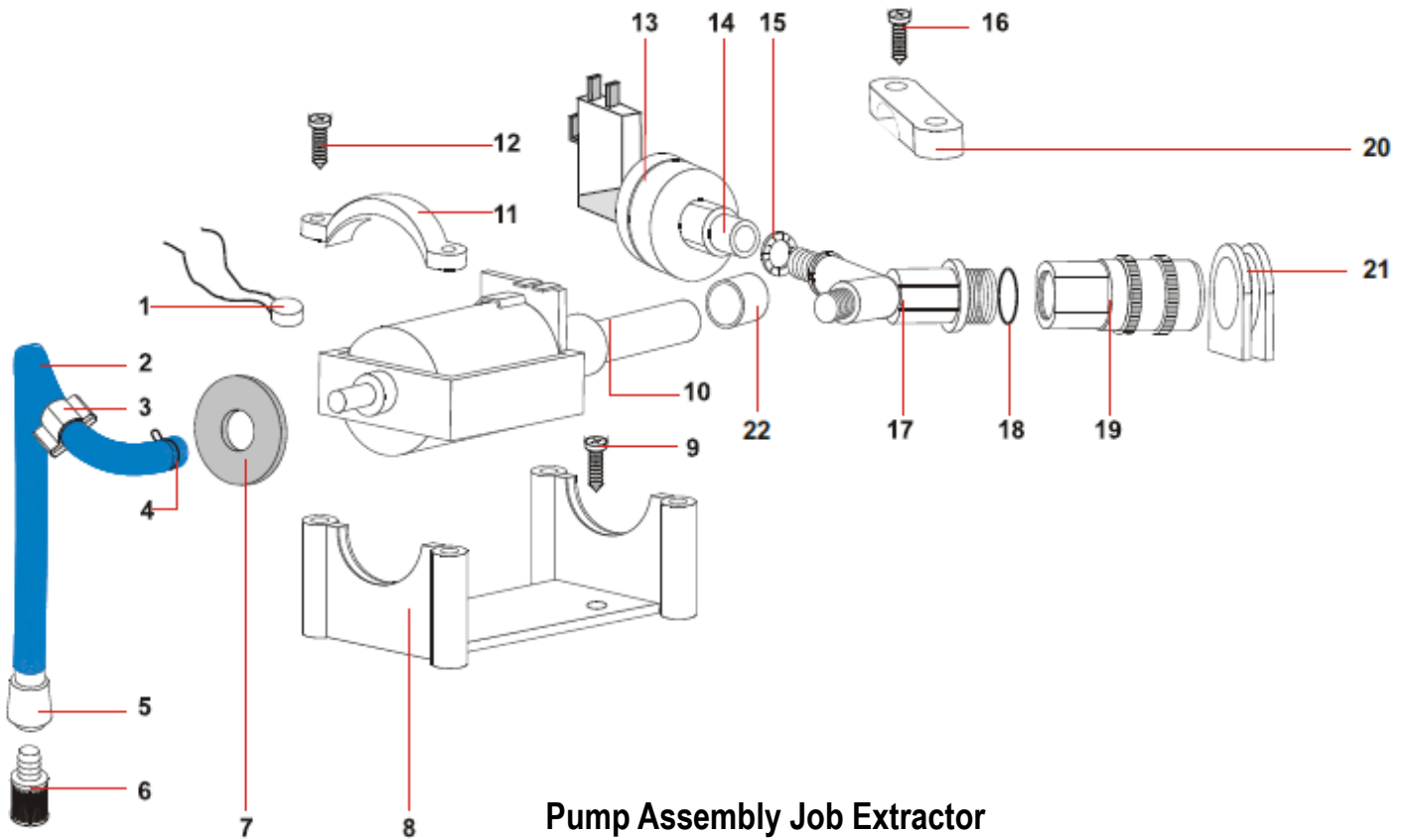

Pump Assembly Job Extractor

No.	Part #	Description	Qty.
1	S83037	Thermal Protector	1
2	S80723	Tube 8 x 5	1
3	S82660	Clamp	1
4	S82659	Clamp	1
5	S83036	Filter Housing	1
6	S82689	Filter	1
7	S82571	Washer 32 x 13 x 3	2
8	S82603	Pump U Support	1
9	S81005	Screw 5 x 14	2
10	S80799	Pump, 120V 60 Hz	1
11	S82602	Pump, U Bracket	2
12	S81979	Screw 5 x 25	4
13	S83919	Pressure Switch	1
14	S80689	Reducer 1/4" F - 1/8" F	1
15	S83722	Spacer Washer M10	1
16	S81979	Screw 5 x 25	2
17	S83096	"Y" Connector	1
18	S81610	O Ring 9	1
19	S83689/OTT	1/4" F Quick Disconnect	1
20	S82604	Clamp, Retainer	1
21	S86082	Grommet	1
22	S86118	Sleeve	1

Job Extractor Bucket Assembly

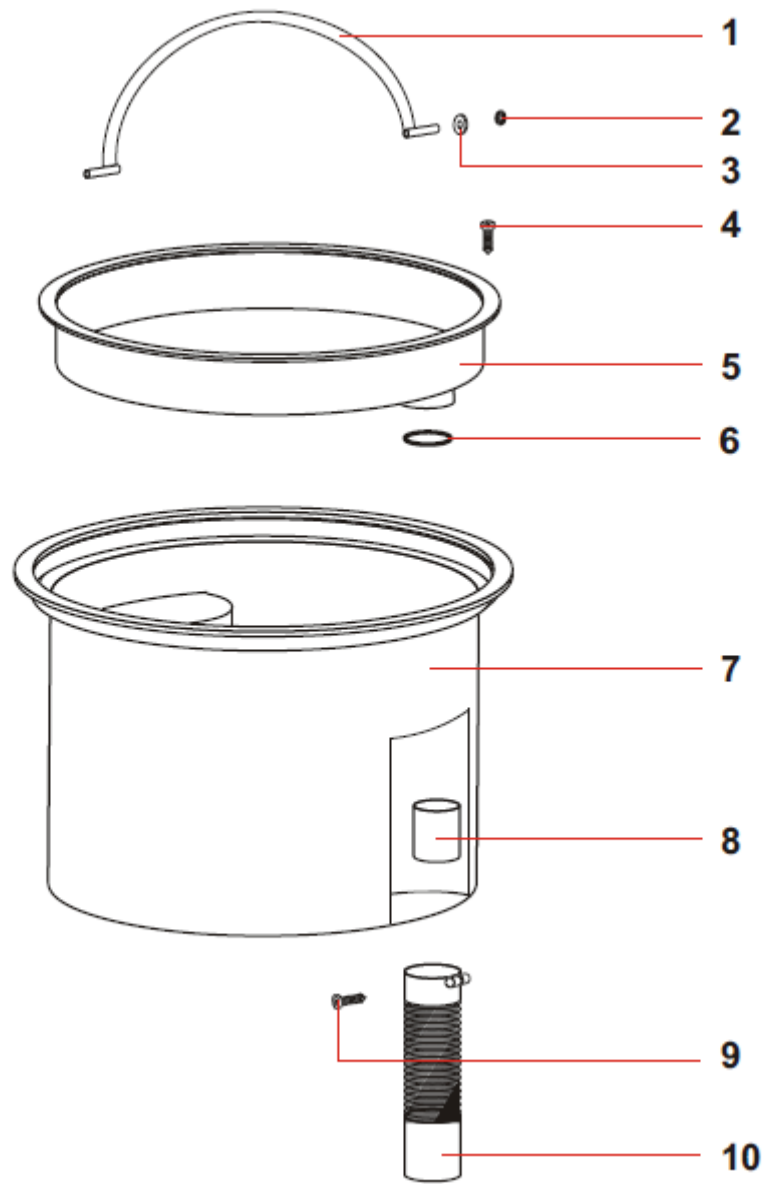

Bucket Assembly Job Extractor

No.	Part #	Description	Qty.
1	S82577	Handle	1
2	S82573	Washer Nylon D6	2
3	S81234	Washer 18 x 5 x 1.5	2
4	S82622	Screw 4.2 x 19	4
5	S82596	Cover, Bucket	1
6	S86601	O Ring	1
7	S82595	Bucket It. = 11	1
8	S82580-1	Float, Shut off	1
9	S86252	Screw 3.9 x 13	2
10	S82592-1	Filter, Bucket	1

Tank Assembly JOB Extractor

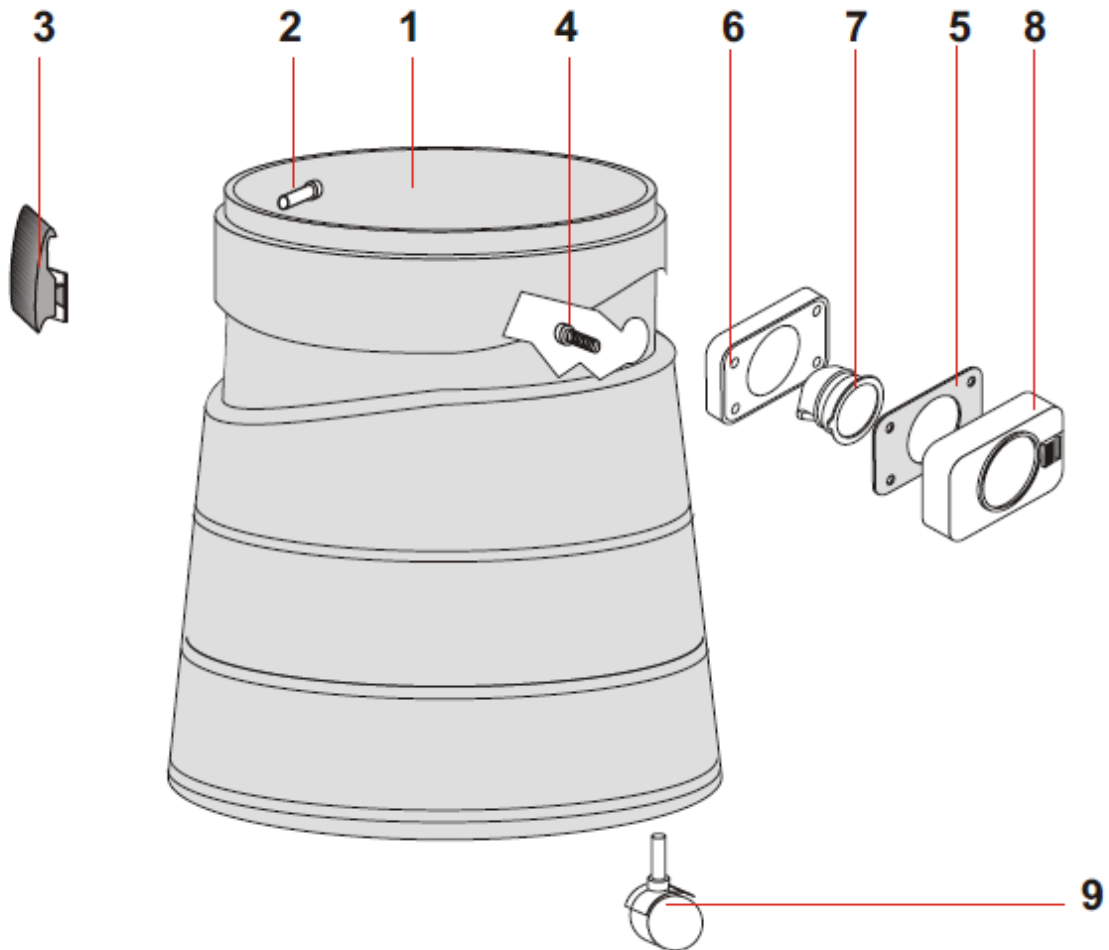

No.	Part#	Description	Qty.
	S82668	Complete Tank Assy.	1
1	S82599NE	Tank, Black	1
2	S81300	Rivet	4
3	S81847	Clamp	2
4	S81050	Screw 5x35	4
5	S82846	Gasket	1
6	S82586G6	Retainer	1
7	S82593	Deflector	1
8	S82652AG6VE	Inlet Cover	1
9	S80558	Caster	6

Wand/Trigger Assembly JOB Extractor

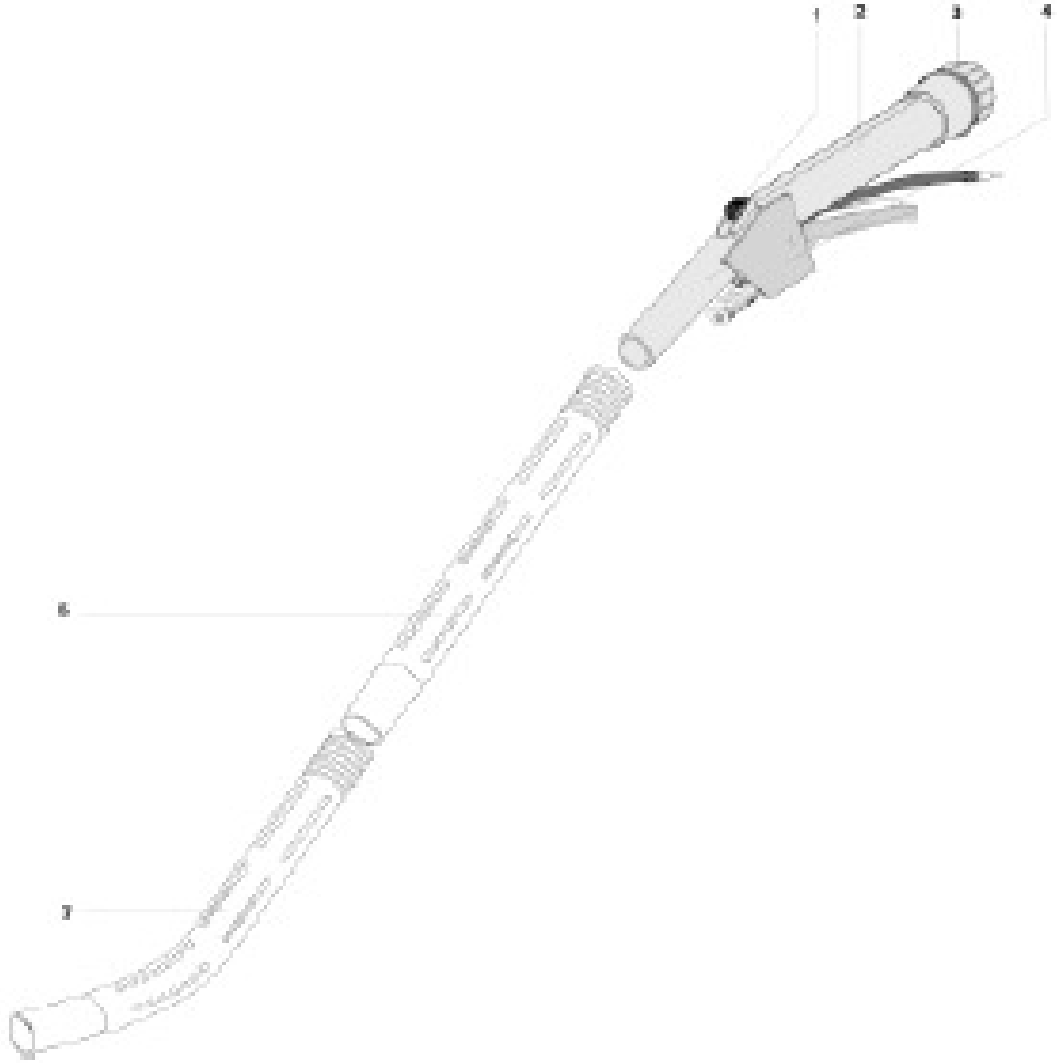

No.	Part#	Description	Qty.
1	S86167	Button	1
2	S86158A	Handle, Wand	1
3	S86188	Cuff	1
4	S86160OTT	Trigger Assembly	1
6	S86240IDRO	Wand, Straight	1
7	S86261IDRO	Wand, Curved	1

Wand/Head Assembly JOB Extractor

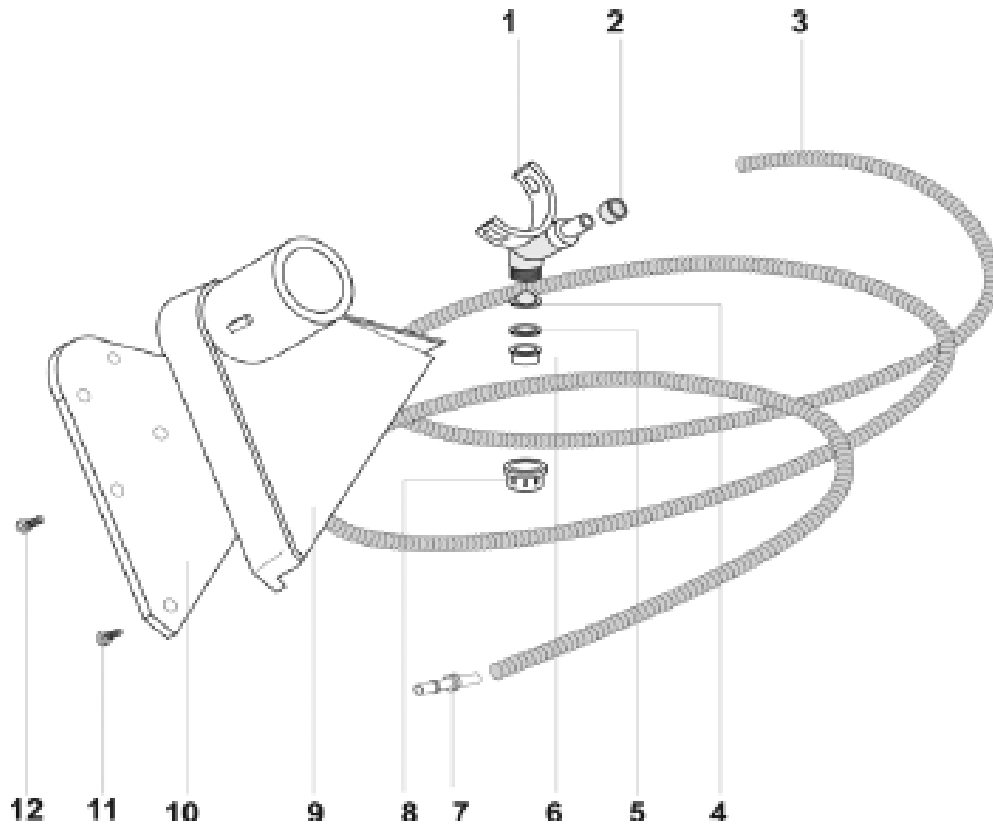

No.	Part#	Description	Qty.
1	S82732	Spray Tip Housing	1
2	S83171	Plastic Sleeve	2
3	S82747	Hose, Solution	1
4	S82711	Filter	1
5	S83060	Gasket	1
6	S83071	Spray Nozzle	1
7	S83664OTT	Quick Disconnect, Male	1
8	S82713	Cap	1
9	S82730	Extraction Head	1
10	S82731	Plate	1
11	S82727	Screw	2
12	S86252	Screw	5
1-8	S83572	Complete Spray Nozzle Assy.	
9-12	S82753	Complete Extraction Head Assy.	
	S82724	Complete Extraction Wand Assy.	

Hard Floor Tool JOB Extractor

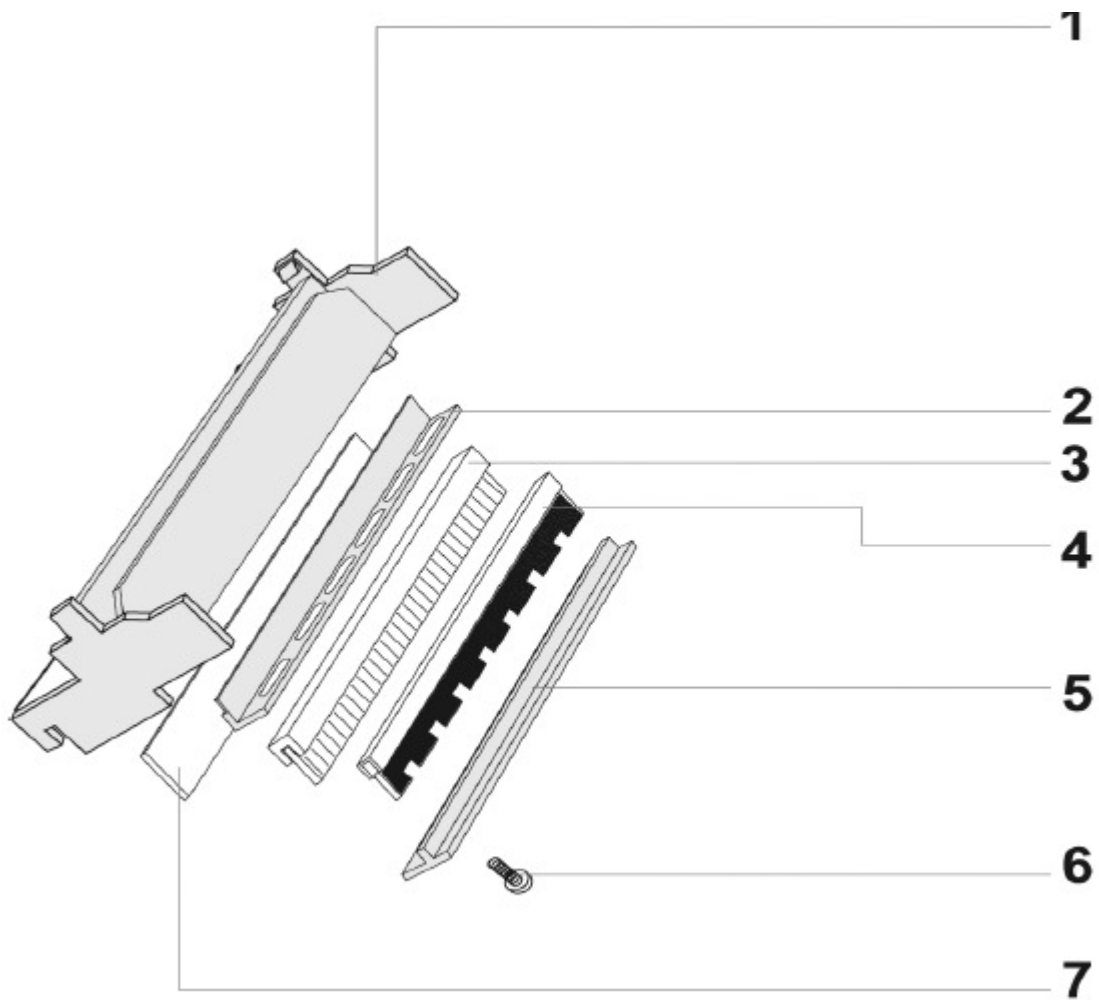

No.	Part#	Description	Qty.
1	S82733	Body, Hard Floor Tool	1
2	S82734	Strip	1
3	S83460	Blade, Hard Floor Tool	1
4	S82748	Brush/Floor Tool	1
5	S83047	Rear Brush, Hard Floor	1
6	S83049	Screw	4
7	S82729	Squeegee Strip	1
1-7	S72707	Complete Wet Pick Up Tool	

Hard Floor Tool JOB Extractor

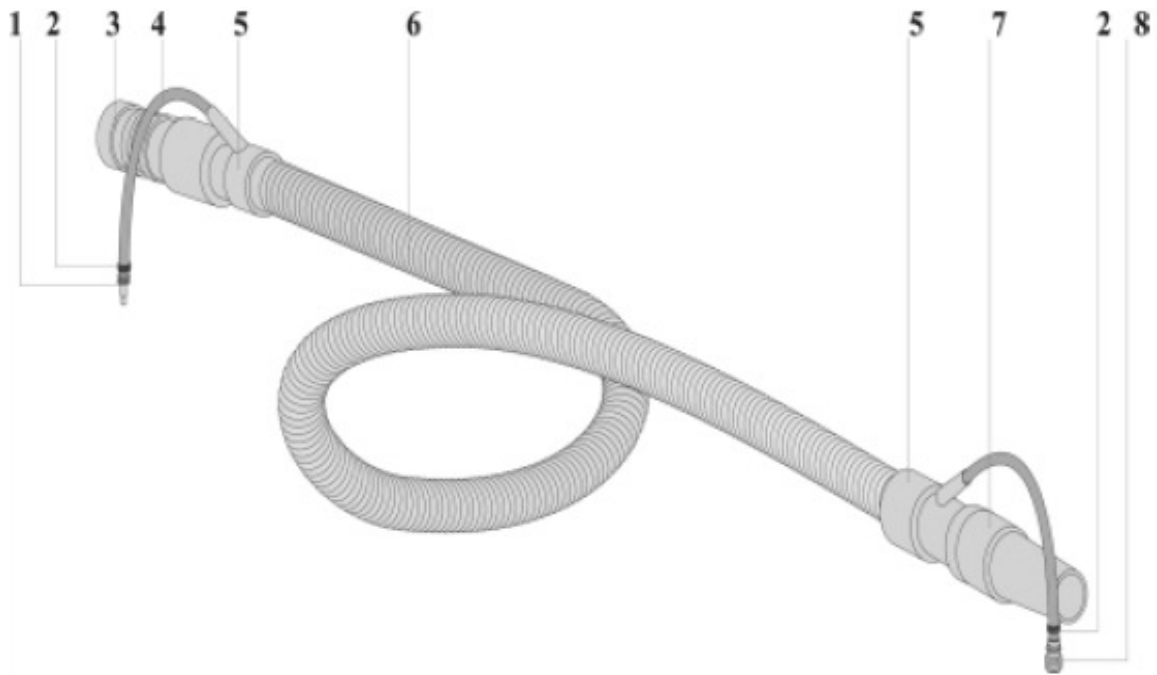

No.	Part#	Description	Qty.
1	S73244	Quick Connect Male	1
2	S83171	Plastic Sleeve	2
3	S70090	Hose Coupling	1
4	S82546	Tube, Solution	1
5	S82547	Hose Coupling	2
6	S70613	Hose, Vacuum	1
7	S70622	Hose Cuff	1
8	S83245RIC	Quick Connect, Female	1
	S72548	Complete Hose Assy.	

Upholstery Tool JOB Extractor

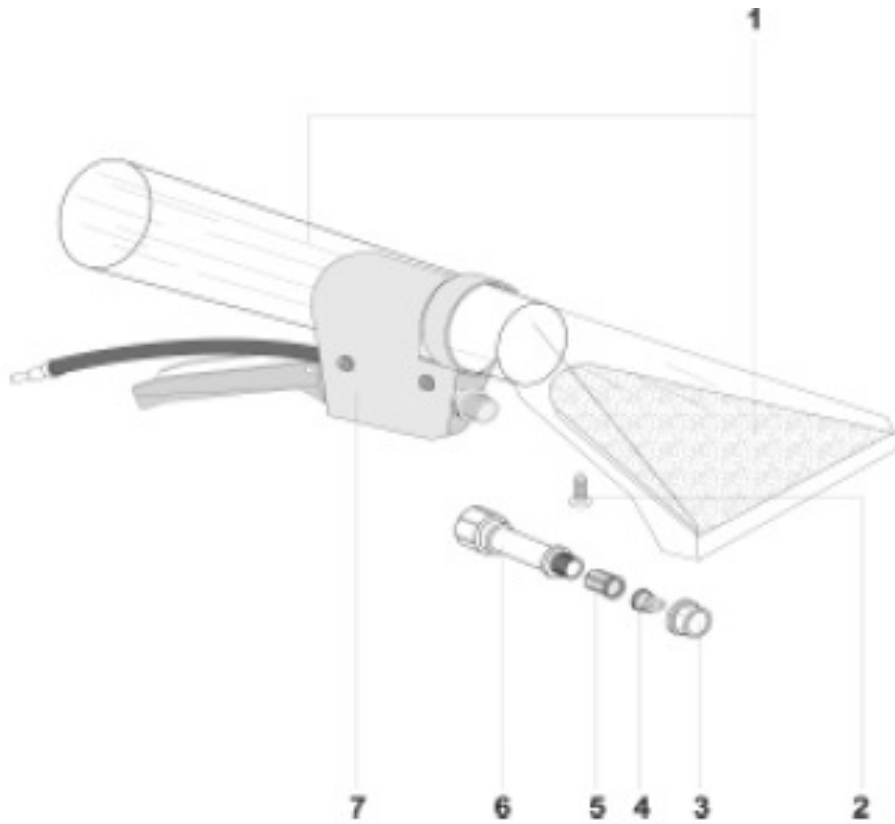

No.	Part#	Description	Qty.
1	S80651	Upholstery Tool, Body	1
2	S83257	Screw	4
3	S82713	Retainer	1
4	S82759	Nozzle, Spray	1
5	S82711	Filter	1
6	S82760	Adapter, Valve	1
7	S86256OTT S70752	Trigger Assy. Complete Upholstery Tool	1

Optional Dry Kit JOB Extractor



No.	Part#	Description	Qty.
1	S70124	Polyester Filter	1
2	S70123	Filter Ring	1
3	S72655	Filter Basket	1
4	S7632B	Double Use Brush	1
5	S70617	Crevice Tool	1
6	S70616	Upholstery Tool	1
7	S70004	Round Dust Brush	1
	S72772	Complete Dry Kit	

Warranty Policy

Limited Warranty

IPC Eagle warrants new cleaning equipment against defects in material and workmanship under normal use and service to the original purchaser as detailed below.

3 years

Subject to the conditions stated below, IPC Eagle warrants all Polyethylene Tanks to be free from defects in materials and workmanship for a 3-year period. Parts replaced or repaired are warranted for the remainder of the original warranty period.

1 year

Subject to the conditions stated below, IPC Eagle warrants all other cleaning equipment components to be free from defects in materials and workmanship for a 1-year period. Parts replaced or repaired are warranted for the remainder of the original warranty period.

IPC Eagle will furnish and charge for replacement parts, including transportation, to the original owner through an IPC Eagle authorized service center. If the part is returned within 30 days and is found defective, the owner will be credited for the cost of the replacement part including shipping and handling.

Labor charges are covered for one year from the date of purchase if provided by an authorized IPC Eagle service center.

Wear items exempt from warranty include belts, carbon brushes, power cords, wheels, brushes, pads, handle grips, filters, screens, hoses, and squeegees.

This warranty shall not apply to failures caused by misuse or abuse, improper maintenance as stated in the operation manuals, use of unauthorized repair parts, repairs by other than an IPC Eagle authorized service center, and damage in transit.

IPC Eagle disclaims and denies any liability for any direct, indirect, special incidental or consequential damage which may be suffered as a result of sale, delivery, servicing, use, loss of any product, downtime, labor, freight, or other charges not expressly included herein.



IPC Eagle

2955 Lone Oak Drive • Eagan, MN 55121
651.686.5399 • Fax 651.686.5695
www.ipceagle.com

IPC Eagle Corporation Sales and Service Provided by: