



Electronic Service Manuals

This electronic document is provided as a service to our customers. We do not create the contents of the information contained in this document. Should you have detailed questions pertaining to the information contained in this document, you may contact Michco, or the manufacturer which provided the original information in this electronic deliverable. Michco's only part in this electronic deliverable was the electronic assembly process. By providing this manual on line we are not guaranteeing parts availability.

You may contact Michco through the following methods:

Phone (517) 484-9312 or (800) 331-3339

2011 N. High St. -- Lansing, Michigan -- 48906

Fax: (517) 484-9836

Email: CustServe@Michco.com

Web site: www.Michco.Com

Parts Web site: www.FloorMachineParts.Com

Order Parts on Line at:

www.FloorMachineParts.Com

Directly to Parts & Service:

By Email: **Shop@Michco.com**

By Fax: (517) 702-2041

By Voice: Use numbers above.

Serving the Cleaning Industry Since 1922

Notice: All copyrighted material remains property of original owners, all trademarks are property of respective owners. Manuals are subject to Manufacturer's reproduction limitations. Originals or reproductions were provided by manufacturers through a request. We make no warranty as to the correctness of information provided in this document and you assume all risk. By placing these manuals on line we are not declaring our corporation to be an manufacturer authorized dealer or provider, please check our web site for authorized manufacturers we represent.

Eagle Power



FASTRACKS BX12 Box Extractor With or Without Heat

OPERATION AND PARTS MANUAL

BEFORE OPERATING THE MACHINE

Read the manual carefully and completely before attempting to operate the unit. This manual has important information for the use and safe operation of the machine. Keep this manual handy at all times. This machine will assure years of satisfactory service if operated and maintained according to recommendations in this manual. If additional information is needed, please contact your local distributor or write to:

Eagle Power Products
1174 Northland Drive
Mendota Heights, MN 55120

WARNING

- The machine was designed for use on carpet, floor and upholstery extraction applications as per instructions and recommendations written in this manual. Any deviation from its proper use or purpose and the consequential damage that may occur is the sole responsibility of the end user.
- Disconnect the power cord from outlet before servicing. Do not leave machine connected to an electrical outlet when unattended.
- Do not immerse or use this machine in standing water. Such use may cause electric shock.
- This equipment is not designed to handle or use combustible/volatile substances such as gasoline or kerosene, in, on, or near the machine. The use of such materials will cause an extreme hazardous condition.
- When using an extension cord, use only a 3 conductor grounding cord - 12 ga. wire or heavier. To avoid electric shock, do not expose the unit to rain - store it indoors only. Do not use the machine for dry vacuuming.
- Use defoamer at all times to prevent damage to the vacuum motor(s).
- Do not use water in excess of 170°F (76°C).
- To prevent seal damage and chemical buildup to the pump system, run clean water through the solution lines after each day's use.
- Use only commercially available carpet cleaning solutions and defoamer intended for use with machines of this type. Do not use dyes, bleaches, ammonia or other additives. The use of powdered cleaning solution if not diluted properly may result in damage to the pump. If powdered chemicals are used, premix in a separate container before placing in the solution tank.
- Do not expose machine to freezing temperatures.
- All repairs must be done by an authorized Eagle Power repair station.
- Do not use replacement parts other than those specified on the parts list.

For units with heat :

- Do not run heater dry.
- Water hookups must be in place and water flowing through the heater prior to turning it on. Failure to do so may cause internal component damage and will void warranty.
- Heater must be filled with water or water based solutions at all times when in use.
- Turn off the switch and unplug the heater from outlet when not in use, allow to cool before cleaning.
- Do not use heater at more than 300 PSI.
- Do not immerse heater in water.
- To avoid explosions and/or fire, do not use solvents or any flammable liquid in heater.

FAILURE TO COMPLY WITH THE ABOVE WARNING INSTRUCTIONS WILL VOID THE WARRANTY

GROUNDING INSTRUCTIONS

The 120 V. A/C and the 220 V. A/C models have been outfitted with the appropriate grounded connectors. Make sure the machine is connected to a grounded outlet having the same configuration as the grounded plug. No adapter should be used with this machine. Any modification to the connectors will void the warranty.

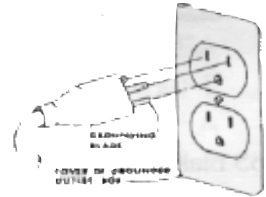

PREPARING THE MACHINE (All Fastracts Equipment)

IMPORTANT: For all Fastracts BX12 equipment, use only the correct Eagle Power high pressure, high heat wands & upholstery tools. They are designed to deliver and maintain the correct gallons per minute (GPM), pressure (PSI) and heat when attached to the Fastracts pump system. Use of other manufacturers wands can cause over-wetting of carpet, damage to the pump system (including hose & fittings), lack of pressure and heat.

1. Pour clean solution into the solution tank.
2. Slide vacuum hose on to the black hose adapter (located at the back of machine) and the wand or upholstery tool.
3. Connect the male end of the solution hose to the wand and the female end to the machine by sliding knurled collar on the female quick disconnect fitting back. Push the male fitting in and release the knurled collar until it snaps back.
4. Make sure the drain valve is closed by pushing the T-handle all the way in.
5. Previously shampooed carpets usually have a heavy build-up of old shampoo residue which can cause the vacuum system to ingest foam and result in damage to the vacuum motor. Remember to add recommended amount of defoamer to the recovery tank every time you fill the solution tank.
6. If a Powermate (Models 1204AC & 1800AC-100) is to be used with the machine, connect the male plug on the wand to the optional receptacle on the machine.

For Fastracts BX12 with heat, see additional instructions below.

Additional instructions for **BX12 with heat:**

1. Be sure to fill solution tank with water before plugging in machine.
2. Plug heater power cord and machine power cord into separate outlets on separate circuits.
3. turn on heater switch when you are ready to clean.
4. **CAUTION:** When the green light on the heater is on, the heater is heating. When the green light is off, the water in the heater tank is up to temperature and the thermostat switch in the heater has turned the heater off. It will automatically turn on again when the water temperature in the heater has cooled.

OPERATING INSTRUCTIONS - CARPET TOOL

1. Turn on the vacuum and solution switches. Slowly pull the tool towards you with the solution valve trigger engaged. Then make a pass forward and backward with the vacuum only (no spray) over the cleaned area to remove as much dirt and solution as possible. Do not overwet carpet! Make overlapping passes to prevent streaking.
2. If the carpet is heavily soiled, squeeze solution valve lever on the forward pass as well as backwards, allowing cleaning solution a few seconds longer to work prior to vacuuming. Another method is to raise the wand 8" above the carpet and pre-spray lightly prior to cleaning passes. On extremely soiled carpets, we recommend using a pre-spray solution.
3. When you run out of solution, turn off the pump. Attach the drain elbow on the drain valve. Place a pail under the downspout and pull up the drain valve T-handle. Dirty solution will pour out until the tank is empty. Close the drain valve. Use a clean bucket when you refill the solution tank.
4. When the job is completed, turn the switches off, disconnect the vacuum and solution hoses from the carpet tool and the machine. Drain the recovery tank through the drain valve as before.

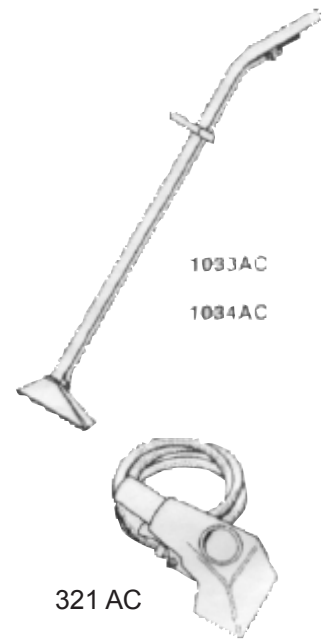

CLEANING UPHOLSTERY

Cleaning upholstery with success requires a good knowledge of the type of fabric to be worked on. Look for the cleaning instruction label sewn on the underside of the furniture for the recommended method of cleaning the fabric. If it calls for dry cleaning, do not attempt to clean with the wet extraction method. Otherwise, damage to the fabric could occur. Extraction works perfectly on most synthetic fabrics including synthetic velvets.

Before proceeding, test the fabric for color fastness. Apply a small amount of ready-to-use cleaning solution on the fabric in an inconspicuous spot. Wait for 2 to 3 minutes and rub the area with a white terry cloth towel. If no color comes off the towel, the fabric should be safe to clean. If a little color comes off, there is some risk of colors running when you clean. It may be possible to stabilize colors by cleaning with an acidic rinse.

1. Prepare the machine in the same manner as for carpet (see preparing the machine) cleaning except attach the upholstery tool to the vacuum hose. Connect the solution hose. Pour hot water into the solution tank. Add recommended amount of cleaning concentrate into the solution tank. Turn on the vacuum and pump switches.
2. Adjust the pump "operating pressure" to 50 psi or below for upholstery cleaning (See page 3 PREPARING THE MACHINE items 8 and 9).
3. Clean with the upholstery tool using as little solution as possible. Make overlapping passes to prevent streaking. Go over the area you just cleaned without depressing the lever (vacuum only) and gauge the amount of moisture extracted through the view window for dryness. On heavily soiled areas like arm rests, pre-treat with a recommended pre-spray and /or hold the upholstery tool a few inches above the fabric and press lever to spray on the solution before making a pass.

DAILY MAINTENANCE

1. Always keep the machine clean inside and out.
2. Pour 2 gallons of clean hot water in the solution tank. Turn the pump on and flush the entire system through the wand nozzles for about a minute to prevent alkaline build-up.
3. Remove dirt and lint build-up inside the filter screen in the recovery tank. Lint should be cleaned off so that air flow is not impeded.
4. Check the solution tank strainer in the solution tank. If lint has accumulated in the screen, remove and rinse it in clear running water.

PERIODIC MAINTENANCE

All Eagle Power machines are engineered and built to require a minimum of maintenance. But like any machine, it does require some care to keep it in optimum working condition. Careful attention to these maintenance instructions will give you maximum operating performance and will increase the life expectancy of your machine.

- **Solution Lines and Fittings.** Flush the machine at least once a month with a solution of 1 part water with 3 parts white vinegar in order to neutralize the alkaline residue left by the cleaning solution.
- **Quick connect coupler.** Spray with WD-40 or equivalent lubricant to prevent coupler from sticking.
- **Drain Valve.** Apply light oil on gate seals. If machine has to be stored, leave the gate valve open.
- **Solution pump.** The same above procedure used on solution line and fittings applies to the pump.

TROUBLESHOOTING

ELECTRICAL SYSTEM

Problem	Possible Cause
No electrical power.	1. Defective power cord. 2. House or building circuit breaker tripped.
Switch is turned on. Power is intermittent to all motor(s)	1. Faulty electrical cable. 2. Defective switches. 3. Loose terminal or discolored terminal connections.

VACUUM SYSTEM

No Vacuum	1. Drain Valve open. 2. Vacuum lid is not sealed against tank. 3. Loose vacuum hose, vacuum connection.
Low Vacuum	1. Accumulated dirt on lid screen. 2. Worn out vacuum lid gasket. 3. Lint and dirt build-up on wand head. 4. Defective vacuum hose. 5. Loose connection in the vacuum motor(s).

SOLUTION SYSTEM

Pump motor on, no spray thru spray tips	1. Clogged spray tips. 2. Clogged solution intake filter screen. 3. Plugged female quick disconnect coupler. 4. Punctured pump diaphragm. (100 psi only) 5. Defective pump check valve. (100 psi only) 6. Crack in pump housing. 7. Debris in check valve. (100 psi only) 8. Lost Prime.
Uneven or weak spray from tips.	1. Clogged or dirty spray tips. 2. Accumulated dirt on solution intake filter screen. 3. Accumulation of debris inside pump and plumbing. 4. Worn pump bearing (excessive noise). 5. Punctured pump diaphragm. 6. Defective rectifier or motor. 7. Worn nozzles.
Vacuum motor(s) working, pump motor Fails to turn on	1. Loose wiring connection. 2. Defective pressure switch in pump (100 psi model). 3. Defective pump motor or rectifier.

OPTIONAL ACCESSORIES

HEAT-N-RUN

Inline heater delivering up to 200°F heat enhancing productivity and cleaning. Model 61OHR

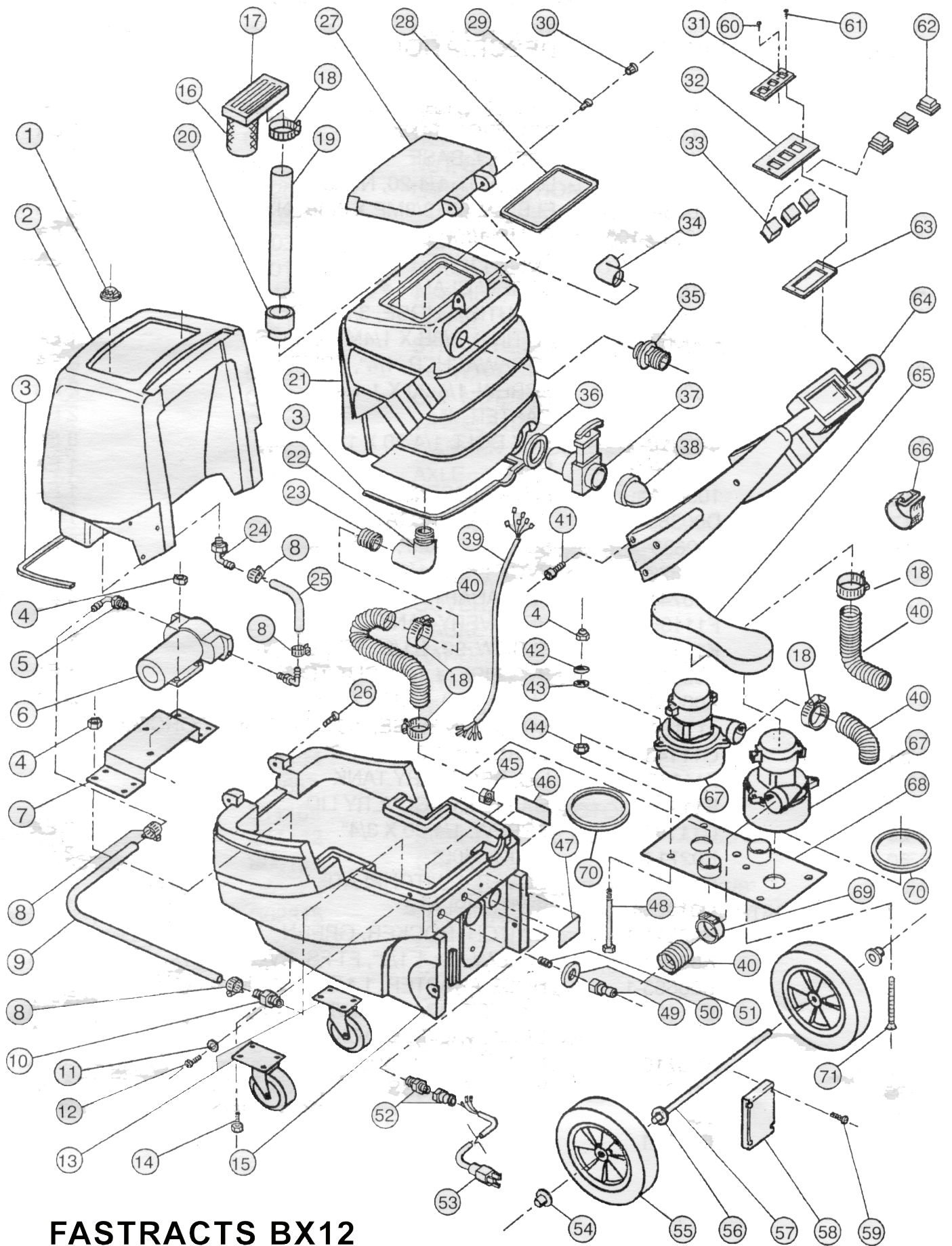

**FASTRACTS BX12
PARTS DIAGRAM**

FASTRACTS BX12 PARTS LIST

ITEM #	PART #	DESCRIPTION	QTY
1	D00373	INLET FILTER, 1/4NPT	1 EA
2	F11137	SOLUTION TANK	1 EA
3	E11129	GASKET, BASE	5 FT
4	000273	LOCKNUT, 1/4-20, NYLON	16 EA
5	A00054	ELBOW, 90, 3/8MP X 3/8B, NYLON	2 EA
6	G00513-100	PUMP, 100PSI	1 EA
7	D11194	PUMP PLATE	1 EA
8	J11508	SCREW CLAMP, #6	4 EA
9	J00613G	SOLUTION HOSE, 3/8", GREY	2.75 FT
10	A00060	FITTING, 3/8B X 1/4MP, BRASS	1 EA
11	000254	LOCKWASHER, 1/4", SPLIT	8 EA
12	C02294	SCREW, 1/4-20 X 1 1/4"	2 EA
13	G03518	CASTER, 4"	2 EA
14	000314-1	HEX BOLT, 1/4-20 X 1"	8 EA
15	FI 1139-B	BASE	1 EA
16	10989A	FLOAT ASSEMBLY	1 EA
17	D00385-7	VAC DUCT, FLOAT	1 EA
18	J00639	SCREW CLAMP, 2"	5 EA
19	K00672	PVC PIPE, 1 1/2"	1.60 FT
20	K00741	PIPE ADAPTER, 1 1/2"	1 EA
21	FI 1138	RECOVERY TANK	1 EA
22	K11185	ELBOW, 90, 1 1/2", MT MS, PVC	1 EA
23	K00672-1	PVC PIPE, 1 1/2", CUT TO 2"	1 EA
24	A00051	ELBOW, 90, 1/4MP X 3/8B, NYLON	1 EA
25	J11154	SOLUTION HOSE, 3/8", WIRE REINFORCED	1.33 FT
26	C11143	SCREW, 1/4-20 X 1 1/2"	2 EA
27	F11135	LID, RECOVERY TANK	1 EA
28	E11124	GASKET, RECOVERY LID	1 EA
29	C11167	SCREW, 1/4-20 X 3/4"	2 EA
30	K02714	PLUG, .500"	2 EA
31	D11168	COVER, SWITCHPLATE	1 EA
32	D010284	SWITCHPLATE	1 EA
33	B02211-1	SWITCH, ROCKER, GREEN	3 EA
34	K00666	ELBOW, 90, 1 1/2", FT FS, PVC	1 EA
35	K00665-1	HOSE ADAPTER, 1 1/2", BLACK	1 EA
36	E11128	GASKET, DRAIN VALVE	1 EA
37	K00711	DRAIN VALVE, BLACK	1 EA
38	K00710	ELBOW, DRAIN VALVE	1 EA
39	B010314	WIRE HARNESS	1 EA
40	J00618	VACUUM HOSE, 2", WIRE REINFORCED	4.5 FT
41	C11141	SCREW, ALLEN HEAD, 1/4-20 X 1 1/4"	8 EA

GALAXY 2000SX PARTS LIST

ITEM #	PART #	DESCRIPTION	QTY
42	000233	WASHER, 1/4", FLAT	16 EA
43	E00449	GROMMET	6 EA
44	C00261	HEX NUT, 1/4-20	12 EA
45	B00201	NUT, STRAIN RELIEF	1 EA
46	H02564-2	LABEL, CAUTION	1 EA
47	H00565-5	LABEL, SERIAL NUMBER	1 EA
48	C00319	HEX BOLT, 1/4-20 X 3 1/2"	5 EA
49	A00104	QUICK DISCONNECT, 1/4" MALE	1 EA
50	011244	WASHER, 1/2"ID X 1 1/2" OD	2 EA
51	A00111	NIPPLE, 1/4"	1 EA
52	B02213	STRAIN RELIEF	1 EA
53	B00221-1	POWER CORD, 12/3,25'	1 EA
54	C02305	CAP NUT, 1/2"	2 EA
55	G010313	WHEEL, 10"	2 EA
56	000240	WASHER, SHOULDER, NYLON	2 EA
57	D11170	AXLE	1 EA
58	FI 1173-B	HEATER TUNNEL COVER	1 EA
59	C11165	SCREW, #8 X 1"	4 EA
60	000293	SCREW, #8 X 1/2", BLACK	2 EA
61	000295-1	SCREW, #10 X 3/4", BLACK	2 EA
62	B00214-2	COVER, SWITCH	3 EA
63	E010453	GASKET, SWITCHPLATE	1 EA
64	FI 1136-B	HANDLE	1 EA
65	FI 1178-BLK	INTERCOOLER	1 EA
66	011177	VELCRO STRAP	1 EA
67	G00537	VACUUM MOTOR, 82", 115V	2 EA
68	D11134	VAC PLATE	1 EA
69	J00657	HOSE CLAMP, 2"	1 EA
70	E11169	GASKET, VAC MOTOR	2 EA
71	011142	SCREW, 1/4-20 X 3 1/2", FLATHEAD	1 EA
NOT SHOWN	B00187	CABLE CLAMP	1 EA
NOT SHOWN	000284	GROUNDING SCREW, 10-32 X 3/8"	2 EA
NOT SHOWN	C02315	LOCKWASHER, #10, INTERNAL STAR	2 EA
NOT SHOWN	H02548-2	LABEL, "IMPORTANT THIS EQUIPMENT..."	1 EA
NOT SHOWN	H03545	COVER, SERIAL TAG	1 EA
NOT SHOWN	H11171	LABEL, GALAXY	1 EA
NOT SHOWN	L11149	BOX	1 EA

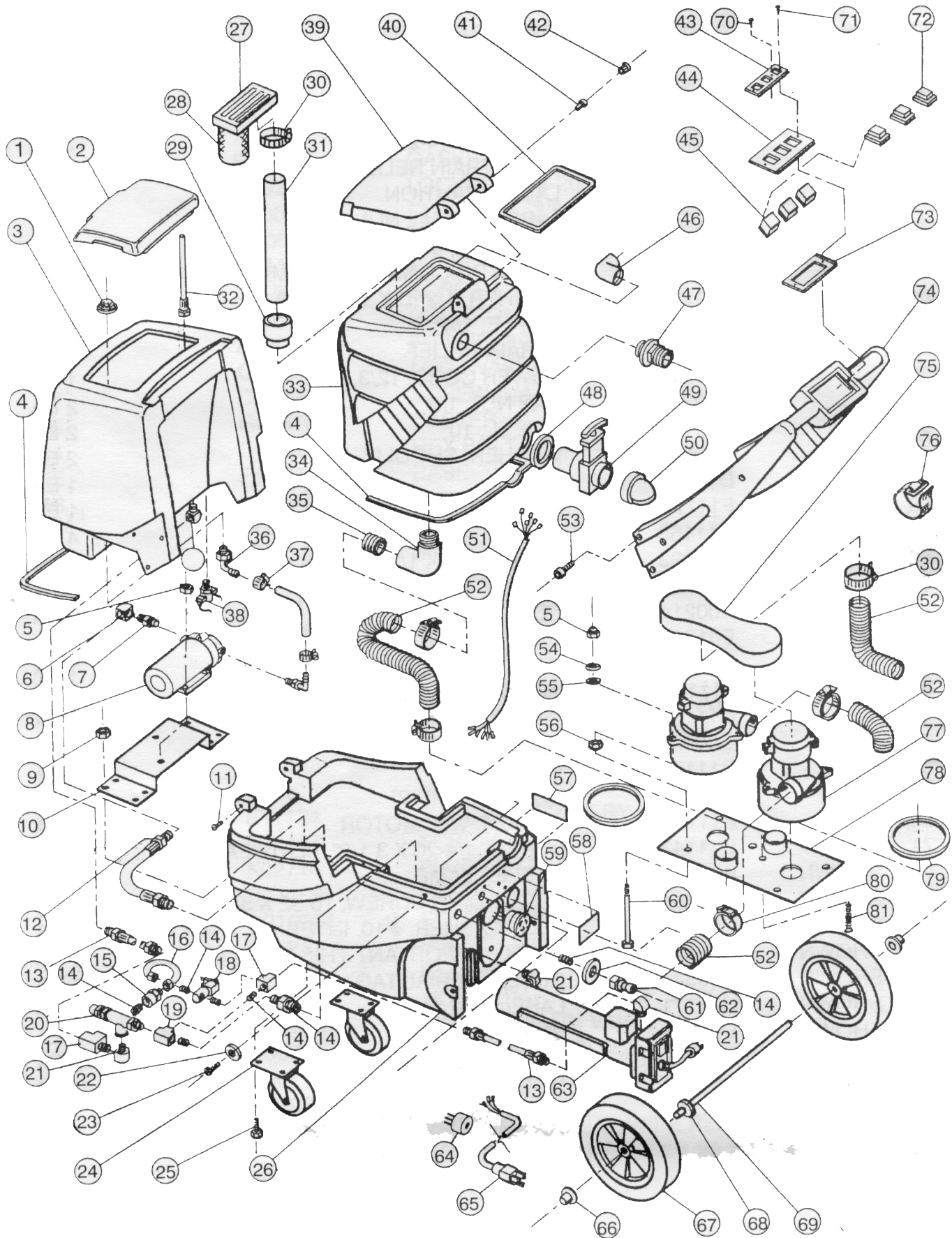

**FASTRACTS BX12 W/HEAT
PARTS DIAGRAM**

FASTRACTS BX12 W/HEAT PARTS LIST

ITEM #	PART #	DESCRIPTION	QTY
1	D00373	INLET FILTER, 1/4NPT	2 EA
2	FI 1275	LID, SOLUTION TANK	1 EA
3	F11264	SOLUTION TANK	1 EA
4	E11129	GASKET, BASE	5 FT
5	C00261	HEX NUT, 1/4-20	12 EA
6	A00154	ELBOW, 90, 1 /4FP X 1 /4FP, BRASS	1 EA
7	A00168	BUSHING, 3/8MP X 1/4FP	1 EA
8	G00513-100	PUMP, 100PSI	1 EA
9	C00273	LOCKNUT, 1/4-20	16 EA
10	D11194	PUMP PLATE	1 EA
11	011143	SCREW, 1/4-20 X 1 1/2"	2 EA
12	J00660	SWAGE FITTING, 1/4FP X 1/4HOSE	4 EA
13	J00659	SWAGE FITTING, 1/4MP X 1/4HOSE	2 EA
14	A00111	NIPPLE, 1/4"	8 EA
15	A00121	FITTING, 1/4MP X 1/4FP, BRASS	1 EA
16	A00085-21	TUBE, PRESSURE REGULATOR	1 EA
17	A11589	TEE, 1 /4M P X 1 /4FP X 1 /4FP	2 EA
18	G02536	SOLENOID	1 EA
19	A00161	TEE, 1 /4FP X 1 /4FP X 1 /4FP	4 EA
20	G11314	PRESSURE REGULATOR	1 EA
21	A00052	ELBOW, 90, 1 /4FP X 1 /4MP, BRASS	6 EA
22	C00254	LOCKWASHER, 1/4:, SPLIT	8 EA
23	C02294	SCREW, 1/4-20 X 1 1/4"	2 EA
24	G03518	CASTER; 4"	2 EA
25	000314-1	HEX BOLT, 1/4-20 X 1"	8 EA
26	FI 1139-B	BASE	1 EA
27	D00385-7	VAC DUCT, FLOAT	1 EA
28	10989A	FLOAT ASSEMBLY	1 EA
29	K00741	PIPE ADAPTER, 1 1/2"	1 EA
30	J00639	SCREW CLAMP, 2"	5 EA
31	K00672	PVC PIPE, 1 1/2"	1.60 FT
32	J00580	HOSE, 1/4", HIGH PRESSURE	4 FT
33	F11138	RECOVERY TANK	1 EA
34	K11185	ELBOW, 90,1 1/2", MT MS, PVC	1 EA
35	K00672-1	PVC PIPE, 1 1/2", CUT TO 2" LENGTH	1 EA
36	A00051	ELBOW, 90, 1/4MP X 3/8B, NYLON	2 EA
37	J11508	SCREW CLAMP, #6	6 EA
38	G11272	THERMOSTAT, 150DEG.	1 EA
39	F11135	LID, RECOVERY TANK	1 EA
40	E11124	GASKET, RECOVERY LID	1 EA
41	C11167	SCREW, 1/4-20 X 3/4"	2 EA
42	K02714	PLUG, .500"	2 EA
43	D11168	COVER, SWITCHPLATE	1 EA

FASTRACTS BX12 W/HEAT PARTS LIST

ITEM #	PART #	DESCRIPTION	QTY
44	DO 10284	SWITCHPLATE	1 EA
45	B02211-1	SWITCH, ROCKER, GREEN	3 EA
46	K00666	ELBOW, 90,1 1/2", FT FS, PVC	1 EA
47	K00665-1	HOSE ADAPTER, 1 1/2", BLACK	1 EA
48	E11128	GASKET, DRAIN VALVE	1 EA
49	K00711	DRAIN VALVE, BLACK	1 EA
50	K00710	ELBOW, DRAIN VALVE	1 EA
51	B010314	WIRE HARNESS	1 EA
52	J00618	VACUUM HOSE, 2", WIRE REINFORCED	4.5 FT
53	C11141	SCREW, ALLEN HEAD, 1/4-20 X 1 1/4"	8 EA
54	C00233	WASHER, 1/4", FLAT	16 EA
55	E00449	GROMMET	6 EA
56	C00261	HEX NUT, 1/4-20	12 EA
57	H02564-2	LABEL, CAUTION	1 EA
58	H00565-5	LABEL, SERIAL NUMBER	1 EA
59	B11304	TWIST LOCK RECEPTACLE	1 EA
60	C00319	HEX BOLT, 1/4-20 X 3 1/2"	5 EA
61	A00104	QUICK DISCONNECT, 1/4" MALE	1 EA
62	C11244	WASHER, 1/2"ID X 1 1/2" OD	2 EA
63	630HR	HEATER, AUTOMOTIVE	1 EA
64	B11452	TWIST LOCK CONNECTOR	1 EA
65	B00221-1	POWER CORD, 12/3,25'	1 EA
66	C02305	CAP NUT, 1/2"	2 EA
67	G010313	WHEEL, 10"	2 EA
68	000240	WASHER, SHOULDER, NYLON	2 EA
69	D11170	AXLE	1 EA
70	000293	SCREW, #8 X 1/2", BLACK	2 EA
71	000295-1	SCREW, #10 X 3/4", BLACK	2 EA
72	B00214-2	COVER, SWITCH	3 EA
73	E01 0453	GASKET, SWITCHPLATE	1 EA
74	FI 1136-B	HANDLE	1 EA
75	FI 1178-BLK	INTERCOOLER	1 EA
76	C11177	VELCRO STRAP	1 EA
77	G00537	VACUUM, 82", 115V	2 EA
78	D11134	VAC PLATE	1 EA
79	E11169	GASKET, VAC MOTOR	2 EA
80	J00657	HOSE CLAMP, 2 "	1 EA
81	011142	SCREW, 1/4-20 X 3 1/2", FLATHEAD	1 EA
NOT SHOWN	1040AC-H P	HOSE ASSY, 15', HIGH PRESSURE	1 EA
NOT SHOWN	H11171	LABEL, GALAXY	1 EA
NOT SHOWN	L11149	BOX	1 EA
NOT SHOWN	L11294	CARDBOARD INSERT	2 EA
NOT SHOWN	S11179	NON-SKID TAPE	0.50 FT
NOT SHOWN	ZF1202	OWNERS MANUAL	1 EA



Warranty Policy

Limited Warranty

Eagle Power Products (EPP) warrants new cleaning equipment against defects in material and workmanship under normal use and service to the original purchaser as detailed below.

10 Years

Subject to the conditions stated below, EPP warrants polyethylene tanks and housings to be free from defects in materials and workmanship for a period of ten years.

3 Years

Subject to the conditions stated below, EPP warrants all automatic scrubber components to be free from defects in materials and workmanship for a 3-year period. Parts replaced or repaired are warranted for the remainder of the original warranty period.

1 Year

Subject to the conditions stated below, EPP warrants all other cleaning equipment components to be free from defects in materials and workmanship for a 1-year period. Parts replaced or repaired are warranted for the remainder of the original warranty period. Batteries are prorated for one year.

EPP will furnish and charge for replacement parts, including transportation, to the original owner through an EPP authorized service center. If the part is returned within 30 days and is found defective, the owner will be credited for the cost of the replacement part including shipping and handling.

Labor charges are covered for one year from the date of purchase if provided by an authorized EPP service center. Travel is covered for 90 days for battery operated equipment only.

Wear items exempt from warranty include belts, carbon brushes, power cords, wheels, pad drivers, clutch plates, brushes, pads, handle grips, filters, screens, throttle cables, and squeegees.

This warranty shall not apply to failures caused by misuse or abuse, improper maintenance as stated in the operation manuals, use of unauthorized repair parts, repairs by other than an EPP authorized service center, and damage in transit.

EPP disclaims and denies any liability for any direct, indirect, special incidental or consequential damage which may be suffered as a result of sale, delivery, servicing, use, loss of any product, downtime, labor, freight, or other charges not expressly included herein.

Date Purchased: _____

Serial Number: _____

Serial Number: _____

Please be sure to record this information. This information will be necessary for future warranty claims.



1174 Northland Drive Mendota Heights, MN 55120
651.686.5399 Fax 651.686.5695
www.eaglepower.com

Eagle Power Products Sales and Service Provided by: