



Electronic Service Manuals

This electronic document is provided as a service to our customers. We do not create the contents of the information contained in this document. Should you have detailed questions pertaining to the information contained in this document, you may contact Michco, or the manufacturer which provided the original information in this electronic deliverable. Michco's only part in this electronic deliverable was the electronic assembly process. By providing this manual on line we are not guaranteeing parts availability.

You may contact Michco through the following methods:

Phone (517) 484-9312 or (800) 331-3339

2011 N. High St. -- Lansing, Michigan -- 48906

Fax: (517) 484-9836

Email: CustServe@Michco.com

Web site: www.Michco.Com

Parts Web site: www.FloorMachineParts.Com

Order Parts on Line at:

www.FloorMachineParts.Com

Directly to Parts & Service:

By Email: **Shop@Michco.com**

By Fax: (517) 702-2041

By Voice: Use numbers above.

Serving the Cleaning Industry Since 1922

Notice: All copyrighted material remains property of original owners, all trademarks are property of respective owners. Manuals are subject to Manufacturer's reproduction limitations. Originals or reproductions were provided by manufacturers through a request. We make no warranty as to the correctness of information provided in this document and you assume all risk. By placing these manuals on line we are not declaring our corporation to be an manufacturer authorized dealer or provider, please check our web site for authorized manufacturers we represent.

Eagle Power™

Products Group



SK24

AUTOMATIC

SCRUBBER

ENTER 

PARTS MANUAL



Click on icon to
return to this page.

← Back 1 page

SK 24 AUTOMATIC SCRUBBER CODE: PF02270NTG-4 aa SN from 01E635

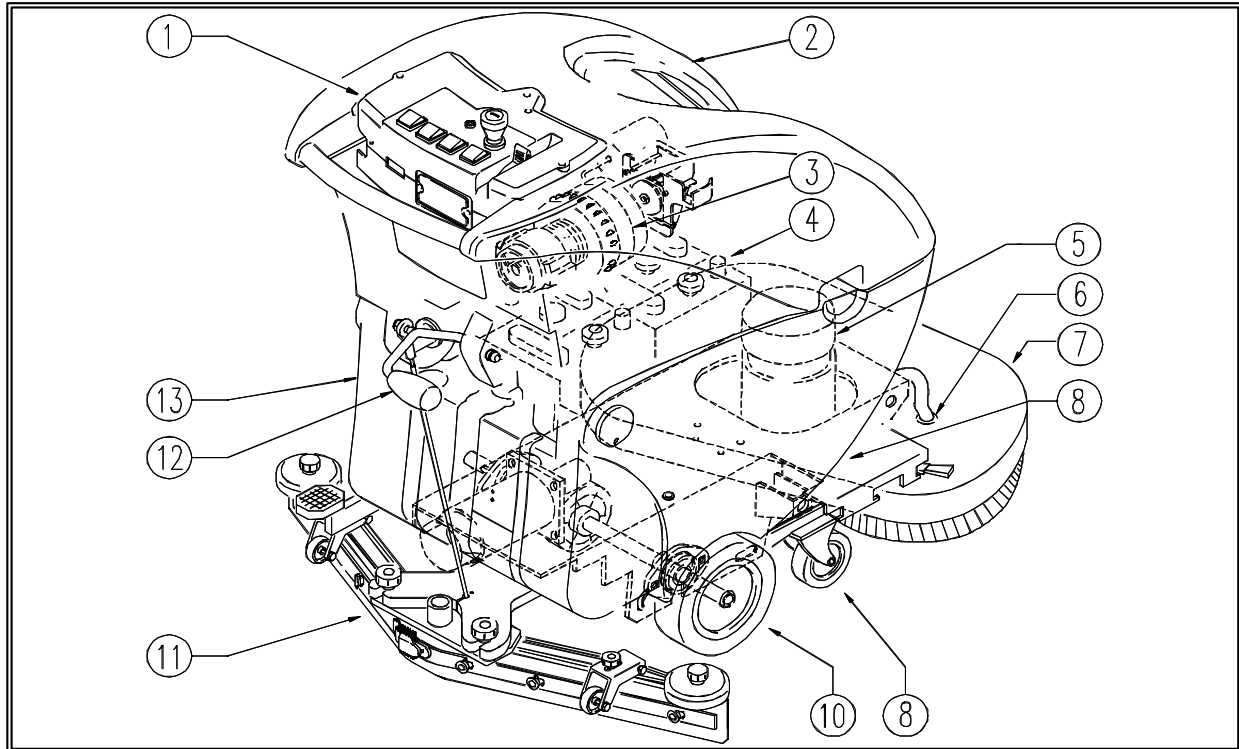

REF.	CODE	DESCRIPTION	QTY
1	PL1340	CONTROL PANEL	
2	PL1012	TANK	
3	PL1001	SUCTION UNIT	
4	PL1347	ELECTRIC UNIT	
5	PL1455	HEAD: MOTOR	
6	PL1337	HEAD: AXLE PULLEY	
7	PL1456	HEAD: FLAP	
8	PL1341	FRAME - TRANSPORT SYSTEM	
10	PL1343	DRIVE UNIT	
11	PL1010	SQUEEGEE	
12	PL1345	SQUEEGEE SUPPORT	
13	PL1346	TANK	
15	PL1457	BRUSHES	
16	PL1339N	EXTERNAL PARTS	
17	PL1458N	PACKING	
	WD27193	ELEC. WIRING DIAGRAM	
	WD27193-1	ELEC. SCHEMATIC DIAGRAM	



← Back 1 page

SK 24 AUTOMATIC SCRUBBER CODE: pl1340 ab SN from 02A000

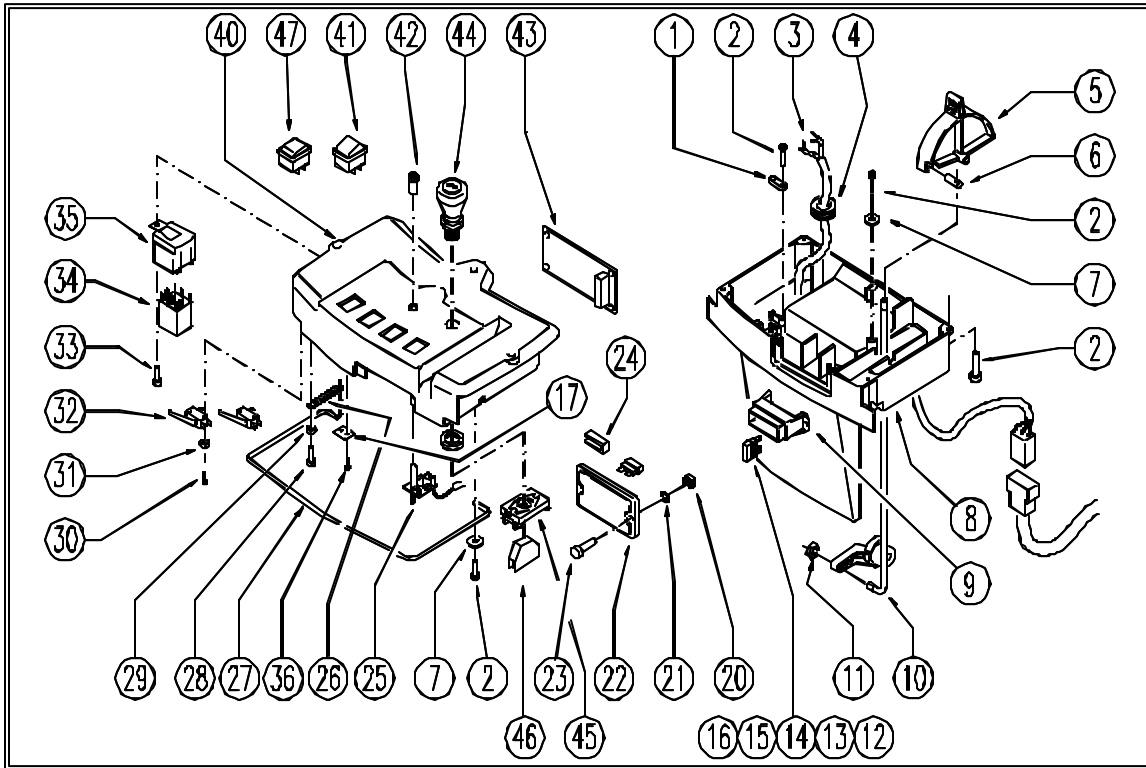

SK 24 AUTOMATIC SCRUBBER CODE: pl1340 ab SN from 02A000

REF.	CODE	DESCRIPTION	QTY
	GR23715-4	PREASSEMBLED CTRL PANEL	1
1	SL09908	CABLE CLAMPING STAPLE	1
2	SL04187	SCREW	8
3	SL23733	WIRING	1
4	SL23695	FAIRLEAD	1
5	SL17490-1	LEVER	1
6	SL09808	ARTICULATION	1
7	SL06038	WASHER	2
8	SL17489-1	CONTROL PANEL	1
9	SL23894	FUSE CARRIER	1
10	SL09805	ROD	1
11	SL05041	NUT	1
12	SL23144	FUSE	2
13	SL23148	FUSE	2
14	SL23148	FUSE	2
15	SL23144	FUSE	2
16	SL23148	FUSE	1
17	SL09955	SUPPORT	1
20	SL05077	NUT	2
21	SL03116	GASKET	2
22	SL17149-1	LID	1

Next page →



← Back 1 page

SK 24 AUTOMATIC SCRUBBER CODE: pl1340 ab SN from 02A000			
REF.	CODE	DESCRIPTION	QTY
23	SL04377	SCREW	2
24	SL23209	FUSE TWEEZERS	1
25	SL23031	BOARD / CARD	1
26	SL13116	SPRING	1
27	SL09795	LEVER	1
28	SL04215	SCREW	3
29	SL06019	WASHER	1
30	SL04214	SCREW	6
31	SL06009	WASHER	4
32	SL23109	MICROSWITCH	2
33	SL04226	SCREW	1
34	SL23719	RELAIS	1
35	SL23722	RELAIS SUPPORT	1
36	SL04327	SCREW	2
40	SL17488-1	CONTROL PANEL	1
41	SL23183	SWITCH	2
42	SL23031-1	REFLEX REFLECTOR	1
43	SL23731-2	GEARCASE / BOARD	1
44	SL23954	EMERGENCY SWITCH	1
45	SL23955	CONTACT CARRIER	1
46	SL23956	CONNECTION	2
47	SL23570	SWITCH COVER	2



← Back 1 page

SK 24 AUTOMATIC SCRUBBER CODE: pl1012 ah SN from 01K187

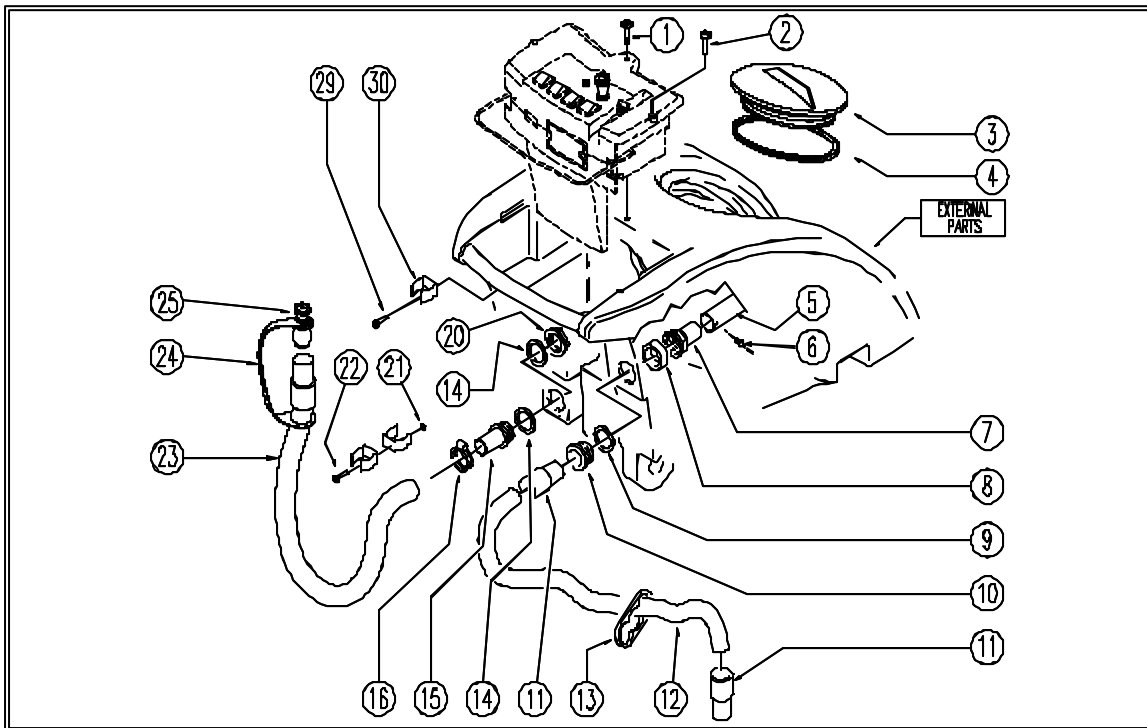

SK 24 AUTOMATIC SCRUBBER CODE: pl1012 ah SN from 01K187

REF.	CODE	DESCRIPTION	QTY
1	SL14162	KLIP	1
2	SL04377	SCREW	2
3	SL17468	COVER	1
4	SL03487	GASKET	1
5	SL07420	HOSE	1
6	SL04325	SCREW	1
7	SL18349	CONNECTOR	1
8	SL07546	SPACER	1
9	SL03416	GASKET	1
10	SL18355	SUCTION OPENING	1
11	SL14003	SLEEVE	2
12	SL19021	HOSE	1
13	SL03437	PLAQUE	1
14	SL03441	GASKET	2
15	SL18350	CONNECTOR	1
16	SL14063	CLAMP	1
20	SL05075	NUT	1
21	SL05044	NUT	2
22	SL04032	SCREW	2
23	SL19113-5	HOSE	1
24	SL03577	CLAMP	1
25	SL18395	KNOB	1
29	SL04371	SCREW	2
30	SL13118	DUCT LOCK	3



← Back 1 page

SK 24 AUTOMATIC SCRUBBER CODE: pl1001 ae SN from 01B600

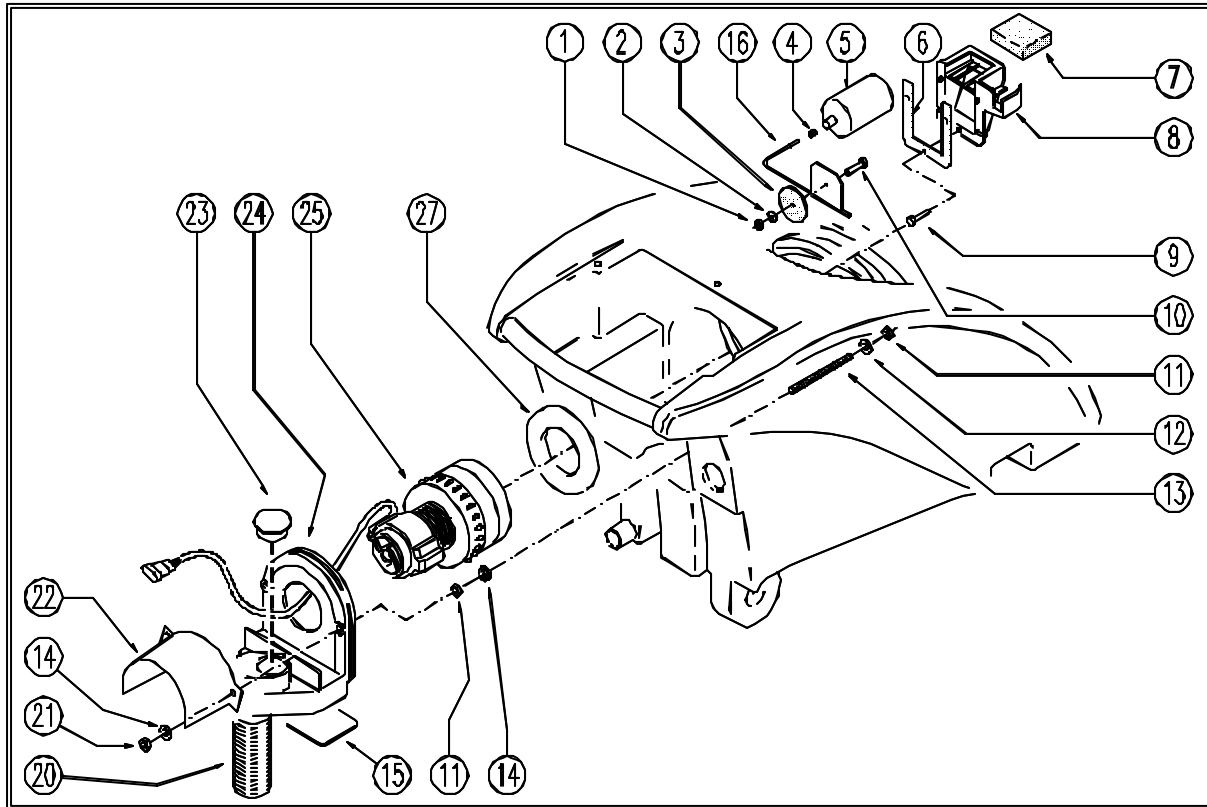

REF.	CODE	DESCRIPTION	QTY
1	SL05087	NUT	1
2	SL06038	WASHER	1
3	SL03346	GASKET	1
4	SL04388	INSERT	1
5	SL18393	FLOAT	1
6	SL03429	GASKET	1
7	SL03345	FILTER	1
8	SL17492-1	SUPPORT	1
9	SL04095	SCREW	3
10	SL04310	SCREW	1
11	SL05017	NUT	4
12	SL06071	WASHER	2
13	SL04276	SCREW	2
14	SL06022	WASHER	4
15	SL17554	BULKHEAD	1
16	SL09827	ROD	1
20	SL19248	PIPE	1
21	SL05041	NUT	2
22	SL03514	SUCTION CONVEYOR	1
23	SL14240	CAP	1
24	SL03297	CAP / SHELL	1
25	SL02303-J	EXHAUSTER / ASPIRATOR	1
27	SL03033	GASKET	1



← Back 1 page

SK 24 AUTOMATIC SCRUBBER CODE: p11347 ab SN from 01B600

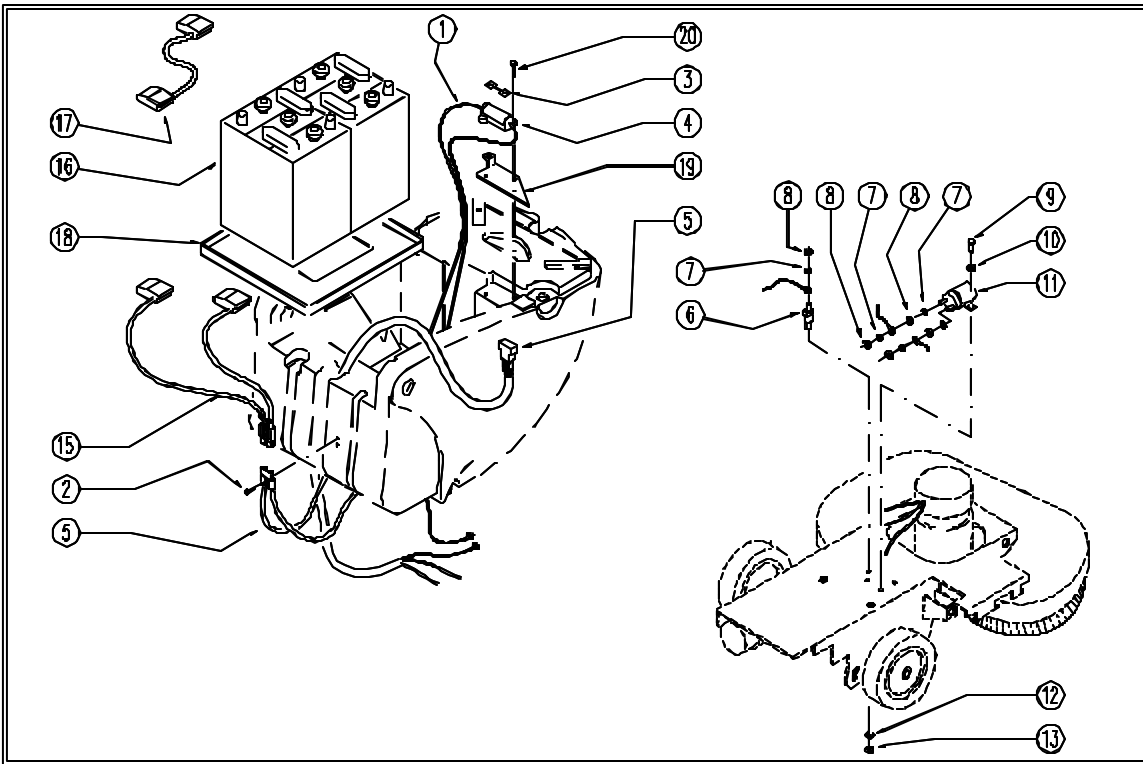

SK 24 AUTOMATIC SCRUBBER CODE: p11347 ab SN from 01B600

REF.	CODE	DESCRIPTION	QTY
1	SL23630	WIRING	1
2	SL04016	SCREW	2
3	SL23696	FUSE	1
4	SL23697	FUSE CARRIER	1
5	SL23629	WIRING	1
6	SL23103	SUPPORT	1
7	SL06002	WASHER	5
8	SL05004	NUT	5
9	SL04108	SCREW	2
10	SL06038	WASHER	2
11	SL23001	REMOTE CONTROL SWITCH	1
12	SL06087	WASHER	1
13	SL05039	NUT	1
15	SL23628	WIRING	1
16	AL03122	BATTERY	2
17	SL23838	BRIDGE / JUMPER	1
18	SL17162-1	PLATE	1
19	SL39096	SUPPORT	1
20	SL04316	SCREW	2



← Back 1 page

SK 24 AUTOMATIC SCRUBBER CODE: pl1455 ab SN from 01C000

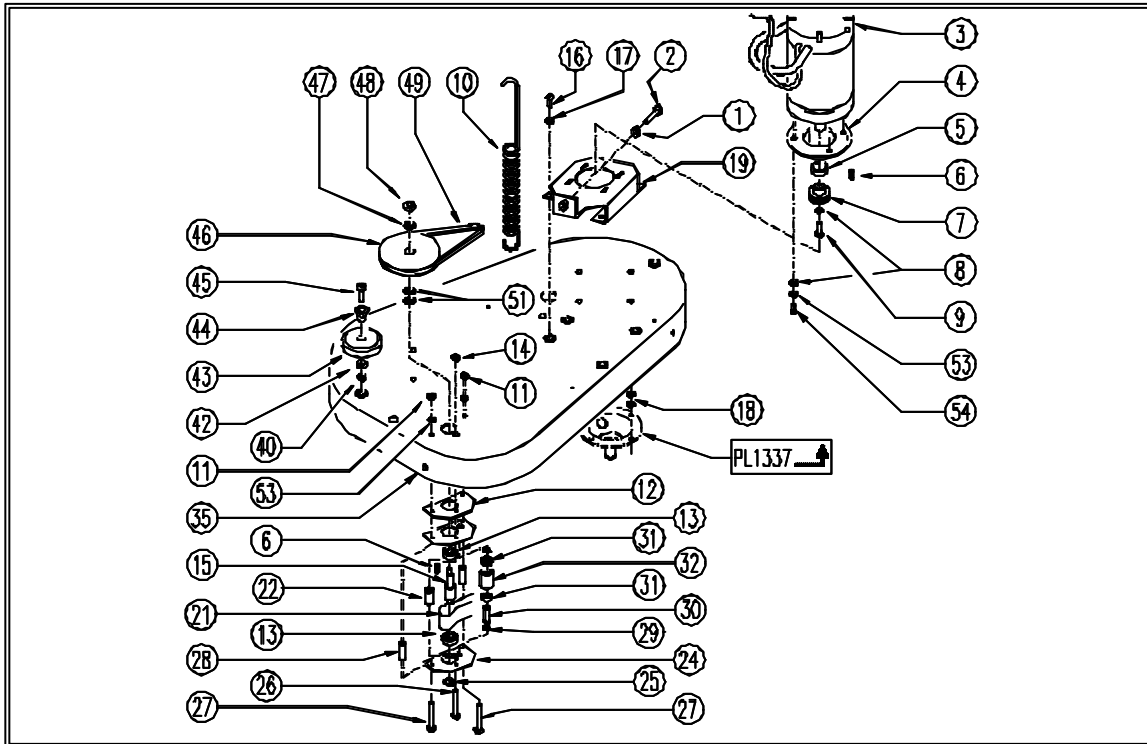

SK 24 AUTOMATIC SCRUBBER CODE: pl1455 ab SN from 01C000

REF.	CODE	DESCRIPTION	QTY
1	SL05004	NUT	1
2	SL04164	SCREW	1
3	SL02099	MOTOR	1
4	SL09648	FLANGE	1
5	SL07536	SPACER	1
6	SL11010	TANG / TONGUE	2
7	SL10049	PULLEY	1
8	SL06039	WASHER	5
9	SL04135	SCREW	1
10	SL13082	SPRING	1
11	SL05088	NUT	2
12	SL03541	GASKET	1
13	SL12029	BEARING	2
14	SL05017	NUT	1
15	SL07190	SHAFT	1
16	SL04039	SCREW	4
17	SL06093	WASHER	4
18	SL06022	WASHER	8
19	SL39127	SUPPORT	1
21	SL16042	BELT	1
22	SL07545	SPACER	1
24	SL39053	PLATE	2

Next page →



← Back 1 page

SK 24 AUTOMATIC SCRUBBER CODE: pl1455 ab SN from 01C000			
REF.	CODE	DESCRIPTION	QTY
25	SL11100	RING	1
26	SL04061	SCREW	1
27	SL04058	SCREW	2
28	SL07143	SPACER	2
29	SL11095	RING	2
30	SL11041	PIN / PLUG	1
31	SL12003	BEARING	2
32	SL10045	PULLEY	1
35	SL39121	HEAD	1
40	SL05048	SCREW	3
42	SL06025	WASHER	3
43	SL08040	WHEEL / SMALL WHEEL	3
44	SL07390	BUSHING / BUSH	3
45	SL04167	SCREW	3
46	SL10077	PULLEY	1
47	SL06087	WASHER	1
48	SL05039	NUT	1
49	SL16010	BELT	1
51	SL06058	WASHER	2
53	SL06023	WASHER	8
54	SL04002	SCREW	4



← Back 1 page

SK 24 AUTOMATIC SCRUBBER CODE: p11337 ac SN from 01K199

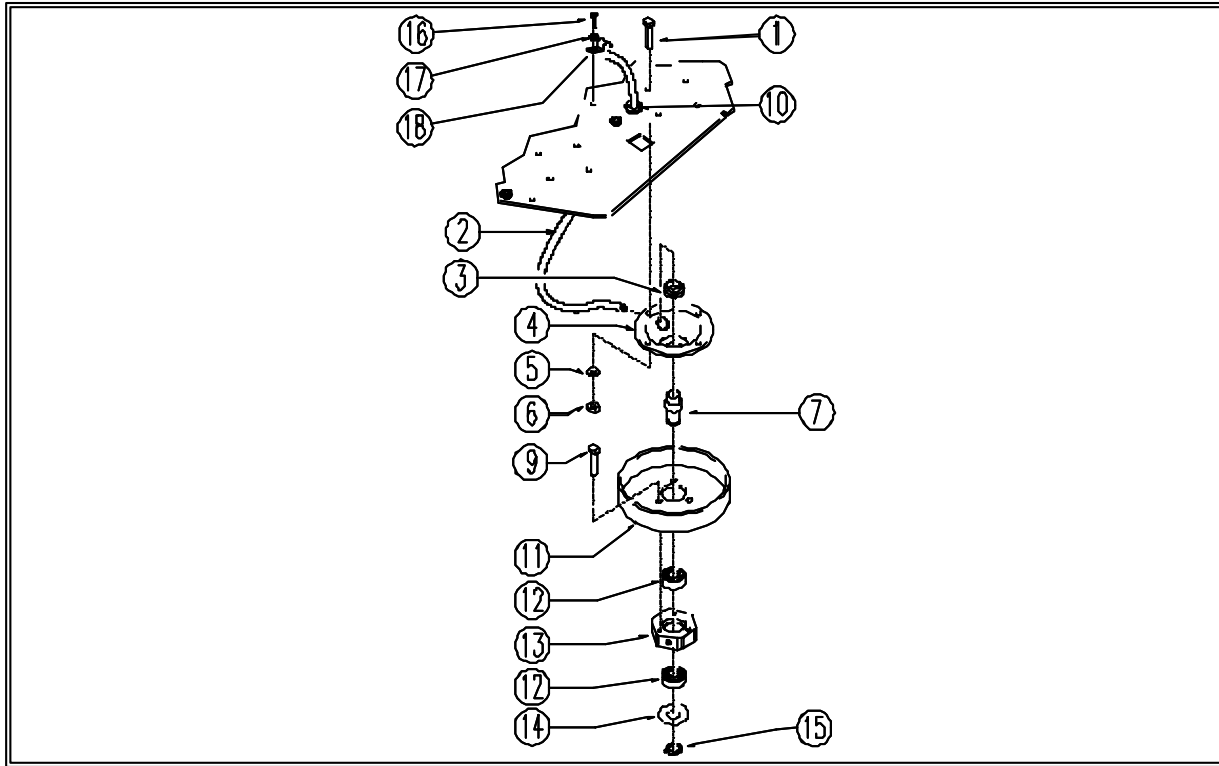

SK 24 AUTOMATIC SCRUBBER CODE: p11337 ac SN from 01K199

REF.	CODE	DESCRIPTION	QTY
1	SL04105	SCREW	8
2	SL19329	HOSE	2
3	SL05049	NUT	2
4	SL09920	FLANGE	2
5	SL06003	WASHER	8
6	SL05039	NUT	8
7	SL07535	PIN	2
9	SL04119	SCREW	6
10	SL23694	FAIRLEAD	2
11	SL10047	PULLEY	2
12	SL12025	BEARING	4
13	SL14175	HEXAGON	2
14	SL03247	GUARD	2
15	SL11096	SEEGER	2
16	SL04079	SCREW	2
17	SL06031	WASHER	2
18	SL23381	CLAMP	2



← Back 1 page

SK 24 AUTOMATIC SCRUBBER CODE: pl1456 ab SN from 01133

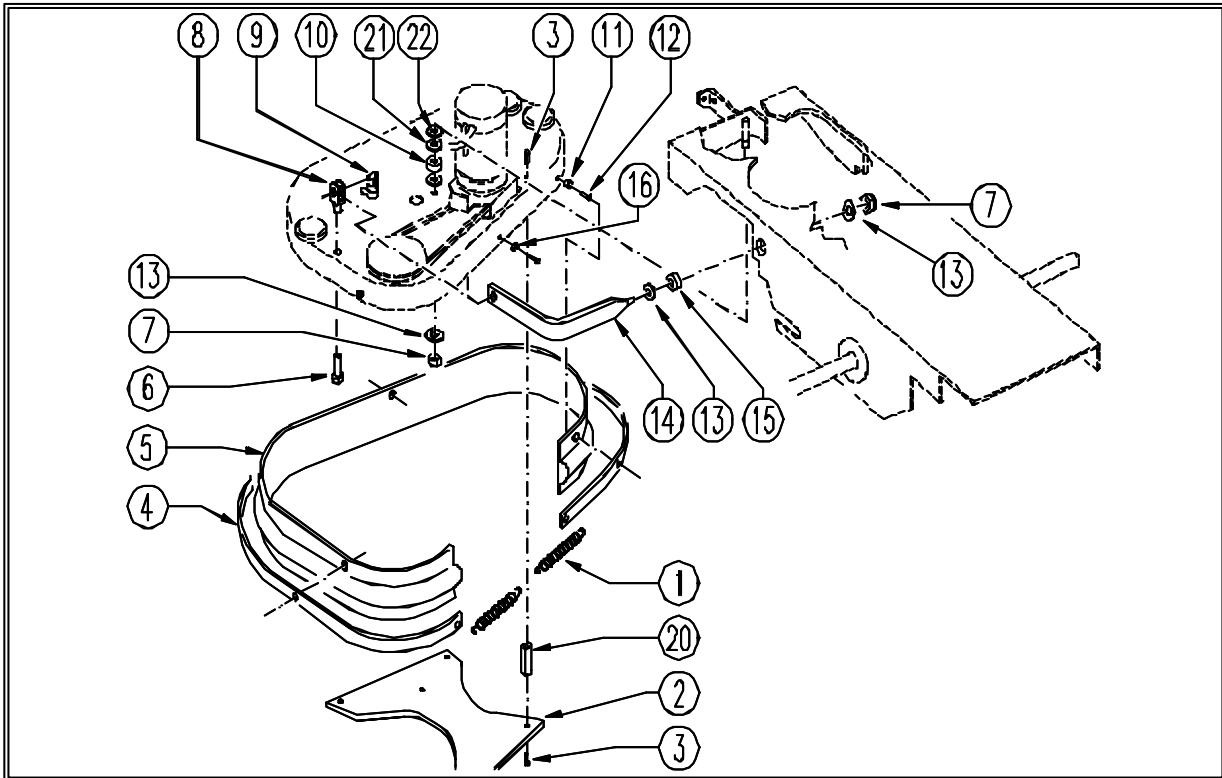

SK 24 AUTOMATIC SCRUBBER CODE: pl1456 ab SN from 01133

REF.	CODE	DESCRIPTION	QTY
1	SL13008	SPRING	2
2	SL03552	GUARD	1
3	SL04006	SCREW	10
4	SL03539	FLAP PRESS	1
5	SL03538	FLAP	1
6	SL04134	SCREW	1
7	SL05039	NUT	2
8	SL22008	FORK	1
9	SL22010	BRACKET / CLASP	1
16	SL05016	NUT	1
20	SL14355	SPACER	5
21	SL06062	WASHER	2
22	SL06101	WASHER	1
10	SL03209	RUBBER SHIM	1
11	SL07375	SPACER	3
12	SL04367	SCREW	4
13	SL06041	WASHER	3
14	SL39137	LEVER	1
15	SL07150	SPACER	1



Back 1 page

SK 24 AUTOMATIC SCRUBBER CODE: pl1341 ad SN from 01K198

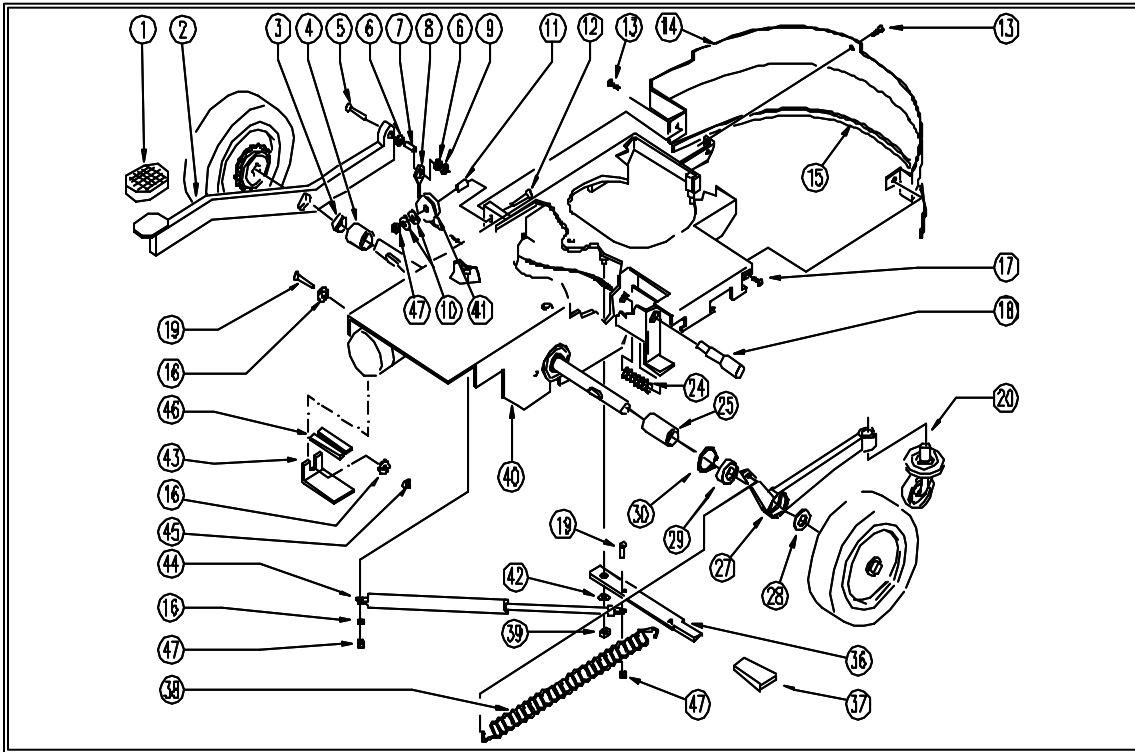

SK 24 AUTOMATIC SCRUBBER CODE: pl1341 ad SN from 01K198

REF.	CODE	DESCRIPTION	QTY
1	SL20009	RUBBER SHIM	1
2	SL39049	PEDAL	1
3	SL12071	BEARING	1
4	SL07519	SPACER	1
5	SL04036	SCREW	1
6	SL06034	WASHER	2
7	SL07561	SPACER	1
8	SL14346	CABLE	1
9	SL05087	NUT	1
10	SL06064	WASHER	2
11	SL07164	SPACER	1
12	SL04096	SCREW	1
13	SL04079	SCREW	2
14	SL39097	BULKHEAD	1
15	SL03542	OUTLINE	1
16	SL06022	WASHER	3
17	SL04065	SCREW	1
18	SL07516	PIN	1
19	SL04135	SCREW	2
20	SL08057	WHEEL	1
24	SL13128	SPRING	1
25	SL07520	SPACER	1

Next page



← Back 1 page

SK 24 AUTOMATIC SCRUBBER CODE: pl1341 ad SN from 01K198			
REF.	CODE	DESCRIPTION	QTY
27	SL39046	SUPPORT	1
28	SL06058	WASHER	2
29	SL12030	BEARING	1
30	SL11033	SEEGER	1
36	SL39048	LEVER	1
37	SL20054	HANDGRIP	1
38	SL13130	SPRING	1
39	SL05039	NUT	1
40	SL39050	FRAME	1
41	SL07094	PULLEY	1
42	SL06041	WASHER	1
43	SL09416	SUPPORT	1
44	SL13119	SPRING	1
45	SL05041	NUT	1
46	SL03571	SOFT GASKET	2
47	SL05058	NUT	3



← Back 1 page

SK 24 AUTOMATIC SCRUBBER CODE: pl1343 aa SN from 00G056

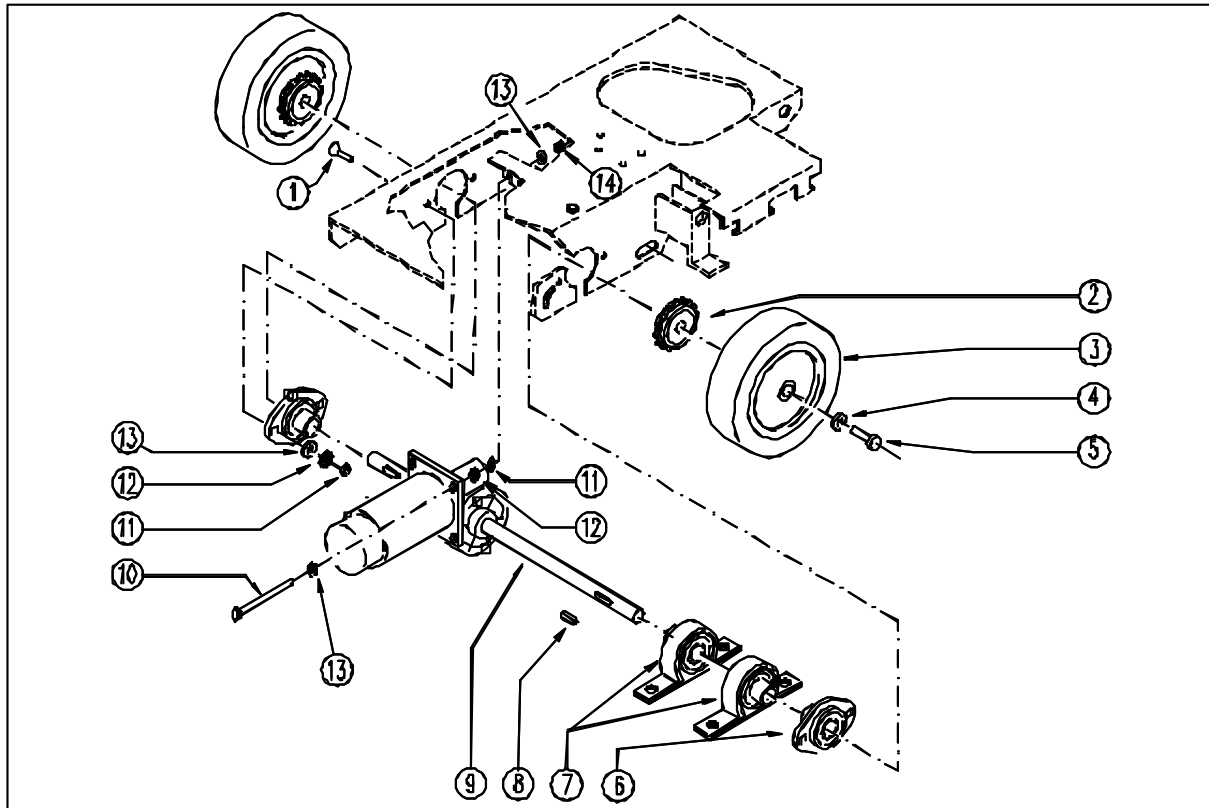

SK 24 AUTOMATIC SCRUBBER CODE: pl1343 aa SN from 00G056

REF.	CODE	DESCRIPTION	QTY
1	SL04339	SCREW	4
2	GR12011	BEARING	2
3	SL08033	WHEEL	2
4	SL06025	WASHER	2
5	SL04077	SCREW	2
6	SL12022	FLANGE	2
7	SL12070	SUPPORT	2
8	SL11034	TANG / TONGUE	2
9	SL02202	MOTOR - SHAFT	1
10	SL04194	SCREW	1
11	SL05017	NUT	5
12	SL06023	WASHER	5
13	SL06022	WASHER	7
14	SL05041	NUT	1



← Back 1 page

SK 24 AUTOMATIC SCRUBBER CODE: pl1010 ae SN from 01J899

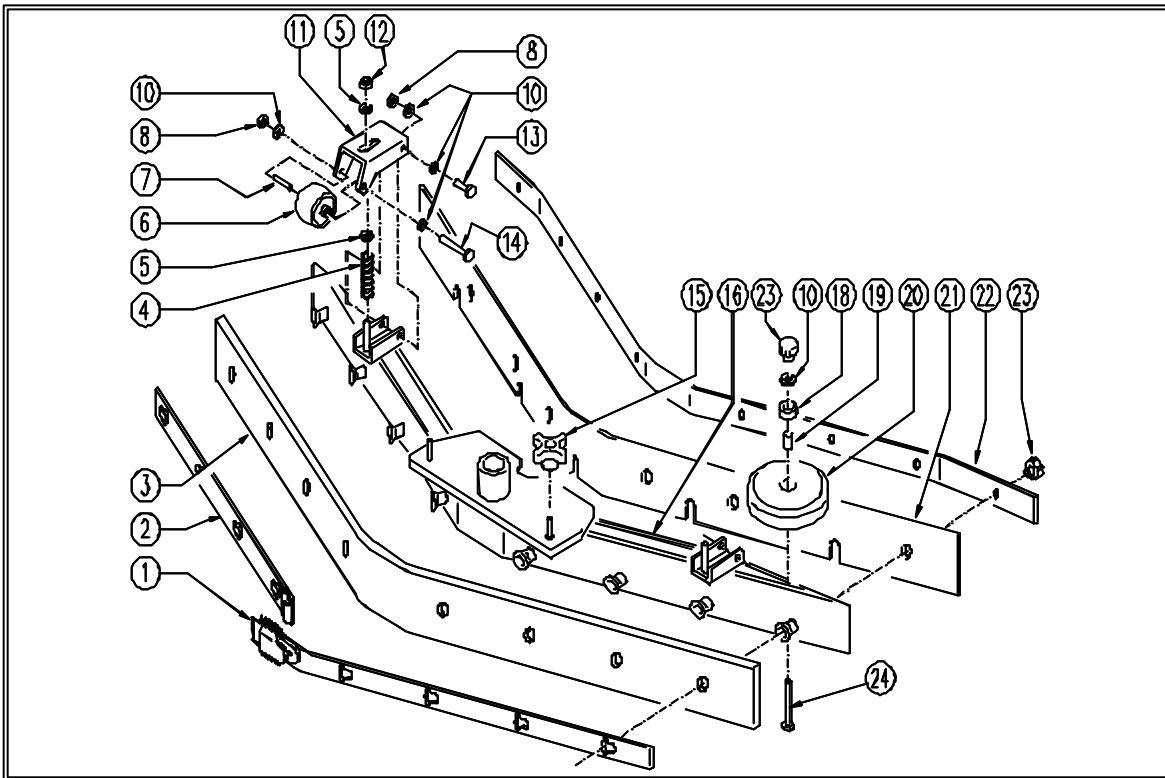

SK 24 AUTOMATIC SCRUBBER CODE: pl1010 ae SN from 01J899

REF	CODE	DESCRIPTION	QTY
	GR39027	SQUEEGEE UNIT	
1	SL39029	BLADE HOLDER	1
2	SL39030	BLADE HOLDER	1
3	SL03518	BLADE	1
4	SL13103	SPRING	2
5	SL06041	WASHER	4
6	SL08058	WHEEL	2
7	SL07526	SPACER	2
8	SL05058	NUT	6
10	SL06022	WASHER	14
11	SL39033	SUPPORT	2
12	SL05039	NUT	2
13	SL04135	SCREW	4
14	SL04061	SCREW	2
15	SL20061	HANDLE	2
16	SL39136	BODY	1
18	SL17608	BUSHING/BUSH	2
19	SL07065	SPACER	2
20	SL08040	WHEEL	2
21	SL03517	BLADE	1
22	SL39028	BLADE HOLDER	1
23	SL20058	HANDLE	10
24	SL04058	SCREW	2



← Back 1 page

SK 24 AUTOMATIC SCRUBBER CODE: pl1345 ac SN from 01G000

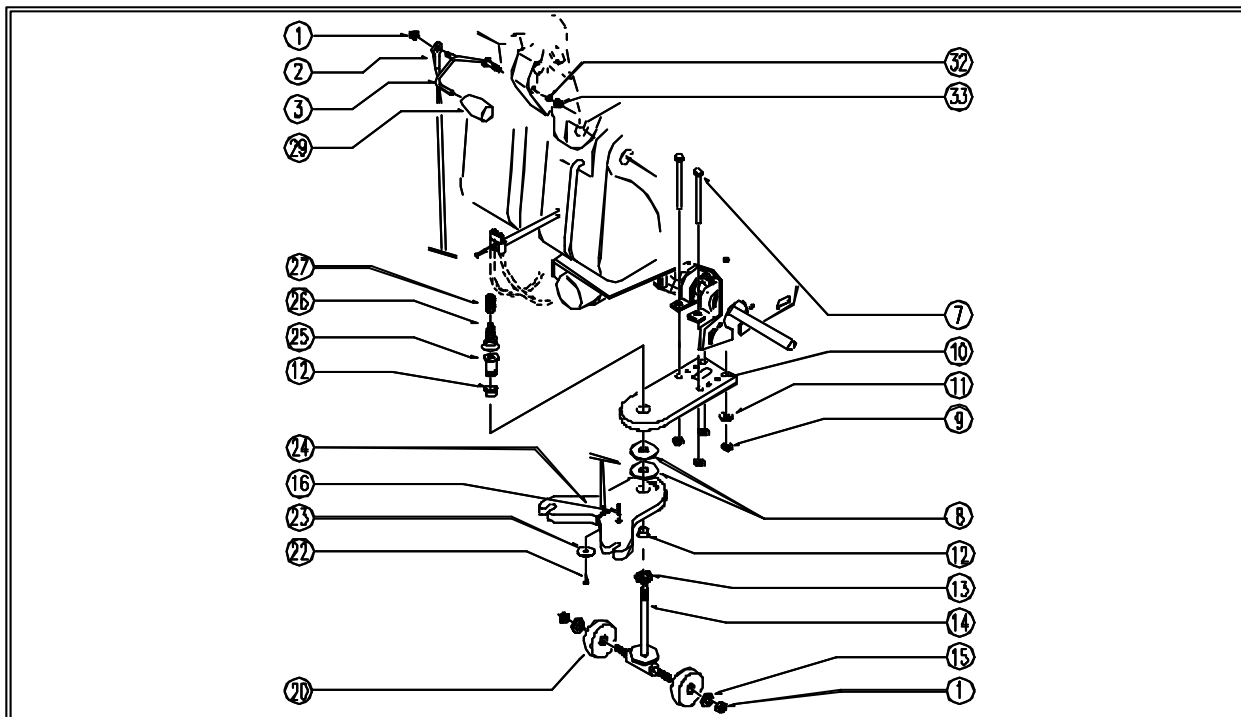

SK 24 AUTOMATIC SCRUBBER CODE: pl1345 ac SN from 01G000

REF.	CODE	DESCRIPTION	QTY
1	SL05039	NUT	3
2	SL14247	CABLE	1
3	SL39036	LEVER	1
7	SL04004	SCREW	5
8	SL06106	WASHER	2
9	SL05039	NUT	5
10	SL39032	SUPPORT	1
11	SL06003	WASHER	4
12	SL12035	BEARING	2
13	SL05086	NUT	1
14	SL07507	PIN	1
15	SL06041	WASHER	2
16	SL11126	GRAIN	1
20	SL08043	WHEEL / SMALL WHEEL	2
22	SL04319	SCREW	1
23	SL06084	WASHER	1
24	SL39031	PLATE	1
25	SL07509	PIN	1
26	SL13126	SPRING	1
27	SL07508	NUT	1
29	SL20007	HANDGRIP	1
32	SL06050	WASHER	1
33	SL05032	NUT	1



← Back 1 page

SK 24 AUTOMATIC SCRUBBER CODE: pl1346 ae SN from 02A200

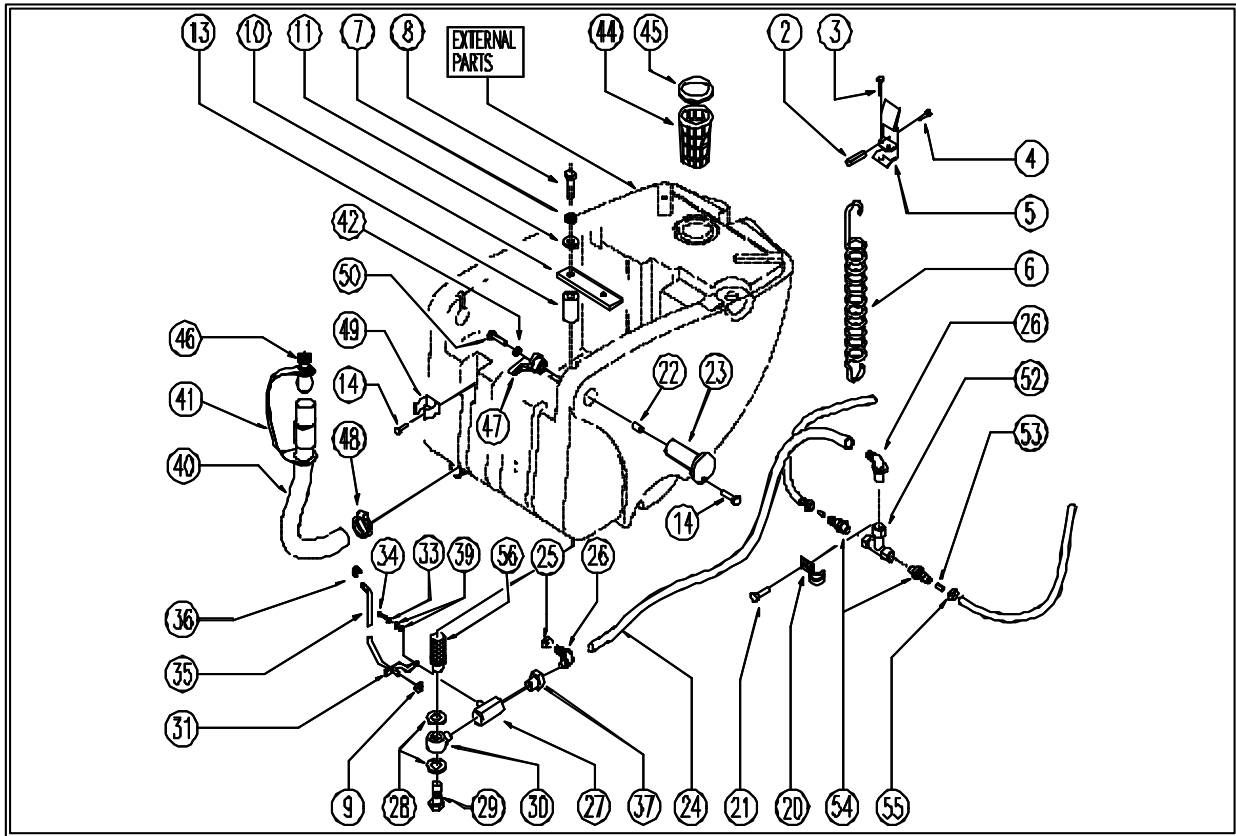

SK 24 AUTOMATIC SCRUBBER CODE: pl1346 ae SN from 02A200

REF.	CODE	DESCRIPTION	QTY
2	SL07425	SPACER	1
3	SL04222	SCREW	2
4	SL04278	SCREW	1
5	SL09829-4	HOOK	1
6	SL13102	SPRING	1
7	SL06002	WASHER	2
8	SL04143	SCREW	2
9	SL05041	NUT	3
10	SL39098	BRACKET	1
11	SL06003	WASHER	2
13	SL07512	SPACER	2
14	SL04371	SCREW	4
20	SL23381	CLAMP	1
21	SL04062	SCREW	1
22	SL04171	INSERT	2
23	SL17493-1	PIN	2
24	SL19312	HOSE	1
25	SL14007	CLAMP	1
26	SL18341	UNION / CONNECTOR	2
27	SL18407	TAP	1

Next page →



← Back 1 page

SK 24 AUTOMATIC SCRUBBER CODE: pl1346 ae SN from 02A200			
REF.	CODE	DESCRIPTION	QTY
28	SL03536	WASHER	2
29	SL18257-L	SCREW	1
30	SL18256	ARTICULATION	1
31	SL39171	LEVER	1
33	SL06031	WASHER	1
34	SL04341	SCREW	1
35	SL39091	ROD	1
36	SL11113	SEEGER	1
37	SL18109	REDUCTION	1
39	SL06041	WASHER	2
40	SL19113-1	HOSE	1
41	SL03577	CLAMP	1
42	SL06015	WASHER	3
44	SL03526	FILTER	1
45	SL03543	GASKET	1
46	SL18395	KNOB	1
47	SL17491-1	LEVER	1
48	SL14063	CLAMP	1
49	SL13118	DUCT LOCK	1
50	SL04135	SCREW	2
52	SL18193	UNION / CONNECTOR	1
53	SL04170	INSERT	2
54	SL18150	UNION / CONNECTOR	2
55	SL14109	CLAMP	2
56	SL18405	FILTER	1



← Back 1 page

SK 24 AUTOMATIC SCRUBBER CODE: pl1457 aa SN from 01B600

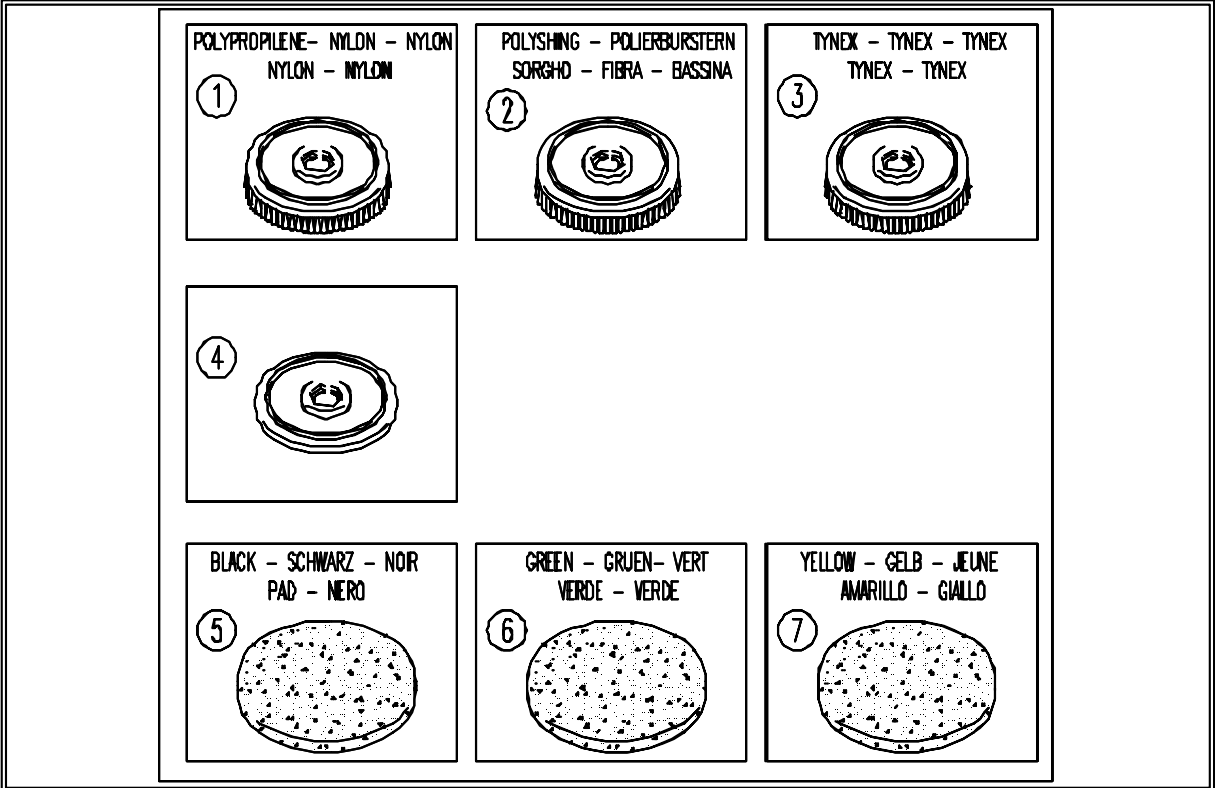

REF.	CODE	DESCRIPTION	QTY
1	AL02450	POLYPROPYLENE BRUSH	
2	AL02451	POLYSHING BRUSH	
3	AL02452	TYNEX BRUSHES	
4	AL02453	PAD DRIVER	
5	AL03310	STRIPPING PAD (BLACK)	
6	AL03316	STRIPPING PAD (GREEN)	
7	AL03317	STRIPPING PAD (YELLOW)	



← Back 1 page

SK 24 AUTOMATIC SCRUBBER CODE: pl1339N ad SN from 02A000

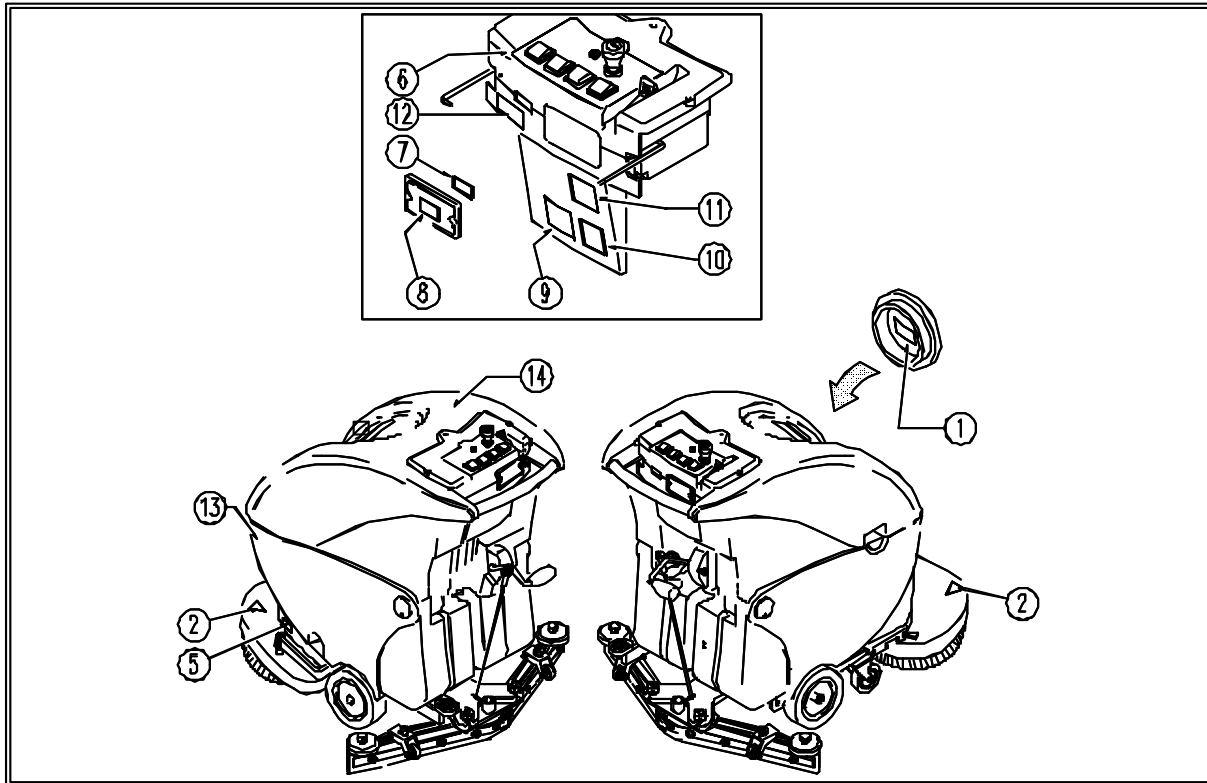

REF.	CODE	DESCRIPTION	QTY
1	SL25056	LABEL	1
2	SL25364	LABEL	2
5	SL25369	LABEL	1
6	SL25960	LABEL	1
7	SL25928	LABEL	1
8	SL25187	LABEL	1
9	SL25002	LABEL	1
10	SL25177	LABEL	1
11	SL25053	LABEL	1
12	SL25401-3	PART NUMBER	1
13	SL17594	BLACK TANK	1
13	SL17594GR	GREY TANK	1
13	SL17594IC	BLUE TANK	1
14	SL17595AS	GREY TANK	1
14	SL17595BC	RED TANK	1
14	SL17595IC	BLUE TANK	1



← Back 1 page

SK 24 AUTOMATIC SCRUBBER CODE: pl1458N aa SN from 01E635

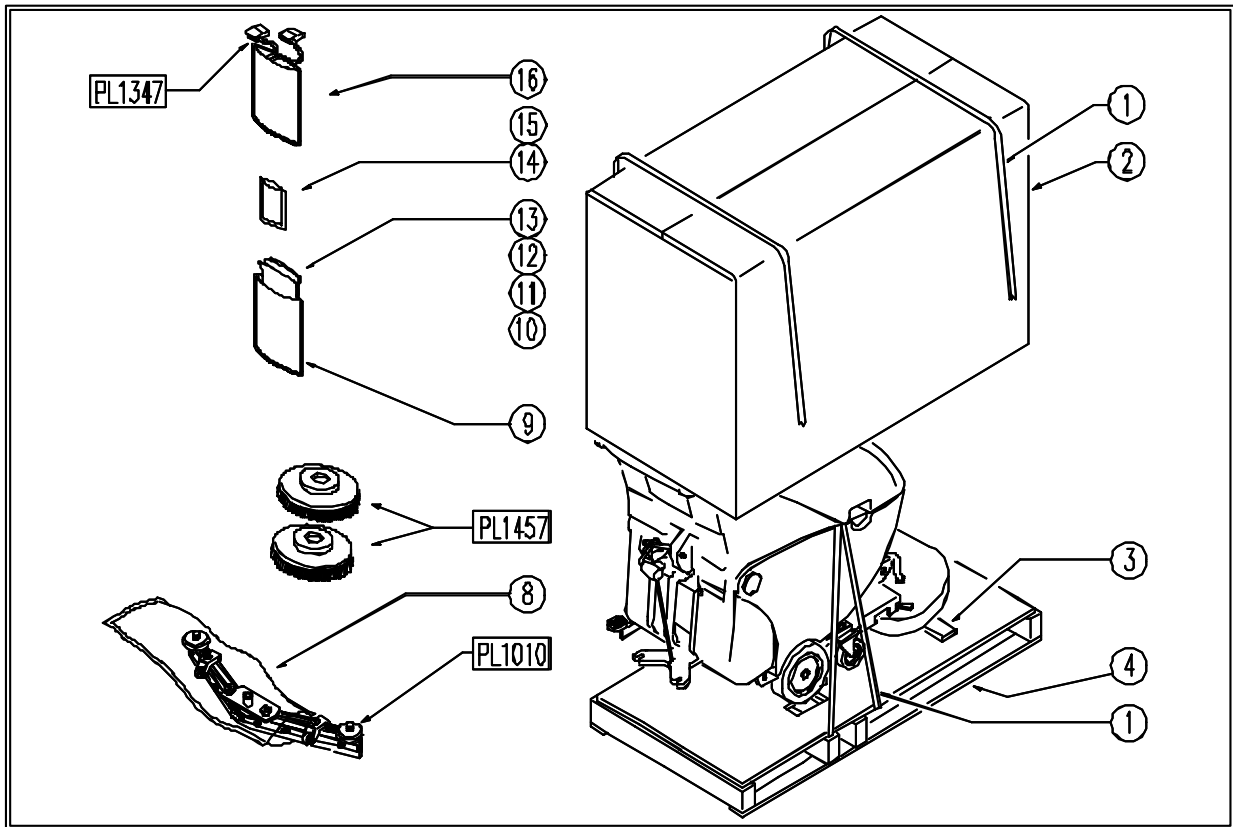

REF.	CODE	DESCRIPTION	QTY
1	MP14300	STRAP	/
2	SL26133	CARDBOARD	1
3	SL26011	REINFORCEMENT	1
4	SL26132	PALLET	1
8	MP14302	ENVELOPE	1
9	SL25374N	ENVELOPE	1
10	SL25303N	SHEET	1
11	SL25401-3	WARRANTY COUPON	1
12	SL25401-8	EC CERTIFICATION	1
13	SL25989N-4	MANUAL	1
14	SL26029	ENVELOPE	1
15	SL23010K	CONNECTOR	1
16	SL26017	ENVELOPE	1



← Back 1 page

SK 24 AUTOMATIC SCRUBBER CODE: wd27193 ac SN from 02A000

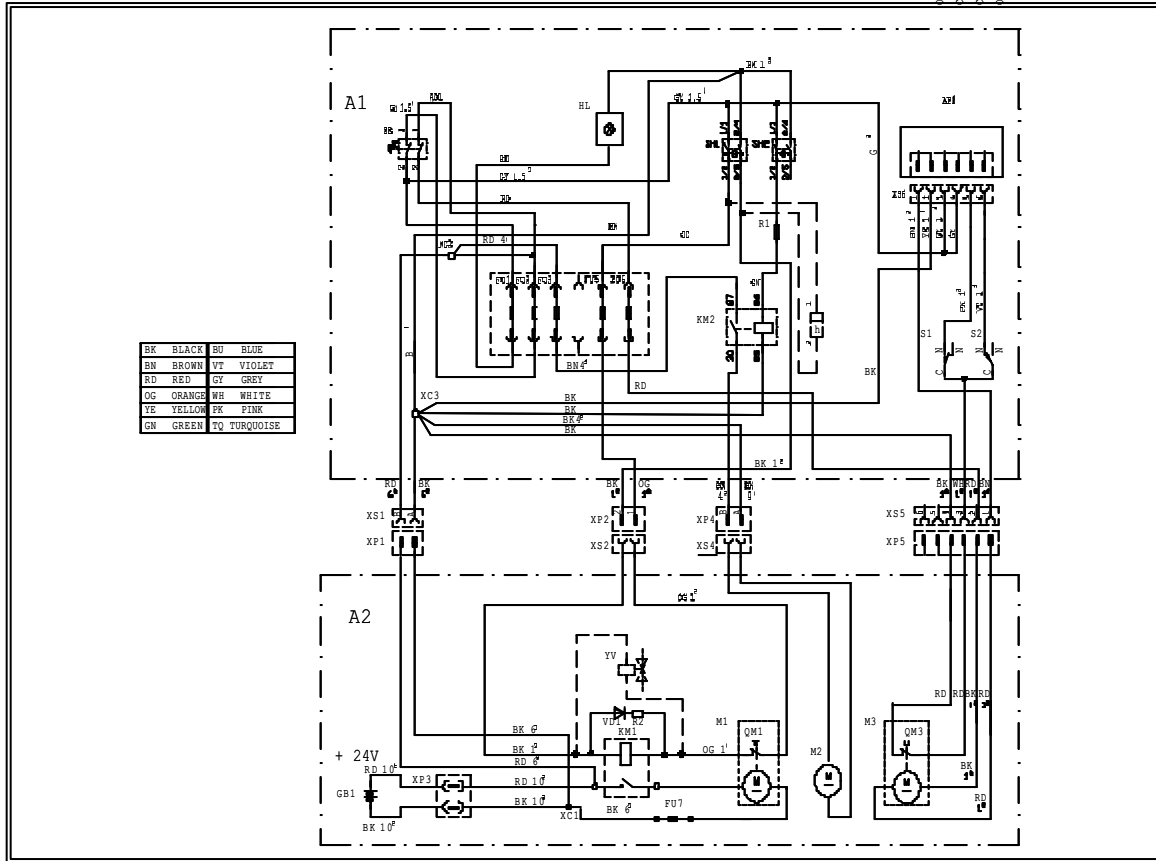

SK 24 AUTOMATIC SCRUBBER CODE: wd27193 ac SN from 02A000

REF.	CODE	DESCRIPTION	QTY
AP1	SL23731-2	GEARCASE / BOARD	
FU1	SL23144	FUSIBLE	
FU2	SL23148	FUSIBLE	
FU3	SL23148	FUSIBLE	
FU5	SL23144	FUSIBLE	
FU6	SL23148	FUSIBLE	
FU7	SL23696	FUSIBLE	
GB1		BATERÍA	
HL	SL23031	INDICADOR	
KM1	SL23001	TELERRUPTOR	
KM2	SL23719	RELAY	
M1	SL02099	MOTOR	
M2	SL02303-J	MOTOR	
M3	SL02202	MOTOR	
QM1		THERMAL PROTECTION	
QM3		THERMAL PROTECTION	
R1	SL23734	RESISTANCE	
R2	SL23899	RESISTANCE	
S1	SL23109	MICROSWITCH	

Next page →



← Back 1 page

SK 24 AUTOMATIC SCRUBBER CODE: wd27193 ac SN from 02A000			
REF.	CODE	DESCRIPTION	QTY
S2	SL23109	MICROSWITCH	
SB		PUSH-BUTTON	
SH1	SL23183	INTERRUPTOR	
SH2	SL23183	INTERRUPTOR	
VD1	SL23470	DIODE	
XC1	SL23103	INSULATOR	
XC2	SL23414	CLAMP	
XC3	SL23414	CLAMP	
XP1	SL23562	CONECTOR	
XP2	SL23550	CONECTOR	
XP3	SL23010K	CONECTOR	
XP4	SL23562	CONECTOR	
XP5	SL23558	CONECTOR	
XS1	SL23564	CONECTOR	
XS2	SL23551	CONECTOR	
XS4	SL23564	CONECTOR	
XS5	SL23559	CONECTOR	
XS6	SL23902	CONECTOR	
h	SL23984J	HOUR METER (OPTIONAL)	
YV	SL18404	ELECTROVALVE (OPTIONAL)	
A1		CONTROL PANEL	
A2		BODY WIRING DIAGRAM	



Back 1 page

SK 24 AUTOMATIC SCRUBBER CODE: wd27193-1 ac SN from 02A000

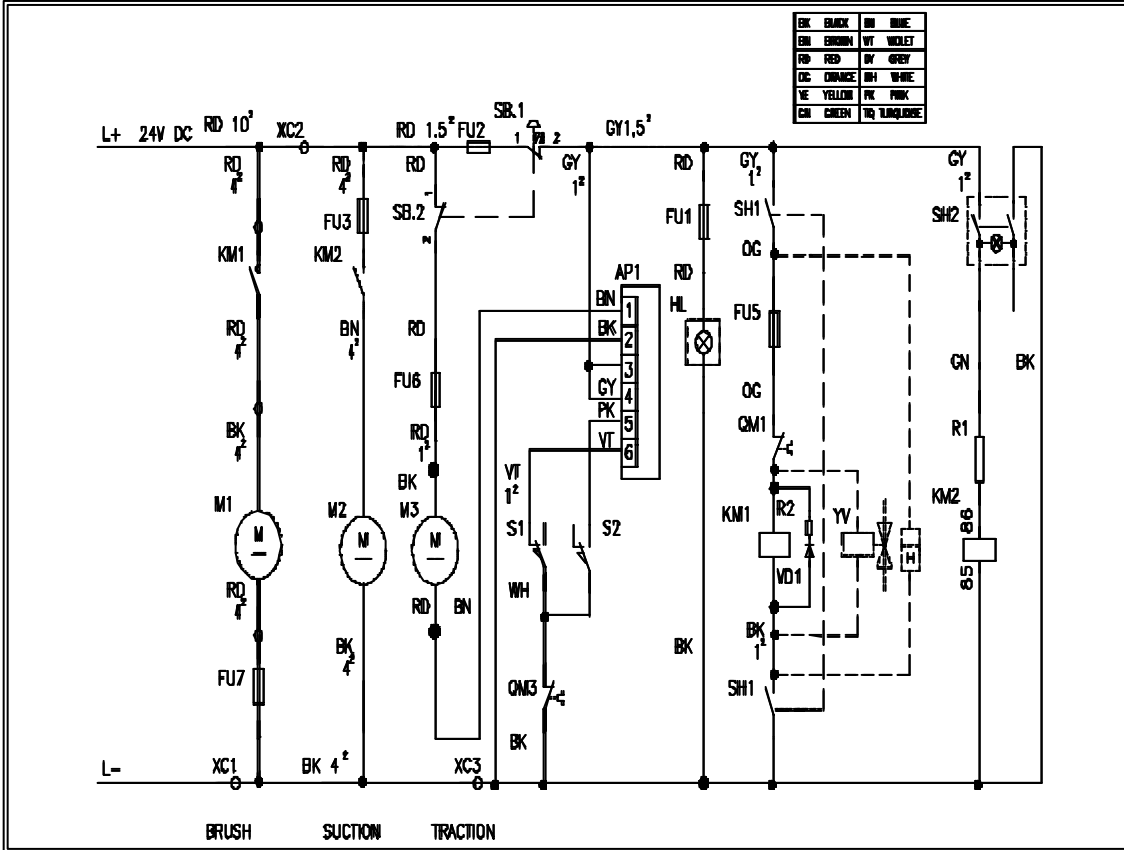

SK 24 AUTOMATIC SCRUBBER CODE: wd27193-1 ac SN from 02A000

REF.	CODE	DESCRIPTION	QTY
AP1	SL23731-2	GEARCASE / BOARD	
FU1	SL23144	FUSIBLE	
FU2	SL23148	FUSIBLE	
FU3	SL23148	FUSIBLE	
FU5	SL23144	FUSIBLE	
FU6	SL23148	FUSIBLE	
FU7	SL23696	FUSIBLE	
GB1		BATERÍA	
HL	SL23031	INDICADOR	
KM1	SL23001	TELERRUPTOR	
KM2	SL23719	RELAY	
M1	SL02099	MOTOR	
M2	SL02303-J	MOTOR	
M3	SL02202	MOTOR	
QM1		THERMAL PROTECTION	
QM3		THERMAL PROTECTION	
R1	SL23734	RESISTANCE	
R2	SL23899	RESISTANCE	
S1	SL23109	MICROSWITCH	

Next page



← Back 1 page

SK 24 AUTOMATIC SCRUBBER CODE: wd27193-1 ac SN from 02A000

REF.	CODE	DESCRIPTION	QTY
S2	SL23109	MICROSWITCH	
SB		PUSH-BUTTON	
SH1	SL23183	INTERRUPTOR	
SH2	SL23183	INTERRUPTOR	
VD1	SL23470	DIODE	
XC1	SL23103	INSULATOR	
XC2	SL23414	CLAMP	
XC3	SL23414	CLAMP	
h	SL23984J	HOUR METER (OPTIONAL)	
YV	SL18404	ELECTROVALVE (OPTIONAL)	
A1		CONTROL PANEL	
A2		BODY WIRING DIAGRAM	



Eagle Power™ Products Group

Warranty Policy

Limited Warranty

Eagle Power Products (EPP) warrants new cleaning equipment against defects in material and workmanship under normal use and service to the original purchaser as detailed below.

10 Years

Subject to the conditions stated below, EPP warrants polyethylene tanks and housings to be free from defects in materials and workmanship for a period of ten years.

3 Years

Subject to the conditions stated below, EPP warrants all automatic scrubber components to be free from defects in materials and workmanship for a 3-year period. Parts replaced or repaired are warranted for the remainder of the original warranty period.

1 Year

Subject to the conditions stated below, EPP warrants all other cleaning equipment components to be free from defects in materials and workmanship for a 1-year period. Parts replaced or repaired are warranted for the remainder of the original warranty period. Batteries are prorated for one year.

EPP will furnish and charge for replacement parts, including transportation, to the original owner through an EPP authorized service center. If the part is returned within 30 days and is found defective, the owner will be credited for the cost of the replacement part including shipping and handling.

Labor charges are covered for one year from the date of purchase if provided by an authorized EPP service center. Travel is covered for 90 days for battery operated equipment only.

Wear items exempt from warranty include belts, carbon brushes, power cords, wheels, pad drivers, clutch plates, brushes, pads, handle grips, filters, screens, throttle cables, and squeegees.

This warranty shall not apply to failures caused by misuse or abuse, improper maintenance as stated in the operation manuals, use of unauthorized repair parts, repairs by other than an EPP authorized service center, and damage in transit.

EPP disclaims and denies any liability for any direct, indirect, special incidental or consequential damage which may be suffered as a result of sale, delivery, servicing, use, loss of any product, downtime, labor, freight, or other charges not expressly included herein.

Date Purchased: _____

Serial Number: _____

Serial Number: _____

Please be sure to record this information. This information will be necessary for future warranty claims.



1174 Northland Drive Mendota Heights, MN 55120
651.686.5399 Fax 651.686.5695
www.eaglepower.com

Eagle Power Products Sales and Service Provided by: