



Electronic Service Manuals

This electronic document is provided as a service to our customers. We do not create the contents of the information contained in this document. Should you have detailed questions pertaining to the information contained in this document, you may contact Michco, or the manufacturer which provided the original information in this electronic deliverable. Michco's only part in this electronic deliverable was the electronic assembly process. By providing this manual on line we are not guaranteeing parts availability.

You may contact Michco through the following methods:

Phone (517) 484-9312 or (800) 331-3339

2011 N. High St. -- Lansing, Michigan -- 48906

Fax: (517) 484-9836

Email: CustServe@Michco.com

Web site: www.Michco.Com

Parts Web site: www.FloorMachineParts.Com

Order Parts on Line at:

www.FloorMachineParts.Com

Directly to Parts & Service:

By Email: **Shop@Michco.com**

By Fax: (517) 702-2041

By Voice: Use numbers above.

Serving the Cleaning Industry Since 1922

Notice: All copyrighted material remains property of original owners, all trademarks are property of respective owners. Manuals are subject to Manufacturer's reproduction limitations. Originals or reproductions were provided by manufacturers through a request. We make no warranty as to the correctness of information provided in this document and you assume all risk. By placing these manuals on line we are not declaring our corporation to be an manufacturer authorized dealer or provider, please check our web site for authorized manufacturers we represent.

Eagle Power™

Products Group



PANTHER 28

28" AUTOMATIC

SCRUBBER

ENTER 

PARTS MANUAL



Click on icon to return to this page.

← Back 1 page

PANTHER 28 CODE: PF02380NTG-1 ab SN from 01J860

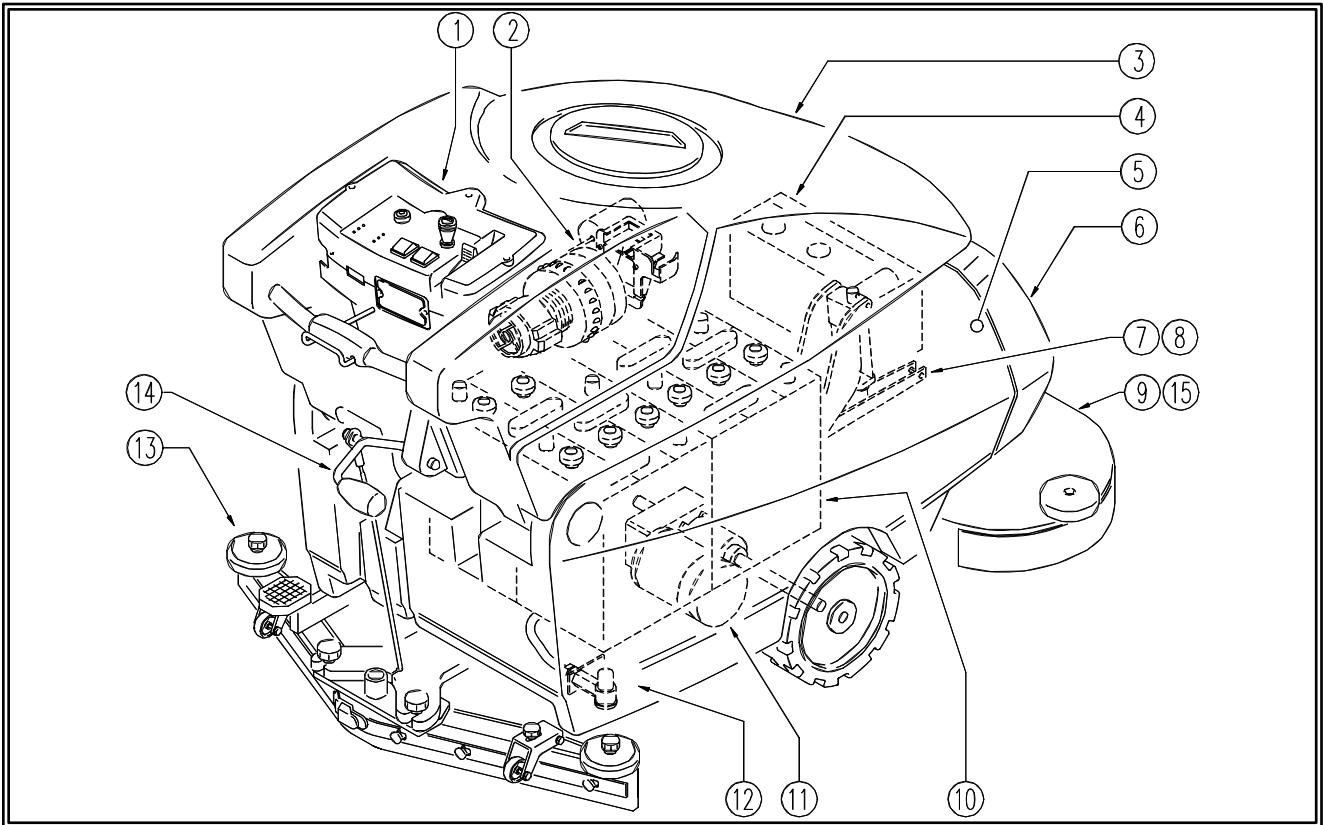

REF.	CODE	DESCRIPTION
1	PL1420	CONTROL PANEL
2	PL1421	ASPIRATOR
3	PL1422	TANK
4	PL1431	ELECTRIC UNIT
5	PL1423	TANK
6	PL1433N	EXTERNAL PARTS
7	PL1428	HEAD LIFT-1
8	PL1429	HEAD LIFT-2
9	PL1425	HEAD 70
10	PL1432	BATTERY
11	PL1424	DRIVE - BRAKE
12	PL1427	HYDRAULIC UNIT
13	PL1452	SQUEEGEE
14	PL1430	SQUEEGEE LIFT
15	PL1434	BRUSHES
	EPF02380N-1	LABELS - DOCUMENTS
	IPF02380-1	PACKING
	WD27195	WIRING DIAGRAM
	WD27195-1	ELEC. SCHEMATIC DIAGRAM



← Back 1 page

PANTHER 28 CODE: pl1420 ac SN from 01C687

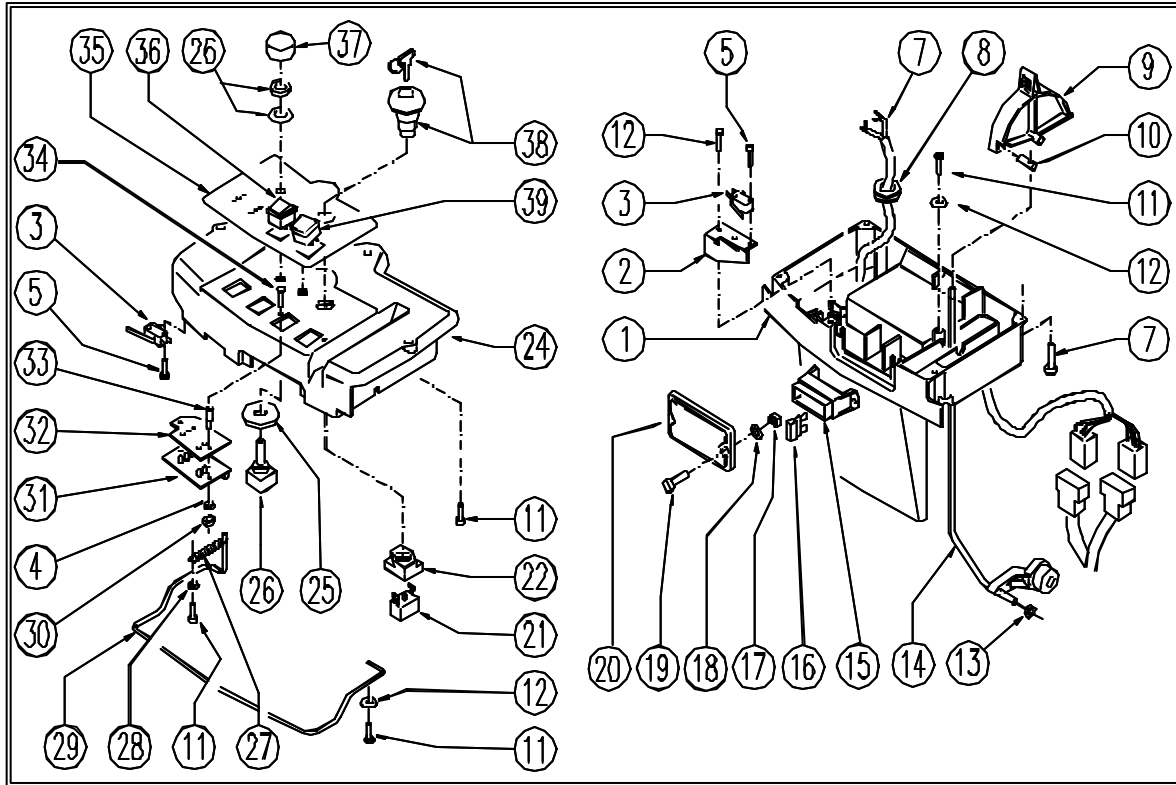

PANTHER 28 CODE: PL1420

REF.	CODE	DESCRIPTION	QTY
	GR23741	PREASSEMBLED CTRL PANEL	1
1	SL17489-1L	CONTROL PANEL	1
2	SL39083	SPRING	1
3	SL23718	MICROSWITCH	3
4	SL06056	WASHER	2
5	SL04214	SCREW	6
6	SL04187	SCREW	6
7	SL23741	WIRING	1
8	SL23695	FAIRLEAD	1
9	SL17490-1	LEVER	1
10	SL09808	ARTICULATION	1
11	SL04327	SCREW	4
12	SL06014	WASHER	2
14	SL39114	ROD	1
13	SL05058	NUT	1
15	SL23894-1	FUSE HOLDER	1
16	SL23144	FUSE	3
17	SL05077	NUT	2
18	SL03116	GASKET	4
19	SL04377	SCREW	2

Next page →



← Back 1 page

PANTHER 28 CODE: PL1420			
REF.	CODE	DESCRIPTION	QTY
20	SL17149-1	LID	1
21	SL23956	CONNECTION	1
22	SL23955	BASE	1
24	SL17488-1L	CONTROL PANEL	1
25	SL06011	WASHER	2
26	SL23872	POTENTIOMETER	1
27	SL13090	SPRING	1
28	SL06019	WASHER	1
29	SL39059	LEVER	1
30	SL05019	NUT	2
31	SL23738	BOARD	1
32	SL03554	PLAQUE	1
33	SL07534	SPACER	2
34	SL04384	SCREW	2
35	SL25887	CONTROL PANEL STICKER	1
36	SL23649	SWITCH	1
37	SL23821	HANDGRIP	1
38	SL23954	OPERATOR	1
39	SL23708	PUSH-BUTTON	1



← Back 1 page

PANTHER 28 CODE: pl1421 ab SN from 01G000

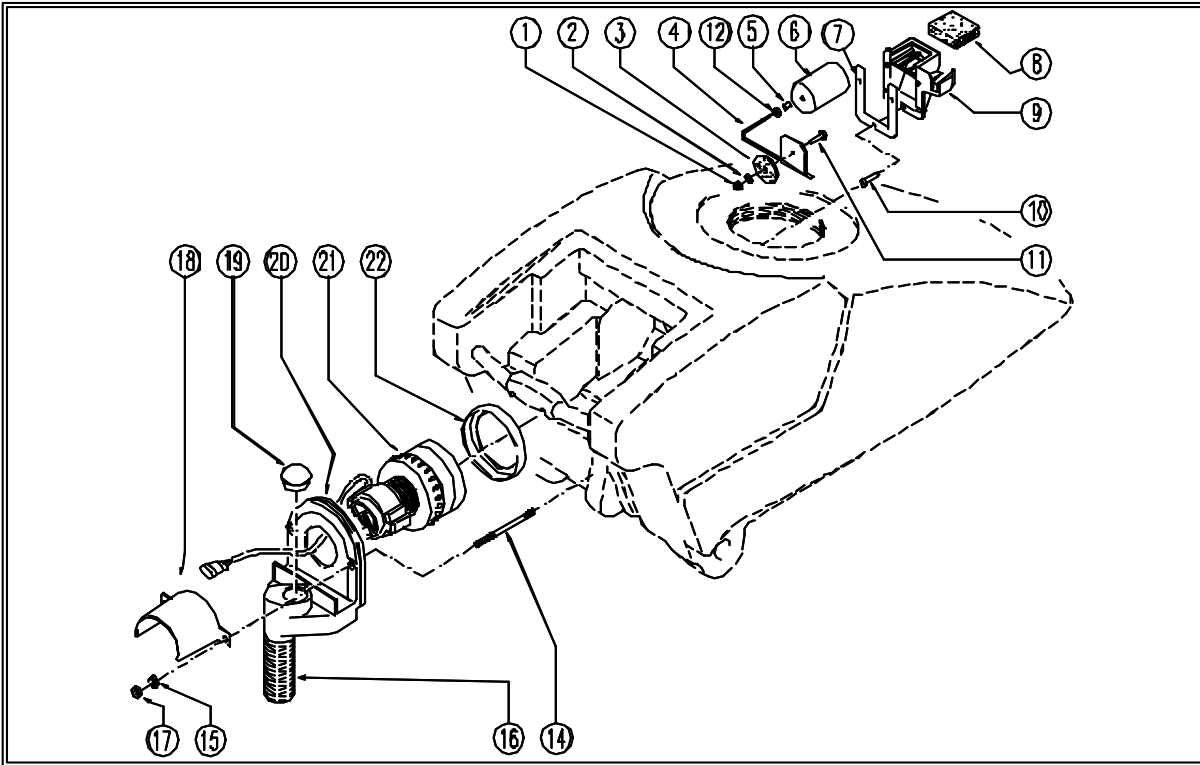

REF.	CODE	DESCRIPTION	QTY
1	SL05087	NUT	1
2	SL06038	WASHER	1
3	SL03346	GASKET	1
4	SL09827	ROD	1
5	SL04388	INSERT	1
6	SL18393	FLOAT	1
7	SL03429	GASKET	1
8	SL03345	FILTER	1
9	SL17492-1	SUPPORT	1
10	SL04095	SCREW	3
11	SL04310	SCREW	1
12	SL05017	NUT	1
14	SL04276	SCREW	2
15	SL06022	WASHER	2
16	SL19335	PIPE	1
17	SL05041	NUT	2
18	SL03514	SUCTION CONVEYOR	1
19	SL14240	CAP	1
20	SL03297	CAP / SHELL	1
21	SL02303-J	EXHAUSTER / ASPIRATOR	1
22	SL03159	GASKET	1



← Back 1 page

PANTHER 28 CODE: pl1422 ad SN from 01H38

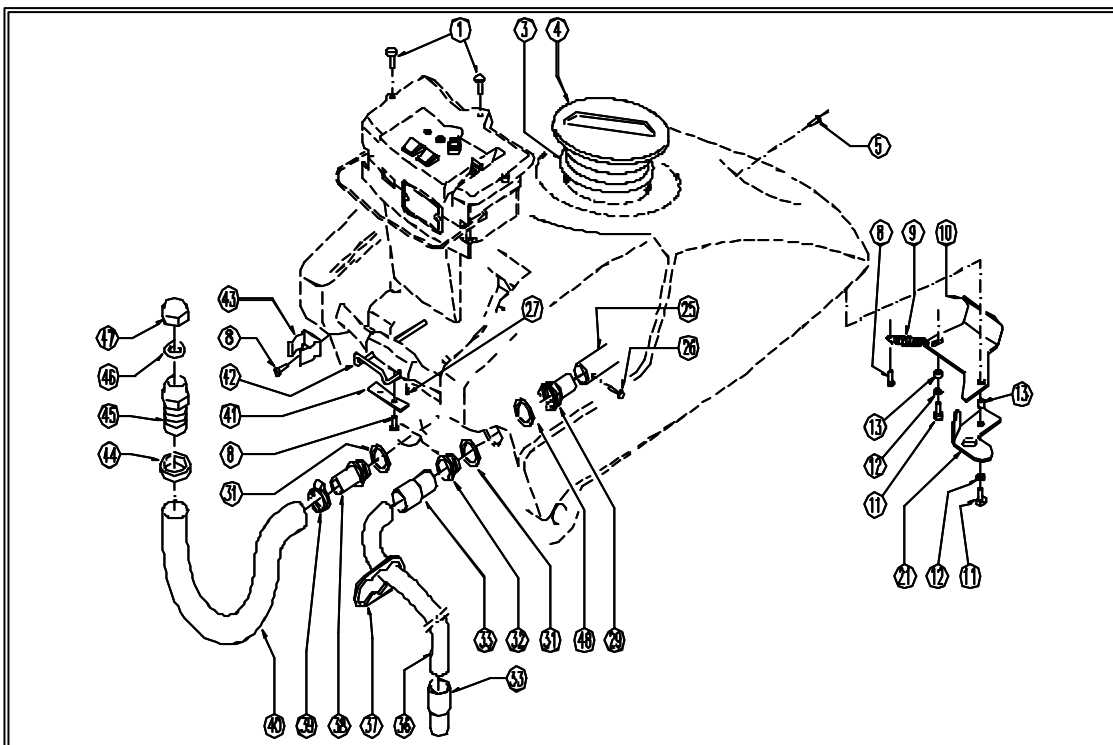

PANTHER 28 CODE: pl1422 ad SN from 01H38

REF.	CODE	DESCRIPTION	QTY
1	SL04377	SCREW	3
3	SL03487	GASKET	1
4	SL17468	LID	1
5	SL04311	SCREW	2
8	SL04371	SCREW	5
9	SL13090	SPRING	1
10	SL39069	HOOKING / COUPLING	1
11	SL04269	SCREW	2
12	SL06041	WASHER	2
13	SL07150	BUSHING / BUSH	2
21	SL39109	PLAQUE	1
25	SL07547	PIPE	1
26	SL04325	SCREW	1
27	SL04319	SCREW	1
29	SL18349	UNION/CONNECTOR	1
31	SL03416	GASKET	2
32	SL18355	SUCTION OPENING	1
33	SL14003	SLEEVE	2
36	SL19021	HOSE	1
37	SL03437	PLAQUE	1
38	SL18362	HOSE HOLDER	1
39	SL14354	CLAMP	1

Next page →



← Back 1 page

PANTHER 28 CODE: pl1422 ad SN from 01H38			
REF.	CODE	DESCRIPTION	QTY
40	SL19089	HOSE	1
41	SL39076	PLAQUE	1
42	GR39060	PUSH-BUTTON	1
43	SL13045	DUCT LOCK	1
44	SL07470	NUT	1
45	SL18377	UNION / CONNECTOR	1
46	SL03441	GASKET	1
47	MP18378	CAP	1
48	SL03469	GASKET	1



← Back 1 page

PANTHER 28 CODE: pl1431 ac SN from 01K374

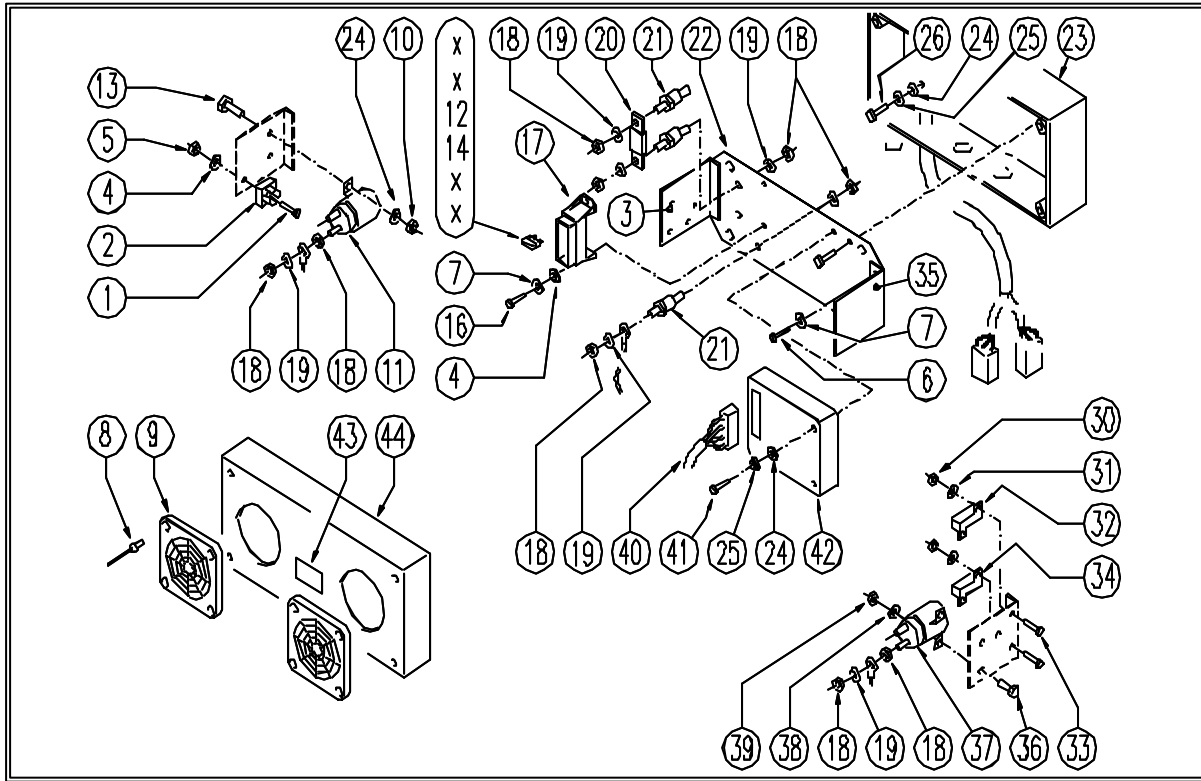

PANTHER 28 CODE: pl1431 ac SN from 01K374

REF.	CODE	DESCRIPTION	QTY
1	SL04149	SCREW	1
2	SL23081	BRIDGE / JUMPER	1
3	SL39082-1	BRACKET	1
4	SL06019	WASHER	8
5	SL05034	NUT	2
6	SL04226	SCREW	4
7	SL06107	WASHER	4
8	SL14039	RIVET	8
9	SL03578	GRATING	2
10	SL05043	NUT	2
11	SL23001	REMOTE CONTROL SWITCH	1
12	SL23892	FUSE	1
13	SL04081	SCREW	2
14	SL23650	FUSE	1
16	SL04186	SCREW	2
17	SL23894	FUSE HOLDER	1
18	SL05004	NUT	18
19	SL06083	WASHER	14
20	SL23740	FUSE	1
21	SL23103	SUPPORT	3
22	SL39082	PLATE	1
23	SL23716-2	BOX BASE	1

Next page →



← Back 1 page

PANTHER 28 CODE: pl1431 ac SN from 01K374			
REF.	CODE	DESCRIPTION	QTY
24	SL06034	WASHER	6
25	SL06094	WASHER	4
26	SL04371	SCREW	4
27	SL04327	SCREW	4
30	SL05019	NUT	4
31	SL06056	WASHER	4
32	SL23957	RESISTANCE	1
33	SL04179	SCREW	4
34	SL23397	RESISTANCE	1
35	SL39082-2	BRACKET	1
36	SL04092	SCREW	2
37	SL23735	REMOTE CONTROL SWITCH	1
38	SL06004	WASHER	2
39	SL05058	NUT	2
40	SL23221	CONNECTOR	1
41	SL04385	SCREW	2
42	SL23729	GEARCASE / BOARD	1
43	SL25187	LABEL	1
44	SL23716-1L	BOX COVER	1



← Back 1 page

PANTHER 28 CODE: pl1423 ad SN from 02A403

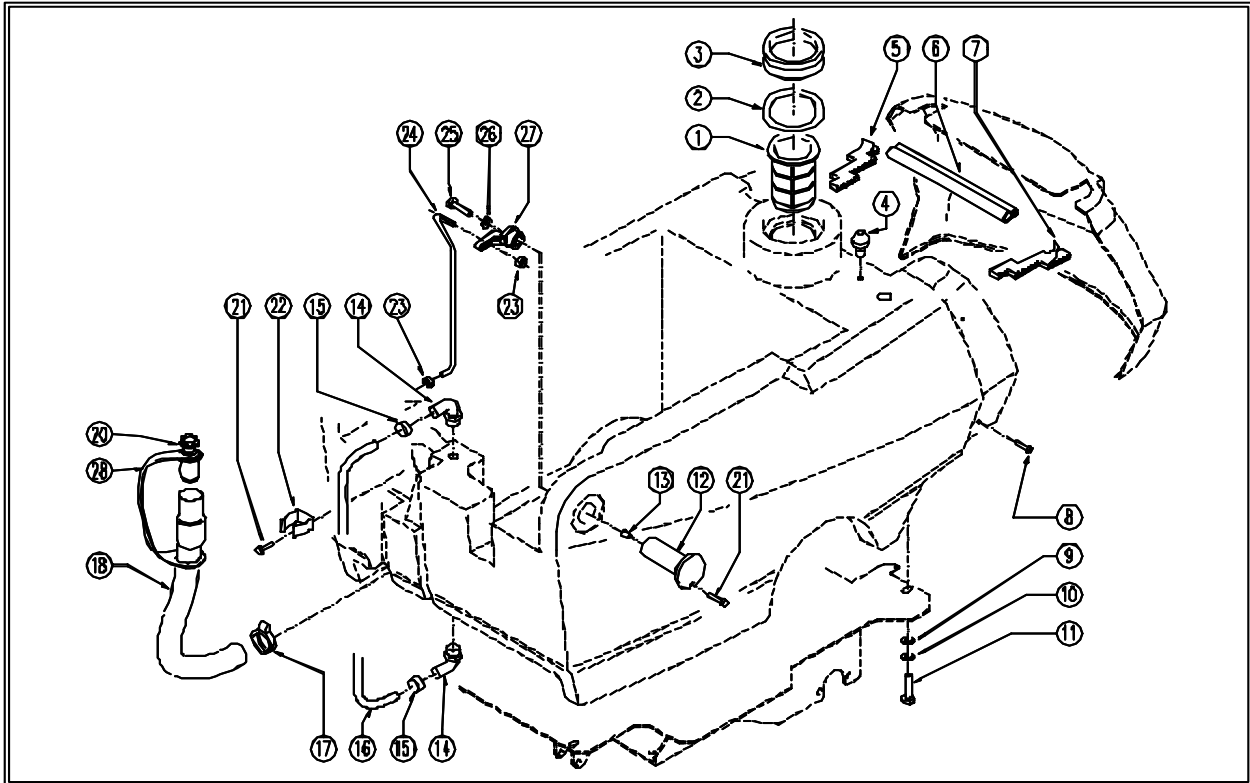

PANTHER 28 CODE: pl1423 ad SN from 02A403

REF.	CODE	DESCRIPTION	QTY
1	SL03526	FILTER	1
2	SL03575	GASKET	1
3	SL03566	GASKET	1
4	SL07529	PIN	1
5	SL03980	GASKET	1
6	SL03551	GASKET	1
7	SL03979	GASKET	1
8	SL04395	SCREW	4
9	SL06050	WASHER	4
10	SL06108	WASHER	4
11	SL04040	SCREW	4
12	SL17493-1	PIN	2
13	SL04171	INSERT	2
14	SL18232	UNION / CONNECTOR	2
15	SL14109	CLAMP	2
16	SL19097	HOSE	1
17	SL14063	CLAMP	1
18	SL19113-1	HOSE	1
20	SL18395	CAP	1
21	SL04371	SCREW	4
22	SL13118	DUCT LOCK	1

Next page →



← Back 1 page

PANTHER 28 CODE: pl1423 ad SN from 02A403			
REF.	CODE	DESCRIPTION	QTY
23	SL05041	NUT	2
24	SL39079	ROD	1
25	SL04180	SCREW	1
26	SL06015	WASHER	1
27	SL17491-1	LEVER	1
28	SL03577	CLAMP	1



← Back 1 page

PANTHER 28 CODE: pl1433N ab SN from 02A000

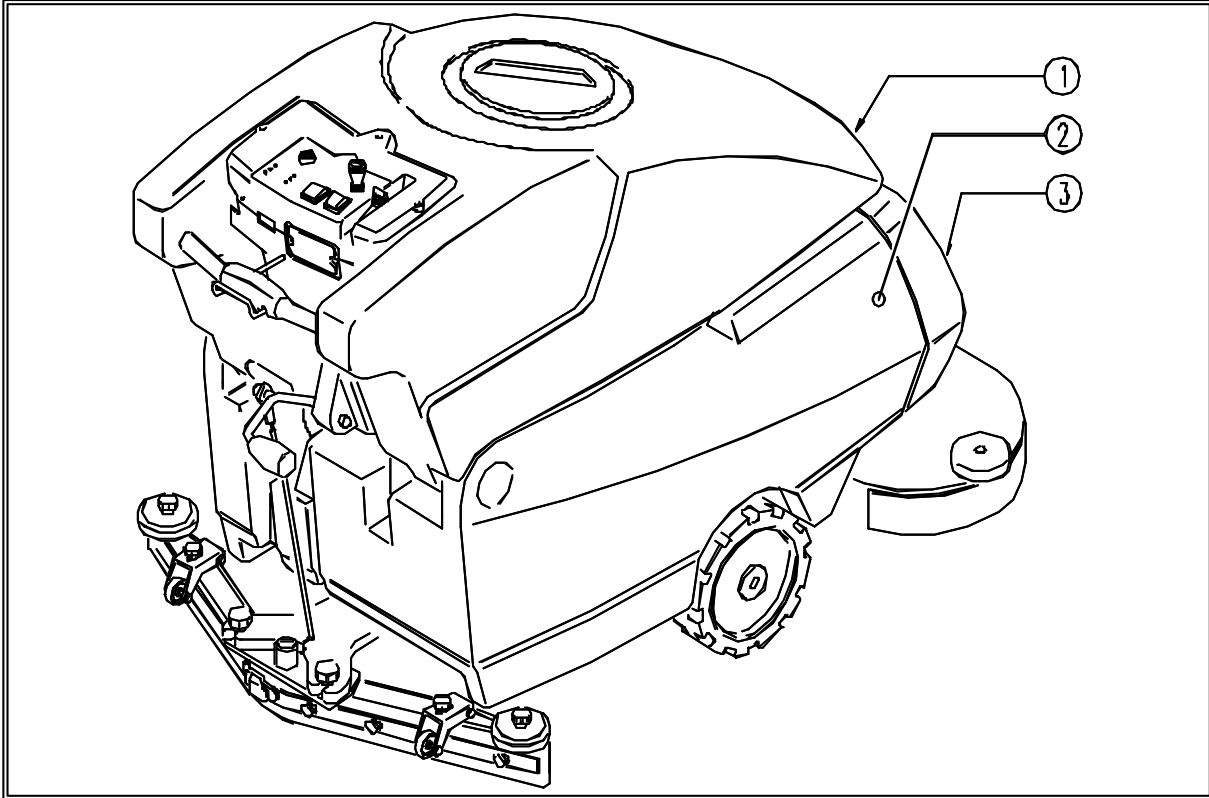

REF.	CODE	DESCRIPTION	QTY
1	SL17600AS	GREY TANK	1
1	SL17600BC	RED TANK	1
1	SL17600BL	BLUE TANK	1
2	SL17599	BLACK TANK	1
2	SL17599BL	BLUE TANK	1
3	SL17601	HOOD	1



← Back 1 page

PANTHER 28 CODE: pl1428 aa SN from 01B100

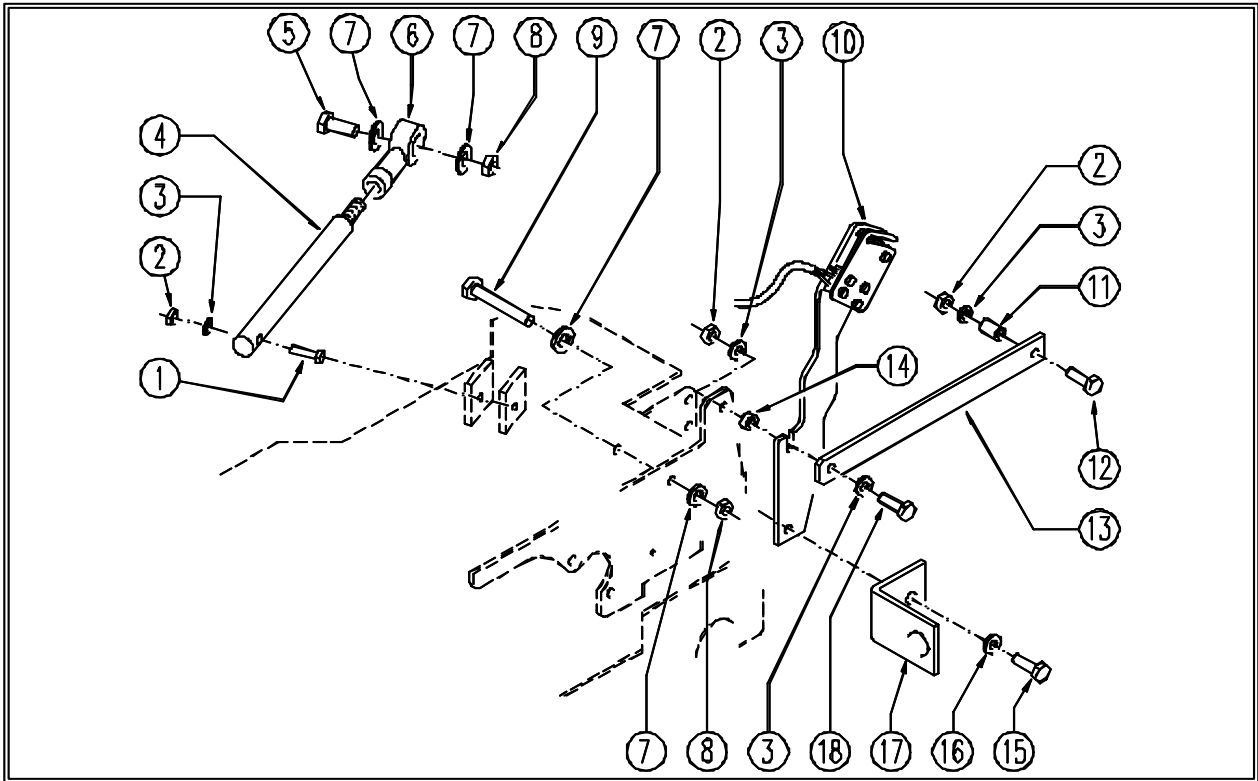

REF.	CODE	DESCRIPTION	QTY
1	SL04164	SCREW	1
2	SL05039	NUT	3
3	SL06041	WASHER	4
4	SL39072	LEVER	1
5	SL04304	SCREW	1
6	SL22004	ARTICULATION	1
7	SL06005	WASHER	4
8	SL05013	NUT	2
9	SL04151	SCREW	1
10	GR53004	SUPPORT ASSEMBLY	1
11	SL07112	SPACER	1
12	SL04127	SCREW	1
13	SL39073	LEVER	1
14	SL07150	SPACER	1
15	SL04134	SCREW	1
16	SL06083	WASHER	1
17	SL39112	SUPPORT	1
18	SL04075	SCREW	1



PANTHER 28 CODE: pl1429 aa SN from 01B100

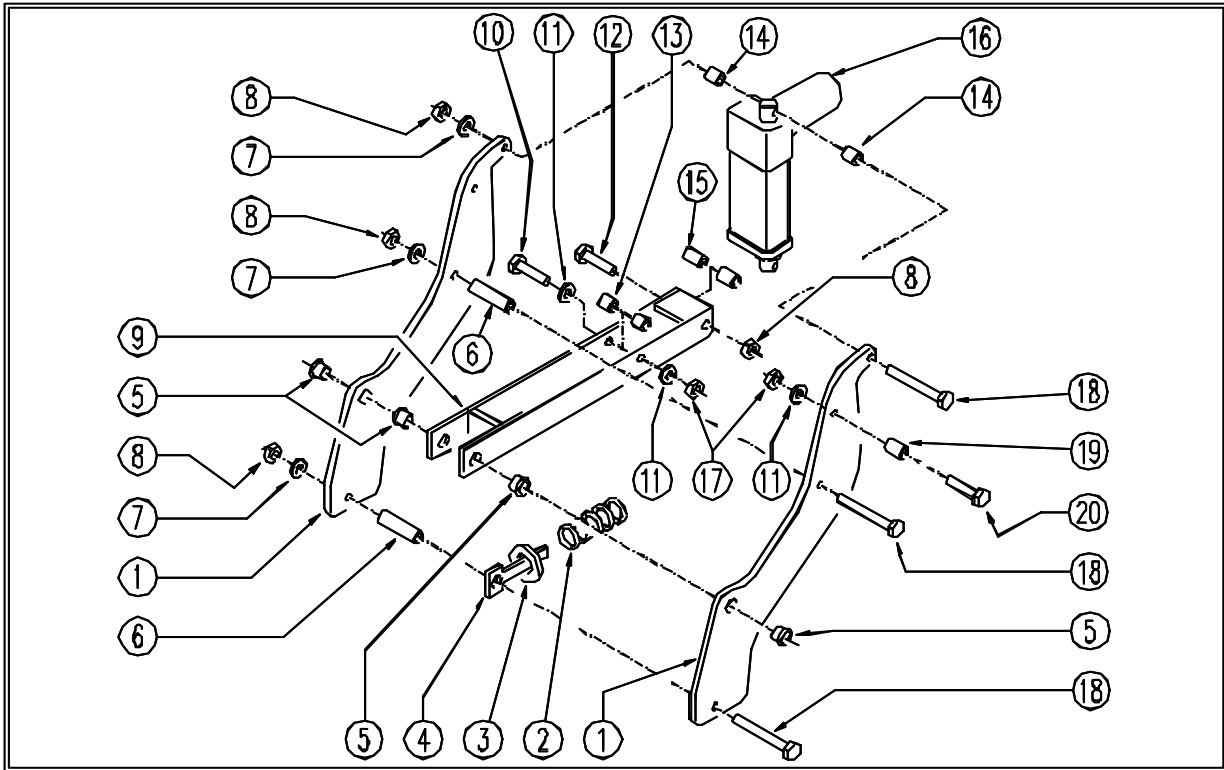

REF.	CODE	DESCRIPTION	QTY
1	SL39066	LEVER	2
2	SL13132	SPRING	1
3	SL06029	WASHER	1
4	SL39067	SPRING GUIDE	1
5	SL12072	BUSHING	4
6	SL07528	SPACER	2
7	SL06041	WASHER	3
8	SL05039	NUT	4
9	SL39074	LEVER	1
10	SL04387	SCREW	1
11	SL06022	WASHER	3
12	SL04200	SCREW	1
13	SL07318	SPACER	2
14	SL07527	SPACER	2
15	SL07063	SPACER	2
16	SL02204	ACTUATOR	1
17	SL05041	NUT	2
18	SL04201	SCREW	3
19	SL07165	SPACER	1
20	SL04133	SCREW	1

PANTHER 28 CODE: pl1425 af SN from 02C87

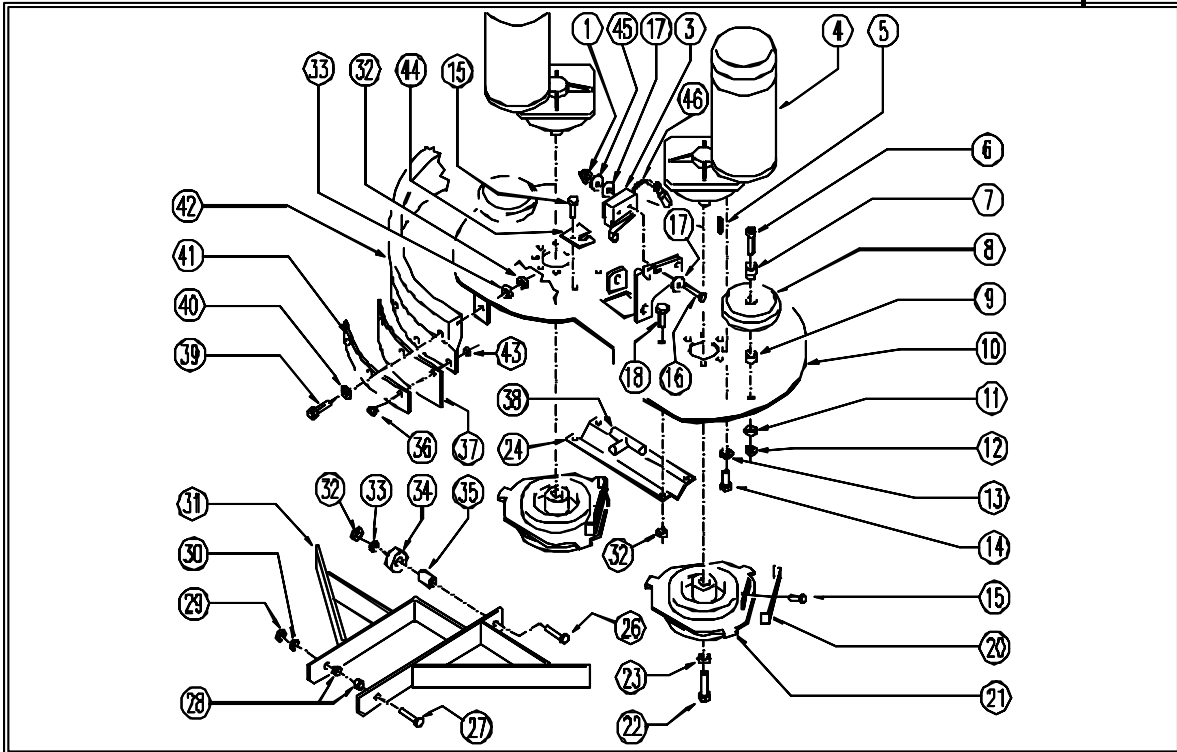

PANTHER 28 CODE: pl1425 af SN from 02C87

REF.	CODE	DESCRIPTION	QTY
1	SL05078	NUT	2
3	SL23200	MICROSWITCH	1
4	SL02251	GEARMOTOR	2
5	SL11002	TANG / TONGUE	2
6	SL04167	SCREW	2
7	SL07390	BUSHING	2
8	SL08040	WHEEL	2
9	SL07297	SPACER	2
10	SL39080	HEAD	1
11	SL06041	WASHER	3
12	SL05039	NUT	3
13	SL06093	WASHER	14
14	SL04180	SCREW	14
15	SL04079	SCREW	3
16	SL04402	SCREW	2
17	SL06031	WASHER	4
18	SL04278	SCREW	4
20	SL13135	SPRING	2
21	SL01042	FLANGE	2
22	SL04020	SCREW	2
23	SL06081	WASHER	2
24	SL39111	DISTRIBUTOR	1



← Back 1 page

PANTHER 28 CODE: p11425 af SN from 02C87

REF.	CODE	DESCRIPTION	QTY
26	SL04061	SCREW	1
27	SL04389	SCREW	1
28	SL07133	SPACER	2
29	SL05013	NUT	1
30	SL06005	WASHER	1
31	SL39123	BRACKET	1
32	SL05041	NUT	8
33	SL06022	WASHER	4
34	SL08058	SMALL WHEEL	1
35	SL07526	SPACER	1
36	SL04395	SCREW	6
37	SL03562	FLAP	2
38	SL18243	UNION / CONNECTOR	1
39	SL04324	SCREW	3
40	SL06039	WASHER	3
41	SL03570	FLAP PRESS	2
42	SL03531	GASKET	1
43	SL05029	NUT	6
44	SL39138	PLAQUE	1
45	SL06107	WASHER	2
46	SL53008-1	WIRING	1



← Back 1 page

PANTHER 28 CODE: pl1432 ac SN from 01G200

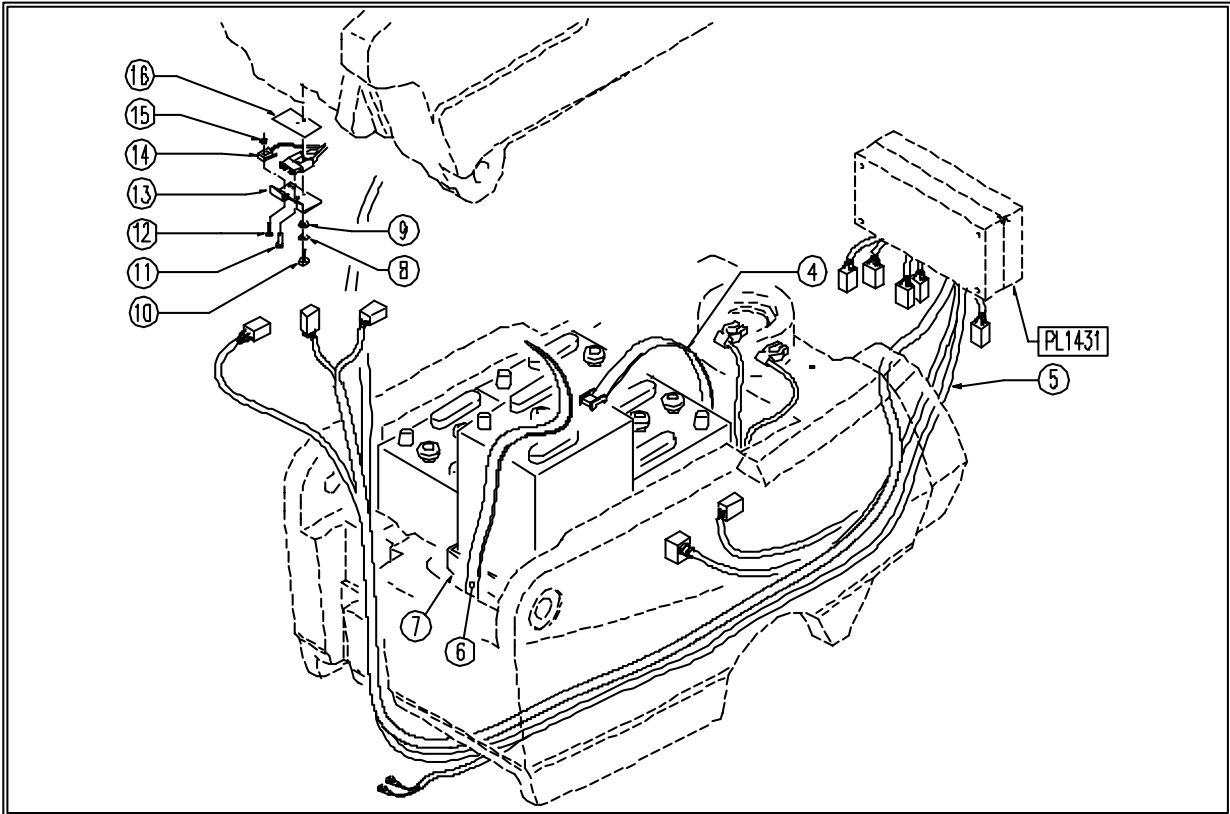

REF.	CODE	DESCRIPTION	QTY
4	SL14356	BELT	2
5	GR23716	WIRING	1
6	SL14357	BELT	2
7	SL17607	BATTERY PLATE	4
8	SL06033	WASHER	2
9	SL06032	WASHER	2
10	SL04320	SCREW	2
11	SL04393	SCREW	1
12	SL04086	SCREW	2
13	SL39122	SUPPORT	1
14	SL53031-L	MICROSWITCH	1
15	SL05031	NUT	2
16	SL03572	GUARD	1



← Back 1 page

PANTHER 28 CODE: pl1424 aa SN from 01B100

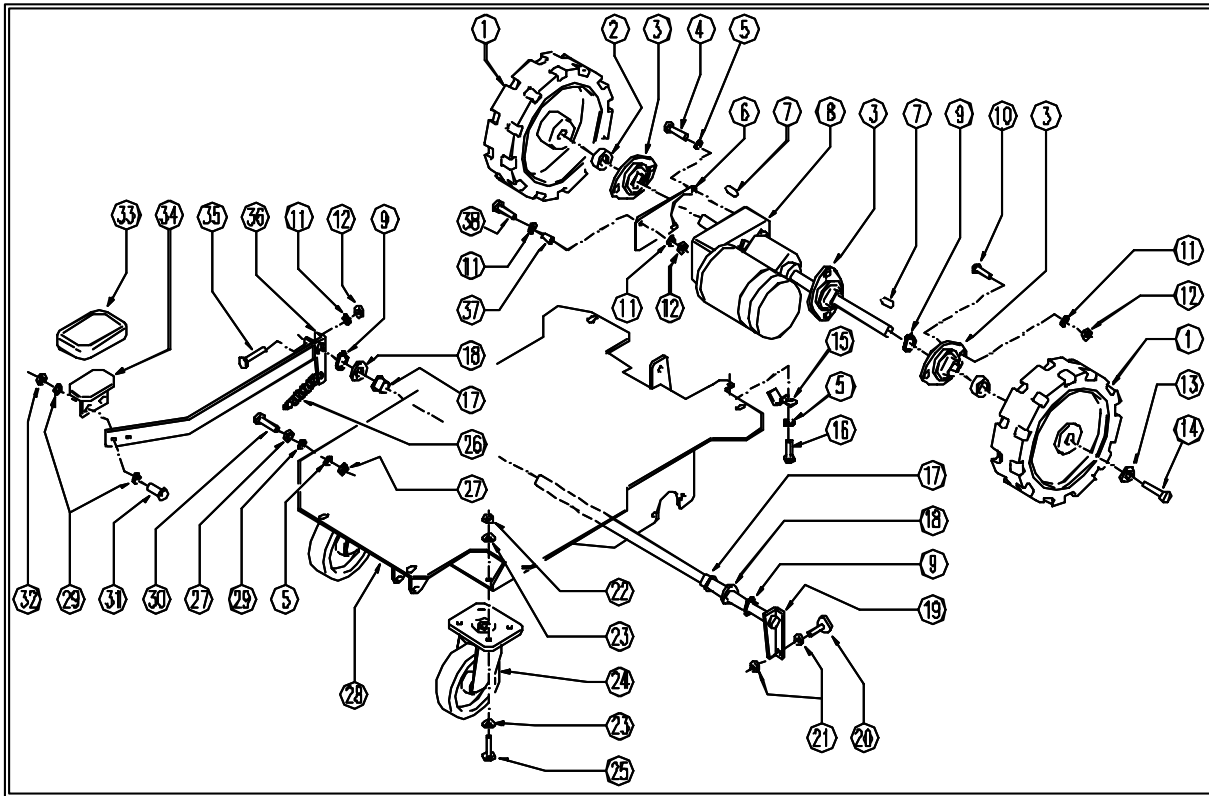

PANTHER 28 CODE: pl1424 aa SN from 01B100

REF.	CODE	DESCRIPTION	QTY
1	SL08054	WHEEL	2
2	SL12031-1	SPACER	2
3	SL12031	BEARING	3
4	SL04135	SCREW	2
5	SL06093	WASHER	4
6	SL39085	PLATE	1
7	SL11105	TANG / TONGUE	2
8	SL02250	MOTOR	1
9	SL11094	RING	3
10	SL04355	SCREW	6
11	SL06041	WASHER	9
12	SL05039	NUT	7
13	SL06069	WASHER	2
14	SL04269	SCREW	2
15	SL14353	CLIP	1
16	SL04180	SCREW	1
17	SL12035	BEARING	2
18	SL06079	WASHER	2
19	SL39075	BRAKE AXLE	1
20	SL20059	PLUG / STOPPER	2
21	SL05048	NUT	4

Next page →



← Back 1 page

PANTHER 28 CODE: pl1424 aa SN from 01B100

REF.	CODE	DESCRIPTION	QTY
22	SL05032	NUT	8
23	SL06011	WASHER	16
24	SL08007	SMALL WHEEL	2
25	SL04132	SCREW	8
26	SL13011	SPRING	1
27	SL05017	NUT	2
28	SL39065	FRAME	1
29	SL06022	WASHER	5
30	SL04144	SCREW	1
31	SL04002	SCREW	2
32	SL05074	NUT	2
33	SL20013	RUBBER SHIM	1
34	SL09133	PEDAL	1
35	SL04164	SCREW	1
36	SL39077	LEVER	1
37	SL07387	SPACER	1
38	SL04075	SCREW	1



PANTHER 28 CODE: pl1427 aa SN from 01B100

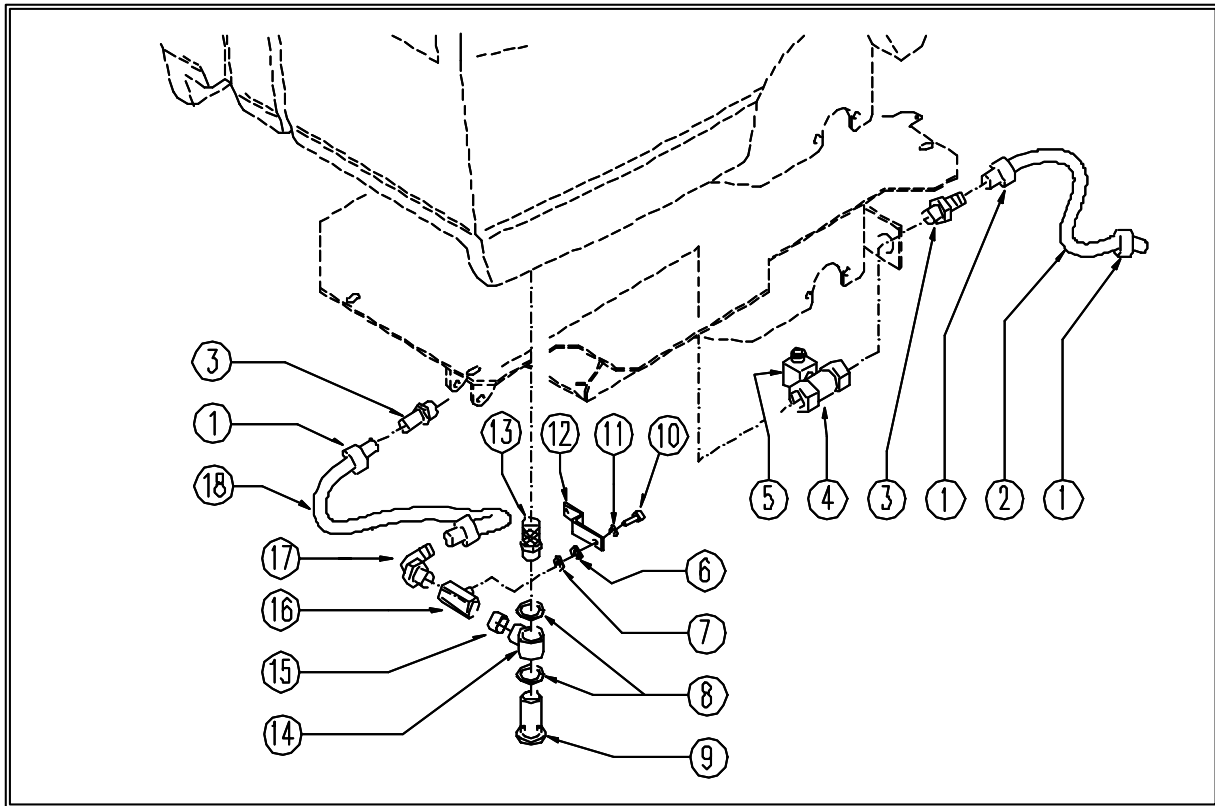

REF.	CODE	DESCRIPTION	QTY
1	SL14036	CLAMP	4
2	SL19334	HOSE	1
3	SL18398	UNION / CONNECTOR	2
4	SL18394	ELECTROVALVE	1
5	SL23212	CONNECTOR	1
6	SL06083	WASHER	1
7	SL06041	WASHER	1
8	SL03536	WASHER	2
9	SL18257-L	SCREW	1
10	SL04341	SCREW	1
11	SL06031	WASHER	1
12	SL39003	LEVER	1
13	SL18405	FILTER	1
14	SL18256	UNION / CONNECTOR	1
15	SL07209K	SPACER	1
16	SL18380	TAP	1
17	SL18403	UNION / CONNECTOR	1
18	SL19287	HOSE	1



← Back 1 page

PANTHER 28 CODE: pl1452 ab SN from 01E600

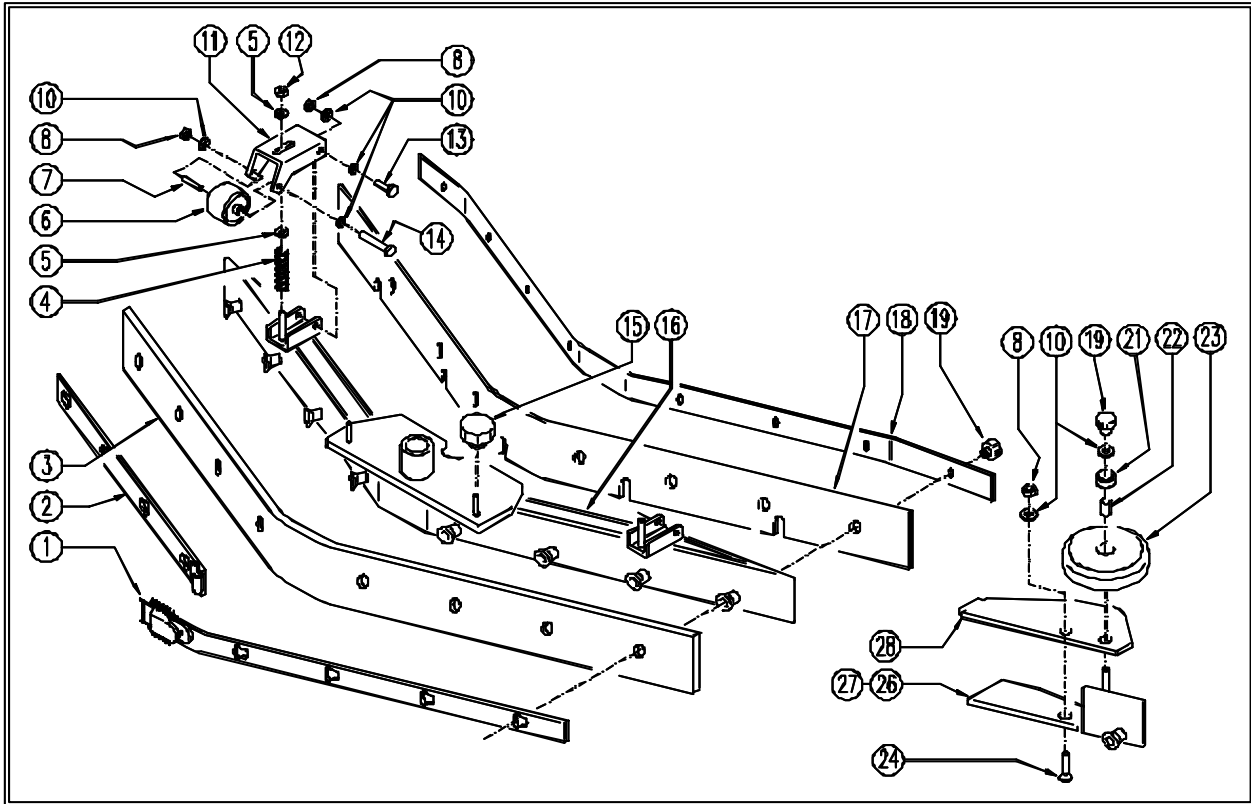

PANTHER 28 CODE: pl1452 ab SN from 01E600

REF	CODE	DESCRIPTION	QTY
	GR39027-85A	SQUEEGEE UNIT	
1	SL39141	BLADE HOLDER	1
2	SL39142	BLADE HOLDER	1
3	SL03563	BLADE	1
4	SL13103	SPRING	2
5	SL06041	WASHER	4
6	SL08058	WHEEL	2
7	SL07526	SPACER	2
8	SL05074	NUT	8
10	SL06022	WASHER	16
11	SL39033	SUPPORT	2
12	SL05039	NUT	2
13	SL04135	SCREW	4
14	SL04061	SCREW	2
15	SL20060	HANDLE	2
16	SL39136	BODY	1
17	SL03564	BLADE	1
18	SL39144	BLADE HOLDER	1
19	SL20058	HANDLE	10
21	SL17608	BUSHING/BUSH	2

Next page →



← Back 1 page

PANTHER 28 CODE: pl1452 ab SN from 01E600			
REF	CODE	DESCRIPTION	QTY
22	SL07065	SPACER	2
23	SL08040	WHEEL	2
24	SL04098	SCREW	2
26	SL39140	LEFT EXTENSION	1
27	SL39139	RIGHT EXTENSION	1
28	SL39143	SUPPORT	2



← Back 1 page

PANTHER 28 CODE: pl1430 ab SN from 01D113

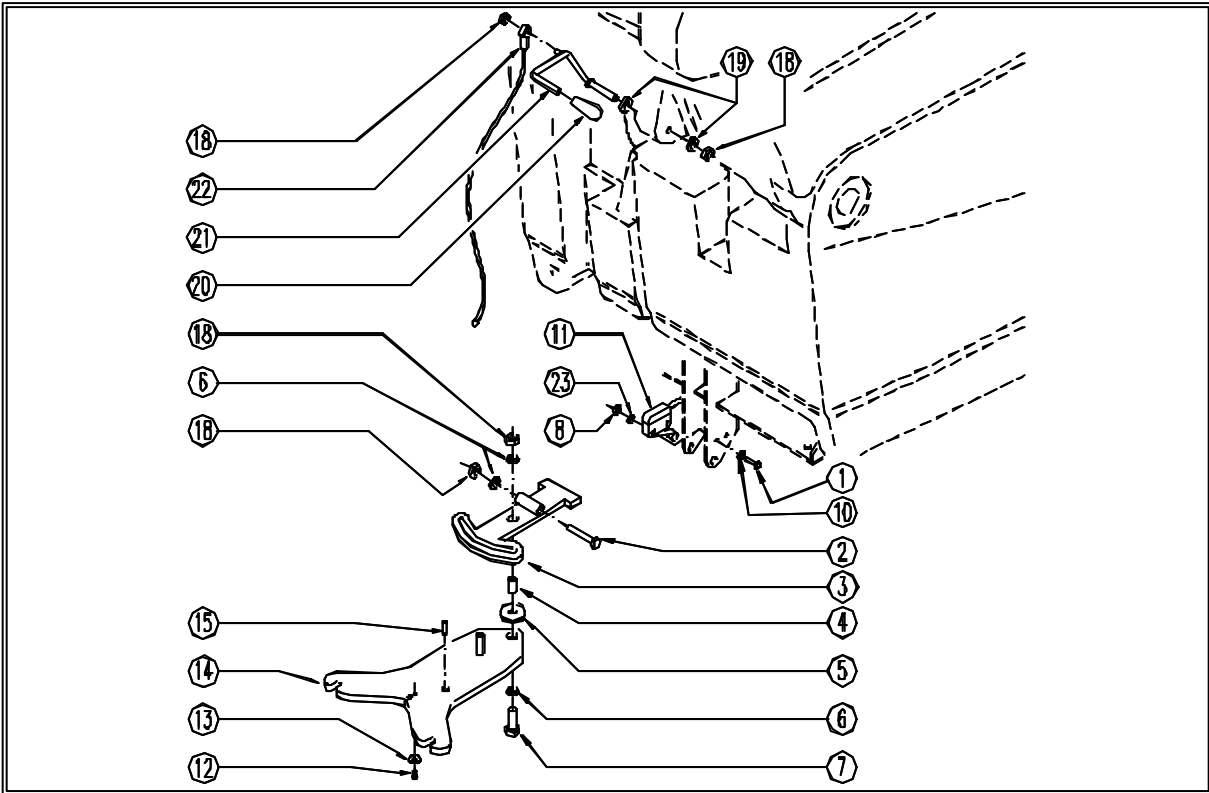

REF.	CODE	DESCRIPTION	QTY
1	SL04197	SCREW	2
2	SL04229	SCREW	1
3	SL39071	ARM	1
4	SL07427	BUSHING / BUSH	1
5	SL06062	WASHER	1
6	SL06041	WASHER	3
7	SL04127	SCREW	1
8	SL05078	NUT	2
10	SL06019	WASHER	2
11	SL23200	MICROSWITCH	1
12	SL04079	SCREW	1
13	SL06084	WASHER	1
14	SL39099	BRACKET	1
15	SL11126	SCREW	1
18	SL05039	NUT	3
19	SL06025	WASHER	2
20	SL20007	KNOB (o HANDWHEEL)	1
21	SL39036	LEVER	1
22	SL14248	CABLE	1
23	SL06107	WASHER	2



← Back 1 page

PANTHER 28 CODE: pl1434 ab SN from 01K374

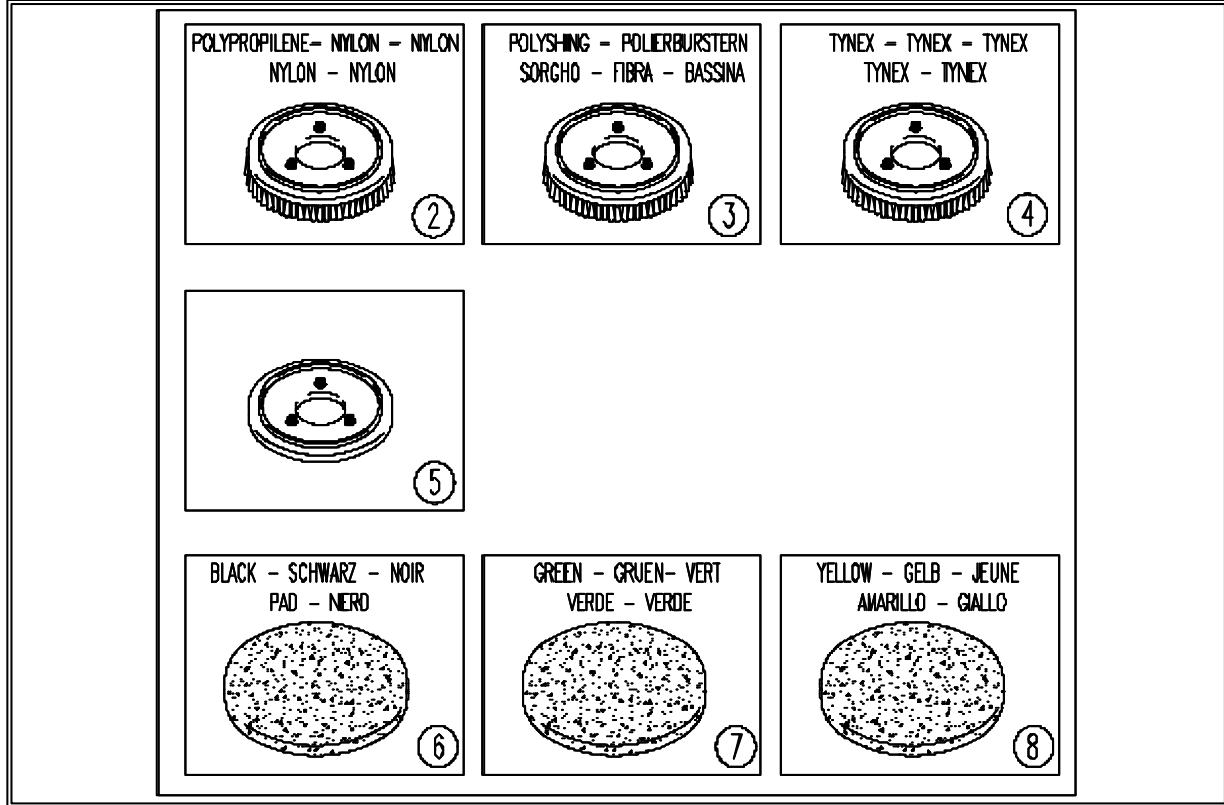

REF.	CODE	DESCRIPTION	QTY
2	AL03810-2	POLYPROPYLENE BRUSH	
3	AL03811-2	POLYSHING BRUSH	
4	AL03812-2	TYNEX BRUSHES	
5	AL03813	PAD DRIVER	
6	AL02709	STRIPPING PAD(BLACK)	
7	AL02710	STRIPPING PAD(GREEN)	
8	AL02711	STRIPPING PAD(YELLOW)	



PANTHER 28 CODE: EPF02380N-1 ac SN from 01K374

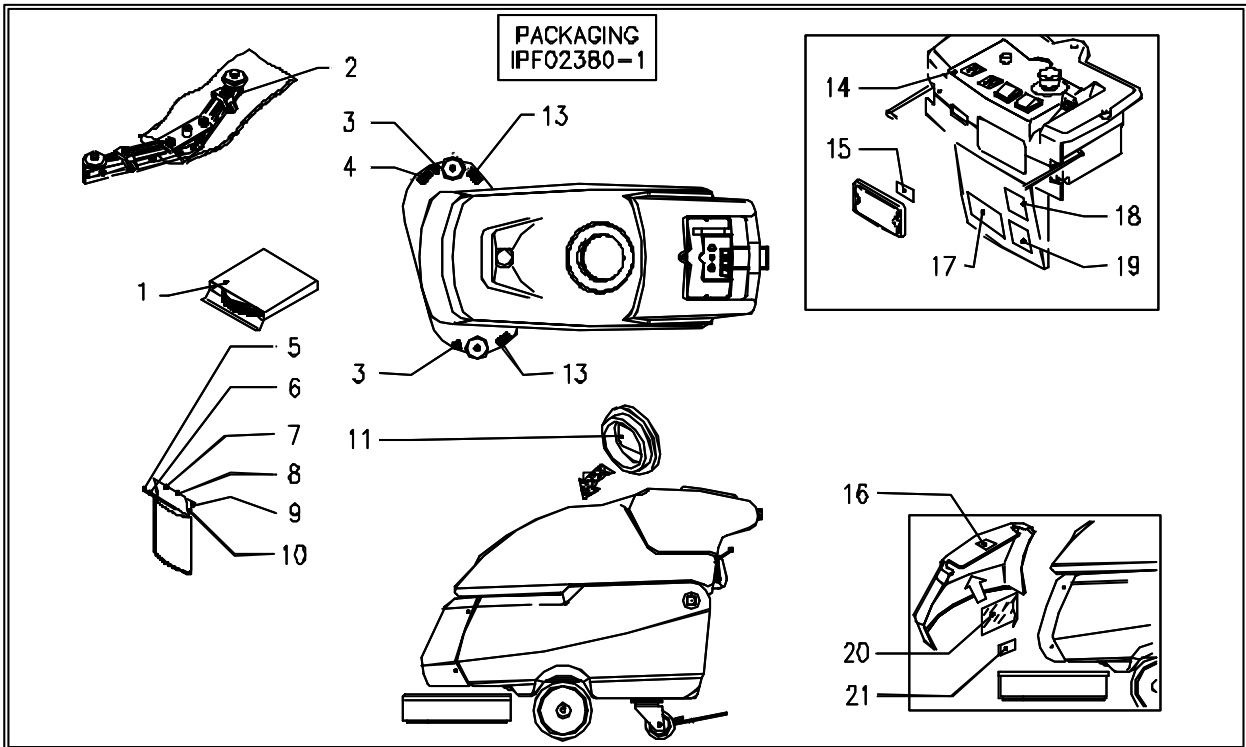

REF.	CODE	DESCRIPTION	QTY
1	AL03810	BRUSH	2
2	GR39027-85A	SQUEEGEE	1
3	SL25364	LABEL	2
4	SL25366	LABEL	1
5	SL25968N-1	OPERATOR'S MANUAL	1
6	SL25984N	SPARE PARTS	1
7	SL25401-2	LABEL - DOCUMENT	1
8	SL25401-3	LABEL - DOCUMENT	1
9	SL25401-8	LABEL - DOCUMENT	1
10	SL25303	DOCUMENT	1
11	SL25056	LABEL	1
13	SL25369	LABEL	2
14	SL25887	LABEL	1
15	SL25994	LABEL	1
16	SL25187	LABEL	1
17	SL25401-6	LABEL - DOCUMENT	1
18	SL25177	LABEL	1
19	SL25053	LABEL	1
20	GR27195	ELEC. DIAGRAM ENVELOPE	1
21	SL25995	LABEL	1



Back 1 page

PANTHER 28 CODE: IPF02380-1 ac SN from 02C80

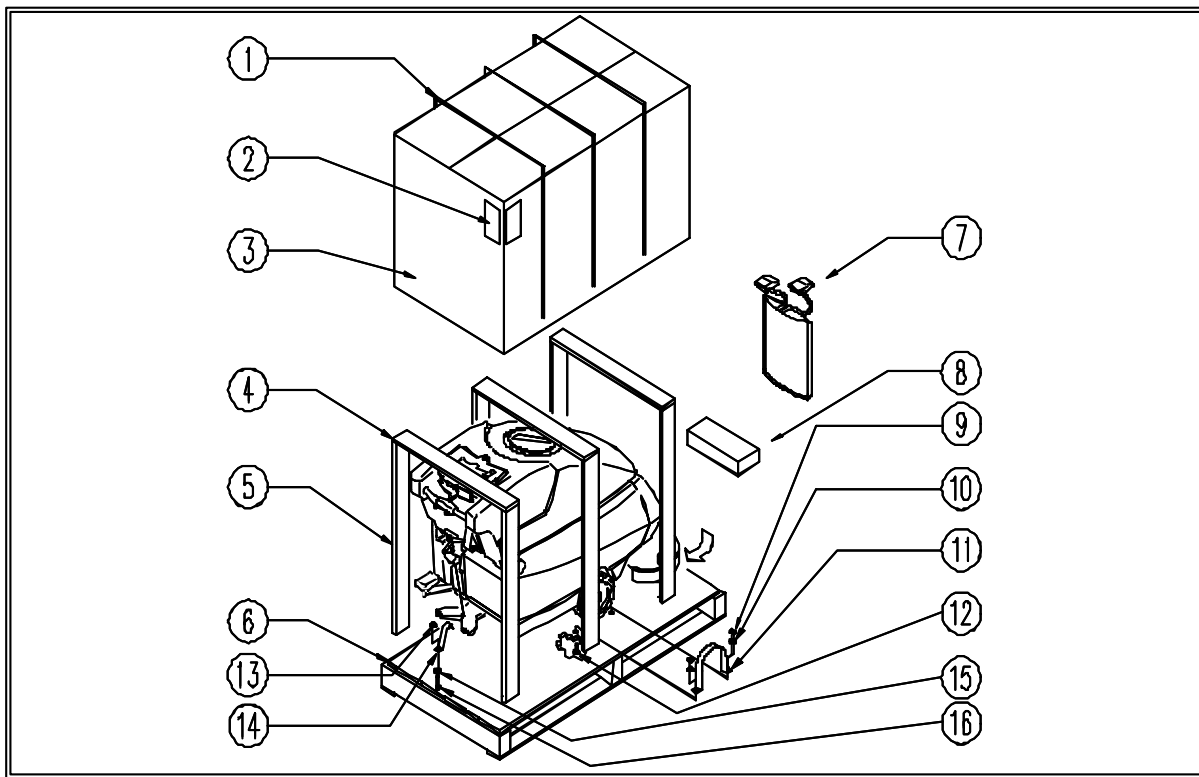

REF.	CODE	DESCRIPTION	QTY
1	MP14300	STRAP	3
2	SL25401-1	LABEL	2
3	SL26089N	CARDBOARD	1
4	SL26107	LATH / SPLINE	3
5	SL26122	LATH / SPLINE	6
6	SL26106	PALLET	1
7	SL23838	BRIDGE / JUMPER	3
8	SL26137	LATH / SPLINE	1
9	SL05001	NUT	4
10	SL06087	WASHER	4
11	SL39120	BRACKET	2
12	SL04001	SCREW	4
13	SL05039	NUT	1
14	SL39198	BRACKET	1
15	SL06086	WASHER	1
16	SL04200	SCREW	1



PANTHER 28 CODE: wd27195 ac SN from 02C80

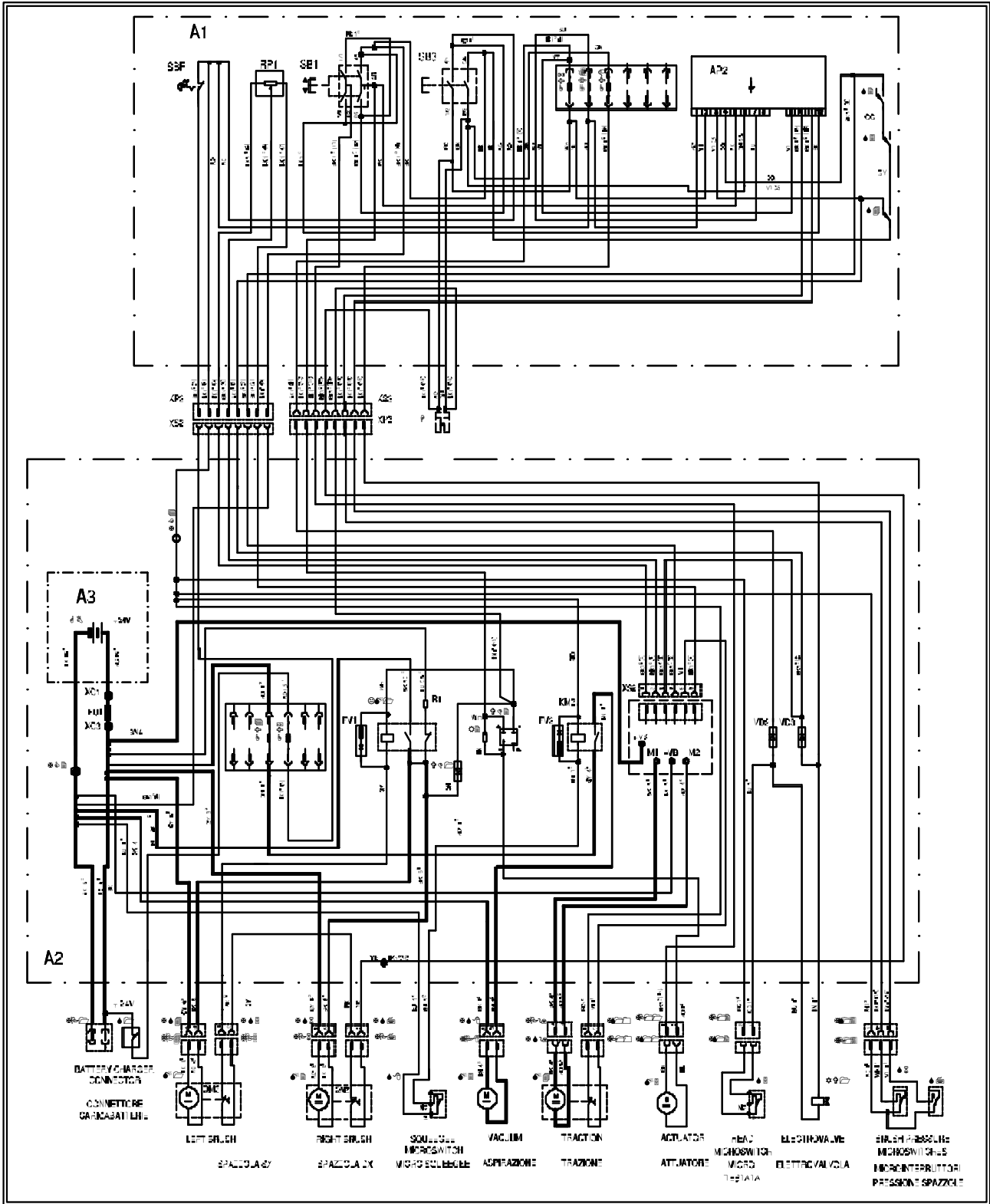

PANTHER 28 CODE: wd27195-1 ad SN from 02C80

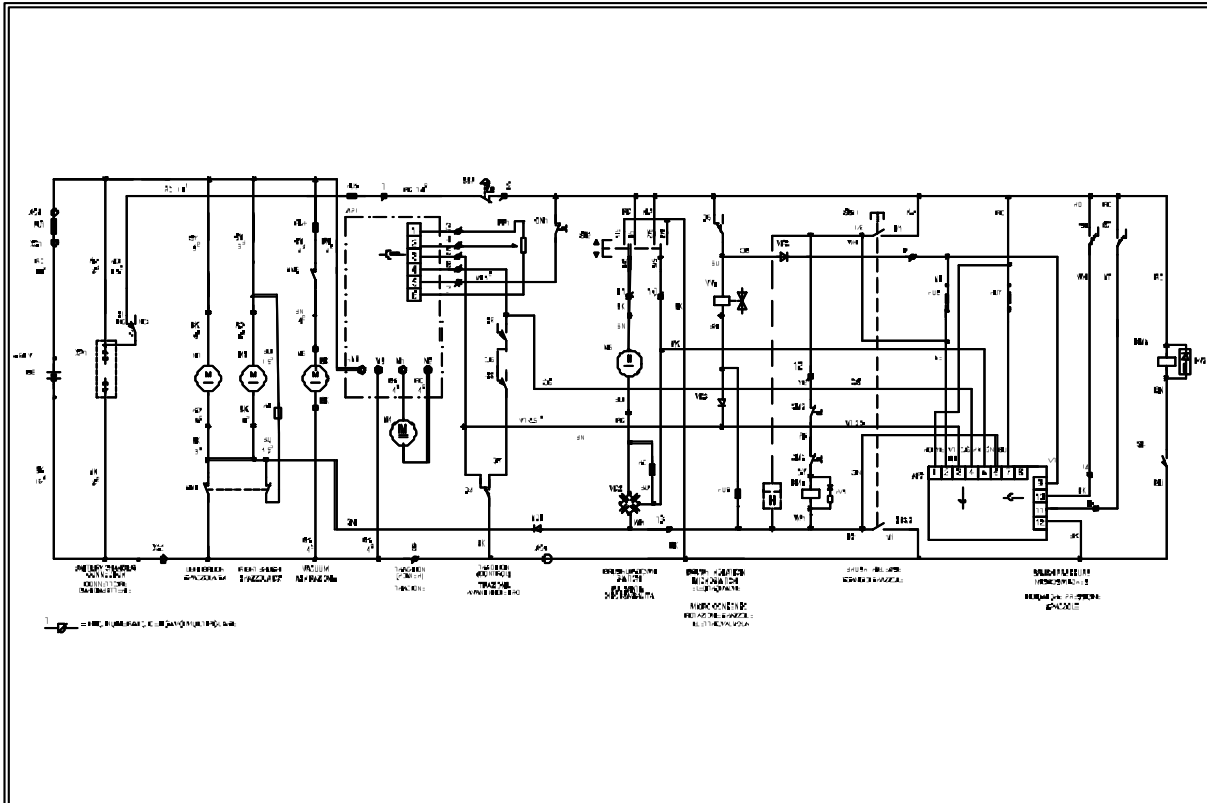

PANTHER 28 CODE: wd27195-1 ad SN from 02C80

REF.	CODE	DESCRIPTION	QTY
AP1	SL23729	GEARCASE / BOARD	
AP2	SL23738	GEARCASE / BOARD	
FU1	SL23740	FUSE	
FU4	SL23148	FUSE	
FU5	SL23650	FUSE	
FV1	SL23758-1	DIODE	
FV2	SL23758-1	DIODE	
GB		BATTERY	
H	SL23984J	HOUR METER (OPTIONAL)	
HL1	SL23031	INDICATOR	
KM1	SL23735	REMOTE CONTROL SWITCH	
KM3	SL23001	RELAY	
M1	SL02251	MOTOR	
M2	SL02251	MOTOR	
M3	SL02303-J	MOTOR	
M4	SL02250	MOTOR	
M5	SL02204	MOTOR	
QM1		THERMAL PROTECTION	
QM2		THERMAL PROTECTION	
QM3		THERMAL PROTECTION	



← Back 1 page

PANTHER 28 CODE: wd27195-1 ad SN from 02C80

REF.	CODE	DESCRIPTION	QTY
R1	SL23397	RESISTANCE	
R2	SL23957	RESISTANCE	
RP1	SL23872	POTENTIOMETER	
S1	SL23599-L	MICROSWITCH	
S2	SL23109	MICROSWITCH	
S3	SL23109	MICROSWITCH	
S4	SL23109	MICROSWITCH	
S5	SL23200	MICROSWITCH	
S6	SL23599	MICROSWITCH	
S7	SL23599	MICROSWITCH	
S8	SL23200	MICROSWITCH	
SB2	SL23649	PUSH-BUTTON	
SB3	SL23708	PUSH-BUTTON	
SBF		PUSH-BUTTON	
VD1	SL23289	DIODE	
VD2	SL23081	BRIDGE / JUMPER	
VD3	SL23289	DIODE	
XC1	SL23103	INSULATOR	
XC2	SL23103	INSULATOR	
XC3	SL23103	INSULATOR	
XP1	SL23010K	CONNECTOR	
XC4	SL23414	CLAMP	



Eagle Power™ Products Group

Warranty Policy

Limited Warranty

Eagle Power Products (EPP) warrants new cleaning equipment against defects in material and workmanship under normal use and service to the original purchaser as detailed below.

10 Years

Subject to the conditions stated below, EPP warrants polyethylene tanks and housings to be free from defects in materials and workmanship for a period of ten years.

3 Years

Subject to the conditions stated below, EPP warrants all automatic scrubber components to be free from defects in materials and workmanship for a 3-year period. Parts replaced or repaired are warranted for the remainder of the original warranty period.

1 Year

Subject to the conditions stated below, EPP warrants all other cleaning equipment components to be free from defects in materials and workmanship for a 1-year period. Parts replaced or repaired are warranted for the remainder of the original warranty period. Batteries are prorated for one year.

EPP will furnish and charge for replacement parts, including transportation, to the original owner through an EPP authorized service center. If the part is returned within 30 days and is found defective, the owner will be credited for the cost of the replacement part including shipping and handling.

Labor charges are covered for one year from the date of purchase if provided by an authorized EPP service center. Travel is covered for 90 days for battery operated equipment only.

Wear items exempt from warranty include belts, carbon brushes, power cords, wheels, pad drivers, clutch plates, brushes, pads, handle grips, filters, screens, throttle cables, and squeegees.

This warranty shall not apply to failures caused by misuse or abuse, improper maintenance as stated in the operation manuals, use of unauthorized repair parts, repairs by other than an EPP authorized service center, and damage in transit.

EPP disclaims and denies any liability for any direct, indirect, special incidental or consequential damage which may be suffered as a result of sale, delivery, servicing, use, loss of any product, downtime, labor, freight, or other charges not expressly included herein.

Date Purchased: _____

Serial Number: _____

Serial Number: _____

Please be sure to record this information. This information will be necessary for future warranty claims.



1174 Northland Drive Mendota Heights, MN 55120
651.686.5399 Fax 651.686.5695
www.eaglepower.com

Eagle Power Products Sales and Service Provided by: