



## Electronic Service Manuals

This electronic document is provided as a service to our customers. We do not create the contents of the information contained in this document. Should you have detailed questions pertaining to the information contained in this document, you may contact Michco, or the manufacturer which provided the original information in this electronic deliverable. Michco's only part in this electronic deliverable was the electronic assembly process. By providing this manual on line we are not guaranteeing parts availability.

You may contact Michco through the following methods:

Phone (517) 484-9312 or (800) 331-3339

2011 N. High St. -- Lansing, Michigan -- 48906

Fax: (517) 484-9836

Email: [CustServe@Michco.com](mailto:CustServe@Michco.com)

Web site: [www.Michco.Com](http://www.Michco.Com)

Parts Web site: [www.FloorMachineParts.Com](http://www.FloorMachineParts.Com)

Order Parts on Line at:

**[www.FloorMachineParts.Com](http://www.FloorMachineParts.Com)**

Directly to Parts & Service:

By Email: **[Shop@Michco.com](mailto:Shop@Michco.com)**

By Fax: (517) 702-2041

By Voice: Use numbers above.

**Serving the Cleaning Industry Since 1922**

Notice: All copyrighted material remains property of original owners, all trademarks are property of respective owners. Manuals are subject to Manufacturer's reproduction limitations. Originals or reproductions were provided by manufacturers through a request. We make no warranty as to the correctness of information provided in this document and you assume all risk. By placing these manuals on line we are not declaring our corporation to be an manufacturer authorized dealer or provider, please check our web site for authorized manufacturers we represent.

# Eagle Power

## BOXER AUTOMATIC SWEEPER/ SCRUBBER



# PARTS MANUAL

REV A

January 2003

## BOXER-AUTOMATIC SWEEPER/SCRUBBER

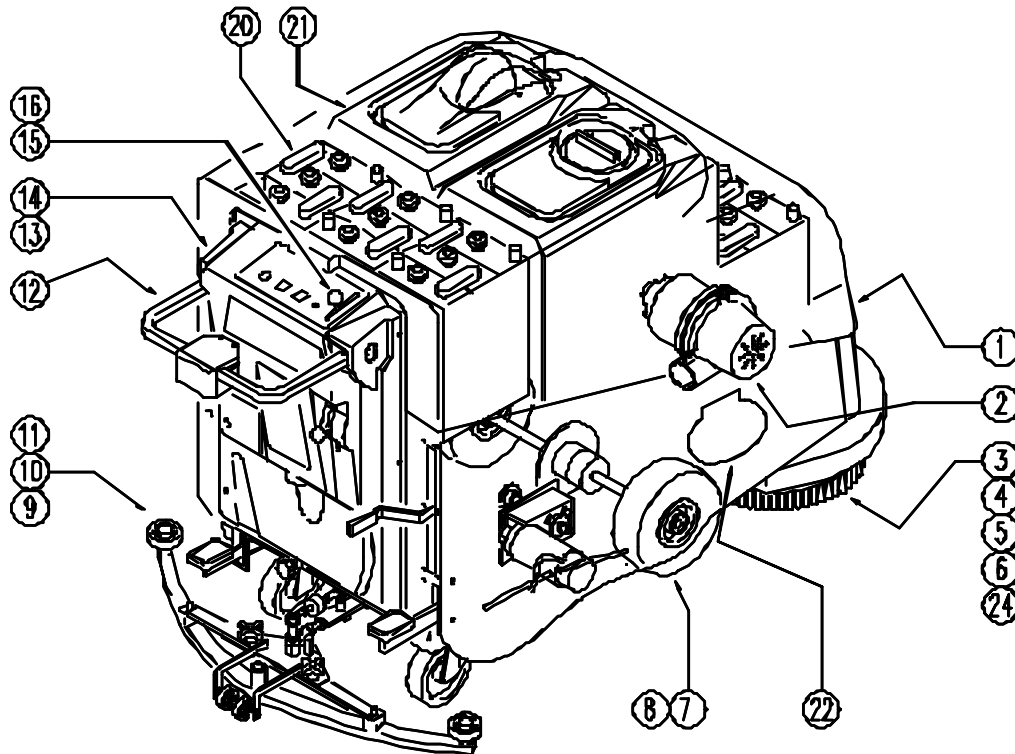

## BOXER-AUTOMATIC SWEEPER/SCRUBBER

POS.	PART #	DESCRIPTION
1	PL1021	FRAME
2	PL1020	ASPIRATOR
3	PL1029	HEAD LIFT
4	PL1034	HEAD 95: AXLE PULLEY
5	PL1033	HEAD 95: MOTOR
6	PL1032	HEAD 95: FLAP AND BOX
7	PL1035	DRIVE
8	PL1025	BRAKE
9	PL1030	SQUEEGEE
10	PL1031	SQUEEGEE SUPPORT
11	PL1028	SQUEEGEE LIFT
12	PL1023	HANDGRIP UNIT
13	PL1036	CONTROL PANEL
14	PL1024	ELECTRIC UNIT
15	PL1026	TAP
16	PL1380	HYDRAULIC UNIT
20	PL1022	BATTERY

**BOXER-AUTOMATIC SWEEPER/SCRUBBER**

<b>POS.</b>	<b>PART #</b>	<b>DESCRIPTION</b>
21	PL1027	TANK
22	PL1083	EXTERNAL PARTS
23	PL1084N	PACKING
24	PL1237	BRUSH
	WD27182	ELEC. WIRING DIAGRAM
	WD27182-1	ELEC. SCHEMATIC DIAGRAM

## BOXER-AUTOMATIC SWEEPER/SCRUBBER-PL1021

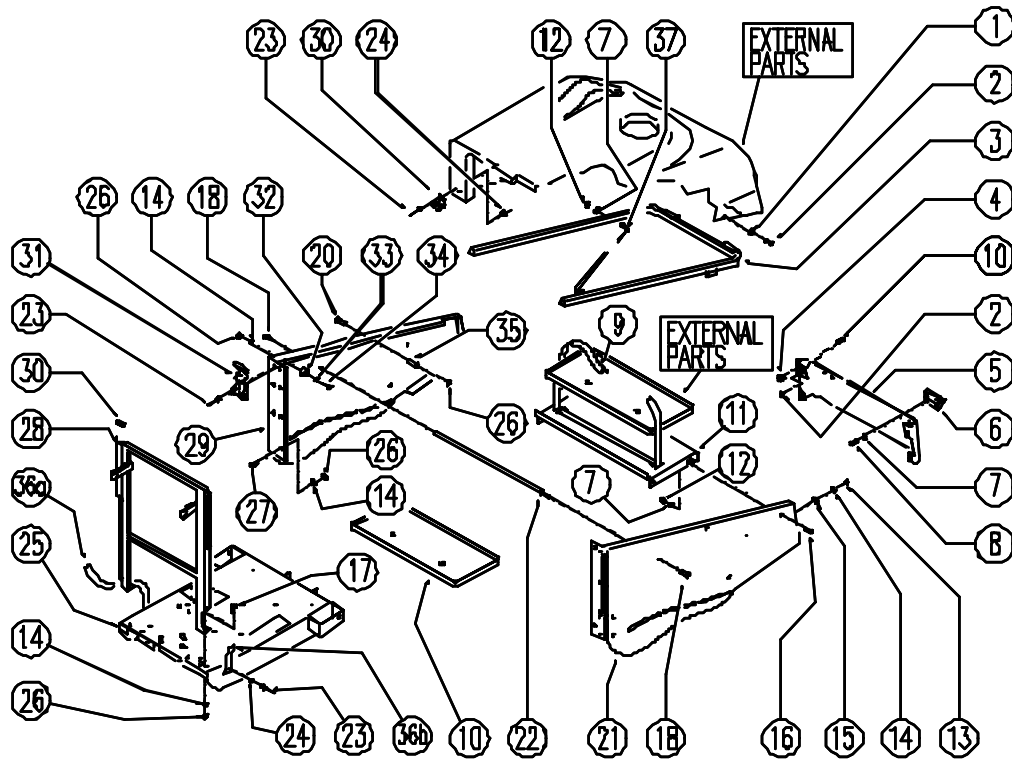

### BOXER-AUTOMATIC SWEEPER/SCRUBBER-PL1021

POS.	PART #	DESCRIPTION	QTY.
1	SL06019	WASHER	6
2	SL04079	SCREW	7
3	SL09862	REINFORCEMENT	1
4	SL07456	PIN	2
5	SL09859	BAND	1
6	SL14323	HINGE	2
7	SL06003	WASHER	9
8	SL04076	SCREW	4
9	SL14332	BELT	1
10	SL04065	SCREW	2
11	SL09861	BATTERY BEARING SURFACE	1
12	SL05001	NUT	5
13	SL04180	SCREW	4
14	SL06004	WASHER	10
15	SL07405	BUSHING / BUSH	2
16	SL04105	SCREW	4
17	SL04002	SCREW	1

**BOXER-AUTOMATIC SWEEPER/SCRUBBER-PL1021**

<b>POS.</b>	<b>PART #</b>	<b>DESCRIPTION</b>	<b>QTY.</b>
18	SL04077	SCREW	2
20	SL04370	SCREW	5
21	SL09857	BODY SIDE	1
22	SL07404	AXLE	1
23	SL14156	RIVET	14
24	SL06034	WASHER	12
25	SL09856	BASEMENT	1
26	SL05039	NUT	9
27	SL04190	SCREW	3
28	SL09860-2	FRAME	1
29	SL09858	BODY SIDE	1
30	SL14336	CAP	2
31	RP02387	HOOK	2
32	SL07338	PLUG / STOPPER	2
33	SL06039	WASHER	2
34	SL04073	SCREW	2
35	SL07241	BUSHING / BUSH	1
36a	SL14035	BELT	1
36b	SL14096	BELT	1

## BOXER-AUTOMATIC SWEEPER/SCRUBBER

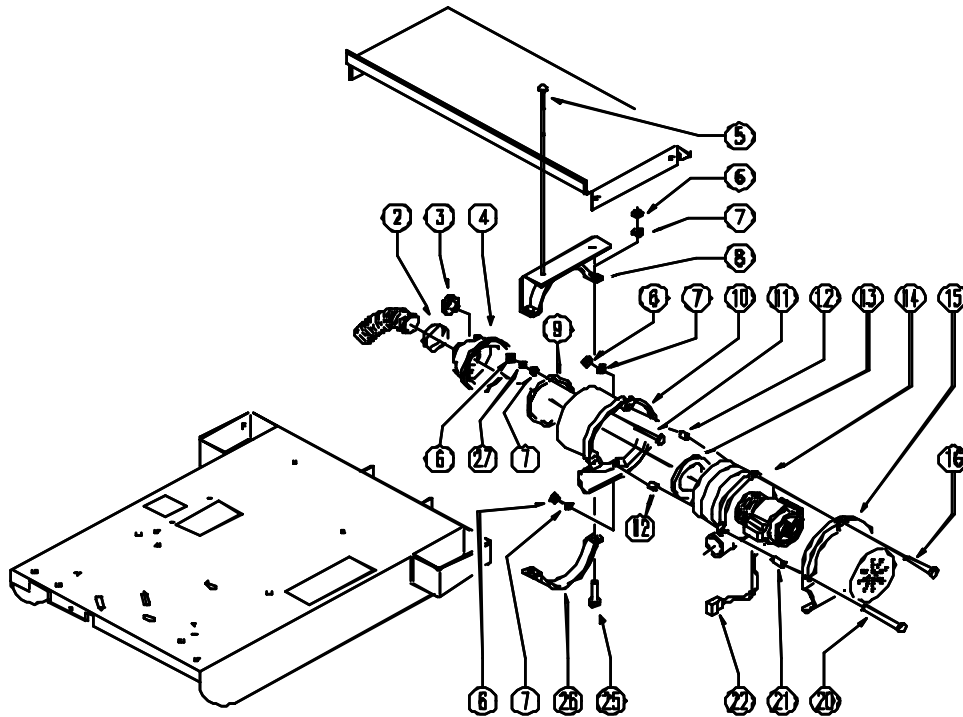

### BOXER-AUTOMATIC SWEEPER/SCRUBBER

POS.	PART #	DESCRIPTION	QTY.
2	SL14063	CLAMP	1
3	SL20006	KNOB (o HANDWHEEL)	2
4	SL17056	LID	1
5	SL04015	SCREW	4
6	SL05058	NUT	7
7	SL06022	WASHER	16
8	SL01017	BRACKET	1
9	SL03516	GASKET	0.45
10	SL17117	SUPPORT	1
11	SL04087	SCREW	2
12	SL07082	BEARING	3
13	SL03515	GASKET	1
14	MP02304-Q	MOTOR	1
15	SL17118	SUPPORT	1
16	SL04056	SCREW	2
20	SL04118	SCREW	1
21	SL07053	BEARING	3
22	SL23454J	WIRING	1

**BOXER-AUTOMATIC SWEEPER/SCRUBBER**

<b>POS.</b>	<b>PART #</b>	<b>DESCRIPTION</b>	<b>QTY.</b>
25	SL04144	SCREW	2
26	SL09143	STRIP / BAND	1
27	SL06023	WASHER	2

## BOXER-AUTOMATIC SWEEPER/SCRUBBER-PL1029

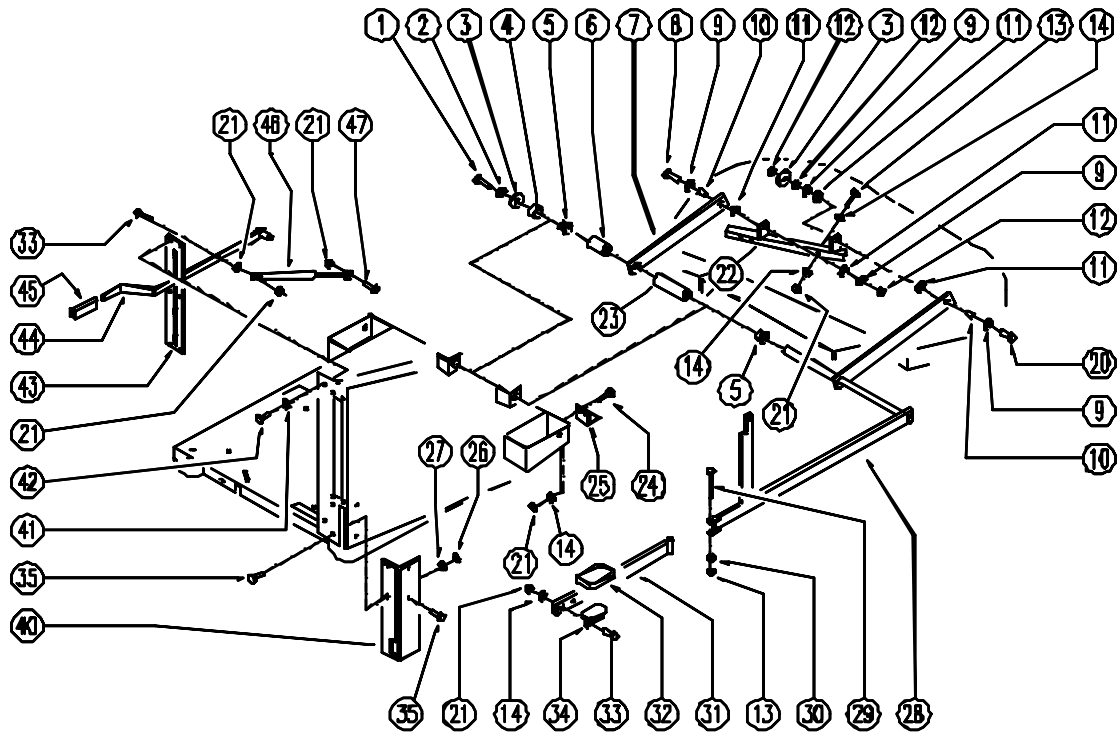

### BOXER-AUTOMATIC SWEEPER/SCRUBBER-PL1029

POS.	PART #	DESCRIPTION	QTY.
1	SL04010	SCREW	1
2	SL06071	WASHER	1
3	SL06050	WASHER	2
4	SL07430	SPACER	1
5	SL12035	BUSHING / BUSH	2
6	SL07485	SPACER	1
7	SL09867	ARM	1
8	SL04003	SCREW	1
9	SL06017	WASHER	4
10	SL07082	SPACER	2
11	SL03209	RUBBER SHIM	4
12	SL05001	NUT	4
13	SL04133	SCREW	4
14	SL06022	WASHER	12
20	SL04143	SCREW	1
21	SL05041	NUT	11
22	SL09981	JOINT / COUPLING	1

**BOXER-AUTOMATIC SWEEPER/SCRUBBER-PL1029**

<b>POS.</b>	<b>PART #</b>	<b>DESCRIPTION</b>	<b>QTY.</b>
23	SL07484	SPACER	1
24	SL04190	SCREW	2
25	SL09871	SUPPORT	1
26	SL05034	NUT	4
27	SL06031	WASHER	4
28	SL09866	LEVER	1
29	SL04156	SCREW	1
30	SL06003	WASHER	1
31	SL09872	ROD	1
32	SL20013	RUBBER SHIM	1
33	SL04136	SCREW	3
34	SL09133	PEDAL	1
35	SL04349	SCREW	4
40	SL09870	HEAD FASTENER	1
41	SL06016	WASHER	6
42	SL04055	SCREW	6
43	SL09869	MASK / TEMPLATE	1
44	SL09868	ROD	1
45	SL20021	HANDGRIP	1
46	SL13119	SPRING	1
47	SL04029	SCREW	1

**BOXER-AUTOMATIC SWEEPER/SCRUBBER-PL1034**

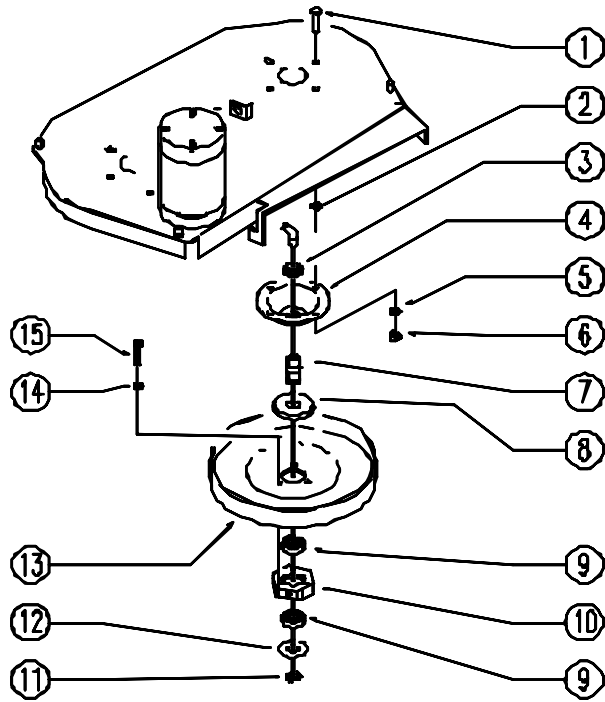

**BOXER-AUTOMATIC SWEEPER/SCRUBBER-PL1034**

POS.	PART #	DESCRIPTION	QTY.
1	SL04271	SCREW	8
2	SL06011	WASHER	8
3	SL05049	NUT	2
4	SL15023	FLANGE	2
5	SL06003	WASHER	8
6	SL05001	NUT	8
7	SL07278	PIN	2
8	SL03259	GUARD	2
9	SL12025	BEARING	4
10	SL14204	HEXAGON	2
11	SL11096	RING	2
12	SL03247	GUARD	2
13	SL10053	PULLEY	2
14	SL06004	WASHER	6
15	SL04119	SCREW	6

**BOXER-AUTOMATIC SWEEPER/SCRUBBER-PL1033**

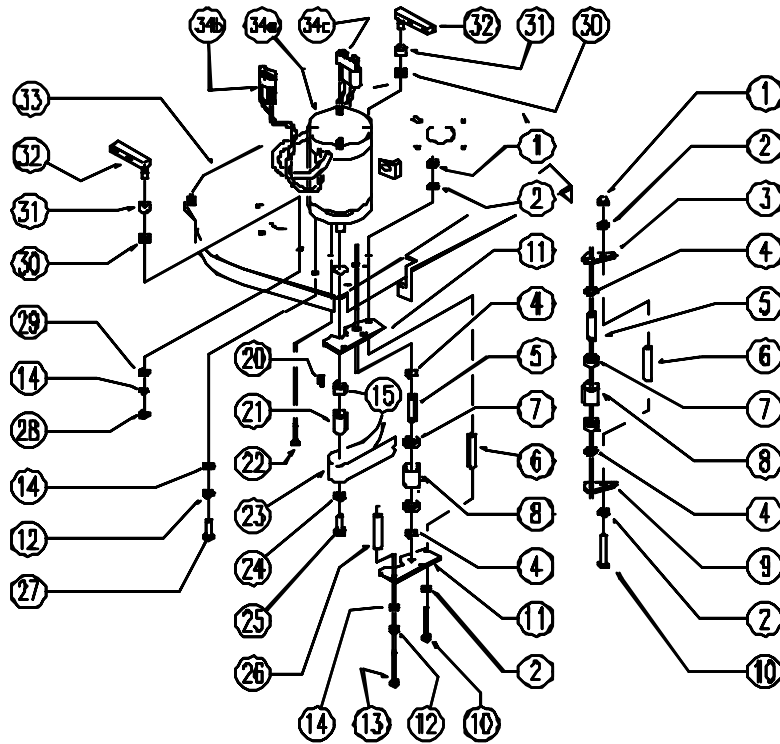

**BOXER-AUTOMATIC SWEEPER/SCRUBBER-PL1033**

POS.	PART #	DESCRIPTION	QTY.
1	SL05011	NUT	3
2	SL06004	WASHER	6
3	SL09855	PLATE	1
4	SL11095	RING	4
5	SL11041	PIN	2
6	SL07143	SPACER	3
7	SL12003	BEARING	4
8	SL10045	PULLEY	2
9	SL09854	PLATE	1
10	SL04326	SCREW	3
11	SL09622	PLATE	2
12	SL06002	WASHER	3
13	SL04049	SCREW	2
14	SL06003	WASHER	5
15	SL10068	SPACER	1
20	SL11010	TONGUE	1
21	SL07222	PULLEY	1

**BOXER-AUTOMATIC SWEEPER/SCRUBBER-PL1033**

<b>POS.</b>	<b>PART #</b>	<b>DESCRIPTION</b>	<b>QTY.</b>
22	SL04283	SCREW	1
23	SL16029	BELT	1
24	SL07166	WASHER	1
25	SL04096	SCREW	1
26	SL07234	SPACER	2
27	SL04083	SCREW	1
28	SL05001	NUT	2
29	SL06064	WASHER	2
30	SL06062	WASHER	2
31	SL03209	RUBBER	2
32	SL09629	BRACKET	2
33	SL09884	PLATE	1
34a	SL02113	MOTOR	1
34b	SL23527	CONNECTOR	1
34c	SL23010	CONNECTOR	1
34d	SL02113-1	MOTOR COAL	2

## BOXER-AUTOMATIC SWEEPER/SCRUBBER-PL1032

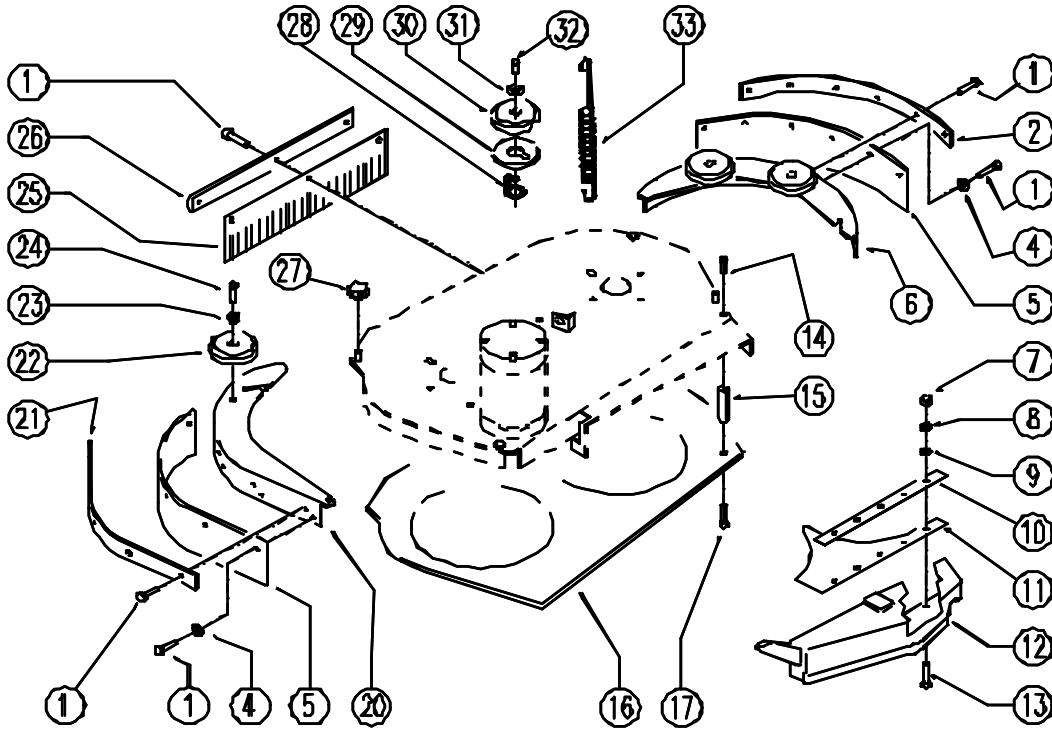

### BOXER-AUTOMATIC SWEEPER/SCRUBBER-PL1032

POS.	PART #	DESCRIPTION	QTY.
1	SL04065	SCREW	23
2	SL03423	FLAP PRESS	1
4	SL06031	WASHER	10
5	SL03422	FLAP	2
6	SL09883	COVER	1
7	SL05044	NUT	5
8	SL06033	WASHER	5
9	SL06032	WASHER	5
10	SL21133	LAMINATION	1
11	SL17375	DUSTPAN	1
12	SL17330	CASE	1
13	SL04364	SCREW	5
14	SL04006	SCREW	8
15	SL14205	SPACER	7
16	SL03425	GUARD	1
17	SL04342	SCREW	8

**BOXER-AUTOMATIC SWEEPER/SCRUBBER-PL1032**

<b>POS.</b>	<b>PART #</b>	<b>DESCRIPTION</b>	<b>QTY.</b>
20	SL09882	COVER	1
21	SL03421	FLAP PRESS	1
22	SL08040	WHEEL	3
23	SL07390	BUSHING	3
24	SL04167	SCREW	3
25	SL03424	FLAP	1
26	SL03426	FLAP PRESS	1
27	SL20002	HANDLE	2
28	SL09965	SUPPORT	2
29	SL03513	GASKET	2
30	SL08048	SPACER	2
31	SL06025	WASHER	2
32	SL04101	SCREW	3
33	SL13064	SPRING	1

## BOXER-AUTOMATIC SWEEPER/SCRUBBER-PL1035

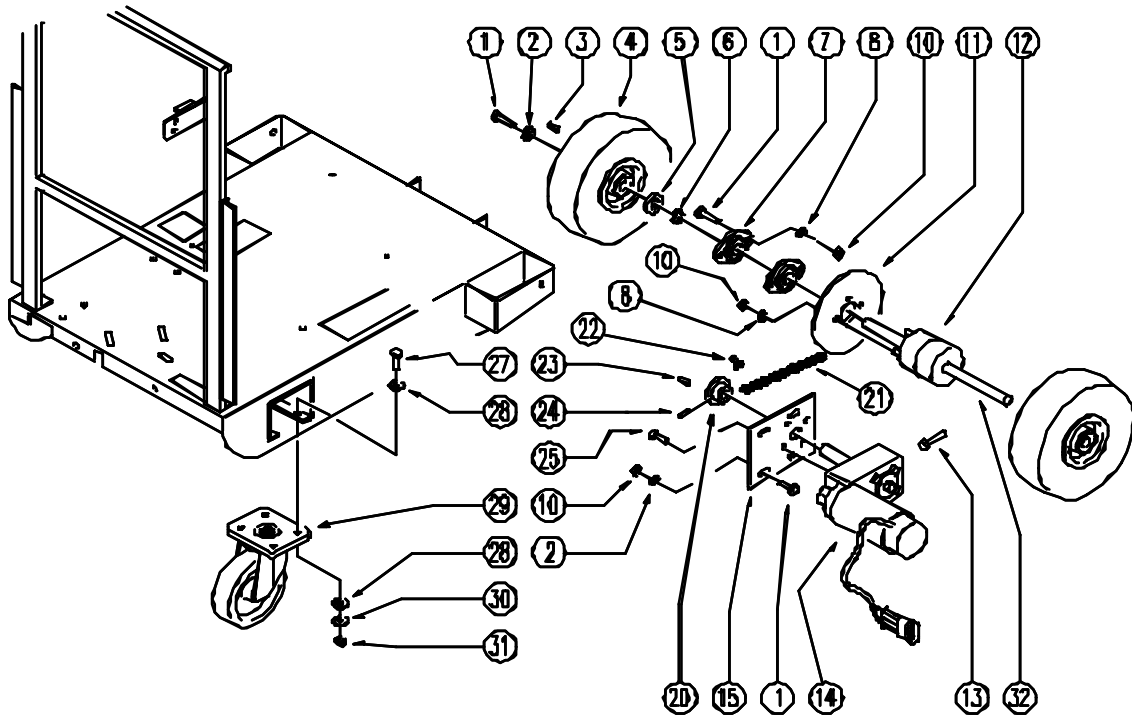

### BOXER-AUTOMATIC SWEEPER/SCRUBBER-PL1035

POS.	PART #	DESCRIPTION	QTY.
1	SL04134	SCREW	14
2	SL06025	WASHER	8
3	SL11010	TANG / TONGUE	2
4	SL08045	WHEEL / SMALL WHEEL	2
5	SL07428	BEARING	2
6	SL11094	RING	2
7	SL12031	SUPPORT	4
8	SL06041	WASHER	8
10	SL05039	NUT	16
11	SL10019	CROWN	1
12	9224710	DIFFERENTIAL	1
13	SL04155	SCREW	1
14	SL02237	MOTOR	1
15	SL09873	PLATE	1
20	SL10069	PINION	1
21	SL16030	CHAIN	1
22	SL16027	GRID	1
23	SL11002	TANG / TONGUE	1

**BOXER-AUTOMATIC SWEEPER/SCRUBBER-PL1035**

<b>POS.</b>	<b>PART #</b>	<b>DESCRIPTION</b>	<b>QTY.</b>
24	SL11048	SPLIT PIN	1
25	SL04135	SCREW	4
27	SL04166	SCREW	8
28	SL06101	WASHER	16
29	SL08007	WHEEL / SMALL WHEEL	2
30	SL06102	WASHER	8
31	SL05050	NUT	8
32	SL10029	AXLE SHAFT	1

## BOXER-AUTOMATIC SWEEPER/SCRUBBER-PL1025

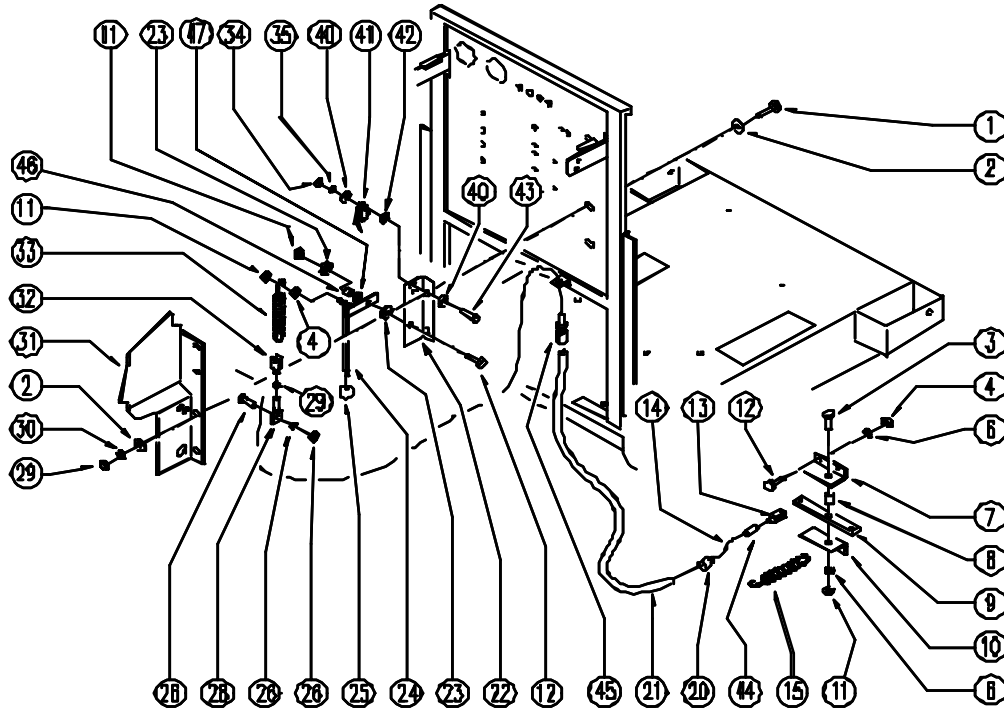

### BOXER-AUTOMATIC SWEEPER/SCRUBBER-PL1025

POS.	PART #	DESCRIPTION	QTY.
1	SL04190	SCREW	2
2	SL06015	WASHER	2
3	SL04004	SCREW	1
4	SL05041	NUT	5
6	SL06039	WASHER	5
7	SL09199	SUPPORT	1
8	SL07063	BUSHING / BUSH	1
9	SL09176	INSERT	1
10	SL09177	SUPPORT	1
11	SL05001	NUT	3
12	SL04002	SCREW	5
13	SL22008	FORK	1
14	SL14095	CABLE	1
15	SL13013	SPRING	1
20	SL07231	BUSHING / BUSH	1
21	SL14052	SHEATH	1
22	SL09175	SUPPORT	1
23	SL06018	WASHER	2

**BOXER-AUTOMATIC SWEEPER/SCRUBBER-PL1025**

<b>POS.</b>	<b>PART #</b>	<b>DESCRIPTION</b>	<b>QTY.</b>
24	SL09174	LEVER	1
25	SL20015	KNOB (o HANDWHEEL)	1
26	SL14031	CLAMP	1
28	SL09128	PLAQUE	1
29	SL05005	NUT	3
30	SL06001	WASHER	2
31	SL17087	GUARD	1
32	SL22007	FORK	1
33	SL13011	SPRING	1
34	SL05009	NUT	2
35	SL06024	WASHER	2
40	SL06009	WASHER	4
41	SL23109	BRAKE MICROSWITCH	1
42	SL05012	NUT	2
43	SL04031	SCREW	2
44	SL07064	SPLIT PIN	1
45	SL14032	REGISTER	1
46	SL07410	BUSHING / BUSH	1
47	SL06040	WASHER	1

## BOXER-AUTOMATIC SWEEPER/SCRUBBER-PL1030

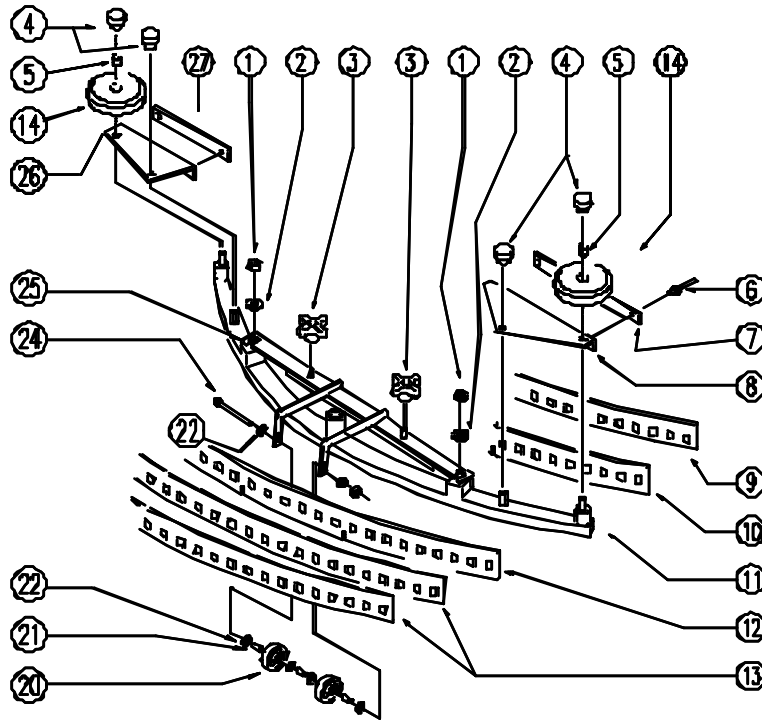

### BOXER-AUTOMATIC SWEEPER/SCRUBBER-PL1030

POS.	PART #	DESCRIPTION	QTY.
1	SL05039	NUT	2
2	SL06017	WASHER	2
3	SL20004	KNOB (o HANDWHEEL)	2
4	SL20018	KNOB (o HANDWHEEL)	4
5	SL07065	BEARING	2
6	SL14238	RIVET	4
7	SL03287	CLAMP	1
8	SL09765	BUMPER	1
9	SL03289	RUBBER SHIM	1
10	SL03257	BLADE	1
11	SL01024	BODY	1
12	SL03488	BLADE	1
13	SL03279	REINFORCEMENT	2
14	SL08040	WHEEL / SMALL WHEEL	2
20	SL08015	WHEEL / SMALL WHEEL	2
21	SL07165	BEARING	3
22	SL06022	WASHER	6

**BOXER-AUTOMATIC SWEEPER/SCRUBBER-PL1030**

<b>POS.</b>	<b>PART #</b>	<b>DESCRIPTION</b>	<b>QTY.</b>
23	SL05011	NUT	1
24	SL04199	SCREW	1
25	SL09782	SUPPORT	1
26	SL09733	BUMPER	1
27	SL03286	STRIP / BAND	1

## BOXER-AUTOMATIC SWEEPER/SCRUBBER-PL1031

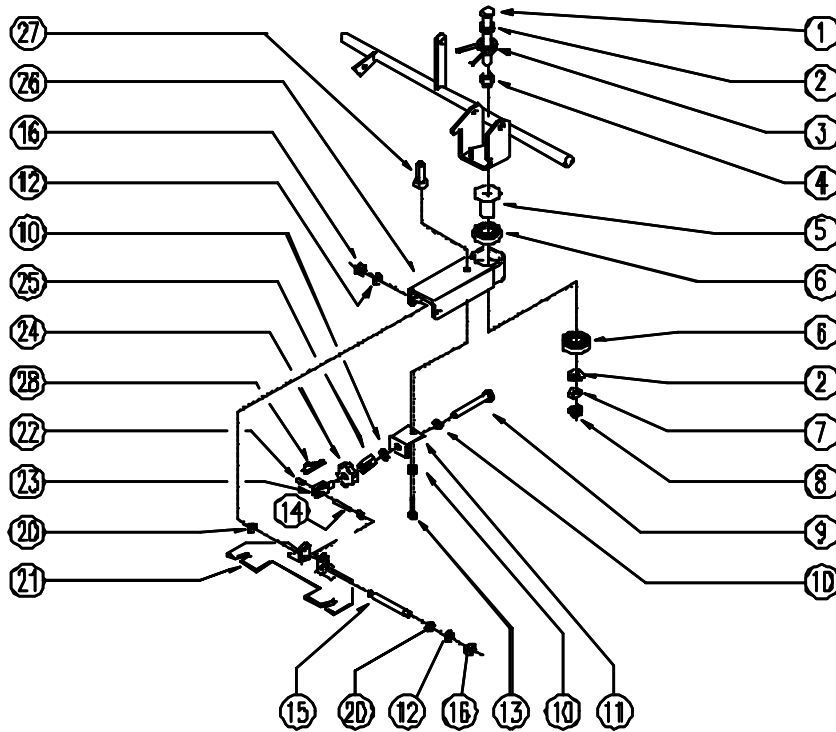

### BOXER-AUTOMATIC SWEEPER/SCRUBBER-PL1031

POS.	PART #	DESCRIPTION	QTY.
1	SL04116	SCREW	1
2	SL06050	WASHER	2
3	SL13100	SPRING	1
4	SL07361	BUSHING / BUSH	1
5	SL07362	PIN	1
6	SL12025	BEARING	2
7	SL05050	NUT	1
8	SL05032	NUT	1
9	SL04156	SCREW	1
10	SL06041	WASHER	3
11	SL09797	SUPPORT	1
12	SL06022	WASHER	2
13	SL04164	SCREW	1
14	SL11050	PIN / PLUG	1
15	SL07400	PIN	1
16	SL05041	NUT	2
20	SL06064	WASHER	2

**BOXER-AUTOMATIC SWEEPER/SCRUBBER-PL1031**

<b>POS.</b>	<b>PART #</b>	<b>DESCRIPTION</b>	<b>QTY.</b>
21	SL09956	BRACKET	1
22	SL07472	BEARING	2
23	SL22008	FORK	1
24	SL06100	KNOB (o HANDWHEEL)	1
25	SL05081	NUT	2
26	SL09798	ARM	1
27	SL07253	BEARING	1
28	SL11118	SPLIT PIN	1

## BOXER-AUTOMATIC SWEEPER/SCRUBBER-PL1028

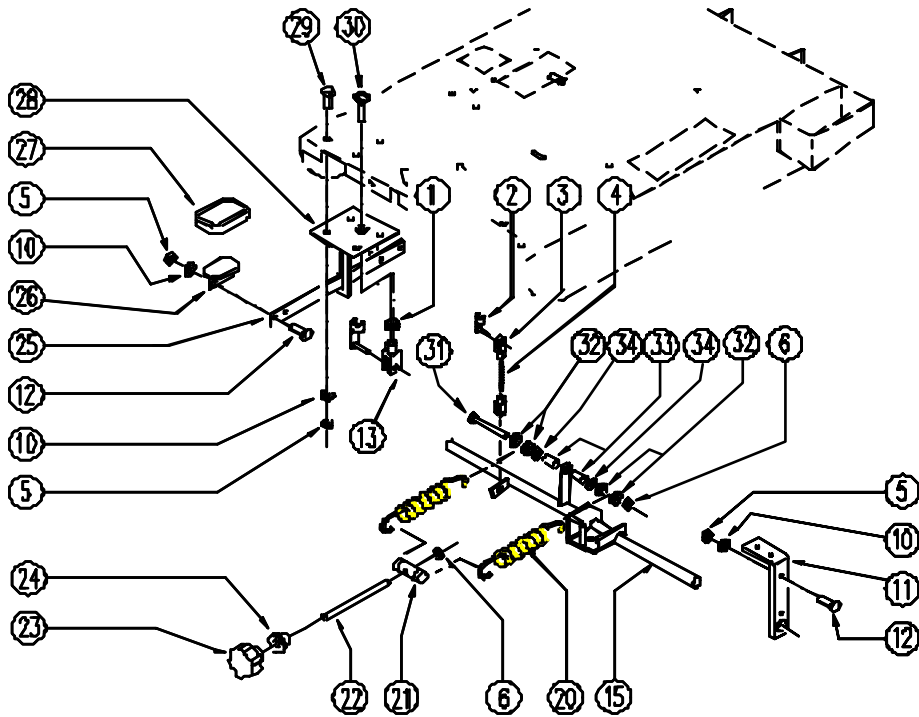

### BOXER-AUTOMATIC SWEEPER/SCRUBBER-PL1028

POS.	PART #	DESCRIPTION	QTY.
1	SL06101	WASHER	1
2	SL22010	BRACKET	2
3	SL22008	FORK	2
4	SL11008	SPLIT PIN	1
5	SL05058	NUT	10
6	SL05039	NUT	2
10	SL06004	WASHER	10
11	SL09876	SUPPORT	1
12	SL04048	SCREW	6
13	SL22006	FORK	1
15	SL09875	SHAFT	1
20	SL13078	SPRING	2
21	SL09537	HOOKING / COUPLING	1
22	SL07476	BAR	1
23	SL20002	KNOB (o HANDWHEEL)	1
24	SL07050	BUSHING / BUSH	1
25	SL09983	LEVER	1
26	SL09133	PEDAL	1

**BOXER-AUTOMATIC SWEEPER/SCRUBBER-PL1028**

<b>POS.</b>	<b>PART #</b>	<b>DESCRIPTION</b>	<b>QTY.</b>
27	SL20013	RUBBER SHIM	1
28	SL09982	SUPPORT	1
29	SL04190	SCREW	4
30	SL04366	SCREW	1
31	SL04201	SCREW	1
32	SL06025	WASHER	4
33	SL07082	SPACER	2
34	SL05048	NUT	2

## BOXER-AUTOMATIC SWEEPER/SCRUBBER-PL1023

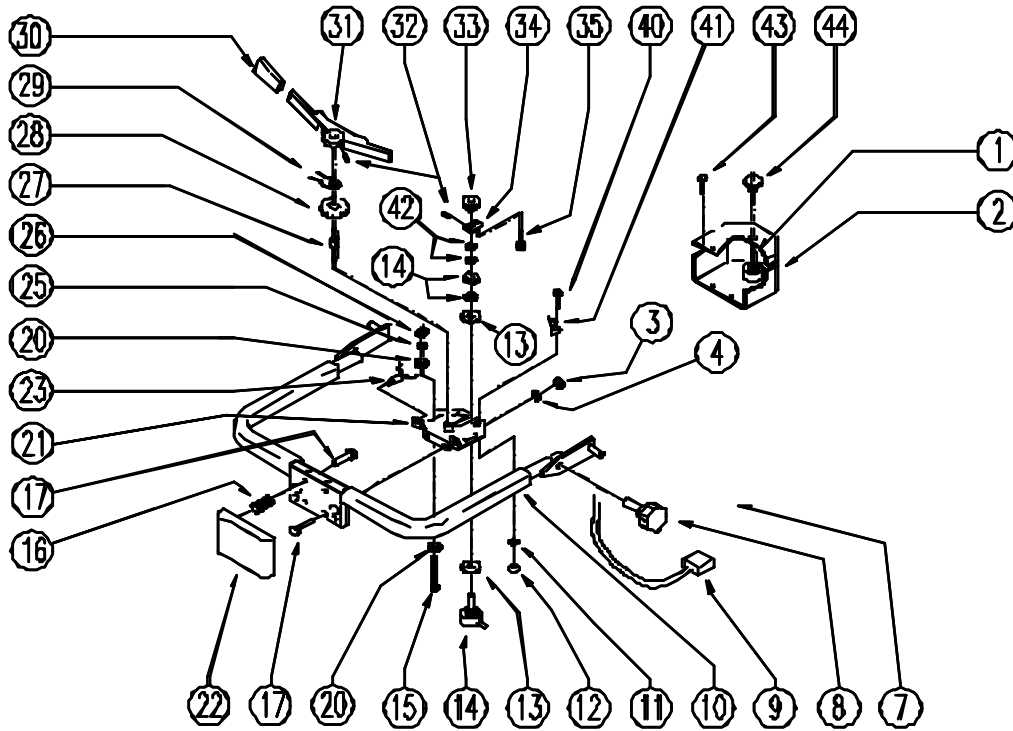

### BOXER-AUTOMATIC SWEEPER/SCRUBBER-PL1023

POS.	PART #	DESCRIPTION	QTY.
1	SL23664	POTENTIOMETER	1
2	SL17080	LID	1
3	SL05006	NUT	2
4	SL06020	WASHER	2
8	SL20012	KNOB (ø HANDWHEEL)	2
9	GR23357	WIRING	1
10	SL09181-1	HANDGRIP	1
11	SL06009	WASHER	4
12	SL05031	NUT	4
13	SL06011	WASHER	2
14	SL23357	POTENTIOMETER	1
15	SL04197	SCREW	1
16	SL13022	SPRING	4
17	SL04081	SCREW	6
20	SL06031	WASHER	2
21	SL09201	TERMINAL BOARD	1
22	SL01019	BLOCK / LOCK	1

**BOXER-AUTOMATIC SWEEPER/SCRUBBER-PL1023**

<b>POS.</b>	<b>PART #</b>	<b>DESCRIPTION</b>	<b>QTY.</b>
23	SL23122	MICROBUTTON	2
25	SL06033	WASHER	1
26	SL05012	NUT	1
27	SL07073	PIN	1
28	SL14057	WHEEL / SMALL WHEEL	1
29	SL13023	SPRING	1
30	SL20054	HANDGRIP	2
31	SL09183	LEVER	1
32	SL11023	SCREW	2
33	SL14056	WHEEL / SMALL WHEEL	1
34	SL09182	CAM	1
35	SL04033	SCREW	1
40	SL04086	SCREW	4
41	SL23120	MICROSWITCH	2
42	SL06039	WASHER	2
43	SL04079	SCREW	4
44	SL23821	HANDGRIP	1

## BOXER-AUTOMATIC SWEEPER/SCRUBBER-PL1036

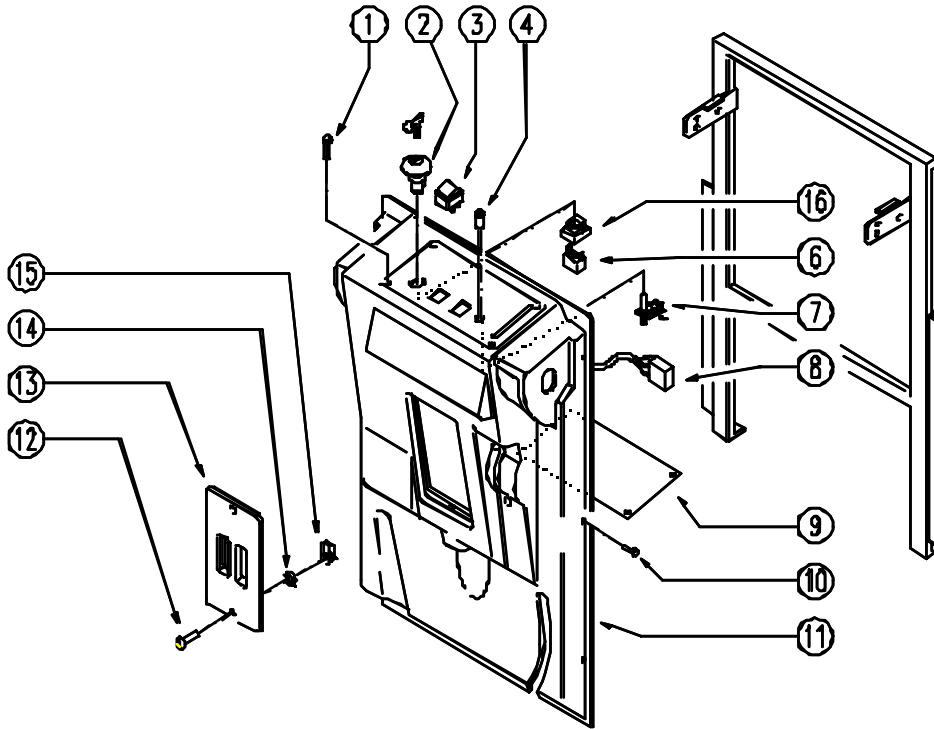

### BOXER-AUTOMATIC SWEEPER/SCRUBBER-PL1036

POS.	PART #	DESCRIPTION	QTY.
1	SL04079	SCREW	4
2	SL23954	MUSHROOM	1
3	SL23183	SWITCH	2
4	SL23031-1	(RETRO)REFLECTOR / REFLEX REFLECTOR	1
6	SL23956	CONNECTION	1
7	SL23039	GEARCASE / BOARD	14
8	GR23614	WIRING	1
9	SL09919	REINFORCEMENT	1
10	SL04006	SCREW	6
11	SL17548	CONTROL PANEL	1
12	SL04039	SCREW	2
13	SL17079	LID	1
14	SL03116	GASKET	2
15	SL05030	NUT	2
16	SL23955	BASE	1

## BOXER-AUTOMATIC SWEEPER/SCRUBBER-PL1024

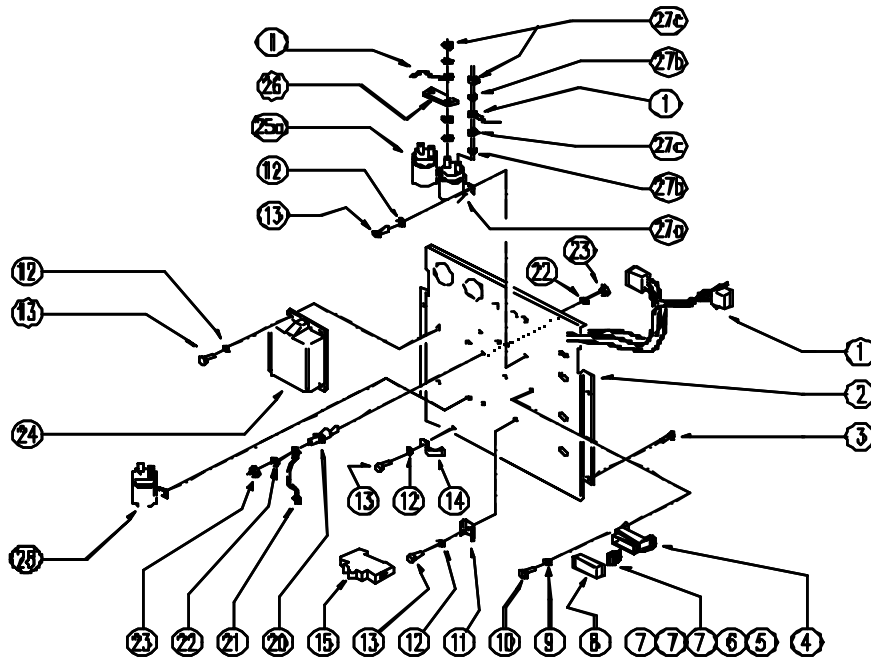

### BOXER-AUTOMATIC SWEEPER/SCRUBBER-PL1024

POS.	PART #	DESCRIPTION	QTY.
1	GR23612	WIRING	1
2	SL09885	PLATE	1
3	SL04079	SCREW	4
4	SL23210	FUSE CARRIER	1
5	SL23892	FUSE	1
6	SL23147	FUSE	1
7	SL23144	FUSE	3
8	SL23893-2	LID	1
9	SL06016	WASHER	2
10	SL04119	SCREW	2
11	SL09250	SUPPORT	1
12	SL06020	WASHER	8
13	SL04081	SCREW	8
14	SL23946	U BOLT	1
15	SL23180	MAGNETOTHERMAL DEVICE	1
20	SL23103	INSULATOR	2
21	SL23611	SHUNT	1
22	SL09174	WASHER	4
23	SL05004	NUT	4

**BOXER-AUTOMATIC SWEEPER/SCRUBBER-PL1024**

<b>POS.</b>	<b>PART #</b>	<b>DESCRIPTION</b>	<b>QTY.</b>
24	SL23610	GEARCASE / BOARD	1
25a	SL23371	REMOTE CONTROL SWITCH	1
26	SL23111	BRIDGE / JUMPER	1
27a	SL23034	REMOTE CONTROL SWITCH	1
27b	SL09174	WASHER	4
27c	SL05004	NUT	4
28	SL23033	REMOTE CONTROL REVERSER	1

## BOXER-AUTOMATIC SWEEPER/SCRUBBER-PL1026

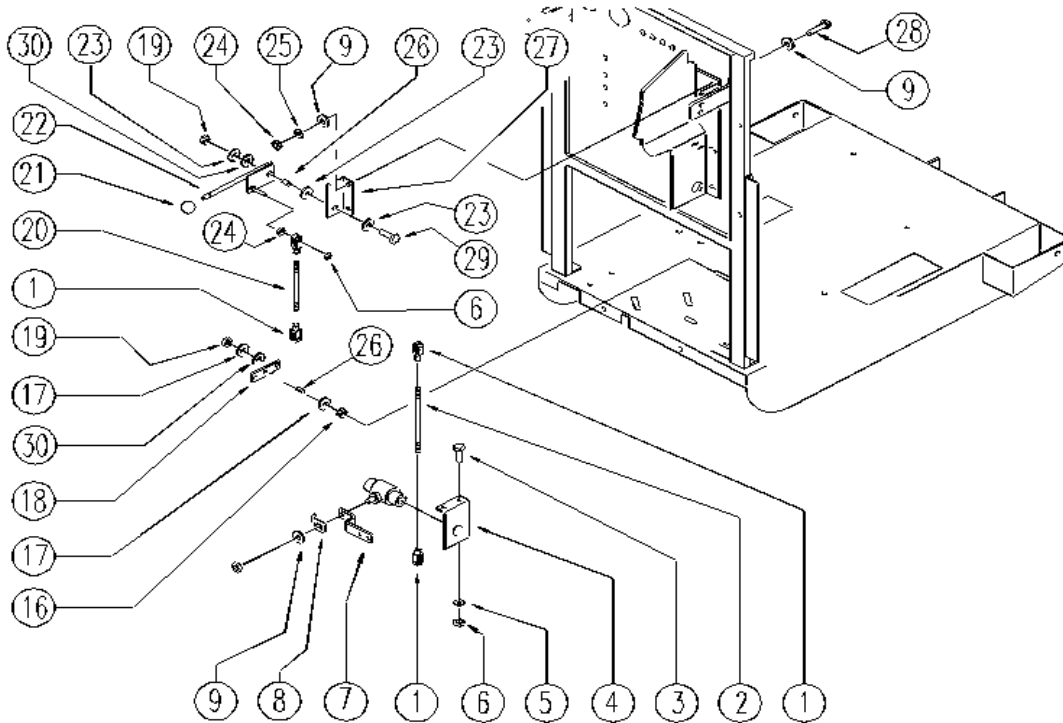

## BOXER-AUTOMATIC SWEEPER/SCRUBBER-PL1026

POS.	PART #	DESCRIPTION	QTY.
1	SL22007	FORK	4
2	SL09459	TIE ROD	1
3	SL04010	SCREW	2
4	SL09172	SUPPORT	1
5	SL06022	WASHER	1
6	SL05011	NUT	3
7	SL09986	LEVER	1
8	SL09918	TAP CASING	1
9	SL06011	WASHER	1
16	SL05004	NUT	1
17	SL06018	WASHER	2
18	SL09458	TRANSMISSION	1
19	SL05001	NUT	3
20	SL09169	TIE ROD	1
21	SL20015	KNOB (o HANDWHEEL)	1
22	SL09167	LEVER	1
23	SL06003	WASHER	4
24	SL05017	NUT	2

**BOXER-AUTOMATIC SWEEPER/SCRUBBER-PL1026**

<b>POS.</b>	<b>PART #</b>	<b>DESCRIPTION</b>	<b>QTY.</b>
25	SL06001	WASHER	2
26	SL07410	BUSHING / BUSH	2
27	SL09168	SUPPORT	1
28	SL04145	SCREW	1
29	SL04190	SCREW	2
30	SL06040	WASHER	2

## BOXER - AUTOMATIC SWEEPER/SCRUBBER-p11380

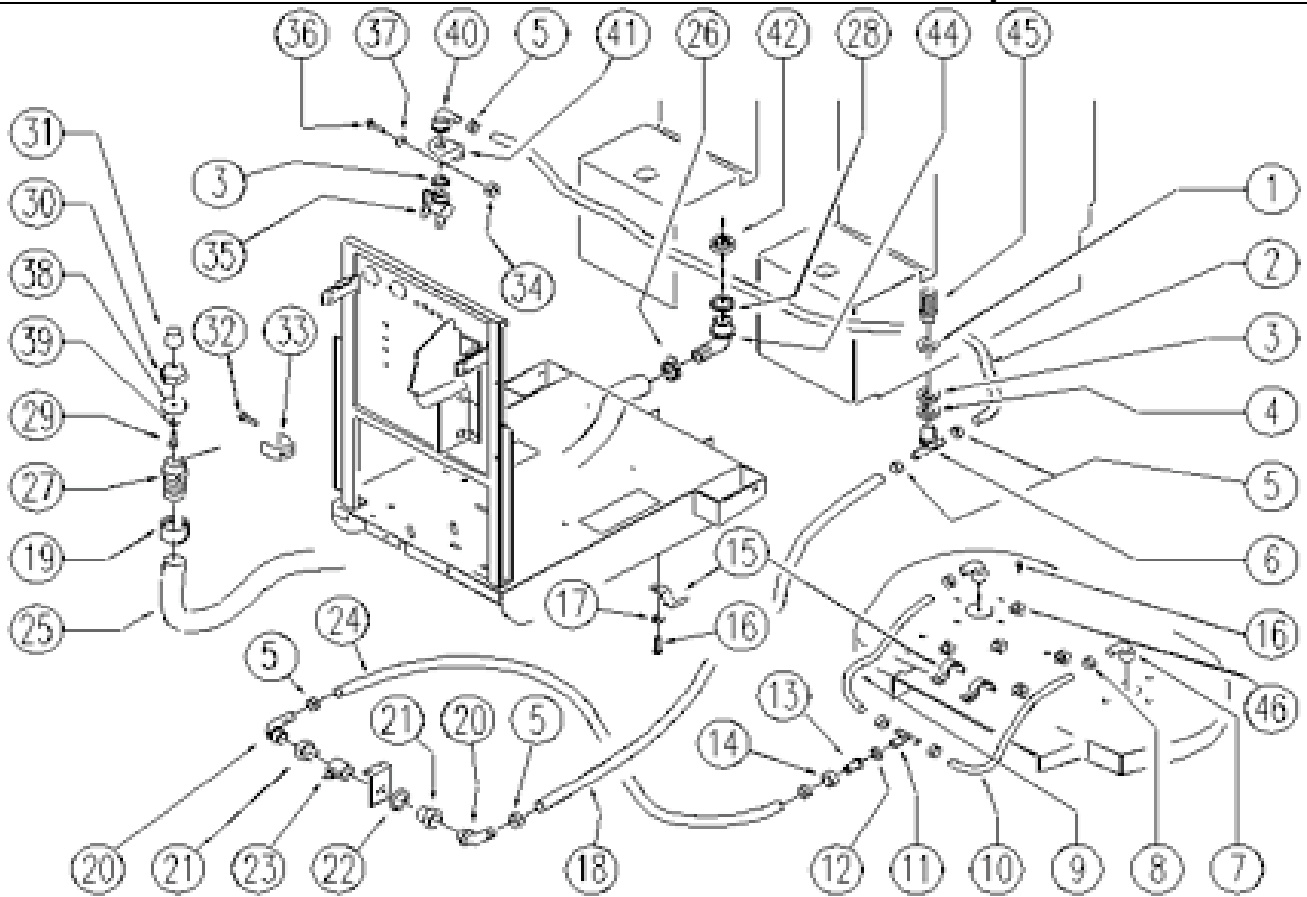

### BOXER - AUTOMATIC SWEEPER/SCRUBBER-p11380

POS.	PART #	DESCRIPTION	QTY.
1	SL05076	NUT	1
2	SL19303	HOSE	1
3	SL03415	GASKET	2
4	SL06096	WASHER	1
5	SL14007	CLAMP	5
6	SL18335-1	UNION / CONNECTOR	1
7	SL18341	UNION / CONNECTOR	2
8	SL14036	CLAMP	4
9	SL19311	HOSE	1
10	SL19287	HOSE	1
11	SL18339	UNION / CONNECTOR	1
12	SL03466	GASKET	1
13	SL18360	UNION / CONNECTOR	1
14	SL18359	NUT	1
15	SL23108	CLIP	3

**BOXER - AUTOMATIC SWEEPER/SCRUBBER-pl1380**

<b>POS.</b>	<b>PART #</b>	<b>DESCRIPTION</b>	<b>QTY.</b>
16	SL04079	SCREW	8
17	SL06031	WASHER	3
18	SL19302	HOSE	1
19	SL07470	NUT	1
20	SL18340	UNION / CONNECTOR	2
21	SL18186	REDUCTION	2
22	SL07495	BEARING	1
23	SL18013	TAP	1
24	SL19282	HOSE	1
25	SL19271	HOSE	1
26	SL14079	CLAMP	1
27	SL18377	HOSE HOLDER	1
28	SL03459	GASKET	1
29	SL04342	SCREW	1
30	SL18378	CAP	1
31	SL07469	CAP	1
32	SL04079	SCREW	2
33	SL13045	DUCT LOCK	1
34	SL05043	NUT	2
35	SL18338	TAP	1
36	SL04152	SCREW	2
37	SL06034	WASHER	2
38	SL03489	GASKET	1
39	SL06034	WASHER	1
40	SL18337	UNION / CONNECTOR	1
41	SL09874	SUPPORT	1
42	SL05080	NUT	1
44	SL18354	UNION / CONNECTOR	1
45	SL18019	FILTER CARTRIDGE	1
46	SL14338	CLIP	5

## BOXER-AUTOMATIC SWEEPER/SCRUBBER-pl 1022

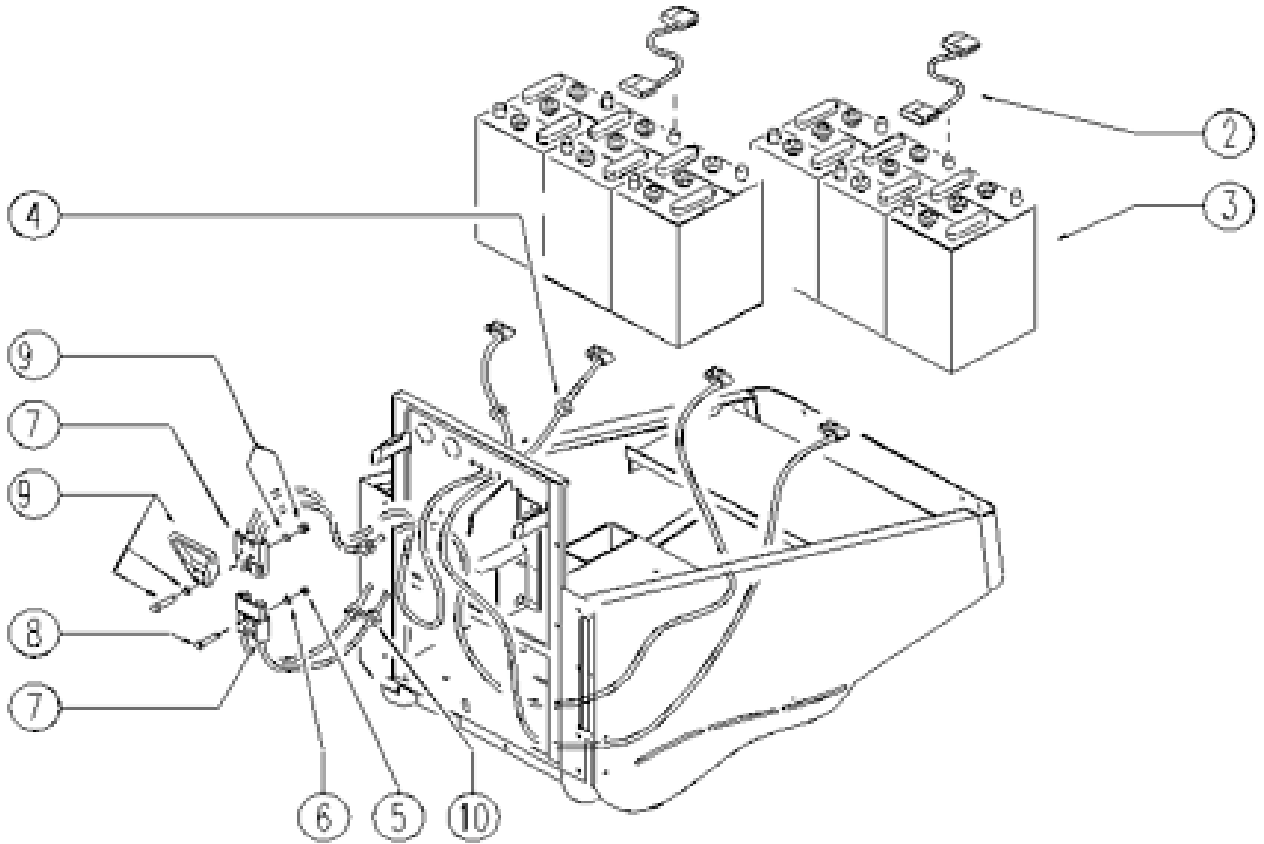

### BOXER-AUTOMATIC SWEEPER/SCRUBBER-pl1022

POS.	PART #	DESCRIPTION	QTY.
2	SL53023	BRIDGE / JUMPER	4
3	AL03005	BATTERY	6
4	SL23050	FAIRLEAD	2
5	SL05058	NUT	2
6	SL06004	WASHER	2
7	SL23184	TAP / OUTLET	2
8	SL04056	SCREW	1
9	SL09294	HANDLE	1
10	SL23713	FAIRLEAD	4

## BOXER-AUTOMATIC SWEEPER/SCRUBBER - pl1027

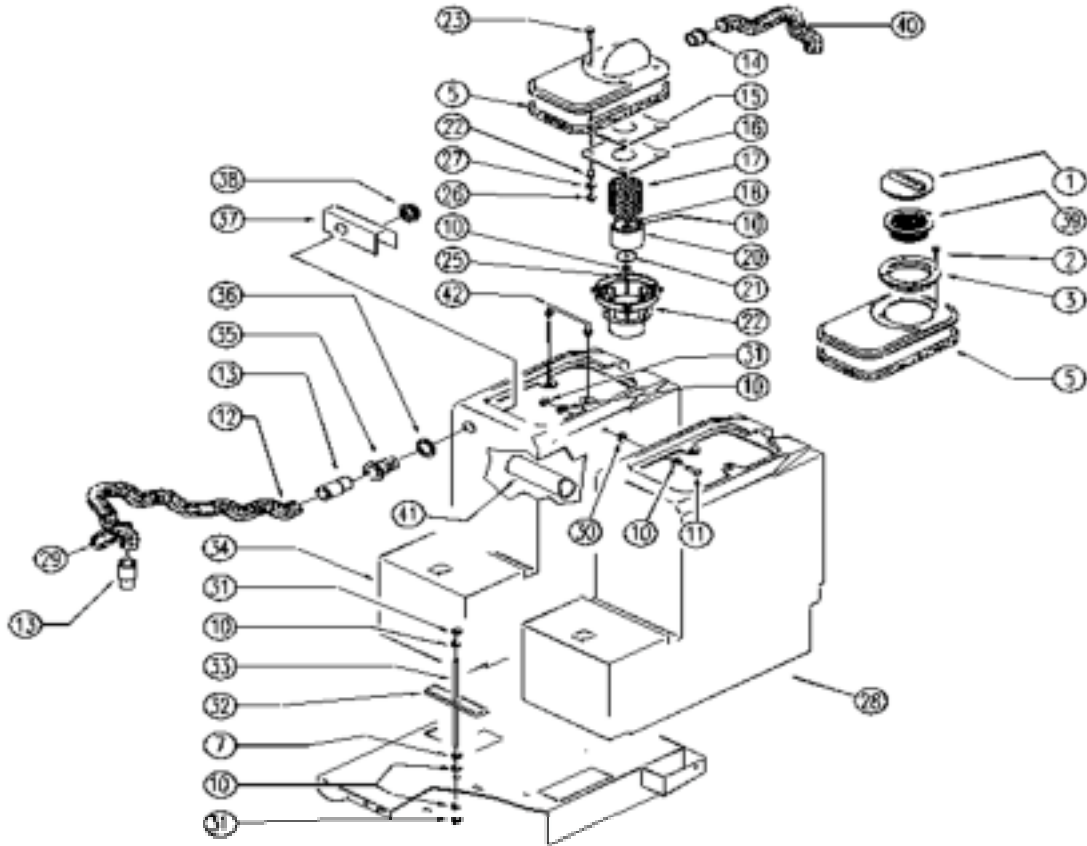

## BOXER-AUTOMATIC SWEEPER/SCRUBBER - pl1027

POS.	PART #	DESCRIPTION	QTY.
1	SL14324	CAP	1
2	SL04342	SCREW	4
3	SL14325	NUT	1
5	SL03420	GASKET	2
7	SL05017	NUT	1
10	SL06039	WASHER	7
11	SL04087	SCREW	1
12	SL19264	HOSE	1
13	SL14003	SLEEVE	2
14	SL07178	BUSHING / BUSH	1
15	SL03430	GASKET	1
16	SL17527	FLOAT LIMIT SWITCH	1
17	SL18342	FILTER	1
18	SL05074	NUT	1
20	SL17590	FLOAT	1

**BOXER-AUTOMATIC SWEEPER/SCRUBBER - pl1027**

<b>POS.</b>	<b>PART #</b>	<b>DESCRIPTION</b>	<b>QTY.</b>
21	SL03346	GASKET	1
22	RA02823	SUPPORT	1
23	SL04361	SCREW	4
25	SL04342	SCREW	1
26	SL05016	NUT	4
27	SL06034	WASHER	4
28	SL17517	TANK	1
29	SL03437	PLAQUE	1
30	SL03083	RUBBER SHIM	1
31	SL05041	NUT	3
32	SL09932	PLATE	1
33	SL04352	PIN	1
34	SL17518	TANK	1
35	SL18355	SUCTION OPENING	1
36	SL03416	GASKET	1
37	SL09863	BAFFLE PLATE	1
38	SL14327	NUT	1
39	SL18356	FILTER	1
40	SL19050	HOSE	1
41	SL07511	CROSS	1
42	SL07482	REINFORCEMENT	1

## BOXER-AUTOMATIC SWEEPER/SCRUBBER-pl1083

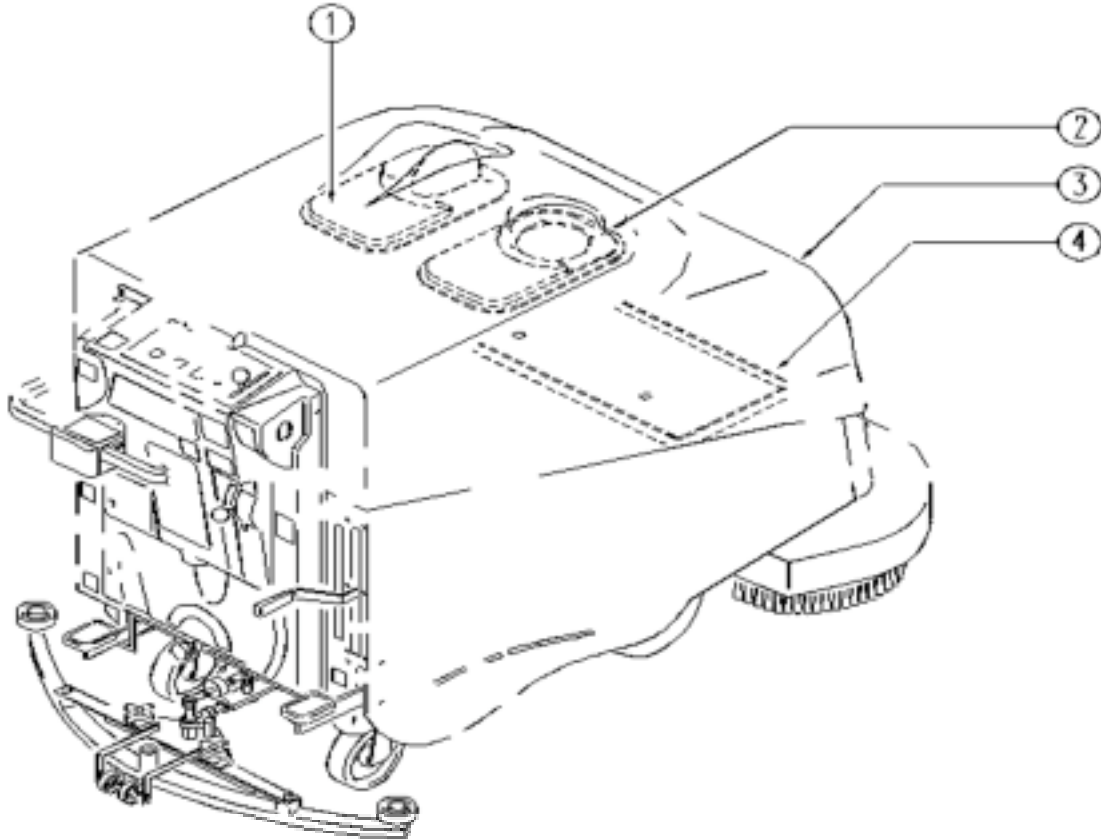

### BOXER-AUTOMATIC SWEEPER/SCRUBBER-pl1083

POS.	PART #	DESCRIPTION	QTY.
1	SL17514	GREEN LID	1
1	SL17514AS	GREY LID	1
1	SL17514BE	RED LID	1
2	SL17515	GREEN LID	1
2	SL17515AS	GREY LID	1
2	SL17515BE	RED LID	1
3	SL17511	GREEN HOOD	1
3	SL17511AS	GREY HOOD	1
3	SL17511BE	RED HOOD	1
4	SL17512	GREEN PLATE	2
4	SL17512AS	GREY PLATE	2
4	SL17512BE	RED PLATE	2

## BOXER-AUTOMATIC SWEEPER/SCRUBBER-p11084N

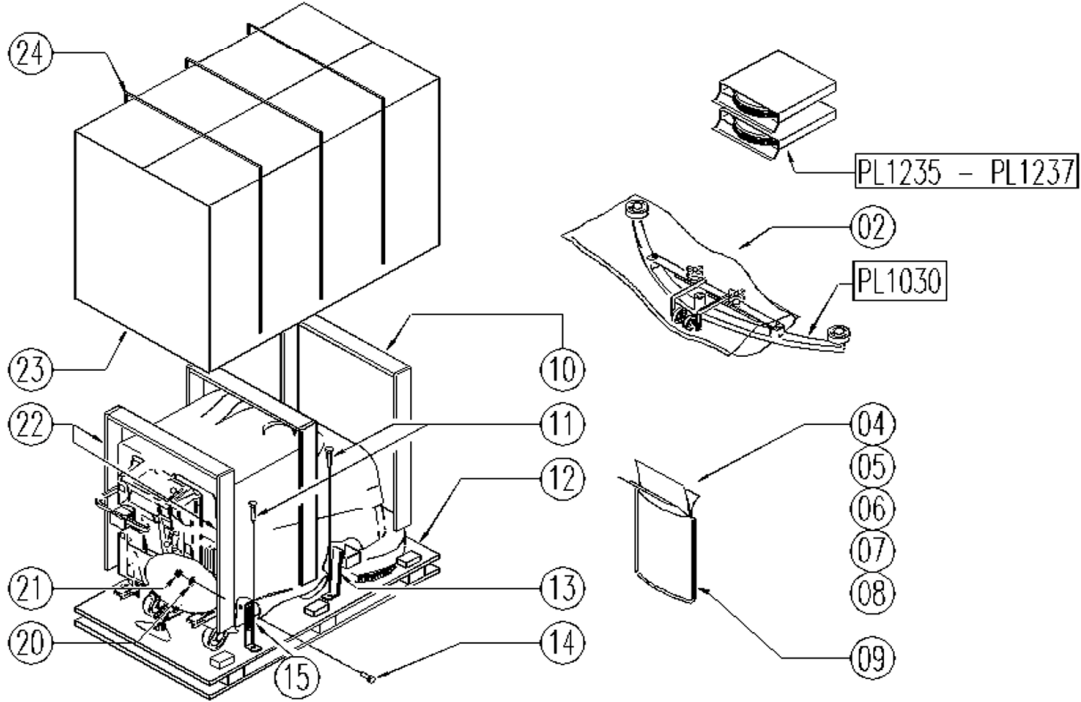

### BOXER-AUTOMATIC SWEEPER/SCRUBBER-p11084N

POS.	PART #	DESCRIPTION	QTY.
2	MP14302	TUBULAR	1.5
4	SL26029	ENVELOPE	1
5	SL25303	SHEET	1
6	SL25400-3	WARRANTY COUPON	1
7	SL25400-5	COUPON	1
8	SL25400-8	EC CERTIFICATION	1
9	SL25917N-1	MANUAL	1
10	SL26086	LATH / SPLINE	3
11	SL04249	SCREW	4
12	SL26106	PALLET	1
13	SL09704	BRACKET	2
14	SL04001	SCREW	2
15	SL09241	BRACKET	2
20	SL06087	WASHER	2
21	SL05001	NUT	2
22	SL26108	LATH / SPLINE	6
23	SL26089N	CARDBOARD	1
24	MP14300	STRAP	9

**BOXER-AUTOMATIC SWEEPER/SCRUBBER-pl1237**

POLYPROPYLENE- NYLON - NYLON  
 NYLON - NYLON

①



POLYSHING - POLIERBURSTERN  
 SORGHO - FIBRA - BASSINA

②



TYNEX - TYNEX - TYNEX  
 TYNEX - TYNEX

③

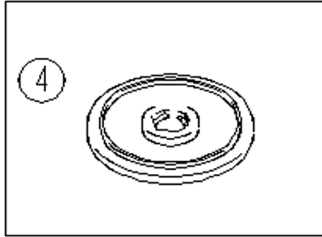
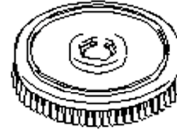

BLACK - SCHWARZ - NOIR  
 PAD - NERO

⑤

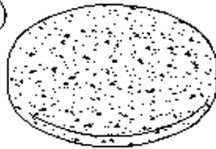

GREEN - GRUEN- VERT  
 VERDE - VERDE

⑥

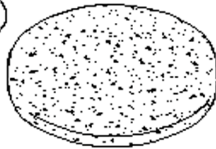

YELLOW - GELB - JEUNE  
 AMARILLO - GIALLO

⑦

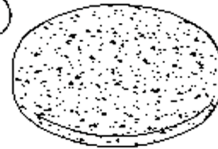

**BOXER-AUTOMATIC SWEEPER/SCRUBBER-pl1237**

POS.	PART #	DESCRIPTION	QTY.
1	AL04705	POLYPROPYLENE BRUSH	
2	AL04707	POLYSHING BRUSH	
3	AL04706	TYNEX BRUSHES	
4	AL04701	PAD DRIVER	
5	AL02219	STRIPPING PAD(BLACK)	
6	AL02220	STRIPPING PAD(GREEN)	
7	AL02221	STRIPPING PAD(YELLOW)	

## BOXER-AUTOMATIC SWEEPER/SCRUBBER-wd27182

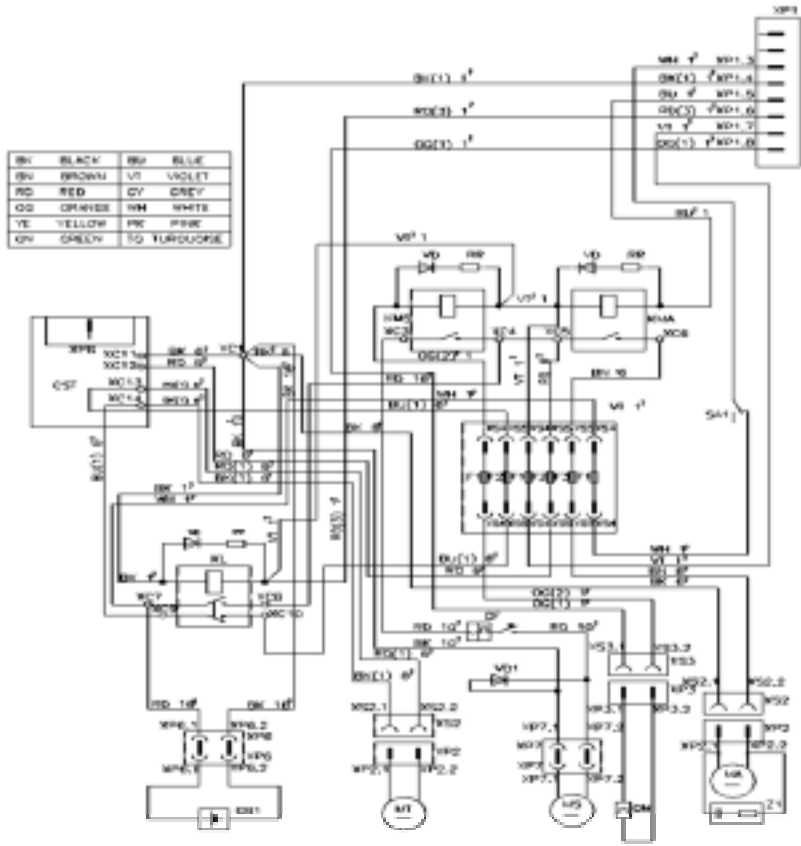

### BOXER-AUTOMATIC SWEEPER/SCRUBBER-wd27182

POS.	PART #	DESCRIPTION	QTY.
XP#		CONNECTOR	10
XS#		CONNECTOR	14
VD#		DIODE	4
RR		RESISTANCE	3
RP#		POTENTIOMETER	2
QF		MAGNETOTHERMAL SWITCH	1
QM		THERMAL PROTECTION	1
SA#		MICROSWITCH	3
SB#		MICROSWITCH	2
SF1		MUSHROOM SWITCH	1
SH#		SWITCH	2
KMA		VACUUM REMOTE CONTROL SWITCH	1
KMS		BRUSHES REMOTE CONTROL SWITCH	1
KL		REMOTE CONTROL REVERSER	1
MT		TRACTION MOTOR	1

**BOXER-AUTOMATIC SWEEPER/SCRUBBER-wd27182**

<b>POS.</b>	<b>PART #</b>	<b>DESCRIPTION</b>	<b>QTY.</b>
MA		VACUUM MOTOR	1
MS		BRUSHES MOTOR	1
Z1		FILTER	1
PV		INDICATOR	1
CST		TRACTION UNIT	1
F#		FUSE	6
GB1		BATTERY	6

# BOXER-AUTOMATIC SWEEPER/SCRUBBER-wd27182-1

BK	BLACK	BU	BLUE
BN	BROWN	VT	VIOLET
RD	RED	GY	GREY
OC	ORANGE	WH	WHITE
YE	YELLOW	PK	PINK
GN	GREEN	TO	TURQUOISE

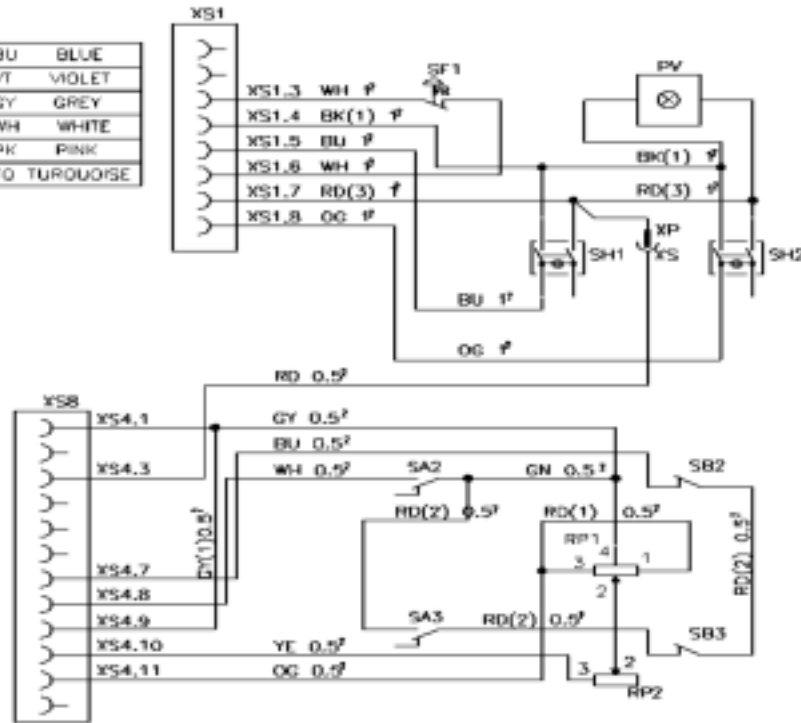

## BOXER-AUTOMATIC SWEEPER/SCRUBBER-wd27182-1

POS.	PART #	DESCRIPTION	QTY.
XP#		CONNECTOR	10
XS#		CONNECTOR	14
VD#		DIODE	4
RR		RESISTANCE	3
RP#		POTENTIOMETER	2
QF		MAGNETOTHERMAL SWITCH	1
QM		THERMAL PROTECTION	1
SA#		MICROSWITCH	3
SB#		MICROSWITCH	2
SF1		MUSHROOM SWITCH	1
SH#		SWITCH	2
KMA		VACUUM REMOTE CONTROL SWITCH	1
KMS		BRUSHES REMOTE CONTROL SWITCH	1
KL		REMOTE CONTROL REVERSER	1
MT		TRACTION MOTOR	1
MA		VACUUM MOTOR	1
MS		BRUSHES MOTOR	1
Z1		FILTER	1
PV		INDICATOR	1
CST		TRACTION UNIT	1
F#		FUSE	6
GB1		BATTERY	6

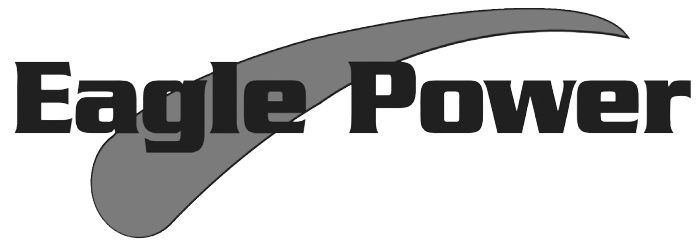

## Warranty Policy

### Limited Warranty

**Eagle Power Products (EPP) warrants new cleaning equipment against defects in material and workmanship under normal use and service to the original purchaser as detailed below.**

#### 10 Years

**Subject to the conditions stated below, EPP warrants polyethylene tanks and housings to be free from defects in materials and workmanship for a period of ten years.**

#### 3 Years

**Subject to the conditions stated below, EPP warrants all automatic scrubber components to be free from defects in materials and workmanship for a 3-year period. Parts replaced or repaired are warranted for the remainder of the original warranty period.**

#### 1 Year

**Subject to the conditions stated below, EPP warrants all other cleaning equipment components to be free from defects in materials and workmanship for a 1-year period. Parts replaced or repaired are warranted for the remainder of the original warranty period. Batteries are prorated for one year.**

**EPP will furnish and charge for replacement parts, including transportation, to the original owner through an EPP authorized service center. If the part is returned within 30 days and is found defective, the owner will be credited for the cost of the replacement part including shipping and handling.**

Labor charges are covered for one year from the date of purchase if provided by an authorized EPP service center. Travel is covered for 90 days for battery operated equipment only.

Wear items exempt from warranty include belts, carbon brushes, power cords, wheels, pad drivers, clutch plates, brushes, pads, handle grips, filters, screens, throttle cables, and squeegees.

This warranty shall not apply to failures caused by misuse or abuse, improper maintenance as stated in the operation manuals, use of unauthorized repair parts, repairs by other than an EPP authorized service center, and damage in transit.

EPP disclaims and denies any liability for any direct, indirect, special incidental or consequential damage which may be suffered as a result of sale, delivery, servicing, use, loss of any product, downtime, labor, freight, or other charges not expressly included herein.

Date Purchased: \_\_\_\_\_

Model Number: \_\_\_\_\_

Serial Number: \_\_\_\_\_

Please be sure to record this information. This information will be necessary for future warranty claims.



1174 Northland Drive Mendota Heights, MN 55120  
651.686.5399 Fax 651.686.5695  
www.eaglepower.com

*Eagle Power Products Sales and Service Provided by:*