



Electronic Service Manuals

This electronic document is provided as a service to our customers. We do not create the contents of the information contained in this document. Should you have detailed questions pertaining to the information contained in this document, you may contact Michco, or the manufacturer which provided the original information in this electronic deliverable. Michco's only part in this electronic deliverable was the electronic assembly process. By providing this manual on line we are not guaranteeing parts availability.

You may contact Michco through the following methods:

Phone (517) 484-9312 or (800) 331-3339

2011 N. High St. -- Lansing, Michigan -- 48906

Fax: (517) 484-9836

Email: CustServe@Michco.com

Web site: www.Michco.Com

Parts Web site: www.FloorMachineParts.Com

Order Parts on Line at:

www.FloorMachineParts.Com

Directly to Parts & Service:

By Email: **Shop@Michco.com**

By Fax: (517) 702-2041

By Voice: Use numbers above.

Serving the Cleaning Industry Since 1922

Notice: All copyrighted material remains property of original owners, all trademarks are property of respective owners. Manuals are subject to Manufacturer's reproduction limitations. Originals or reproductions were provided by manufacturers through a request. We make no warranty as to the correctness of information provided in this document and you assume all risk. By placing these manuals on line we are not declaring our corporation to be an manufacturer authorized dealer or provider, please check our web site for authorized manufacturers we represent.

CLEANMAX
ZM-200

PARTS BOOK

HANDLE

ZM-200

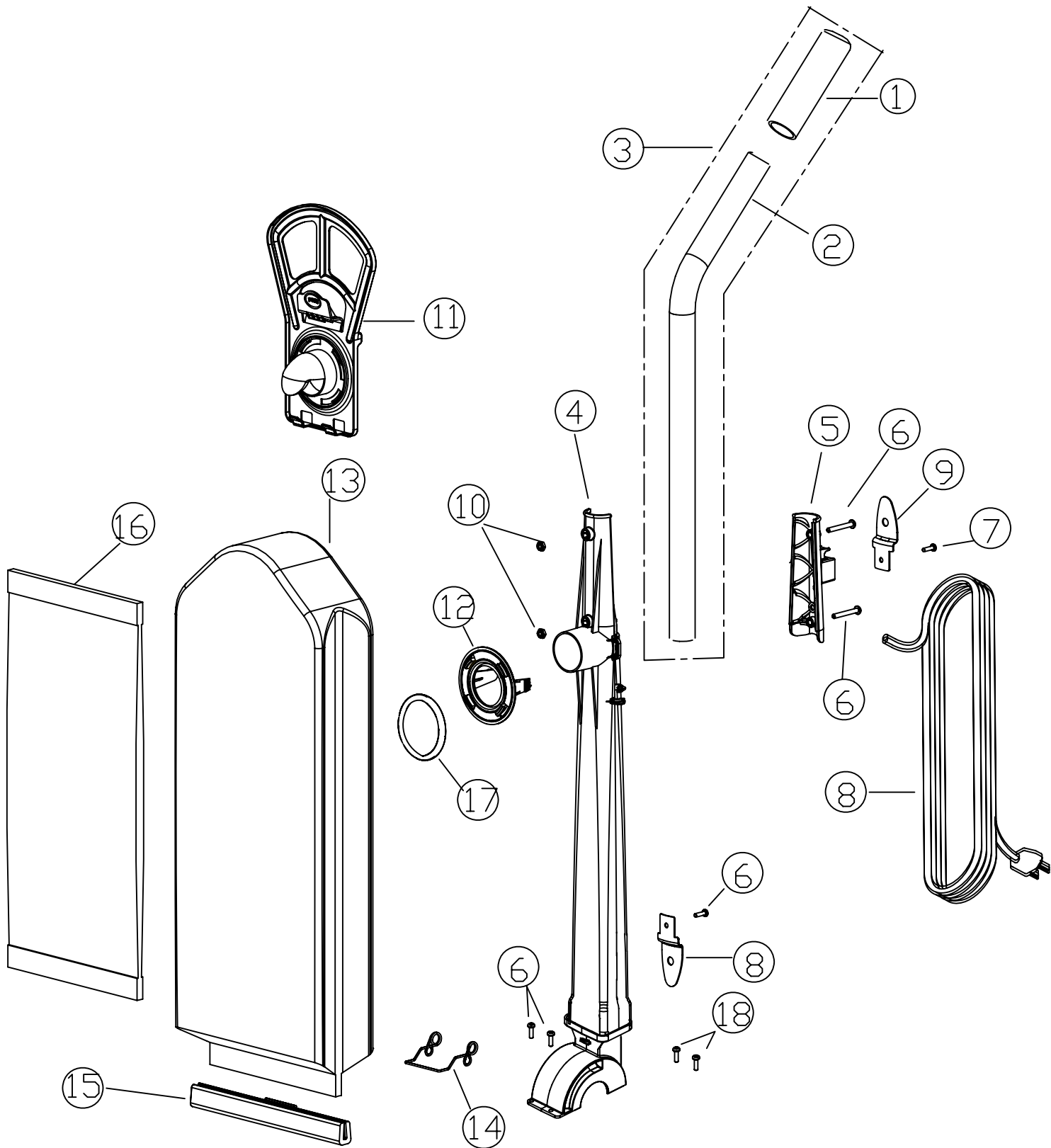

Key	Parts No.	Description
1	B431-2300	Handle Grip
2	B431-2406B	Handle Tube
3	D431-2406	Handle Tube Assembly with Grip
4	D431-3014	Lower Handle Upper Fan Housing
5	B431-2914E	Handle Tube Bracket
6	A432-0705	Screw, #10-32x1.625
7	A732-8314	Screw, #8x5/8"
8	A434-1241	Power Cord
9	B430-1205	Metal Cord Hook
10	A432-0805	Hex Nut
11	B211-2214	Bag Collar Bag Holder
12	B211-2114	Bag Collar Bag Ring
13	B211-3700	Cloth Bag
14	B211-1204	Lowr Bag Spring
15	B211-1914E	Lower Bag Clip
	A732-3600	Bag Clip Plug (Not Shown)
16	CMZM-H6	HEPA Bag (6 pack)
	CMZM-P6	Paper Bag (6 pack)
17	D211-5700	Bag Collar Seal
18	A732-9206	Screw

NOZZLE

ZM-200

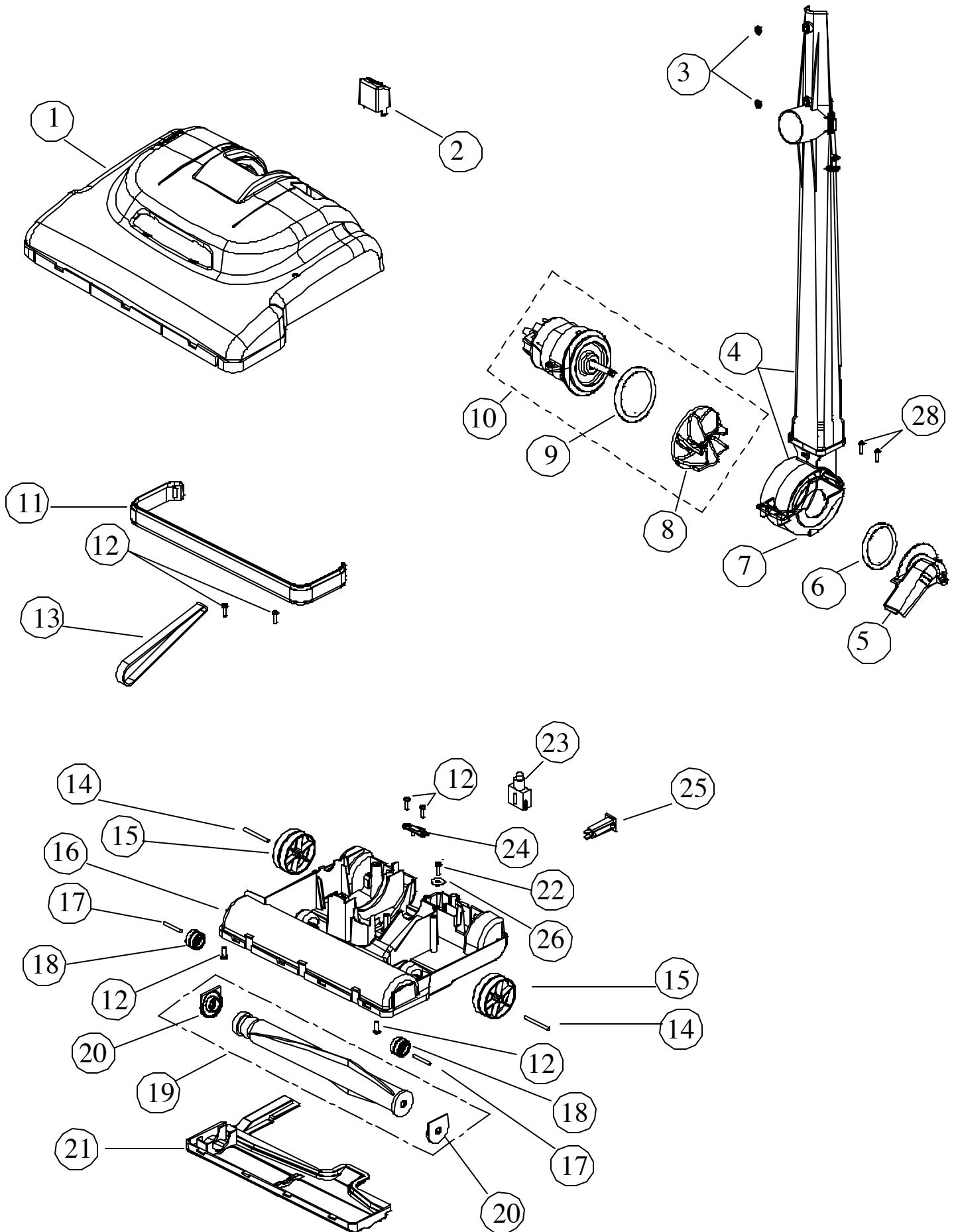

NOZZLE**ZM-200**

Key	Parts No.	Description
1	B017-3714	Nozzle Housing
2	B028-0014	Foot On/Off Pedal
3	A432-0805	Hex Nut
4	D431-3014	Lower Handle Upper Fan Housing Assembly
5	B123-3814	Fan Duct Cover
6	A121-0200E	Fan Duct Cover Felt Ring Seal
7	B123-3614	Lower Fan Housing
8	B123-3000	Fan
9	A121-0100E	Motor Bracket Felt Ring Seal
10	D113-1200	Motor/Fan Assembly
11	B029-0314	Furniture Guard
12	A732-8314	Screws
13	CMZM-BB	Belt (Bulk)
	CMZM-B2	Belt (2 pack)
14	B010-0101	Large Wheel Axle
15	B350-6531	Wheel Rear
16	D016-1114	Base Tray Assembly
17	B010-0001	Base Plate Wheel Axle
18	B010-2131	Base Plate Wheel
19	B012-2800C	Wood Agitator w/End Caps
20	B012-2914	End Cap
21	B015-2014	Base Plate Cover
22	A732-2500	Combination Screw (m4x12)
23	A028-0014	On/Off Foot Switch
24	B016-1230	Upright Stop
25	A028-0114	Circuit Breaker
26	B034-0100	Strain Relief Washer
	A732-3000	E-Clip for Motor Shaft (Not Shown)