



## Electronic Service Manuals

This electronic document is provided as a service to our customers. We do not create the contents of the information contained in this document. Should you have detailed questions pertaining to the information contained in this document, you may contact Michco, or the manufacturer which provided the original information in this electronic deliverable. Michco's only part in this electronic deliverable was the electronic assembly process. By providing this manual on line we are not guaranteeing parts availability.

You may contact Michco through the following methods:

Phone (517) 484-9312 or (800) 331-3339

2011 N. High St. -- Lansing, Michigan -- 48906

Fax: (517) 484-9836

Email: [CustServe@Michco.com](mailto:CustServe@Michco.com)

Web site: [www.Michco.Com](http://www.Michco.Com)

Parts Web site: [www.FloorMachineParts.Com](http://www.FloorMachineParts.Com)

Order Parts on Line at:

**[www.FloorMachineParts.Com](http://www.FloorMachineParts.Com)**

Directly to Parts & Service:

By Email: **[Shop@Michco.com](mailto:Shop@Michco.com)**

By Fax: (517) 702-2041

By Voice: Use numbers above.

**Serving the Cleaning Industry Since 1922**

Notice: All copyrighted material remains property of original owners, all trademarks are property of respective owners. Manuals are subject to Manufacturer's reproduction limitations. Originals or reproductions were provided by manufacturers through a request. We make no warranty as to the correctness of information provided in this document and you assume all risk. By placing these manuals on line we are not declaring our corporation to be an manufacturer authorized dealer or provider, please check our web site for authorized manufacturers we represent.

# UZ 964

Ergoclean, HipVac™

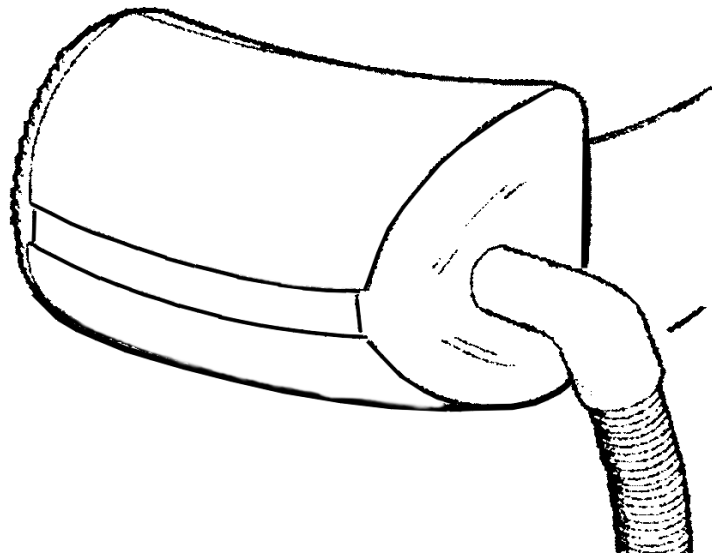

## SPARE PARTS LIST

**WHEN ORDERING PARTS ALWAYS STATE:**

- \* The 10 digit part numbers
- \* Quantity,
- \* Specify the model and serial numbers of the machine.

**For Electrical details also:**

- \* Voltage
- \* Wattage

**SPARE PARTS LIST - UZ 964**

**PRINTED  
PARTS  
LIST**

**2**

**LINE DRAWING**

**06-03**

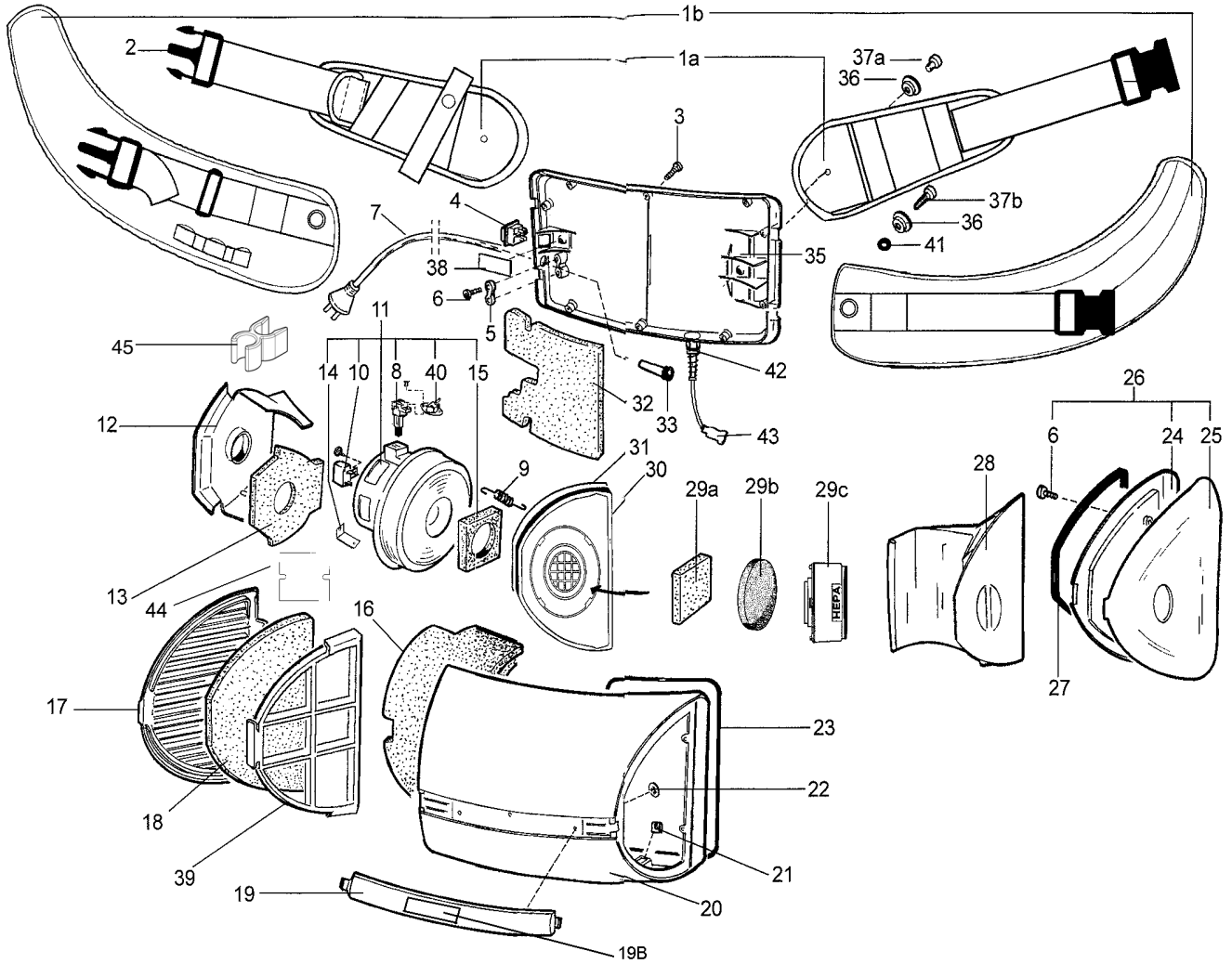

ItemNo	Qty.	Part No	Description
1a	1	<b>P</b> 140 7096 000	Belt cpl.w.locking
1b	1	140 7343 000	Belt cpl.w.locking (US-version)
2	1	140 7074 000	Locking cpl.
3	10	140 9214 150	Screw
4	1	140 5496 510	Switch
5	1	056 1014 060	Anti strain clip
	1	140 6560 000	Anti strain clip, UL-approved
6	4	140 9214 040	Screw
7	1	See page 7	Cord set
8	2	142 0947 000	Carbon brush, for 230-240V, for Tech fan units
	2	142 0947 010	Carbon brush, for 115-120V, for Tech fan units
	2	142 0947 020	Carbon brush, for 100-110V, for Tech fan units
	2	140 9885 000	Carbon brush, for 140 7143 010 400Hz motor
	2	140 8092 500	Carbon brush kit, for all VM 3 fan units
9	4	140 6792 000	Spring
10	1	140 6916 000	Suppressor - Capicator, for old type of fan unit
	1	140 8166 010	Suppressor - Capicator, for 140 8077 xxx fan unit
11	1	See page 7	Fan unit
12	1	140 6633 000	Silencer
	1	140 6633 010	Silencer, UL-approved
13	1	140 6558 000	Insulation, silencer
14	1	<b>P</b> 140 4325 000	Grounding plate
15	1	140 6791 000	Gasket
16	1	140 6556 000	Insulation, cover
17	1	140 6448 000	Exhaust gable, blue
	1	140 6448 030	Exhaust gable, grey
	1	140 6448 040	Eaxhaust gable, Alto-blue
18	1	140 6597 000	Exhaust filter
18b	1	>> 140 6597 500	Exhaust filter 3 pcs
19	1	<b>P</b> 140 6426 000	Cover strip, orange
	1	<b>P</b> 140 6426 010	Cover strip, orange UL-approved
	1	140 6426 030	Cover strip, grey
19b	1	140 7768 000	Label, Euroclean by N-A
	1	140 7861 010	Label, Euroclean HipVac Sr
	1	140 7769 000	Label, Nilfisk by N-A
20	1	140 6443 000	Cover, blue
	1	140 6443 060	Cover Alto-blue, UL-approved
	1	140 6443 040	Cover, grey
	1	140 6443 050	Cover, grey UI-approved
21	6	140 6796 000	C-clip
22	3	140 6797 000	Spring nut
23	1	140 6798 000	Gasket
24	1	140 6446 000	Inner suction gable, blue UL -approved
	1	140 6446 030	Inner suction gable, grey
	1	140 6446 040	Inner suction gable, Alto-blue UL -approved
25	1	140 6447 000	Outer suction gable, blue UL-approved
	1	140 6447 030	Outer suction gable, grey
	1	140 6447 040	Outer suction gable, Alto-blue UL-approved
26	1	140 6699 000	Suction gable compl. blue
	1	140 6699 030	Suction gable compl. grey
	1	140 6699 040	Suction gable compl. Alto-blue
27	1	140 7302 000	Gasket
28	1	140 6554 010	Dust bag 5-pack
	1	140 6554 020	Dust bag 10-pack
	1	140 6554 030	Dust bag high filtration, 1-pack
	1	140 6554 040	Dust bag high filtration, 5-pack
	1	140 6554 050	Dust bag high filtration, 10-pack
29a	1	140 6794 000	Pre filter, older version
29b	1	140 6794 010*	Pre filter, new version
29c	1	140 7160 010*	Hepa-filter, cpl.
29d	1	140 5666 000	Gasket
30	1	140 7148 000	Partition wall
	1	140 7148 010	Partition wall, UL-approved
31	1	140 6799 000	Gasket

\* Only for machines from serial no. 951400001/51400001

>> Means: New or changed ref. number or/and changed/new specifications.  
**P** Means: Depleted when no longer on stock

SPARE PARTS LIST - UZ 964

PRINTED  
PARTS  
LIST

4

LINE DRAWING

06-03

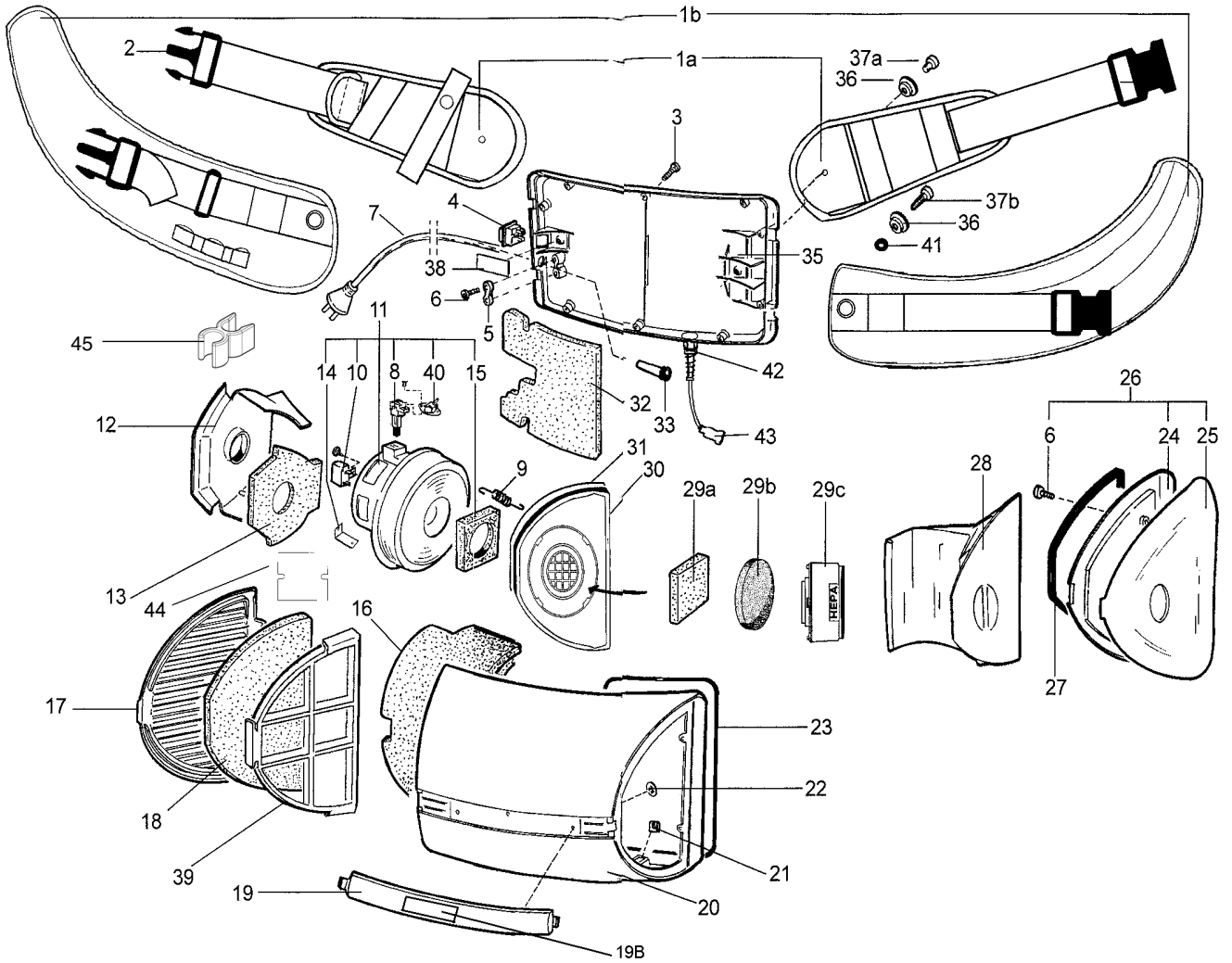

<b>PRINTED PARTS LIST</b>	<b>SPARE PARTS LIST - UZ 964</b>			
<b>06-03</b>	<b>PARTS NUMBER</b>			<b>5</b>

<u>ItemNo</u>	<u>Qty.</u>	<u>Part No</u>	<u>Description</u>
32	1	140 6557 000	Insulation, back
33	1	>> 140 7035 500	Protection sleeve
	1	>> 140 7035 510	Protection sleeve, US versions
35	1	140 6444 000	Back part, blue
	1	140 6444 020	Back part, blue, UL-approved
	1	140 6444 040	Back part, blue UL-appr. w. hole for outlet
	1	140 6444 050	Back part, grey
	1	140 6444 060	Back part, grey, UL-approved
	1	>> 140 6444 070	Back part, Alto-blue, UL-approved
		>> 140 6906 060	Back part cpl. Alto blue UL-approved
		140 6906 030	Back part cpl. grey
		140 6906 040	Back part cpl. grey UL-approved
		140 6906 050	Back part cpl. blue UL-approved w. hole for outlet
36	2	140 7696 000	Washer
37a	2	140 6559 000	Screw for belt 140 7096-000
37b	2	140 6559 010	Screw for belt 140 7343-000
38	1	140 5358 000	Insulation
39	1	140 6824 000	Filter holder
40	1	140 3894 500	Thermo protector, for old type of fan unit
42	1	140 5674 010	Connect.w.sleeve only for 905 2419, 905 2420
43	1	140 7311 000	Outlet f. power nozzle only for 905 2419
	1	140 7692 000	Outlet f.power nozzle only for 905 2420
44	1	140 7691 000	Insulating plate,110VAirpl.model
45	1	147 0808 500	Cord clip, for EU cord set.
45	1	>> 147 0808 510	Cord clip, for US/Can, TW, JP cord set.

>> Means: New or changed ref. number or/and changed/new specifications.  
P Means: Depleted when no longer on stock.

**Notes:**

The washer 140 6790 000 and spacer 140 7318 000 for fastening the belt to the back cover, is replaced by washer 140 7696 000.

**6**

**FAN UNITS, CORD SETS**

**02-08**

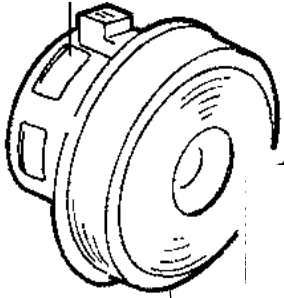

11



7

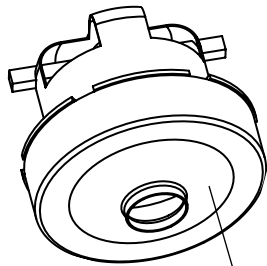

11B

<b>PRINTED PARTS LIST</b>	<b>SPARE PARTS LIST - UZ 964</b>			
	<b>06-10</b>	<b>FAN UNITS, CORD SETS</b>		<b>7</b>

<b>ItemNo.</b>	<b>Qty.</b>	<b>Part No.</b>	<b>Description</b>
7	1	>> 140 6423 500	Cord set 15 m, EU Double insulated
7	1	>> 140 6702 500	Cord set 15 m, JP
7	1	>> 140 6423 530	Cord set 15 m, UK
7	1	>> 140 6423 520	Cord set 15 m, CH
7	1	>> 140 3608 070	Cord set 20 m, US/JP for Aeroplane version
7	1	>> 140 6676 520	Cord set 15 m, AU
7	1	140 3859 050	Cord set 15 m, US, Grounded
11	1	<b>P</b> 140 8077 500	Fan unit 230-240V, 700W
11	1	<b>P</b> 140 8077 510	Fan unit 120V, 700W
11	1	<b>P</b> 140 8077 520	Fan unit 100-115V, 700W
11	1	<b>P</b> 140 8077 530	Fan unit 120W, 1000W
11	1	<b>P</b> 140 7143 010	Fan unit 120V 400Hz -Aeroplane version
11B	1	>>147 1120 500	FAN UNIT KIT AMETEK 700W 230-240V
11B	1	>>147 1120 510	FAN UNIT KIT AMETEK 700W 120V
11B	1	>>147 1120 520	FAN UNIT KIT AMETEK 700W 100V
11B	1	>>147 1120 540	FAN UNIT KIT AMETEK1000W 120V
11B	1	>>147 1134 500	FAN UNIT KIT AMETEK 120V 400Hz - Aeroplane version

>> Means: New or changed ref. number or/and changed/new specifications.

**P** Means: depleted when no longer on stock

**WHEN ORDERING PARTS ALWAYS STATE:**

- \* The 10 digit part numbers
- \* Quantity,
- \* Specify the model and serial numbers of the machine.

**For Electrical details also:**

- \* Voltage
- \* Wattage

SPARE PARTS

8

NOZZLES & HOSE, LINE DRAWING

06-09

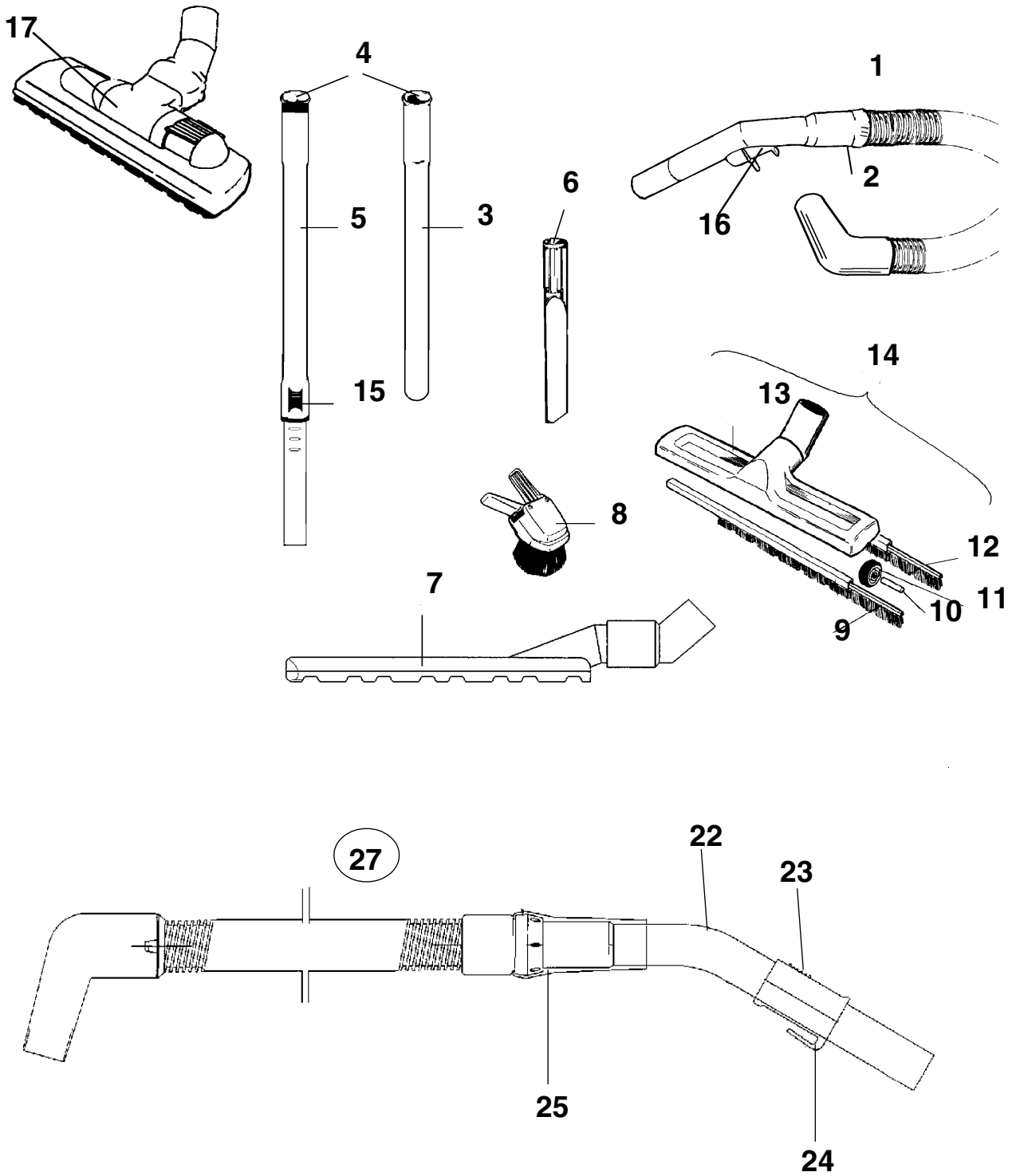

<b>PRINTED PARTS LIST</b>	<b>SPARE PARTS</b>			
	<b>06-01</b>	<b>NOZZLES &amp; HOSE, PART NUMBERS</b>		<b>9</b>

<u>Item.</u>	<u>Qty.</u>	<u>Part No</u>	<u>Description</u>	
1	1	140 7082 000	Hose with sleeve	
1	1	140 5691 000	Hose cpl. With bent end piece and sleeve Ø 0.10 ft (32 mm) Black hose, plastic bent end	
2	1	>> 140 7584 500	Bent end piece cpl. Plastic	
3	2	>> 011 6431 500	Extension tube, al. 50 cm -19.6 in	
3	2	032 3290 010	Extension tube, pl.	
4	2	011 3199 010	Insert, for aluminum extension tubes	
5	1	>> 011 8130 500	Telescopic extension tube aluminium 630 -950 mm	
6	1	>> 010 3098 500	Crevice nozzle	
7	1	140 7547 000	Paddle nozzle	
8	1	>> 011 3104 500	Small comb. nozzle	
9	1	<b>P</b> 140 8741 000	Brush strip, front	
10	2	<b>P</b> 140 8744 000	Shaft	
11	2	<b>P</b> 140 8743 000	Wheel	
12	1	<b>P</b> 140 8741 010	Brush strip, rear	
13	1	<b>P</b> 140 8740 000	Top	
14	1	>> 140 6700 540	Nozzle compl.	
15	1	<b>P</b> 011 8136 020	Regulator	
16	1	<b>P</b> 012 5475 000	Rubber packing	
17	1	>> 140 7087 500	Combination nozzle	
18	1	<b>P</b> 145 9928 000	Base plate cpl.	
19	1	<b>P</b> 145 9929 000	Brush	
20	2	<b>P</b> 093 1813 000	Little Picker	
21	1	<b>P</b> 145 9930 000	Bottom plate	
22	1	>> 011 6432 510	Bent end piece. Aluminium	
23	1	>> 010 9613 080	Suction control	
24	1	>> 010 9614 080	Retainer	
25	1	>> 011 8209 030	Sleeve	
27	1	>> 140 8070 000	Hose cpl. with bent end	Ø 0.10 ft (32 mm) Black hose, Aluminium bent end

>> Means: New or changed ref. number or/and changed/new specifications.

**P** Means: depleted when no longer on stock

Termoskydd ingår i motorn.  
Thermal protection incl. in motor.

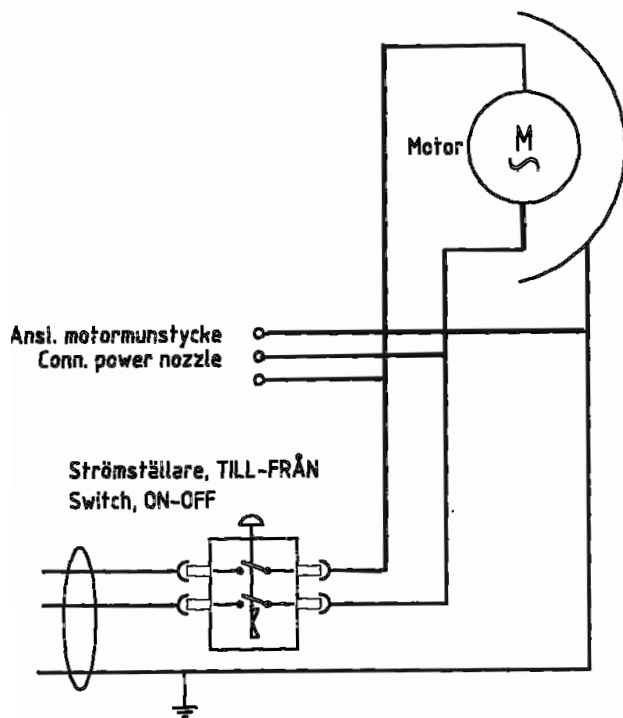

Jordad med motormunstycke  
Grounded with power nozzle

WIRING DIAGRAM  
FOR 140 8077 XXX  
FAN UNITS

Termoskydd ingår i motorn.  
Thermal protection incl. in motor.

WIRING DIAGRAM  
FOR 140 8077 XXX  
FAN UNITS

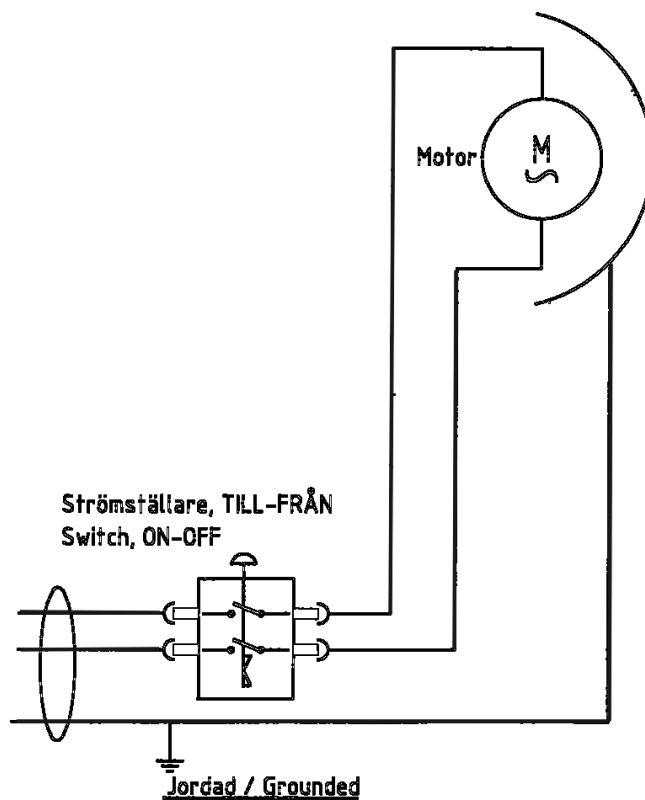

Termoskydd ingår i motorn.  
Thermal protection incl. in motor.

WIRING DIAGRAM  
FOR 140 8077 XXX  
FAN UNITS

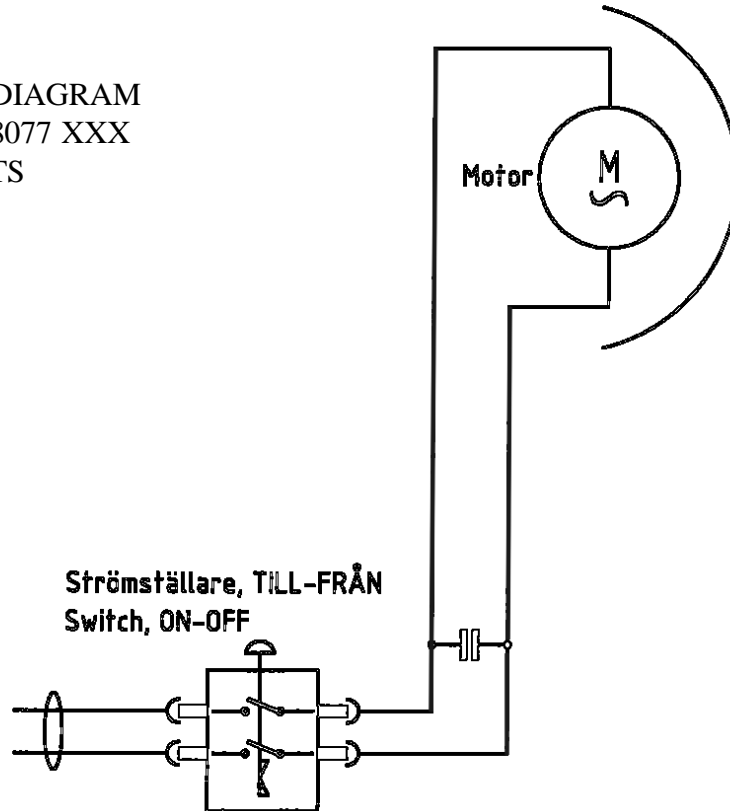

WIRING DIAGRAM FOR  
Aeroplane versions  
with thermal protector  
110V/400 Hz

