



Electronic Service Manuals

This electronic document is provided as a service to our customers. We do not create the contents of the information contained in this document. Should you have detailed questions pertaining to the information contained in this document, you may contact Michco, or the manufacturer which provided the original information in this electronic deliverable. Michco's only part in this electronic deliverable was the electronic assembly process. By providing this manual on line we are not guaranteeing parts availability.

You may contact Michco through the following methods:

Phone (517) 484-9312 or (800) 331-3339

2011 N. High St. -- Lansing, Michigan -- 48906

Fax: (517) 484-9836

Email: CustServe@Michco.com

Web site: www.Michco.Com

Parts Web site: www.FloorMachineParts.Com

Order Parts on Line at:

www.FloorMachineParts.Com

Directly to Parts & Service:

By Email: **Shop@Michco.com**

By Fax: (517) 702-2041

By Voice: Use numbers above.

Serving the Cleaning Industry Since 1922

Notice: All copyrighted material remains property of original owners, all trademarks are property of respective owners. Manuals are subject to Manufacturer's reproduction limitations. Originals or reproductions were provided by manufacturers through a request. We make no warranty as to the correctness of information provided in this document and you assume all risk. By placing these manuals on line we are not declaring our corporation to be an manufacturer authorized dealer or provider, please check our web site for authorized manufacturers we represent.

Clarke CA30 20B and 17E



Service Manual

Model numbers:

CA30 20B - CLARKE510B

CA30 17E - CLARKE430C

Clarke®

English

12/15 Revised 2/16 Form No. 56043171

Contents

| | |
|--|-----------|
| General Information | .5 |
| General Machine Description | 5 |
| Service Manual Purpose and Application | 5 |
| Other Reference Manuals and Information Sources. | 5 |
| Parts And Service. | 5 |
| Name Plate | 5 |
| Safety | 6 |
| <i>Symbols</i> | 6 |
| <i>General Safety Instructions</i> | 6 |
| <i>Property Damage Messages.</i> | 7 |
| 120 VAC Power Cord Requirements (Corded Machine) | 7 |
| Lifting The Machine | 8 |
| Transporting The Machine. | 8 |
| Technical Specifications | 8 |
| Maintenance Schedule. | 9 |
| Know Your Machine | 10 |
| CA30 20B. | 10 |
| CA30 17E. | 11 |
| Control System (Corded Model) | 12 |
| Functional Description | 12 |
| <i>Control Panel</i> | 12 |
| Schematic | 13 |
| <i>Main Power</i> | 13 |
| <i>Vacuum Motor.</i> | 13 |
| <i>Solution Solenoid</i> | 14 |
| <i>Brush Motor and Starter</i> | 14 |
| <i>Motor Start Relay.</i> | 14 |
| <i>Scrub Control Relay</i> | 15 |
| Troubleshooting | 16 |
| <i>Whole Machine Not Functioning.</i> | 16 |
| Removal and Installation. | 17 |
| <i>Rear Covers (Control Cover)</i> | 17 |
| <i>Control Panel</i> | 18 |
| <i>Relays and Brush Motor Capacitors</i> | 19 |
| Control System (Battery Model) | 20 |
| Functional Description | 20 |
| <i>Control Panel</i> | 20 |
| <i>Main Power Switch</i> | 20 |
| <i>Battery Charger</i> | 21 |
| <i>Vacuum Motor.</i> | 21 |
| <i>Solution Solenoid</i> | 21 |
| <i>Brush Motor</i> | 21 |
| <i>Vacuum, Solution, and Brush Switches</i> | 21 |
| <i>Hour Meter.</i> | 21 |
| <i>Battery Meter LEDs</i> | 21 |
| Schematic | 22 |
| Troubleshooting | 23 |

| | |
|--|-----------|
| Whole Machine Not Functioning | 23 |
| Machine Enable Circuit | 23 |
| Power, Vacuum, Solution, and Brush Switches | 25 |
| Removal and Installation | 26 |
| Rear Covers (Control Cover) | 26 |
| Control Panel | 27 |
| Control Board | 28 |
| Brush Motor relay | 28 |
| Batteries | 30 |
| Setting AGM/Wet Battery Type | 32 |
| Battery Charger | 33 |
| Battery Type Dip-Switches | 33 |
| Specifications | 34 |
| Shop Measurements | 34 |
| Recovery System | 35 |
| Functional Description | 35 |
| Troubleshooting | 36 |
| Vacuum Motor (17E) | 36 |
| Vacuum Motor (20B) | 36 |
| Weak Suction | 36 |
| Removal and Installation | 37 |
| Vacuum Motor | 37 |
| Replacement Notes | 38 |
| Vacuum Motor Brushes | 39 |
| Scrub System | 41 |
| Functional Description | 41 |
| Troubleshooting | 42 |
| Brush Motor (17E) | 42 |
| No Power | 42 |
| Low Speed, lack of Power, or Overheating | 42 |
| Start Relay Troubleshooting Voltage Readings | 43 |
| Scrub System (17E) | 44 |
| Brush Motor (20B) | 45 |
| Removal and Installation | 46 |
| Scrub Deck | 46 |
| Replacement Notes | 47 |
| Brush Drive Belt | 48 |
| Replacement | 48 |
| Motor Carbon Brushes (Battery Model) | 49 |
| Solution System | 51 |
| Functional Description | 51 |
| Maintenance and Adjustment | 52 |
| Solution Filter Cleaning | 52 |
| Troubleshooting | 53 |
| Solution Solenoid (17E) | 53 |
| Solution Solenoid (20B) | 53 |
| Removal and Installation | 54 |
| Solution Solenoid | 54 |

| | |
|---|-----------|
| Squeegee System | 55 |
| Functional Description | 55 |
| Troubleshooting | 55 |
| <i>Floor Streaks</i> | 55 |
| Maintenance and Adjustment. | 56 |
| <i>Squeegee Blade Changing</i> | 56 |
| <i>Squeegee Trim Adjustment</i> | 58 |

General Information

General Machine Description

The CA30 is a walk-behind commercial floor scrubbing machine designed to wash and dry commercial floors. The machine is powered by either on-board batteries (Battery version) or with electric mains via power cord (corded version). The machine is equipped with a single-disc scrubbing pad, a controlled solution flow dosing system, and a rear squeegee with vacuum suction. The machine also has an on-board solution tank and wastewater recovery tank. This machine is not to be used outdoors, on carpets, or on coarse floors.

Service Manual Purpose and Application

This Service Manual a technical resource intended to aid service personnel in maintaining and repairing the CA30 to ensure optimum performance and long service life. Please read this manual carefully before performing any maintenance and repair procedure on the machine.

Other Reference Manuals and Information Sources

| Document Name | Document Number | Document Type |
|--------------------------------|-----------------|------------------------|
| CA30 17E, Instructions for Use | 56091131 | User Manual/Parts List |
| CA30 20B, Instructions for Use | 56091130 | User Manual/Parts List |

Parts And Service

Service and repairs must be performed only by authorized personnel or Nilfisk Service Centers. The authorized personnel is trained directly at the manufacturer’s premises and has original spare parts and accessories.

Contact Nilfisk Retailer indicated below for service or to order spare parts and accessories, specifying the machine model and serial number.

Name Plate

The Model Number and Serial Number of your machine are shown on the Nameplate on the machine. This information is needed when ordering repair parts for the machine. Use the space below to note the Model Number and Serial Number of your machine for future reference.

MODEL NUMBER _____

SERIAL NUMBER _____



Safety

Symbols

It is important for you to read and understand this manual. The information it contains relates to protecting your safety and preventing problems. The symbols below are used to help you recognize this information.



Warning: Indicates a potentially hazardous situation which, if not avoided, could result in death or serious injury.



Caution: Indicates a potentially hazardous situation which, if not avoided, could result in minor or moderate injury.

Caution: When used without the Safety Alert Symbol, indicates a potential situation which, if not avoided, could result in property or machine damage.



Note: Indicates an important informational message.

General Safety Instructions

These safety instructions are included to warn you of potential bodily injury or property damage.



Caution! Read and understand all safety warnings and instructions. Failure to follow the warnings and instructions may result in electric shock, fire, and/or serious injury.

- To avoid personal injury, this machine should be used only by properly trained and authorized persons.
- Do not operate the machine near toxic, dangerous, flammable and/or explosive materials. This machine is not suitable for collecting dangerous or hazardous materials.
- In case of fire, use a powder fire extinguisher, not a water-based extinguisher.
- Do not use on surfaces having a gradient exceeding that marked on the machine. While on ramps or inclines, avoid sudden stops when loaded. Avoid abrupt sharp turns.
- Disconnect the power source and/or batteries before servicing electrical components
- Never work under a machine without safety blocks or stands to support the machine.
- Do not dispense flammable cleaning agents, operate the machine on or near these agents, or operate in areas where flammable liquids exist.
- When using floor cleaning detergents, follow all safety and handling instructions of the respective manufacturer.
- Battery charging may produce highly explosive hydrogen gas. Charge the batteries only in well-ventilated areas and away from ignition sources or open flames.
- When operating this machine, ensure that third parties, particularly children, are not endangered.
- Take precautions to prevent hair, jewelry, or loose clothing from becoming caught in moving parts.

Property Damage Messages

- Storage and operation temperature must be above 0°C and a humidity between 30% and 95%, non-condensing.
- Before use, all doors and hoods should be properly latched.
- This machine is not approved for use on public paths or roads.
- This machine is only approved for hard surface use.
- Use brushes and pads supplied with the machine or those specified in the User Manual. Using other brushes or pads could reduce safety.
- Do not wash the machine with direct or pressurised water jets, or with corrosive substances.
- Do not allow the brush/pad to operate while the machine is stationary to avoid damaging the floor.
- Use only factory authorized parts and accessories.
- This machine must be properly disposed of in accordance with local laws and regulations.

120 VAC Power Cord Requirements (Corded Machine)

This machine is equipped with a grounding power cord, and must be connected to a grounded facility receptacle that is installed in accordance with all applicable codes and ordinances. The ground wire provides a low resistance path for fault current, in the event of an equipment malfunction.



Warning: To reduce the chance of electrocution or serious injury, follow all instructions and warnings below.

The machine comes equipped with a short power cord, and must be used with an additional extension power cord. This extension cord must be of the appropriate type, size, and length as described below.

- The cord must be a 3-wire (including ground) flexible cord with a minimum length of 15 feet.
- The cord type letter designations must have (S) or (SJ) as the first digits, but cannot have (SV) or (SP) as the first digits. Additional letter designations with (W) or (OW) are preferred but not required. For example, a cord designated (SJOW) is Extreme-Service, Junior-Grade (300V), with Oil and Weather resistance.
- The minimum size of the power cord's conductors will vary according to the length of the cord. This is to minimize the effects of voltage-drop at the machine, which can reduce machine performance.

| Extension Cord Ratings | | |
|------------------------|-----------------|-------------------------|
| Cord Length | Size (AWG) | Size (mm ²) |
| <25 Ft. | 14 | 2.0 |
| 25-50 Ft. | 12 | 2.5 |
| 50-100 Ft. | 10 | 3.5 |
| >100 Ft. | Not recommended | |

- Minimum rating: 300V 140/167°F (60/75°C)

Improper connection of the equipment-grounding conductor can result in a risk of electric shock. Check with a qualified electrician or service person if you are in doubt as to whether the outlet is properly grounded. Do not modify the plug provided with the machine. If it will not fit the outlet, have a proper outlet installed by a qualified electrician.

Replace the plug if the grounding pin is damaged or broken. The Green (or Green/Yellow) wire in the cord is the grounding wire. When replacing a plug, this wire must be attached to the grounding pin only.

Lifting The Machine



Caution! Never work under a machine without safety stands or blocks to support the machine.

Transporting The Machine



Caution! Before transporting the machine on an open truck or trailer, make sure that . . .

- All covers are closed
- The recovery tank and detergent tank are empty
- Batteries (if so equipped) are disconnected
- The machine is securely fastened in place on the transport

Technical Specifications

| Model | CA30 20B | CA30 17E |
|---|-------------------------------|--------------------------|
| Machine Height | 980mm (39 in.) | 980mm (39 in.) |
| Solution tank capacity | 40 liter (10.5 gal.) | 50 liter (15.2 gal.) |
| Recovery tank capacity | 40 liter (10.5 gal.) | 50 liter (15.2 gal.) |
| Diameter of transport wheel | 200mm (8 in.) | 200mm (8 in.) |
| Diameter of guide wheel | 63.5mm (2.5 in.) | 63.5mm (2.5 in.) |
| Power of vacuum system motor | 350w | 400w |
| Maximum gradient when working | 2% (Max) | 2% (Max) |
| Sound pressure level at workstation | 70dB(A) ±3dB(A) | 72dB(A) ±3dB(A) |
| Standard batteries | (2×12V) 24V 105Ah AGM | N/A |
| Power Cord Length | N/A | 20m |
| Battery compartment size (W x L x H) | 340 x 330 x 260mm | N/A |
| Vacuum system circuit capacity | 1200 mm H ₂ O | 1200 mm H ₂ O |
| Cleaning width | 510mm (20 in.) | 430mm (17 in.) |
| Squeegee width | 790mm (31 in.) | 730mm (28.7 in.) |
| Machine length | 1100mm (43 in.) | 1060mm (42 in.) |
| Machine width without squeegee | 540mm (21 in.) | 480mm (19 in.) |
| Brush diameter | 510mm (20 in.) | 430mm (17 in.) |
| Dry Weight | 128kg (282 lb) with batteries | 70kg (154 lb) |
| Gross weight of the machine ready for use | 168kg (370 lb) | 120kg (265 lb) |
| Brush motor power | 560W | 750W |
| Brush speed | 150rpm | 150rpm |
| Brush /pad-holder Maximum pressure | 35kg (77 lb) | 32kg (70 lb) |
| Packing size (Lx W x H) | 1200 x 610 x 1170mm | 1200 x 610 x 1170mm |

Maintenance Schedule

| Procedure | Daily, after use | Weekly/ Monthly | Every 6 Months | Annually |
|--|---------------------|--------------------|-------------------|----------|
| Charge Battery | X | | | |
| Clean squeegee blades | X | | | |
| Inspect pad/brush | X | | | |
| Clean solution and recovery tanks | X | | | |
| Inspect power cord (corded model) | X | | | |
| Inspect squeegee blades for damage | | X | | |
| Clean the solution filter | | X | | |
| Inspect for loose fasteners and electrical connections | | | X ¹ | |
| Inspect/replace scrub motor brushes (battery model) | | | | X |
| Inspect/replace vacuum motor brushes | | | | X |

1 Also perform this inspection after the initial 10 hours of new machine usage.

Know Your Machine

CA30 20B

- | | | | |
|------------------------|--------------------------|-------------------------|---------------------------|
| 1. Brush Switches | 10. Squeegee Lift Handle | 19. Solution Tank Fill | 28. Vacuum Tube |
| 2. Handle | 11. Recovery Tank Drain | 20. Scrub Deck | 29. On-Board Charger |
| 3. Control Panel | 12. Squeegee Pivot | 21. Brush/Pad Holder | 30. Battery Low LED |
| 4. Serial Number Plate | 13. Squeegee Adjust | 22. Solution Sight Tube | 31. Battery Level LEDs |
| 5. Control Cover | 14. Squeegee Thumbscrews | 23. Shut-Off Float | 32. Power Switch |
| 6. Charging Indicator | 15. Squeegee Clip | 24. Vacuum Motor | 33. Vacuum Switch |
| 7. Circuit Breakers | 16. Squeegee Blade | 25. Brush Motor | 34. Solution Switch |
| 8. Battery Disconnect | 17. Recovery Tank Lid | 26. Wheels | 35. Hour Meter (optional) |
| 9. Lower Cover | 18. Recovery Tank | 27. Batteries | |

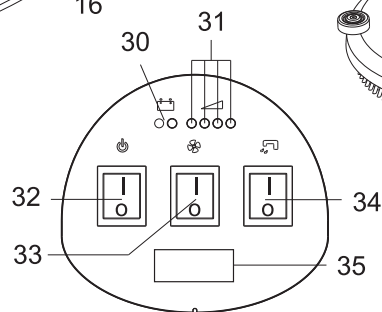
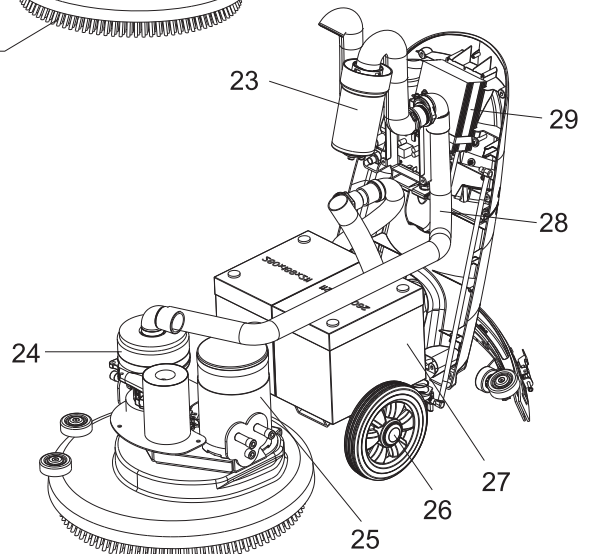
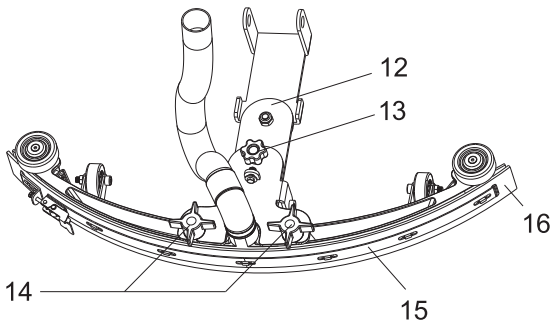
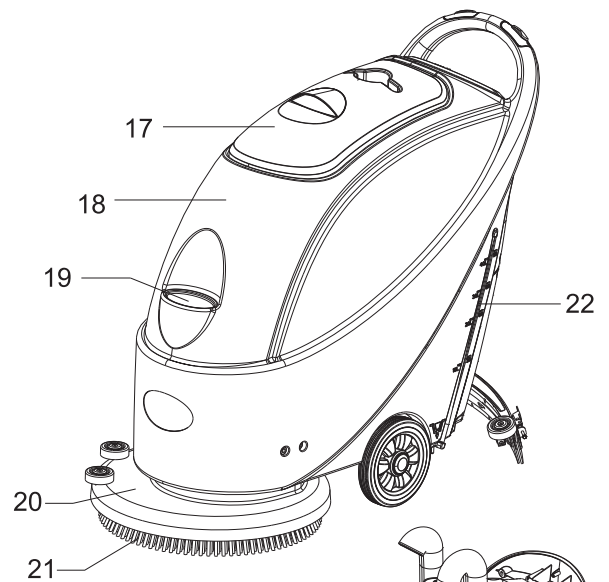
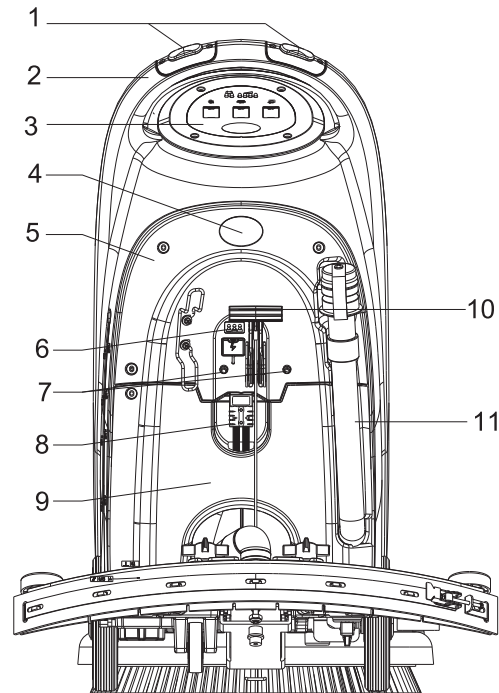

CA30 17E

- | | | | |
|------------------------|--------------------------|-------------------------|---------------------|
| 1. Brush Switches | 10. Squeegee Lift Handle | 19. Solution Tank Fill | 28. Vacuum Tube |
| 2. Handle | 11. Recovery Tank Drain | 20. Scrub Deck | 29. Electrical Box |
| 3. Control Panel | 12. Squeegee Pivot | 21. Brush/Pad Holder | 30. N/A |
| 4. Serial Number Plate | 13. Squeegee Adjust | 22. Solution Sight Tube | 31. N/A |
| 5. Control Cover | 14. Squeegee Thumbscrews | 23. Shut-Off Float | 32. Power Switch |
| 6. N/A | 15. Squeegee Clip | 24. Vacuum Motor | 33. Vacuum Switch |
| 7. Circuit Breakers | 16. Squeegee Blade | 25. Brush Motor | 34. Solution Switch |
| 8. Power Cord | 17. Recovery Tank Lid | 26. Wheels | |
| 9. Lower Cover | 18. Recovery Tank | 27. N/A | |

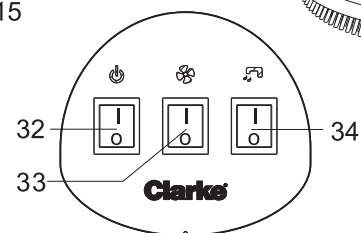
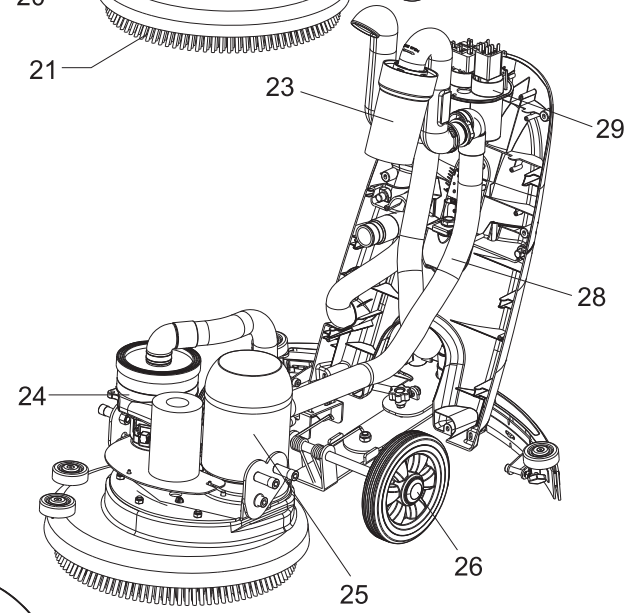
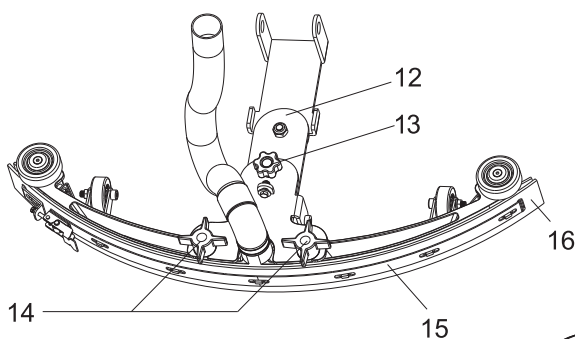
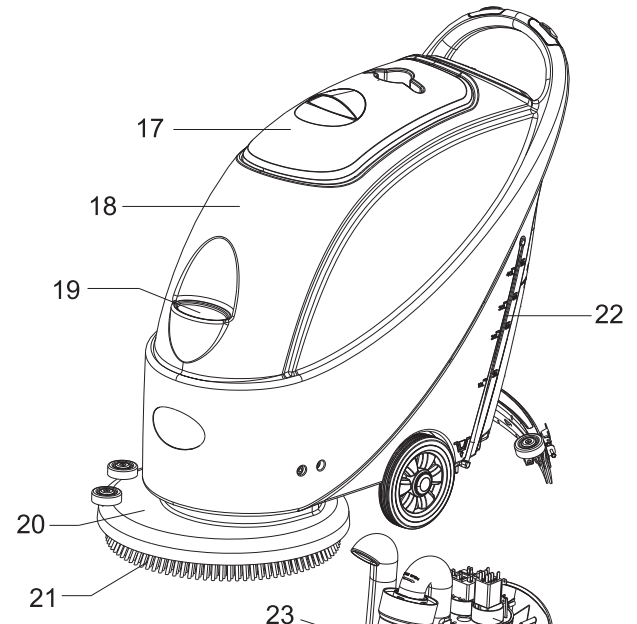
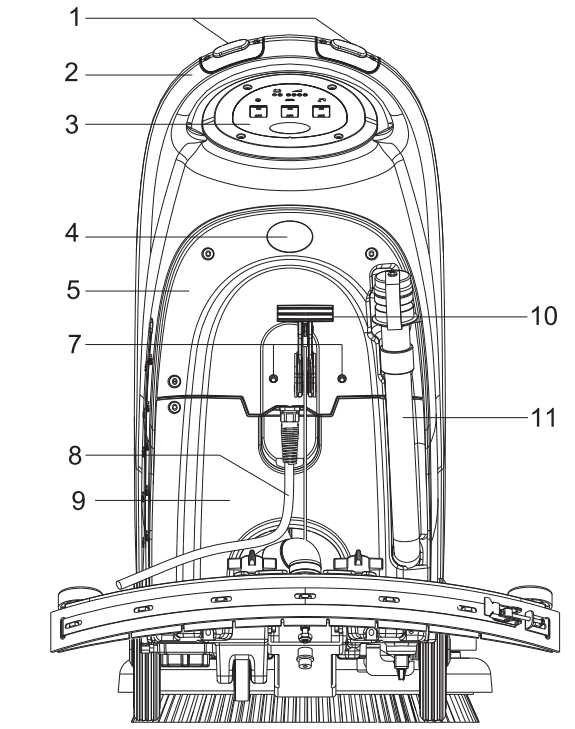

Control System (Corded Model)

Functional Description

The CA30 17E utilizes switch and relay logic for machine control. It receives operator inputs through switches, and activates various solenoids and relays to control components. Most of the components operate at line voltage, except for the scrub switches and scrub control relay, which operate at 24 volts, DC.

Control Panel

The control panel contains the operator controls, including the scrub switches located in the handle of the machine.

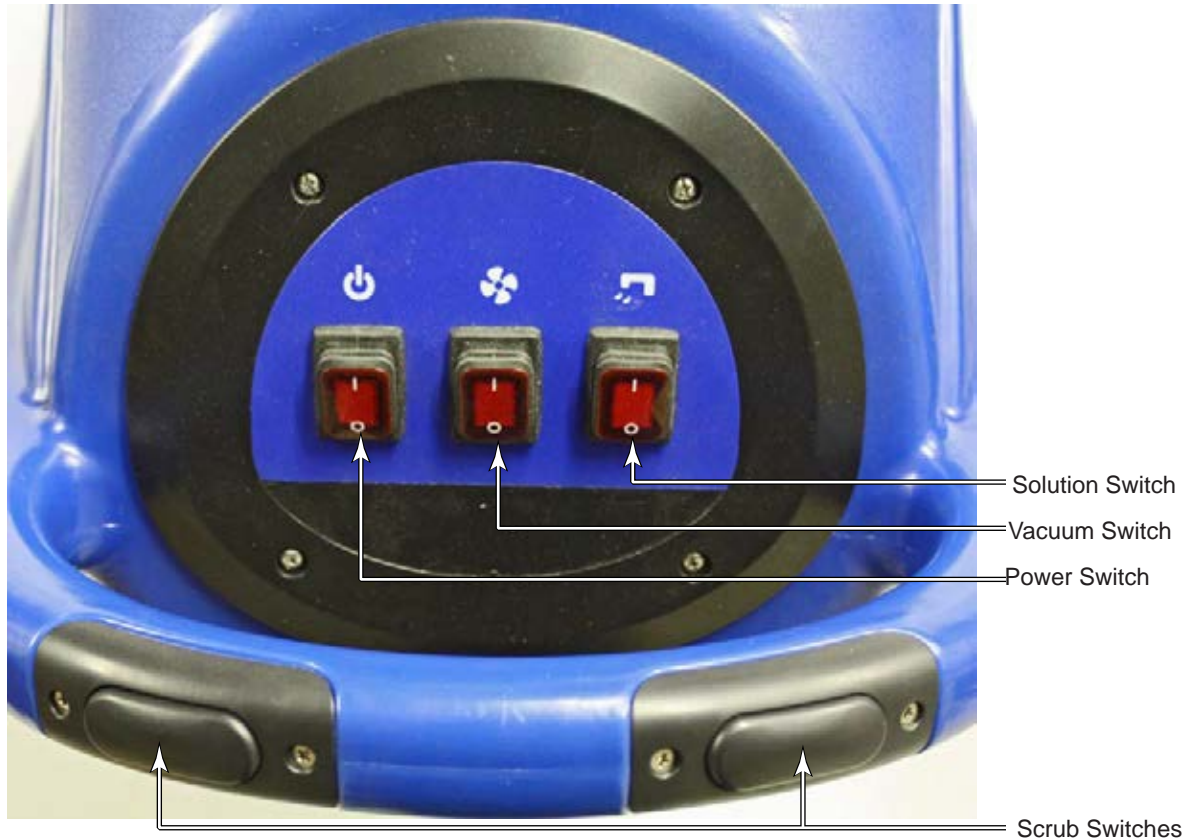

Schematic

The following shows the electrical controls schematic. Each of the functions are further described in the subsequent sections.

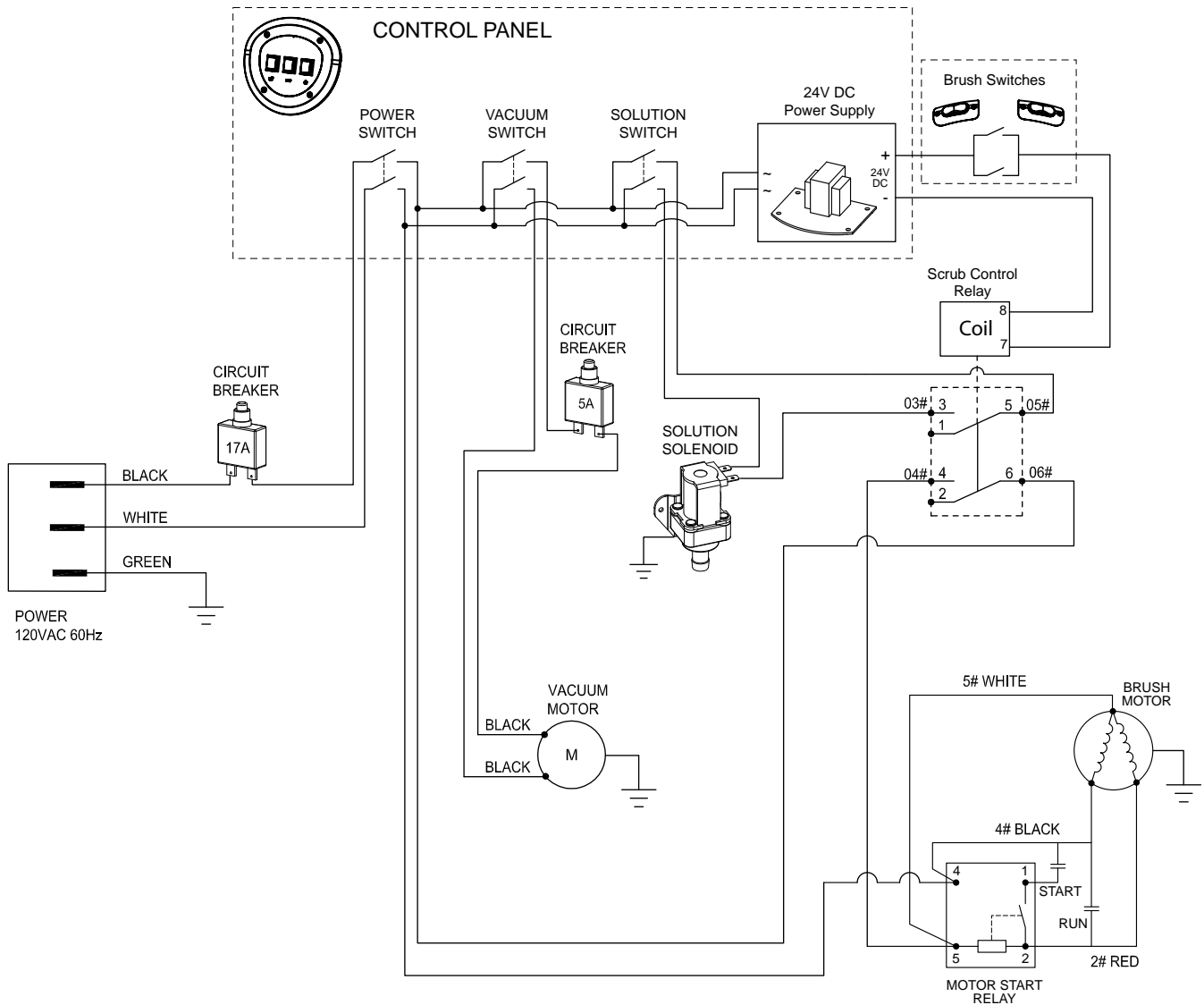

Main Power

The main machine power comes from 120-volt AC mains power. This first passes through a resettable circuit breaker for circuit overload protection. All power to the remainder of the machine passes through the main power switch in the control panel, which switches both line and neutral conductors to the rest of the system. All downstream functions are in series with this circuit breaker and switch.

Vacuum Motor

The vacuum motor receives its power from the main power switch. It too switches both line and neutral conductors. From here, the line-side passes through a resettable circuit breaker to protect the motor, and then directly to the motor. The vacuum motor is a “universal motor”, which means it uses internal carbon brushes for mechanical commutation of the winding polarity.

Solution Solenoid

The solution solenoid is a 120-volt magnetically controlled valve that permits fluid to gravity-flow to the scrub deck. Power to the solenoid first passes through the main power switch, then the solution switch. The neutral conductor passes straight to the solenoid, but the line-side conductor passes through the scrub control relay before going to the solenoid. (See [Scrub Control Relay](#) described on page 15 for a description of the scrub function.) This series connection causes the solution solenoid to be active only if the scrub system is active. No solution will flow unless the brush is also active.

Brush Motor and Starter

The brush motor is a single-phase induction motor with a separate start winding to get the motor up to operating speed. An analogy for this type of motor is the pedals on a bicycle, where the pedals are positioned straight up-and-down, and can't be started until the pedals are moved slightly past-center. The start winding is used to "pull the pedals (motor winding) past center" so normal magnetism can cause complete rotation.

The power through this start winding needs to be slightly delayed (electrically) from the main AC power, which is accomplished with capacitors. When the motor is already running at-speed, the "Run Capacitor" provides sufficient delayed-power to the start winding to keep the motor spinning past this "straight up-and-down" position. However, when the motor is just getting started, it needs a little extra power (extra kick) in the start winding to get moving. This is provided by an additional, larger capacitor, called a "Start Capacitor". During start-up, the Run capacitor and Start capacitor combine to give this extra amperage to the start winding to begin to turn. However, this extra current in the start winding would be too much current when running at normal speed, so the Start capacitor must be disconnected from the motor once it begins to turn near operating speed. This is the function of the "Motor Start Relay".

Motor Start Relay

The motor start relay controls when the start capacitor is connected to the brush motor. The start capacitor needs to be connected during startup, but to prevent too much current in the winding, it must be disconnected once the motor is up to speed. The start relay is a voltage-controlled relay that turns off (normally closed contacts open) once a prescribed voltage has been reached at its coil. This relay senses when the voltage of the Start Winding has reached its operating voltage, and then disconnects the start capacitor.

The most common failure-mode of a capacitor-start, capacitor-run motor is failure to achieve operating speed. Refer to the [Troubleshooting](#) described on page 16, but this is most commonly caused by a failure of the start capacitor.

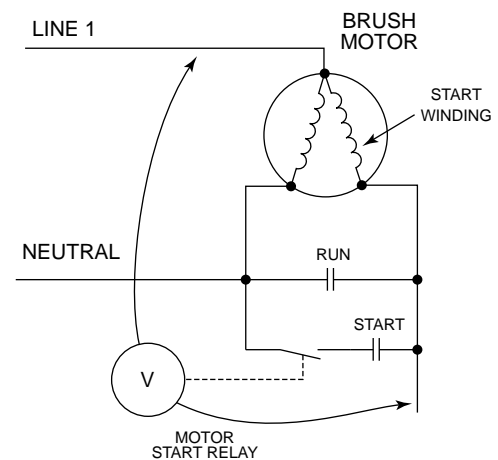

Scrub Control Relay

The scrub control relay permits low-voltage control from the operator’s scrub switches to control both the solution solenoid and the brush motor, while still permitting the operator to control whether the solution system is active or not active when the brush is active.

The scrub control relay is acting as the primary motor contactor for the brush motor, but a second set of contacts also functions to “enable” the solution solenoid circuit. This prevents the solution solenoid from being active when the brush motor is not also active.

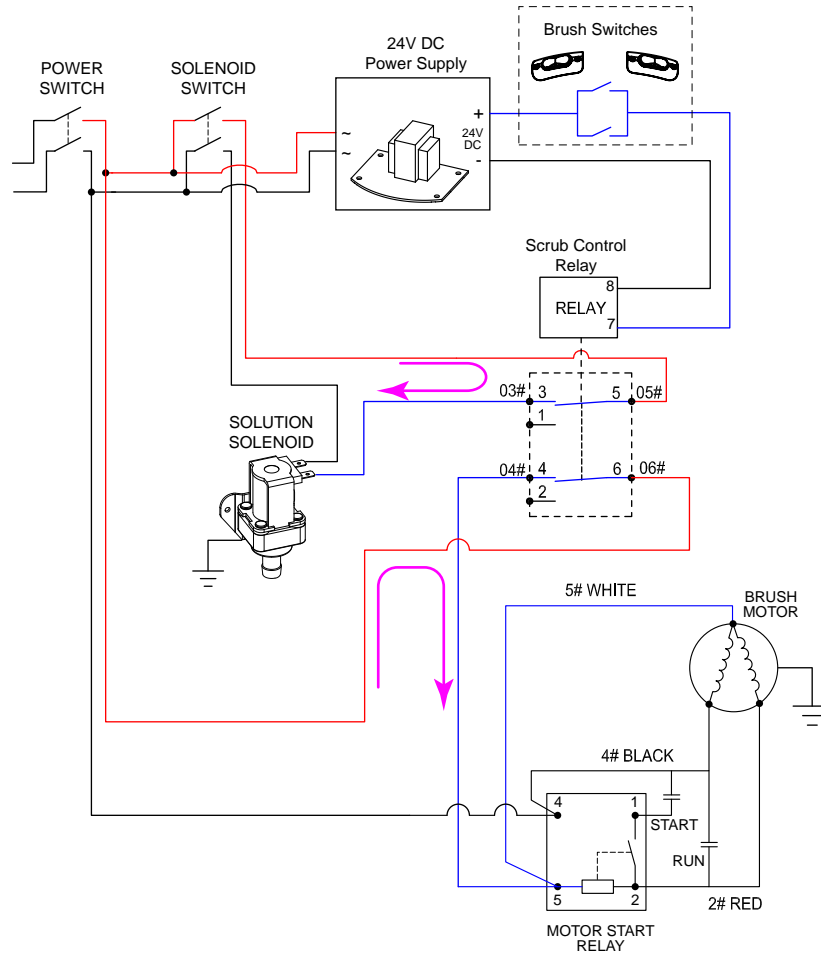

Troubleshooting



Warning! Risk of electrical shock. Some of the procedures below require examining parts of the machine while electrical power is present. Use care when examining or troubleshooting the machine when power is present. Always disconnect power from the machine before and after these examinations are performed.

Whole Machine Not Functioning

If the whole machine is not functioning, it is an indication of a power failure up to and including the main power switch in the control panel. Make the following inspections:

- Verify that facility power is available. If the electrical circuit is protected by a Ground Fault Circuit protection device (GFC/GFCI), make sure the device, such as receptacle or GFCI breaker, has not tripped.
- Inspect the power cord or extension cord for damage and loose, bent, broken prongs.
- Check the machine on-board circuit breaker for trip by pressing in on the button.
- With the power cord removed, remove the control panel and inspect for loose wires at the main power switch, as well as the remaining switches.
- After verifying that no wires are exposed or shorted, carefully plug the machine back in to power and check for full line voltage between L1 and Neutral at both sides of the main power switch when the switch is turned on.
 - If voltage is present at the incoming side but not at the switched side when the switch is in the on-position, replace the switch.
 - If no voltage was present at either pair of switch contacts, inspect the main circuit breaker.

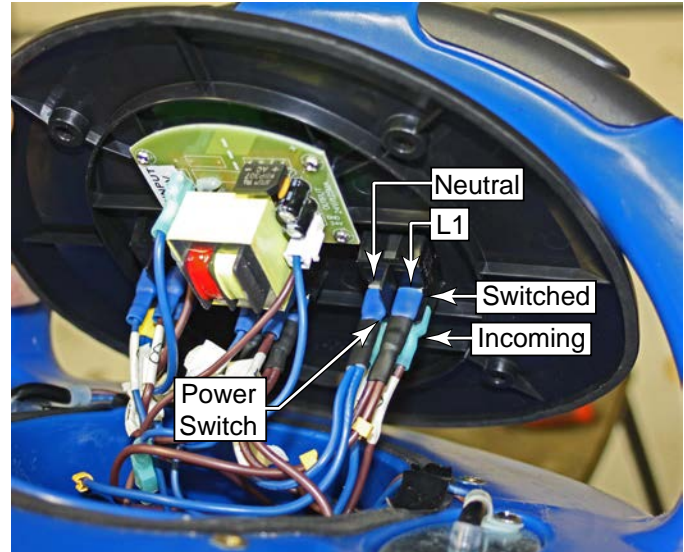

Removal and Installation

Rear Covers (Control Cover)

The rear covers provide access to the motor capacitors and the system relays. Even though the upper and lower covers are separable, it is best to treat them as a single cover during removal and replacement.

1. Unplug the machine from power.
2. (Optional) You may wish to remove the squeegee assembly **(E)**. When the upper cover is removed, the squeegee will no longer be lifted by the lift cable **(F)**.
3. (Optional) If you need to separate the cover from the machine entirely, you will need to remove the squeegee lift cable **(F)**. Remove the bolt **(G)** and remove the cable.
4. Free the recovery drain hose from its clip and lay it to the side.
5. Remove the 6 screws **(C)** that secure the upper **(A)** and lower **(B)** covers to the machine.
 - The 2 screws **(D)** at the top of the lower cover do not need to be removed at this time, but may be removed later if you wish to separate the upper and lower covers.
6. Free the covers from the vacuum and recovery hoses, and remove the covers.

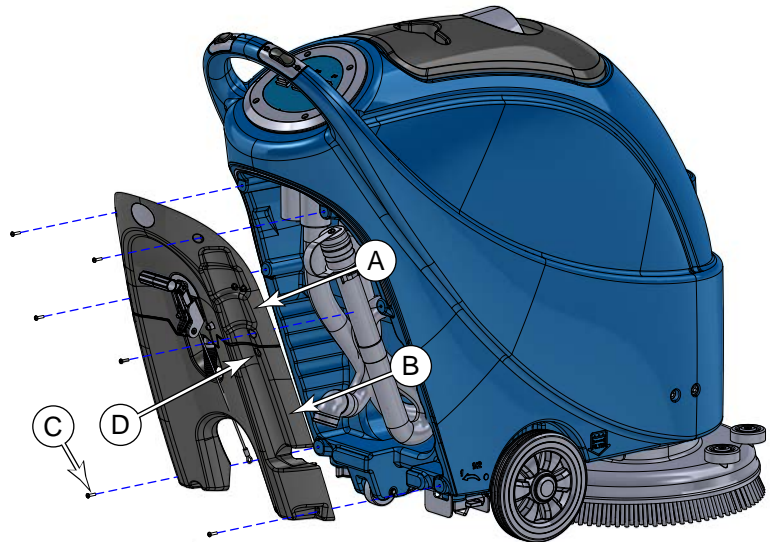
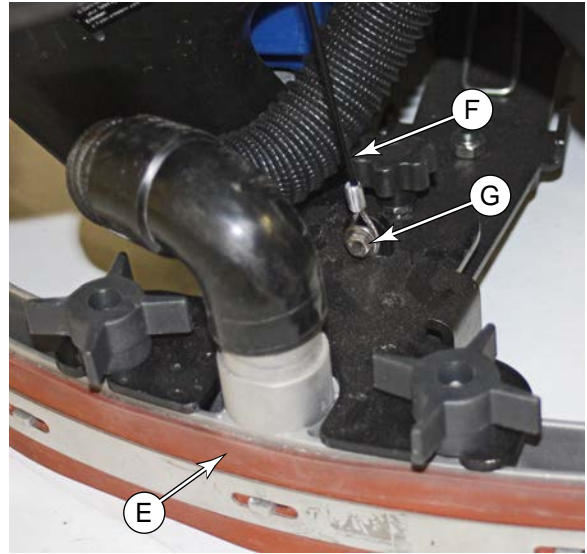

7. To separate the cover from the machine, remove the following wire connectors:
 - Main power **(H)** from main circuit breaker to control panel
 - Main neutral **(I)** from power cord to control panel
 - Ground wire **(J)** from terminal lug
 - Vacuum motor circuit breaker wires **(K)**

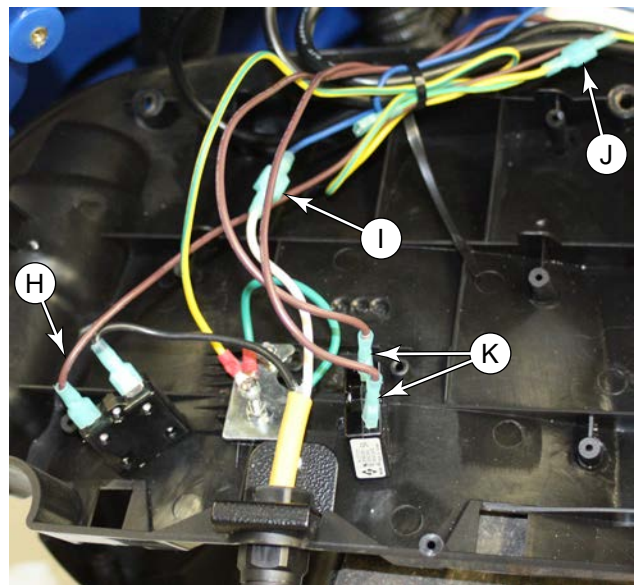

Control Panel

The control panel contains the machine control switches and the DC power supply for the scrub relay. The machine's relays are located below the control panel.

1. Make sure the machine is unplugged from power.
2. Remove the 4 screws **(B)** that secure the control panel **(A)**.
3. Carefully lift the control panel up to expose the wiring below.
4. Remove the 2 AC input wires from the power supply board.
 - The polarity of the wires is not critical to the function of the power supply.
5. Unplug the DC output connector from the power supply.
6. Using tape or similar label, make note of which wiring bundles are connected to each of the 3 switches, and remove the 4 wires from each switch.
 - During replacement, take care not to mix the line and neutral wires on each side of the switch. One side of the switch switches the line-side and the other side switches the neutral-side.
 - **Important:** Reversing these wires will result in a direct short circuit of the 120-volt power.

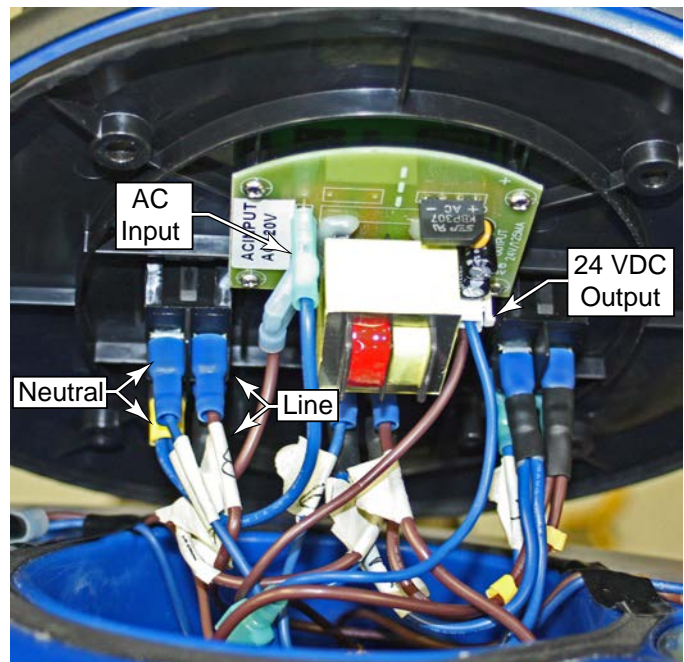
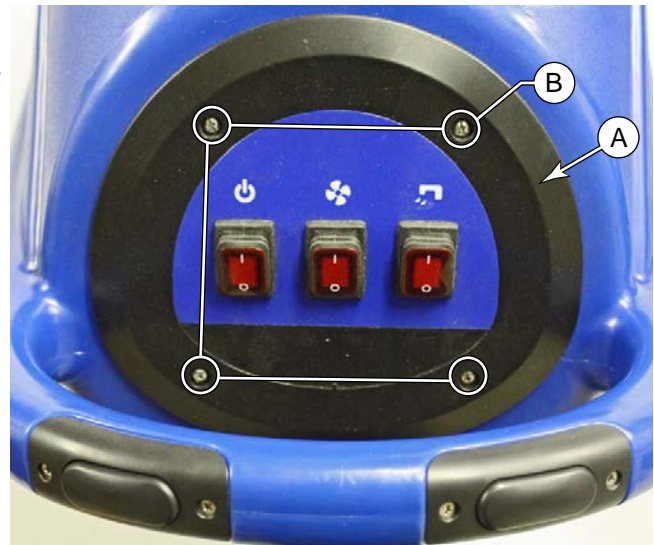

Relays and Brush Motor Capacitors

The relays and brush motor capacitors are located below the control panel, but to access them, they must be removed from below.

1. Remove the [Control Panel](#) described on page 18, and disconnect all of the associated wiring.
2. Disconnect the scrub switches from the scrub relay coil.
3. Remove the [Rear Covers \(Control Cover\)](#) described on page 17.
4. Remove the 2 screws **(A)** that secure the capacitor holder **(B)** to the machine, and carefully lower the assembly and wires out of the machine.

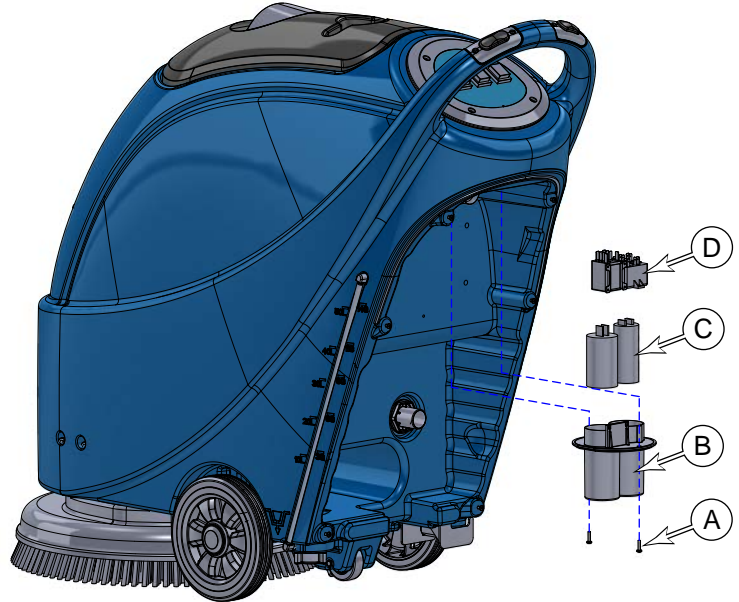

5. Remove the screw **(E)** that secures the motor starter **(F)**.
6. Loosen the 2 screws and nuts **(G)** that secure the scrub relay **(H)**.
7. Simultaneously slide out both capacitors by pushing up on them through the holes in the bottom of the capacitor holder.
8. Before disconnecting any of the wires, make note of their locations for later replacement.

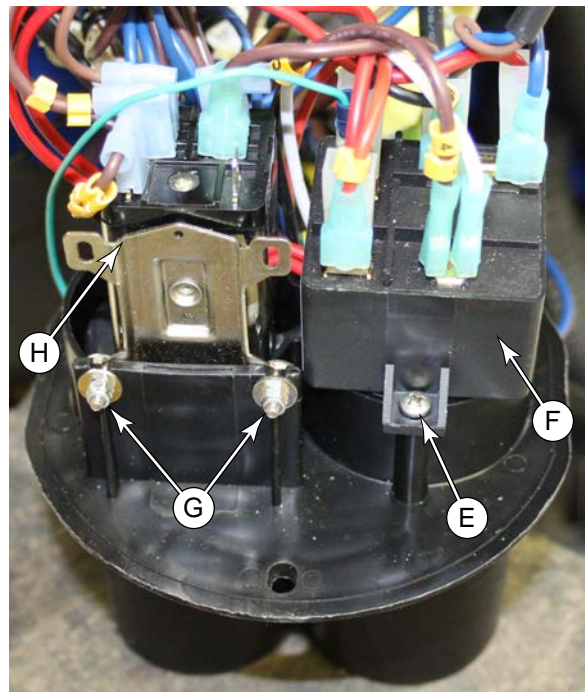

- **(J)** Start Capacitor
- **(K)** Run Capacitor
- **(L)** Start Relay
- **(M)** Scrub Relay

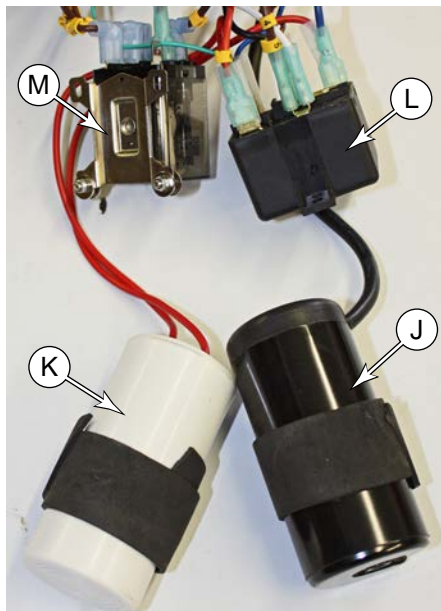

Control System (Battery Model)

Functional Description

The CA30 20B utilizes a main machine controller to turn on various machine functions. It receives operator switch inputs, and activates various solenoids and components. Each of the machine components is described below. Refer to the machine [Schematic](#) on [page 22](#) for details.

Control Panel

The control panel (display) provides the main operator interface for the machine. It provides battery status and contains the switches for operating the machine.

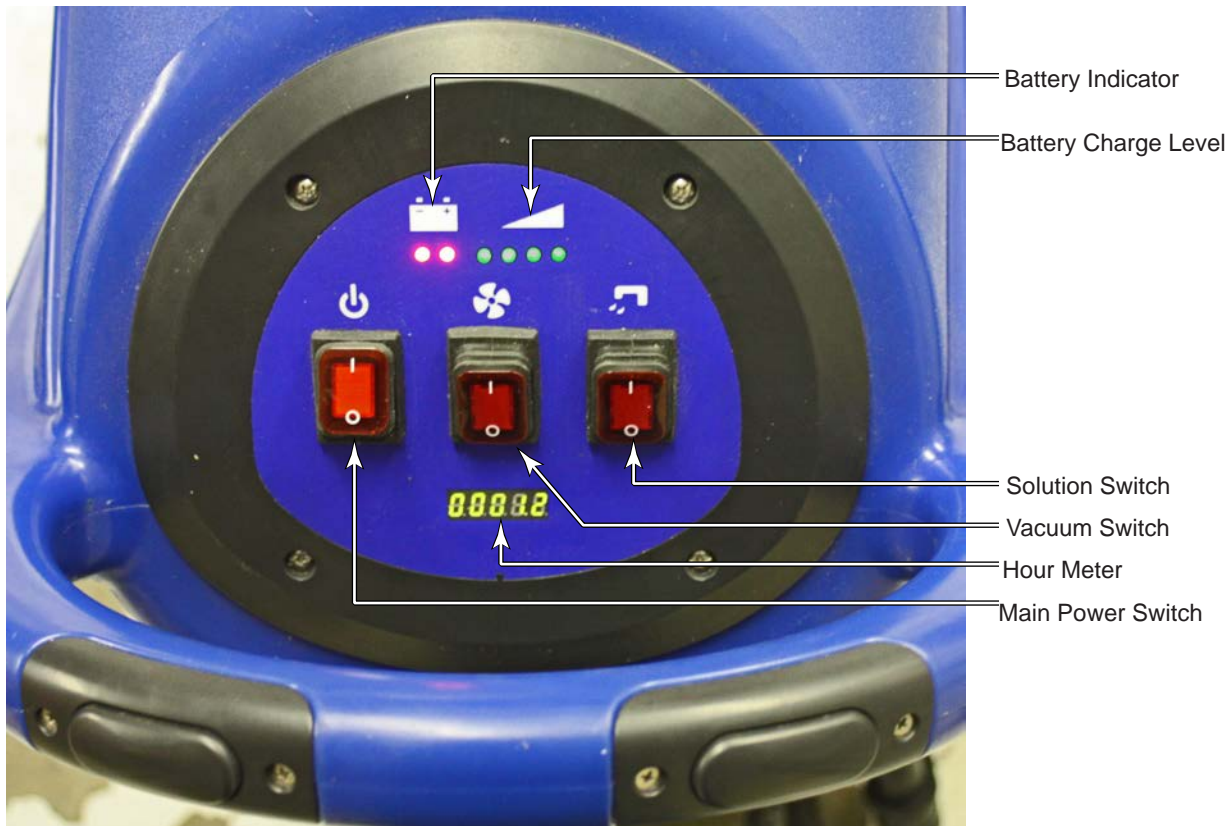

Main Power Switch

The main power switch controls power to the main control board and the hour meter. For the hour meter, both the positive and negative power leads are switched. For the control board, only the negative power lead is switched. Positive power is always present at the control board, but passes through a 30-amp circuit breaker.

This arrangement reduces the total amperage flowing through the main power switch. The power consumed by the brush motor and vacuum motor do not pass through this switch. Only their control signal power passes through this switch. This reduces the likelihood of the switch contacts being damaged by high amperage current flow.

Battery Charger

The battery charger is semi-autonomous, and is always connected to the batteries unless the main battery disconnect is unplugged. The charger is microprocessor-controlled to provide the optimal charge-curve to the batteries depending on the battery type. The battery type, voltage, and max. current is determined by DIP switches inside the charger. The charger also contains a small normally-closed relay that opens whenever the charger is plugged in to building power. This relay serves to notify the machine's control board that the charger is plugged in and active, so that the control board can disable all machine functions while being charged. When the charger is unplugged, the circuit is closed and the machine is enabled. When the charger is plugged in, the circuit is open and the machine is disabled.

Vacuum Motor

The vacuum motor is controlled by a relay built in to the main control board. This relay switches the positive power to the vacuum motor. This is fused through the same circuit breaker that provides power to the control board. The negative power to the motor is unswitched and unfused from the battery.

Solution Solenoid

The solution solenoid is a 24-volt magnetically controlled valve that permits fluid to gravity-flow to the scrub deck. Power to the solenoid comes from a relay on the machine control board. This relay switches the negative power to the solenoid. The solution solenoid is active only when the solution switch is closed, and at least one of the brush switches are closed. This causes the solution solenoid to be active only if the scrub system is active. No solution will flow unless the brush is also active.

Brush Motor

The brush motor is controlled by a power relay adjacent to the control board. The positive power to the motor passes through the second 30-amp circuit breaker. This circuit breaker serves only the brush motor. The negative power to the motor is switched by the brush relay. Both positive and negative power to the relay coil comes from the machine control board.

Vacuum, Solution, and Brush Switches

These switches are low-power control signals to the machine control board. They share a common positive lead from the control board, and return that positive signal back to the control board when closed. The two brush switches are in parallel, so that if either switch is closed, the circuit is completed.

Hour Meter

The hour meter is a simple clock that receives power from the main power switch, but is enabled only when the scrub switches are closed.

Battery Meter LEDs

The battery meter LEDs are controlled by the main control board based on the voltage of the battery. Each successive LED turns on at a higher voltage level, depending on the position of the Wet/Gel DIP switch. The operating voltage range of a wet battery is lower than a gel battery, so the LEDs will turn on at lower voltage for wet versus gel batteries. When the battery is fully depleted, the 2 red LEDs will flash, and the machine will shut down.

Schematic

The following shows the electrical controls schematic.

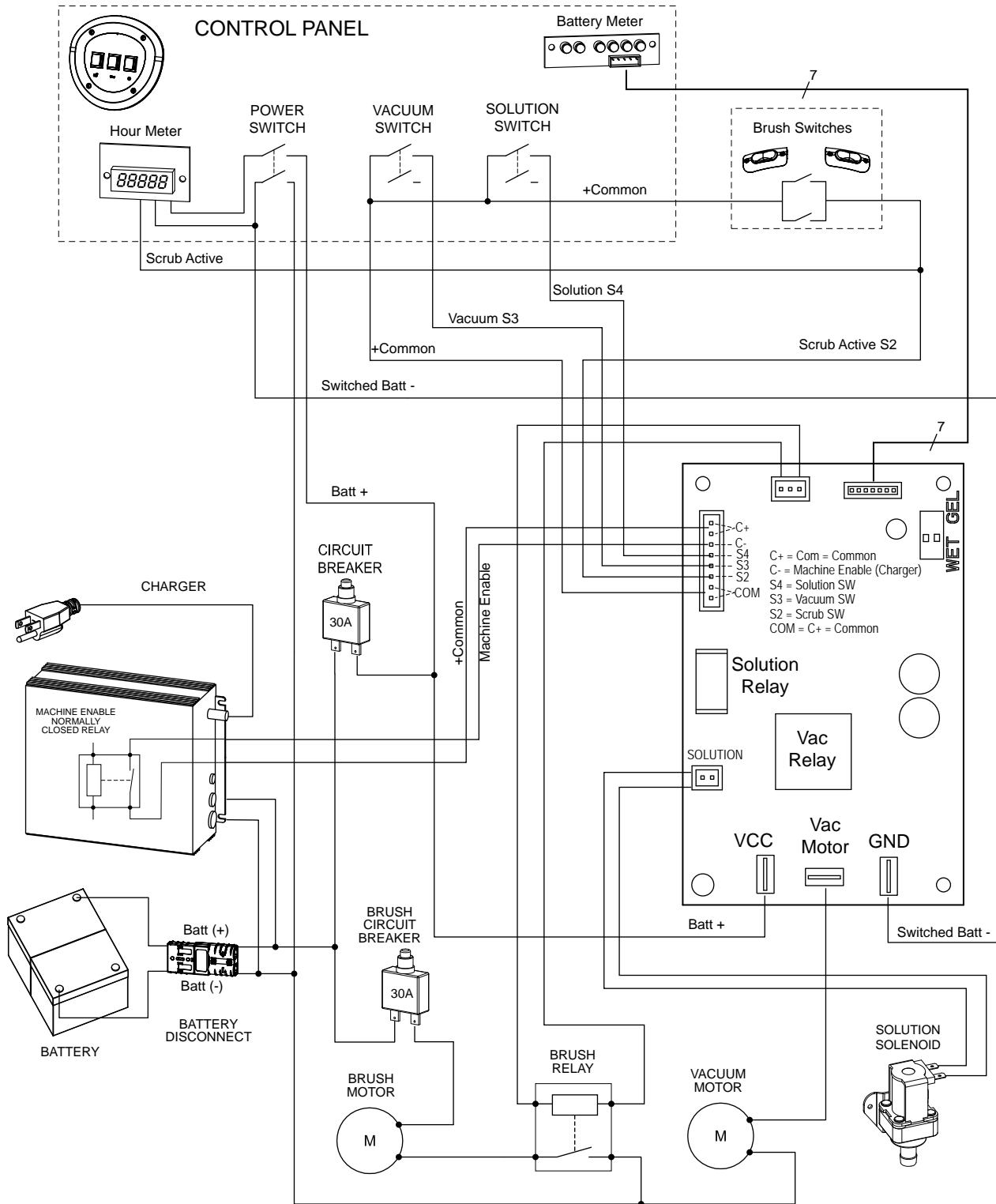

Troubleshooting

The following sections present some common troubleshooting scenarios based on symptoms.

Whole Machine Not Functioning

The symptom of “whole machine not functioning” means that the vacuum motor does not run, brush motor does not run, and solution solenoid does not engage. If the whole machine is not functioning, it is an indication of a power failure, control board failure, or a battery charger failure. Make the following inspections:

1. Make sure the battery charger is not plugged in to building power. The machine is disabled when plugged in to power.
2. Turn on the main power switch and observe the lights on the control panel. During normal operation, the following should take place:
 - If present, the hour meter will illuminate immediately.
 - The two red LEDs below the battery icon will illuminate for about 1 second.
 - When the red LEDs turn off, the green battery level LEDs will turn on.
3. If the hour meter does not illuminate, then power is not reaching the main power switch. Check the following:
 - Make sure the battery disconnect plug is firmly connected.
 - Make sure the circuit breaker labeled “Vacuum” is not tripped by pressing in on the button.
 - Remove the [Rear Covers \(Control Cover\)](#) described on page 26 and begin checking voltages, starting at the main power switch and working back toward the batteries.
4. Unplug the battery disconnect and measure the battery voltage to ensure the batteries are not fully depleted. Reconnect the plug when done.
5. If the red LEDs below the battery icon do not illuminate for 1 second during startup (and the batteries are not depleted), then it is likely that the control board is not getting power or the control board is faulty.
 - With the main power switch on, check the voltage between VCC and GND at the top of the control board. If power is present, then the main control board is faulty and needs to be replaced.

Machine Enable Circuit

6. If the red LEDs illuminate but the green LEDs do not illuminate (and the battery voltage measured above is not depleted), then it is likely that the controller believes the machine is being charged.
 - Inspect the 2 machine enable wires between the control board (S2 and COM) and the charger for breaks or an open circuit. An open circuit on these wires will disable the machine as though it was being charged.
 - Measure the voltage between these two wires as you cycle the machine power switch and cycle the battery charger power, and compare the results to the table data on [page 24](#).

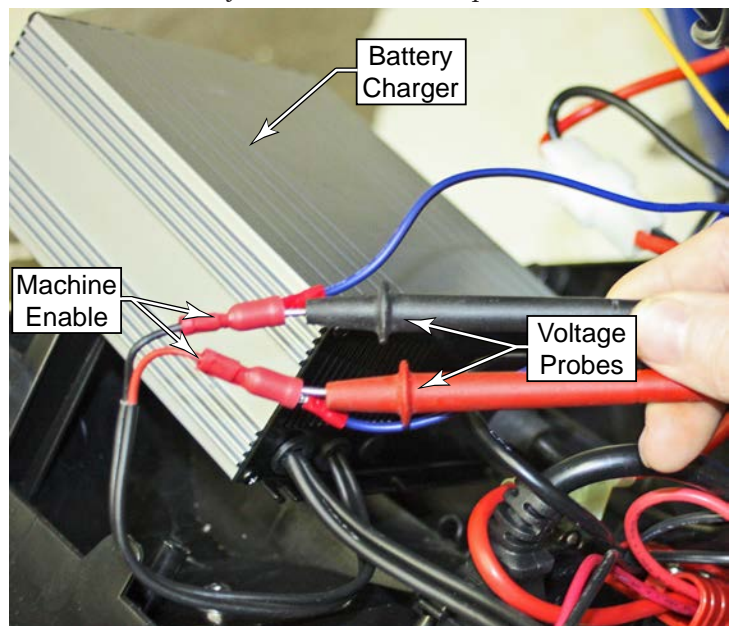

| Charger and Power Switch Status | Voltage between Machine Enable and +Com | | | | Charger relay resistance w/o control board ‡ |
|---------------------------------|---|----------------------------|-------------------------|-----------------|--|
| | Normal | Open circuit at Controller | Open circuit at charger | Short Circuit † | |
| Charger = off Power = off | 0 V | 0 V | 0 V | 0 V | 0 Ω (short) |
| Charger = off Power = on | 0 V | 0 V | 24 V | 0 V | N/A |
| Charger = on Power = off | 0 V | 0 V | 0 V | 0 V | ∞ Ω (open) |
| Charger = on Power = on | 24 V | 0 V | 24 V | 0 V | N/A |

† Column-4, Short Circuit isn't specifically applicable to the scenario because the machine would be functioning. However, the machine would also be fully functional when the charger was plugged in.

‡ **Important:** To avoid damaging your multimeter, make sure to disconnect the control board before checking the resistance of the charger relay contacts. Leave the machine turned off.

- The **Red** entries in the table above are the measurements that are indicative of the associated failure modes.
- If all of your measurements show 0 volts (columns 2 and 4 above), turn the machine power off, disconnect the wires, and measure the resistance of the relay contacts in the charger with the charger unplugged and then plugged in. Compare these to the results in the last column of the table above.
- Briefly jumper the two wires together and turn the machine on. If the machine functions normally, then the battery charger is faulty and needs to be replaced.

Power, Vacuum, Solution, and Brush Switches

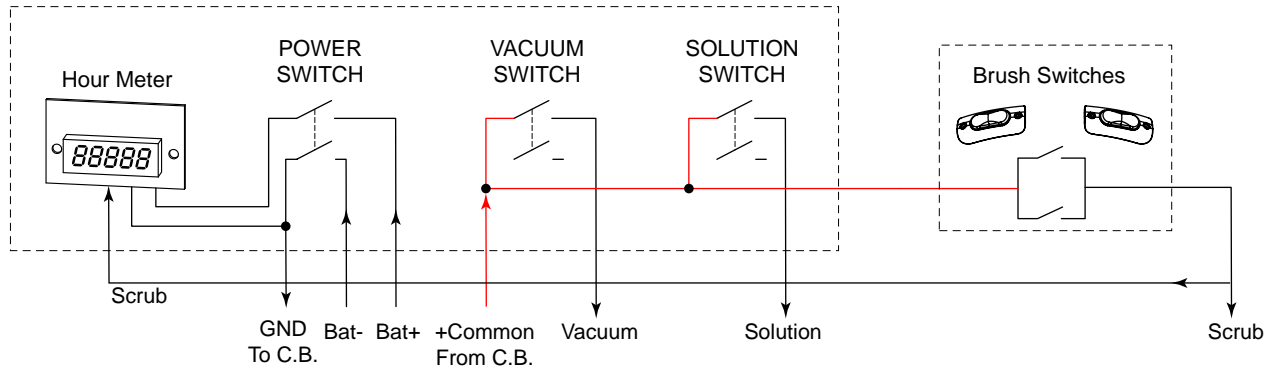

Checking the function of the switches in the operator's control panel is typically required for other troubleshooting procedures. The main power switch provides the negative power (GND) to the control board. So nearly all troubleshooting procedures rely on verifying the function of the main power switch. The remaining switches use a shared positive power (+Com) from the control board, which should also be checked.

1. Verify incoming battery power at the main power switch (24V between terminals).
 - Note that these switch terminals will provide convenient battery +/- reference test points for the remaining examinations.
2. Verify outgoing power at main switch. Terminal-to-terminal should be 0 volts when the switch is off, and 24 volts when the switch is on.
3. Verify that the control board is providing +Com at the vacuum, solution, and brush switches.
 - When main power switch is on, voltage between Bat- and +Com should be the same as battery voltage.
 - When the main power switch is off, the voltage between Bat- and +Com should be 0 volts.
4. Verify the outgoing power from the vacuum, solution, and brush switches.
 - When the switch is off, the voltage between Bat- and the wire leading to the control board should be 0 volts.
 - When the switch is on, the voltage between Bat- and the wire leading to the control board should be 24 volts.

Removal and Installation

Rear Covers (Control Cover)

The rear covers provide access to the control board, brush relay, batteries, and battery charger. Even though the upper and lower covers are separable, it is best to remove them as a single cover.

1. Unplug the machine from power.
2. (Optional) You may wish to remove the squeegee assembly **(E)**. When the upper cover is removed, the squeegee will no longer be lifted by the lift cable **(F)**.
3. (Optional) If you need to separate the cover from the machine entirely, you will need to remove the squeegee lift cable **(F)**. Remove the bolt **(G)** and remove the cable.
4. Free the recovery drain hose from its clip and lay it to the side.
5. Remove the 6 screws **(C)** that secure the upper **(A)** and lower **(B)** covers to the machine.
 - The 2 screws **(D)** at the top of the lower cover do not need to be removed at this time, but may be removed later if you wish to separate the upper and lower covers.
 - During reassembly, you may find it easier to install the covers separately. Install the upper cover first.
6. Free the covers from the vacuum and recovery hoses, and remove the covers.

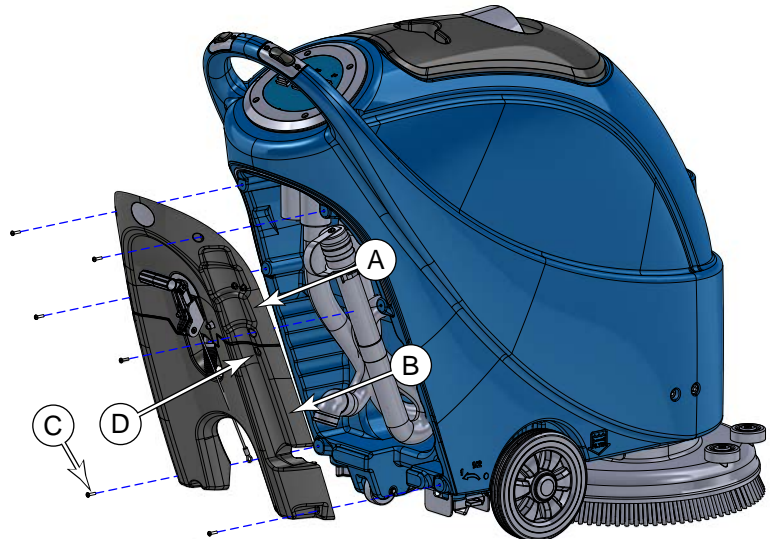
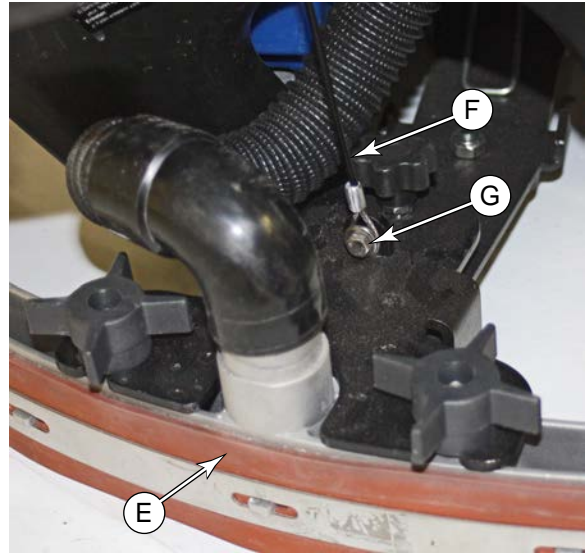

7. To separate the cover(s) from the machine, remove the following wire connectors and tethers:
 - Brush motor power **(H)**
 - Vacuum motor power **(I)**
 - Control board power wires **(J)**
 - Machine enable wires **(K)** from battery charger
 - Main battery disconnect **(L)**
8. Remove the screw from each of the 3 support cords (tethers).

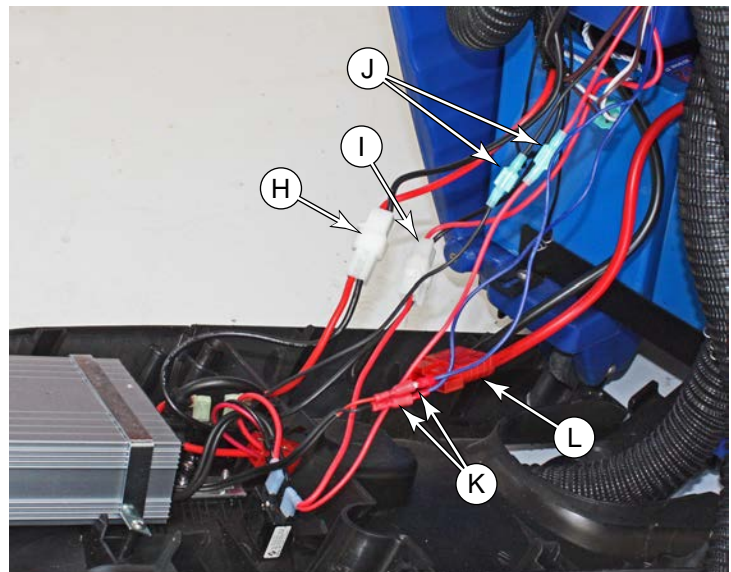

Control Panel

The control panel contains the machine control switches, battery indicator LEDs, and the optional hour meter.

1. Disconnect the main battery connector.
2. Remove the 4 screws **(B)** that secure the control panel **(A)**.
3. Carefully lift the control panel up to expose the wiring below.

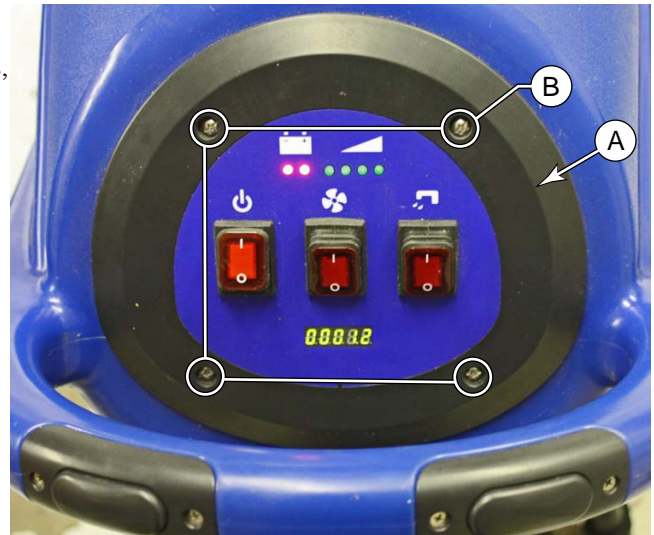

4. Remove the battery meter connector from the battery meter circuit board.
5. Using tape or other label, make note of which wiring bundles are connected to each of the 3 switches, and remove the wires from each switch.
 - During replacement, take care not to mix the positive and negative wires on each side of the main power switch.
6. Unplug the 3 wire terminal lugs from the hour meter.

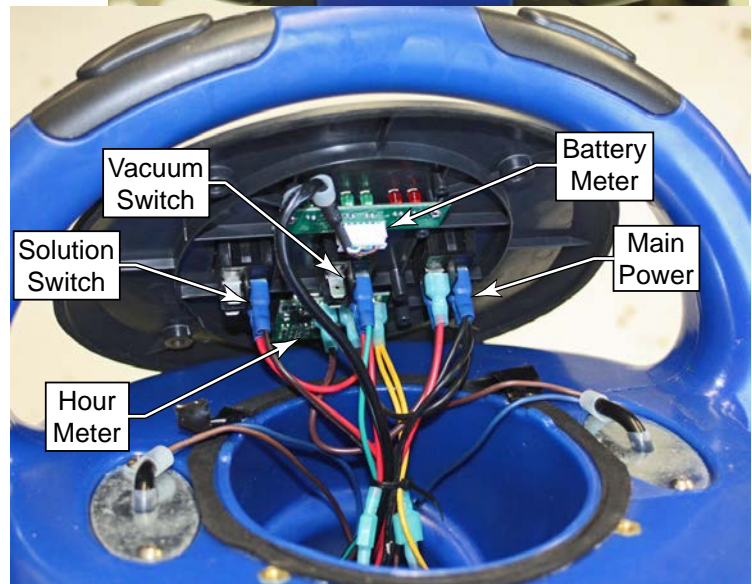

Control Board

Brush Motor relay

The control board is located between the recovery and drain hoses behind the upper rear cover of the machine. The brush motor relay is attached to the control board enclosure. The two procedures are interrelated.

1. Remove the [Rear Covers \(Control Cover\)](#) described on page 26.
 - Make sure to unplug the main battery disconnect during the procedure.
2. Remove the 4 screws **(B)** that secure the control board enclosure to the machine.

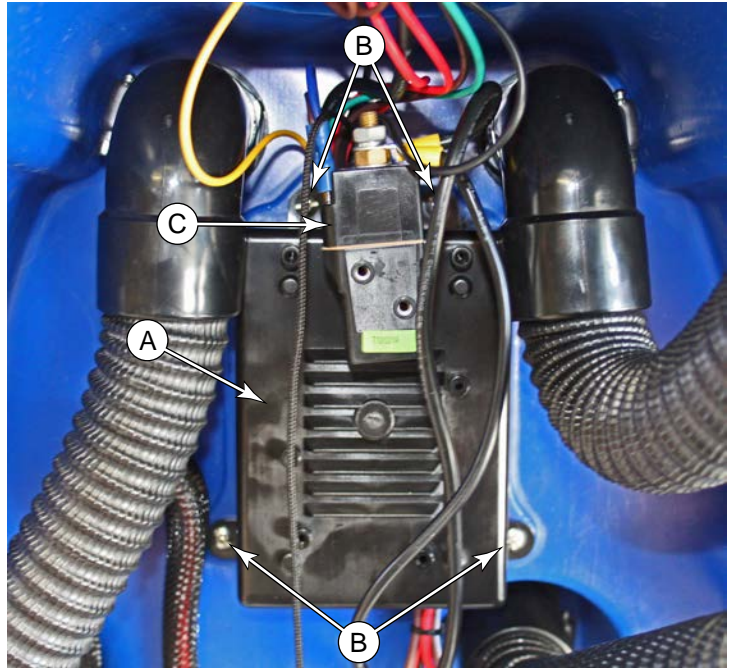

3. Carefully move the control board away from the machine enough to reach the electrical connections on the back side. Remove the following connectors:
 - Main power negative/ground **(D)**
 - Main power positive **(F)**
 - Vacuum motor positive **(E)**
 - Solution solenoid **(G)**
 - Operator switches **(H)**
 - Brush motor relay coil **(I)**
 - Battery level LED board **(J)**

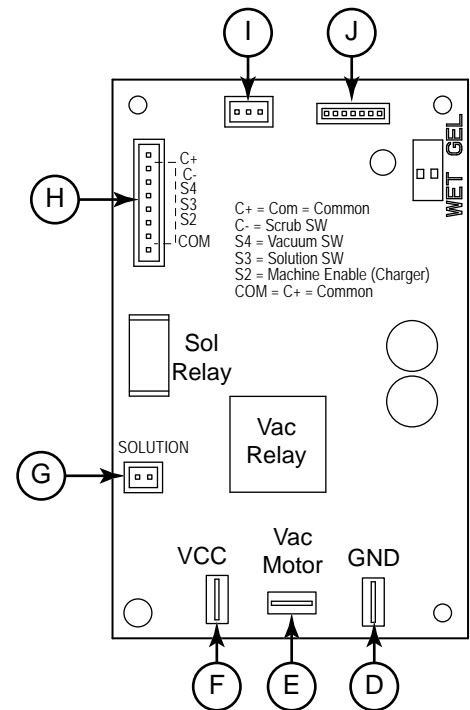

4. Remove the 2 coil wires (**K**) from the brush relay (**M**).
5. Remove the two power wires (**L**) from the brush relay.

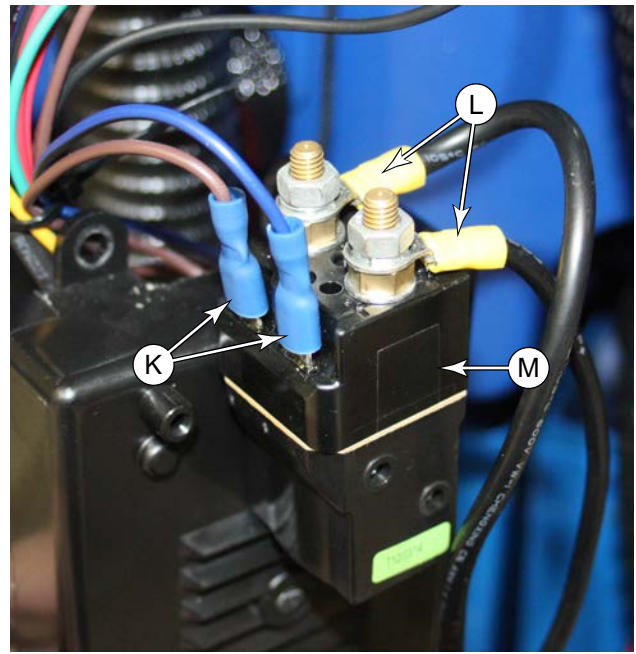

6. Remove the 4 screws (**Q**) that secure the control board (**P**) to the enclosure (**A**), and remove the control board.
7. Remove the 2 screws (**N**) that secure the brush relay (**M**) to the enclosure, and remove the relay.

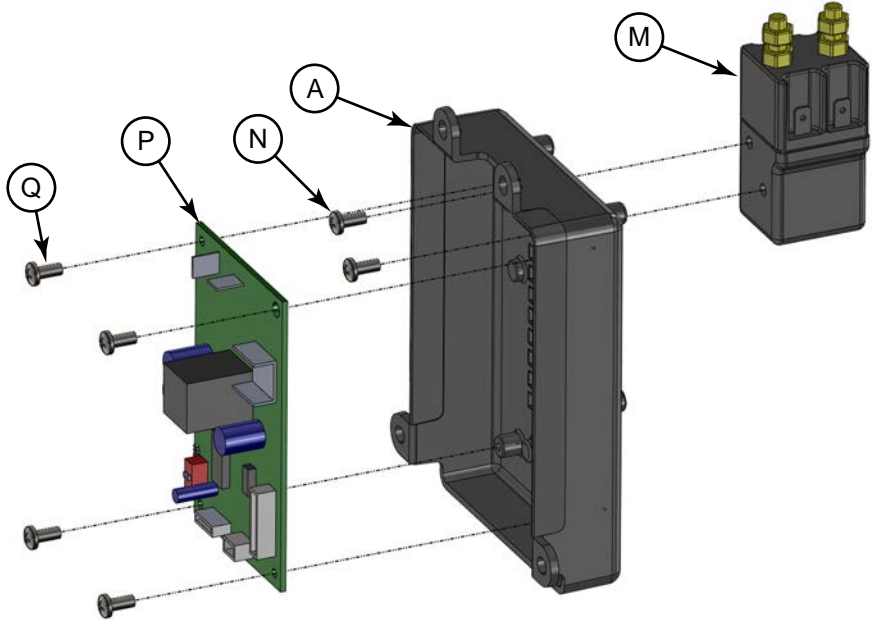

Batteries



Caution: Care must be taken to avoid shorting the battery terminals or battery wires. Never rest tools on top of the batteries, as they can contact and short across the battery terminals.

1. Remove the Squeegee Assembly.
2. Remove the [Rear Covers \(Control Cover\)](#) described on page 26.
 - For battery access, only the lower cover need be removed. Remove the 2 screws marked **(D)** in the procedure.
 - Remove the squeegee lift cable **(F)** in the procedure.
 - Unplug the main battery disconnect in the procedure.
3. Route the vacuum hose **(A)** and recovery drain **(B)** through the operator's handle to keep them out of the way during the procedure.

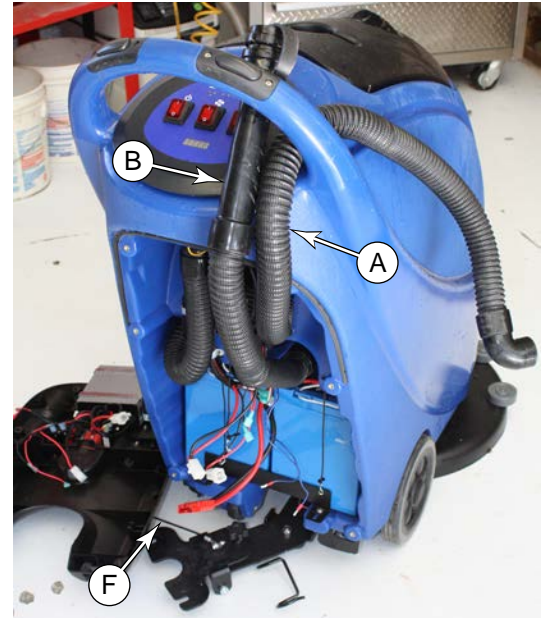

4. Remove the 2 screws **(C)** that secure the battery retaining bracket **(E)**, and remove the bracket.

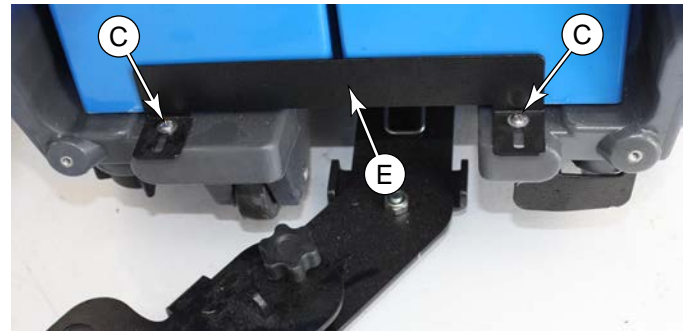

5. Position a platform or lift **(G)** in back of the machine that matches the height of the battery compartment.
6. Simultaneously slide both batteries **(H)** out of the machine and onto the lift.
 - The batteries are not mechanically joined, but they are connected by the rear battery cable, and must be moved together.

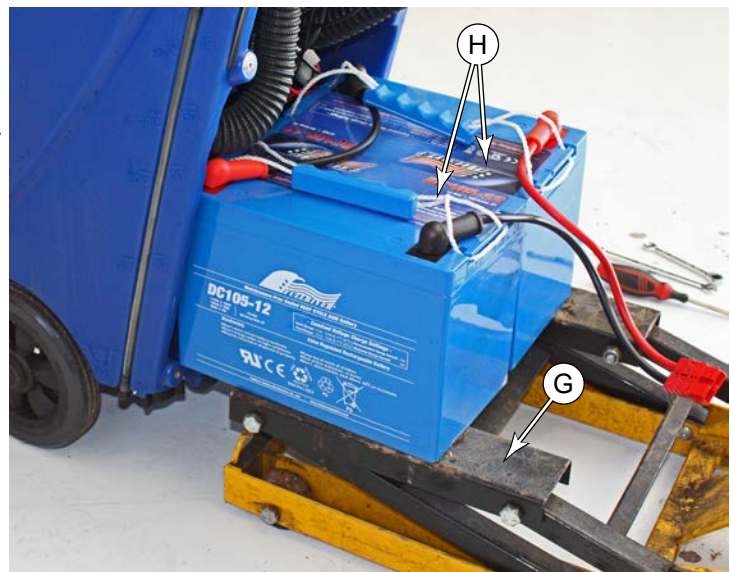

Make sure the replacement batteries fit the machine. They may be either wet-type, AGM-type, or Gel 12-volt batteries, but AGM is preferred. The original batteries are:

- L:307 x W:169 x H:211 mm

The machine maximum capacity is:

- L:330 x W:170 x H:260 mm
- L:13.0 x W:6.7 x H:10.25 in.

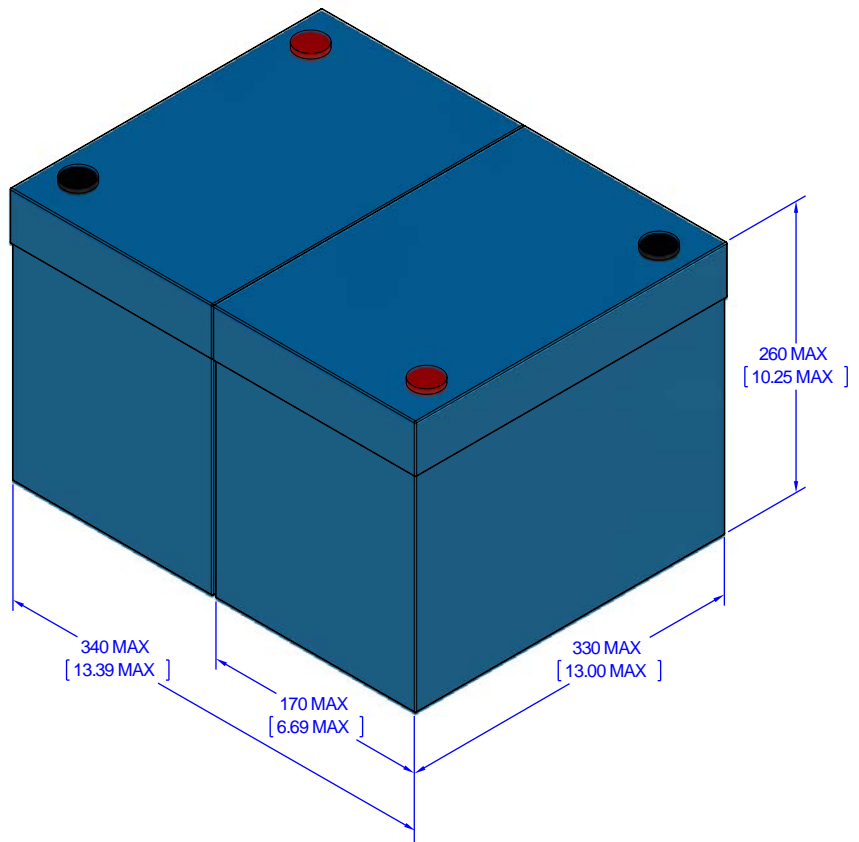

Caution: Care must be taken to correctly connect the battery cables to avoid damaging the machine or the batteries.

7. Slide the protective boots (I) off of each terminal.

8. For easier access, you may temporarily remove the carrying handles (J).

9. Remove the terminal bolts and transfer the rear jumper (K) from the old batteries to the new batteries. Make sure to connect this from positive to negative between the two batteries.

- Torque the terminal bolts to:
7.1-8.0 ft-lbs, 85-95 in-lbs, or 9.6-10.7 N•m

10. Remove the terminal bolts and transfer the battery cable (L) from the old batteries to the new batteries. Make sure to connect this from positive to negative between the two batteries.

- Torque the terminal bolts to:
7.1-8.0 ft-lbs, 85-95 in-lbs, or 9.6-10.7 N•m

11. To verify proper connection of the battery cables, check the voltage at the battery disconnect connector (L). The voltage should be nominally 24 volts. If not, recheck the cable connections.

12. Slide the protective boots (I) back over the terminals.

13. Replace the carrying handles if they were removed.

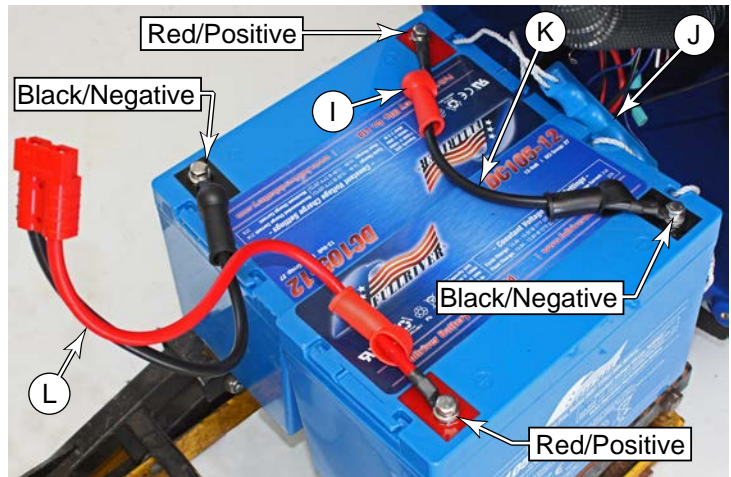

Because the machine is frequently tilted, it is important that the batteries fit properly front-to-rear to prevent them from moving during machine use. For batteries that are less than the maximum size, 24 mm spacers are used to fill the space in front of the battery.

- For batteries less than 310 mm (12.25 in) long, use 1-24mm spacer
 - For batteries less than 285 mm (11.25 in) long, use 2-24mm spacers
14. As needed, place 0, 1, or 2 spacer bars **(M)** against the forward wall of the battery bay **(N)**.
 15. Slide the batteries into the battery bay until they are pressing against the forward wall **(N)** or spacer **(M)**.
 16. Reinstall the battery retaining bracket **(E)**.
 17. If the battery type has not changed, finish the reassembly. Otherwise complete the procedure below to set the battery type.

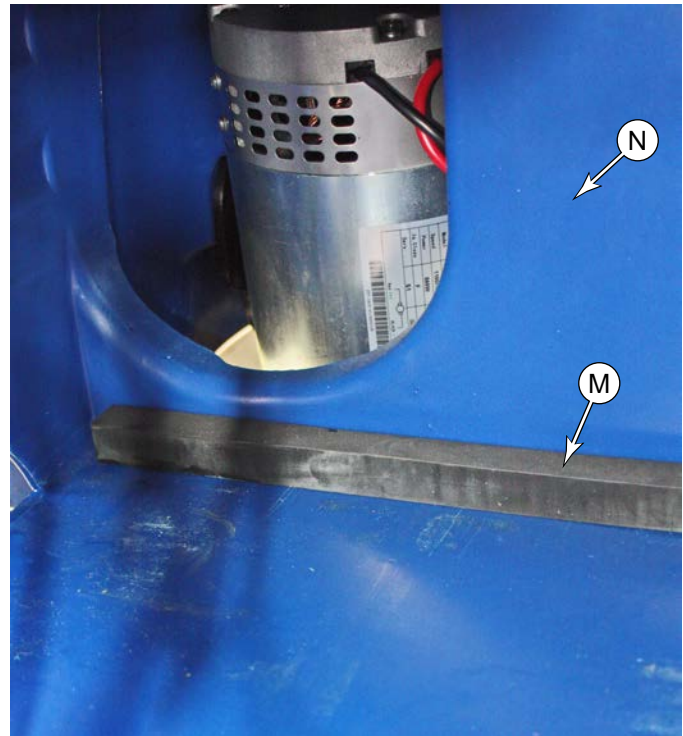

Setting AGM/Wet Battery Type

The battery charger uses different charging curves, depending on the battery type. This is controlled by a dip-switch setting in the charger. Additionally, the battery level LEDs on the control panel will function differently for the different battery types. This is controlled by a dip-switch setting on the control board.

1. Complete the procedure to remove the [Battery Charger](#) described on page 33. The end of the procedure contains the settings for the charger's dip-switch settings.
 - It is not necessary to disconnect any wires from the charger. Just free the charger from the rear cover to access the dip-switches.
2. Remove the control board enclosure as described on [page 28](#), but it is not necessary to unplug any wires.
3. The dip-switches are located at the bottom-left corner of the control board. Move both switches to either "Wet" or "GEL", as necessary. (Use "GEL" for AGM batteries.)

Battery Charger

The battery charger is located on the inside of the rear cover, and is connected directly to the batteries. The charger is microprocessor controlled and uses different charging curves for optimal performance for different battery types.

1. Remove the [Rear Covers \(Control Cover\)](#) described on page 26.
2. Disconnect the cable connector (D) leading to the batteries.
3. Disconnect the two wire terminals (E) leading to the control board.
4. Remove the 4 screws (B) that secure the mounting straps (C) to the cover, and remove the charger (A).

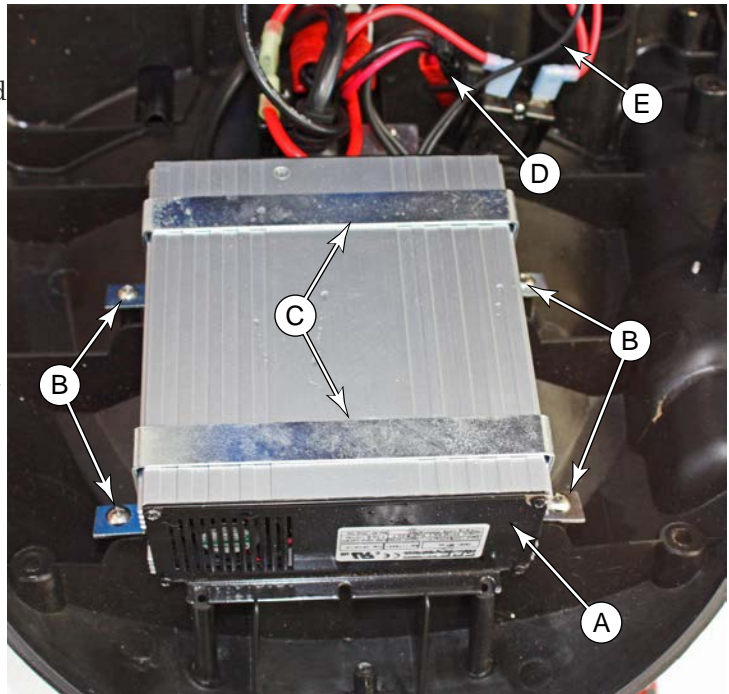

Battery Type Dip-Switches

The charger’s functions are controlled by 4 dip-switches (2-pair) inside the back cover. The second 2 switches should never be touched unless the charger has been replaced and their position needs to be confirmed. They set the battery voltage (24V) and maximum amperage (10A), and should always be in the Off position.

The first 2 switches are accessible through a plastic plug without opening the charger. These switches set the type of charge curve used for each type of battery. The curve type signifies the manner and magnitude in which current and voltage are applied to the battery during its distinct phases of the charge cycle.

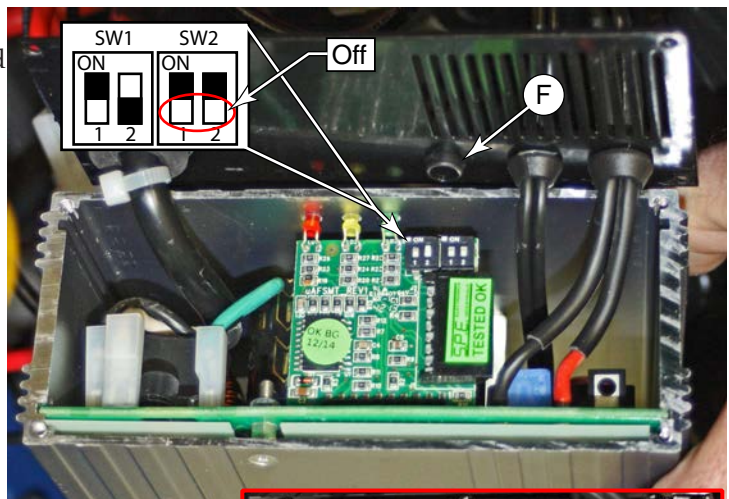

1. Only if the charger is new and the 2nd pair of DIP switches need to be confirmed, is it necessary to remove the rear cover.
2. Remove the plastic plug covering the DIP switch access hole (F).
3. Set the first 2 DIP switches according to the table data below.
4. Replace the plastic plug.

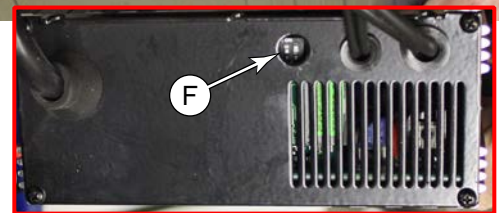

| Battery Type/Brand | Curve Type | SW1 | | SW2 | |
|---|------------|-----|-----|-----|-----|
| | | D1 | D2 | D1 | D2 |
| Lead-acid (Wet) batteries | IUIa-ACD | On | Off | Off | Off |
| Gel batteries, Exide-Sonnenschein | IUIa-GEL | Off | Off | | |
| HAZE Gel and Most AGM batteries (Default) | IUUO-GEL | Off | On | | |
| Discover AGM batteries | IUIUa-GEL | On | On | | |

Specifications

Shop Measurements

The following table represents actual machine voltage measurements. Because battery voltage will vary with level of charge, those values within 0.1 volts of the current battery voltage are listed simply as “B+”.

Taking a measurement between VCC and GND terminals when the main power switch is on will establish your current battery voltage (B+).

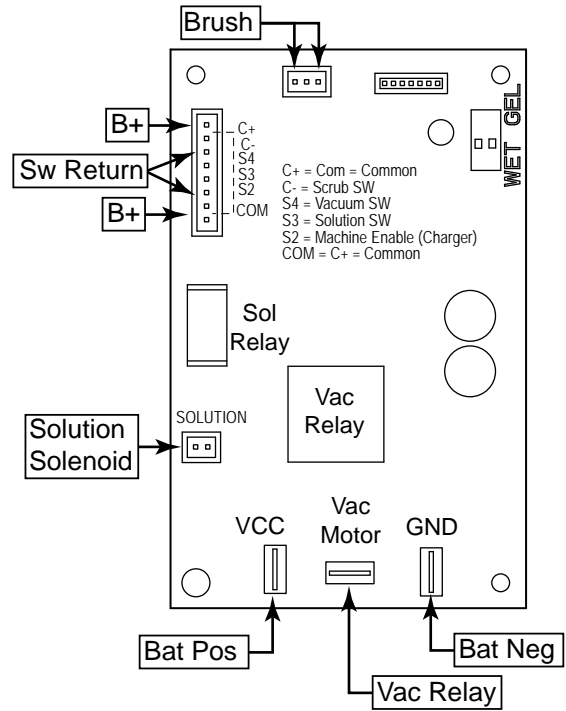

| Test Point | Reference Point | Active | Inactive | Comment |
|---------------------|-----------------|--------|----------|-------------------------------------|
| Vac Relay | GND | B+ | 0V | Active-high |
| Solution Solenoid | Itself | B+ | 0V | Active-high, polarity not important |
| Com, C+ | GND | B+ | B+ | Always active power to switches |
| S2, Machine Enable | GND | B+ | 0V | See page 23 |
| S3, Solution Switch | GND | B+ | 0V | Active-high switch return |
| S4, Vacuum Switch | GND | B+ | 0V | Active-high switch return |
| C-, Scrub Switches | GND | B+ | 0V | Active-high switch return |
| Brush Relay | Itself | B+ | 0V | Active-high, polarity not important |

Recovery System

Functional Description

The purpose of the recovery system is to remove water from the floor. The vacuum motor creates negative pressure in the recovery tank by sucking air out of the tank through the vacuum suction hose. To protect the vacuum motor from ingesting water, a ball float is located at the end of the vacuum suction hose inside the recovery tank. When the tank's water level reaches the float ball, the ball rises until it blocks the inlet of the suction hose.

The negative pressure inside the recovery tank (not shown) causes air/water to be drawn in through the squeegee suction hose. The recovery tank serves to isolate the air/water stream in the squeegee suction hose from the air-only stream in the vacuum suction hose. The water and debris drawn in through the squeegee suction hose falls out of the stream into the bottom of the recovery tank. A separate tank drain hose is used to drain this water and debris from the tank.

The squeegee suction hose draws air/water from the squeegee assembly. The squeegee consists of two squeegee blades: a forward, notched blade, and a rear scraping blade. The notched blade permits water to pass into the space between the two blades, where it is drawn into the suction hose.

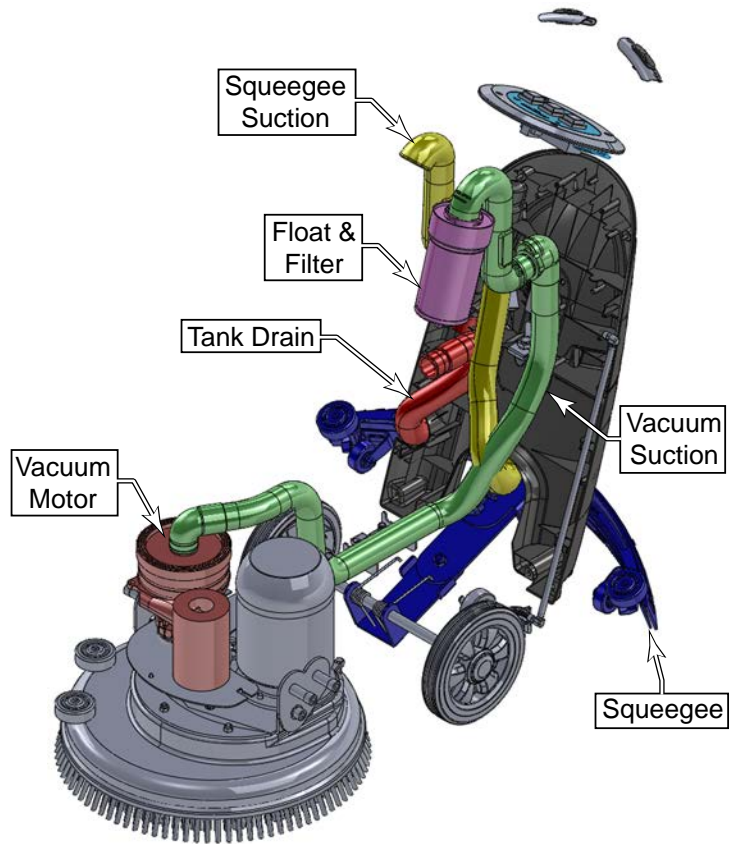

Troubleshooting

The following sections present some common troubleshooting scenarios based on symptom.



Warning! *Risk of electrical shock. Some of the procedures below require examining parts of the machine while electrical power is present. Use care when examining or troubleshooting the machine when power is present. Always disconnect power from the machine before and after these examinations are performed.*

Vacuum Motor (17E)

The vacuum motor circuit gets its power from the main power switch, which then passes through a 5-amp circuit breaker before reaching the motor. The vacuum motor has brushes, which may also be a cause of motor failure.

- Check the vacuum 5-amp circuit breaker for trip by pressing in on the button.
- Remove the control panel and check for line voltage across both pair of terminals on the vacuum switch when the switch is in the on-position. If not, replace the switch.
- Inspect the motor brushes and replace if necessary. (See [Vacuum Motor Brushes](#) described on page 39.)

Vacuum Motor (20B)

The vacuum motor circuit gets its positive-power from the control board, and negative-power direct from the battery disconnect. Failure of the vacuum motor can generally be isolated to 1 of 3 areas: motor brushes, control board failure, or switch failure. The brushes may be the most likely cause, but it is easiest to eliminate other causes before disassembling the machine.

1. Verify that the vacuum switch is functioning by performing the procedure [Power, Vacuum, Solution, and Brush Switches](#) described on page 25.
2. Check the voltage from the control board when the vacuum should normally be running. The voltage between the “Vac Motor” terminal and “GND” terminal should be 24 volts. If 24 volts is not present, replace the control board.
3. Remove the vacuum motor from the machine (a prerequisite to replacing the motor brushes), and check the voltage at the motor. If 24 volts is present, then replace the brushes as described on [page 39](#).

Weak Suction

The most common cause for weak suction is a vacuum leak, but it may also be caused by a blockage.

- A blockage can be identified as the cause if the vacuum pressure feels weak when air is flowing, but feels strong when completely blocked (high static pressure). If a blockage is suspected:
 - Inspect and clean the float/filter canister in the recovery tank.
 - Inspect the suction lines for obstruction.
- A vacuum leak can be identified as the cause if the vacuum pressure is low when blocked or unblocked. If a vacuum leak is suspected:
 - Make sure the recovery tank cover is properly closed and seated.
 - Make sure the recovery tank cover gasket is not damaged or torn.
 - Make sure the recovery tank drain hose is not open.
 - Inspect the squeegee suction hose for tears or holes.
 - Inspect the squeegee blades for tears, and proper trim adjustment ([page 58](#)).
 - Inspect the vacuum suction hose between the vacuum motor and recovery tank.

Removal and Installation

Vacuum Motor

The vacuum motor is located above the scrub deck. The inlet to the vacuum motor comes from the recovery tank via a flexible hose. The exhaust from the motor passes through a sound attenuator and out of the machine above the scrub deck.

1. Make sure the solution and recovery tanks are empty. Excess weight in the tanks can throw off the balance of the machine when the weight of the scrub deck is removed from the machine.
2. Remove the [Scrub Deck](#) described on page 46.
 - When disconnecting the motor connector (F) and solution solenoid connectors (G) in the procedure, also disconnect the vacuum motor connector (H).
3. Prop the machine up so it does not tilt forward while working under the recovery tank.

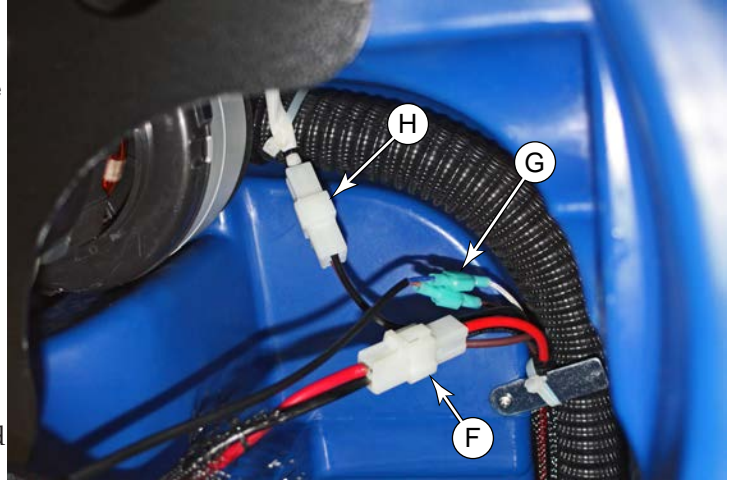

4. Remove the forward-most mounting screw (B) from the vacuum plate (A).
5. Loosen, but do not remove, the two rearward mounting screws (C) from the vacuum plate (A). (The screws may be removed, but reinstallation is easier when the screws remain in position.)
6. Slide the vacuum plate out from the mounting screw slots, and support the motor as you remove the plate.

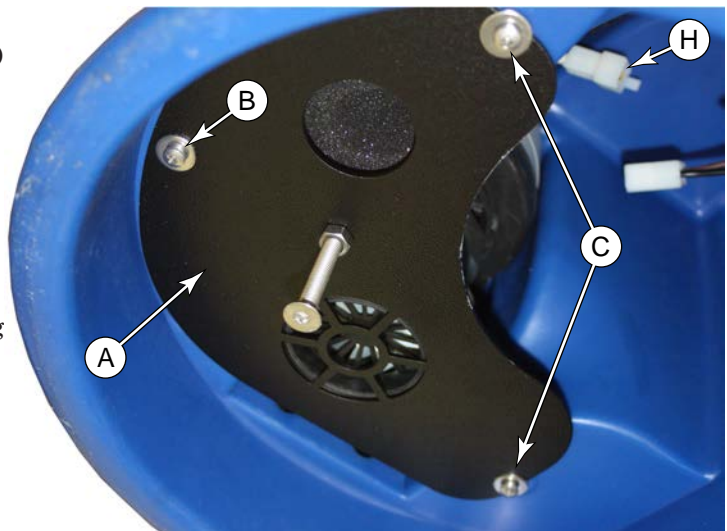

7. Carefully cut the wire tie (**E**) that holds the motor connector (**H**) to the vacuum hose.
8. Loosen the hose clamp (**D**) and remove the motor from the vacuum hose.

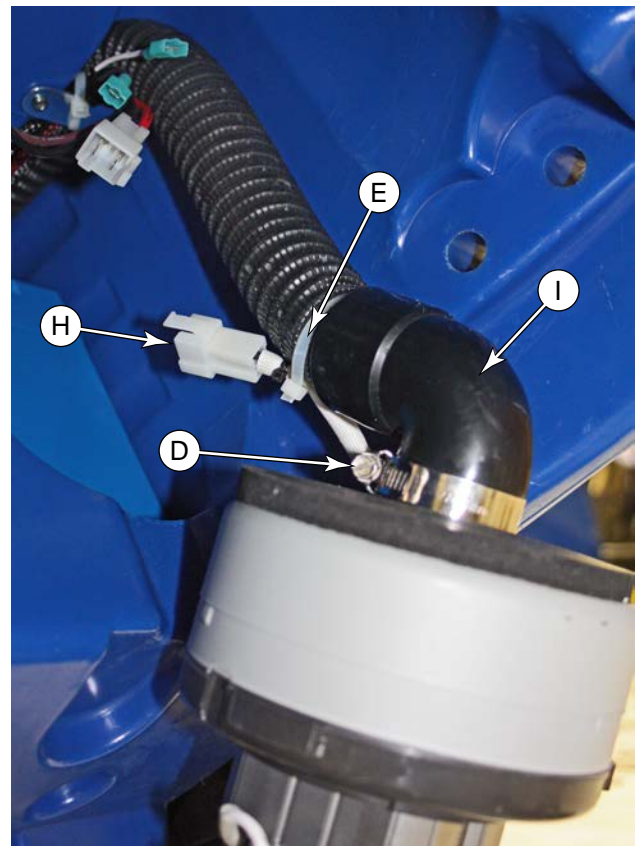

Replacement Notes

- The rotational position of the vacuum hose elbow (**I**) determines the rotational position of the blower's exhaust (**J**), which must line up with the hole in the vacuum plate. To set this position, leave the hose clamp (**D**) slightly loose, put the motor in position and rotate the motor as needed. Then lower the motor to tighten the hose clamp.
- The vacuum motor is supported by the lower gasket (**K**) against the vacuum plate. You may find it helpful to temporarily hold the gasket to the motor with a piece of tape while positioning the vacuum plate. Remove the tape after the plate is installed.
- Reinstalling the vacuum plate and motor is easiest if the rearward mounting screws (**C**) are in position but left loose.
- Before installing the forward screw (**A**), make sure the exhaust (**J**) and motor gasket (**K**) are centered in their respective holes.

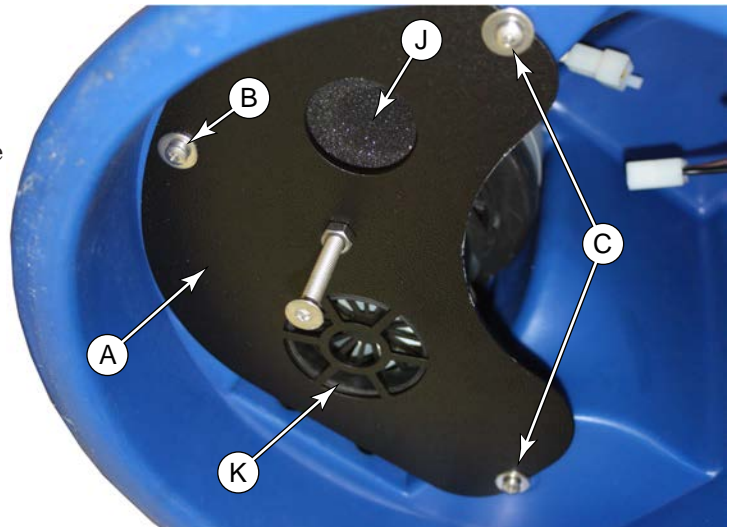

Vacuum Motor Brushes

The vacuum motor brushes are a wear item that should periodically be inspected and replaced.

1. Make sure the solution and recovery tanks are empty. Excess weight in the tanks can throw off the balance of the machine when the weight of the scrub deck is removed from the machine.
2. Remove the [Scrub Deck](#) described on page 46.
3. Remove the [Vacuum Motor](#) described on page 37.
4. Remove the two screws **(B)** that secure the brush cover **(A)**, and remove the cover.
5. Remove the two screws **(C)** that secure the brush holder **(D)** to the motor.

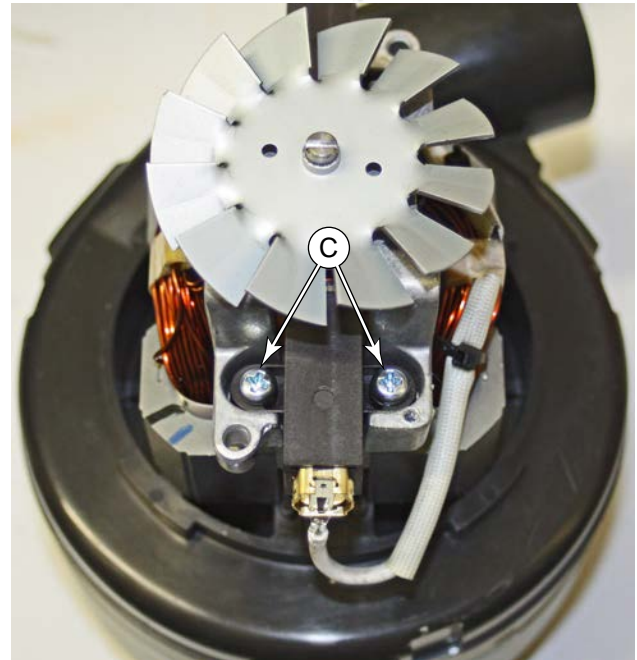
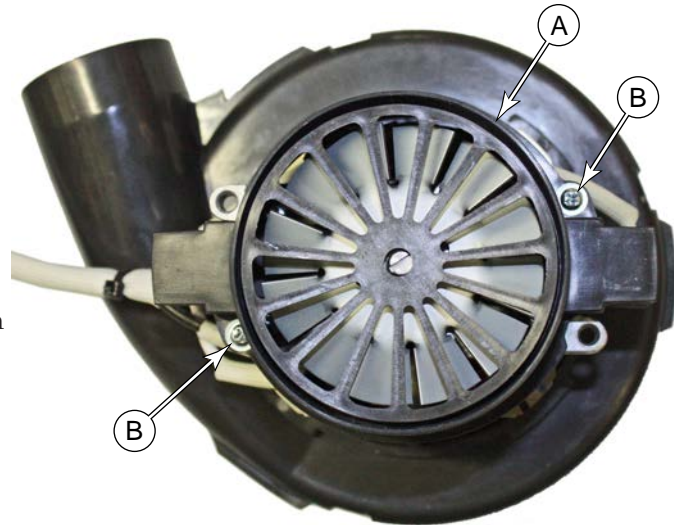

6. Tilt the brush holder **(D)** out of its pocket, and slide it away from the motor.
7. Examine the commutator bars **(E)**. If any are damaged or missing, replace the motor.

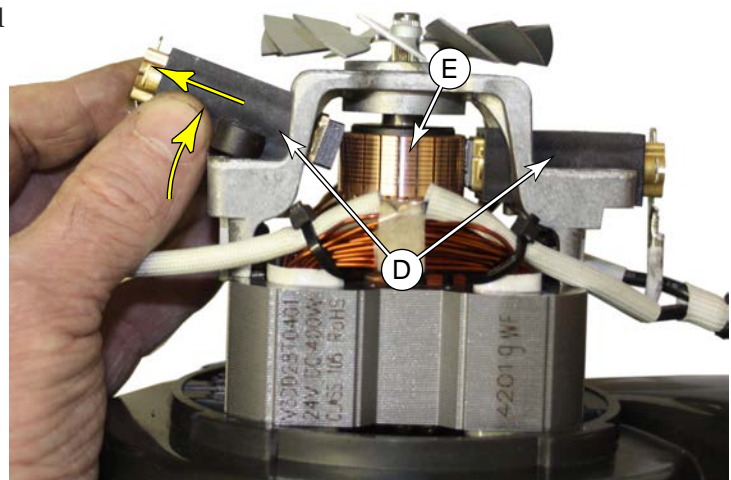

8. Press in on the retaining tab (G) and slide the brush wire (F) out of the brush holder.
9. Slide the brush (H) out the rear of the brush holder (D).
10. Slide the new brush into the brush holder.

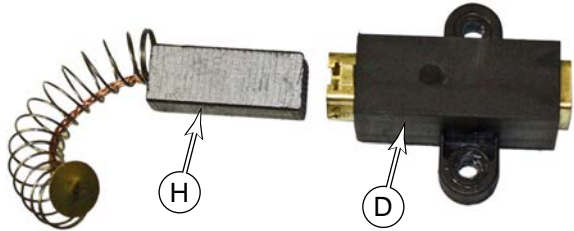

11. With the brush and its spring contact plate fully inserted into the brush holder, replace the brush wire (F) into the brush holder. The brush wire also serves to retain the brush, so it needs to be installed before the brush holder is replaced in the motor.

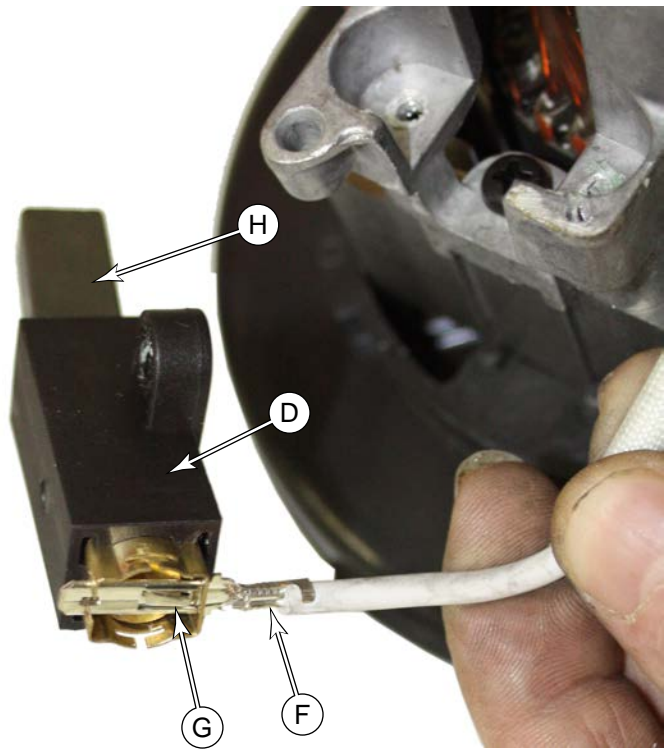

12. Align the tip of the carbon brush (H) against the commutator (E).
13. Slide the brush holder inward, compressing the spring.
14. Lower the brush holder into the pocket in the motor housing.
15. Reinstall the two retaining screws (C).
16. Repeat the process for the second brush.
17. Before replacing the brush cover, examine the cooling fan impeller for damaged or bent blades.
18. Replace the brush cover (A).

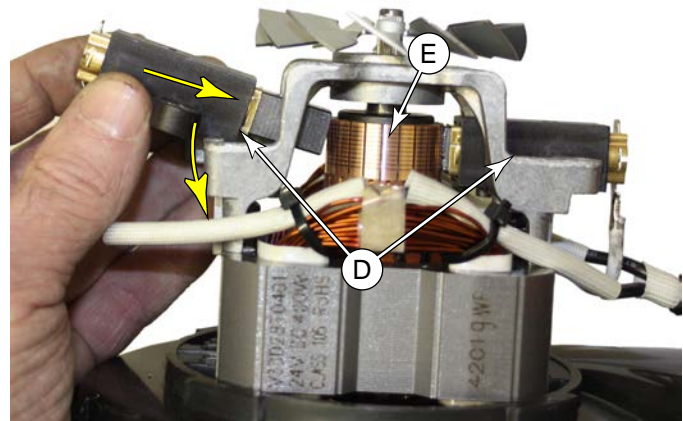

19. Reinstall the vacuum motor in the machine as described on [page 38](#).

Scrub System

Functional Description

The scrub system consists of scrub brush or pad, which is powered by a drive belt from the brush motor. The drive belt and pulleys results in nearly a 10-to-1 speed reduction of the brush. This significant speed reductions results in a proportional increase in torque.

The scrub deck floats on a pair of pivot brackets. This allows the scrub brush/pad to rest flat on a floor as the machine moves. The left of these pivot brackets is rigid in height position, but the other floats vertically. This applies a slightly greater force on the left side of the scrub pad, which in turn assists in propelling the machine forward.

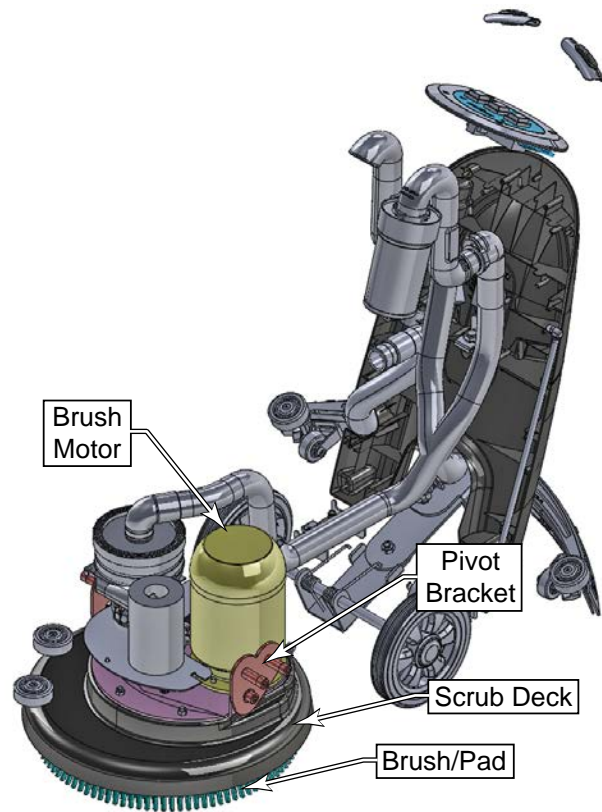

Troubleshooting

Brush Motor (17E)

Caution! *If the brush motor does not reach normal operating speed within a few seconds of receiving power, immediately disconnect power to prevent further damage to the motor. Prolonged high-amperage current through the windings can permanently damage the motor.*

The brush motor is a capacitor-start/capacitor-run induction motor. The two primary failure-modes of this type of motor are when it's not receiving any power, or when the start circuit is not functioning properly. During normal operation, you should hear 2 clicks as the motor starts and stops. The first click is the scrub relay providing power to the motor, and the second click is the start relay disconnecting the start capacitor. This is reversed when the motor shuts down. If the second click isn't heard, it means the start circuit isn't functioning.

No Power

- If neither the solution solenoid nor brush motor are functioning, proceed to the [Scrub System \(17E\) described on page 44](#).
- If the solution solenoid is functioning, then the 24-volt power supply and scrub control relay coil can be eliminated as the cause. However, a failed contact or loose wire could still be the cause.
 - The scrub control relay has 3-pair of contacts, but only 2-pair are being used. To verify that the brush motor contacts have not failed, move the wires for the brush motor to the unused contact pair. This pair can be easily identified, because one of them will connect to the adjacent brush motor starter.
- If the brush motor functions after relocating the wires to the unused contacts, then the relay should be replaced. The relay has severe internal damage and should not be used.

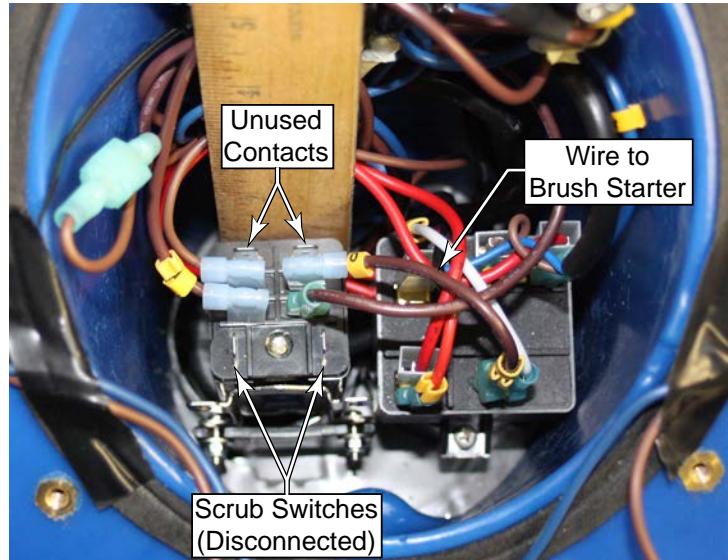

Low Speed, Lack of Power, or Overheating

These symptoms and conditions are related to a failed start circuit. If not diagnosed quickly, many of these conditions can cause permanent damage to the motor. While making observations, it is important to not run the motor for more than a second or two, and to allow the motor windings to cool down between observations.



Caution! *The motor start and run capacitors can hold a significant electrical charge long after power has been disconnected. Take care when handling any wires leading to the capacitors.*

- If the brush motor comes up to speed rapidly, but is very noisy, overheats without load, or trips the circuit breaker, then it is most likely that the start relay is not disconnecting the start capacitor when it should. Replace the start relay.
 - This condition can rapidly damage the motor. Do not permit the machine to operate in this condition.
 - The motor will sound very loud and unbalanced (not smooth).
- If the brush motor turns slowly, hums without turning, or is very slow to reach operating speed without load, then the most likely cause is a failed start capacitor. Replace the start capacitor (see [page 19](#))
 - This condition can rapidly damage the motor. Do not permit the machine to operate in this condition.
 - This is the most common failure mode of a capacitor-start motor.
- If the brush motor gets up to speed reasonably fast but lacks power or bogs down easily, it is likely that the run capacitor has failed.

Start Relay Troubleshooting Voltage Readings

Most brush motor troubleshooting can be completed by simple observations. The table below provides further information if confirmation is required, or to isolate the cause of similar symptoms. As with other troubleshooting observations, these measurements should be performed for no more than a couple seconds at a time, and time should be given to allow the motor windings to cool between measurements.



Warning! Risk of electrocution. These measurements require measurement of voltages with the system powered and active. Unplug the machine while setting up the test probes, and stay clear of the probes and system wiring when the machine is powered.

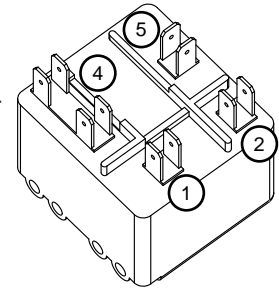

V_o = Voltage Off, V_s = Voltage Startup, V_R = Voltage Running

| Normal Operation | | | | | |
|------------------|-------|-------|-------|-------|---|
| Terminals | V_o | V_s | V_R | Scope | Comment |
| 2-4 | 1.0 | ↑ | 239 | | |
| 2-5 | 0 | ↑ | 203 | | |
| 2-1 | 0 | 0 | 239 | | Shorted, then Jumps after relay opens |
| 1-4 | 0 | 69 | 0 | | Building start capacitor voltage, then disconnected |
| 1-5 | 0.7 | 15 | 1.3 | | Building start capacitor voltage, then disconnected |
| 4-5 | 0 | 120 | 120 | | Normal line voltage |

| Failed Start Capacitor (Never Reaches Run Speed, Relay Never Opens) | | | | | |
|---|-------|-------|-------|-------|---|
| Terminals | V_o | V_s | V_R | Scope | Comment |
| 2-4 | 0 | 105 | --- | | |
| 2-5 | 0 | 21 | --- | | |
| 2-1 | 0 | 0 | --- | | Shorted by relay contacts, relay never opens |
| 1-4 | 0 | 105 | --- | | Same as 2-4 |
| 1-5 | 0 | 21 | --- | | Same as 2-5 |
| 4-5 | 0 | 95 | --- | | Voltage drop in power cord due to high amperage |

| Failed Run Capacitor (Relay Opens Normal) | | | | | |
|---|-------|-------|-------|-------|---------------------------------------|
| Terminals | V_o | V_s | V_R | Scope | Comment |
| 2-4 | 0 | ↑ | 191 | | Slight stutter as relay opens |
| 2-5 | 0 | ↑ | 140 | | Slight stutter as relay opens |
| 2-1 | 0 | → | 191 | | Shorted, then Jumps after relay opens |
| 1-4 | 0 | 120 | 0 | | Same as 2-4 until relay opens |
| 1-5 | 0 | ↑ | 120 | | |
| 4-5 | 0 | 120 | 120 | | Same as normal operation |

| Failed Start Relay (Start Circuit Never Disengages) | | | | | |
|---|-------|-------|-------|-------|--|
| Terminals | V_o | V_s | V_R | Scope | Comment |
| 2-4 | 0 | ↑ | 170 | | The motor starts normally, but then enters an over-powered condition when the starter doesn't disengage. |
| 2-5 | 0 | ↑ | 220 | | |

Scrub System (17E)

The scrub system combines the functions of the solution solenoid and the brush motor for the purpose of limiting the solution flow only when the brush motor is active. The scrub control relay allows simultaneous, yet isolated, control of both the low-power solution circuit and the high-power brush motor circuit. The relay uses a low-voltage coil (24VDC) so that high-voltage power is not required in the operator's handle for the brush switches.

The failure modes of the scrub system include loss of the 24VDC power supply, failure of the scrub control relay, and to a lesser degree, failure of both brush switches in the handle. The reason why the switches are less likely to be the cause of the failure is because both independent switches would have to fail simultaneously.

- Because the solution solenoid and brush motor are otherwise isolated, if both are non-functional, the likely cause is that the scrub relay has not engaged.
- If 24 volts is present at the scrub relay coil when the brush switch(es) are closed, then the relay is the cause.
- Verify that the 24-VDC power supply is receiving 120-volt power.
- Verify that the output of the power supply is 24 volts when receiving 120-volt supply.

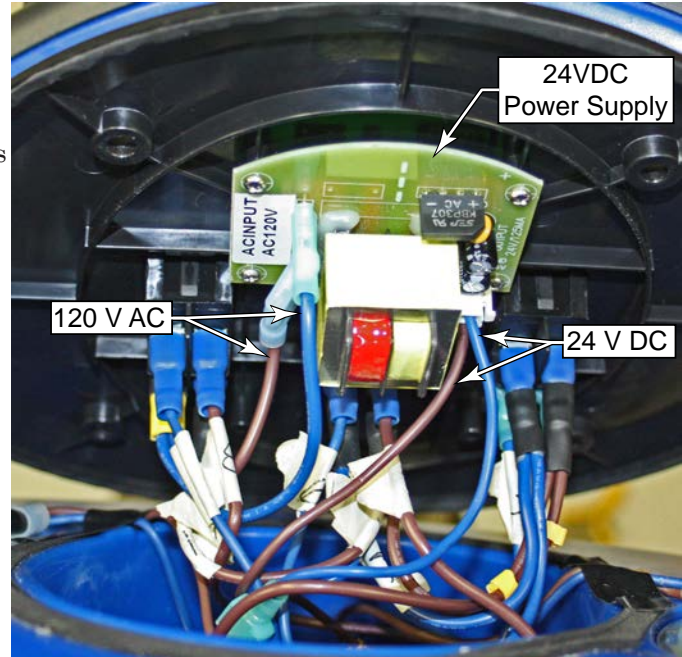

Brush Motor (20B)

The brush motor is a DC-powered, internally commutated (carbon brush) motor. The motor receives positive battery power through its own dedicated 30-amp circuit breaker. Negative battery power comes from the brush relay located adjacent to the control board. The brush relay coil receives both positive and negative power directly from the control board. Failure of the brush motor can generally be isolated to the 30-amp circuit breaker, the brush relay, the motor's carbon brushes, the control board, or the brush switches in the machine handle.

If the brush motor is non-functional, make the following inspections and observations. The sequence of the following examinations is based on ease of access, and not necessarily by likelihood to occur.

1. Check the function of the brush circuit breaker.
2. Hold both brush switches closed. If the brush motor works with one switch but not the other, then the switch or the wires at the switch are the cause.
3. Verify the function of the switches by performing the procedure [Power, Vacuum, Solution, and Brush Switches](#) described on page 25.
4. Turn the solution switch on and hold both brush switches.
 - If solution does not flow, then the most likely cause is the control board itself, or the brush switch connection at the control board. If 24 volts is present between C- and GND on the control board, then the control board has failed.
 - If solution does flow, the control board is not likely the cause, but one more check (brush relay coil voltage) is required to eliminate the control board as the cause.
5. Check the voltage across the brush motor relay coil.
 - If 24 volts is not present (and the above examination was complete), then the control board is faulty and must be replaced.
 - If 24 volts is present, then the function of the relay will be identified or eliminated in the next step below.
6. Check the voltage between battery positive and the output lug of the brush relay that leads to the brush motor.
 - If 24 volts is not present but the coil had 24 volts in the previous step, then the relay has failed and must be replaced.

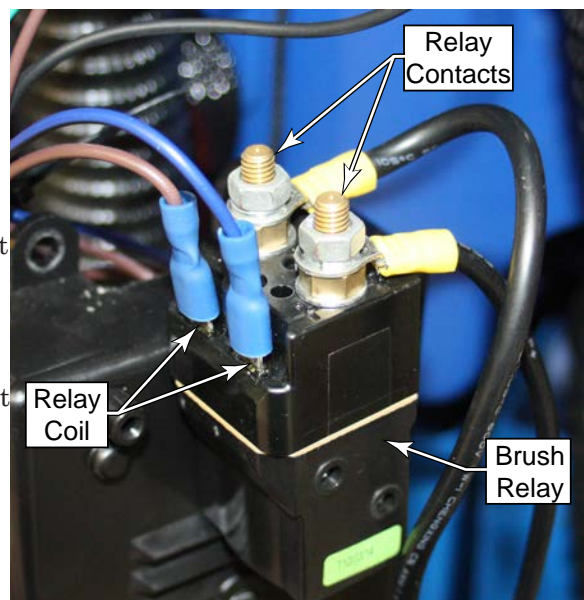

Removal and Installation

Scrub Deck

Removing the scrub deck is a prerequisite procedure for many other procedures that require access to the components on or above the scrub deck. Among other items, this provides access to the brush motor, solution solenoid, and vacuum motor.

1. Make sure the solution and recovery tanks are empty. Excess weight in the tanks can throw off the balance of the machine when the weight of the scrub deck is removed from the machine.
2. Remove the squeegee to permit the machine to tilt back farther without obstruction.
3. Remove the brush or pad holder from the machine, and rest the scrub deck on the floor as shown.
4. Using a 10mm hex key, remove the 4 socket head cap screws (A) and spacer sleeves (B) that secure the scrub deck (C) to the machine.
5. Slowly tilt the machine back until it is stable and resting on the rear idler wheel. The scrub deck (C) should remain on the floor.

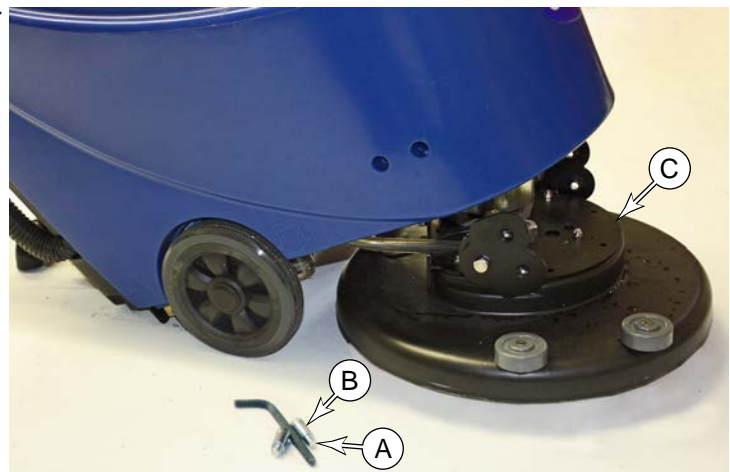
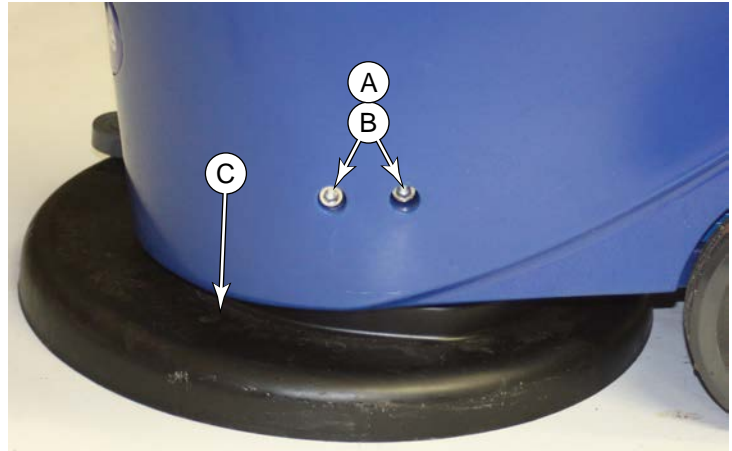

6. Disconnect the solution hose (D) from the solution filter (E).
7. Move the scrub deck forward, but not so far that you pull on the wires.

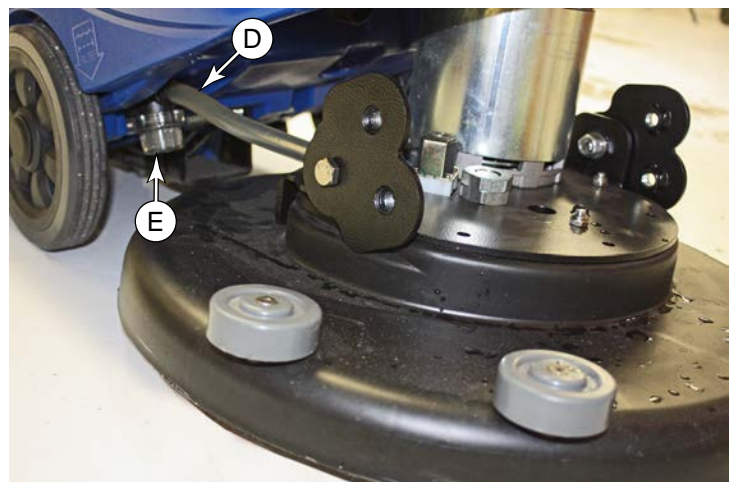

- Disconnect the motor connector (F) and solution solenoid connectors (G). It is not necessary to disconnect the vacuum motor connector (H), unless you need to service the vacuum motor.

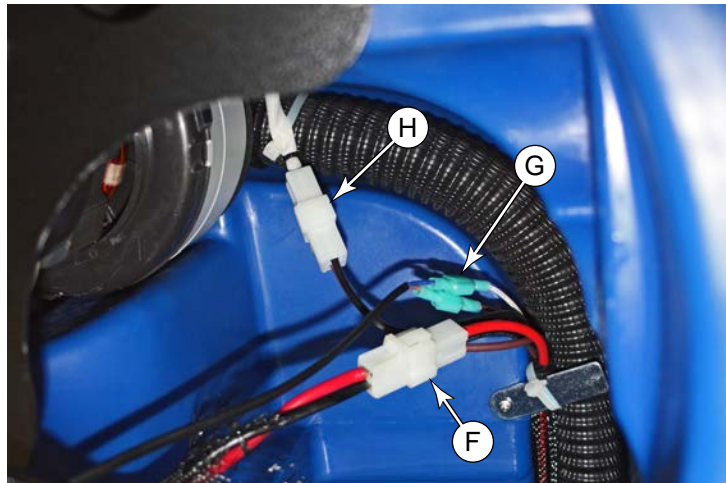

Replacement Notes

The replacement procedure is the reverse of the disassembly. When installed in the machine, the scrub deck floats on two pivot brackets to conform to the slope of the floor. The left bracket rotates about its bolt. The right bracket both rotates and slides vertically. If you have difficulty holding these brackets in the vertical position while lowering the machine, use the following tips to help align them during reassembly.

- Move the scrub deck into position below the machine. Verify the position by temporarily lowering the machine to ensure it clears the top of the brush motor. Raise the machine back up.
- Route a piece of string or light rope (L) through one of the mounting holes in the machine body (K).
- Route the string through the corresponding hole (J) in the pivot bracket (I). Note that the string is routed from outside to inside through the bracket.
- Repeat the same for the second pivot bracket.
- While lowering the machine body down over the scrub deck, pull the string tight to keep both pivot brackets vertical.
- Loosely install the first screws and sleeves (left & right), but do not fully tighten them yet.
 - Because the right-hand bracket slides vertically, you may need to push up slightly from the bottom to align the hole.
- Remove the string and install the remaining two screws and sleeves.
- After all 4 screws are loosely installed, tighten them all down.

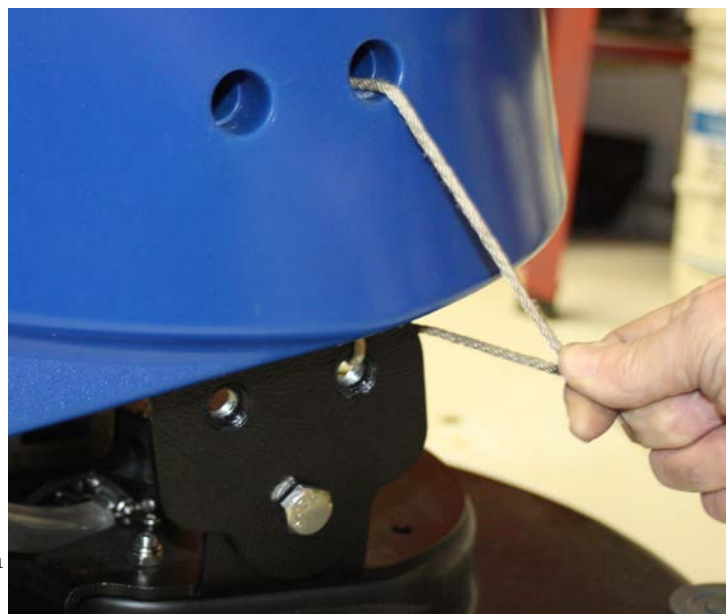
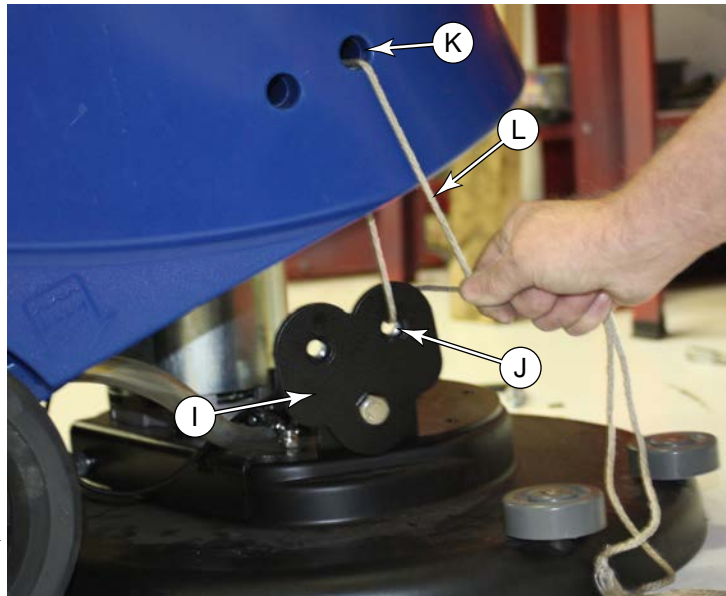

Brush Drive Belt

The brush drive belt should be periodically inspected and replaced. The drive belt is ribbed for better engagement with the motor shaft. Belt tension is controlled by a spring loaded idler pulley.

1. Although not required, it is much easier to perform this procedure with the scrub deck removed from the machine. Remove the scrub deck as described on [page 46](#).
2. Using a 19mm wrench, loosen the belt tension jam nut (A).
3. Using a 12mm open-end wrench, fully loosen (but do not remove) the belt tension screw (B).

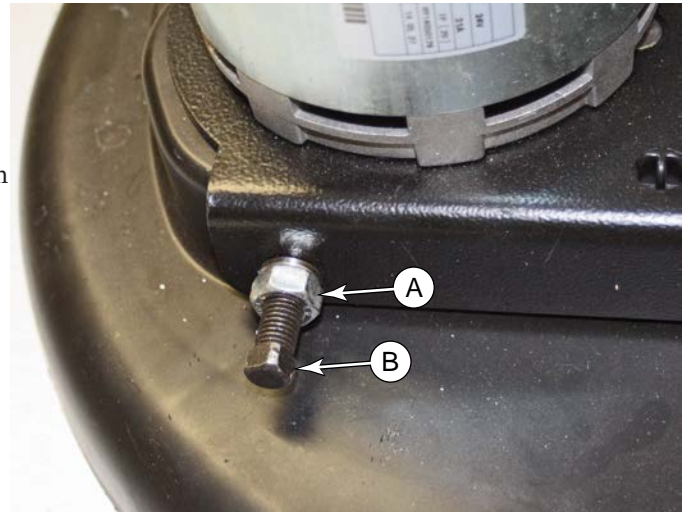

4. Starting at the pad hub (C), lift the drive belt (F) off the pulleys (C&E) and off the motor shaft (D).

Replacement

1. Before replacing the belt, inspect the idler and brush hub bearings. The pulleys should turn smooth and easily, but not so easy that they freewheel-spin. Replace if necessary.
2. Wrap the ribbed side of the belt around the motor shaft. Make sure the ribs are aligned and the top rib on the drive belt is in the top groove on the motor shaft.
3. Wrap the smooth side of the drive belt around the idler pulley (E).
4. Finish wrapping the belt around the brush hub (C).
5. Begin tightening the belt tension screw (B) and make sure the tension spring (G) is correctly in position.
6. Continue tightening the tension screw until reasonable hand pressure against the belt at (H) deflects the belt approximately 1/8" (3mm).
7. While holding the tension screw (A) from turning, tighten the jam nut (B).

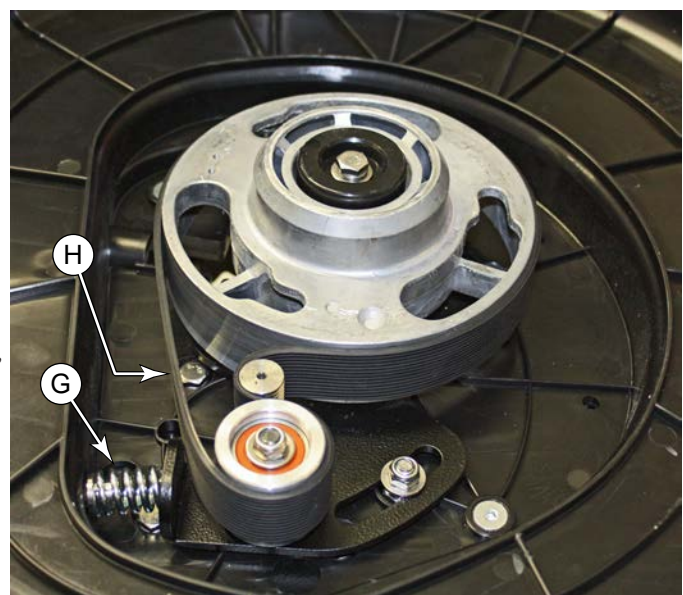
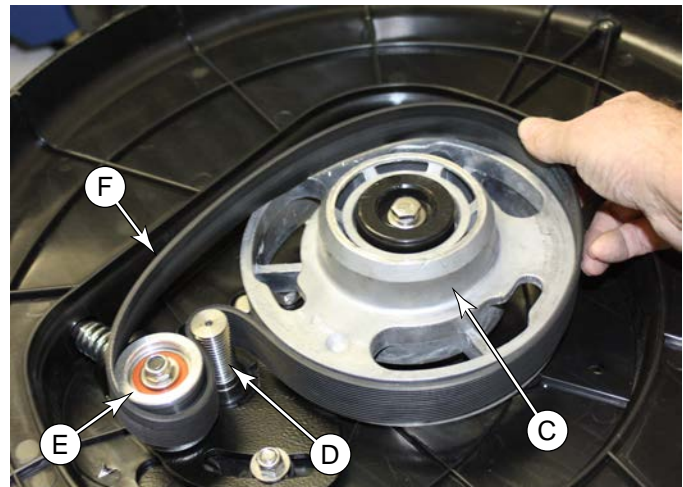

Motor Carbon Brushes (Battery Model)

The motor brushes provide an electrical connection to the spinning rotor. The motor contains 4 brushes. The brushes will wear over time and must be replaced. The copper strips on the rotor that the brushes contact are called the commutator bars, and these are connected to the individual windings on the rotor.

1. Remove the [Scrub Deck](#) described on page 46.

Caution: The position of the end bell (top cap) of the motor is critical to the operation and clearances within the motor. Do not remove the end bell. Do not loosen the screws securing the end bell.

Caution: Take care to not drop any objects into the motor. The motor contains permanent magnets, which may make retrieving metal objects difficult.



2. Remove the two screws (B) that secure the brush shield (A) to the motor, and remove the shield. Take care when loosening the last screw, as the shield is springy and may fling the last screw.

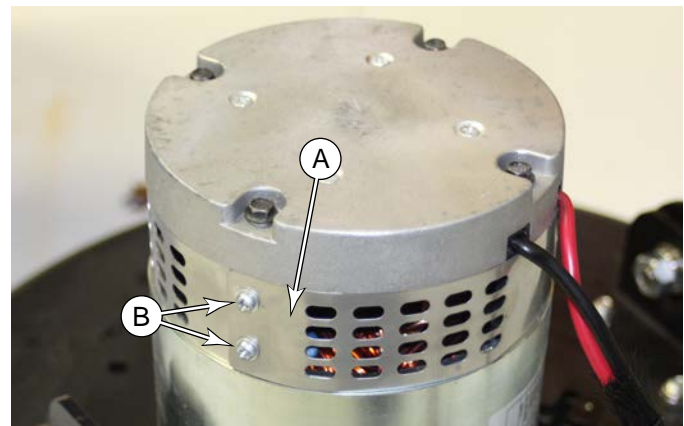

The components of the brush mechanism are shown. There are 4 of these mechanisms spaced around the motor. The coiled spring (D) presses against the top of the carbon brush (C), pressing it against the commutator bars of the rotor. The carbon brush has a flexible, embedded wire that connects to the incoming power connections (E).

3. Remove the terminal nut (E).
 - Take care not to bend the terminal. Hold the terminal from twisting as you loosen the nut.
 - Take care to not drop the nut (or anything else) into the motor.
4. Remove the brush wire from the terminal.

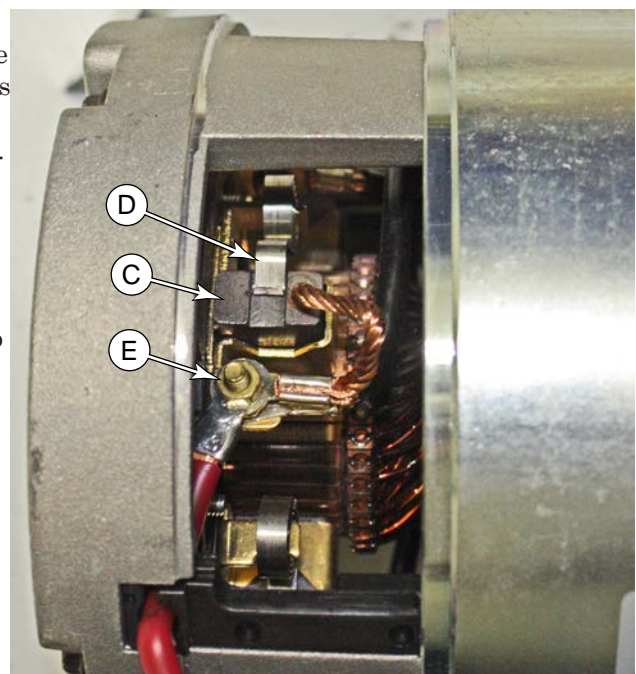

5. Using a small hooked tool, such as a dental tool (**F**), lift the spring (**D**) off the top of the brush. Take care to not release the spring or uncoil it.
6. While holding the spring away from the brush, slide the old brush (**C**) out of the brush holder, and slide in the new brush.
 - Make sure the embedded brush wire (**G**) is facing toward the bottom of the motor (toward the output shaft).
7. Release the spring and make sure it is position in the depression (**H**) in the center of the brush.
8. Connect the wire (**G**) to the terminal (**E**) and tighten the nut. Take care to not bend the terminal.

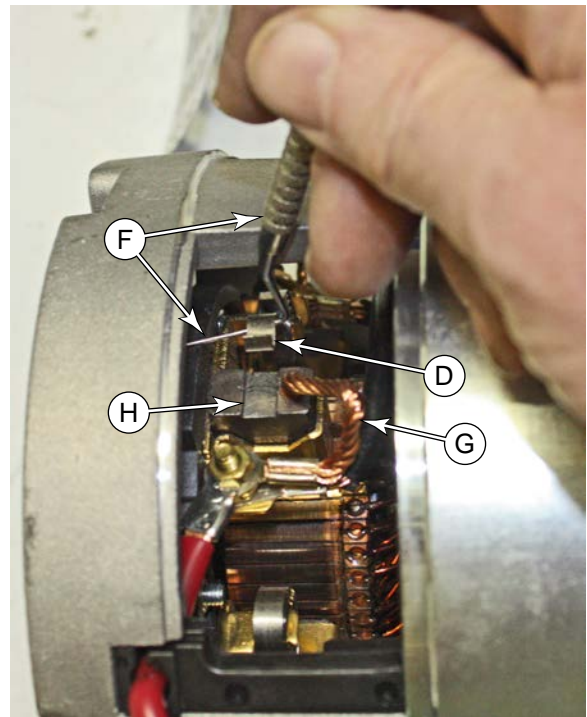
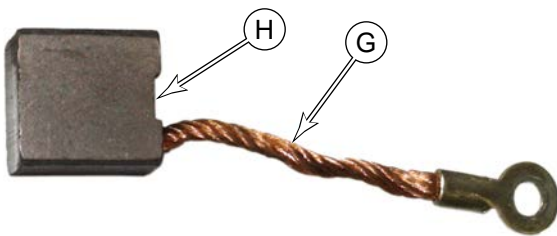

9. Repeat the steps for the other 3 brushes.

Solution System

Functional Description

The solution tank is molded into the main body of the machine, and is located below the recovery tank. It is comprised of the hollow interior of the main body of the machine.

The solution exits the solution tank at the lower-right corner through a flow-control and shutoff valve. The solution then passes through a filter, before reaching the solution solenoid. The solution valve can be adjusted to control the amount of solution flow. The solution solenoid is strictly on/off.

The exit of the solution solenoid is positioned above the scrub brush/pad to put solution into the scrubbing area. The solution solenoid can be active only when the scrub motor is active.

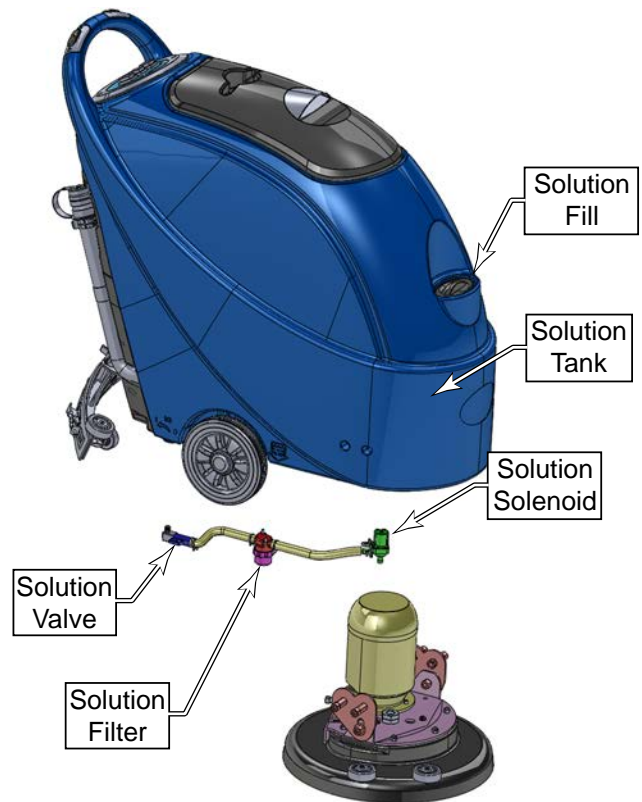

Maintenance and Adjustment

Solution Filter Cleaning

The solution filter prevents large particles from fouling the solution solenoid, and must be cleaned periodically.

1. Turn off the solution valve **(A)** by rotating the handle perpendicular to the flow.
 - Note that there will still be some water in the lines when you remove the filter.

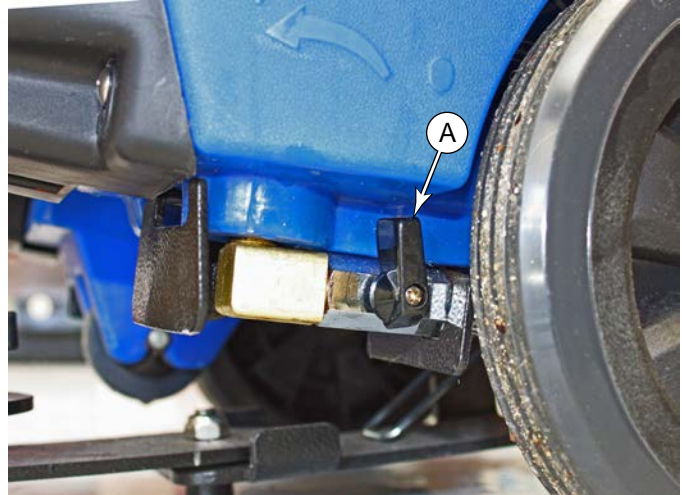

2. Tilt the machine up to access the filter just behind the scrub deck.
3. Unscrew the filter bowl from the filter body.

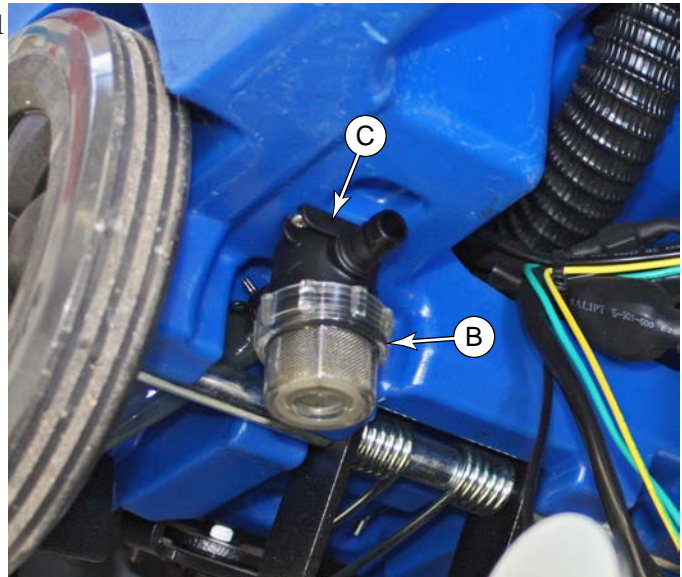

4. Rinse the filter bowl and screen **(D)**. **Do Not** try to remove the screen from the bowl.

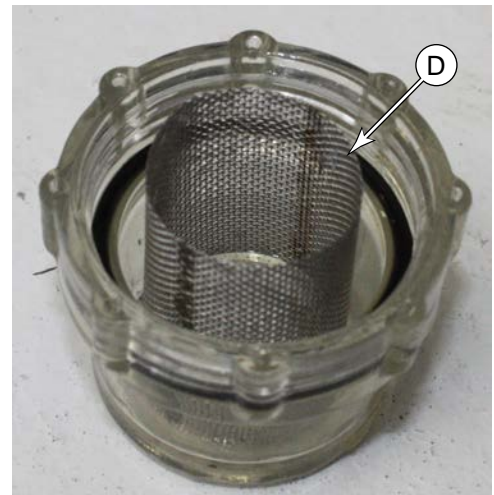

Troubleshooting

The following sections present some common troubleshooting scenarios based on symptom.



Warning! *Risk of electrical shock. Some of the procedures below require examining parts of the machine while electrical power is present. Use care when examining or troubleshooting the machine when power is present. Always disconnect power from the machine before and after these examinations are performed.*

Solution Solenoid (17E)

If neither the solution solenoid nor brush motor are functioning, proceed to the [Scrub System \(17E\)](#) described on page 44.

- If the brush motor is functioning, then the 24-volt power supply, scrub switches, and scrub control relay can be eliminated as the cause.
- Remove the control panel and check for line voltage across both pair of terminals on the solution switch when the switch is in the on-position. If not, replace the switch.
- Check for voltage at the solution solenoid. If line voltage is present, replace the solenoid.

Solution Solenoid (20B)

The solution solenoid will be active only when the brush motor is active. If the brush motor is not functioning, troubleshoot the brush motor first. The solution solenoid receives both positive and negative power directly from the control board. Failure of the solution solenoid can generally be isolated to 1 of 3 areas: the solenoid itself, the control board, or the solution switch.

1. Verify that the solution switch is functioning by performing the procedure [Power, Vacuum, Solution, and Brush Switches](#) described on page 25.
2. Check the voltage from the control board at the wire connectors just below the control board. If 24 volts is not present between the two wires, replace the control board.
3. Lower the brush deck out of the machine (a prerequisite to replacing the solenoid), and check the voltage at the solenoid. If 24 volts is present, then replace the solenoid as described on [page 54](#).

Removal and Installation

Solution Solenoid

The solution solenoid is located on the scrub deck. The inlet to the solution solenoid comes from the solution filter, and the outlet points downward into the center of the scrub brush.

1. Make sure the solution and recovery tanks are empty. Excess weight in the tanks can throw off the balance of the machine when the weight of the scrub deck is removed from the machine.
2. The scrub deck needs to be lowered from the machine, but it doesn't need to be completely removed. Remove (or partially remove) the [Scrub Deck](#) described on page 46.
 - When disconnecting the solution solenoid connectors (**G**) in the procedure, it is not necessary to disconnect the brush motor connector (**F**) unless you wish to completely remove the scrub deck.
3. Prop the machine up so it does not tilt forward while working under the recovery tank.
4. Remove the two mounting screws (**C**) that secure the mounting bracket (**B**) to the scrub deck, and remove the solution solenoid assembly (**A**).
5. Remove the two mounting screws (**D**) and transfer the mounting bracket (**B**) from the old solenoid to the new solenoid.
6. Loosen the hose clamp (**E**) and transfer the solution hose from the old solenoid to the new solenoid.

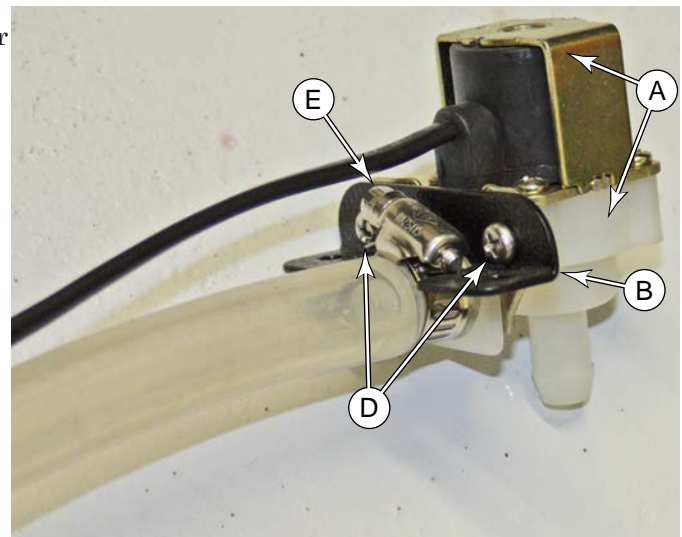
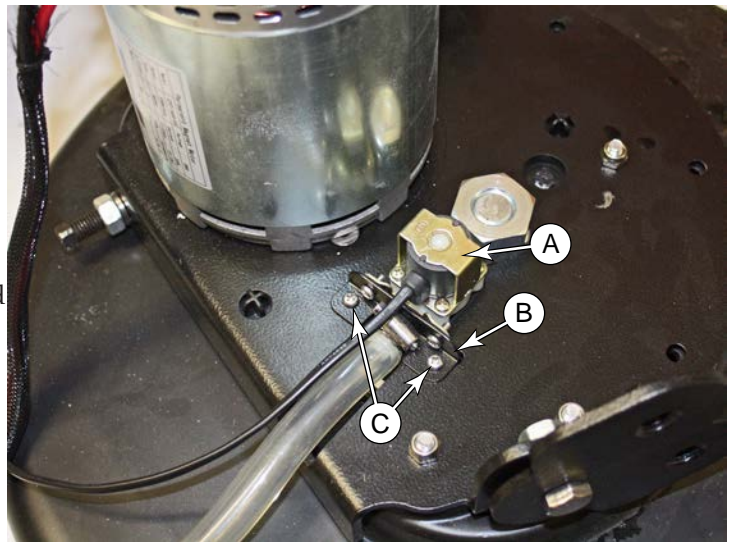
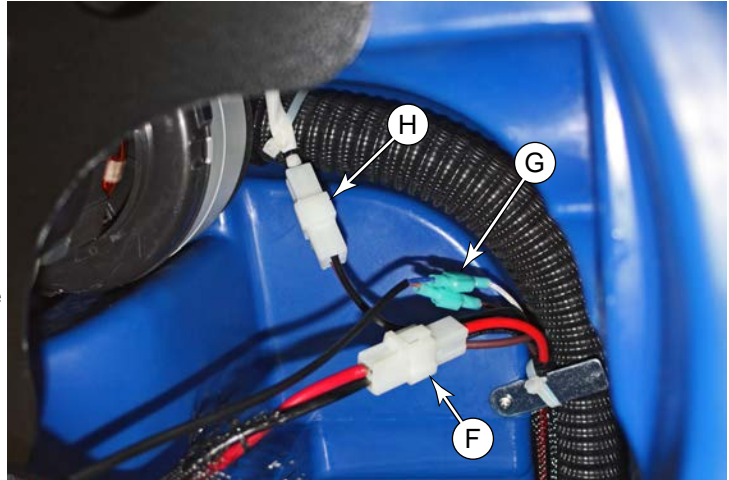

Squeegee System

Functional Description

The squeegee suction hose draws air/water from the squeegee assembly. The squeegee consists of two squeegee blades: a forward, notched blade, and a rear scraping blade. The notched blade permits water to pass into the space between the two blades, where it is drawn into the suction hose.

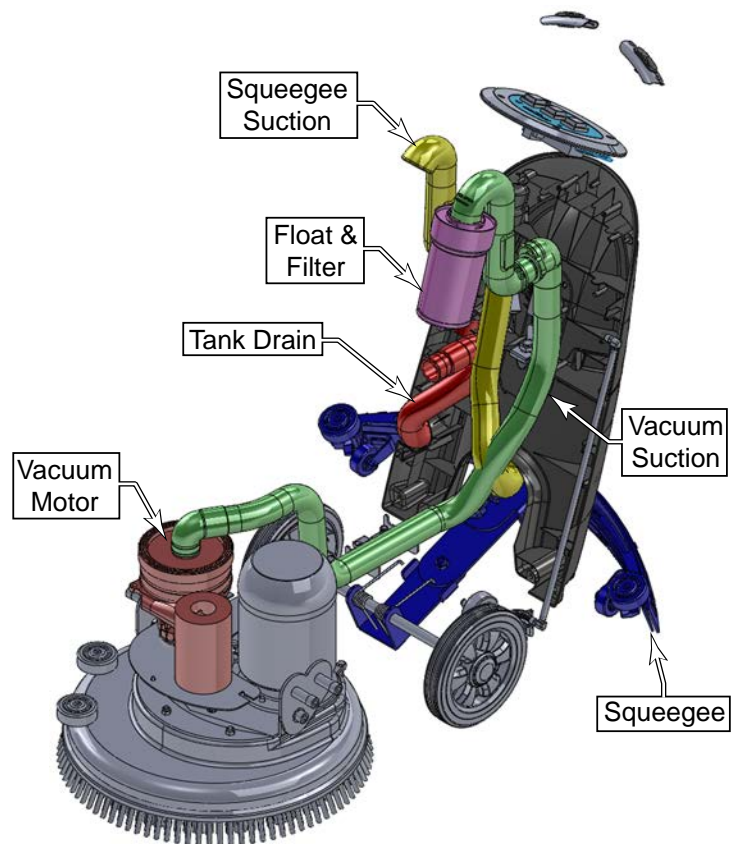

Troubleshooting

Floor Streaks

Generally, floor streaks are caused by a problem with the squeegee. However, they can also be caused by weak suction (see [Weak Suction](#) described on page 36).

- During normal operation, debris can get trapped under the squeegee blades. Periodically raise the squeegee blade to clear debris.
- Clean and inspect the squeegee blades.
- If the streaks consistently appear at the center or outside edges of the squeegee, check the [Squeegee Trim Adjustment](#) described on page 58.
- If streaks are consistently occurring at specific locations on the squeegee blade, check to make sure the blade is flat and without waves (**N**).
- If the waves (**N**) keep reappearing after being corrected, it is an indication that the retaining strap (**I**) is not tightened enough to hold the squeegee blade from slipping.

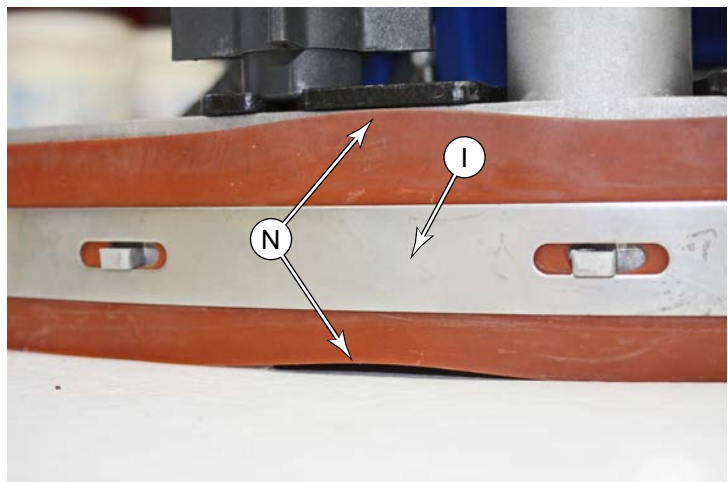

Maintenance and Adjustment

Squeegee Blade Changing

The two squeegee blades periodically need to be changed as they wear. The blades may be flipped or reversed to a fresh edge up to 3 times before replacement is required. During replacement, it is important for the blades to be installed flat without waves, and then also adjusted to rest flat against the floor.

1. Remove the squeegee suction hose (C) from the squeegee assembly (A).
2. Loosen the two thumbscrews (B) and slide the squeegee assembly out of the mounting slots, and remove the squeegee.

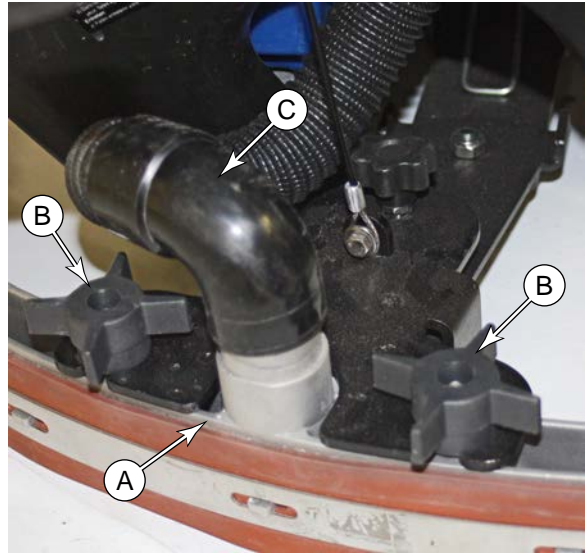

3. Pull out on the latch (D) to release the tension on the retaining strap.
4. Free the retaining hook (E) from the edge of the squeegee frame, and out through the hole in the squeegee blade (F).
5. Do the same for the retaining hook on the other end of the blade.
6. Remove the retaining strap and squeegee blade from the squeegee frame.
 - The squeegee can be rotated and/or flipped 3 times to expose a new edge (4 edges total) to the lower front. If all 4 edges are worn, replace the squeegee blade with a new one.

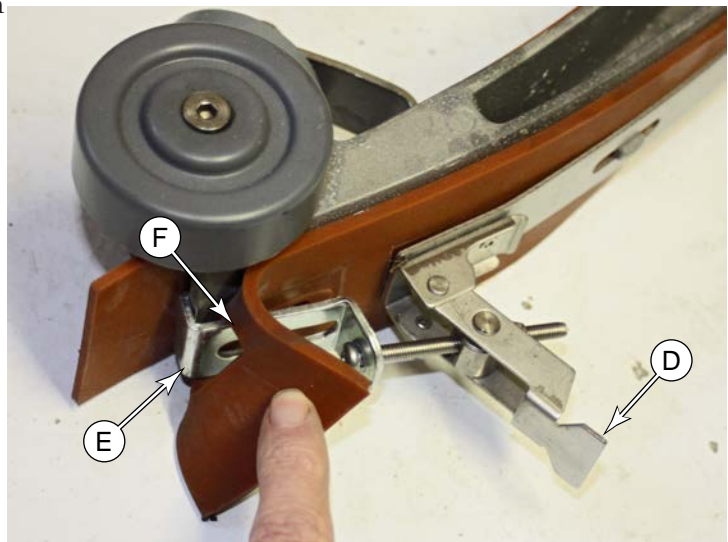

7. To replace the blade, it may be easier to stand the squeegee frame upright.
8. Lay the squeegee blade (G) over the frame (H), and make sure the tabs and slots (J) are aligned.
9. Replace the strap (I) and make sure the hooks (E) pass through the holes in the blade and around the edge of the frame.
10. Before tightening the latch, make sure the blade is straight without waves.

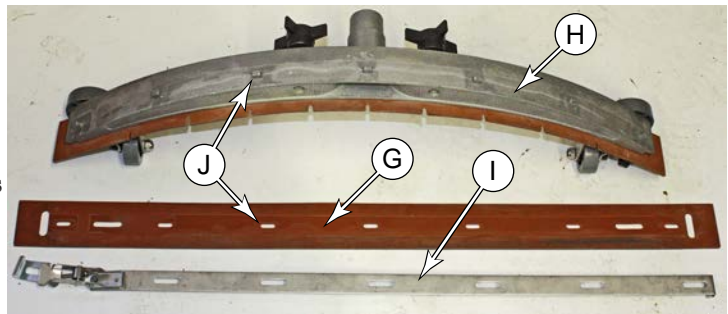

11. Loosen both clamping thumbscrews (**K**) on the rear strap (**L**), and remove the strap from the frame.

12. Remove the rear squeegee blade.

- The squeegee can be rotated and/or flipped 3 times to expose a new edge (4 edges total) to the lower front. If all 4 edges are worn, replace the squeegee blade with a new one.

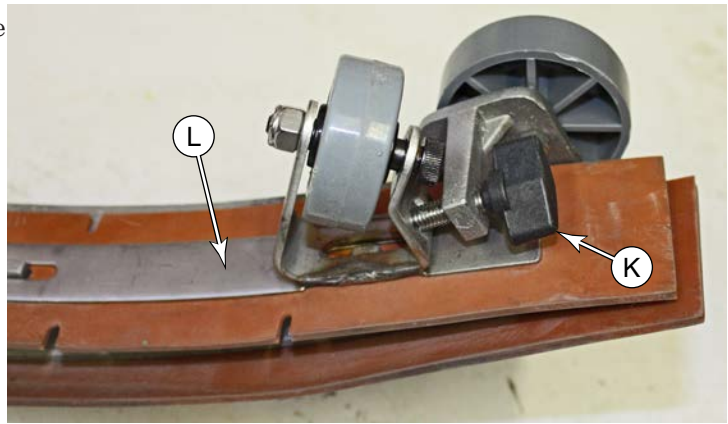

13. To replace the blade, it may be easier to stand the squeegee frame upright.

14. Lay the squeegee blade (**M**) over the frame (**H**), and make sure the tabs and slots (**J**) are aligned.

15. Replace the strap (**L**) and retighten both clamping thumbscrews equally until the strap is tight against the frame.

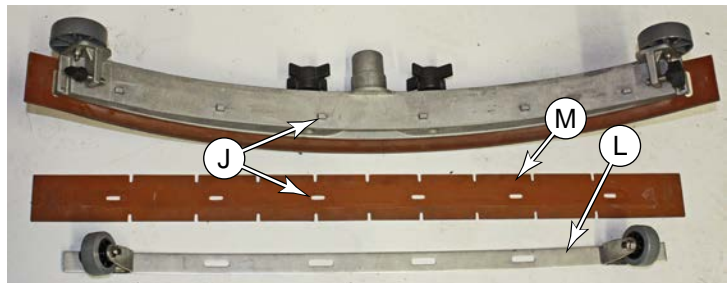

16. Rest the squeegee assembly flat on the floor and examine the edge of each blade (front/rear) to make sure it is flat without any waves (**N**).

- Make this examination with the squeegee assembly still removed from the machine. There should be no unnecessary downward force on the squeegee blades.
- If there are waves, loosen the strap and straighten the blade.

17. Examine both front and rear squeegee blades to make sure they are the same height, and that both blades rest flat on the floor when the squeegee frame is sitting level.

- Because the squeegee is curved, it is important that the blades be level with the frame, and then the frame will be adjusted level to the floor in the next procedure.

18. Reinstall the squeegee assembly to the machine.

19. Perform the [Squeegee Trim Adjustment](#) described on page 58

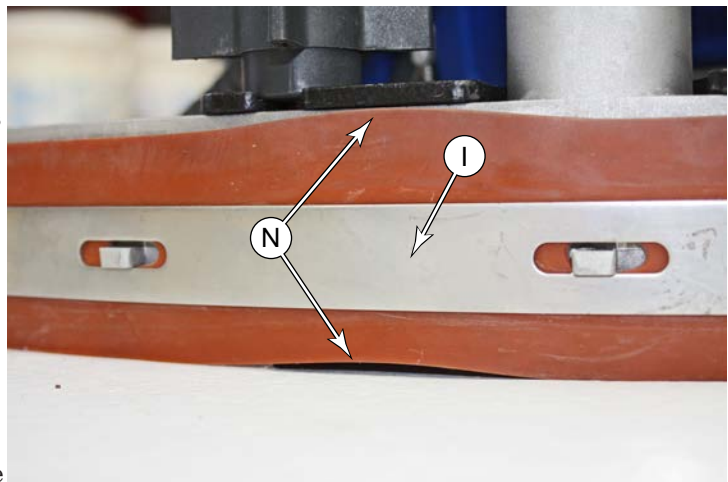

Squeegee Trim Adjustment

The squeegee trim adjustment ensures that the squeegee frame is level with the floor when the squeegee is in the lowered, operating position. If the trim is out of adjustment, the squeegee can leave streaks of water at either the center or the edges of the squeegee.

1. If this procedure is not being performed as a follow-up to replacing the squeegee blade(s), then make the blade examinations described on [page 57](#) beginning with [step 16](#).
2. With the machine parked on a level surface, lower the squeegee to the floor.
3. Examine the contact area between the squeegee blades and the floor. The squeegee blades should be in even contact with the floor.
 - A small bubble level (**B**) may be used to set the frame of the squeegee to be level with the floor.

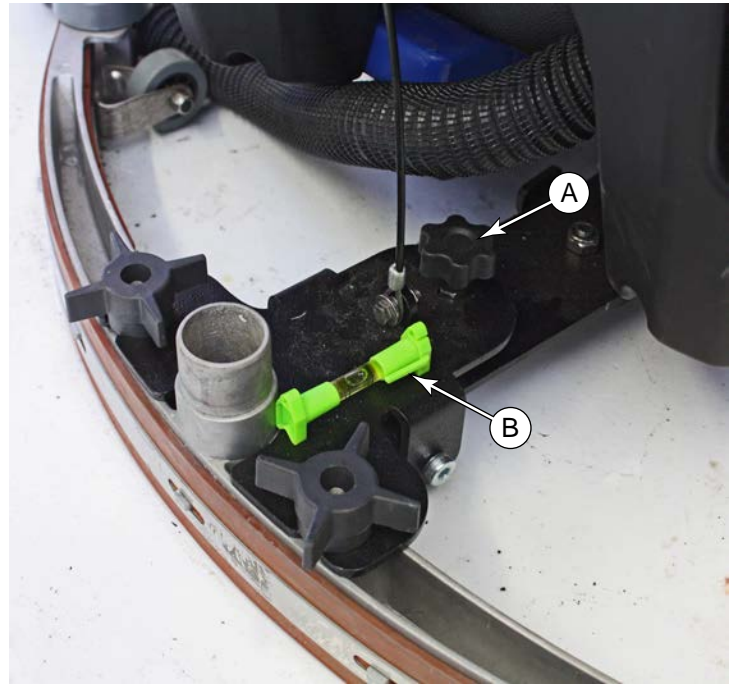

4. If the squeegee is tilted up, there will be a gap at the center, and the level's bubble will be toward the rear of the machine.
 - Turn the adjustment knob (**A**) counterclockwise.

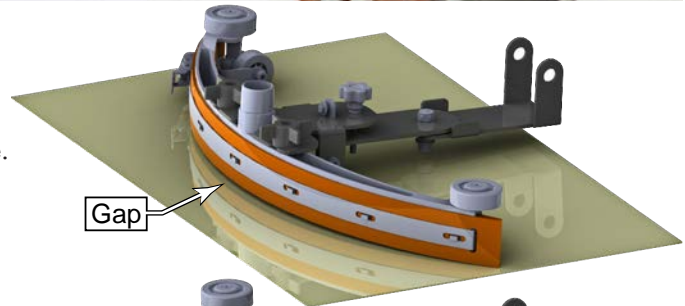

5. If the squeegee is tilted down, there will be a gap at the outsides of the squeegee, and the level's bubble will be toward the front of the machine.
 - Turn the adjustment knob (**A**) clockwise.

