



Electronic Service Manuals

This electronic document is provided as a service to our customers. We do not create the contents of the information contained in this document. Should you have detailed questions pertaining to the information contained in this document, you may contact Michco, or the manufacturer which provided the original information in this electronic deliverable. Michco's only part in this electronic deliverable was the electronic assembly process. By providing this manual on line we are not guaranteeing parts availability.

You may contact Michco through the following methods:

Phone (517) 484-9312 or (800) 331-3339

2011 N. High St. -- Lansing, Michigan -- 48906

Fax: (517) 484-9836

Email: CustServe@Michco.com

Web site: www.Michco.Com

Parts Web site: www.FloorMachineParts.Com

Order Parts on Line at:

www.FloorMachineParts.Com

Directly to Parts & Service:

By Email: **Shop@Michco.com**

By Fax: (517) 702-2041

By Voice: Use numbers above.

Serving the Cleaning Industry Since 1922

Notice: All copyrighted material remains property of original owners, all trademarks are property of respective owners. Manuals are subject to Manufacturer's reproduction limitations. Originals or reproductions were provided by manufacturers through a request. We make no warranty as to the correctness of information provided in this document and you assume all risk. By placing these manuals on line we are not declaring our corporation to be an manufacturer authorized dealer or provider, please check our web site for authorized manufacturers we represent.

Clarke Focus II Midsize **Nilfisk-Alto SCRUBTEC 8/BOOST 8**

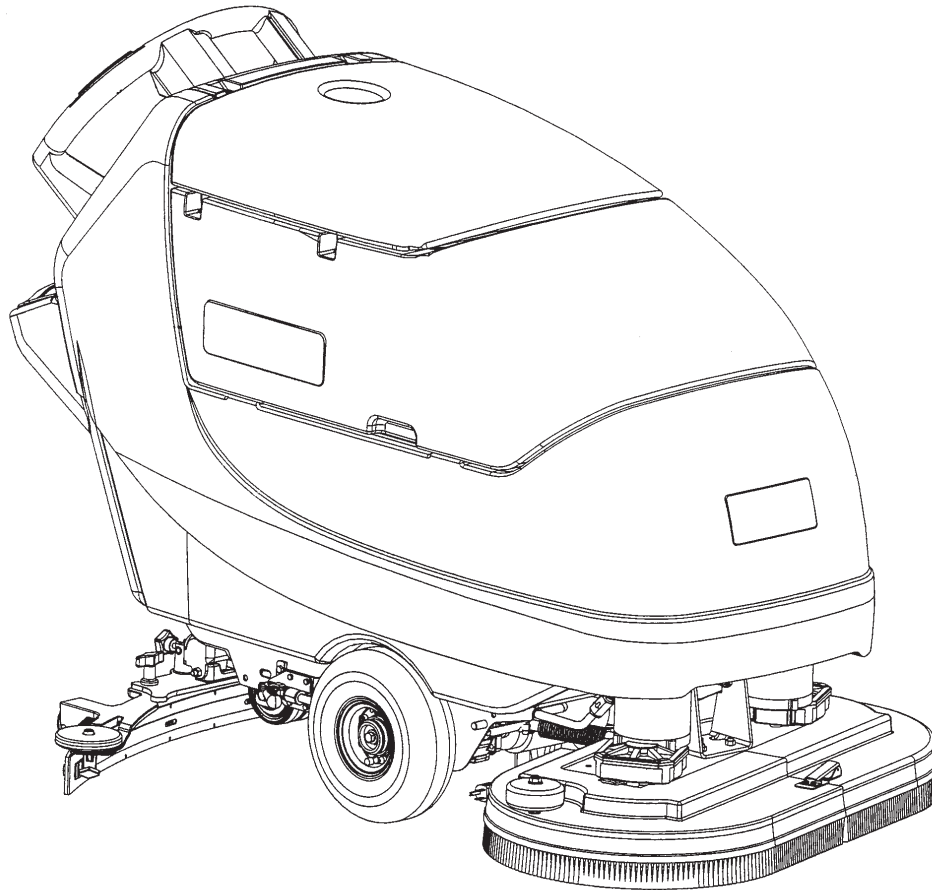

Service Manual

Clarke Models: Disc 26 05390A, Disc 26 05390C, Disc 28 05400A, Disc 28 05400C, Disc 34 05410A, Disc 34 05410C, Cylindrical 28 05420A, Cylindrical 28 05420C, Boost 28 05370A, Boost 28 05370C, Boost 32 05380A, Boost 32 05380C

Nilfisk Alto Models:

Scrubtec 866, 871, 871C, 886, BOOST 8

Nilfisk
ALTO
works for you

Clarke[®]

Contents

GENERAL INFORMATION.....	4
SERVICE MANUAL PURPOSE	4
REVISION HISTORY	4
OTHER REFERENCE MANUALS	4
CONVENTIONS.....	4
SAFETY	4
MACHINE LIFTING.....	5
MACHINE TRANSPORTATION	5
GENERAL INSTRUCTIONS	5
GENERAL MACHINE DESCRIPTION	7
NAMEPLATE.....	7
KNOW YOUR MACHINE	8
INDICATOR LIGHTS.....	10
MACHINE SPECIFICATIONS.....	11
MACHINE MAINTENANCE.....	15
CHASSIS SYSTEM.....	16
FUNCTIONAL DESCRIPTION.....	16
CONTROL SYSTEM.....	17
FUNCTIONAL DESCRIPTION.....	17
COMPONENT LOCATIONS	17
TROUBLESHOOTING	17
REMOVAL AND INSTALLATION.....	21
ELECTRICAL SYSTEM.....	23
FUNCTIONAL DESCRIPTION.....	23
On-board Battery Charger.....	23
COMPONENT LOCATIONS	25
MAINTENANCE AND ADJUSTMENTS	27
CHECKING BATTERY TYPE SETTING	27
TROUBLESHOOTING	30
REMOVAL AND INSTALLATION.....	30
SPECIFICATIONS.....	35
WIRING DIAGRAM – 05370T-E REV F Sheet 1 of 2.....	36
CONNECTION DIAGRAM 05370T-W REV C.....	38
OPTIONS AND ACCESSORIES	39
POWER WAND.....	39
HOUR METER	41
PARKING BRAKE KIT.....	41
CLARKE BATTERY MAINTENANCE SYSTEM.....	42
RECOVERY SYSTEM.....	43
FUNCTIONAL DESCRIPTION.....	43
COMPONENT LOCATIONS	44
TROUBLESHOOTING	47
REMOVAL AND INSTALLATION.....	48
SPECIFICATIONS.....	50

SPECIAL TOOLS	50
SCRUB SYSTEM, CYLINDRICAL	51
FUNCTIONAL DESCRIPTION.....	51
COMPONENT LOCATIONS	53
TROUBLESHOOTING	54
REMOVAL AND INSTALLATION.....	54
SPECIFICATIONS.....	56
SCRUB SYSTEM, DISC	57
FUNCTIONAL DESCRIPTION.....	57
COMPONENT LOCATIONS	59
TROUBLESHOOTING	60
REMOVAL AND INSTALLATION.....	60
SPECIFICATIONS.....	67
SCRUB SYSTEM, ORBITAL (BOOST).....	68
FUNCTIONAL DESCRIPTION.....	68
COMPONENT LOCATIONS	70
TROUBLESHOOTING	71
REMOVAL AND INSTALLATION.....	71
SPECIFICATIONS.....	82
SOLUTION SYSTEM	83
FUNCTIONAL DESCRIPTION.....	83
COMPONENT LOCATIONS	86
MAINTENANCE AND ADJUSTMENTS	90
TROUBLESHOOTING	91
REMOVAL AND INSTALLATION.....	92
WHEEL SYSTEM, NON-TRACTION	95
FUNCTIONAL DESCRIPTION.....	95
COMPONENT LOCATIONS	95
WHEEL SYSTEM, TRACTION.....	96
FUNCTIONAL DESCRIPTION.....	96
COMPONENT LOCATIONS	99
TROUBLESHOOTING	100
REMOVAL AND INSTALLATION.....	101

GENERAL INFORMATION

SERVICE MANUAL PURPOSE

This Service Manual is a resource for professional service technicians. It provides information for understanding how the machine operates, where components are located, basic troubleshooting, maintenance and mechanical service operations.

REVISION HISTORY

- 11/13
 - Electrical System: Update Wiring Diagram 05370T-E from Rev. B to D
- 08/14
 - Electrical System: Update Wiring Diagram 05370T-E and Connection Diagram 05370T-W
 - Add information related to introduction of Delta-Q battery charger

OTHER REFERENCE MANUALS

Operator's Manual (Includes Parts List Information) - Form Number 71483A

CONVENTIONS

Forward, backward, front, rear, left or right are intended with reference to the operator's position, that is to say in driving position with the hands on the handlebar.

SAFETY

The following symbols indicate potentially dangerous situations. Always read this information carefully and take all necessary precautions to safeguard people and property.

SYMBOLS



DANGER!

It indicates a dangerous situation with risk of death for the operator.



WARNING!

It indicates a potential risk of injury for people or damage to objects.



CAUTION!

It indicates a caution related to important or useful functions.
Pay careful attention to the paragraphs marked by this symbol.

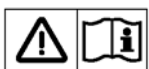

CONSULTATION

It indicates the necessity to refer to the Operator's Manual before performing any procedure.

MACHINE LIFTING



WARNING!

Do not work under the lifted machine without supporting it with safety stands.

MACHINE TRANSPORTATION



WARNING!

Before transporting the machine, make sure that:

- All covers are closed.
- The ignition key is removed.
- The machine is securely fastened to the means of transport.

GENERAL INSTRUCTIONS

Specific warnings and cautions to inform about potential damages to people and machine are shown below.

DANGER!

- Before performing any maintenance, repair, cleaning or replacement procedure disconnect the battery connector and remove the ignition key.
- This machine must be used by properly trained operators only. Children or disabled people cannot use this machine.
-  • Keep the battery away from sparks, flames and incandescent material. During the normal operation explosive gases are released.
- Do not wear jewels when working near electrical components.
- Do not work under the lifted machine without supporting it with safety stands.
- Do not operate the machine near toxic, dangerous, flammable and/or explosive powders, liquids or vapors.
- Battery charging produces highly explosive hydrogen gas. Keep the tank assembly open during battery charging and perform this procedure in well-ventilated areas and away from naked flames.

WARNING!

- Carefully read all the instructions before performing any maintenance/repair procedure.
- Before using the battery charger, ensure that frequency and voltage values, indicated on the machine serial number plate, match the electrical mains voltage.
- Do not pull or carry the machine by the battery charger cable and never use the battery charger cable as a handle. Do not close a door on the battery charger cable, or pull the battery charger cable around sharp edges or corners. Do not run the machine on the battery charger cable.
- Keep the battery charger cable away from heated surfaces.
- Do not charge the batteries if the battery charger cable or the plug are damaged. If the machine is not working as it should, has been damaged, left outdoors or dropped into water, return it to the Service Center.
- To reduce the risk of fire, electric shock, or injury, do not leave the machine unattended when it is plugged in. Before performing any maintenance procedure, disconnect the battery charger cable from the electrical mains.
- Do not smoke while charging the batteries.
- To avoid any unauthorized use of the machine, remove the ignition key (if equipped).

Service Manual: Clarke Focus II Midsize, Nilfisk-Alto ScrubTec

- Do not leave the machine unattended without being sure that it cannot move independently.
- Always protect the machine against the sun, rain and bad weather, both under operation and inactivity condition. Store the machine indoors, in a dry place: This machine must be used in dry conditions; it must not be used or kept outdoors in wet conditions.
- Before using the machine, close all doors and/or covers.
- Do not allow to be used as a toy. Close attention is necessary when used near children.
- Use only as shown in this Manual. Use only factory recommended accessories.
- Take all necessary precautions to prevent hair, jewels and loose clothes from being caught by the machine moving parts.
- Do not use the machine on slopes with a gradient exceeding the specifications.
- Do not use the machine in particularly dusty areas.
- While using this machine, take care not to cause damage to people or objects.
- Do not bump into shelves or scaffoldings, especially where there is a risk of falling objects.
- Do not put any can containing fluids on the machine.
- The machine operating temperature must be between +32°F and +104°F (0°C and +40°C).
- The machine storage temperature must be between +32°F and +104°F (0°C and +40°C).
- The humidity must be between 30% and 95%.
- When using floor cleaning detergents, follow the instructions on the labels of the detergent bottles.
- To handle floor cleaning detergents, wear suitable gloves and protections.
- Do not use the machine as a means of transport.
- Do not allow the brushes to operate while the machine is stationary to avoid damaging the floor.
- In case of fire, use a powder fire extinguisher, not a water one.
- Do not tamper with the machine safety guards and follow the ordinary maintenance instructions scrupulously.
- Do not allow any object to enter into the openings. Do not use the machine if the openings are clogged. Always keep the openings free from dust, hairs and any other foreign material which could reduce the air flow.
- Do not remove or modify the plates affixed to the machine.
- In case the machine should be manually pushed for servicing (no batteries, discharged batteries, etc.) do not exceed 4 km/h speed.
- This machine cannot be used on roads or public streets.
- Pay attention during machine transportation when temperature is below freezing point. The water in the recovery tank or in the hoses could freeze and seriously damage the machine.
- Use brushes and pads supplied with the machine and those specified in the Operator's Manual. Using other brushes or pads could reduce safety.

- In case of machine malfunctions ensure that these are not caused by a lack of maintenance. Otherwise, request assistance from the authorized personnel or from an authorized Service Center.
- Use brushes and pads supplied with the machine and those specified in the Operator's Manual. Using other brushes or pads could reduce safety.
- In case of machine malfunctions ensure that these are not caused by a lack of maintenance. Otherwise, request assistance from the authorized personnel or from an authorized Service Center.
- If the machine does not work properly, is damaged, has water or foam leaks, has been left outdoors exposed to bad weather conditions, is wet or has been dropped into water, turn it off immediately and contact an authorized service center or a qualified technician.
- If parts must be replaced, require ORIGINAL spare parts from an Authorized Dealer or Retailer.
- To ensure machine proper and safe operation, the scheduled maintenance shown in the relevant chapter of this Manual, must be performed by the authorized personnel or by an authorized service center.
- Carefully read all the instructions before performing any maintenance/repair procedure.
- Do not wash the machine with direct or pressurized water jets, or with corrosive substances.
- The machine must be disposed of properly, because of the presence of toxic-harmful materials (batteries, etc.).

GENERAL MACHINE DESCRIPTION

The Clarke Focus II Midsize scrubber is a battery powered walk behind floor scrubber designed to clean flat hard surfaces. It is a 24 volt system. It has one controller that operates the scrub and vacuum functions and another that operates the drive system. It can have a "disc" type of scrub deck, "cylindrical" or "boost"™.

NAMEPLATE

The nameplate contains important identification information which will be needed when ordering parts: Model description, Code, and Serial Number.



KNOW YOUR MACHINE

MACHINE CONTROL PANEL

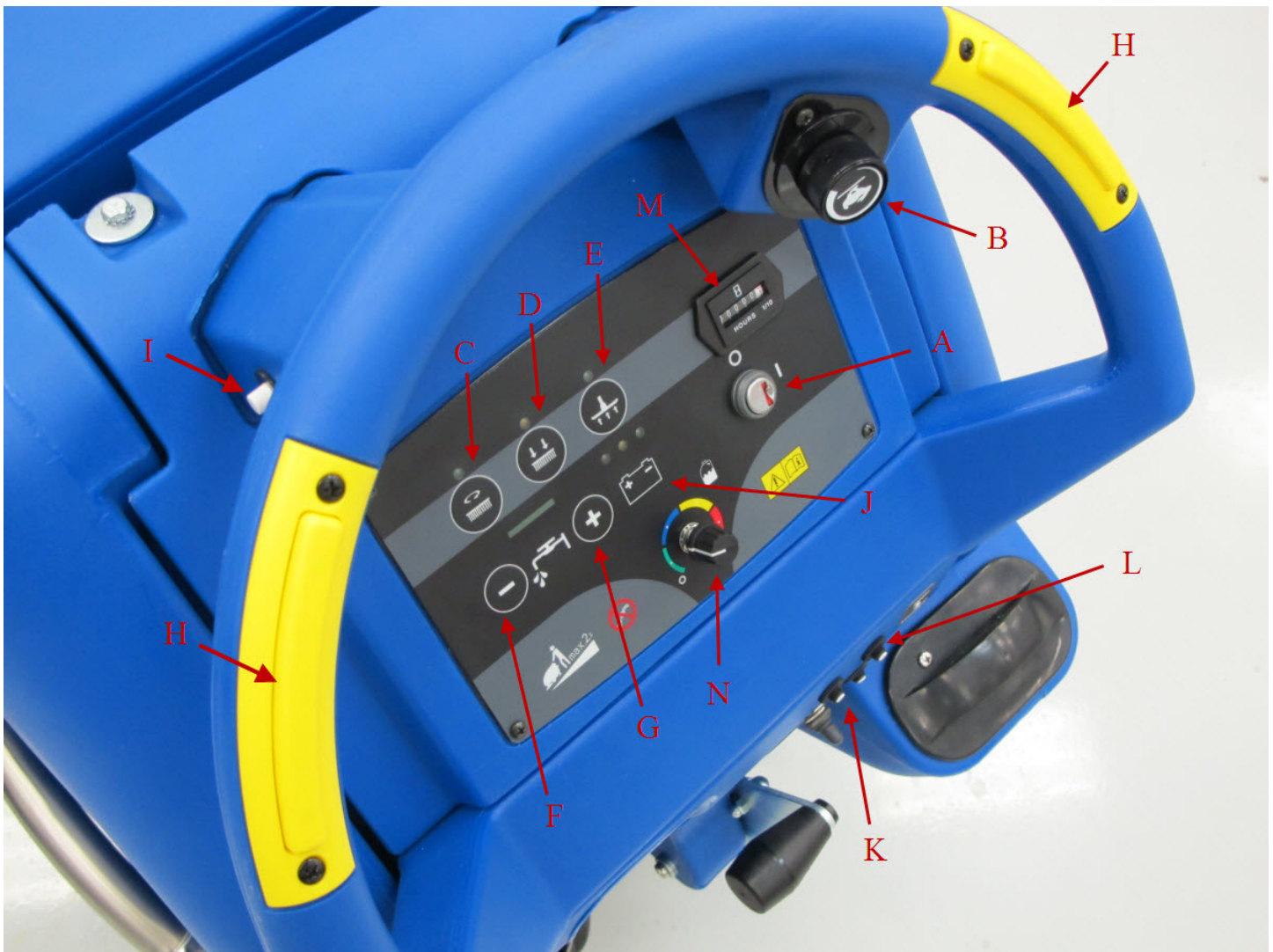

Figure 1 – Machine Control Panel

Key Switch (See Figure 1, Item “A”) The key switch turns “ON” the power to the control panel. “O” is “OFF” and “I” is “ON”.

Traverse Speed Switch (Speed Control Potentiometer) (See Figure #1, Item “B”) The speed control varies from low to high speed. To increase the speed, turn the knob to the right. To decrease the speed, turn the knob to the left.

One Touch Control Button (See Figure 1, Item “C”) The one touch control button raises and lowers the brush head assembly, starts and stops the vacuum motor automatically. Press the one touch control button once and the brush head assembly lowers to the floor and the vacuum motor turns “ON” (brush head and vacuum LEDs illuminate green). The brush motors start when the brushes are down and the forward palm button is depressed. Press the one touch control button again and the brush head assembly raises, the vacuum motor will remain on for 10 seconds and then shut “OFF”.

Increase Brush Pressure Button (See Figure 1, Item D) This button is used to increase the brush pressure. Increased brush pressure may be required when stripping or cleaning heavily soiled floors. To increase brush pressure, first

lower the brushes by pressing the one touch control button (Item “C”). This will lower the brushes to the normal scrub position. To increase brush pressure, press the button (Item “D”). The LED above the button will illuminate yellow. Press the button (Item “D”) again and the brushes will return to normal scrub (yellow LED will turn “OFF”). NOTE: Increase brush pressure is not available on cylindrical machine.

Vacuum Motor Button (See Figure 1, Item “E”) The vacuum motor button turns the vacuum motor “ON” or “OFF”, regardless of brush head assembly position. The green LED will illuminate when the vacuum motor is “ON”.

Solution Control Buttons (See Figure 1, Item “F & G”) The solution control buttons regulate the flow of cleaning solution to the floor. The normal scrub solution setting is indicated by two green bars on the meter. On cylindrical machines, with most floor conditions, the solution setting should be set one step higher. To increase the flow, press the solution flow button “G” (+) until the desired flow is reached. To decrease the flow, press the solution flow button “F” (-) until the desired flow is reached. To shut off the solution, press the solution flow button “F” (-) until no indicators are visible on the display. NOTE: No solution will flow when the machine does not traverse.

Forward Palm Buttons (Forward Switches) (See Figure 1, Item “H”) The forward palm buttons turn the traverse motor “ON” and if the brush motors are in the down position, it also activates the brush motors and solution control module. Either the right or the left palm button can be used.

Reverse Push Button (Reverse Switch) (See Figure 1, Item “I”) The reverse push button, when used in conjunction with one of the forward palm buttons, causes the machine to reverse direction. The reverse speed is 67% of the forward speed.



Charge / Battery Meter (See Figure 1, Item “J”) The charge / battery meter indicates the battery is being charged when the charger is plugged into an AC outlet. It also indicates the amount of charge that is left in the batteries while the machine is in use. When the charge gets too low the brush/pad motors will shut off.

Circuit Breakers (See Figure 1, Item “K & L”) The circuit breakers for the brush motors are located on the control panel. If a circuit breaker trips, determine which motor is not operating and turn the key switch “OFF”. Wait five minutes and push the reset button back in. Turn the key switch “ON”, and try again. An authorized service person should be contacted if the breaker trips again.

Hour Meter (Optional) (See Figure 1, Item “M”) The hour meter indicates the number of hours the machine has operated. It runs only when the machine is moving forward or reverse. The image shows where the hour meter would be installed if it were equipped with one.

Chemical Mixing Control (Optional) (See Figure 1, Item “N”) The chemical mixing control regulates the amount of concentration of cleaning chemical mixed with the clear water from the solution tank. Turning the chemical mixing knob clockwise increases the concentration of chemical.

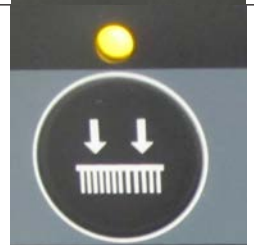
INDICATOR LIGHTS

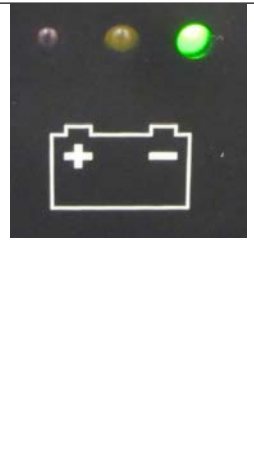
Indicator Light	Explanation
	<ul style="list-style-type: none"> On steady when operator has requested one touch scrub. Flashes when brush head actuator is moving. Does not come on at initial key on.
	<ul style="list-style-type: none"> On steady when operator has requested extra scrub pressure . Flashes when brush head actuator is moving. Does not come on at initial key on.
	<ul style="list-style-type: none"> On steady when vacuum is on. Flashes when scrub has been turned off and timer is running before vacuum is shut off. Does not come on at initial key on.
	<ul style="list-style-type: none"> Indicates solution flow rate requested by operator. First two segments on = low flow rate (This is default when first turning on machine). First 4 segments on = medium flow rate. All 6 segments on = high flow rate. No segment on = solution flow off. Also used when setting battery type - See relevant section of manual.
	<ul style="list-style-type: none"> Indicates battery charge condition . Green = Fully charged . Yellow = Partial charge . Flashing Yellow Indicator = Actuator fault Indication. Disables scrub and vacuum functions. See CONTROL SYSTEM for more information. Flashing Red Indicator = Low voltage cut out mode. See ELECTRICAL SYSTEM, Specifications for more information. At first key on, one of the three battery indicator lights will flash to indicate what battery type setting is stored. See CHECKING BATTERY TYPE SETTING section of manual.

MACHINE SPECIFICATIONS

Model	DISC 26	Disc 28	Disc 34
Pad / Brush Size	(2) 13" (33 cm)	(2) 14" (36 cm)	(2) 17" (43 cm)
Brush Motor (s)	(2) 3/4 hp (.56 kw) 200 RPM	(2) 3/4 hp (.56 kw) 200 RPM	(2) 3/4 hp (.56 kw) 200 RPM
Cleaning Width	26" (66 cm)	28" (71 cm)	34" (86.4 cm)
Brush Pressure	1st - 80 lbs. (36 kg) 2nd - 150 lbs. (68 kg)	1st - 80 lbs. (36 kg) 2nd - 150 lbs. (68 kg)	1st - 80 lbs. (36 kg) 2nd - 150 lbs. (68 kg)
Brush Retention	Gimbal	Gimbal	Gimbal
Brush Head Water Retention	Steel Deck w/ Bristle Skirt	Steel Deck w/ Bristle Skirt	Steel Deck w/Bristle Skirt
Squeegee Width	32.5" (81 cm)	35" (89 cm)	41" (107 cm)
Width of Machine	28" (71 cm) Head 23.5" (60 cm) Body	30" (76 cm) Head 23.5" (60 cm) Body	35.7" (91 cm) Head 23.5" (60 cm) Body
Length of Machine	61" (155 cm)	62" (157 cm)	64" (162 cm)
Height of Machine	44" (112 cm)	44" (112 cm)	44" (112 cm)
Weight w/250 Ah batteries and full solution tank	796 lbs. (361.1 kg)	800 lbs. (362.9 kg)	791 lbs. (358.8 kg)
Power Supply	24 volt, (4 - 6 volt batteries) 242 AH or 310 AH, Plus AGMs		
Vacuum Motor	.75 hp (550W), 3 stage, tangential discharge		
Vacuum Motor Protection	Electronic Float Shut-Off		
Solution Tank	23 gallons (87 liters)		

Service Manual: Clarke Focus II Midsize, Nilfisk-Alto ScrubTec

Model	DISC 26	Disc 28	Disc 34
Solution Fill	Rear Fill with Bucket or Hose		
Solution Flow	0 - 1 gal/min (0 - 3.8 liters/min)		
Recovery Tank	23 gallons (87 liters)		
Motor Traction	.44 hp (.33 kw)		
Speed Forward	0 - 260 ft/min (0 - 4.8 km/h)		
Speed Reverse	0 - 174 ft/min (0 - 3.2 km/h)		
Drive Wheel	(2) 10.24" (260 mm) x 3.35" (85 mm) Light Gray, Non-Marking, Foam Filled		
Caster Wheel	(2) 3.94" (10 cm) Polyurethane		
Squeegee Material	Urethane Front Blade and Rear Blade		
Cleaning Grade	6 degree incline		
Charger	On Board, 24 volt, 25 amp		
Vibration @ handle	<2.5m/s ²		
Sound test @ operator's ear	65 dBA	65 dBA	67 dBA

Model	Cylindrical 28	BOOST 28	BOOST 32
Pad / Brush Size	(2) 5.75" x 28" (14.6 x 69cm)	14" x 28" (35.6 x 71cm)	14" x 32" (35.6 x 81cm)
Brush Motor (s)	(2) .81 hp (.6 kw) 613 RPM	3/4 hp (.56 kw) 2250 RPM	3/4 hp (.56 kw) 2250 RPM
Cleaning Width	28" (71 cm)	28" (71 cm)	32" (81 cm)
Brush Pressure	80 lbs. (36 kg)	1st - 65 lbs. (29.5 kg) 2nd - 125 lbs. (56.7 kg)	1st - 95 lbs. (43 kg) 2nd - 150 lbs. (68 kg)
Brush Retention	N/A	Hook & Loop	Hook & Loop
Brush Head Water Retention	Side Skirts	N/A	N/A
Squeegee Width	35" (89 cm)	35" (89 cm)	41" (107 cm)
Width of Machine	30.69" (78 cm) Head 23.5" (60 cm) Body	28.75" (73 cm) Head 23.5" (60 cm) Body	32.75" (83 cm) Head 23.5" (60 cm) Body
Length of Machine	59.5" (151 cm)	60.5" (154 cm)	60.5" (154 cm)
Height of Machine	44" (112 cm)	44" (112 cm)	44" (112 cm)
Weight w/250 Ah batteries and full solution tank	792 lbs. (359.3 kg)	794 lbs. (360.2 kg)	822 lbs. (372.9 kg)
Power Supply	24 volt, (4 - 6 volt batteries) 242 AH or 310 AH, Plus AGMs		
Vacuum Motor	.75 hp (550W), 3 stage, tangential discharge		
Vacuum Motor Protection	Electronic Float Shut-Off		
Solution Tank	23 gallons (87 liters)		
Solution Fill	Rear Fill with Bucket or Hose		

Service Manual: Clarke Focus II Midsize, Nilfisk-Alto ScrubTec

Model	Cylindrical 28	BOOST 28	BOOST 32
Solution Flow	0 - 1 gal/min (0 - 3.8 liters/min)	Normal BOOST Scrubbing .12 gal/min (.45 liters/min), Full range .0 - .65 gal/min (0 -2.5 liters/min)	
Recovery Tank	23 gallons (87 liters)		
Motor Traction	.44 hp (.33 kw)		
Speed Forward	0 - 260 ft/min (0 - 4.8 km/h)		
Speed Reverse	0 - 174 ft/min (0 - 3.2 km/h)		
Drive Wheel	(2) 10.24" (260 mm) x 3.35" (85 mm) Light Gray, Non-Marking, Foam Filled		
Caster Wheel	(2) 3.94" (10 cm) Polyurethane		
Squeegee Material	Urethane Front Blade and Rear Blade		
Cleaning Grade	6 degree incline		
Charger	On Board, 24 volt, 25 amp		
Vibration @ handle	<2.5m/s ²		
Sound test @ operator's ear	71 dBA	63 dBA	63 dBA

MACHINE MAINTENANCE

EVERY 6 MONTHS

1. Check the carbon brushes in the electric motors.
 - a. Scrub motors for all disc and boost models (not cylindrical).
 - b. Transaxle motor.
2. Clean the battery terminals and connectors. Make sure all of the battery connections are tightened correctly.
3. Check all of the switches, controls, valves, hoses and gaskets.
4. Check and remove debris from the transaxle hubs.

BOOST ONLY

SEVERE DUTY – EVERY 500 HOURS

1. Replace the rubber isolators. The rubber isolators are considered wear items and must be replaced. (See relevant section for Remove and Replace instructions)
2. Replace the rubber mounts. The rubber mounts are considered wear items and must be replaced. (See relevant section for Remove and Replace instructions)

NORMAL DUTY EVERY 6 MONTHS

1. Replace the rubber isolators. The rubber isolators are considered wear items and must be replaced.
2. Replace the rubber mounts. The rubber mounts are considered wear items and must be replaced.

CHASSIS SYSTEM

FUNCTIONAL DESCRIPTION

The chassis is made up of heavy gauge steel and supports the drive transaxle, caster wheel, brush deck, squeegee assembly and machine body.

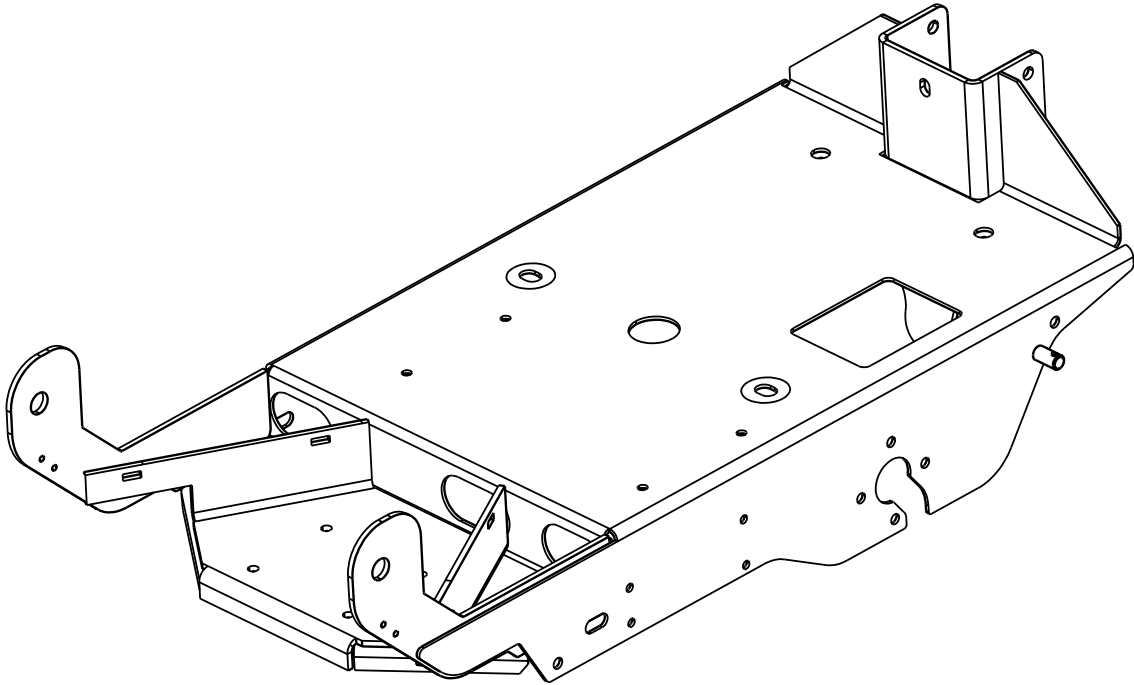

CONTROL SYSTEM

FUNCTIONAL DESCRIPTION

There are two controllers on the Clarke Focus II midsize scrubber. The main machine controller operates the scrub and vacuum functions. It is located directly behind the operator control panel. It is responsible for raising and lowering the deck, turning the scrub function and the vacuum function on and off based on operator requests and other inputs. The main machine controller continuously monitors the brush head actuator position switches whenever the key switch is on for a “legal combination” of inputs. If it sees an illegal combination (more than one switch circuit open at the same time), the yellow battery indicator light will flash and both the scrub and vacuum functions will be immediately disabled. See relevant sections for more detailed descriptions of how the main controller operates each machine system. There is a separate Drive Motor Controller that operates the traction drive system based on operator requests. (See the section on Wheel System, Drive for more information)

COMPONENT LOCATIONS

MAIN MACHINE CONTROLLER

The main machine controller is on the back side of the operator control panel



TROUBLESHOOTING

FAULT CODE INDICATOR

The yellow battery indicator light also serves as a fault indicator. The main machine controller continuously monitors the brush head actuator position switches whenever the key switch is on for a “legal combination” of inputs. If it sees an illegal combination (more than one switch circuit open at the same time – 5v signal), the yellow battery indicator light will flash and both the scrub and vacuum functions will be immediately disabled.

MAIN MACHINE CONTROLLER ELECTRICAL CONNECTORS

J1 Connector – 12 Pin

Pin ID	Description
J1-1	24Vdc (B+) at all times.
J1-2	Not Used
J1-3	24Vdc with Key Switch "ON". Note: Output from Control Panel to turn "ON" IDrive Relay.
J1-4	17Vdc with Key Switch "ON" and Brush Head lowered to the floor then 0Vdc when the Traverse is engaged Forward or Reverse Direction. Note: Output from IDrive Traverse Controller to turn "ON" Brush Motors.
J1-5	Not Used
J1-6	Not Used
J1-7	Not Used
J1-8	0Vdc (B-) at all times.
J1-9	24Vdc with Key Switch "ON". Note: (+) Output from Control Panel to the (+) Input to the Hour meter, Vacuum Solenoid and Brush Solenoid.
J1-10	24Vdc with Key Switch "ON" then 0Vdc when the Vacuum is selected, unless the Float Switch opens due to a Full Recovery Tank, it will be 0Vdc due to the open Float Switch. Note: Output from Control Panel to turn "ON" Vacuum Solenoid.
J1-11	24Vdc with Key Switch "ON" and Brush Head lowered to the floor then 0Vdc when the Traverse is engaged Forward or Reverse Direction. Note: Output from Control Panel to turn "ON" Brush Motor Solenoid.
J1-12	Not Used

J2 Connector – 4 Pin

Pin ID	Description
J2-1	24Vdc (B+) at all times. Note: Input to Key Switch.
J2-2	24Vdc with Key Switch "ON". Note: Input back from Key Switch.

Pin ID	Description
J2-3	Not Used
J2-4	Not Used

J3 Connector – 16 Pin

Pin ID	Description
J3-1	24Vdc with Key Switch "ON" and Brush Head lowered to the floor and when the Traverse is engaged Forward or Reverse Direction. Note: (+) Output from Control Panel to turn "ON" Solution Valve.
J3-2	0Vdc with Key Switch "ON" and Brush Head lowered to the floor and when the Traverse is engaged Forward or Reverse Direction. Note: (-) Output from Control Panel to turn "ON" Solution Valve.
J3-3	Not Used
J3-4	Not Used
J3-5	Not Used
J3-6	Not Used
J3-7	0Vdc with Key Switch turned "ON". Note: Output from Control Panel to the Head Actuator Internal Limits Switches. No adjustment or repair for limit switches in actuator.
J3-8	5Vdc with Key Switch turned "ON" and the Brush Head Actuator is fully raised. 0Vdc with Key Switch turned "ON" and the Brush Head Actuator is fully lowered. Note: Output from Control Panel to the Head Actuator Internal Limits Switches. No adjustment or repair for limit switches in actuator.
J3-9	0Vdc with Key Switch turned "ON" and the Brush Head Actuator is fully raised. 5Vdc with Key Switch turned "ON" and the Brush Head Actuator is lowered to the normal scrub position. Note: Output from Control Panel to the Head Actuator Internal Limits Switches. No adjustment or repair for limit switches in actuator.
J3-10	0Vdc with Key Switch turned "ON" and the Brush Head Actuator is fully raised and lowered to the normal scrub position. 5Vdc with Key Switch turned "ON" and the Brush Head Actuator is lowered to the maximum scrub position. Note: Output from Control Panel to the Head Actuator Internal Limits Switches. No adjustment or repair for limit switches in actuator.

Pin ID	Description
J3-11	24Vdc with Key Switch "ON" and the Brush Head Actuator is being lowered to the floor or 0Vdc in the opposite direction.
J3-12	0Vdc with Key Switch "ON" and the Brush Head Actuator is being lowered to the floor or 24Vdc in the opposite direction.
J3-13	Not Used
J3-14	Not Used
J3-15	24Vdc in the normal operational mode and 0Vdc when in the Battery Charge Mode. Battery Charger Inhibit.
J3-16	0Vdc in the normal operational mode and 13Vdc when in the Battery Charge Mode. Battery Charger Inhibit.

CONTROL PANEL ON-BOARD FUSES

Fuse ID	Description
Fuse 4	3 Amps DC Low Power Logic Circuits (Automotive Fuse)
Fuse 7	10 Amps DC Brush Head Actuator Circuit (Automotive Fuse)

REMOVAL AND INSTALLATION

MAIN MACHINE CONTROLLER

1. Turn off key, remove control panel mounting screws and pull control panel toward you.

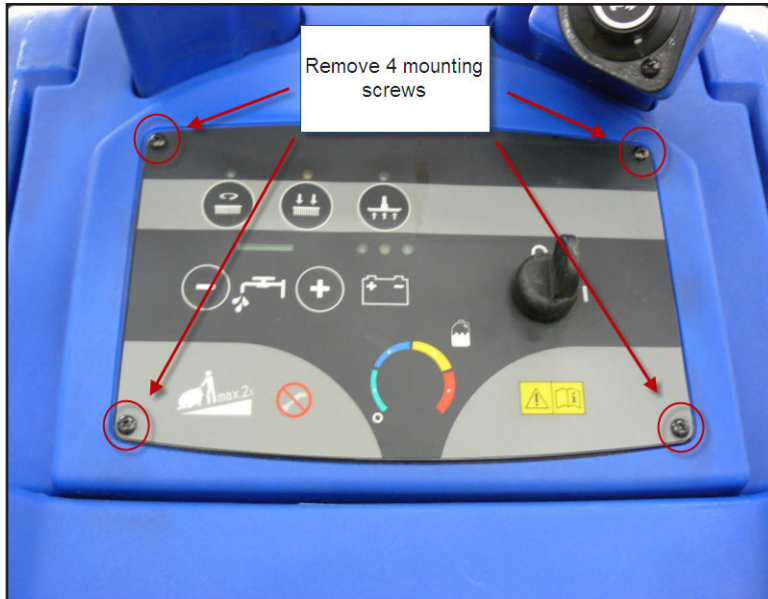

2. Disconnect the 3 white electrical connectors, the 2 green ground wires on the key switch and the wiring for the hour meter (If equipped) and remove the control panel.

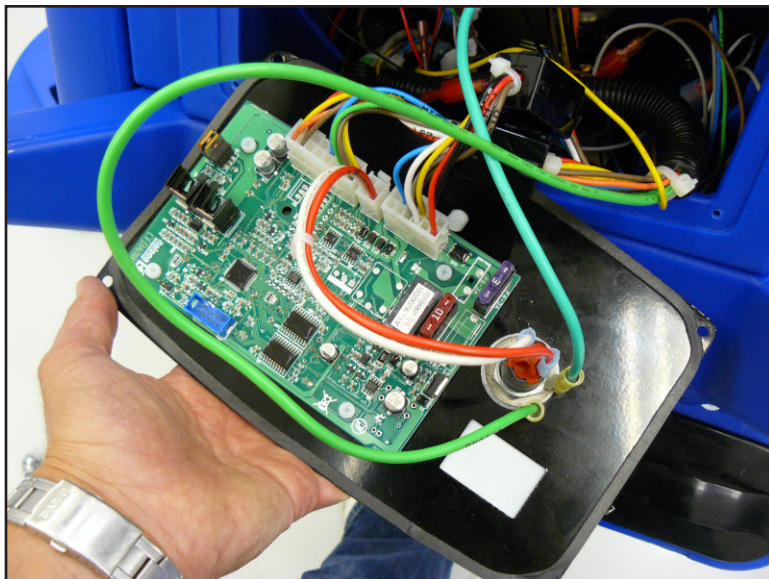

3. Separate the main machine control board from the control panel by removing the 4 white plastic screws.

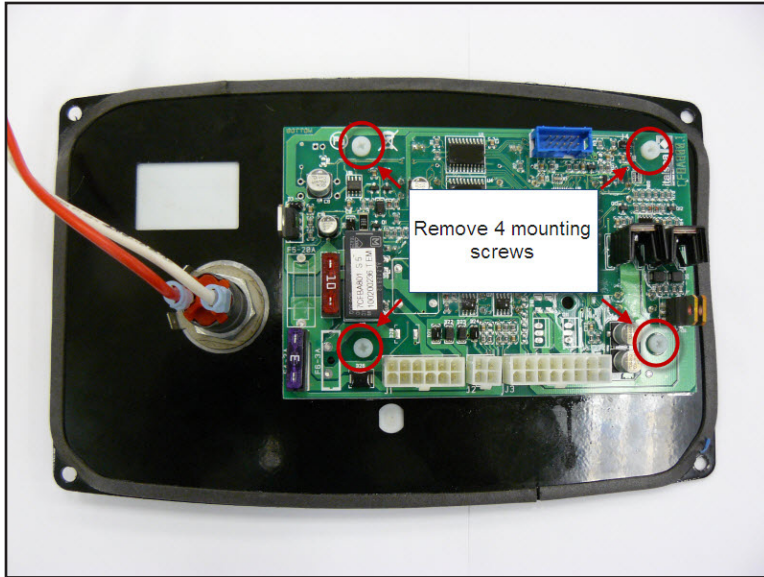

4. Do not lose the plastic film between the control board and the panel.
5. Important: Set the J4 jumper terminals on the back of the board to match the type of scrub deck used. The terminals must be connected for cylindrical scrub head models (This disables the extra pressure button.). The jumper terminals must be disconnected for boost and disc scrub head models (This enables the extra pressure button).

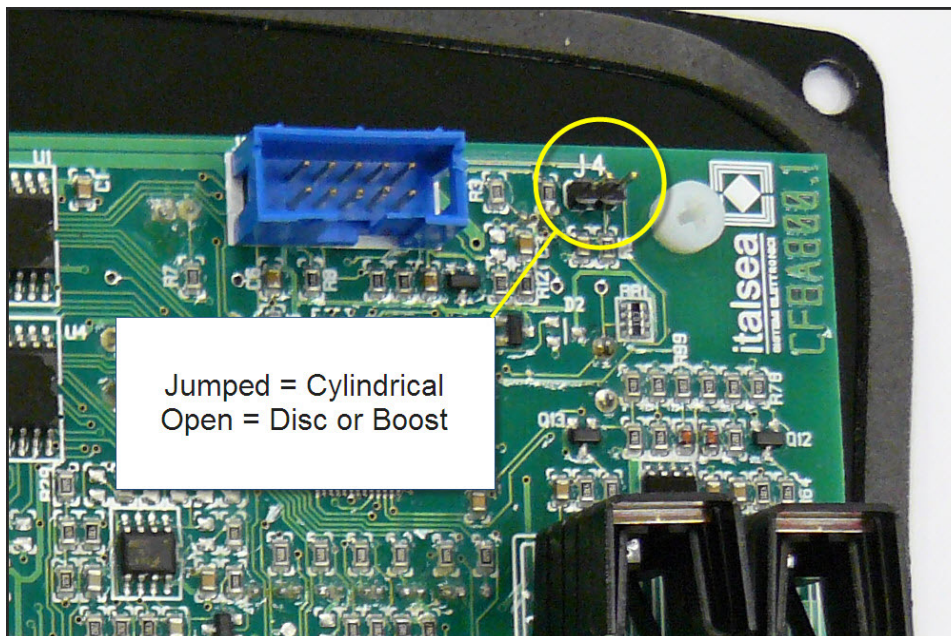

6. Reassemble in reverse order.

ELECTRICAL SYSTEM

FUNCTIONAL DESCRIPTION

The Clarke Focus II Midsize scrubber is battery powered. It contains 4 6 volt batteries for a total of 24volts. Heavy cables connect the batteries in series. A large red 120 amp two way “Anderson” connector is used as a Main Power Plug to connect the batteries to the machine wiring and battery charger. To prevent damage to the batteries due to excessive discharging, the control system will turn off the brush system, vacuum system and finally the drive system as the battery voltage drops too low.

A steel plate at the back of the solution tank serves as an “electrical panel” and provides a mounting surface for the various relays, fuses and the Drive Motor Controller. Circuit breakers and fuses protect various circuits from excessive current. The machine wiring is color coded and the ends of each wire have a functional description printed on them such as “IDrive Relay 30”.

On-board Battery Charger

An optional on-board battery charger is mounted on the bottom of the machine. Early models used an S.P.E. charger and later models use a Delta-Q IC650 charger.

Interlock Circuit

Both types of battery chargers have an “interlock circuit” which consists of an internal relay that interrupts power to the drive wheel speed controller when the charger is plugged into an AC power outlet. This prevents the machine from being propelled while the batteries are charging.

Here is how the battery charger interlock circuit works. The interlock relay contacts inside the charger are normally closed, allowing the current to pass in and out of the charger to the A1 Control Board and the Speed Controller. When the AC power cord is plugged in, the relay is energized and opens the relay contacts opening the circuit.

S.P.E. Charging Profiles and Charging Progress

When the charger is first plugged in, one of the indicator lights will flash out the battery type setting. After that, the red, yellow and green battery charge level indicator lights are used during the charging process to indicate the current charge. When the batteries are fully charged the green light will be on steady.

The S.P.E. battery charger and main machine controller communicate with one another on the yellow wire that runs between them. Each time the battery charger is plugged in the charger contacts the controller by sending out a positive voltage on the communication wire to ask what the battery type setting is. The controller responds and tells it the battery type setting it has stored. The charger then selects the proper charging profile to match the battery type and begins charging the batteries. If the charger is unable to communicate with the controller it will use the profile for a wet battery at a 25 Amp rate as a default.

Delta-Q Charging Profiles and Charging Progress

The Delta-Q battery charger does not communicate with the main machine controller. It is a “stand-alone” unit. Models that have the Delta-Q charger have a separate LED to communicate charging progress. By pressing a button on the charger you can see what charging profile is in use. If you replace the batteries with a different type of battery or replace the battery charger, you must select the correct charging profile to be compatible with the batteries. There are a set of profiles stored inside the charger. You can interface directly with the charger to select the profile to be used from that set. See the Delta-Q IC650 Product Manual (710-0138-Delta-Q.pdf) for complete instructions on selecting the profile. Use the Delta-Q Battery Charging Profile Table below to choose the profile to match the batteries that are in the machine.

Delta-Q IC650 Battery Charging Profiles Table

Battery Manufacturer	Voltage	Battery Model #	20 Hour Rating	N-A P/N	Profile to use
DISCOVER	6	EV250A-AGM	260	40953A	P-0-4-3
DISCOVER	6	EV305A-A	312	56112546	P-0-4-3
DISCOVER	6	EV305A-A	312	56315959	P-0-4-3
DISCOVER	6	EV305A-AGM	312	40964A	P-0-4-3
DISCOVER	6	EVGT6A	255	56112545	P-0-4-3
DISCOVER	6	EVGT6A	255	56315772	P-0-4-3
DISCOVER	6	EVL 16A-A	390	56388582	P-0-4-3
DISCOVER	12	EV12A-A	140	56380239	P-0-4-2
DISCOVER	12	EV185A- A	234	56393912	P-0-4-3
DISCOVER	12	EV185A-A	234	41023A	P-0-4-3
EAST PENN MFG. CO.	6	8GGC 2/T881 (GEL CELL)	180	56206987	P-0-2-6
EAST PENN MFG. CO.	12	8G27MM/T876	86.4	56206988	P-0-2-6
FULL RIVER	6	DC 250-6	250	56112545	P-1-5-1
FULL RIVER	6	DC 335-6	335	56112546	P-1-4-1
TROJAN	6	J -305G	285	56391391	P-0-0-7
TROJAN	6	J-250-2992-41	250	56026200	P-0-0-3
TROJAN	6	L16-5592-41	395	56388582	NOT RECOMMENDED
TROJAN	6	T-125LPT	235	56206079	P-0-0-3
TROJAN	6	T-605LPT	195	56206117	P-0-0-3
TROJAN	12	J185-2292-42	195	56206078	P-0-0-3
US BATTERY	6	L16	375	40602A	P-0-7-3
US BATTERY	6	L16	375	40704A	P-0-7-3
US BATTERY	6	L16HC	415	56388582	P-0-7-3
US BATTERY	6	US-125	235	331318	P-0-1-1
US BATTERY	6	US-125	235	881317	P-0-1-1
US BATTERY	6	US-125	235	56206079	P-0-1-1
US BATTERY	6	US-125	235	40136A	P-0-1-1
US BATTERY	6	US-125	235	40136B	P-0-1-1
US BATTERY	6	US-14 5XC	251	56317154	P-0-7-2
US BATTERY	6	US1800	201	56206117	P-0-1-1
US BATTERY	6	US250HC	275	56026200	P-0-1-1
US BATTERY	6	US-305	305	891384	P-0-7-2
US BATTERY	6	US-305	305	891385	P-0-7-2
US BATTERY	6	US-305	305	56391391	P-0-7-2
US BATTERY	12	UB27	86	40070A	P-0-0-6
US BATTERY	12	US-185	195	871334	P-0-1-1
US BATTERY	12	US-185	195	871335	P-0-1-1
US BATTERY	12	US-185	195	56206078	P-0-1-1
US BATTERY	12	US-31TMX	130	40605A	P-0-7-1
US BATTERY	12	US-31TMX	130	40606A	P-0-7-1

COMPONENT LOCATIONS

- Batteries
- Main Power Plug
- Battery Charger
- Electrical Panel
- Fuses

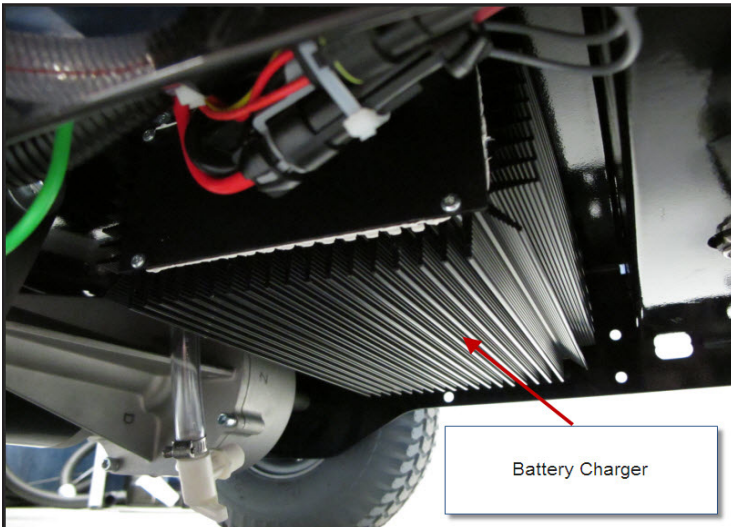
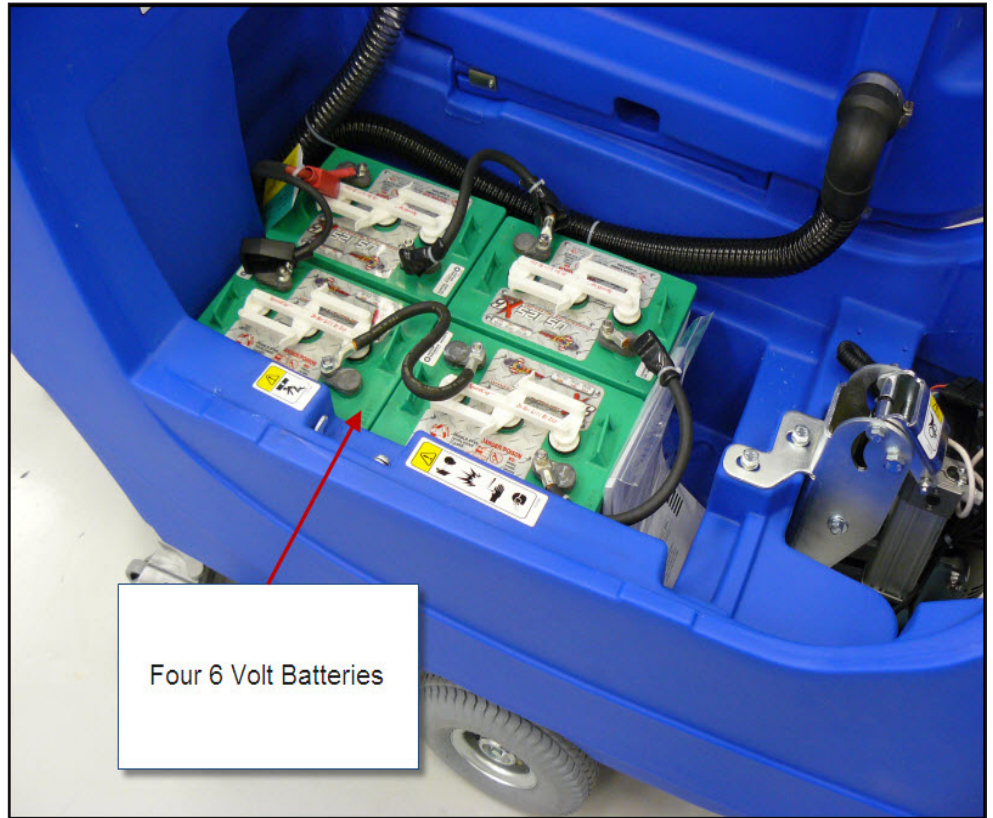

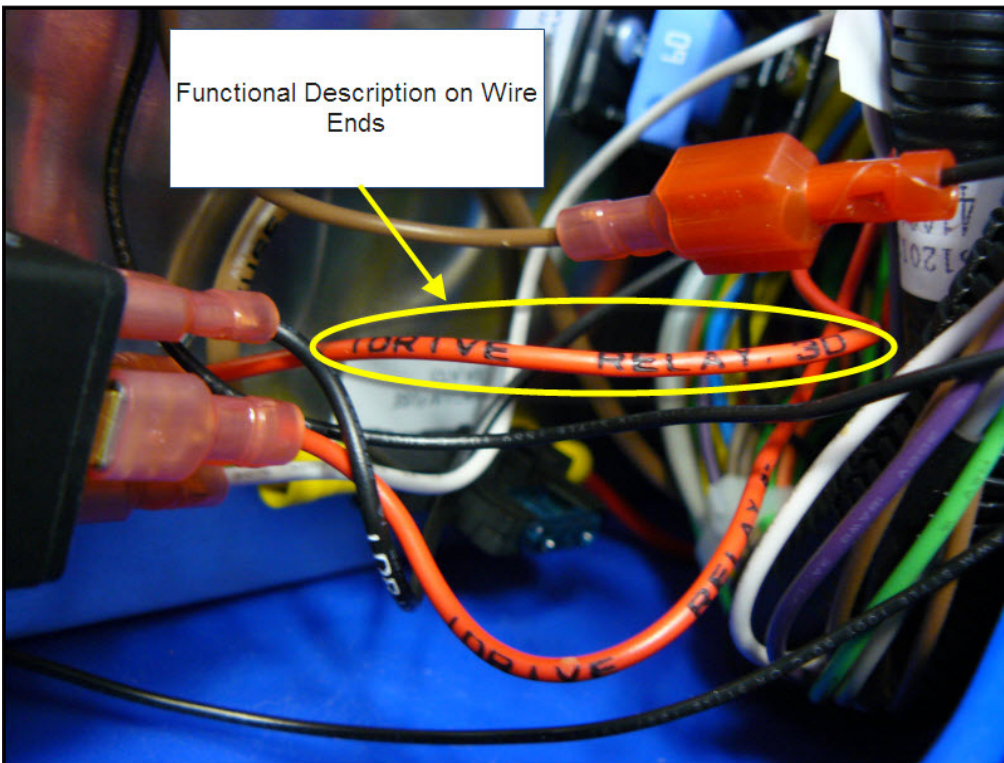
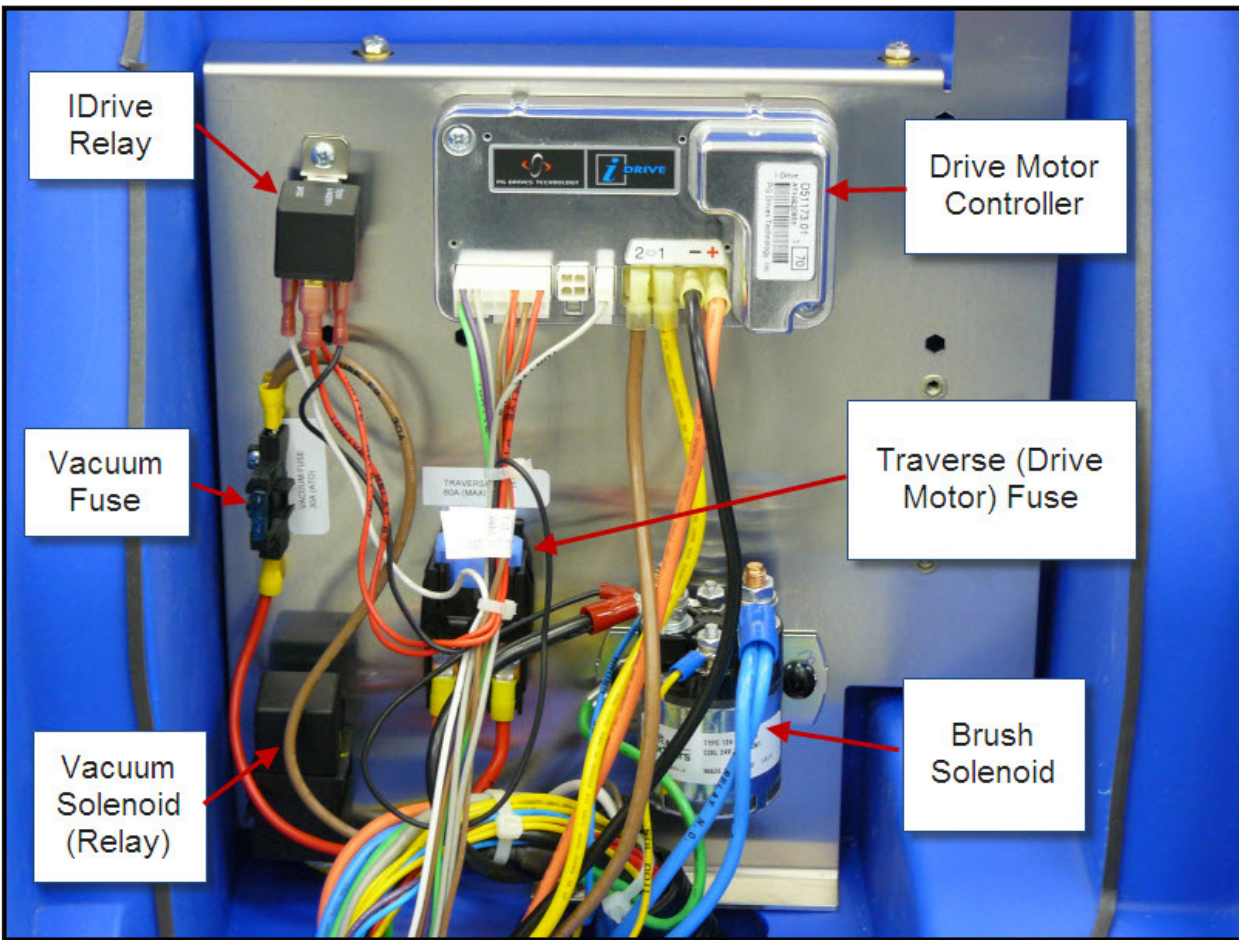

MAINTENANCE AND ADJUSTMENTS

BATTERY MAINTENANCE AND RECHARGING

See Operator's Manual.

CHECKING BATTERY TYPE SETTING

The battery type setting is stored in the main machine controller and is used to establish the correct low voltage cutout threshold and for storing the correct charging profile to be used by the S.P.E battery charger. (The Delta-Q battery charger does not use this information.)

To check the current battery type setting that is stored in the main machine controller, observe the battery indicator lights immediately after turning the key switch on. Make a note of which color light flashes and how many times it flashes.

- Red Light
 - 2 Flashes = Wet, Reduced 15 amp charge rate
 - 4 Flashes = Wet, Standard 25 amp charge rate
- Yellow Light
 - 2 Flashes = GEL EXIDE® type, Reduced 15 amp charge rate
 - 4 Flashes = GEL EXIDE® type, Standard 25 amp charge rate
- Green Light
 - 2 Flashes = GEL-AGM, Reduced 15 amp charge rate
 - 4 Flashes = GEL-AGM, Standard 25 amp charge rate

CHANGING BATTERY TYPE SETTING

While holding down the buttons shown below, turn the key switch on.

Wait until one of the battery indicator LEDs flashes the current setting, then release the switches.

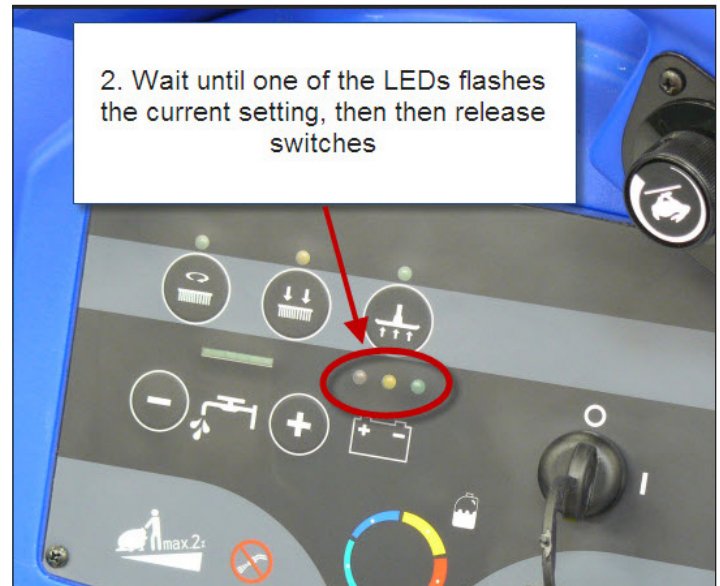
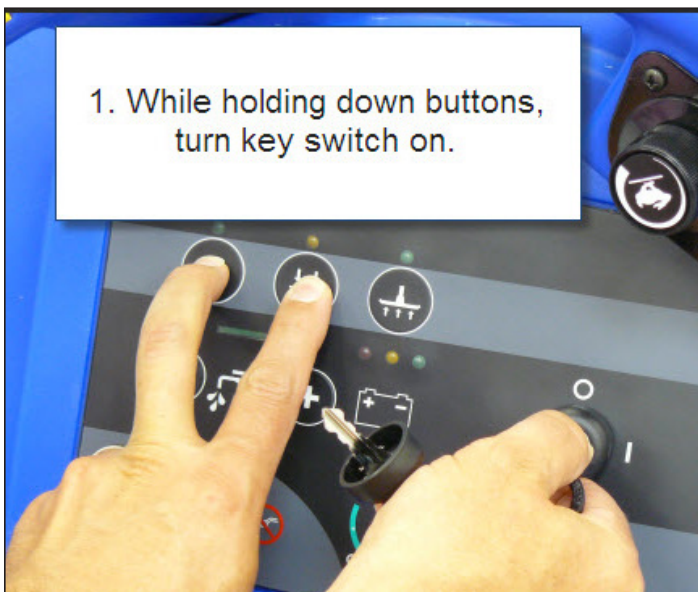

Within 3 seconds toggle the button shown below to advance the green bar LED to the desired setting.



Green bar setting

- 1st green bar - WET @ 25 amps, 250 & 330 ah batteries (4 RED blinks).
- 2nd green bar - GEL/AGM @ 25 amps, 260 & 312 AGM (4 GREEN blinks).
- 3rd green bar - GEL EXIDE @ 25 amps (4 YELLOW blinks).
- 4th green bar - WET @ 15 amps (2 RED blinks).
- 5th green bar - GEL/AGM @ 15 amps (2 GREEN blinks).
- 6th green bar - GEL EXIDE @ 15 amps (2 YELLOW blinks).

NOTE: When using batteries with a capacity less than 160Ah@5h, use the REDUCED charging current with setting 4, 5 or 6, according to the type of batteries installed to avoid battery overheating during charging.

Wait for the battery indicator LED to flash out confirmation of the new setting, then turn the key switch off.



TROUBLESHOOTING

INSUFFICIENT MACHINE OPERATION TIME

Possible Causes:

- Batteries not fully charged
 - If there is any question whether the batteries are fully charged, they should be charged for at least 16 hours.
- One or more weak batteries
 - To determine if one of the batteries is weak, measure the voltage across each individual battery while operating the machine. Write down the values and compare them. A battery that has a dead cell will typically be 1 – 2 volts lower than the others.
 - Use a battery load tester to test each battery.
 - For wet batteries, a hydrometer can be used to check the specific gravity of the electrolyte in each cell. A dead cell is one that reads 50 points or more lower than the other cells.
- Battery Cable Connections

THE BATTERY CHARGER DOES NOT CHARGE

Possible Causes:

- Battery Charger
- Connections
- Batteries

Note: The battery charger will charge, even if it cannot communicate with the main machine controller.

REMOVAL AND INSTALLATION

BATTERIES

If the batteries are more than a year old, it is usually best to replace the entire set of batteries, rather than just one battery.



WARNING!

Use extreme caution when working with batteries. Sulfuric acid in batteries can cause severe injury if allowed to contact the skin or eyes. Explosive hydrogen gas is vented from the batteries through openings in the battery caps. This gas can be ignited by any electrical arc, spark or flame. Do not install any lead-acid battery in a sealed container or enclosure. Hydrogen gas from overcharging must be allowed to escape.

When Servicing Batteries

- Remove all jewelry
- Do not smoke
- Wear safety glasses, rubber gloves and a rubber apron
- Work in a well-ventilated area
- Do not allow tools to touch more than one battery terminal at a time
- ALWAYS disconnect the negative (ground) cable first when replacing batteries to prevent sparks.
- ALWAYS connect the negative cable last when installing batteries.



CAUTION!

Electrical components in this machine can be severely damaged if the batteries are not installed and connected properly. Nilfisk-Advance, a qualified electrician, or the battery manufacturer should install batteries.

1. Empty the recovery tank and tip it up.
2. Turn key switch off.
3. Remove the battery cables.
 - a. Do not allow metal tools to connect between battery cables or posts.
 - b. Prevent cable ends from touching other cable ends or posts.
4. Remove battery.
5. Install battery.

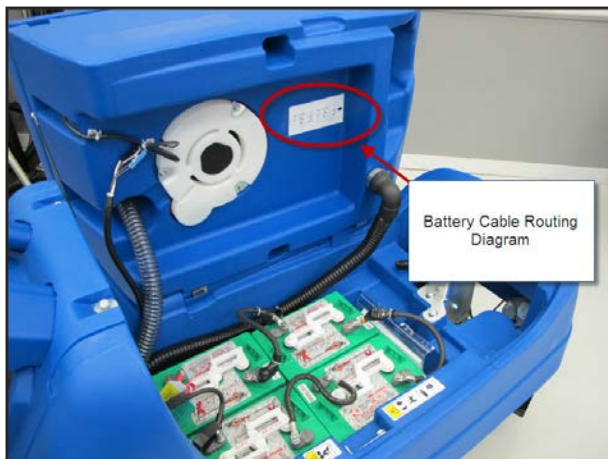

are connected properly. Refer to decal under the recovery tank.

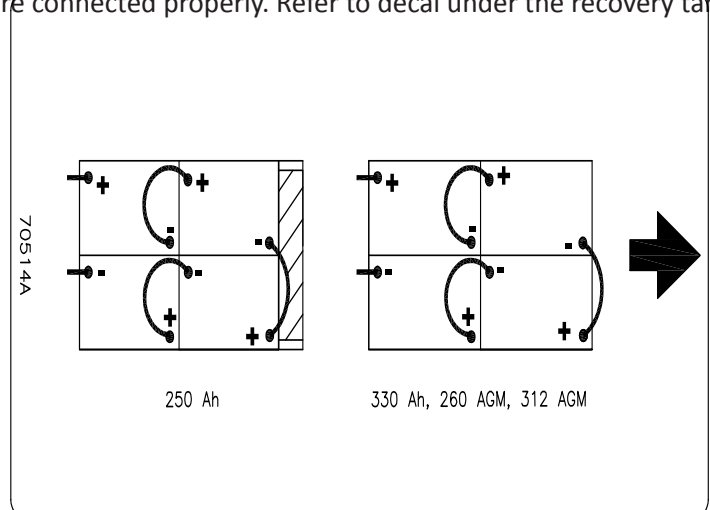

BATTERY CHARGER

The battery charger is mounted to the bottom of the frame with 4 bolts that are screwed into threaded holes. Photos and procedures are for the S.P.E. charger. Delta-Q charger procedure is similar.

1. Cut tie straps securing AC power cable.

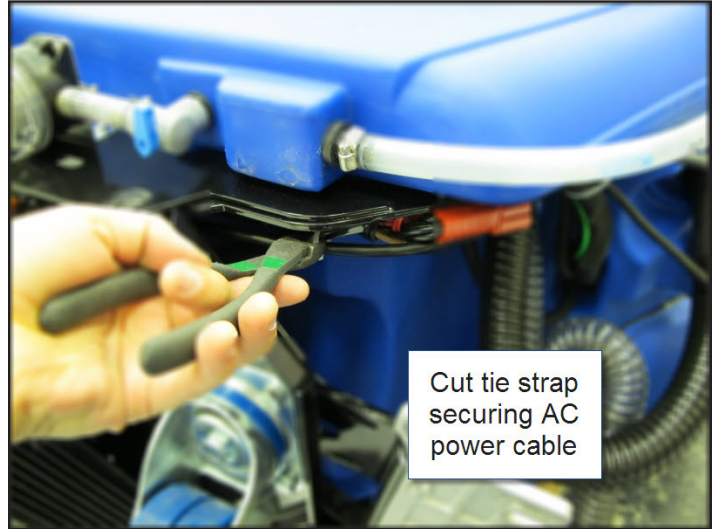
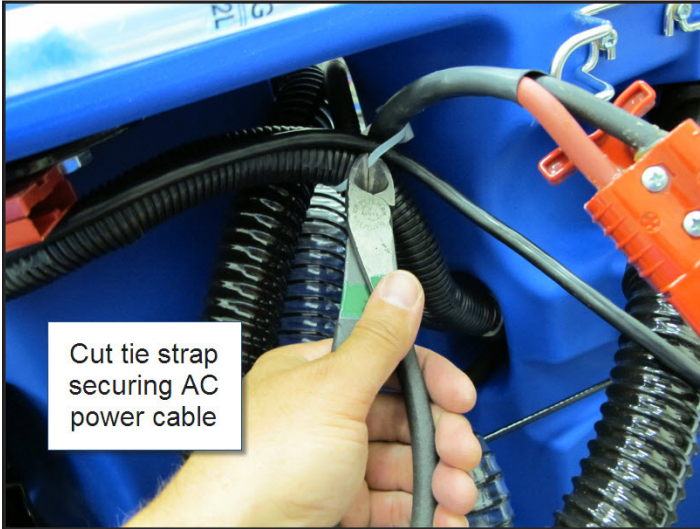

2. Cut tie straps securing electrical connectors.

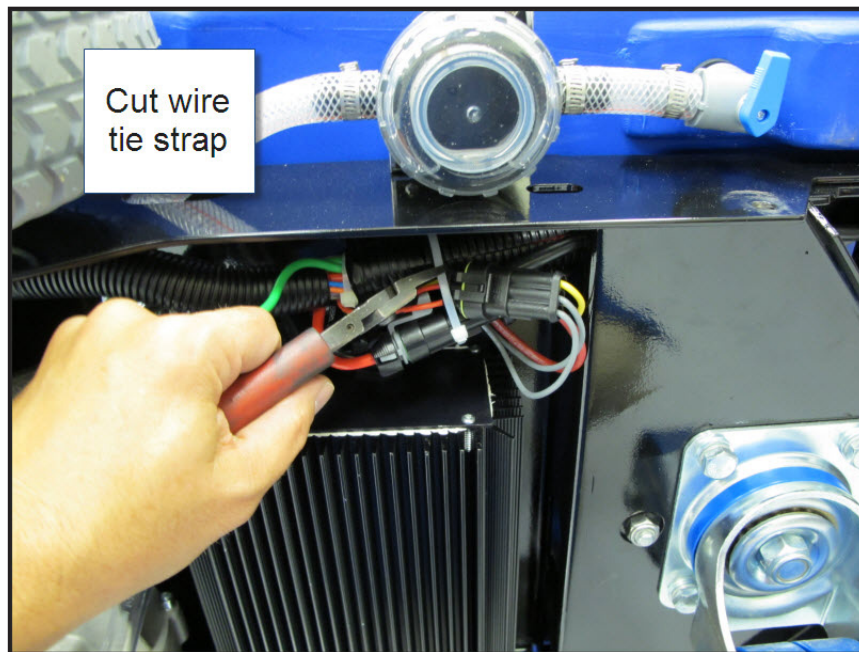

3. Disconnect electrical connectors.

4. Remove 4 battery charger mounting bolts.

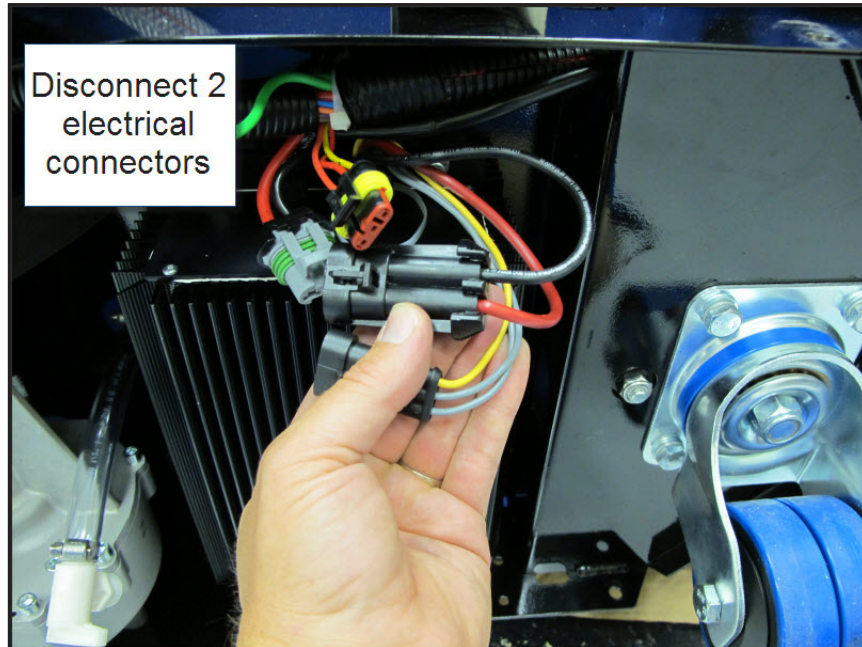

5. Remove charger, thread AC power cable through opening.

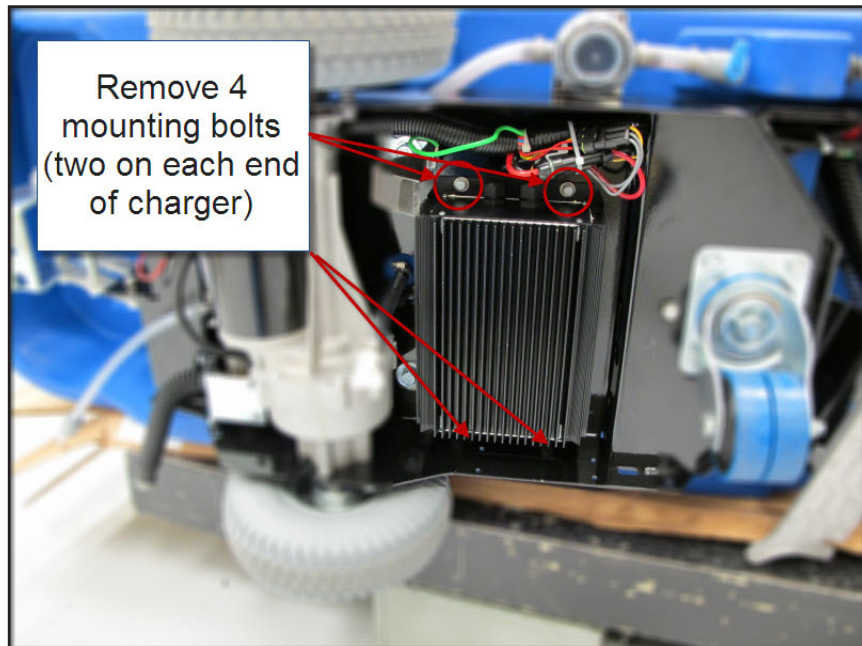

6. Reassemble in reverse order. Tie wiring in same locations using new tie straps.
7. When installing a new Delta-Q charger, you must select the correct charging profile for the type of batteries installed in the machine. See the Delta-Q IC650 Product Manual (710-0138-Delta-Q.pdf) for complete instructions on selecting the profile. See the Delta-Q IC650 Battery Charging Profiles Table in this chapter for selecting the correct profile.

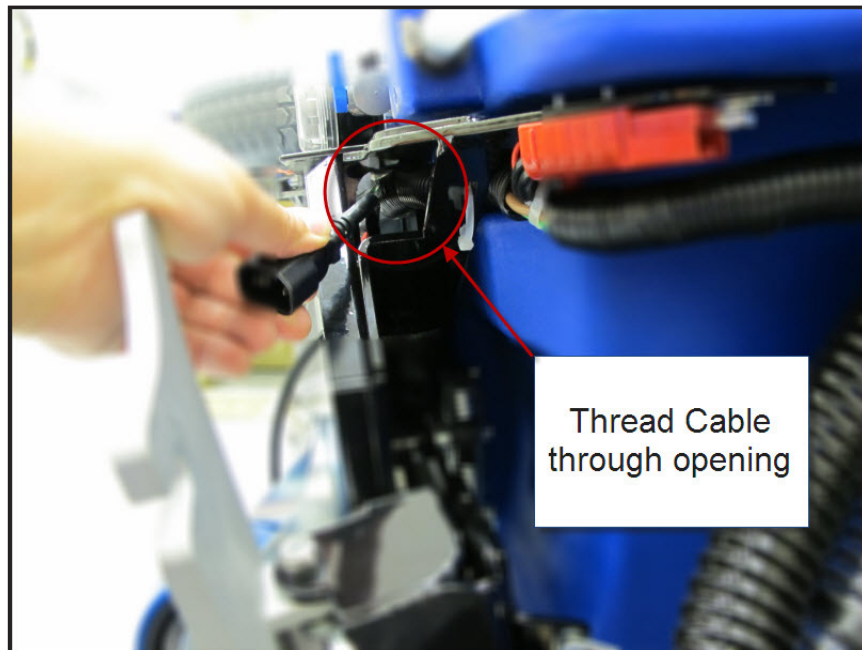

SPECIFICATIONS

LOW VOLTAGE CUT-OUT THRESHOLD VOLTAGES

	INDICATION	TRANSITION THRESHOLD (VOLT)		CONSEQUENCE
		WET	GEL	
1	GREEN LED: fixed - YELLOW LED: fixed	22 V	22.2 V	
2	YELLOW LED: fixed - RED LED: flashing	20.4 V	21.6 V	Brushes OFF
3	RED LED: flashing -Safety threshold	19.4 V	20.6 V	Vacuum system OFF
4	RED LED: flashing Drive threshold	18.0 V	18.0V	Drive system OFF

Battery Run Time

The following table provides a reference point for approximate battery run times.

US SOLD MACHINES

P/N	DESCRIPTION	WEIGHT LB W/ SOL FULL & 312 AGM	AMP (A)	P/N 40136A 242 Ah Wet Run Time (hr)	P/N 40953A 260 Ah AGM Run Time (hr)	P/N 891384 310 Ah Wet Run Time (hr)	P/N 40964A 312 Ah AGM Run Time (hr)
05370A	FOCUS II BOOST28	970	45	2.6 - 3.9		3.7 - 5.5	
05380A	FOCUS II BOOST32	1000	45				
05390A	FOCUS II DISC26	975	60				
05400A	FOCUS II DISC28	980	60				
05420A	FOCUS II CYL28	970	60				
05410A	FOCUS II DISC34	970	65				

WIRING DIAGRAM - 05370T-E REV F Sheet 1 of 2

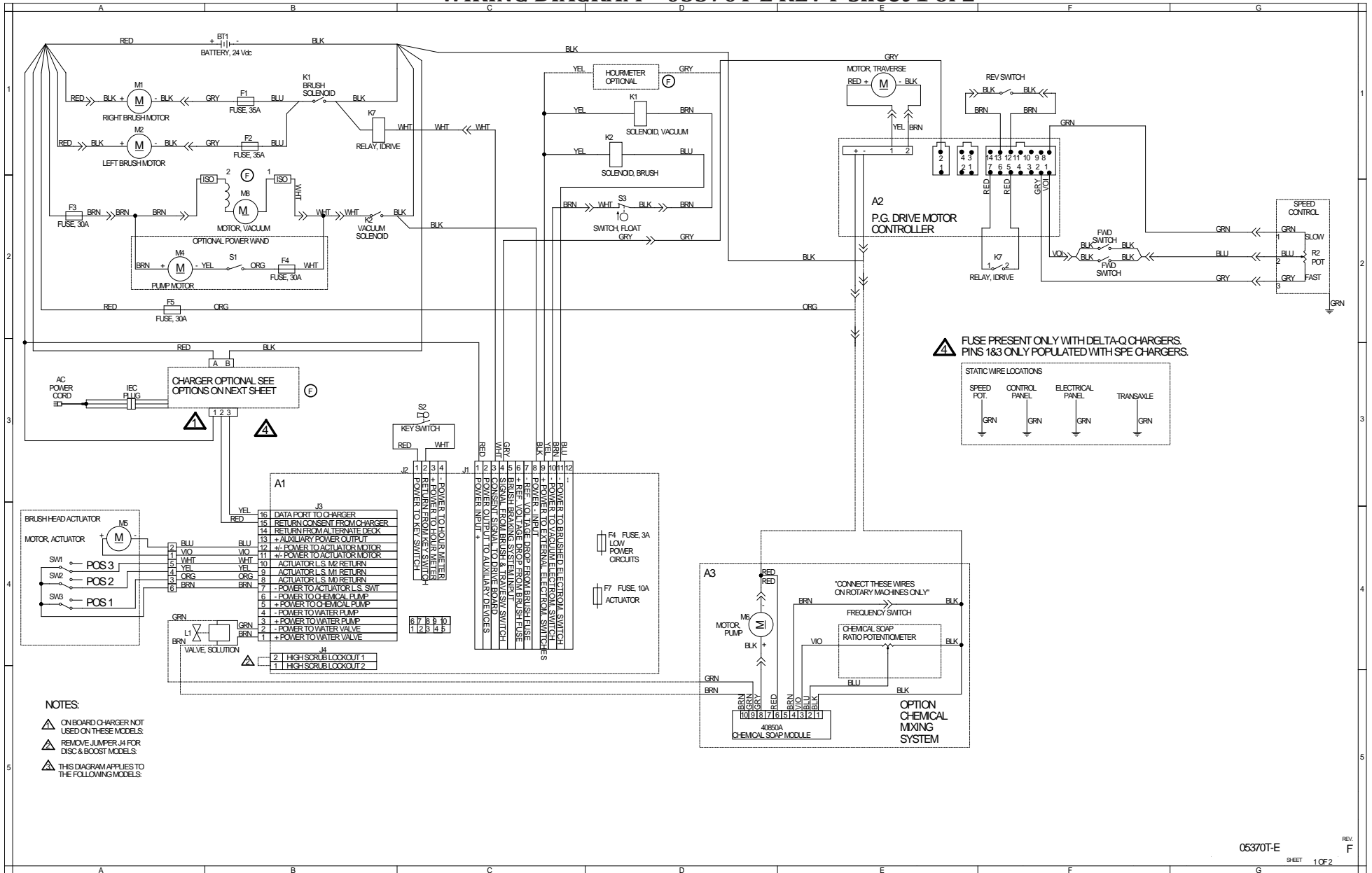

WIRING DIAGRAM - 05370T-E REV F Sheet 2 of 2

⚠ ON BOARD CHARGER NOT USED ON THESE MODELS:

FOCUS II DISC 34	56300669
FOCUS II DISC 26	56300668
FOCUS II DISC 26	56300667
FOCUS II BOOST 26	56300661

MODEL PART NO.

⚠ REMOVE JUMPER J4 FOR DISC & BOOST MODELS:

FOCUS II DISC 34 CHEM	05410C
FOCUS II DISC 26 CHEM	05400C
FOCUS II DISC 26 CHEM	05390C
FOCUS II BOOST 32 CHEM	05380C
FOCUS II BOOST 26 CHEM	05370C
FOCUS II DISC 34	05410A
FOCUS II DISC 26	05400A
FOCUS II DISC 26	05390A
FOCUS II BOOST 32	05380A
FOCUS II BOOST 26	05370A
SCRUBTEC 886	05410E
SCRUBTEC 871	05400E
SCRUBTEC 866	05390E
SCRUBTEC BOOST 8	05370E

MODEL PART NO.

⚠ THIS DIAGRAM APPLIES TO THE FOLLOWING MODELS:

SCRUBTEC 871C	05420E
SCRUBTEC 886	05410E
SCRUBTEC 871	05400E
SCRUBTEC 866	05390E
SCRUBTEC BOOST 8	05370E
FOCUS II CYL 26 CHEM	05420C
FOCUS II DISC 34 CHEM	05410C
FOCUS II DISC 26 CHEM	05400C
FOCUS II DISC 26 CHEM	05390C
FOCUS II BOOST 32 CHEM	05380C
FOCUS II BOOST 26 CHEM	05370C
FOCUS II CYL 26	05420A
FOCUS II DISC 34	05410A
FOCUS II DISC 26	05400A
FOCUS II DISC 26	05390A
FOCUS II BOOST 32	05380A
FOCUS II BOOST 26	05370A

MODEL PART NO.

CHARGER CONNECTIONS (OPTIONAL) (F)

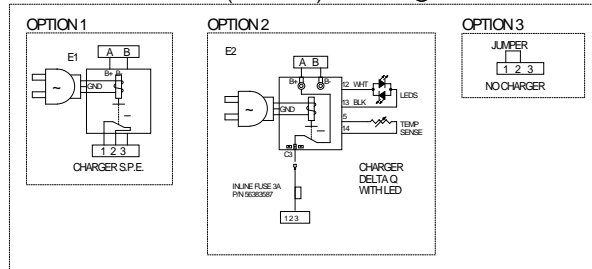

PENNY & GILES CONTROL CONNECTIONS

PIN	DESCRIPTION
1	THROTTLE WIPER
2	THROTTLE HIGH
3	AUX 2 OUT
4	SLOW/FAST SW/T
5	FAST SW
6	INHIBIT 1 PROGRAM TO INHIBIT TRAV AND PAD WHEN TILT SWITCH IS CLOSED
7	FUSED 36V OUT
8	THROTTLE LOW
9	BELLY SW/T
10	STATUS IND
11	AUX 3 OUT
12	REV SW/T
13	OV/CUT
14	INHIBIT 2 CHARGER

FUNCTION BOARD CONNECTION J1 CONNECTIONS

PIN	DESCRIPTION	IN/OUT	V/NF	MAX. AMP	BAT	CONNECTED TO
1	POWER INPUT +	IN	24V	10	--	--
2	POWER OUTPUT TO AUXILIARY DEVICES	OUT	24V	<1	--	--
3	ONSENT SIGNAL TO DRIVE	OUT	24V	<1	--	DRIVE KEY RELAY COIL
4	SIGNAL FROM DRIVE TO START BRUSH	IN	0V	<1	--	TRAVERSE SELECTED = 0V
5	BRUSH BRAKING SYSTEM INPUT	IN	--	100 IMP.	--	--
6	+REF. VOLTAGE DROP FROM BRUSH FUSE	IN	0V	<1	--	--
7	-REF. VOLTAGE DROP FROM BRUSH FUSE	IN	0V	<1	--	--
8	POWER INPUT -	IN	0V	10	--	--
9	+ POWER TO EXTERNAL SOLENOID COILS	OUT	--	1	--	--
10	- POWER TO EXTERNAL SOLENOID COILS	OUT	0V	1	--	--
11	+ POWER TO EXTERNAL SOLENOID COILS	OUT	0V	A	--	VAC & BRUSH SOLENOID COIL
12	--	--	--	--	--	--

CONNECTION DIAGRAM 05370T-W REV C

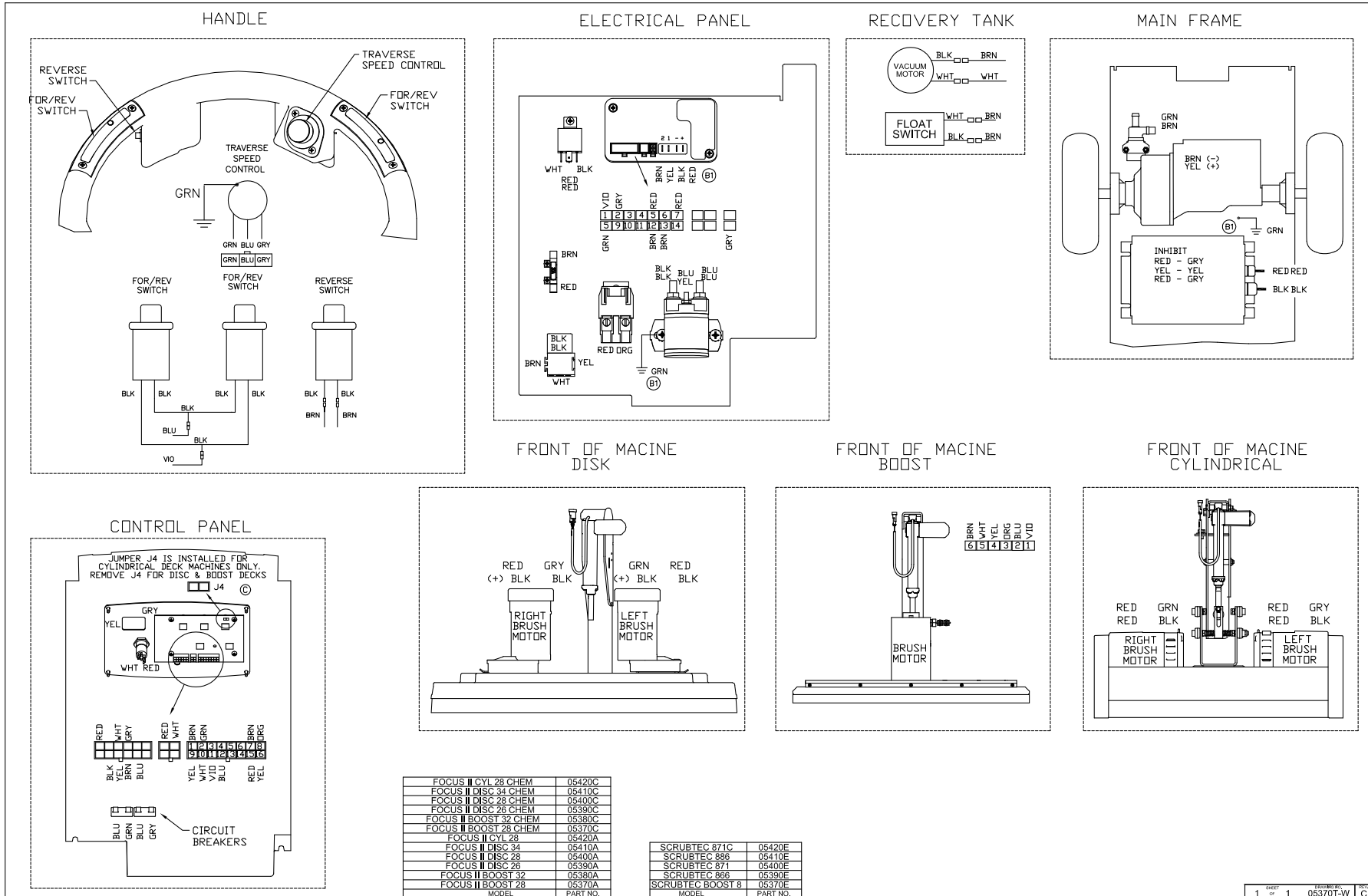

OPTIONS AND ACCESSORIES

POWER WAND

An optional power wand provides pressurized spray and vacuum for spot cleaning. It consists of a telescoping wand, vacuum hose, solution hose, electric pump, switch and some additional plumbing and wiring. If the machine is equipped with the chemical mixing system there is additional plumbing to tap into the chemical hose. When not in use, the wand hangs on the side of the machine and the hose hangs on the back. To use the wand, the operator removes the squeegee vacuum hose and connects it to the wand hose. The wand solution hose is connected to a quick connect fitting which is installed at the back of the machine.

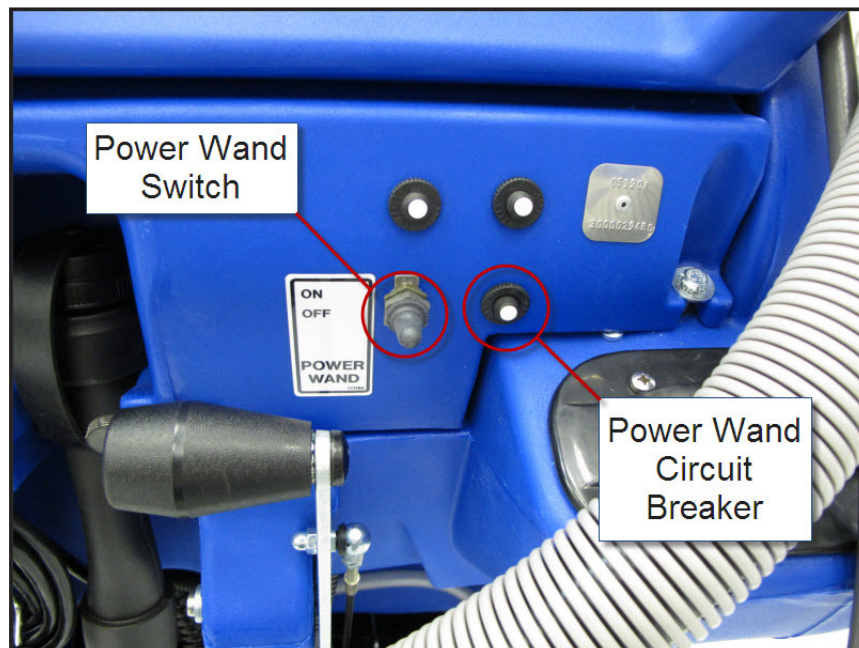
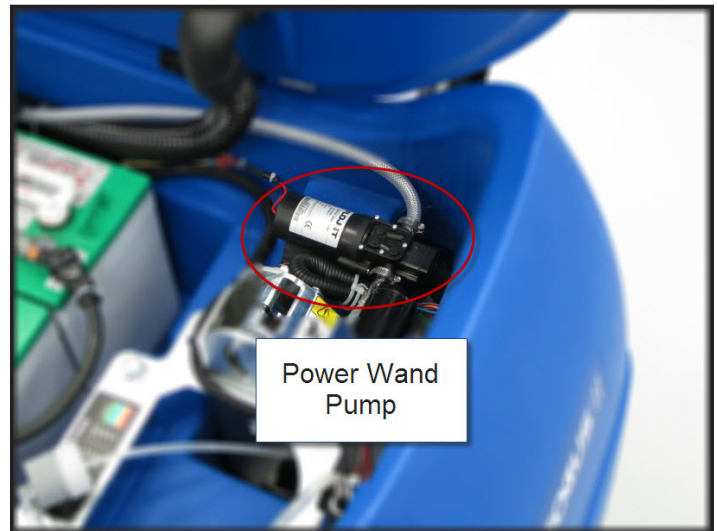

Plumbing - Power Wand with EcoFlex

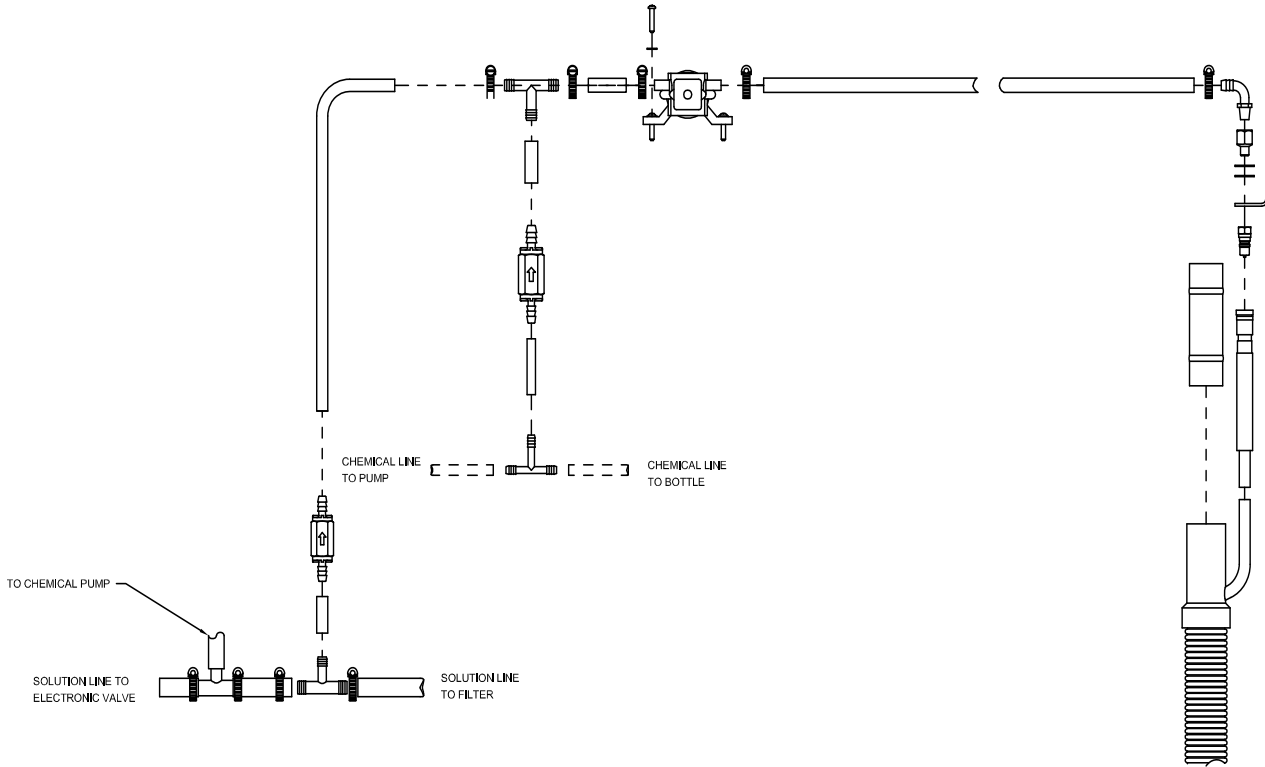

Plumbing - Power Wand Without EcoFlex

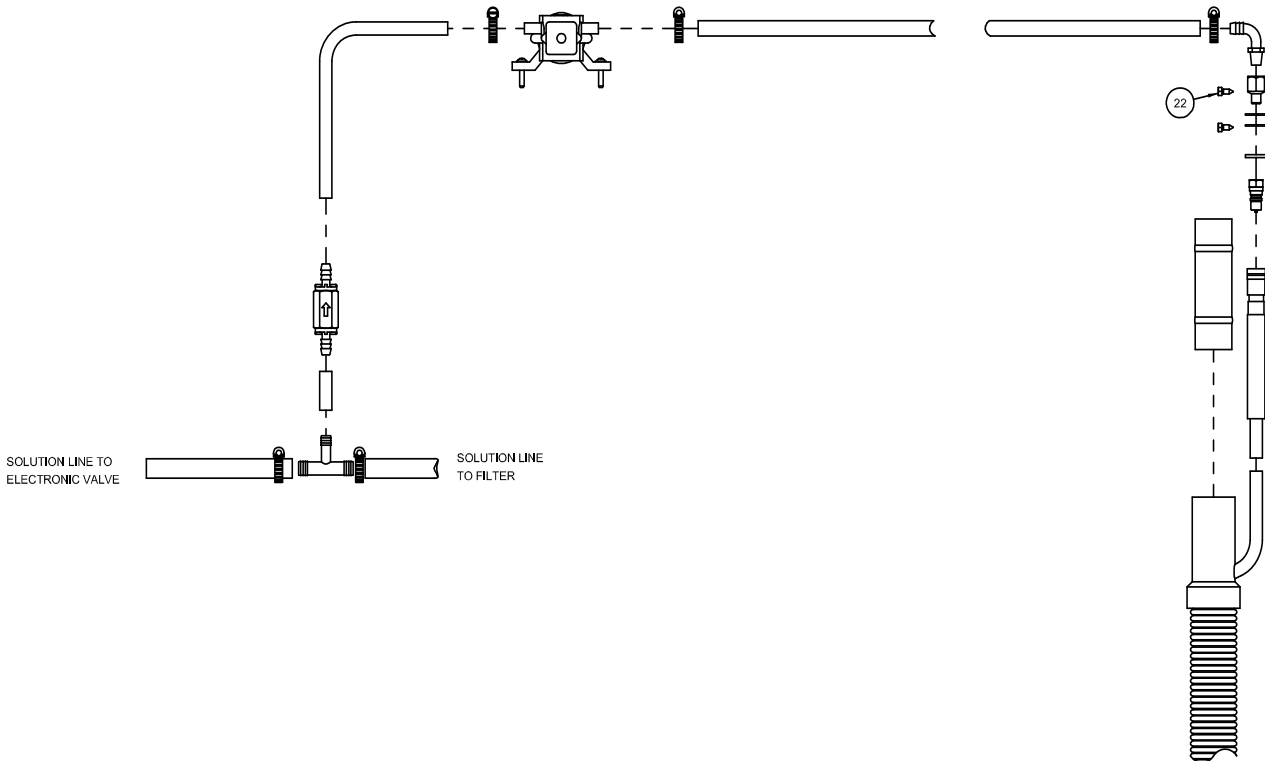

HOUR METER

An optional hour meter can be mounted to the machine control panel. It tracks the time that the machine is moving either forward or reverse.



PARKING BRAKE KIT

The optional parking brake kit has a manually operated lever that presses a plunger against a drive wheel to act as a brake.



CLARKE BATTERY MAINTENANCE SYSTEM

The Clarke battery maintenance system is a special module that pulses a DC current into the batteries to prolong their life. It is powered by the battery pack. There are no serviceable parts.



RECOVERY SYSTEM

FUNCTIONAL DESCRIPTION

The job of the recovery system is to remove the dirty water from the floor and store it in the recovery tank. The dirty water is then disposed of. Dirt and water are lifted off the floor into the recovery tank by airflow, created by a vacuum motor. The wastewater and air enter the vacuum system at the squeegee tool, through notches in the front squeegee blade. The air and wastewater move through the squeegee vacuum hose at high speed until it reaches the recovery tank. The heavier water falls to the bottom of the recovery tank. The airflow continues through the vacuum fan inlet port, vacuum motor and exhaust port. A debris basket inside the recovery tanks helps to redirect the water downward and catches large particles. No wastewater ever actually moves through the vacuum motor, just the working air. A float switch in the recovery tank prevents the tank from being overfilled and stops any water from being sucked into the vacuum motor. The squeegee is raised and lowered manually using the squeegee lift lever. Springs apply downward pressure on the squeegee.

Here is how the vacuum motor circuit works. The controller supplies 24v out to the relay coil terminal 85 when the key switch is on. The other side of the relay coil (terminal 86) is connected to a switch inside the controller. To energize the relay, the controller closes the switch which completes the path to B-. The vacuum motor is supplied constant B+ voltage through a fuse. When the relay is at rest the motor does not run because there is not a complete circuit to B-. When the relay is energized it connects terminals 30 and 87 together providing a path to B- for the vacuum motor causing it to turn on.

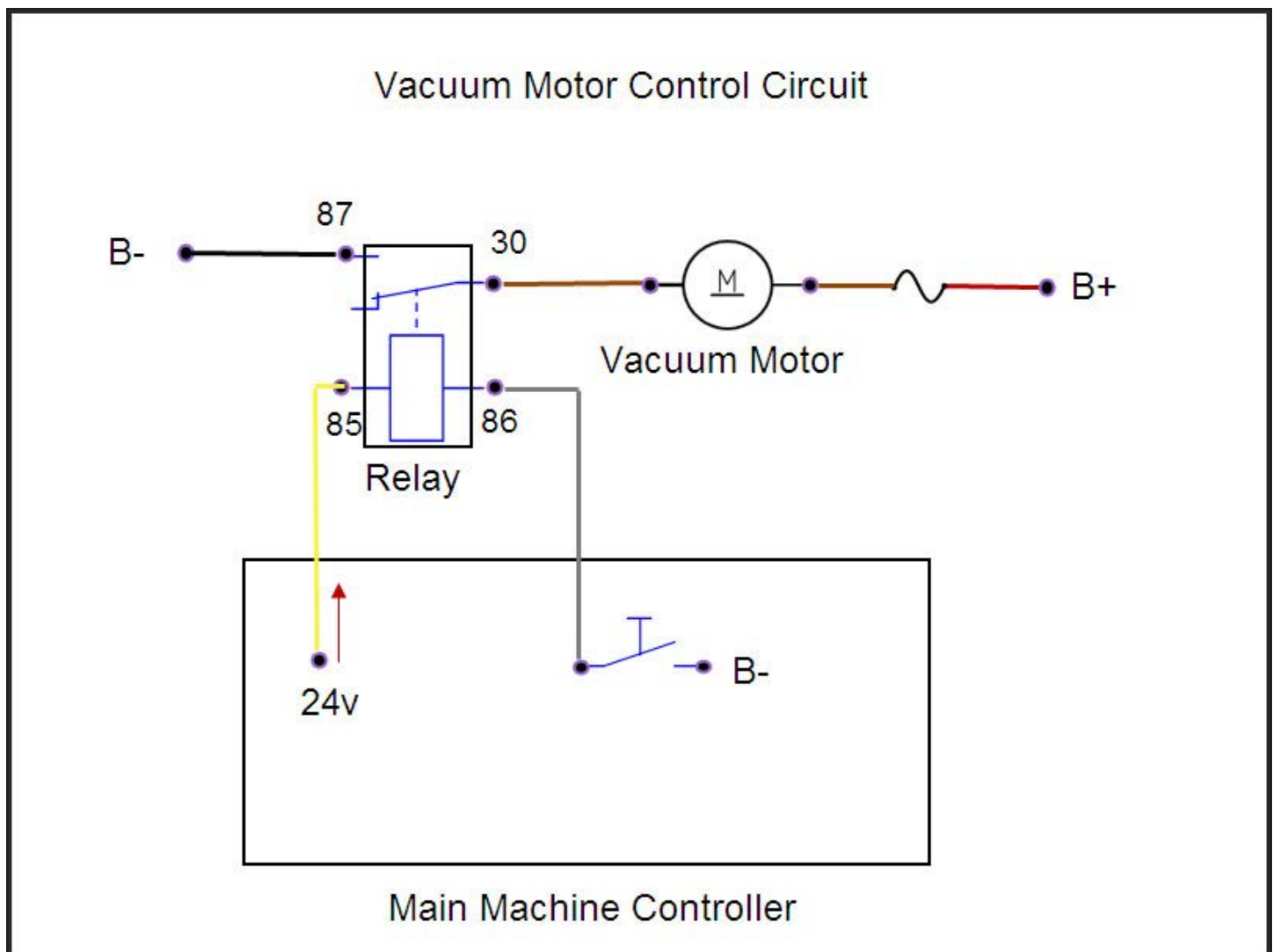

The vacuum solenoid (relay) is turned on when the following inputs are met:

- Self test is completed
- Operator request
 - o One Touch Control Button has been pressed or
 - o Vacuum Motor Button has been pressed

The vacuum solenoid is de-energized when the operator turns off the scrub system following a timed delay.

COMPONENT LOCATIONS

- Recovery Tank
- Recovery Tank Lid
- Gasket, Recovery Tank
- Recovery Tank Drain Hose
- Squeegee Vacuum Hose
- Vacuum Motor
- Vacuum Motor Suction Port
- Debris Basket
- Float Switch

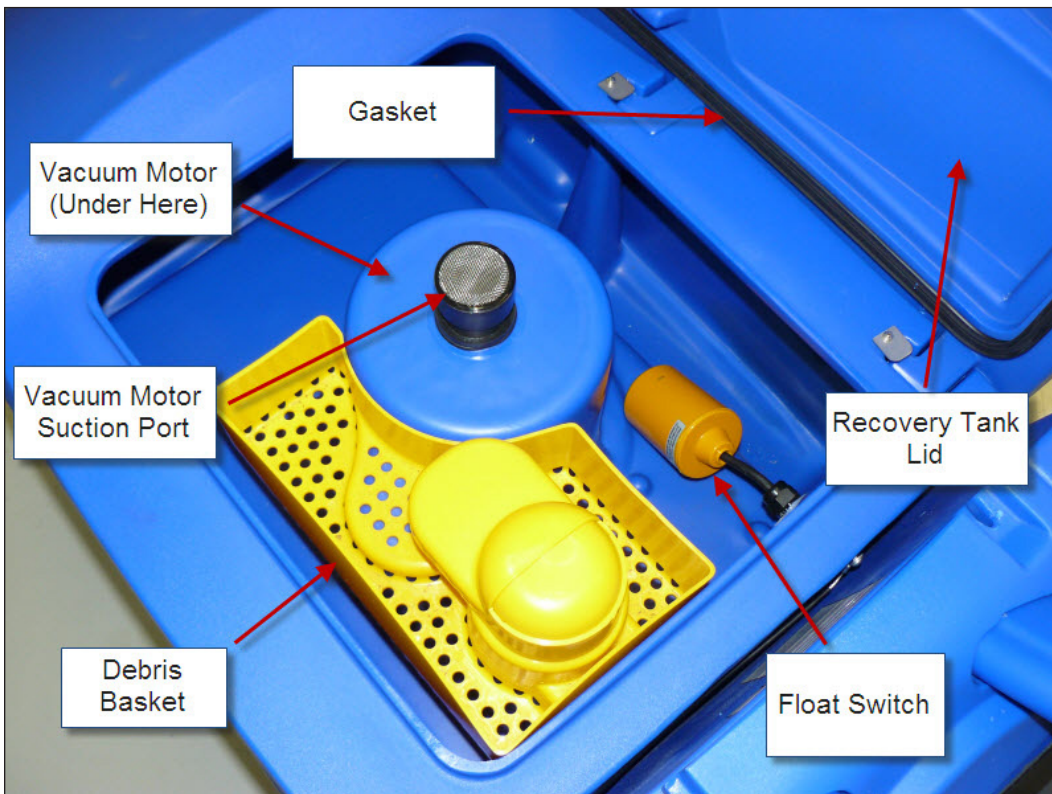
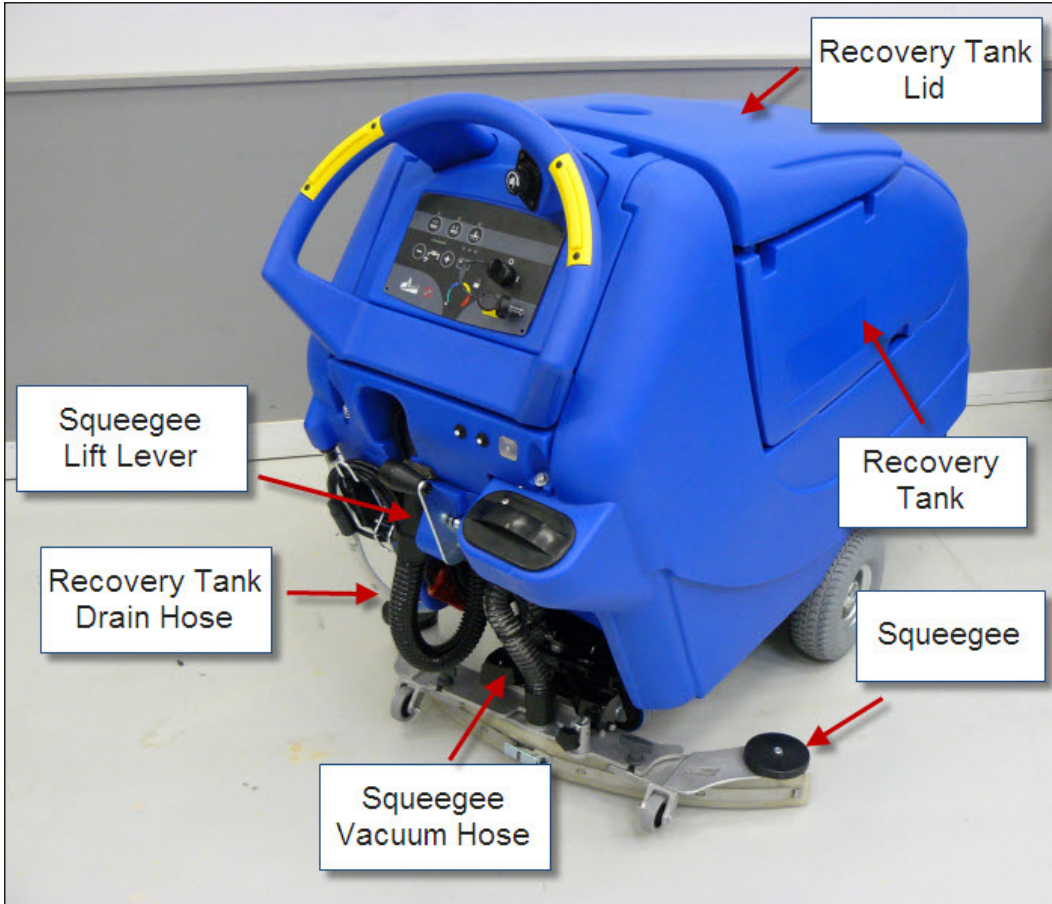

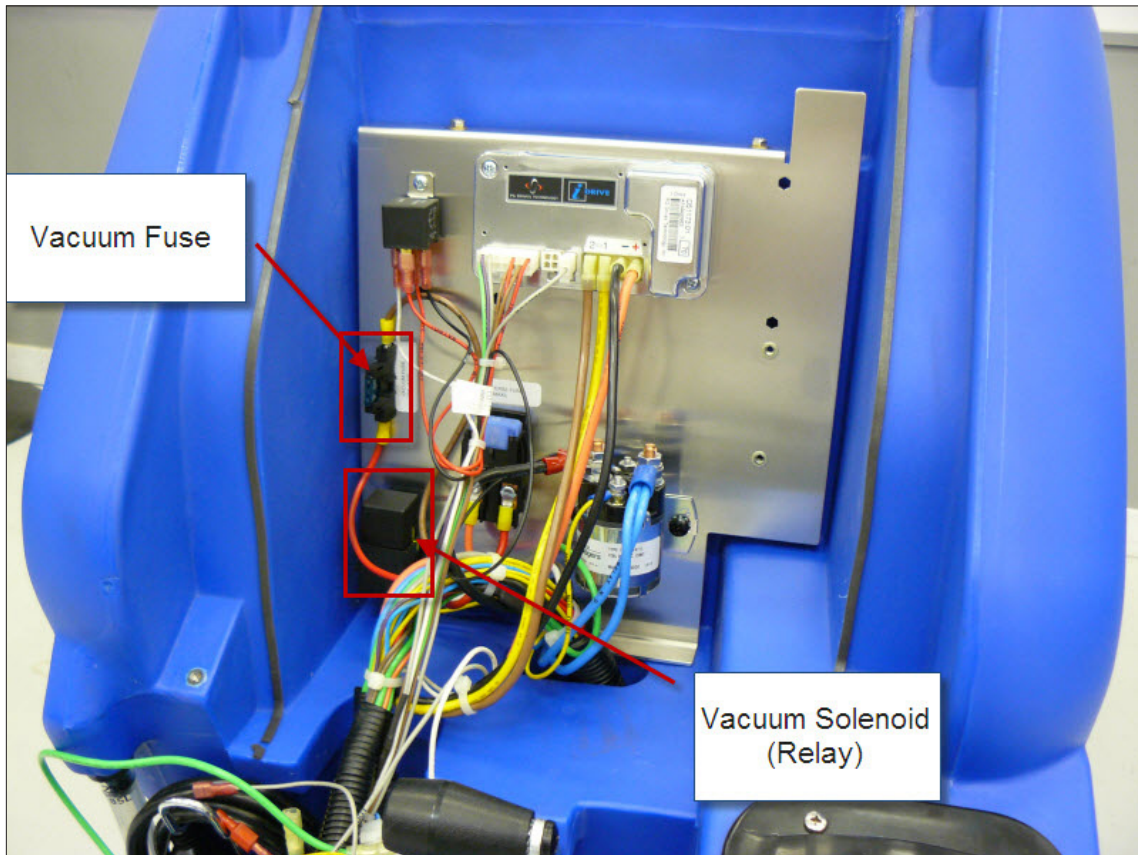
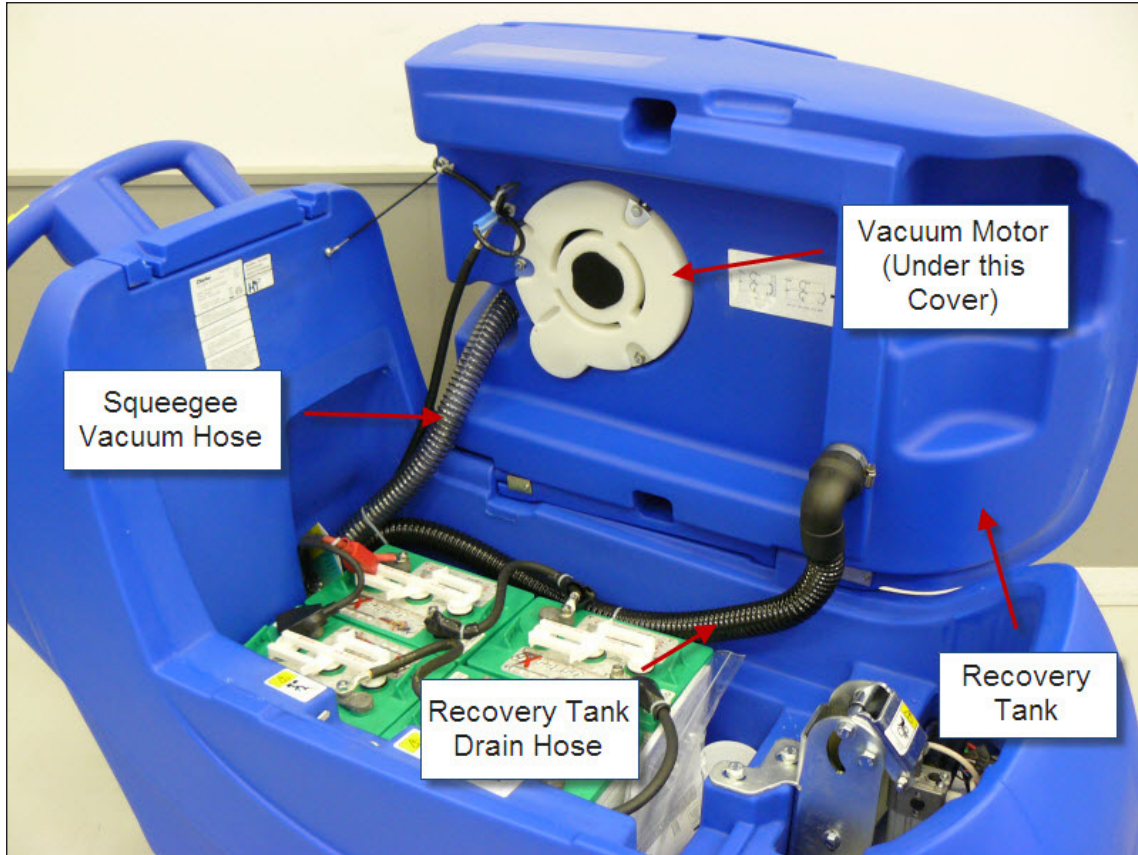

TROUBLESHOOTING

VACUUM MOTOR DOES NOT TURN ON (SCRUB FUNCTION WORKS)

Possible Causes:

- Blown (Open) Fuse
- Open Float Switch
- Defective Vacuum Motor
- Defective Vacuum Motor Solenoid (Relay)
- Defective Wiring
- Defective Main Machine Controller

INSUFFICIENT WATER PICK UP

Possible Causes:

- Restricted air flow
 - o Clogged or kinked squeegee vacuum hose
 - o Clogged vacuum motor inlet or outlet port
- Damaged Squeegees
- Air leaks
 - o Recover Tank Lid Gasket is not sealing
 - o Cracked Squeegee Vacuum Hose
 - o Cracked Recovery Tank
- Vacuum motor is weak

VACUUM MOTOR DOES NOT SHUT OFF WHEN RECOVERY TANK IS FULL

Possible Causes:

- Float Switch is stuck closed

REMOVAL AND INSTALLATION

VACUUM MOTOR

1. Turn off key switch, drain recovery tank and lift recovery tank up.
2. Cut tie straps securing wiring and connector.
3. Disconnect vacuum motor electrical connection.
4. Remove vacuum motor cover mounting screws and cover.

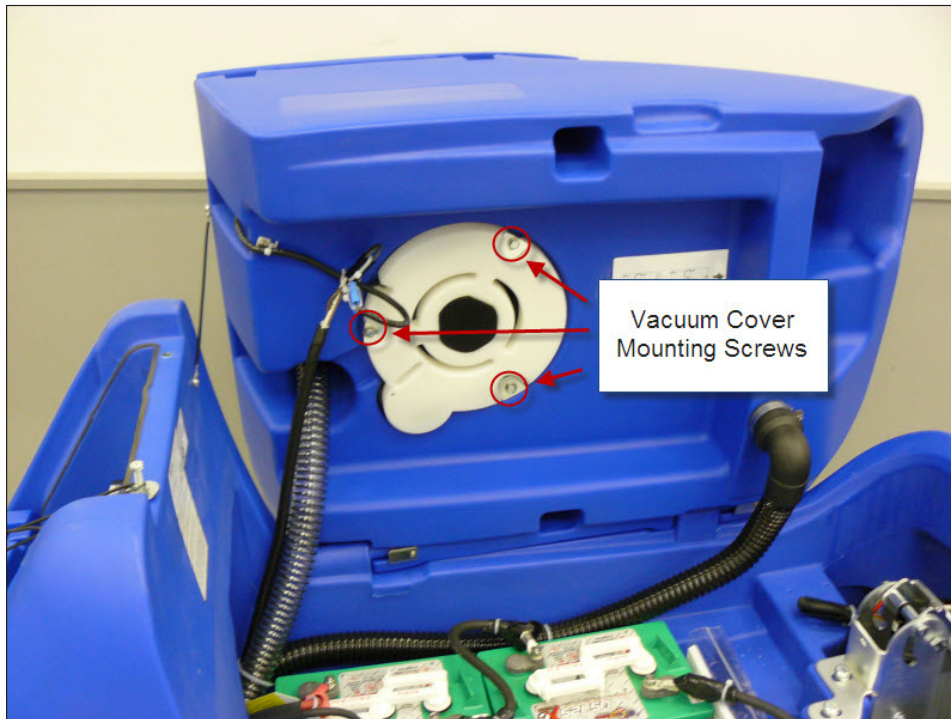

5. Remove vacuum motor and foam pieces.



6. Reassemble in reverse order taking care to position all foam pieces correctly and secure wiring with new tie straps. Route vacuum motor wiring lead in slot of vacuum motor cover.

SPECIFICATIONS

VACUUM WATER LIFT:

- Blocked off - measured at squeegee hose end 55 " H2O
- With 1 inch hole measured approx 10" H2O

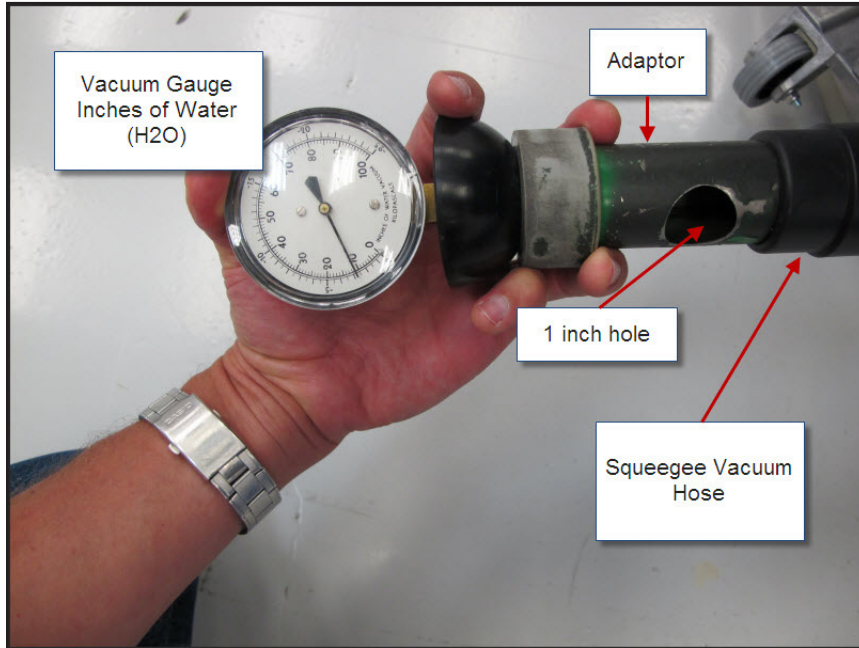

VACUUM MOTOR AMP DRAW

With everything assembled and squeegee off the floor - 21 Amps

VACUUM FAN AIR FLOW MOVEMENT

Maximum Flow – 1.5 cubic feet/second (29.6 liters/second)

SPECIAL TOOLS

- Water Lift Gauge, part number 56205281
- 1 inch open hole adaptor – This can be fabricated from a short section of PVC pipe.

SCRUB SYSTEM, CYLINDRICAL

FUNCTIONAL DESCRIPTION

The disc scrub system moves the scrub head up and down and turns the scrub motors on and off at the operator's request to provide floor scrubbing action. The brushes spin toward the center at the bottom of each brush. The head is moved up and down by an electric actuator motor that has integrated position switches. The weight of the scrub head provides the downward pressure for scrubbing. Note: The extra scrub pressure button is disabled on models with a cylindrical brush head via a jumper on the main machine control board. See the section on removing and replacing the main control board for more information.

The main machine controller energizes the brush solenoid to turn on the brush motors when the following inputs have been met:

- Key switch on
- Operator request – One Touch Control Button pressed
- Machine moving signal is received from PG Drive Motor Controller
 - Approximately 17 volts received from the main controller (J1 Pin 4) is switched to battery negative by the Drive Motor Controller, dropping the voltage to 0 volts.

The main machine controller directly drives the brush head actuator. It applies system voltage across the two actuator motor wires to move the motor up. It reverses polarity to move the motor down. The brush head actuator also has 3 position switches built into it to let the main machine controller know how high or low the brush head is. Each switch receives a 5 volt feed through a resistor from the controller which returns back to battery negative on a common wire to connector J3 pin 7. The controller has "internal voltmeters" which monitors the signal voltage of each switch circuit. When the switch is closed, the voltage signal is nearly 0 volts. When the switch is open, the voltage is approximately 5 volts.

1. Full Up Position = M0 is 5v (M1 and M2 are both 0v)
2. Normal Scrub Position = M1 is 5v (M0 and M2 are both 0v)

When the key is turned on the main machine controller looks to see if the brush head is fully up by monitoring the M0 switch voltage. If it is not 5v, it drives the actuator to the full up position. When the operator presses the One Touch Control Button the controller drives the actuator down until it sees the M1 switch open (5v). When the operator pushes the One Touch Control Button again to turn the scrub function off, the controller drives the actuator motor up until it sees the M0 switch open again (5v).

Scrub System - Disc and Cylindrical

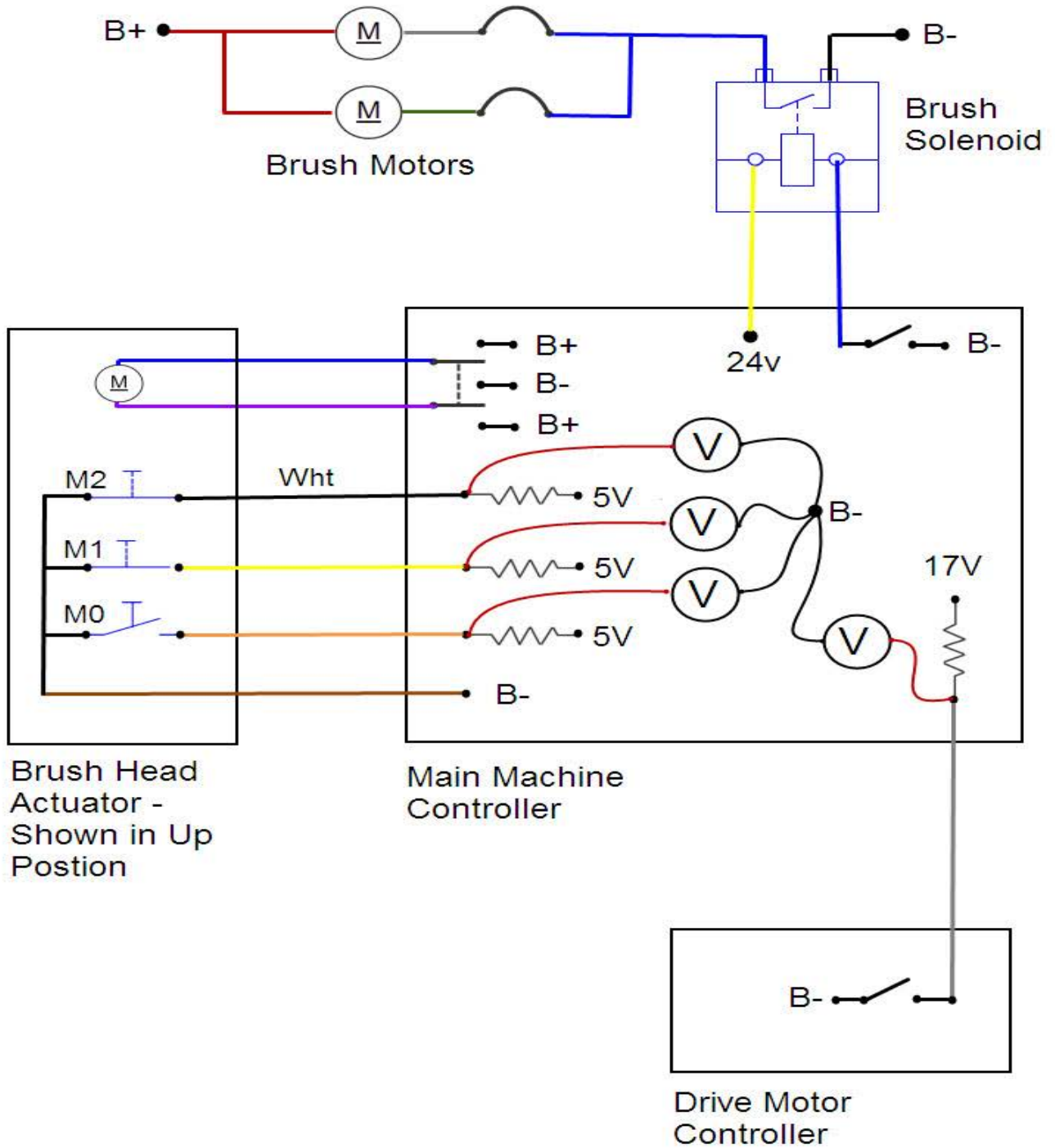

COMPONENT LOCATIONS

- Brush Drive Belts
- Brush Head Actuator
- Brush Solenoid
- Main Machine Controller

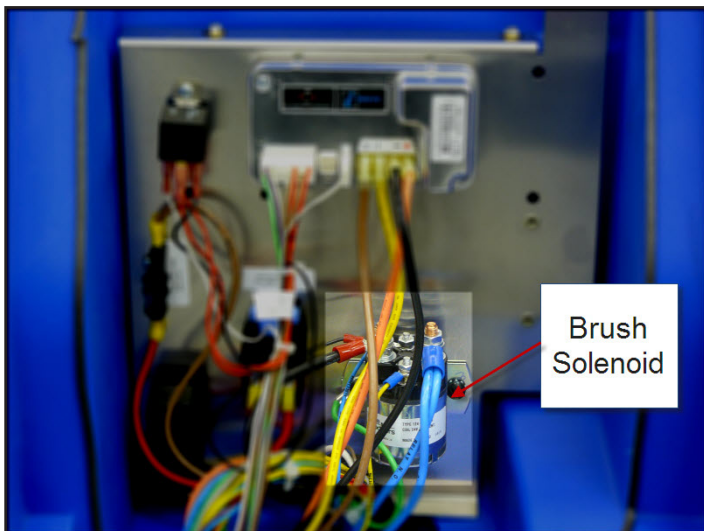
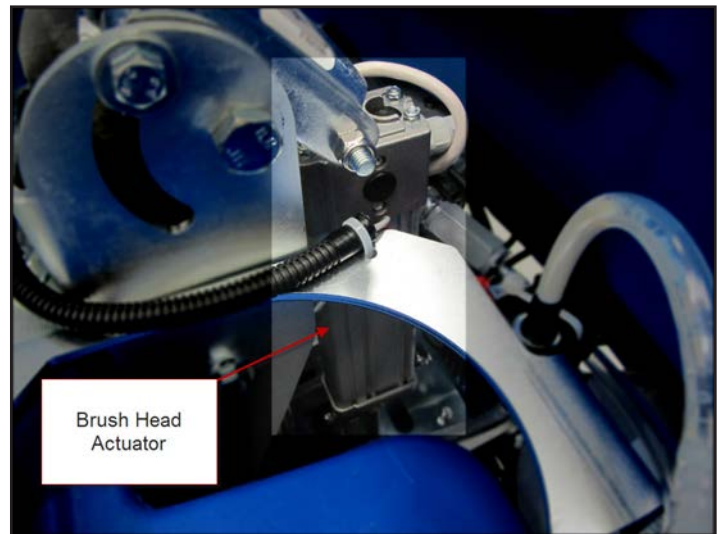
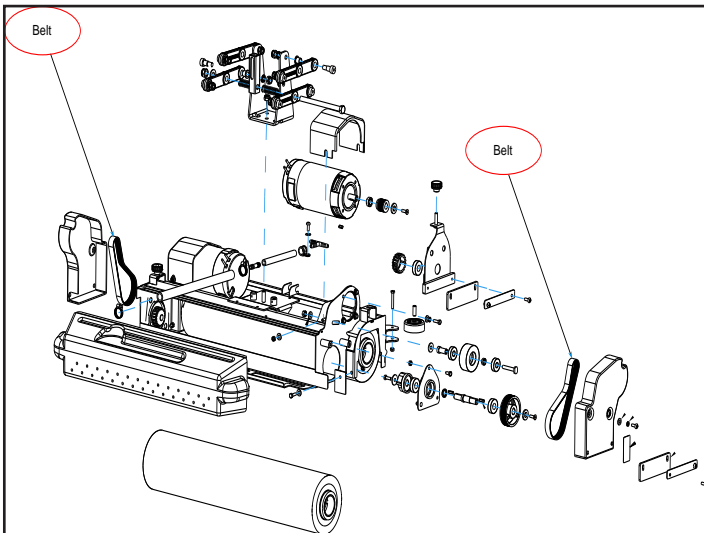

TROUBLESHOOTING

SCRUB MOTORS DO NOT TURN ON

Possible Causes

- Brush Solenoid (Contactor)
 - Open or shorted winding
 - Burned Contacts
- Wiring
- Main Machine Controller – Not energizing the brush solenoid.
- Drive Motor Controller – Not providing “machine moving signal”

SCRUB DECK WILL NOT RAISE OR LOWER

Possible Causes

- Brush Head Actuator - Check to make sure that no more than one position switch is open at a time. Unplug actuator and momentarily supply fused 24v power and ground to the two motor terminals to see if the motor will operate.
- Main Machine Controller
- Wiring

REMOVAL AND INSTALLATION

BRUSH DRIVE BELT

1. Remove Belt Cover
2. Loosen the idler pulley center mounting bolt
3. Remove drive belt
4. Install new drive belt
5. Apply force to push idler pulley against the back side of the belt
6. Tighten the idler pulley center mounting bolt
7. Check the belt tension. The belt should deflect about .020 inches (5 mm) with a force of about 22 lbs (10 kg). Readjust as required.

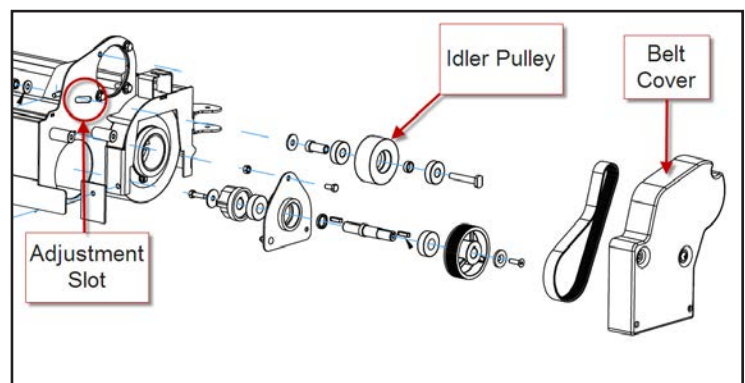

BRUSH HEAD ACTUATOR

1. Empty recovery tank.
2. Press the one touch control button to lower the brush head.
 - a. If the actuator does not move, slightly raise the brush head with a jack to take tension off of the mounting hardware
3. Turn key switch off.
4. Lift recovery tank up.
5. Disconnect electrical fastener.
6. Remove lower fastener.

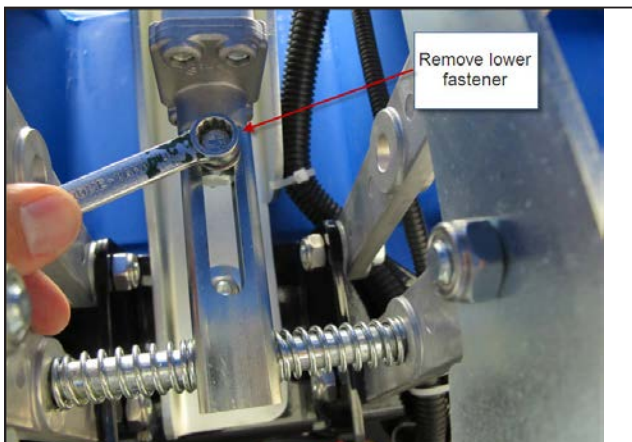

7. Remove upper fastener.



8. Remove actuator.
9. Reassemble in reverse order.

SPECIFICATIONS

BRUSH HEAD ACTUATOR AMP DRAW

Upward with weight of deck - ~ 2-3 Amps

BRUSH CONTACTOR

Winding Resistance – 53 ohms

GAS SPRING

Force – 112 pounds (500 N)

SCRUB SYSTEM, DISC

FUNCTIONAL DESCRIPTION

The disc scrub system moves the scrub head up and down and turns the scrub motors on at off at the operator's request to provide floor scrubbing action. The discs spin toward the center at the front edge of each disc. The head is moved up and down by an electric actuator motor that has integrated position switches. The weight of the scrub head provides the downward pressure in the normal scrub mode. When extra pressure is requested the actuator moves down farther causing a gas spring to exert additional downward pressure on the floor.

The main machine controller energizes the brush solenoid to turn on the brush motors when the following inputs have been met:

- Key switch on
- Operator request – One Touch Control Button pressed
- Machine moving signal is received from PG Drive Motor Controller
 - o Approximately 17 volts received from the main controller (J1 Pin 4) is switched to battery negative by the Drive Motor Controller, dropping the voltage to 0 volts.

The main machine controller directly drives the brush head actuator. It applies system voltage across the two actuator motor wires to move the motor up. It reverses polarity to move the motor down. The brush head actuator also has 3 position switches built into it to let the main machine controller know how high or low the brush head is. Each switch receives a 5 volt feed through a resistor from the controller which returns back to battery negative on a common wire to connector J3 pin 7. The controller has "internal voltmeters" which monitors the signal voltage of each switch circuit. When the switch is closed, the voltage signal is nearly 0 volts. When the switch is open, the voltage is approximately 5 volts.

- Full Up Position = M0 is 5v (M1 and M2 are both 0v)
- Normal Scrub Position = M1 is 5v (M0 and M2 are both 0v)
- Extra Scrub Pressure Position = M2 is 5v (M0 and M1 are both 0v)

When the key is turned on the main machine controller looks to see if the brush head is fully up by monitoring the M0 switch voltage. If it is not 5v, it drives the actuator to the full up position. When the operator presses the One Touch Control Button the controller drives the actuator down until it sees the M1 switch open (5v). If the operator pushes the Increase Brush Pressure Button, the controller drives the actuator further down until it sees the M2 switch open (5v). When the operator pushes the One Touch Control Button again to turn the scrub function off, the controller drives the actuator motor up until it sees the M0 switch open again (5v).

Scrub System - Disc and Cylindrical

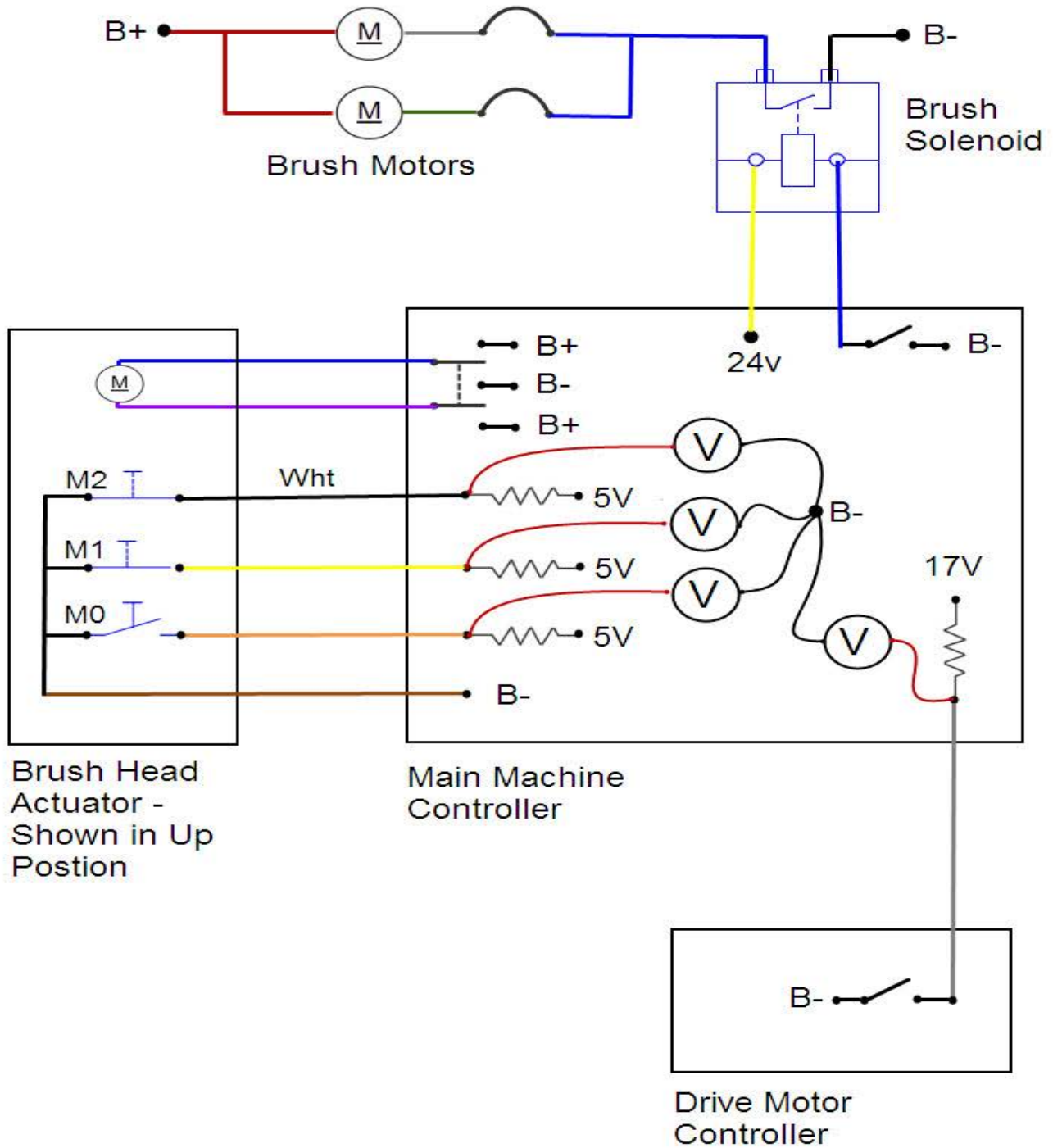

COMPONENT LOCATIONS

- Gas Spring
- Brush Head Actuator
- Brush Solenoid
- Main Machine Controller

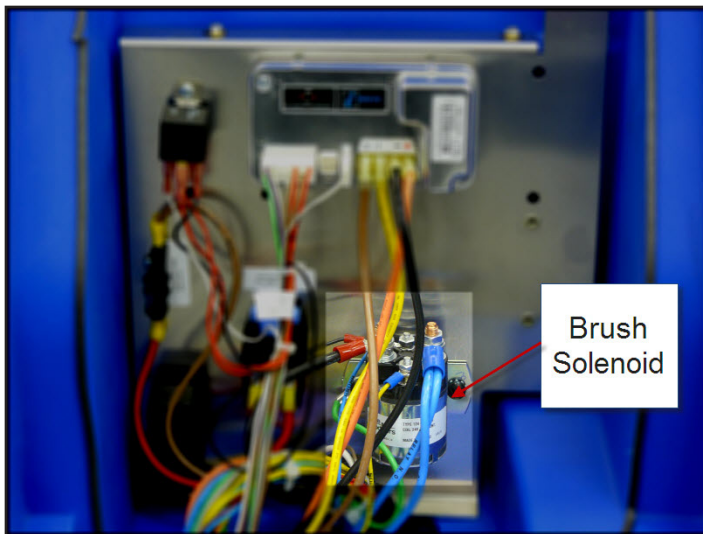
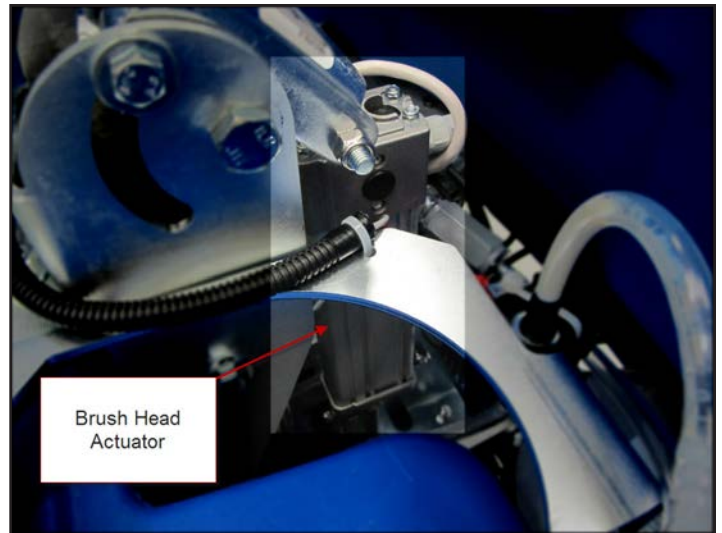

TROUBLESHOOTING

SCRUB MOTORS DO NOT TURN ON

Possible Causes

- Brush Solenoid (Contactor)
 - Open or shorted winding
 - Burned Contacts
- Wiring
- Main Machine Controller – Not energizing the brush solenoid.
- Drive Motor Controller – Not providing “machine moving signal”

SCRUB DECK WILL NOT RAISE OR LOWER

Possible Causes

- Brush Head Actuator
- Main Machine Controller
- Wiring

REMOVAL AND INSTALLATION

BRUSH HEAD

1. Remove plastic brush head covers.
2. Remove scrub brushes.
3. Loosen, but do not remove the 3 brush head mounting fasteners

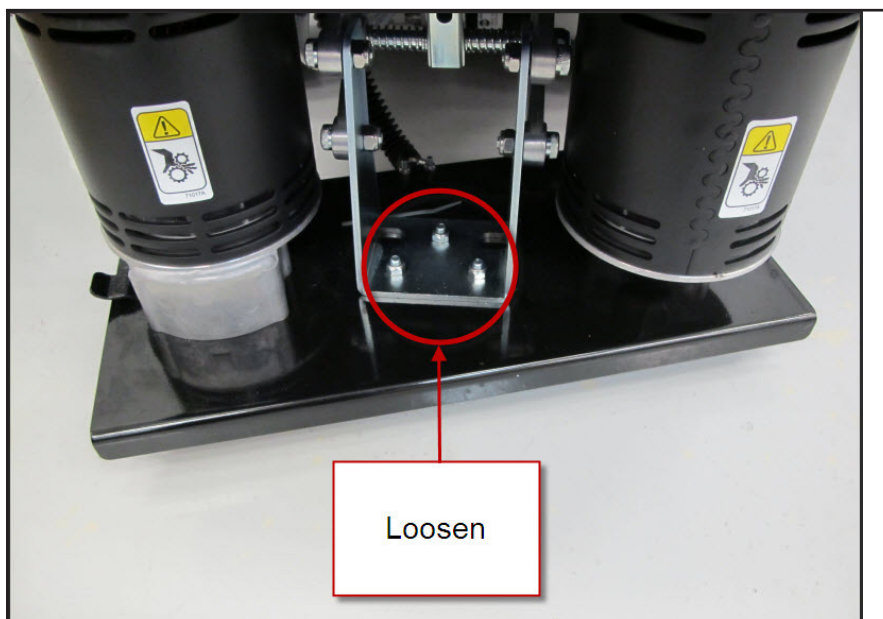

4. Turn the key on and press the one touch scrub button to lower the brush head to the floor. Then turn the key off leaving the brush head on the floor.
5. Disconnect scrub motor electrical connectors.
6. Disconnect the solution hose.
7. Remove the 3 brush head mounting fasteners.
8. Pull brush head out from under the machine.
9. Reassemble in reverse order.

SCRUB MOTOR CARBON BRUSHES – 26 AND 28 INCH BRUSH HEAD

1. Remove 2 through bolts.



2. Gently pry the end cover up and off of motor.

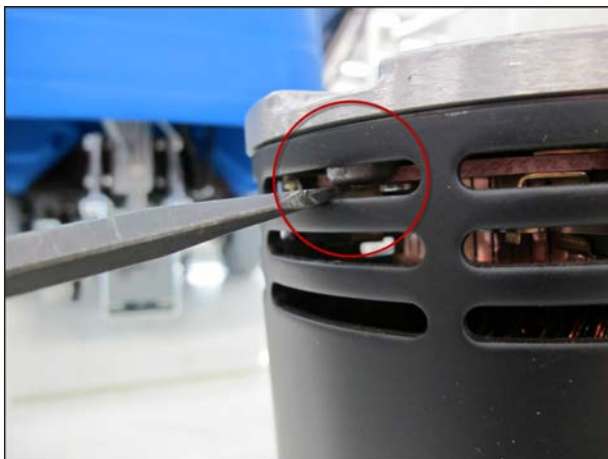

3. Replace carbon brushes.
 - a. Replace one brush at a time.
 - b. Push the brush all the way back so that the spring rests on the side of the brush rather than at the end of the brush this will hold the brush in place during assembly

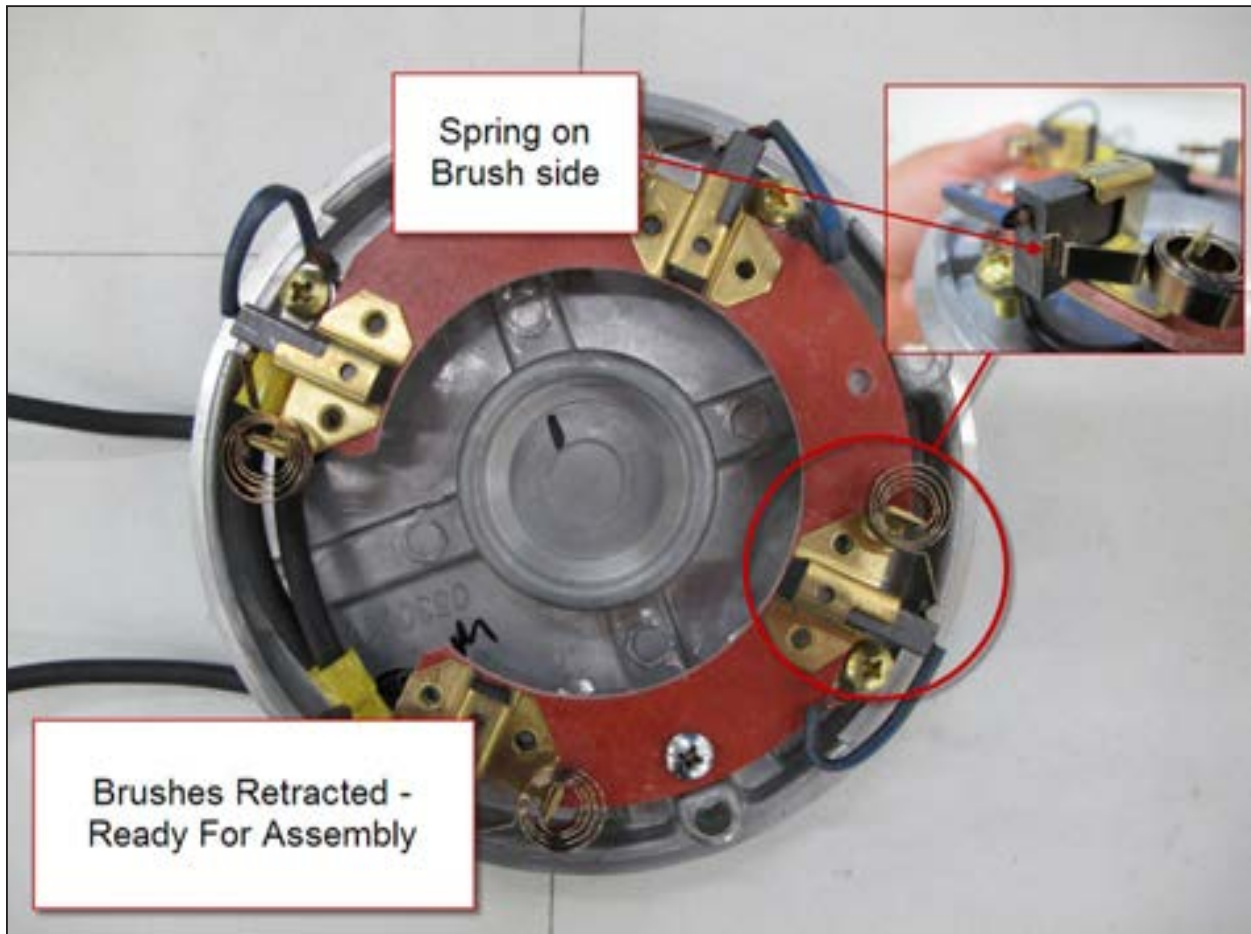

4. Make sure the wave washer is in place on the bearing before reassembling.



5. Reassemble in reverse order.

- a. After installing the end cover, push each carbon brush inward until the spring seats against the end of the brush. This can be done by working through the slots in the frame.

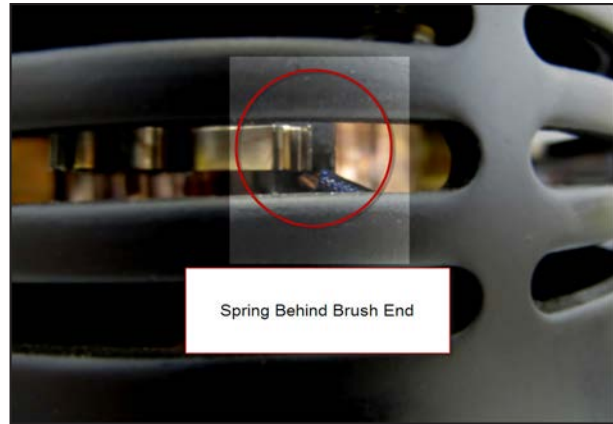
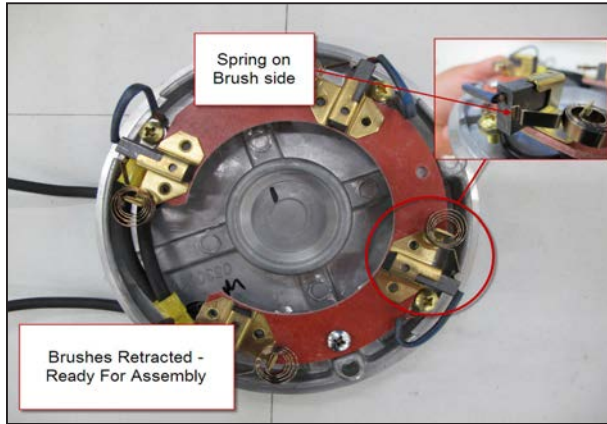

SCRUB MOTOR CARBON BRUSHES - 34 INCH BRUSH HEAD

- 1. Remove plastic fan cover (4 screws)



- 2. Remove two brush inspection covers.



3. Loosen the fan set screw and remove the fan.

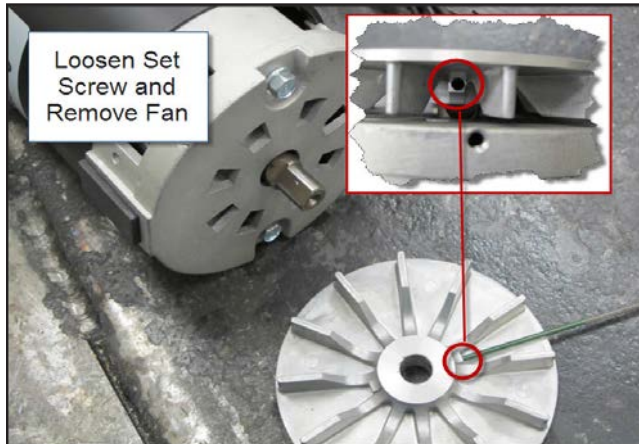

4. Remove 2 through bolts and pry the end cover off of the motor.



5. Replace carbon brushes.
 - a. Replace one brush at a time.
 - b. Push the brush all the way back so that the spring rests on the side of the brush rather than at the end of the brush this will hold the brush in place during assembly.

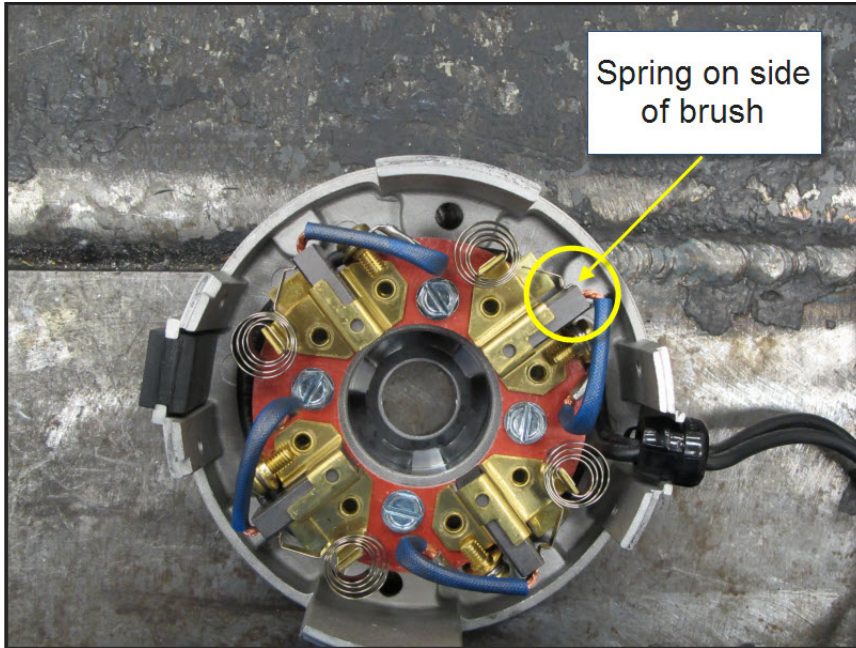

6. Reassemble in reverse order.

- a. After installing the end cover, push each carbon brush inward until the spring seats against the end of the brush.

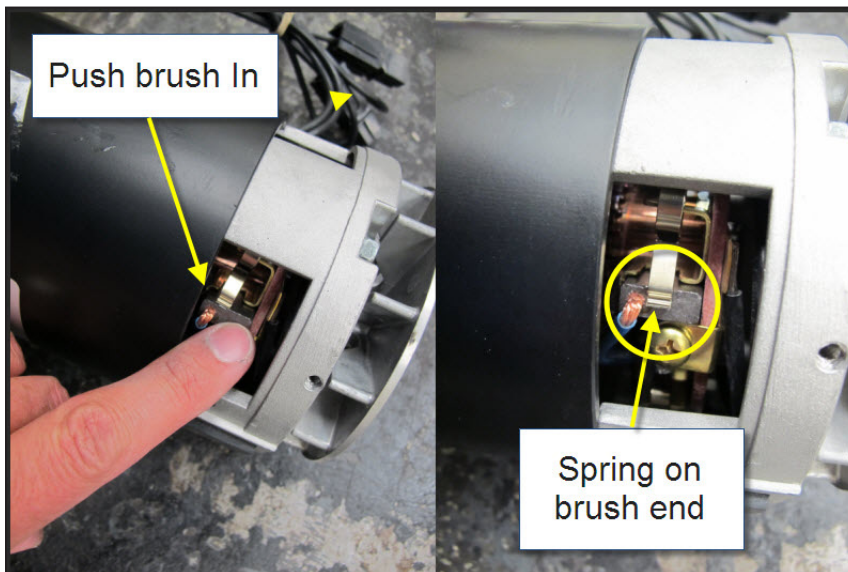

BRUSH HEAD ACTUATOR

1. Empty recovery tank.
2. Press the one touch control button to lower the brush head.
 - a. If the actuator does not move, slightly raise the brush head with a jack to take tension off of the mounting hardware
3. Turn key switch off.
4. Lift recovery tank up.
5. Disconnect electrical fastener.
6. Remove lower fastener.

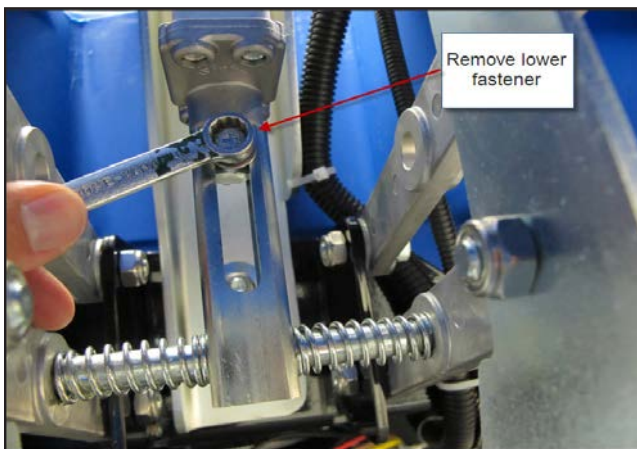

7. Remove upper fastener.

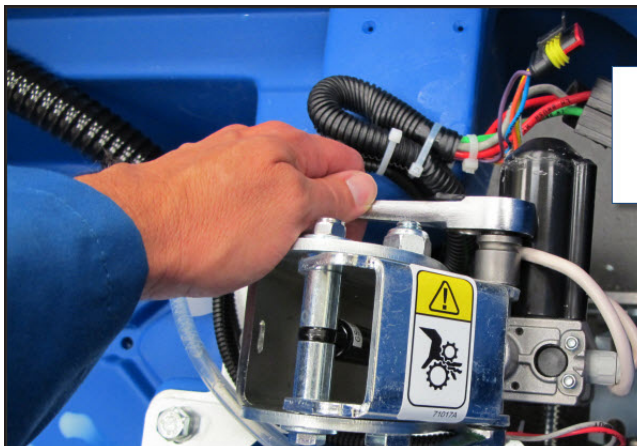

8. Remove actuator.
9. Reassemble in reverse order.

SPECIFICATIONS

SCRUB MOTOR AMP DRAW

No Load ~ 4 Amps

BRUSH HEAD ACTUATOR AMP DRAW

Up with weight of deck up - ~ 2-3 Amps

BRUSH CONTACTOR

Winding Resistance – 53 ohms

GAS SPRING

Force – 112 pounds (500 N)

SCRUB SYSTEM, ORBITAL (BOOST)

FUNCTIONAL DESCRIPTION

The disc scrub system moves the scrub head up and down and turns the scrub motor on at off at the operator's request to provide floor scrubbing action. The scrub pad is moved in an orbital motion by the scrub motor similar to an orbital sander. The head is moved up and down by an electric actuator motor that has integrated position switches. The weight of the scrub head provides the downward pressure in the normal scrub mode. When extra pressure is requested the actuator moves down farther causing a gas spring to exert additional downward pressure on the floor.

The main machine controller energizes the brush solenoid to turn on the brush motor when the following inputs have been met:

- Key switch on
- Operator request – One Touch Control Button pressed
- Machine moving signal is received from PG Drive Motor Controller
 - Approximately 17 volts received from the main controller (J1 Pin 4) is switched to battery negative by the Drive Motor Controller, dropping the voltage to 0 volts.

The main machine controller directly drives the brush head actuator. It applies system voltage across the two actuator motor wires to move the motor up. It reverses polarity to move the motor down. The brush head actuator also has 3 position switches built into it to let the main machine controller know how high or low the brush head is. Each switch receives a 5 volt feed through a resistor from the controller which returns back to battery negative on a common wire to connector J3 pin 7. The controller has "internal voltmeters" which monitors the signal voltage of each switch circuit. When the switch is closed, the voltage signal is nearly 0 volts. When the switch is open, the voltage is approximately 5 volts.

- Full Up Position = M0 is 5v (M1 and M2 are both 0v)
- Normal Scrub Position = M1 is 5v (M0 and M2 are both 0v)
- Extra Scrub Pressure Position = M2 is 5v (M0 and M1 are both 0v)

When the key is turned on the main machine controller looks to see if the brush head is fully up by monitoring the M0 switch voltage. If it is not 5v, it drives the actuator to the full up position. When the operator presses the One Touch Control Button the controller drives the actuator down until it sees the M1 switch open (5v). If the operator pushes the Increase Brush Pressure Button, the controller drives the actuator further down until it sees the M2 switch open (5v). When the operator pushes the One Touch Control Button again to turn the scrub function off, the controller drives the actuator motor up until it sees the M0 switch open again (5v).

Scrub System - Boost

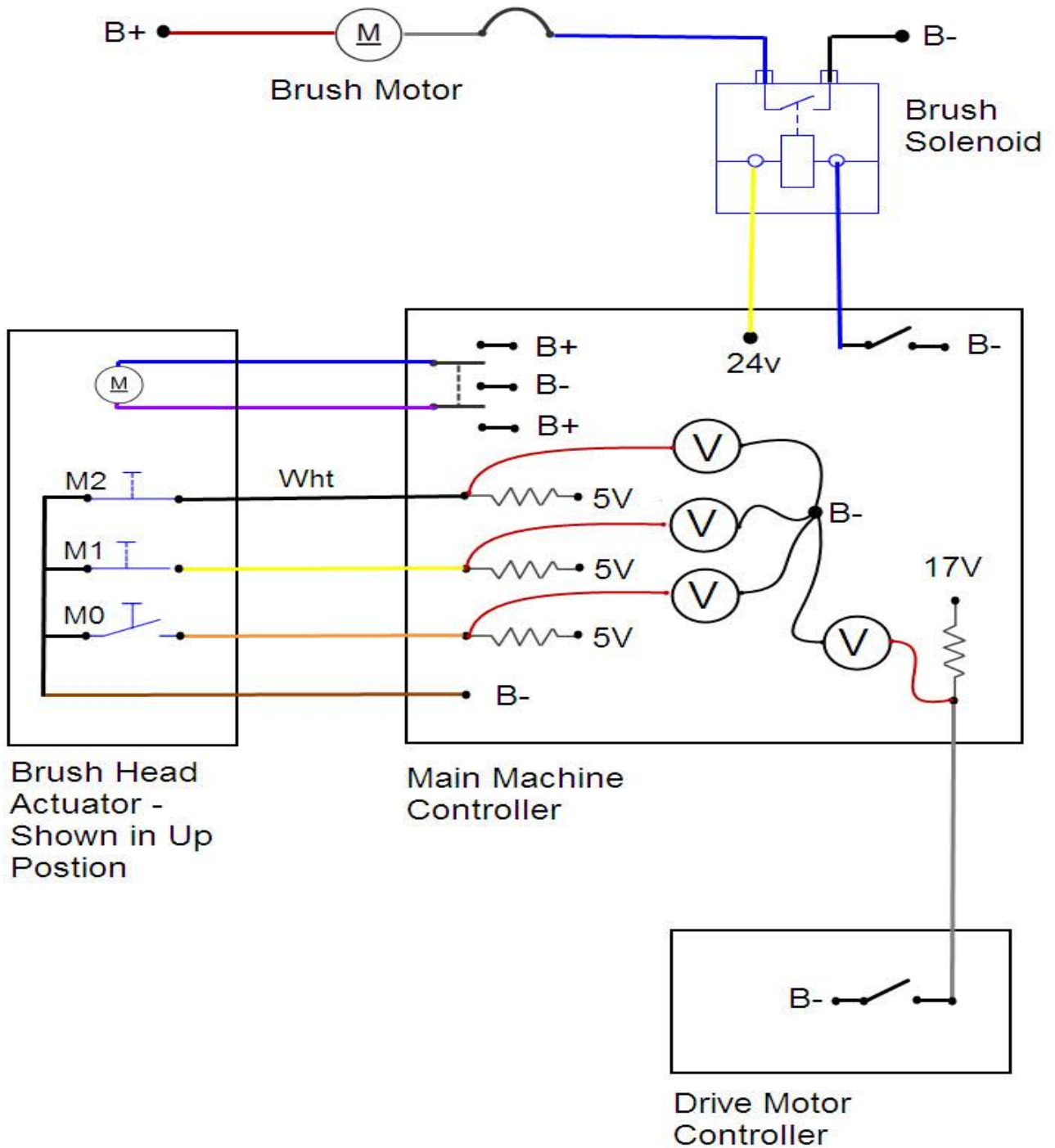

COMPONENT LOCATIONS

- Gas Spring
- Brush Head Actuator
- Brush Solenoid
- Main Machine Controller

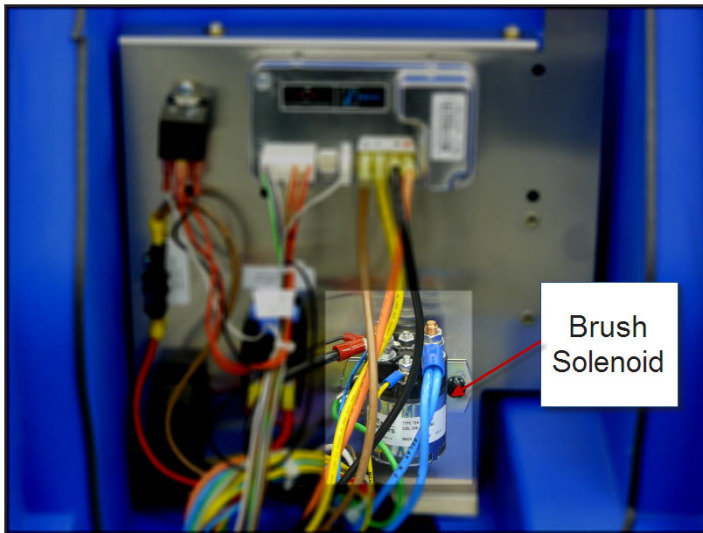
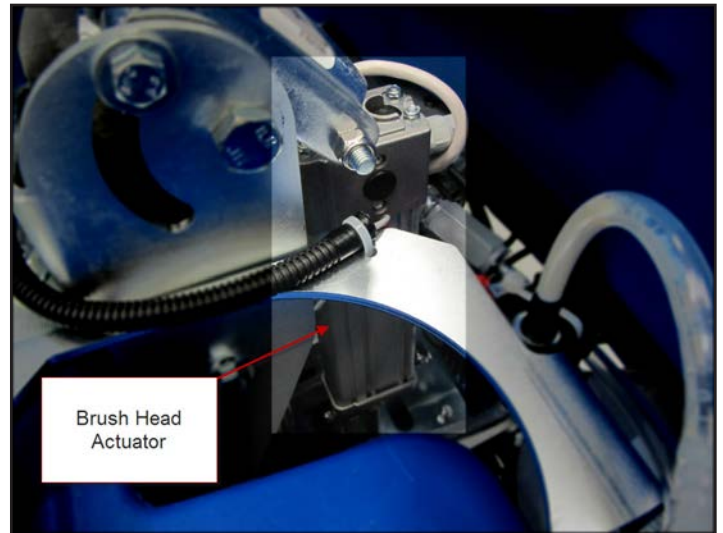

TROUBLESHOOTING

SCRUB MOTOR DOES NOT TURN ON

Possible Causes

- Scrub Motor
- Brush Solenoid (Contactor)
 - Open or shorted winding
 - Burned Contacts
- Wiring
- Main Machine Controller – Not energizing the brush solenoid.
- Drive Motor Controller – Not providing “machine moving signal”

SCRUB DECK WILL NOT RAISE OR LOWER

Possible Causes

- Brush Head Actuator
- Main Machine Controller
- Wiring

REMOVAL AND INSTALLATION

BRUSH HEAD ASSEMBLY

1. Lower the brush head to the floor by turning the key switch on and pressing the one touch scrub button.
2. Turn off the key switch.
3. Disconnect solution hose.



4. Disconnect the brush motor electrical connection.
5. Remove the nuts, bolts and plastic bushing securing the brush head lift brackets to the lift arms.
 - a. Make a note of plastic bushing positions for reassembly.

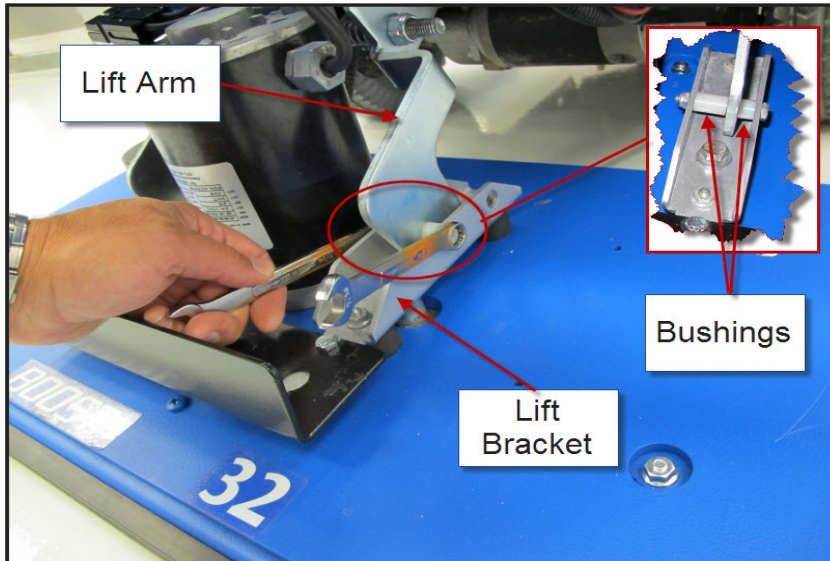

6. Reassemble in reverse order

ISOLATORS AND MOUNTS

1. Remove the brush head assembly and place it on bench with scrub surface down. (see REMOVAL AND INSTALLATION - BRUSH HEAD ASSEMBLY)
2. Remove the front guard.

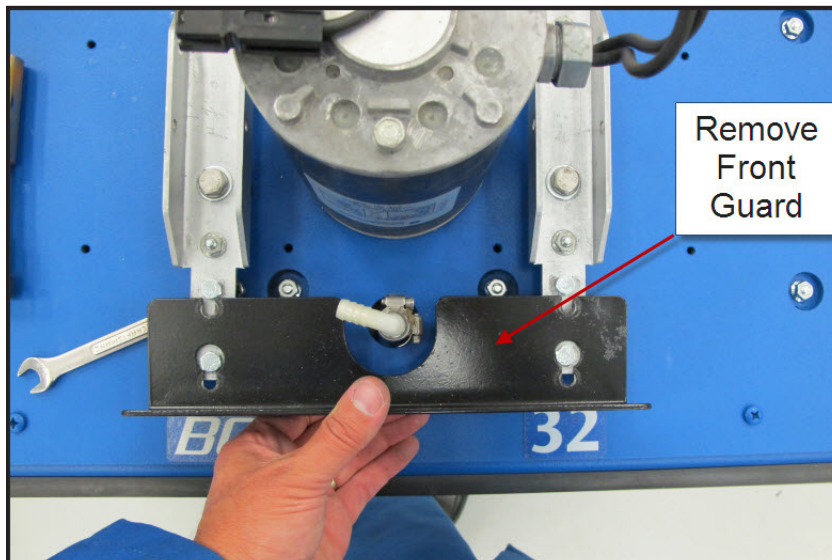

3. Remove isolator mounting nuts.

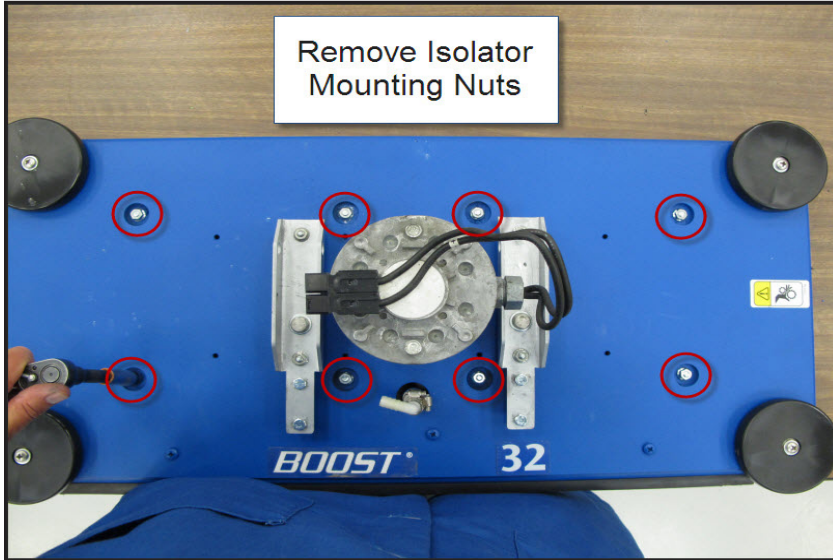

4. Flip head up.
5. Remove 4 screws attaching the flex plates to the driver plate.

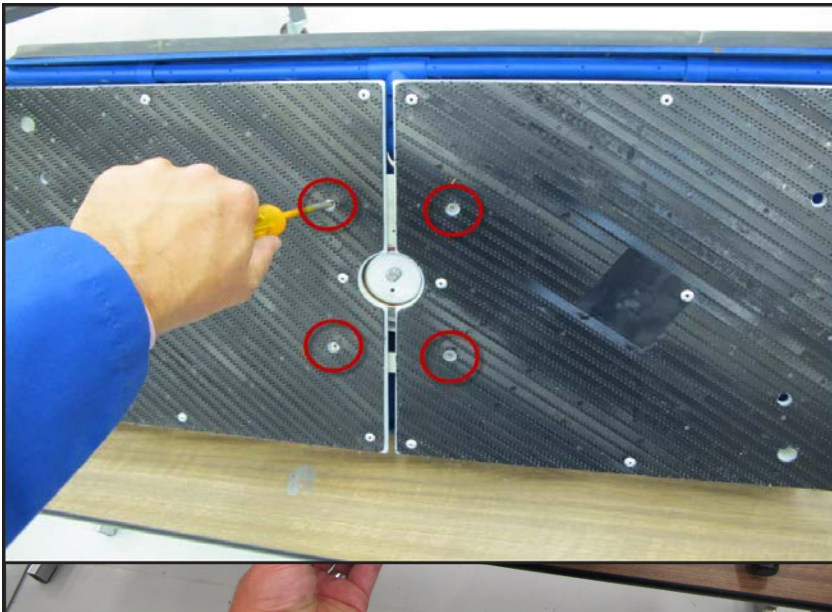

6. Remove both flex plates.

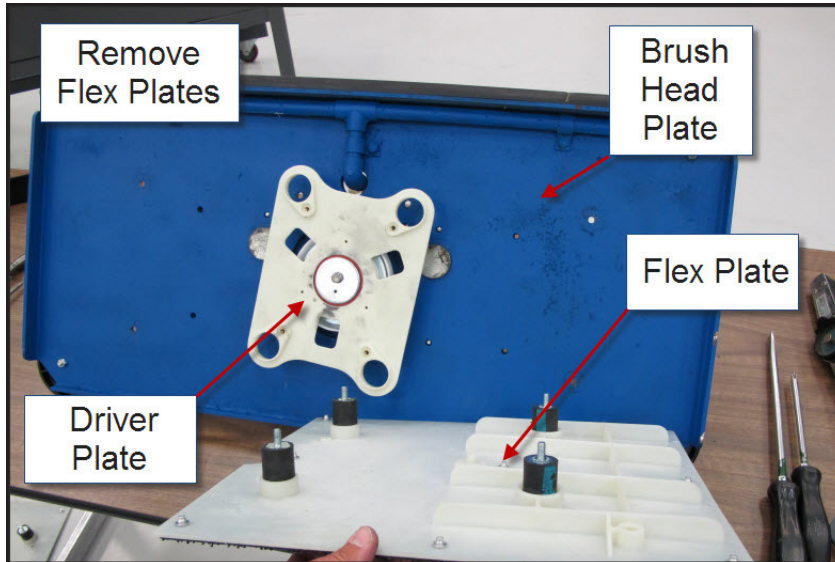

7. Remove lift brackets from brush head assembly.
 - a. Remove bolt from stud stabilizer on each side.
 - b. Remove rubber mount attaching nuts on each side.

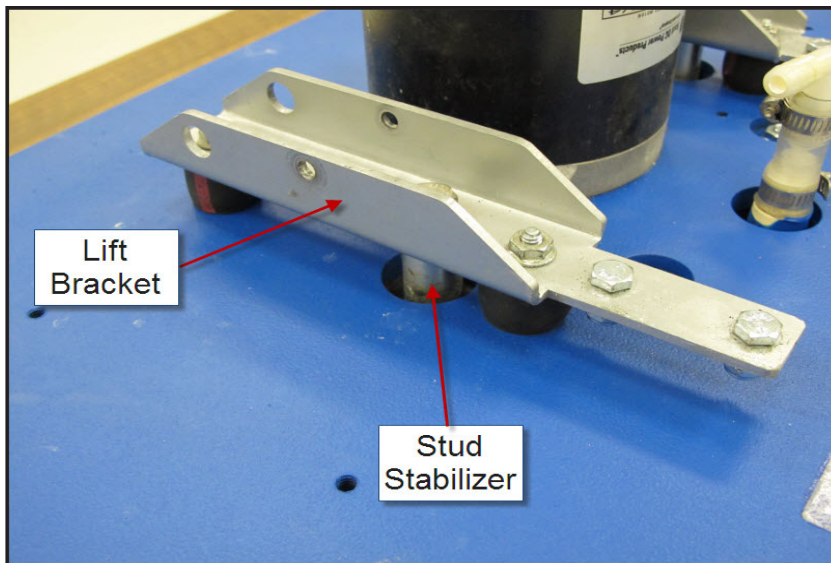

8. Remove rubber mounts from brush head plate.

9. Install new rubber mounts in brush head plate by hand.

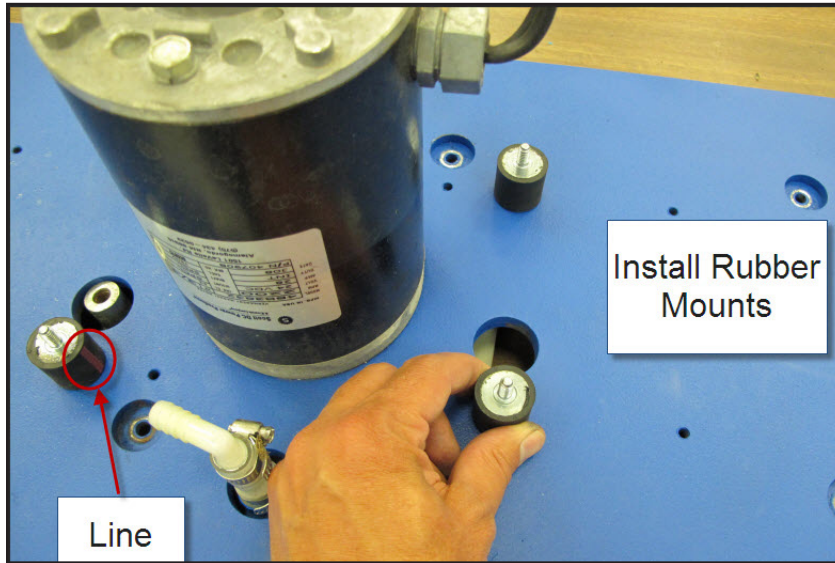

10. Install lift brackets to brush head.
 - a. Apply Loctite 242 to rubber mount stud threads.
 - b. Install and Torque nuts to 8-10 ft.-lbs.
 - i. **IMPORTANT!** After tightening the nuts, look at the lines on the rubber mounts and make sure they are not twisted, which indicates they are over tightened.
11. Install stud stabilizers and bolts on both sides.
12. Remove isolators from flex plates.
13. Install new rubber isolators by hand.



14. Install one flex plate at a time to the brush head – make sure you use the star lock washer between the isolator and the brush head plate.

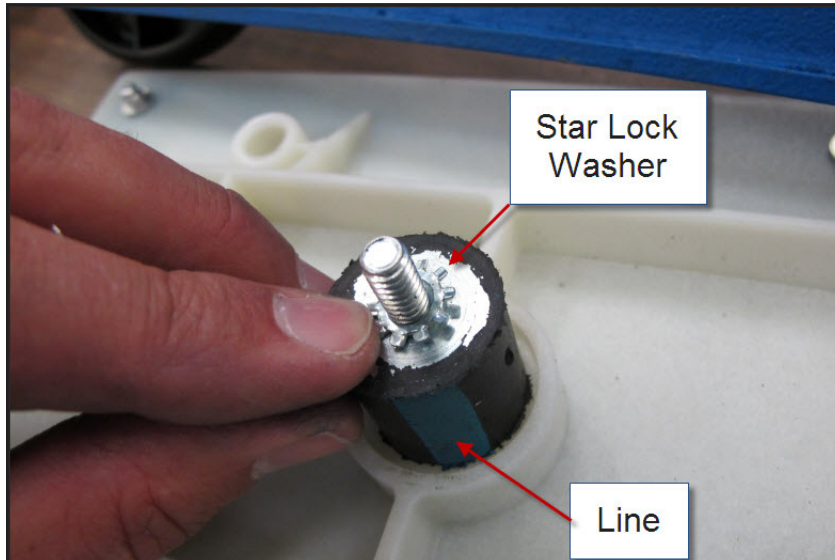

- a. Tip: start with one of the inner isolators. Install the star washer and direct the isolator through the hole in the drive plate and the stud through the hole in the brush head plate. Once stud is through the plate, loosely install the nut to hold it in place. Repeat this on the next inner isolator. Then attach the outer isolators to the brush head plate. If the holes are not lining up well, rotate the motor armature.
15. Install screws that attach flex plates to the driver plate.
 16. Flip head so that flex plates are down.
 17. Torque the flex plate isolator nuts to 8-10 ft.-lbs.
 - a. **IMPORTANT!** After tightening the nuts, look at the lines on the rubber isolators and make sure they are not twisted, which indicates they are over tightened.
 18. Install the front guard.

SCRUB MOTOR CARBON BRUSHES

1. Remove wire retaining nut and rubber packing.

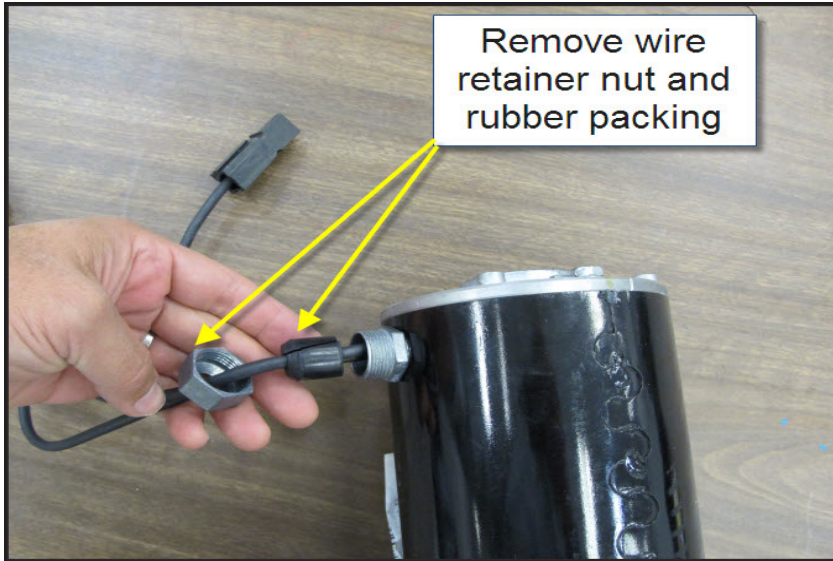

2. Remove both through bolts.

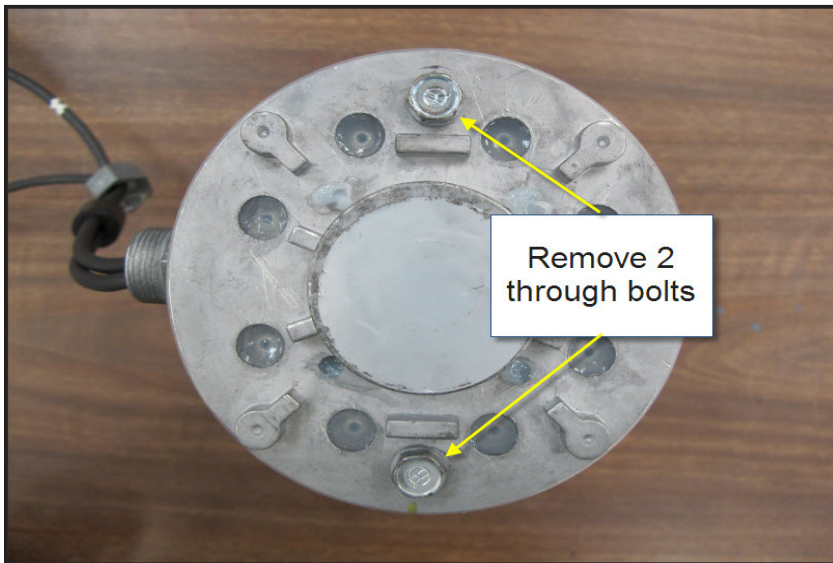

3. Remove end plate.

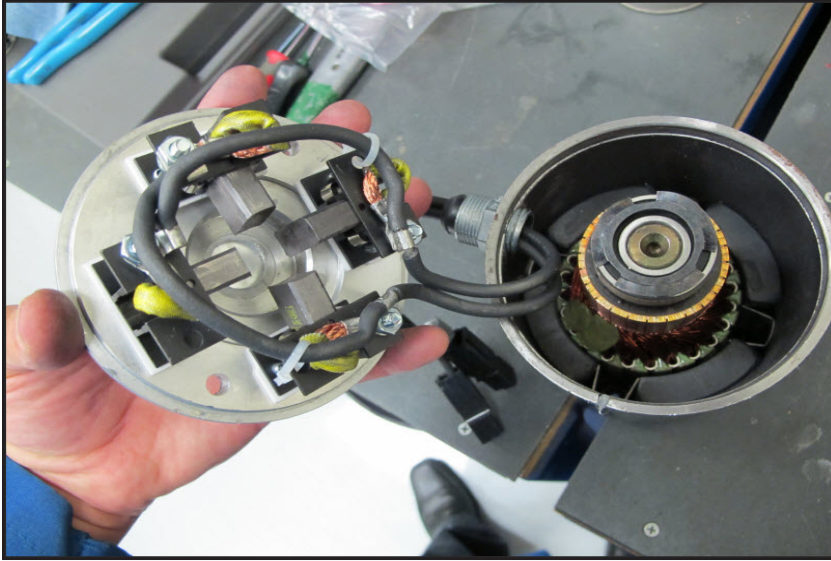

4. Replace the carbon brushes

- a. Observe how the springs roll when the brush is pushed back before taking it apart.
- b. Remove a brush and spring.
- c. Install a new brush and spring into the brush holder. Thread the brush wire lead through the brush holder. Position the back end of the brush in the "cup" of the spring so that the spring will unroll as the brush is pushed back once it is installed.

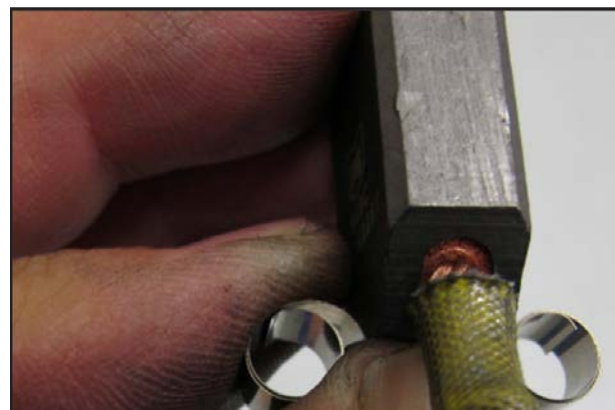
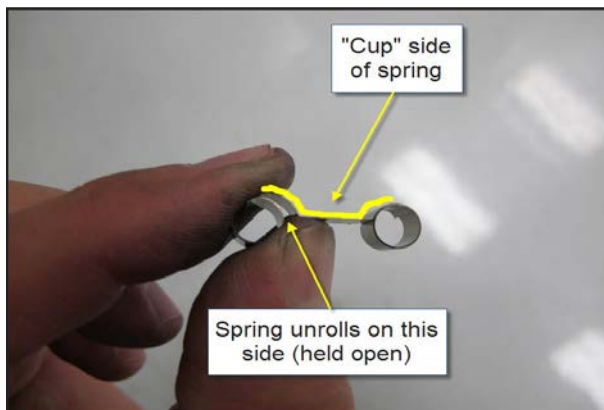

- d. Push brush back against the spring and insert a stiff temporary retaining wire (Paper clip) through the access hole in the end cover. (Remove silicone sealer from the holes) The wire must go through the holes in the brush holder just in front of the brush to hold the brush back against the spring pressure.

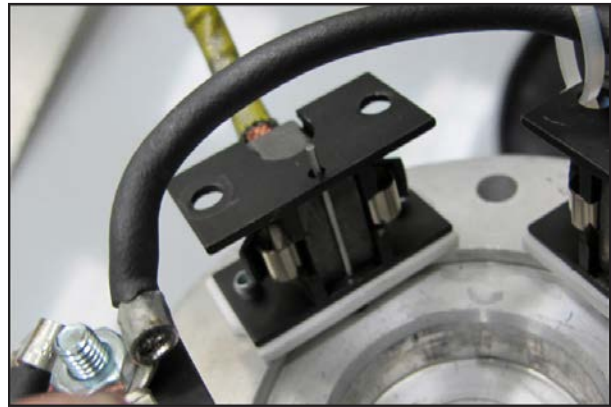
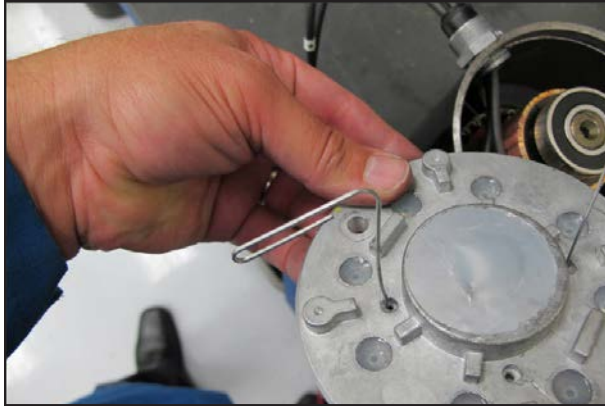

- e. Install the other three brushes
5. Install the wave washer.
 6. Install the end cover in stages.
 - a. Install it far enough so that the brushes will contact the commutator when the temporary retaining wires are removed. Then remove the wires.

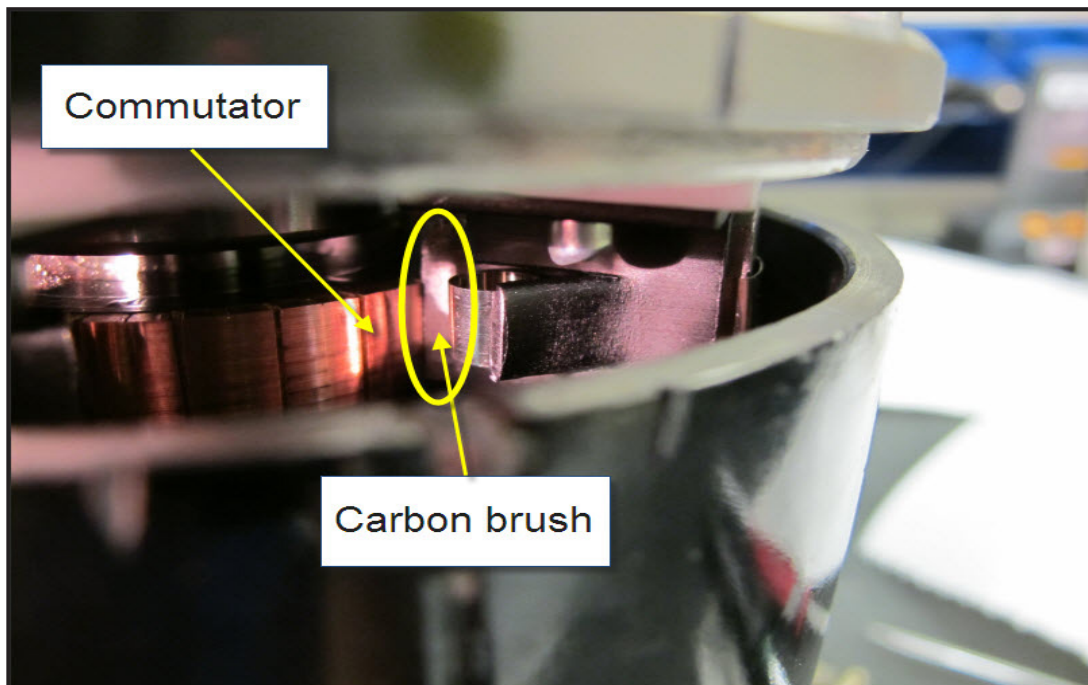

- b. Fully seat the end cover.
- c. Install the through bolts.

- d. Seal the retaining wire holes in the end cover with silicone sealant.

BRUSH HEAD ACTUATOR

1. Empty recovery tank.
2. Press the one touch control button to lower the brush head.
 - a. If the actuator does not move, slightly raise the brush head with a jack to take tension off of the mounting hardware
3. Turn key switch off.
4. Lift recovery tank up.
5. Disconnect electrical fastener.
6. Remove lower fastener.

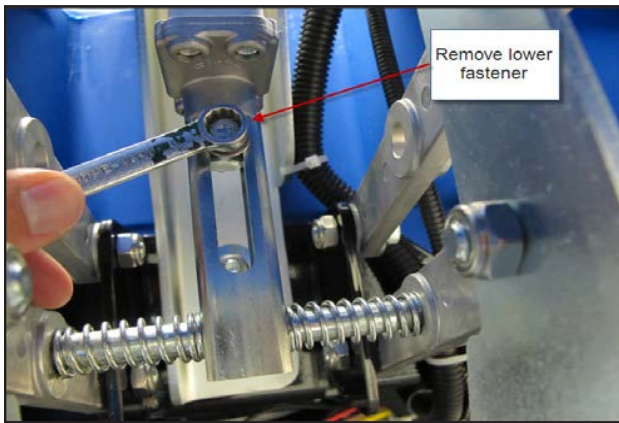

7. Remove upper fastener.



8. Remove actuator.
9. Reassemble in reverse order.

BRUSH HEAD MOTOR

The brush head motor is attached with 4 screws from the bottom side of the steel plate.

1. Follow steps 1 – 6 in REMOVAL AND INSTALLATION - ISOLATORS AND MOUNTS
2. Remove driver plate
 - a. Remove armature shaft bolt. (The armature will spin as you try to loosen the bolt. Use a screwdriver between the eccentric and the steel plate to prevent it from turning so you can loosen the bolt)
 - b. Lift off driver plate and retainer.

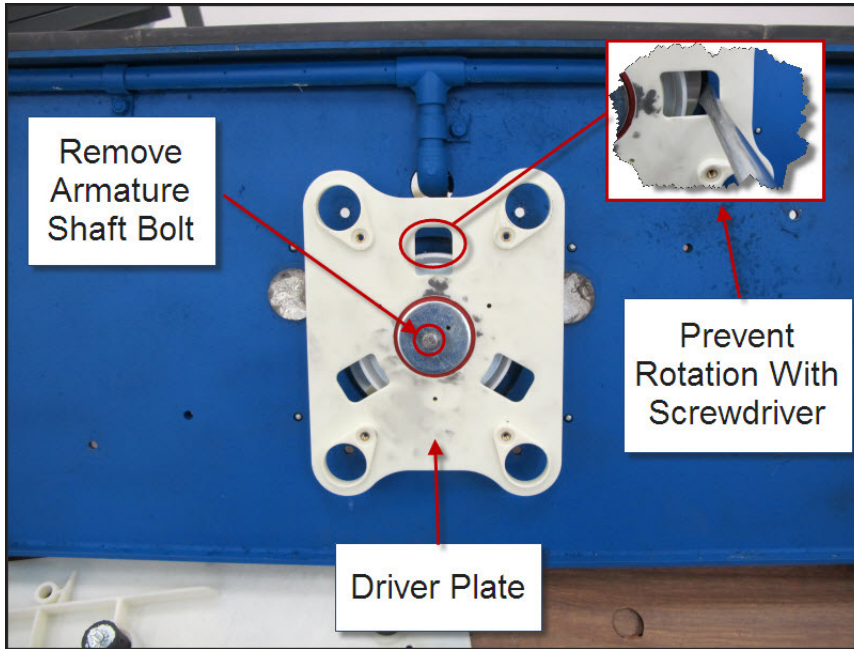

3. Remove bearing shield and eccentric.

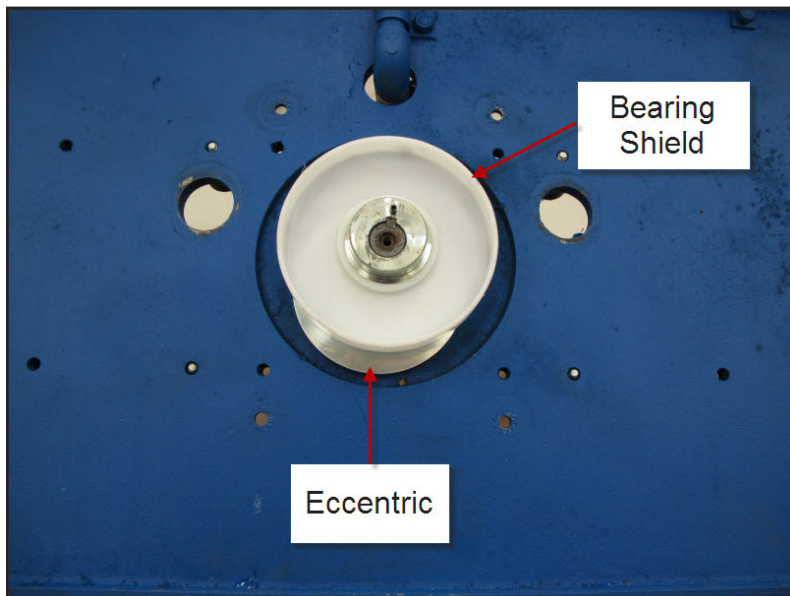

4. Remove motor mounting screws and remove the motor from the plate.

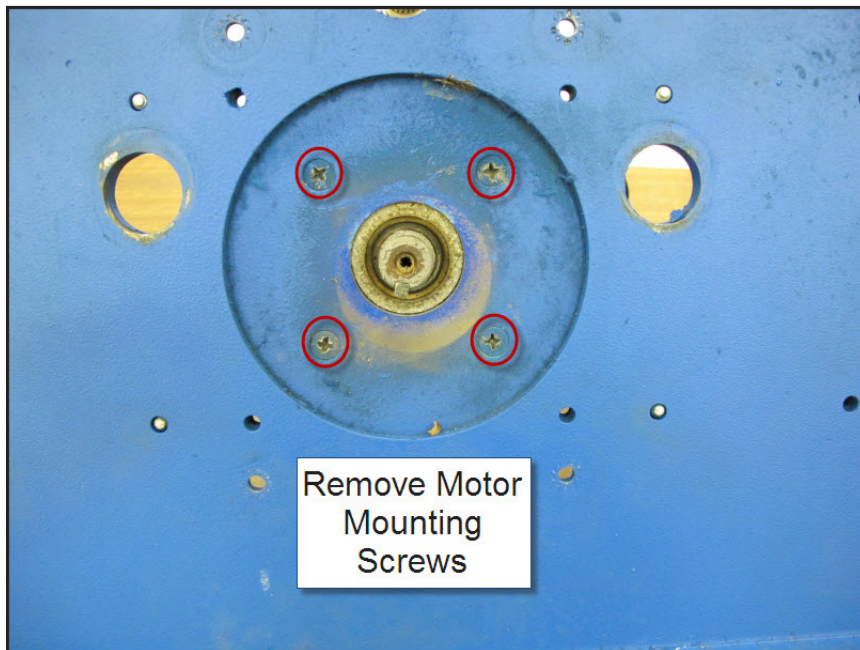

SPECIFICATIONS

BRUSH HEAD ACTUATOR AMP DRAW

Up with weight of deck up - ~ 2-3 Amps

BRUSH CONTACTOR

Winding Resistance – 53 ohms

GAS SPRING

Force – 112 pounds (500 N)

SOLUTION SYSTEM

FUNCTIONAL DESCRIPTION

The solution system dispenses the water and cleaning chemicals to the scrub brush head for scrubbing the floor. The solution tank holds the solution and serves as the main body of the scrubber. Solution from the tank flows through a manual shut off valve, filter, solution valve (solenoid), manifold and out to the deck. The filter protects the solution valve from debris which can damage the valve. The manual shut off valve makes it possible to service plumbing components without draining the solution tank.

The standard solution system requires the operator to mix a cleaning chemical with the water in the solution tank. An electric solution valve is used to turn the solution flow on and off as well as to meter the amount of solution used. The solution valve is controlled by the main machine controller.

The optional chemical mixing system automatically mixes water from the solution tank with chemical directly from the manufacturer's chemical container. The operator fills the solution tank with water only. The machine then automatically mixes the correct amount of cleaning chemical and water and delivers it to the scrub brush head.

On all machines, the main machine controller turns the solution flow on and off and meters the amount that flows via an electric solution valve based on operator request and whether or not the machine is moving. The solution is off when the machine is not moving and is turned on when it is moving. The main machine controller sends 17v out through a resistor on a gray wire to the drive motor controller. The drive motor controller has an internal switch that switches the circuit to battery negative whenever the machine is moving. The main machine controller has an internal voltmeter that monitors the circuit. When it sees 17 volts, it knows the machine is standing still. When it sees the voltage drop to near zero it knows the machine is moving and it then turns on the solution flow. To make the solution flow, the main machine controller provides a constant battery voltage supply going out of the brown wire, through the solution valve solenoid winding and returning to a switch inside the controller on the green wire. The main machine controller provides a switched path to battery negative to turn on the solution valve and allow solution to flow.

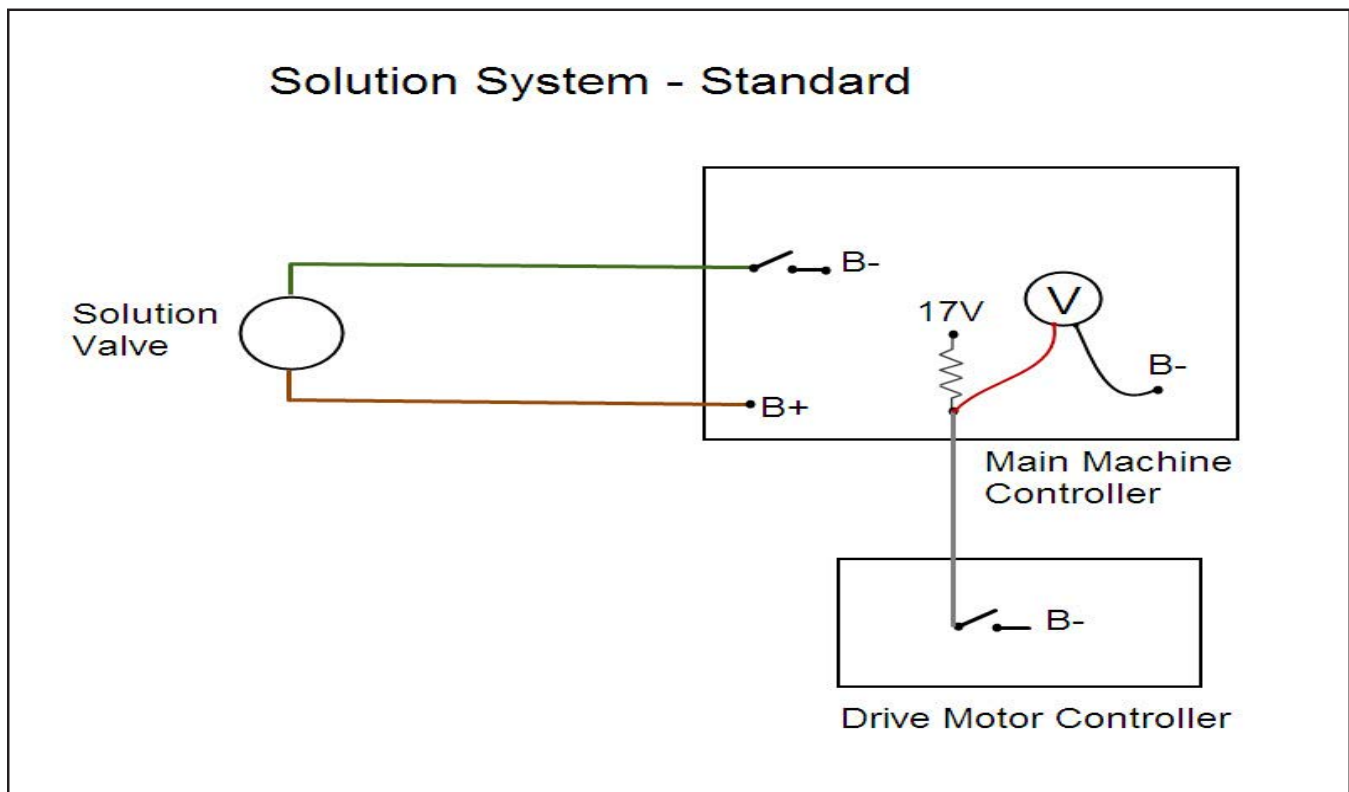

If the operator has requested low solution flow rate (first two LED segments), the controller will switch the circuit on for about 1 seconds and off for about 2 seconds. It will then continue this cycle. For medium solution flow rate (first 4 LED segments), the circuit will be on for 2 seconds and off for 1. For high solution flow rate (all 6 LED segments), the circuit will be on continuously. Figure 2 illustrates the solution valve control signal for all 3 flow rates. When the signal is “high”, the valve is off (closed). When the signal is “low”, the valve is open (on).

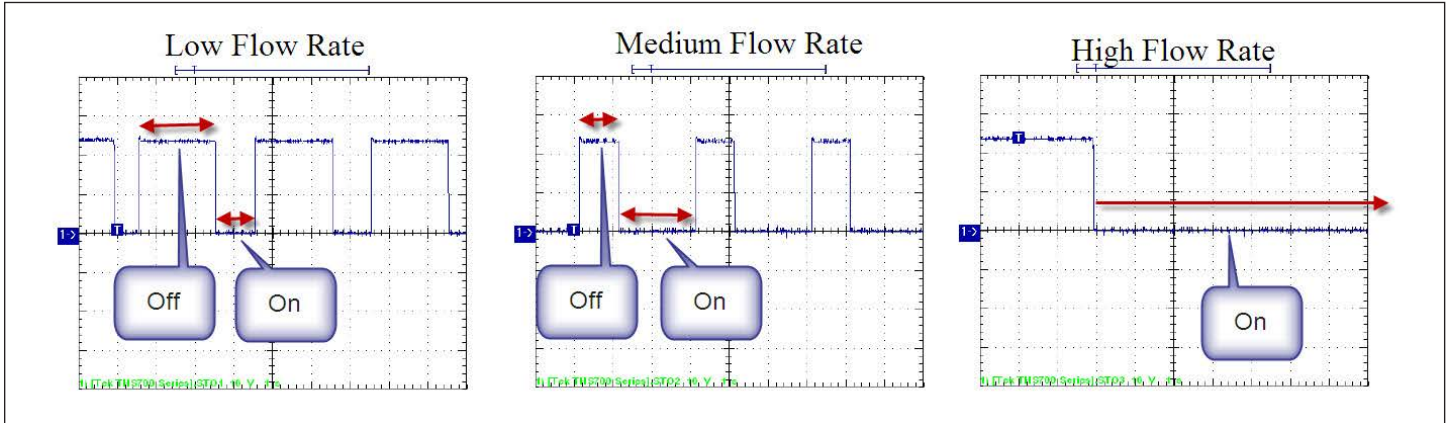

Figure 2 - Scope picture of solution valve control for all 3 flow rates.

On machines with the optional chemical mixing system there is an additional Chemical Soap Module that controls the amount of chemical added to the water via an electric piston type chemical pump. The soap module monitors the solution valve operation, frequency switch (jumper connection) and the chemical potentiometer via “internal voltmeters” to determine the correct amount of soap to add.

The main operator input is from the chemical mixing potentiometer. The chemical soap module supplies a 5v regulated (may read 4.6v) feed to one side of the potentiometer and provides a connection to battery negative on the other side. The “wiper signal” is monitored by the module on the blue wire. To request a small amount of chemical the potentiometer is rotated so that the wiper is near the battery negative side causing the voltage signal to be near zero. As the potentiometer is rotated toward the “more chemical” direction, the voltage on the signal wire increases until it reaches the maximum position where it will read close to 5 volts.

A frequency switch, which is really a set of jumper wires, is used to customize the system to the type of scrub deck. The Boost deck has a fitting that reduces the amount of total solution flow. When a boost deck is used, this switch input tells the controller to reduce the amount of soap being added to match the solution flow. The connector is left disconnected on a machine with a boost deck.

Every time the main machine controller energizes the solution valve, the soap module cycles the chemical pump on and off to pump the right amount of chemical (soap) into the solution line to mix with the water. If the operator has requested a small amount of chemical, the chemical pump will be cycled on and off just a few times each time the solution valve is on. If the operator has requested a lot of chemical, the chemical pump will be cycled on and off many times. (Note: If you put your hand on the chemical pump, you can feel the number of times it pumps each cycle.)

Solution System - With Optional Chemical Mixing System

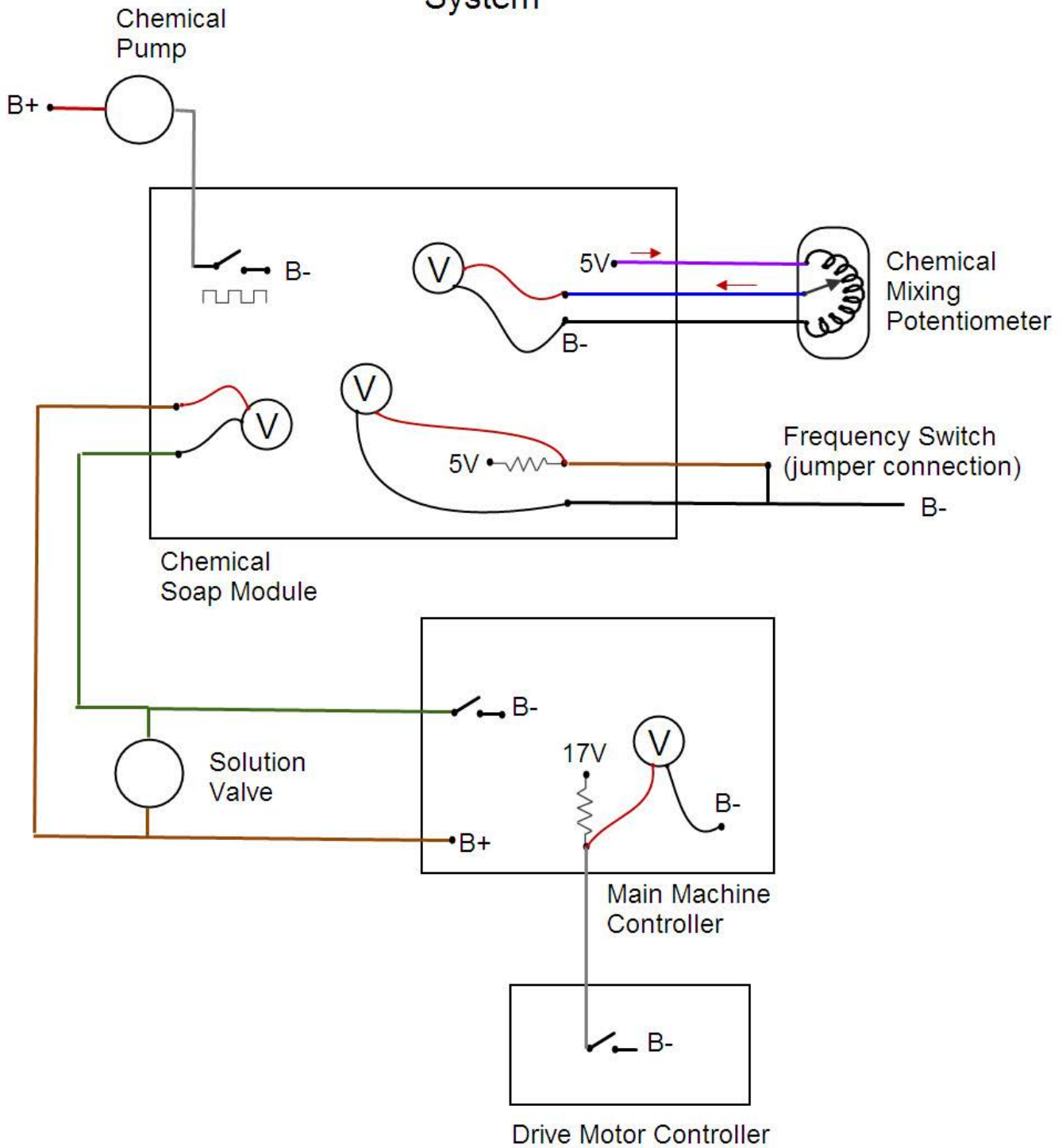

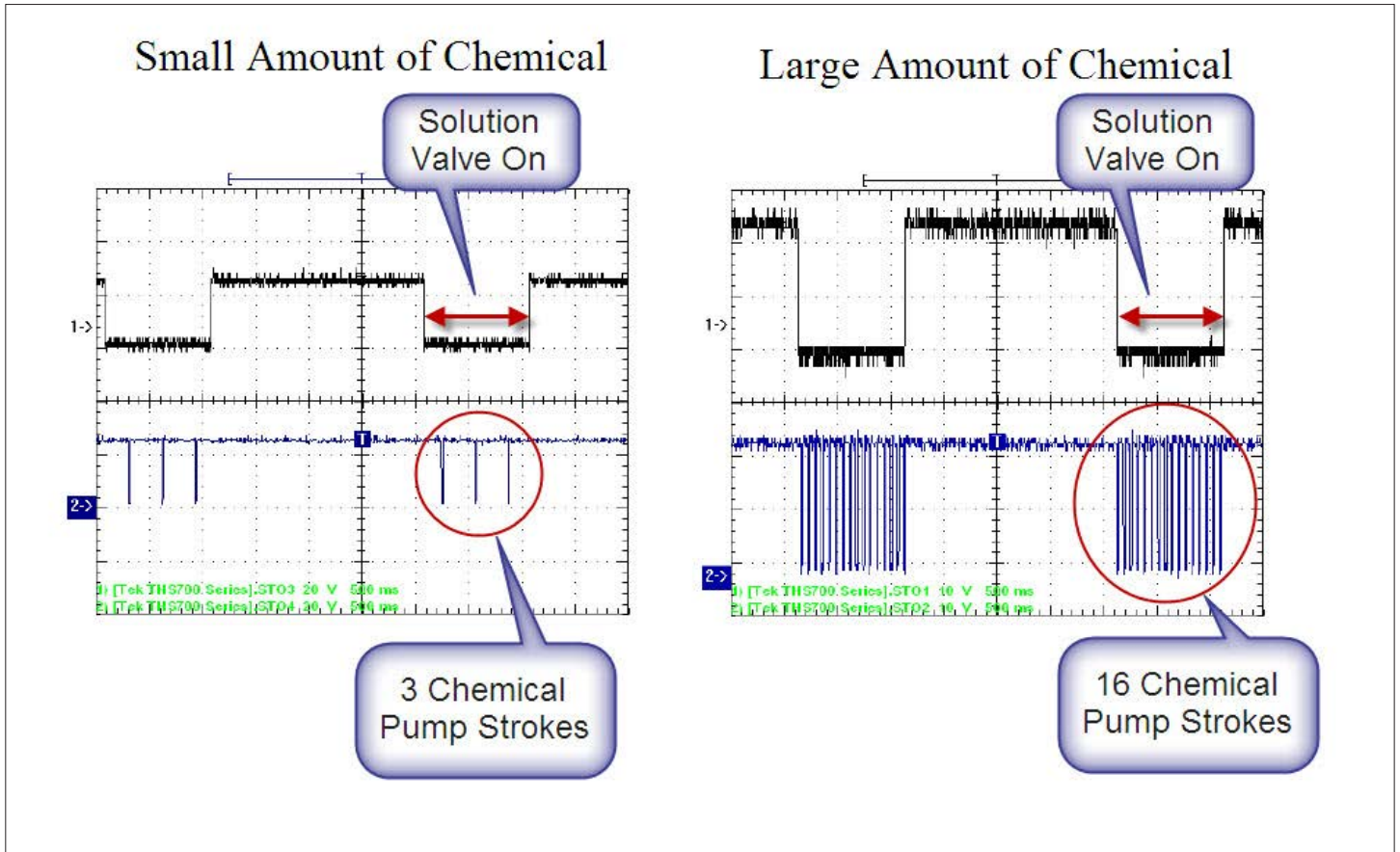
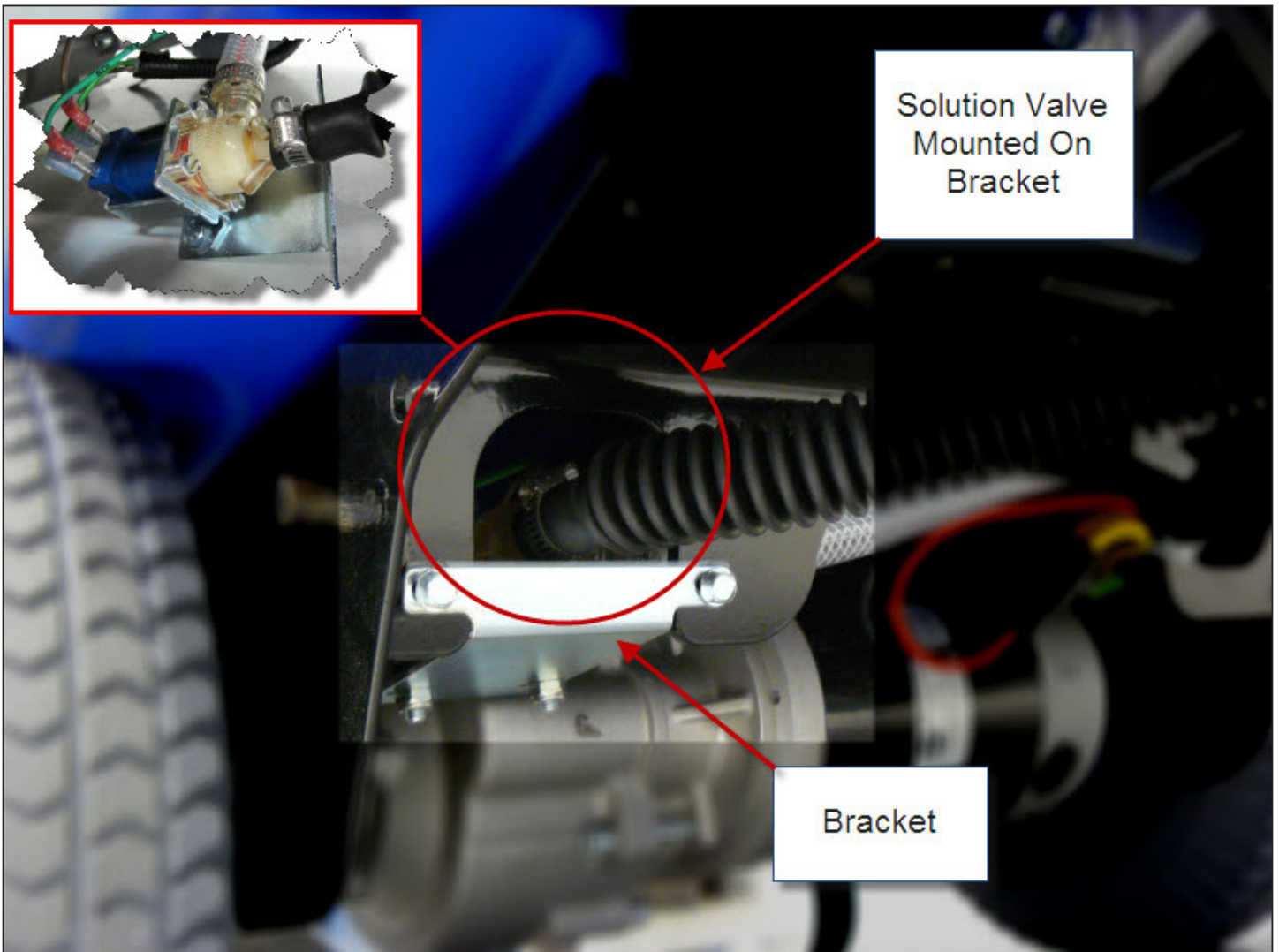
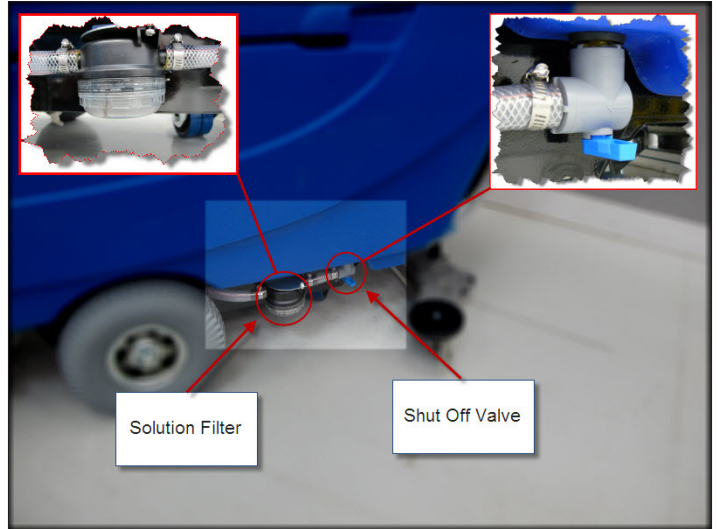
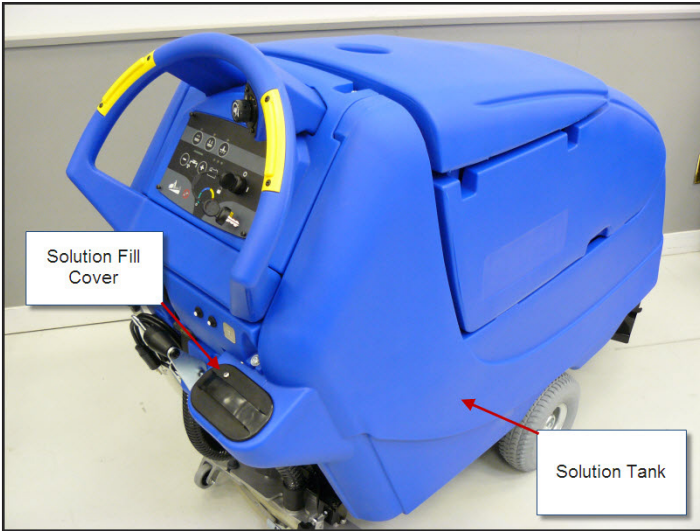
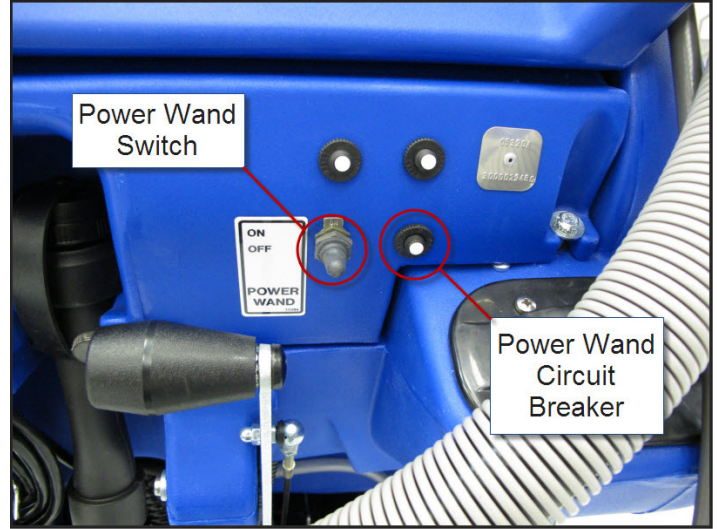
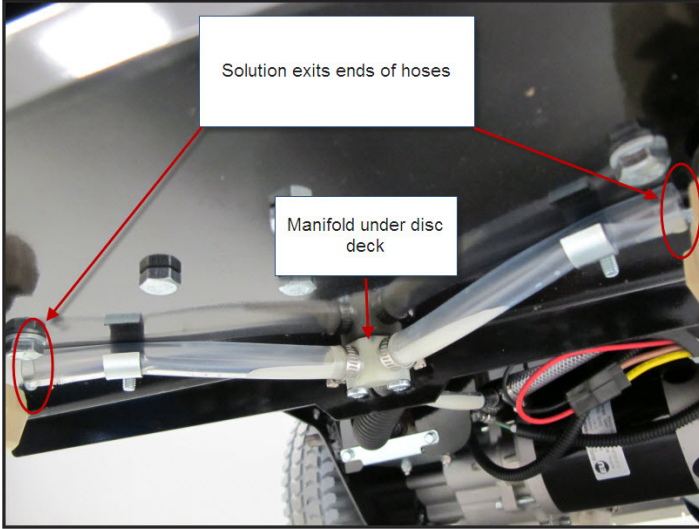

Figure 3 - Captured Scope Patterns of Chemical Pump Control.

COMPONENT LOCATIONS

- Common to all machines
 - o Solution Tank
 - o Tank fill opening and cover
 - o Shut off valve
 - o Solution filter
 - o Solution Valve
 - o Manifold fitting (disk deck)





- Machines will optional chemical mixing system
 - o Chemical Mixing Pump
 - o Chemical Mixing Potentiometer
 - o Chemical Mixing Module
 - o Chemical Mixing Check Valve
 - o "Frequency Switch"

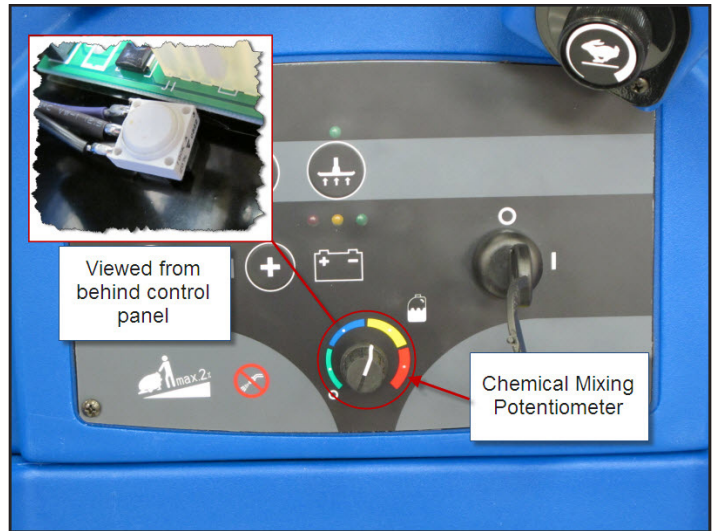
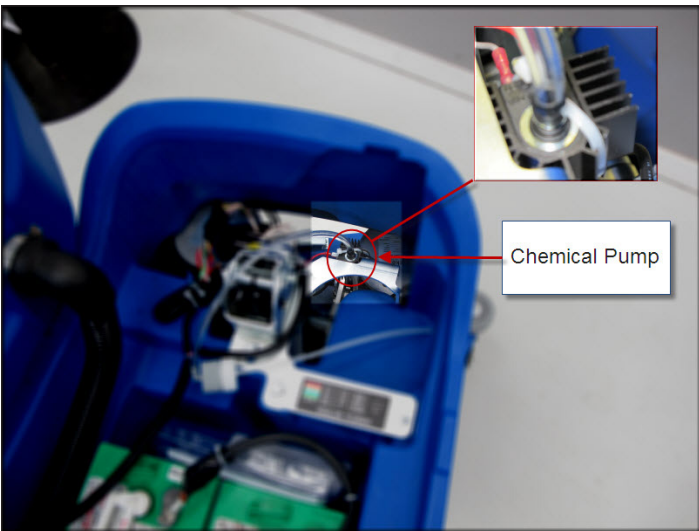

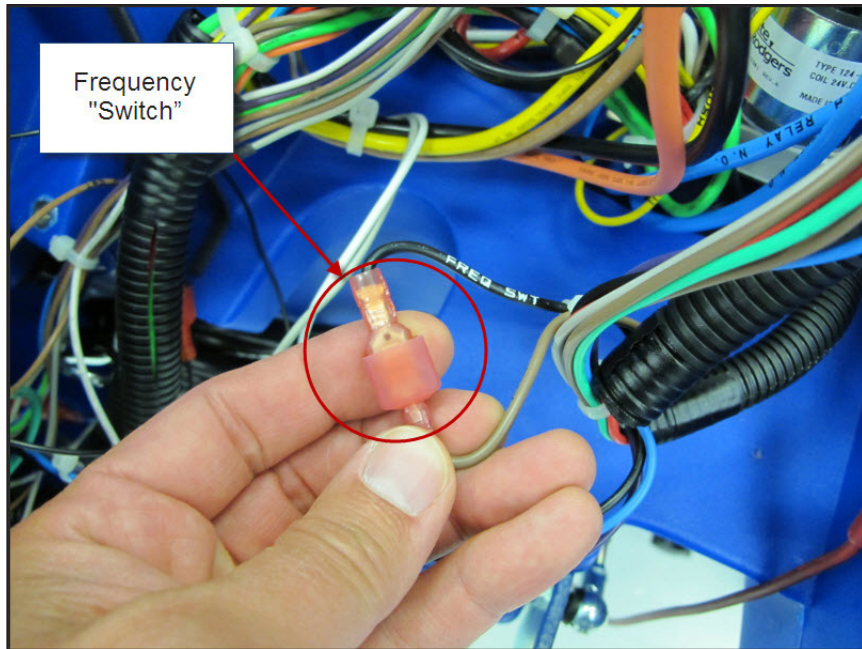
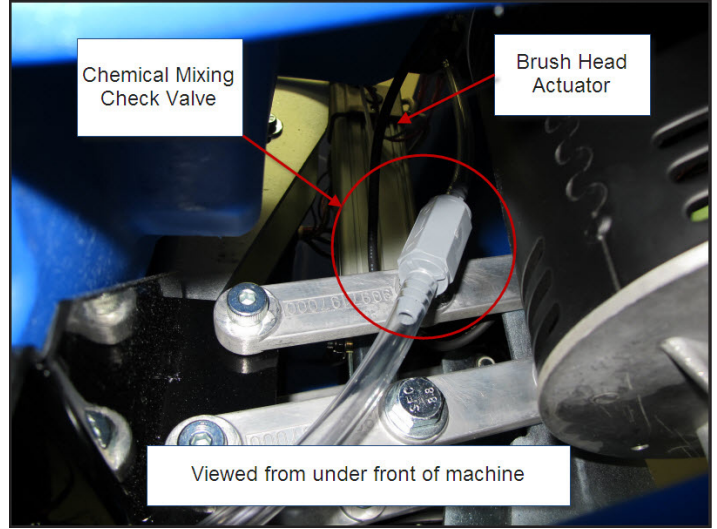
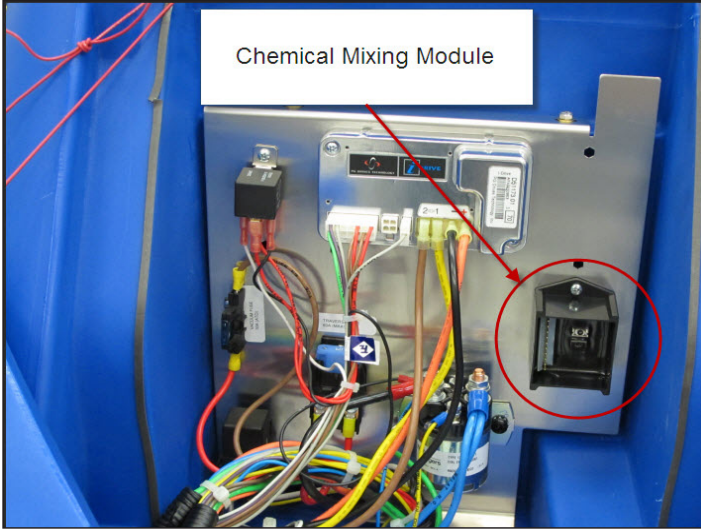

MAINTENANCE AND ADJUSTMENTS

SOLUTION FILTER CLEANING

1. Work near a floor drain for convenient clean up if possible
2. Turn key switch off.
3. Close the shut off valve (The valve is closed when the lever is NOT in line with the hose)

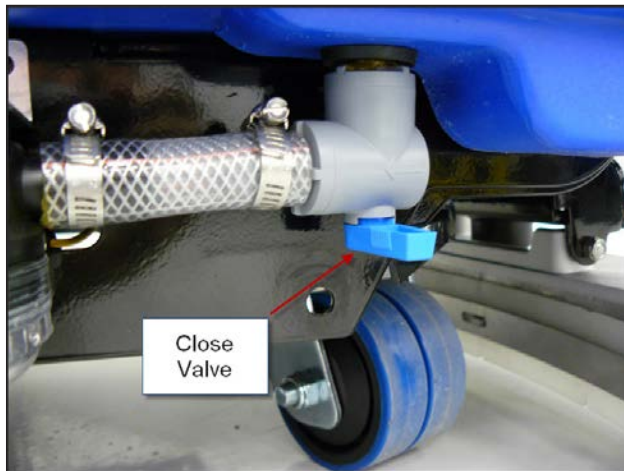

4. Unscrew the solution filter cover.

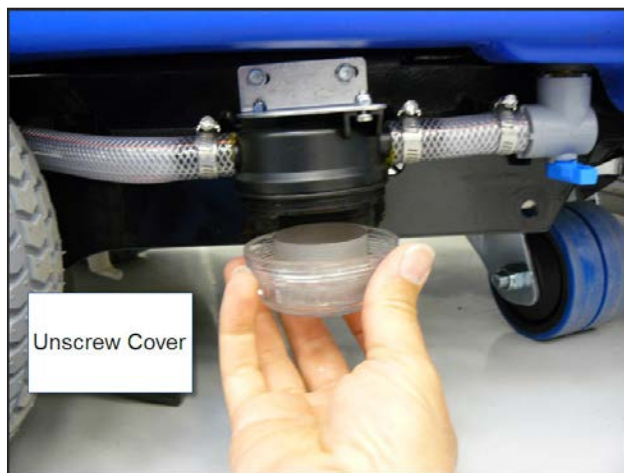

5. Remove and clean the screen.

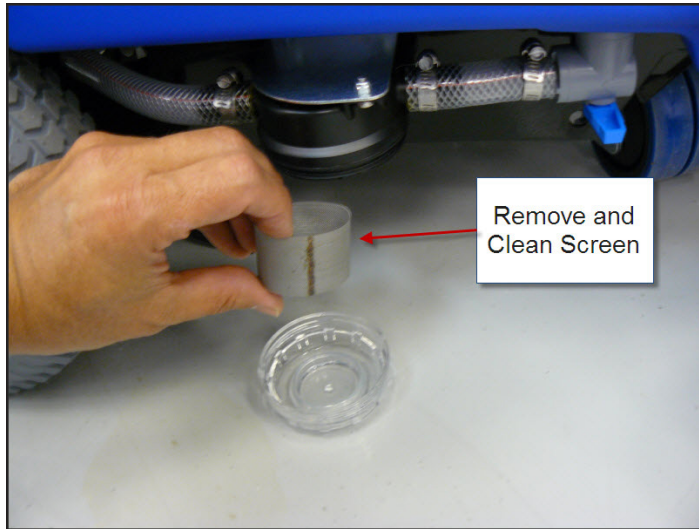

6. Reassemble in reverse order.
7. Open the shut off valve.

TROUBLESHOOTING

INSUFFICIENT SOLUTION FLOW

Possible Causes

- Restricted Solution Filter
- Debris in solution tank clogging fitting to shut off valve
- Pinched hose
- Restricted Solution Valve

SOLUTION LEAKS AFTER MACHINE IS SHUT OFF

Possible Causes

- Solution valve not sealing
- Hose or fitting leak before Solution valve

CHEMICAL IS NOT BEING ADDED TO THE SOLUTION (MACHINES WITH OPTIONAL CHEMICAL MIXING SYSTEM)

Possible Causes

- Chemical bottle empty
- Chemical hose blocked or leaking
- Check valve stuck closed
- Chemical pump
- Chemical soap module
- Wiring

REMOVAL AND INSTALLATION

SOLUTION VALVE

1. Work near a floor drain for convenient clean up if possible
2. Turn key switch on and lower the brush head by pushing the one touch control button.
3. Turn key switch off.
4. Close solution shut off valve
5. Remove solution mounting plate screws.
6. Remove hose clamps and hoses.
7. Disconnect electrical connector

SOLUTION TANK

1. Empty recovery and solution tanks.
2. Remove brush head.
3. Remove brush head actuator.
4. Remove recovery tank.
 - a.
 - b. Remove vacuum hose.
 - c. Remove drain hose.
 - d. Disconnect electrical connectors.
 - e. Remove steel plates over hinge pins.
 - f. Remove tether strap mounting screw
 - g. Remove tank.

5. Remove batteries.
6. Remove brush head actuator support
 - a. Remove two top bolts.

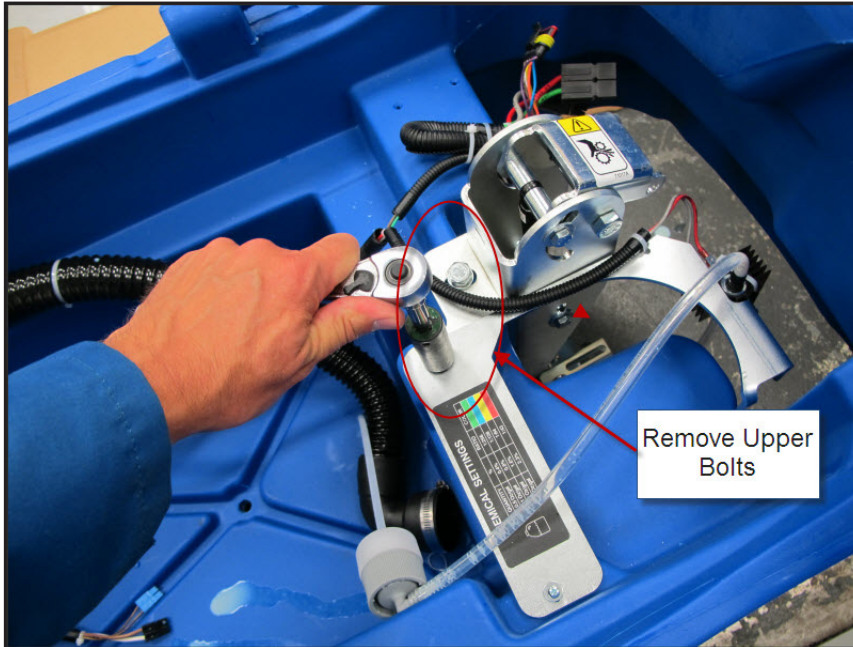

- b. Remove lower through bolt and nut.

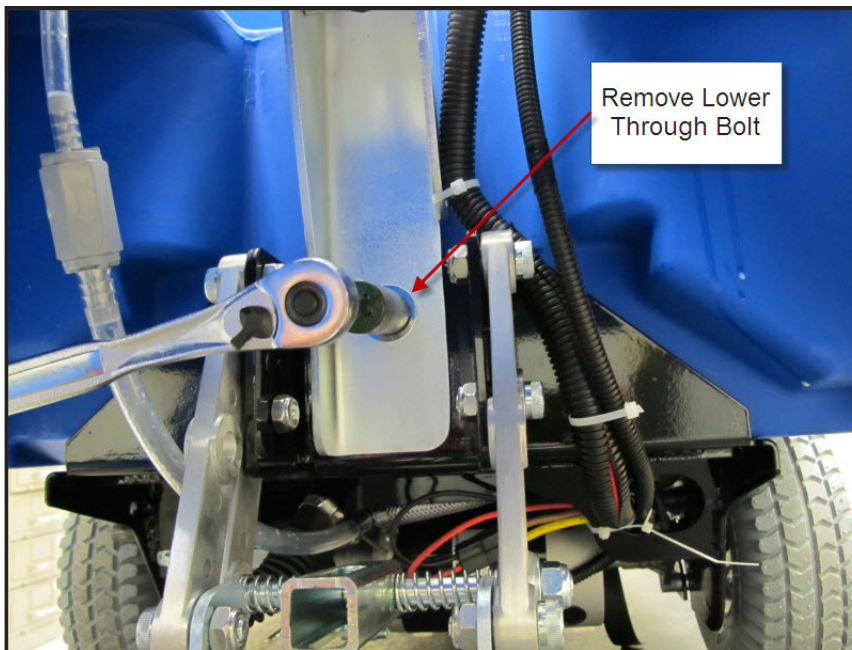

7. Remove handle assembly.
8. Disconnect wiring from electrical components on electrical panel.
9. Thread wiring out of solution tank.
10. Remove squeegee lift cable.
11. Remove solution tank shut off valve elbow from tank.
12. Remove battery compartment drain hose.
13. Remove 4 solution tank mounting bolts.

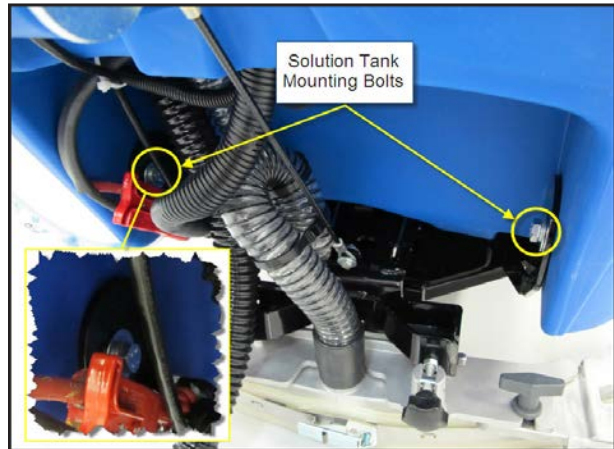
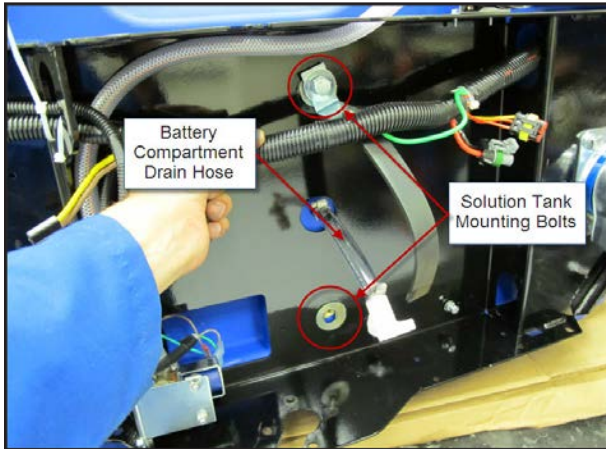

14. Separate tank from frame.

SPECIFICATIONS

- Solution Valve winding resistance – 54 ohms
- Solution Flow
- Chemical Pump winding resistance – 14 – 15 ohms

WHEEL SYSTEM, NON-TRACTION

FUNCTIONAL DESCRIPTION

A single caster wheel mounted to the back of the frame allows the machine to pivot easily. The wheel is attached with 4 bolts that are screwed into threaded holes in the frame.

COMPONENT LOCATIONS



WHEEL SYSTEM, TRACTION

FUNCTIONAL DESCRIPTION

A permanent magnet motor transaxle is used to propel the machine in both forward and reverse directions. The speed is variable in both directions and is adjusted by the Speed Control Potentiometer. The Drive Motor Controller operates the Transaxle Drive Motor by supplying electrical current according to input requests. It does not support diagnostic codes.

Powering up the Drive Motor Controller - When the key switch is turned on the main machine controller energizes the IDrive Relay by sending out a positive voltage to the relay winding at terminal 86. (The IDrive Relay is an "ISO" (International Standards Organization) relay. All ISO relays use terminals 85 and 86 for their electromagnetic winding. Terminals 30 and 87 are for the "load contacts" and are connected when there is current flowing through the winding causing the relay to be "energized". Terminals 30 and 87 are NOT connected when the relay is not energized. Sometimes ISO relays also have a terminal 87a. This is an additional load contact. Terminal 30 and 87a are connected when the relay is NOT energized and disconnected when the relay IS energized). Current flows through the winding and out terminal 85 to battery negative creating the magnetic field that pulls the relay contacts closed, connecting terminals 30 and 87. The Drive Motor Controller is supplied with direct battery positive and negative sources. It sends out a fused voltage from terminal 7 of the 14 way connector to terminal 30 of the IDrive Relay. When the relay is energized, the voltage is connected across terminals 30 to 87 and returned to the Drive Motor Controller at terminal 5 of the 14 way connector. This "turns on" the Drive Motor Controller.

Drive Motor Controller Inputs – To drive forward the operator presses either Forward Switch and rotates the Speed Control Potentiometer to achieve the desired speed. This is seen by the Drive Motor Controller as two inputs which are monitored by two "internal voltmeters". A combination Drive/Speed request input on terminal 1 of the 14 way connector and a Directional request input on terminal 12 of the 14 way connector. (See Figure 4 – Drive Inputs)

The Reverse Switch provides the "directional request input." Here is how it works. The Drive Motor Controller sends approximately 2.5v through an internal resistor out to the Reverse Switch. An "internal voltmeter" monitors the voltage. (See Figure 4 – Drive Inputs) When the Reverse Switch is open 2.5v is seen. This is interpreted as a "Forward Direction" request. When the Reverse Switch closes, it connects the voltage to battery negative through the Drive Motor Controller. This drops the voltage from 2.5v to nearly 0v. This is interpreted as a "Reverse Direction" request.

The Forward switch and the Speed Control Potentiometer work together to provide the combination Drive/Speed request input. The potentiometer provides a variable voltage signal from nearly 0volts to nearly 5 volts which is proportional to its position. The Forward Switch opens and closes to either block or allow the potentiometer signal to be seen by the controller. Here is how it works. The Drive Motor Controller sends out a regulated 5 volt supply out terminal 2 of the 14 way connector to the Speed Control Potentiometer gray wire. Current passes through the potentiometer resistive strip and returns to battery negative through the green wire into terminal 8 of the 14 way Driver Motor Controller connector. A "wiper" inside the potentiometer rides along the resistive strip as the knob is rotated and provides the signal going out to the Drive Motor Controller. When the wiper is near the 5 volt supply side, the signal going out on the blue wire will be close to 5 volts. When the wiper is near the battery negative side, the signal on the blue wire will be nearly 0volts. If the wiper is about in the middle, the signal on the wire will be about 2.5 volts, which is one half of the supply voltage. When the operator pushes on one of the Forward Switches, the switch closes allowing the signal voltage through to the Drive Motor Controller on the violet wire terminal 1 of the 14 way connector. The voltage seen by controller is interpreted as the "Drive/Speed" request input. Low voltage means "Go Slow". High voltage means "Go Fast". Don't be alarmed if you see about 2.2v on the violet wire coming out of the controller when the forward switch is open. This is a normal internal "diagnostic" voltage; once the forward switch closes, the Drive/Speed request input "covers up" this diagnostic voltage.

Drive Motor Control Circuit Forward Direction

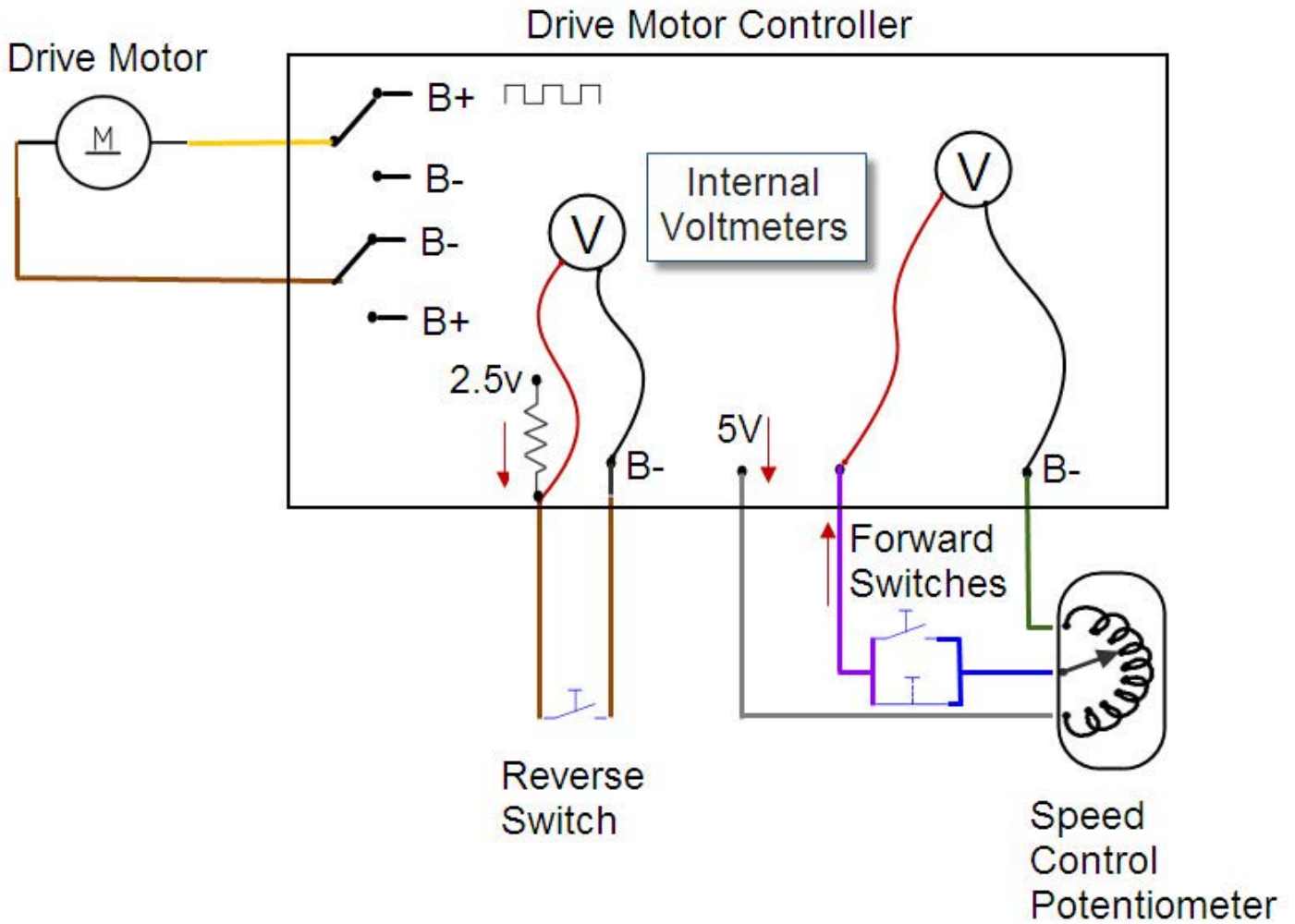
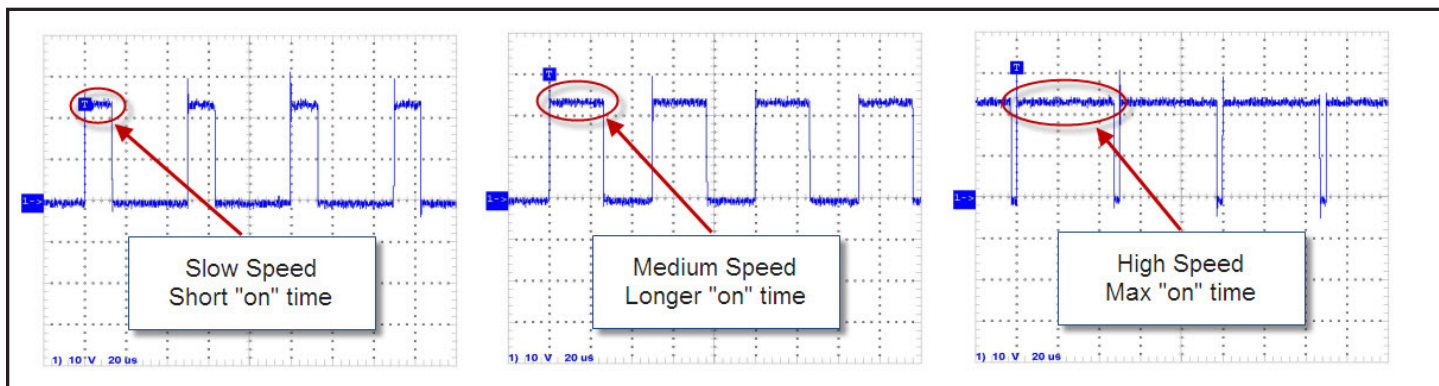

Figure 4 - Drive Inputs

Drive Motor Controller Outputs – The primary job of the Drive Motor Controller is to operate the electric transaxle drive motor. It does this by regulating current flow through the drive motor to control speed and by changing polarity to control direction. The secondary job is to notify the Main Machine Controller when the machine is moving. The Main Machine controller uses this information to start and stop the solution flow and scrub function.

To move the machine forward, the controller connects terminal 2 (brown wire) to battery negative AND connects terminal 1 to battery positive. To regulate the speed, the controller pulses the battery positive voltage out to terminal 1 (yellow wire) at a fixed frequency called a “duty cycle”. The greater the percentage of “on” time that the circuit is connected to battery positive, the faster the machine will go.



To move the machine in reverse terminal 1 (Yellow wire) is connected to ground and terminal 2 (brown wire) is pulsed to battery positive voltage. The speed in reverse is intentionally reduced.

When the Drive Motor Controller sends current to the drive motor, it also provides an output to the Main Machine Controller letting it know that it is OK to turn on the scrub function now because the machine is moving. Here is how it works. The Main Machine Controller sends a voltage through an internal resistor out terminal 4 of the 14 way connector gray wire to the Drive Motor Controller small 2 way connector with a single gray wire. The Main Machine Controller has an internal voltmeter that is monitoring this voltage. The voltage goes to a switch inside the Drive Motor Controller. When the machine is moving the internal switch is closed connecting the circuit to battery negative and dropping the voltage from approximately 17 volts to nearly 0 volts. This is interpreted by the Main Machine Controller as a “machine moving” signal. When the machine is not moving, the internal switch in the Drive Motor Controller is open causing the voltage to remain around 17 volts. This is interpreted by the Main Machine Controller as a “machine standing still” signal.

COMPONENT LOCATIONS

- Transaxle
- Drive Motor Controller
- Speed Control Potentiometer
- Forward Switches
- Reverse Switch
- IDrive Relay

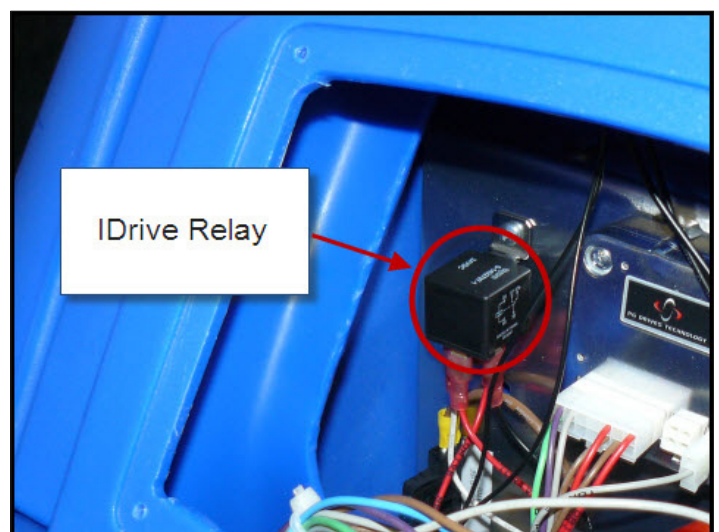
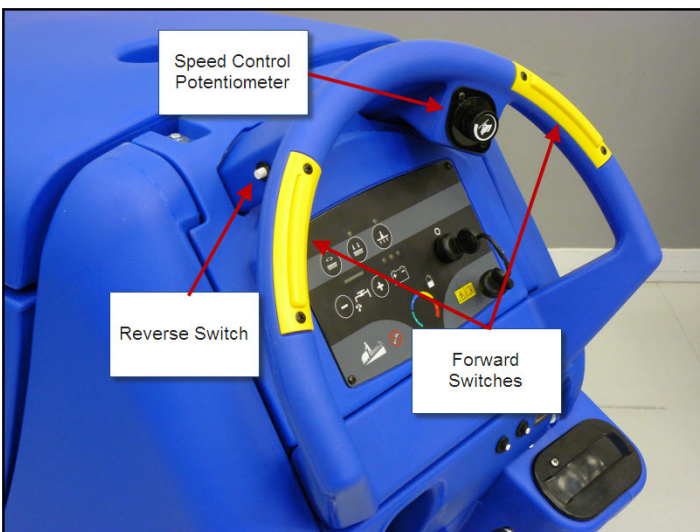
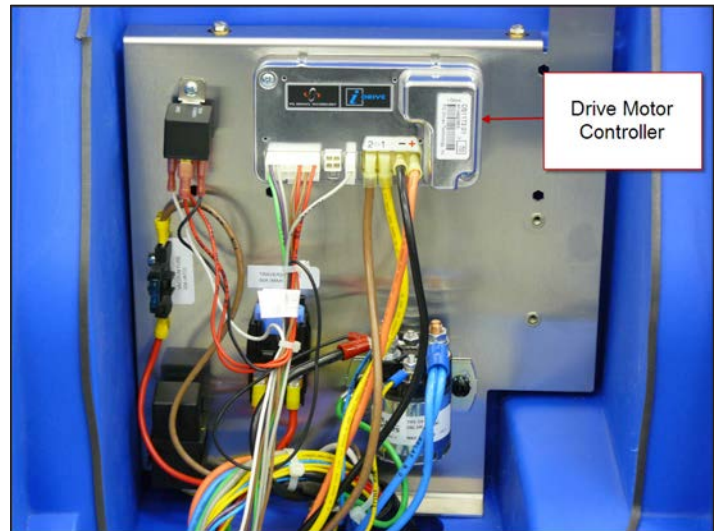
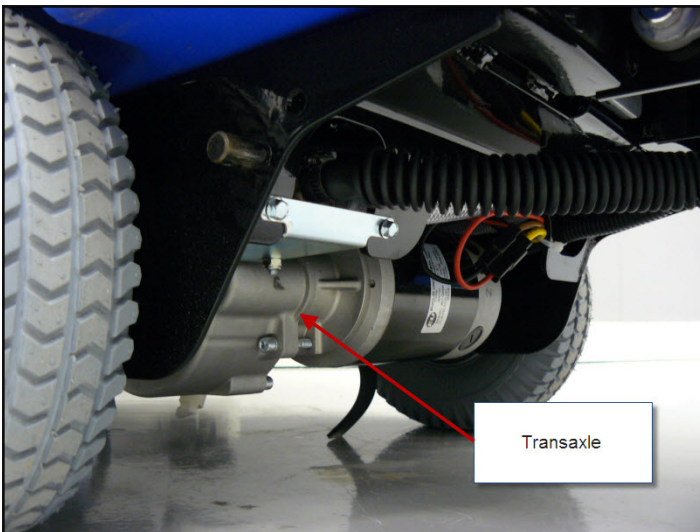

TROUBLESHOOTING

IDRIVE CONTROLLER (24VDC):

Note:

All voltage measurements should be in reference to the (B-) connection on the IDrive Controller.

1. Is there a minimum of 24Vdc at the (B+) and (B-) connections on the IDrive?

NO, check the "Traverse 60Amp Fuse" and / or wiring.

YES, Go to Step 2.

2. Is there a minimum of 24Vdc at Pin 7 of the 14 Pin connector of the IDrive?

NO, defective controller.

YES, Go to Step 3.

Note:

All measurements below should be taken with the "Key Switch" turned "ON".

3. Is there a minimum of 24Vdc at Pin 5 of the 14 Pin connector of the IDrive with the Key Switch turned "ON"?

NO, If not, check for voltage at the input of the IDrive Key Relay and / or the Key Switch.

There should be 24Vdc across the input of the IDrive Key Relay with the Key Switch turned "ON". If not, check the Key Switch and / or wiring.

YES, Go to Step 4.

4. Is there approximately 5.0Vdc between Pin 2 and Pin 8 of the 14 Pin connector of the IDrive?

NO, defective IDrive., Gray wire shorted to ground or Speed Control Potentiometer shorted.

YES, Go to Step 5.

5. Is there 0Vdc to 5.0Vdc between Pin 8 and Pin 1 of the 14 Pin connector of the IDrive with either "Forward" switch engaged?

NO, check the Forward Switches, Potentiometer and / or wiring.

YES, Go to Step 6.

6. Is there approximately 2.5Vdc on Pin 12 of the 14 Pin connector of the IDrive with the "Reverse" Button not depressed? If not, defective IDrive. This voltage should go to 0Vdc when the "Reverse" Button is depressed.

NO, defective Reverse Button and / or wiring.

YES, Go to Step 7.

7. Is there approximately 17 Vdc at Pin 2 of the 2 Pin connector of the IDrive with the "Brush Head" lowered to the floor and with the traverse not engaged? If not, check the Brush Solenoid, Control Panel

and / or wiring. This voltage should go to 0Vdc when the Forward traverse is selected.

NO, defective IDrive.

YES, Go to Step 8.

8. Is there 0Vdc to 24Vdc at the Motor Output on the IDrive when the Forward Traverse is engaged? Is there 0Vdc to 18Vdc at the Motor Output on the IDrive when the Reverse Traverse is engaged?

NO, defective IDrive.

REMOVAL AND INSTALLATION

TRANSAXLE

1. Empty solution and recovery tanks.
2. Remove the squeegee tool.
3. Remove the batteries.
4. Prepare a hoisting system on which the machine is to be laid on one side. (Protect the side from damage). With the help of an assistant lay the machine on one side.
5. Remove the wheel center bolts and remove the wheels.(Do not loose the square cut drive keys.)



6. Remove the transaxle to frame mounting bolts on both sides.



7. Disconnect the transaxle motor electrical connector.
8. Remove the transaxle by sliding it out of the frame slots.
9. Reassemble in reverse order.
 - a. Coat the ends of the axle shafts with anti-seize compound to prevent the wheel from corroding to the axle.

TRANSAXLE DRIVE MOTOR CARBON BRUSHES

1. Remove transaxle.
2. Remove Brush Cap.

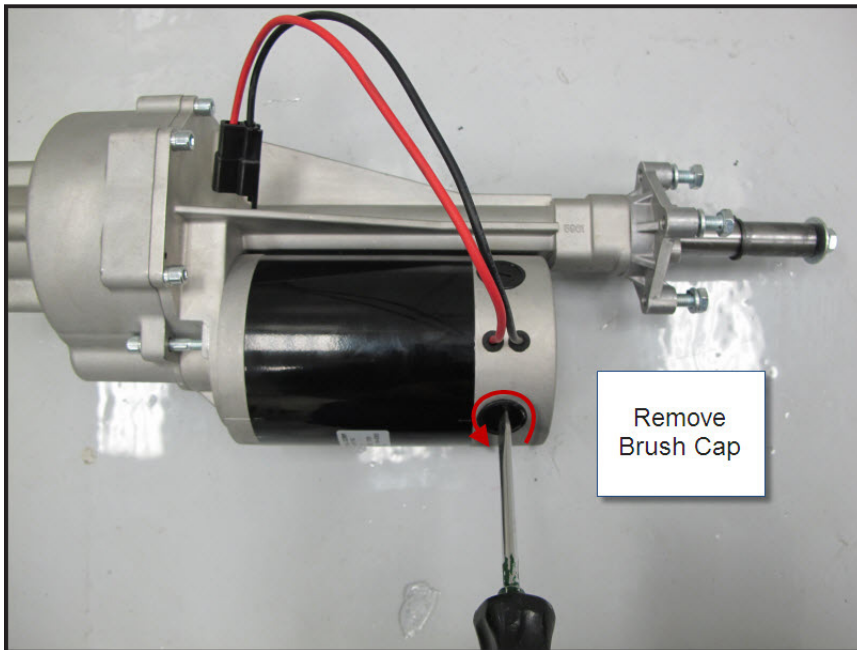

3. Remove Brush and Spring.

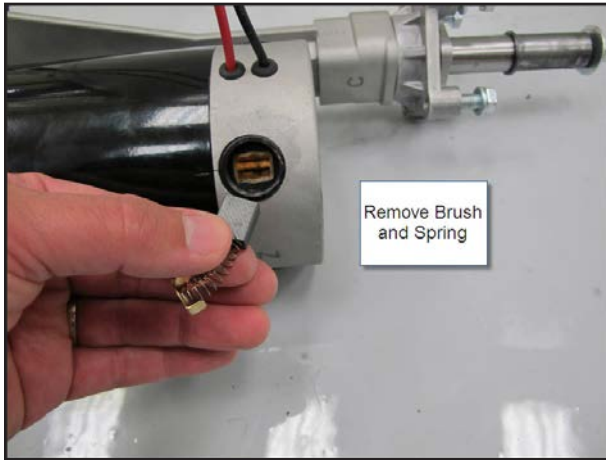

4. Install Brush and Spring.



5. Install Brush Cap.



6. Tighten cap with screwdriver
7. Repeat steps for all 4 carbon brushes.

SPECIFICATIONS

DRIVE MOTOR

Amp Draw Measurements

- No load (one wheel jacked up), jumped directly to battery- Approximately 2.5 amps
- Traversing on level floor with empty tanks driven by Drive Motor Controller at highest speed – Approximately 4 amps (Note: amp draw is higher when getting up to speed – approximately 10 – 12 amps.)

IDRIVE RELAY

Coil Resistance ~ 390 ohms