



## Electronic Service Manuals

This electronic document is provided as a service to our customers. We do not create the contents of the information contained in this document. Should you have detailed questions pertaining to the information contained in this document, you may contact Michco, or the manufacturer which provided the original information in this electronic deliverable. Michco's only part in this electronic deliverable was the electronic assembly process. By providing this manual on line we are not guaranteeing parts availability.

You may contact Michco through the following methods:

Phone (517) 484-9312 or (800) 331-3339

2011 N. High St. -- Lansing, Michigan -- 48906

Fax: (517) 484-9836

Email: [CustServe@Michco.com](mailto:CustServe@Michco.com)

Web site: [www.Michco.Com](http://www.Michco.Com)

Parts Web site: [www.FloorMachineParts.Com](http://www.FloorMachineParts.Com)

Order Parts on Line at:

**[www.FloorMachineParts.Com](http://www.FloorMachineParts.Com)**

Directly to Parts & Service:

By Email: **[Shop@Michco.com](mailto:Shop@Michco.com)**

By Fax: (517) 702-2041

By Voice: Use numbers above.

**Serving the Cleaning Industry Since 1922**

Notice: All copyrighted material remains property of original owners, all trademarks are property of respective owners. Manuals are subject to Manufacturer's reproduction limitations. Originals or reproductions were provided by manufacturers through a request. We make no warranty as to the correctness of information provided in this document and you assume all risk. By placing these manuals on line we are not declaring our corporation to be an manufacturer authorized dealer or provider, please check our web site for authorized manufacturers we represent.



**Operator's  
Manual**

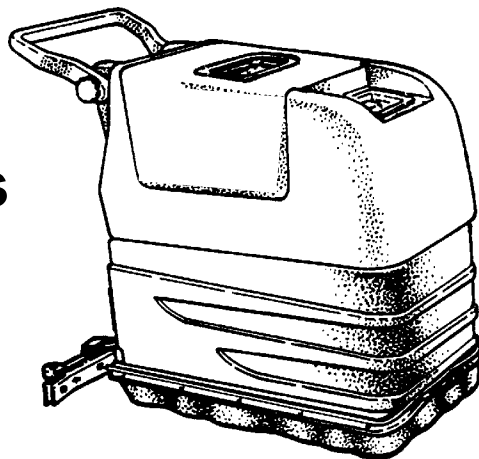

**Vision 17E  
115V**

### **READ THIS BOOK**

This book has important information for the use and safe operation of this machine. Failure to read this book prior to operating or attempting any service or maintenance procedure to your Clarke machine could result in injury to you or to other personnel; damage to the machine or to other property could occur as well. You must have training in the operation of this machine before using it. If your operator cannot read English, have this manual explained fully before attempting to operate this machine.

Si Ud. no pueden leer el Inglés, se hagan explicar este manual completamente antes de tratar el manejo o servicio de esta máquina.

All directions given in this book are as seen from the operator's position at the rear of the machine.

For new books write to: ALTO U.S. Inc., 2100 Highway 265, Springdale, Arkansas 72764.

## Table of Contents

Operator Safety Instructions .....	3
Introduction & Machine Specifications .....	5
Grounding Instructions 115V .....	6
Procedures for Transporting Machine .....	7
Machine Controls & Features .....	8
How to Prepare the Machine for Operation .....	11
How to Install the Squeegee .....	11
How to Install or Remove a Brush or Pad Driver .....	11
How to Operate the Machine .....	13
Filling the Solution Tank .....	13
Operating the Machine .....	13
Shutting Down the Machine .....	14
How to Clean a Very Dirty Floor .....	14
Maintenance .....	15
Procedures Before Work is Began .....	15
Procedures to Perform at the End of Work .....	16
Accessories .....	17
Machine Variables Vision 17E .....	17

## Section II - Parts and Service Manual



How to Correct Problems in the Machine .....	20
Vision 17E 115V Machine Assembly Drawing .....	22
Parts List .....	23
Non Traverse Assembly Drawing & Parts List .....	24
Brush Lift Drawing & Parts List .....	25
Main Frame Assembly Drawing .....	26
Parts List .....	27
115V Brush Motor Assembly Drawing & Parts List .....	28
115V Control Panel Assembly Drawing & Parts List .....	29
Squeegee Assembly Drawing & Parts List .....	30
Solution Tank Assembly Drawing & Parts List .....	31
Recovery Tank Assembly Drawing & Parts List .....	32
Vacuum Motor Drawing & Parts List .....	33
Brush Gear Box Assembly Drawing & Parts List .....	34
Brush Motor Drawing & Parts List .....	35
115V Electrical Schematic .....	36
115V Connection Diagram .....	37
Parking Brake Kit .....	38

# OPERATOR SAFETY INSTRUCTIONS

 **WARNING**

 **AVERTISSEMENT**

 **ADVERTENCIA**

-  **DANGER:** Failure to read and observe all **DANGER** statements could result in severe bodily injury or death. Read and observe all **DANGER** statements found in your Owner's Manual and on your machine.
-  **WARNING:** Failure to read and observe all **WARNING** statements could result in injury to you or to other personnel; property damage could occur as well. Read and observe all **WARNING** statements found in your Owner's Manual and on your machine.
-  **CAUTION:** Failure to read and observe all **CAUTION** statements could result in damage to the machine or to other property. Read and observe all **CAUTION** statements found in our Owner's Manual and on your machine.

 **DANGER:** Failure to read the Owner's Manual prior to operating or attempting any service or maintenance procedure to your Clarke machine could result in injury to you or to other personnel; damage to the machine or to other property could occur as well. You must have training in the operation of this machine before using it. If you or your operator(s) cannot read English, have this manual explained fully before attempting to operate this machine.

 **DANGER:** Operating a machine that is not completely or fully assembled could result in injury or property damage. Do not operate this machine until it is completely assembled. Inspect the machine carefully before operation.

 **DANGER:** Machines can cause an explosion when operated near flammable materials and vapors. Do not use this machine with or near fuels, grain dust, solvents, thinners, or other flammable materials. This machine is not suitable for picking up hazardous dust.











 **DANGER:** Using a machine with a damaged power cord could result in an electrocution. Do not use the machine if the power cord is damaged. Do not use the electrical cord to move the machine.

 **DANGER:** Electrocution could occur if maintenance and repairs are performed on a unit that is not disconnected from the power source. Disconnect the power supply before attempting any maintenance or service.

 **DANGER:** Electrocution or fire could occur if the machine is used on a power circuit that repeatedly trips or is undersized. Have a licensed electrician check the fuse, circuit breaker or power supply, and/or contact your local Clarke distributor for assistance.

 **WARNING:** Operating this machine from anywhere other than from the back of the machine could result in injury or damage. Operate this machine only from the rear.

 **WARNING:** This machine is heavy. Get assistance before attempting to transport or move it. Use two able persons to move the machine on a ramp or incline. Always move slowly. Do not turn the machine on a ramp. If operating machine on a gradient over 2%, do not stop, turn, or park. Read the "Procedures For Transporting" in this manual before transporting.

-  **WARNING:** Machines can topple over if guided over the edges of stairs or loading docks and cause injury or damage. Stop and leave this machine only on a level surface. When you stop the machine, put all switches into their "OFF" position.
-  **WARNING:** Maintenance and repairs performed by unauthorized personnel could result in damage or injury. Maintenance and repairs must be performed by authorized Clarke personnel only.
-  **WARNING:** Any alterations or modifications of this machine could result in damage to the machine or injury to the operator or other bystanders. Alterations or modifications not authorized by the manufacturer voids any and all warranties and liabilities.
-  **WARNING:** Electrical components of this machine can "short-out" if exposed to water or moisture. Keep the electrical components of the machine dry. Wipe the machine down after each use. For storage, keep the machine in a dry building.
-  **WARNING:** Operating a machine without observing all labels and instructional information could result in injury or damage. Read all machine labels before attempting to operate. Make sure all of the labels and instructional information are attached or fastened to the machine. Get replacement labels and decals from your Clarke distributor.
-  **WARNING:** Wet floor surfaces can be slippery. Water solutions or cleaning materials used with this type of machine can leave wet areas on the floor surface. These areas can cause a dangerous condition for the operator or other persons. Always put "Caution" signs around/near the area you are cleaning.
-  **WARNING:** Improper discharge of waste water may damage the environment and be illegal. The United States Environmental Protection Agency has established certain regulations regarding discharge of waste water. Also, city and state regulations regarding this discharge may be in effect in your area. Understand and follow the regulations in your area. Be aware of the environmental hazards of chemicals that you dispose.
-  **CAUTION:** Use of this machine to move other objects or to climb on could result in injury or damage. Do not use this machine as a step or furniture. Do not ride on this machine.
-  **CAUTION:** Your machine warranty will be voided if anything other than genuine Clarke parts are used on your machine. Always use Clarke parts for replacement.
-  **CAUTION:** Using a extension cord with your machine will result in a voltage drop and loss of power. Use of an extension cord is not recommended.

## Introduction & Machine Specifications

The Vision 17 automatic scrubber increases labor efficiency while providing superior cleaning. This unit dispenses the solution, scrubs the floor and then recovers the soiled solution - ***all in one pass.***

The Vision 17E can be adapted to clean any hard floor surface with a variety of floor cleaning accessories including a variety of bassine, steel, polypropylene, and nylon scrub brushes, pads and pad drivers. See the list of optional accessories on page 16 of this manual.

<b>Model 00370A</b>	<b>Vision 17 50/60Hz 115V</b>
<b>Power Source</b>	75' / 22.9 mm cord
<b>Sound Level (dba)</b>	75
<b>Charging Unit</b>	N/A
<b>Brush Drive Motor</b>	3/4 hp
<b>Brush Speed</b>	250 rpm
<b>Vacuum Motor</b>	3/4 hp, 2 stage
<b>Solution Tank</b>	8 gallon/30.28 L.
<b>Recovery Tank</b>	9 gallon/34.1 L.
<b>Speed Forward</b>	brush assist
<b>Squeegee</b>	24"/60.96 cm self-adjusting swing
<b>Scrubbing Path</b>	17"/43.2 cm width
<b>Dimensions</b>	36" x 19" x 33" 91.44 cm x 48.26 cm x 83.82 cm
<b>Shipping Weight</b>	188 lbs./ 85.28 kg.
<b>Base Weight</b>	148 lbs./ 67.13 kg.
<b>Warranty</b>	1 year

*Note: Additional machine variables are available. See accessories page for codes and description.*

## 120 VOLT, 50/60 CYCLE MACHINES GROUNDING INSTRUCTIONS

This product must be grounded. If it should malfunction or breakdown, grounding provides a path of least resistance for electric current to reduce the risk of electric shock. This product is equipped with a cord having an equipment-grounding conductor and grounding plug. The plug must be inserted into an appropriate outlet that is properly installed and grounded in accordance with all local codes and ordinances.

**⚠ WARNING:** Improper connection of the equipment-grounding conductor can result in a risk of electric shock. Check with a qualified electrician or service person if you are in doubt as to whether the outlet is properly grounded. Do not modify the plug provided with the product - if it will not fit the outlet, have a proper outlet installed by a qualified electrician.

This product is for use on a nominal 120 volt circuit and has a grounding attachment plug that looks like the plug illustrated in Fig. 1. Make sure that the product is connected to an outlet having the same configuration as the plug. No adaptor should be used with this product.

For maximum protection against electric shock, use a circuit that is protected by a ground fault circuit interrupter. The green (or green and yellow) conductor in the cord is the ground wire. Never connect this wire to any terminal other than the ground terminal.

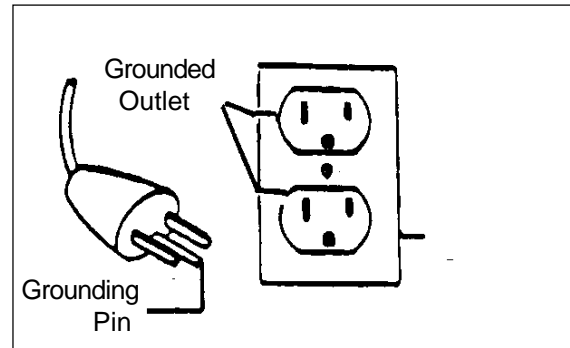

Figure 1

**⚠ WARNING:** To prevent possible electric shock, protect the machine from rain. Keep the machine in a dry building.

**⚠ WARNING:** To prevent possible electric shock, always use a 3-wire electrical system connected to the electrical ground. For maximum protection against electrical shock, use a circuit that is protected by a ground fault circuit interrupter. Consult your electrical contractor.

**⚠ WARNING:** Do not cut, remove or break the ground pin. If the outlet does not fit the plug, consult your electrical contractor.

**⚠ WARNING:** Have worn, cut, or damaged cords and plugs replaced by an authorized service person.

### EXTENSION CORDS

Use only an approved extension cord with three conductors, a plug with three terminals, and a connector body with three holes. The machine has a power cord with wire size 14 AWG (AWG means American Wire Gauge).

**⚠ WARNING:** If you use an extension cord, use an extension cord with minimum wire size 14 AWG. Do not use an extension cord longer than 50 feet. Do not join two extension cords.

---

## PROCEDURES FOR TRANSPORTING

### How to Put the Machine Into a Van or Truck

 **WARNING:** This machine is heavy. Get assistance before attempting to transport or move. Use two able persons to move the machine or a ramp or incline. Always move slowly. Do not turn the machine on a ramp. Do not stop and leave the machine on a ramp or incline.

To load the machine into a van or truck follow this procedure:

1. Remove the squeegee and the brush (see "How to Prepare Machine for Operation").
2. Obtain a loading ramp that is at least 8' long and secure enough to support the weight of the machine.
3. Make sure the ramp is clean and dry.
4. Put the ramp into position and secure.
5. Align the machine on a level surface in front of the ramp.
6. With the assistance of another person, pull the machine up the ramp slowly.
7. Securely fasten the machine to the vehicle.

### How to Remove a Machine From a Van or Truck

To remove the machine from a van or truck, follow this procedure:

1. Make sure that there are no obstructions in the area.
2. Obtain an unloading ramp that is at least 8' long and strong enough to support the weight of the machine.
3. Make sure the ramp is clean and dry.
4. Put the ramp into position and secure.
5. Untie the machine.
6. With the aid of another person, carefully guide the machine out of the truck or van onto the unloading ramp slowly.
7. When guiding the machine on the unloading ramp, position yourself to maintain a slow speed. Never stand below machine on ramp.

## MACHINE CONTROLS and FEATURES

### Brush Switch. See Figure 2.

The brush switch is to the left of the vacuum switch on the control panel. To start the brush motor, press the top of the switch. To stop the brush motor, press the bottom of the switch.

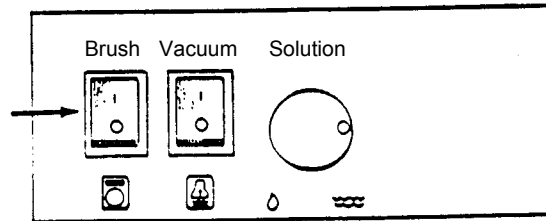

Figure #2

### Vacuum Switch. See Figure 3.

The vacuum switch is to the left of the solution control knob. To start the vacuum motor, press the top of the switch. To stop the vacuum motor, press the bottom of the switch.

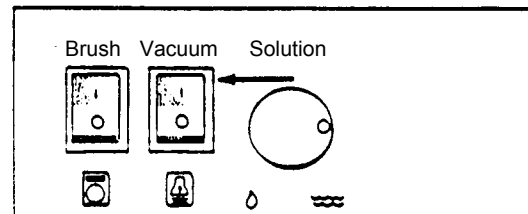

Figure #3

### Solution Control Knob. See Figure 4.

The solution control knob is in the middle of the control panel. For more solution, turn the knob to the right. For less solution, turn the knob to the left.

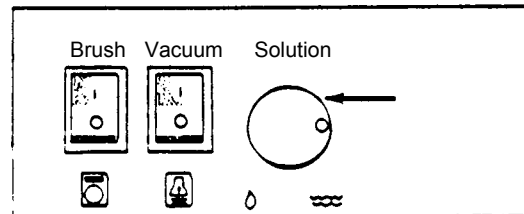

Figure #4

### Circuit Breaker.

Electric Model

Brush Motor Circuit breaker only.  
(located on control panel)

## MACHINE CONTROLS and FEATURES (cont'd)

### Brush Control Pedal. See Figure 5.

The brush control pedal is at the back of the machine in the lower right corner. Use your foot to operate the pedal. To lower the brush, push the pedal down and to the left, releasing it from the locked position. To raise the brush, push the pedal down and to the right engaging the lock.

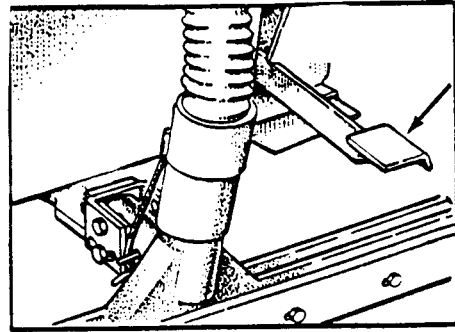

Figure #5

### Brush Tilt Control.

The brush tilt control is on the left side by the motor. To access motor, turn off the key, remove the squeegee cable, and undo tank clamps. To adjust how the machine pulls, loosen the screw. Tilt the motor forward to decrease the brush-assist traverse. Tilt the motor back to increase the brush-assist traverse. After adjustment retighten the screw.

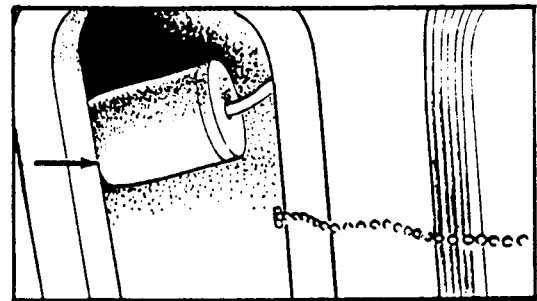

Figure #6

### The Float Shut-Off. See Figure 6.

The float shut-off is in the back of the recovery tank. When the liquid raises the float, the float switch will automatically turn the vacuum motor off. To continue working you must drain the recovery tank.

### The Squeegee Handle. See Figure 7.

The squeegee handle is at the back of the machine in the middle. To lower the squeegee, pull the handle to the right and lower. To raise the squeegee, lift the handle up and push to the left.

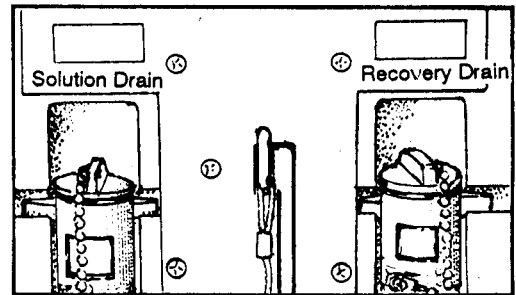

Figure #7

## MACHINE CONTROLS and FEATURES (cont'd)

**Machine Control Handle.** See Figure 8.

The machine control handle (a) is located on the back side of the machine. The handle is adjustable for operator comfort and ease. The handle adjustment knobs are located at the base (b) of the handle.

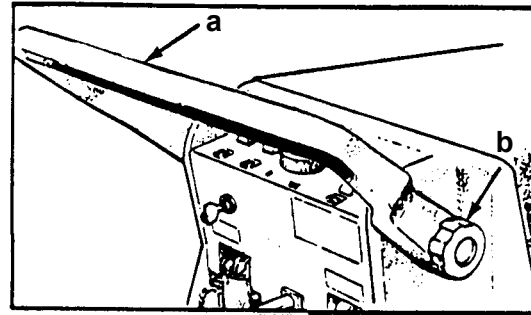

Figure #8

**Machine Lift Handle.** See Figure 9.

The machine lift handle is located on the front of the machine. Use this handle to lift the machine when changing the brush. See the section in this Owner's Manual "Installing or Removing a Brush or Pad Driver".

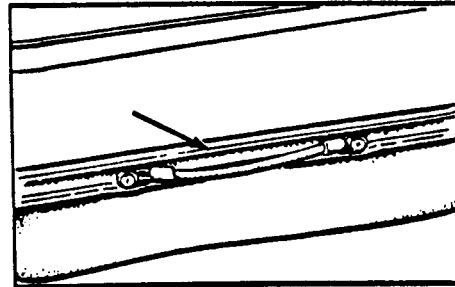

Figure #9

**Machine Support Leg.** See Figure 10.

The machine support leg is located in the front of the machine under the bumper skirt. Put the machine support leg down when installing or removing a brush or pad driver.

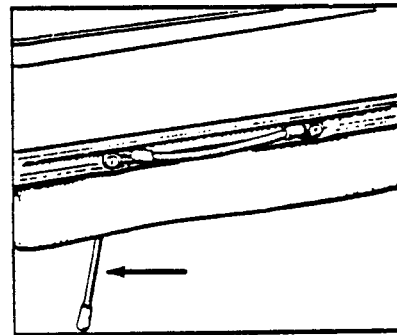

Figure #10

## How to Install the Squeegee

To install the squeegee, follow this procedure:

1. Attach the squeegee cable to the squeegee lift arm (a) and squeegee bracket (b). See Figure #11.
2. Raise the squeegee lift arm.
3. Place the squeegee onto the squeegee bracket.
4. Push the hair pin through the holes on the squeegee bracket.
5. Attach the squeegee hose to the hose connection on top of squeegee. See figure #12.

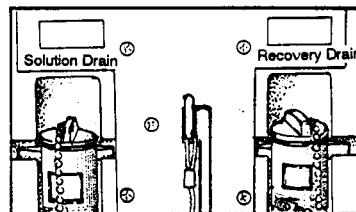

Figure #11a

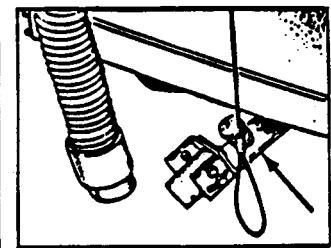

Figure #11b

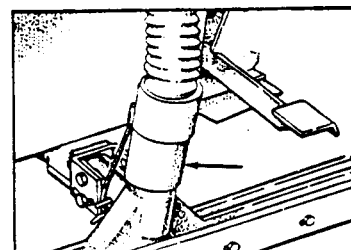

Figure #12

# HOW TO PREPARE THE MACHINE FOR OPERATION

## How to Install the Squeegee Connection

The proper method for assembling the squeegee connection is as follows::

1. Unscrew the nut completely.
2. Slide the nut and gasket onto the tube. (Figure 1a)
3. Slide the elbow onto the tube and make sure the gasket is secured into the elbow. (Figure 2a)
4. As you hold the elbow tight onto the tube, tighten the nut over the gasket and the elbow. (Figure 3a)

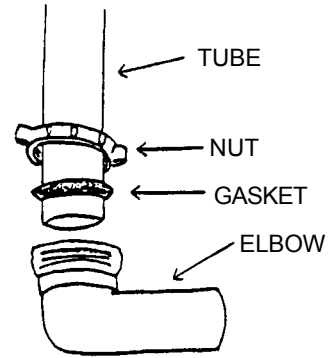

Figure 1a

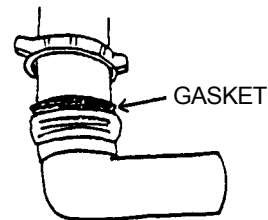

Figure 2a

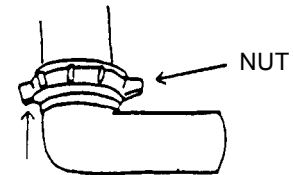

Figure 3a

## How to Install or Remove a Brush or Pad Driver

To install or remove a brush or a pad driver, follow this procedure:

**NOTE: The brush may spin off the machine if the brush switch is turned ON or OFF while the brush is in the raised position.**

1. If machine is an electric model disconnect the power supply.
2. Put the squeegee down to the floor by pulling the squeegee handle to the right and down.
3. Remove the cotter pin from the squeegee bracket and remove the squeegee. See Figure #12.
4. Slide the squeegee bracket either right or left all the way under the machine skirt. See Figure #11.
5. While lifting the machine up with the machine lift handle (a), lower the support leg and position like a kickstand (b). See Figure 13

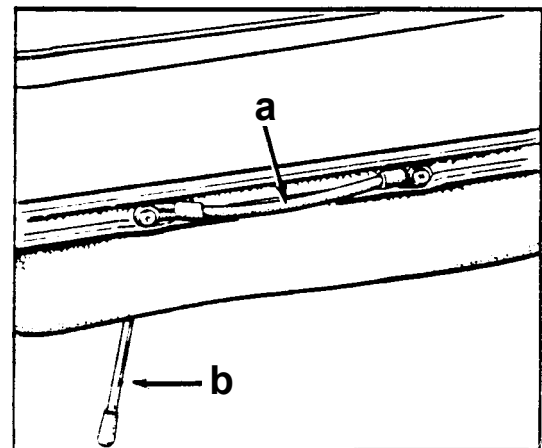

Figure 13

---

## HOW TO PREPARE THE MACHINE FOR OPERATION (cont'd)

6. To install the brush or pad driver, align the lugs on the locking plate of the pad driver or brush with the adapter plate.
7. Turn the brush or pad driver clockwise to lock it into position.
8. To remove a brush or pad driver, turn the pad driver or brush to the left and remove.
9. Lift up the machine with the lift handle and return the support leg to its normal position.



**CAUTION:**

**Leaving the brush motor switch in its "DOWN" position when the machine is not in use can damage the brush or pad driver. Always leave the brush motor in the "UP" position while not in use.**

## HOW TO OPERATE THE MACHINE

### Filling the Solution Tank

To fill the solution tank, follow this procedure:

1. Lift the solution tank lid out of the opening. Allow the lid to hang to the front of the machine. See figure # 14.
2. With a hose or bucket fill the solution tank with clean water to within one inch of the bottom of the opening.
3. Add a cleaning chemical to the water. For the correct amount, follow the manufacturer's directions shown on the chemical container.
4. Put the lid back onto the solution tank opening.

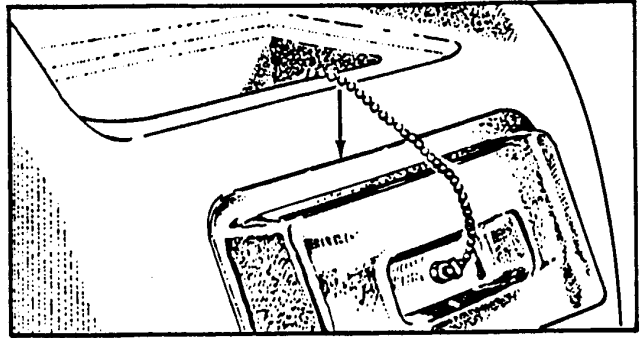

Figure #14

### Operating the Machine

1. Put water and a cleaning chemical into the solution tank.
2. Lower the squeegee. To lower the squeegee, pull the squeegee handle to the right and lower.
3. Lower the brush. To lower the brush, step on the brush control lever (figure #15) and push down slightly, then move the lever to the left and allow it to come up.

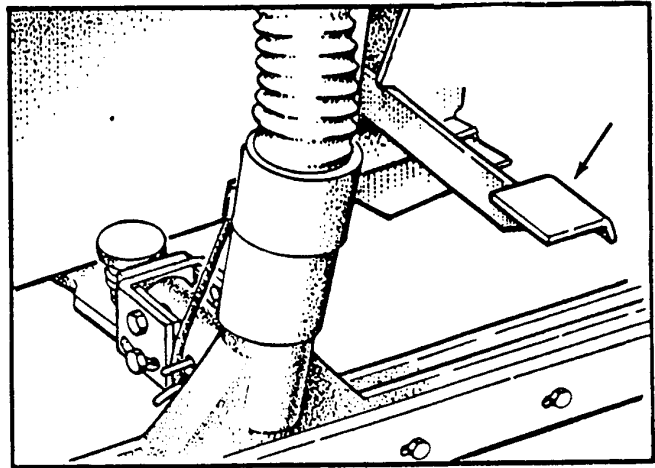

Figure #15

**NOTE: Keep the machine moving when the brush is rotating on the floor.**

4. Press the top of the brush switch to activate the brush motor.
5. Press vacuum switch to activate vacuum motor.
6. Activate the flow of solution by turning the solution control knob to the right. To make sure you have an even flow of solution, turn the knob to the right as the amount of solution in the tank decreases.
7. Move the machine forward in a straight and steady direction. If machine is a traverse model, select a speed and then press on the traverse handle switch to activate the traverse.

---

## HOW TO OPERATE THE MACHINE (cont'd)

8. To turn the machine, push the rear of the machine to the side opposite the direction you want to turn. It is **NOT RECOMMENDED** that you move the machine backward during a cleaning operation.
9. When you make more passes across the floor, let the brush clean approximately 2 inches of the area already cleaned by the last pass.

**NOTE: During most cleaning procedures, apply and remove the solution in one operation.**

### Shutting Down the Machine

To shut down the machine, follow this procedure:

1. Turn solution flow "Off" by turning the knob all the way to the left (counter clockwise).
2. Lift the squeegee up by lifting up on the handle and locking it into the "UP" position.
3. Press the bottom of the vacuum switch to turn the vacuum "Off".
4. Press the bottom of the brush switch to turn "off" the brush motor.
5. Raise the brush up by pushing down on the brush lift lever with your foot sliding the lever to the right.

**NOTE: The brush may spin off the drive adapter if the brush switch is turned ON or OFF while the brush is in the raised position.**

### How to Clean a Very Dirty Floor

To clean a very dirty floor, follow this procedure:

1. Put water and cleaning chemical into the solution tank.
2. Activate the flow of solution by turning the solution control knob to the right and move the machine in a straight and steady direction. You are not removing the solution in this pass.
3. After the solution has set on the floor long enough to start cleaning, repeat the pass with the squeegee in the lowered position.
4. If the floor remains dirty, repeat the passes following the steps outlined in "Operating the Machine".

## MAINTENANCE

- ⚠ DANGER:** Maintenance and repairs performed by unauthorized personnel could result in damage or injury. Maintenance and repairs must be done by authorized Clarke personnel only.
- ⚠ DANGER:** Operating a machine that is not completely or fully assembled could result in injury or property damage. Do not operate this machine until it is completely assembled. Inspect the machine carefully before operation. Keep all fasteners tight.
- ⚠ DANGER:** Electrocution could occur if maintenance and repairs are performed on a unit that is not properly disconnected from the power source. Always disconnect the power supply before attempting any maintenance or service.
- ⚠ WARNING:** Attempting maintenance and or repairs to this machine before emptying the solution or recovery tank could result in machine or property damage.

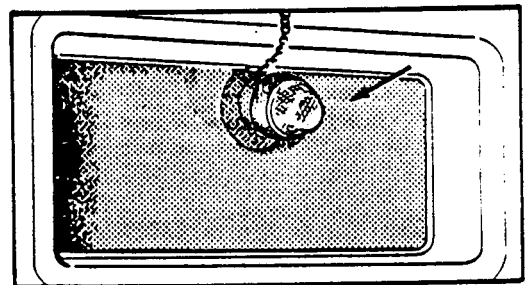

Figure #16

### Procedures Before Work is Begun

Keep the machine clean. It will need fewer repairs and have a longer life.

1. Check power cord and plug for frayed or damaged wires or missing terminal or plug.
2. Make sure the recovery tank cover is in place.
3. Check the solution tank screen and clean if necessary. See Figure #16.
4. Make sure the vacuum screen is clean and in position in the front of the recovery tank. See Figure #17.
5. Make sure the solution and recovery drain hoses are in position on the back of the machine. See figure #18. Secure the hose drain plugs.

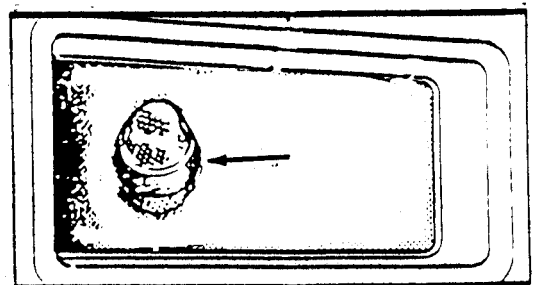

Figure #17

## MAINTENANCE (cont'd)

6. Make sure the bumper skirt is in position. The bumper skirt prevents solution from flowing from under the frame.
7. Make sure the brush is in position.
8. Make sure the vacuum hose is installed and on the squeegee. See Figure #19.
9. Connect the power cord to the electrical outlet.

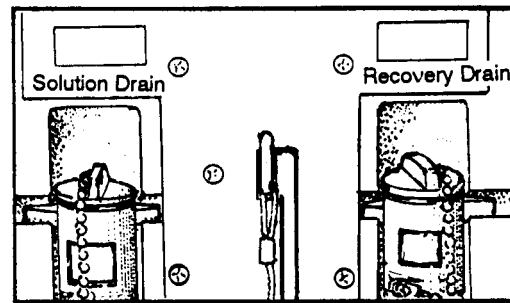

Figure #18

### Procedures to be Performed at the End of Work

1. Disconnect from power.
2. Drain and flush the tanks. To drain the recovery and solution tanks, follow this procedure:
  1. Remove the drain hose from the fitting on the back of the machine.
  2. Put the end of the hose over a drain or bucket.
  3. Run clean water into the solution and recovery tanks to flush the tanks.
  4. Put the end of both hoses over a drain or bucket.
3. Leave the tanks and the drain hoses open to dry in the air.
4. Check and clean the squeegee blade. Use a soft cloth to clean the squeegee blade. If the squeegee blade is damaged or worn, turn or replace the blade.
5. Check and clean the vacuum gaskets, the vac screen filter and the solution screen filter. Remove and clean with a vinegar-water solution or warm soapy water. Rinse the parts in clean water.
6. Use a clean cloth and wipe the surface of the machine.
7. Remove the brush or pad driver. Rinse clean and allow to dry. Discard the pad if necessary.
8. Store the machine and accessories in a dry building.

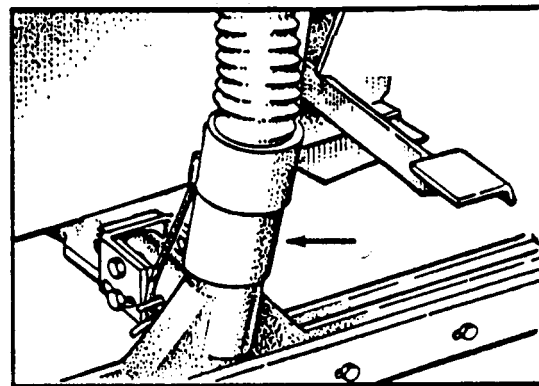

Figure #19

**CLARKE TECHNOLOGY**  
**Vision 17E 115V**  
**Machine Variables 6/02**

<b>Electric - 115V</b>	Variable Code		
	00371A	Breakdown:	
		00370A	Vision 17E Std. Base Machine 115V
		51436B	Brush, Polypropylene
	00372A	Breakdown:	
		00370A	Vision 17E Std. Base Machine 115V
		53126B	Pad Driver

Accessories:

Part No.	Description
51436B	Brush, Polypropylene
53126B	Pad Driver
50527A	Base
56927A	Retainer
50477A	Clutch Plate for Pad/Brush
962819	Clutch Plate Screws
51437B	Nylon Scrub Brush, .028 Dia. Bristles
51439B	Grit Scrub Brush Assembly
682408	Hose Connector - connects 1½" diameter hose to machine
674114	10' x 1½" red spiral lock deluxe hose
639804	1½" double curved aluminum wand
638828	Aluminum 14" squeegee pick up tool
680724	Replacement blades for 638828 (Req. 2 set)
638856	Aluminum combination scrubbing brush & squeegee pick-up tool
51469B	Nylon Scrub Brush, .016 Dia. Bristles
51481A	Grit-Lite◆
10773K	Parking Brake Kit
18800Au	Squeegee Asm.

**NOTE:**◆ indicates a change has taken place since last publication of this manual

**PADS BY CASE**

<table border="0" style="width: 100%;"> <tr> <td style="padding: 2px;">Color</td> <td style="padding: 2px;">Vision 17</td> </tr> <tr> <td style="padding: 2px;">Yellow</td> <td style="padding: 2px;">979169</td> </tr> <tr> <td style="padding: 2px;">White</td> <td style="padding: 2px;">976052</td> </tr> <tr> <td style="padding: 2px;">Red</td> <td style="padding: 2px;">976053</td> </tr> <tr> <td style="padding: 2px;">Blue</td> <td style="padding: 2px;">976054</td> </tr> </table>	Color	Vision 17	Yellow	979169	White	976052	Red	976053	Blue	976054	<table border="0" style="width: 100%;"> <tr> <td style="padding: 2px;">Color</td> <td style="padding: 2px;">Vision 17</td> </tr> <tr> <td style="padding: 2px;">Green</td> <td style="padding: 2px;">976157</td> </tr> <tr> <td style="padding: 2px;">Brown</td> <td style="padding: 2px;">976055</td> </tr> <tr> <td style="padding: 2px;">Black</td> <td style="padding: 2px;">976158</td> </tr> </table>	Color	Vision 17	Green	976157	Brown	976055	Black	976158
Color	Vision 17																		
Yellow	979169																		
White	976052																		
Red	976053																		
Blue	976054																		
Color	Vision 17																		
Green	976157																		
Brown	976055																		
Black	976158																		





## **Vision 17E 115V**

### **Section II Parts and Service Manual**

(78452B)

## HOW TO CORRECT PROBLEMS IN THE MACHINE

<b>PROBLEM</b>	<b>CAUSE</b>	<b>ACTION</b>
<b>There isn't any solution flow.</b>	<p>The solution tank is empty.                      The solution knob is turned too far to the left.                      There is an obstruction in the hose or filter.                      The solution valve or linkage is damaged.</p>	<p>Fill the solution tank.                      Turn the solution knob to the right.                      Remove the obstruction from hose or filter.                      Repair or replace the valve or the linkage.</p>
<b>The solution flow does not stop.</b>	<p>The solution valve is open.                      The solution valve or linkage is damaged.                      The solution valve is dirty.                      There is a damaged seat and washer in the solution valve.                      The valve stem is dirty.</p>	<p>Close the solution valve.                      Repair or replace the valve or the linkage.                      Clean the solution valve.                        Replace the valve.                      Clean and lubricate the valve stem.</p>
<b>The machine does not remove any water from the floor.</b>	<p>The squeegee is up.                      The vacuum motor is not running.                      The vacuum motor switch is defective.</p> <p>The recovery tank is full.                      The vacuum shut-off float circuit is open.                      The vacuum filter screen is dirty.                      There is an obstruction in the vacuum tube.                      There is an obstruction or damage in the squeegee, vacuum hose or standpipe.                      The squeegee hose is disconnected.</p>	<p>Lower the squeegee.                      Put the switch in the "ON" position.                      Have an authorized Clarke person make repairs.                      Drain the tank.                      Recovery tank is full. Empty the tank.                      Clean or replace the filter screen.                      Remove the obstruction.                      Remove the obstruction or repair the damage.                      Connect the hose.</p>
<b>The machine does not remove all the water from the floor.</b>	<p>The squeegee blades are damaged, worn, or incorrectly installed.                      There is an obstruction or damage in the squeegee, vacuum hose or standpipe.                      The filter screen is dirty.                      The gasket on the cover of the recovery tank are damaged.                      Defective vacuum motor.</p>	<p>Turn or replace the squeegee blade.                      Correctly install the squeegee blade.                      Remove the obstruction or repair the damage.                      Clean or replace the filter screen.                      Replace the gasket.                        Have an authorized Clarke person make repairs.</p>
<b>The cleaning is not even.</b>	<p>The scrub brush or pad are worn.                      There is damage to the brush assembly casters or to the solution valve.                      The motor is not running.</p>	<p>Replace the scrub brush or pad.                      Have an authorized service person make the repairs.                      Repair the wiring, replace the switch,                      Service the motor, circuit breaker and the contractor.</p>



CLARKE TECHNOLOGY  
Vision17 E 115V  
Model#00370A 115V Machine Assembly 2/01

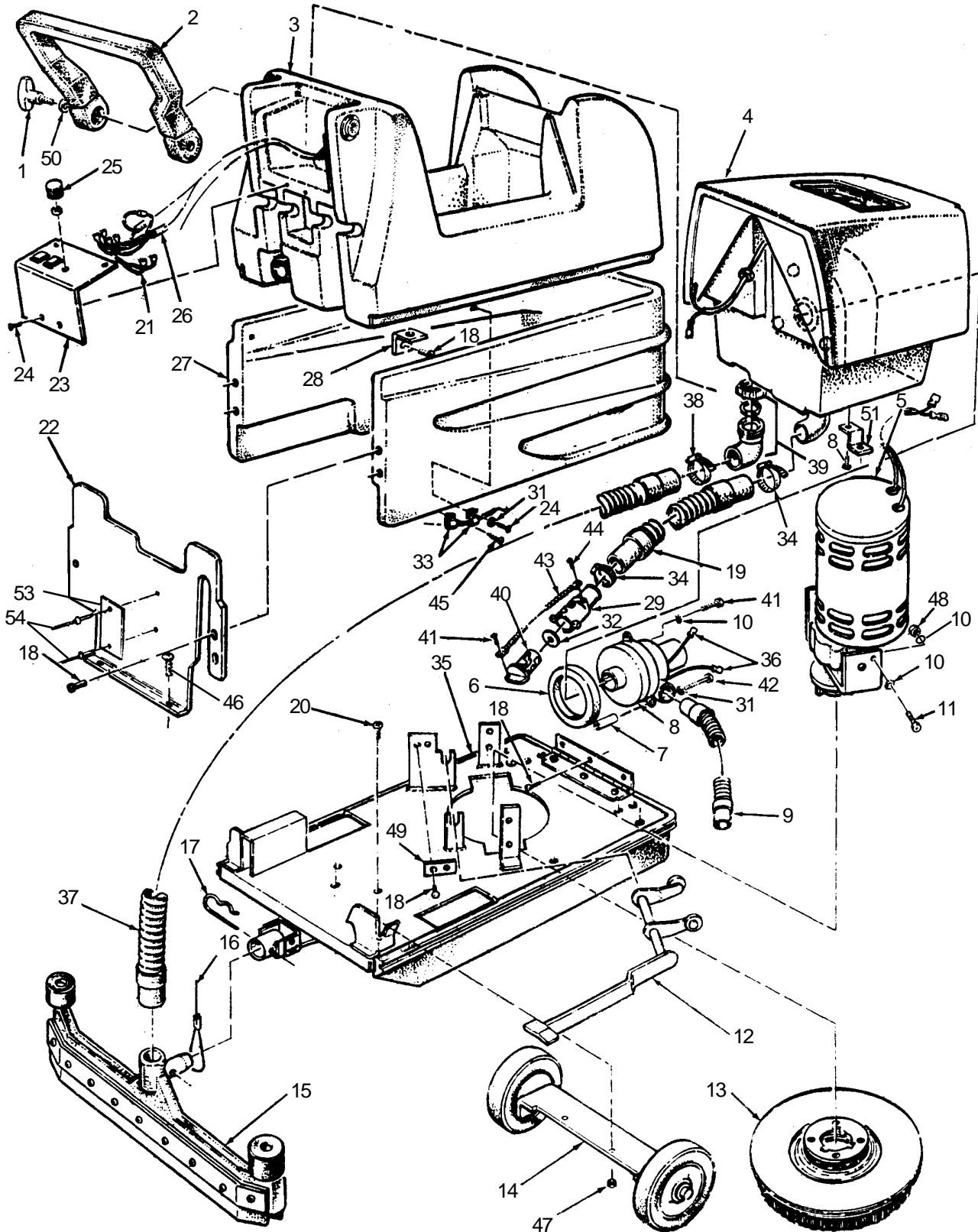

**CLARKE TECHNOLOGY**  
**Vision 17 E 115V**  
**Models #00370A 115V Machine Assembly Parts List 2/01**

Ref	Part No.	Description	Qty
1	55531A	Knob, Handle	2
2	34804A	Handle, Control	1
3	Page 29	ASM, Solution Tank	1
4	Page 30	ASM, Recovery Tank	1
5	Page 26	ASM Brush, 115V Motor	1
	Page 32	Gear Box Parts List	
	Page 33	Brush Motor Parts List	
6	643418	Gasket Vacuum Motor	1
7	58534A	Spacers	3
8	44906A	Motor, 115V Vacuum	1
	Page 31	Vacuum Motor Parts List	
9	30448A	Hose, Exhaust, Vacuum	1
10	980603	Washer, Shake Proof	3
11	962798	Screw 10-24 x ½	1
12	Page 23	ASM, Brush Lift	1
13	Page 15	Pad or Brush Driver	1
14	Page 22	ASM, Non Traverse Electric	1
15	Page 28	ASM, Squeegee	1
16	61664A	Cable, Squeegee	1
17	66515A	Pin, Locking	1
18	85395A	Screw, ¼ - 20 S.S..	8
19	30415A	Hose, Drain	1
20	84238A	Screw 5/16 Flat	2
21	49686A	Harness, Brush	1
22	37108A	Panel, Rear	1
23	Page 27	ASM, Panel Control 115V	1
24	84237A	Screw, 10 - 32 X ½ S.S.	4
25	55502A	Knob, Solution Control	1
26	49688A	Harness, Vacuum Motor	1
27	38952B	Support Tank	1
28	61244A	Bracket Tank	5
29	839401	Valve, Drain	1
31	87026A	Washer	7
32	833407	Gasket	1
33	832102	Clamp, Solution Cable	2
34	832002	Clamp, Plastic	2
35	Page 24/25	ASM, Main Frame	1
36	47905A	Terminal, Male	2
37	30407B	Hose, Squeegee	1
38	752020	Clamp, Hose	1
39	53630A	Elbow, Recovery	1
40	833901	Drain, Handle	1
41	962987	Screw, 10-24 x 3/8	2
42	962950	Screw ¼ - 20 x 3"	3
43	52206A	Chain	1
44	962943	Screw 8-18 x ½	1
45	962981	Screw, 10-00 x 5/8	1
46	962109	Screw 10-24	2
47	920110	Nut 5/16 -18 ESNA	2
48	920296	Nut 10-24	1
49	66939A	Retainer	Ref
50	980413	Washer	2
51	63040A	Bracket, Recovery	2
52	839204	Trim, Frame	1
53	77261A	Plate, Warning	1
54	83010A	Rivet	2
NI	58901A	Wire Tie	1
NI	699202	Wire Tie	2
NI	77049A	Label, Squeegee Lift	1
NI	77050A	Label, Brush Lift	1
NI	77053A	Tag, Hang Instruction	1
NI	77077A	Plate, Warning (Head)	1

**CLARKE TECHNOLOGY**  
**Vision 17E 115V**  
**ASM, Non Traverse**  
**Drawing & Parts List 11/98 Form #10505A**

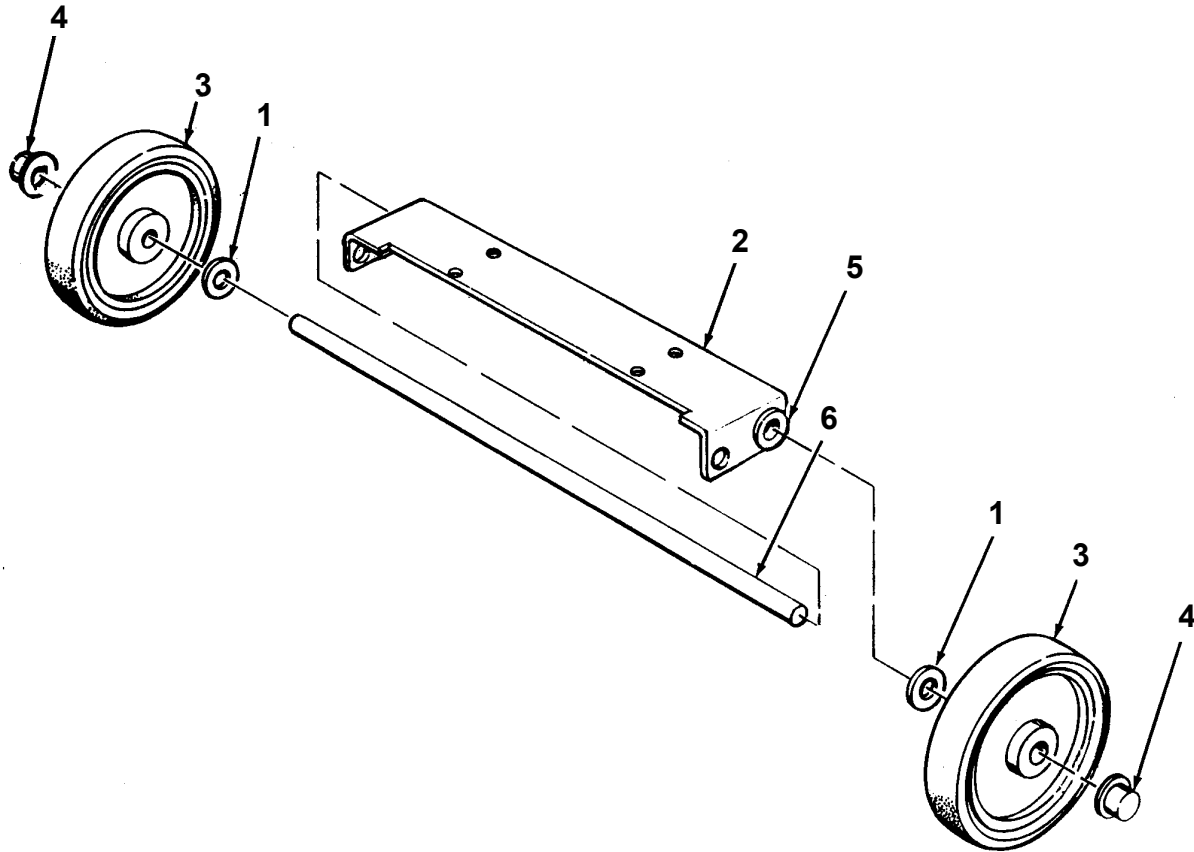

Ref	Part No.	Description	Qty
1	87607A	Washer, Nylon	2*
2	61247A	Bracket, axle	1
3	59934A	Wheel	2
4	920346	PAL Nut	2
5	601104	Bushing, Pivot	2
6	60149A	Shaft	1

Nominal

\*NOTE: Place washers as required to center the wheels  
 (Number of washers may vary)

**CLARKE TECHNOLOGY**  
**Vision 17E 115V**  
**Brush Lift Drawing & Parts List 11/98**  
**Form #16608A**

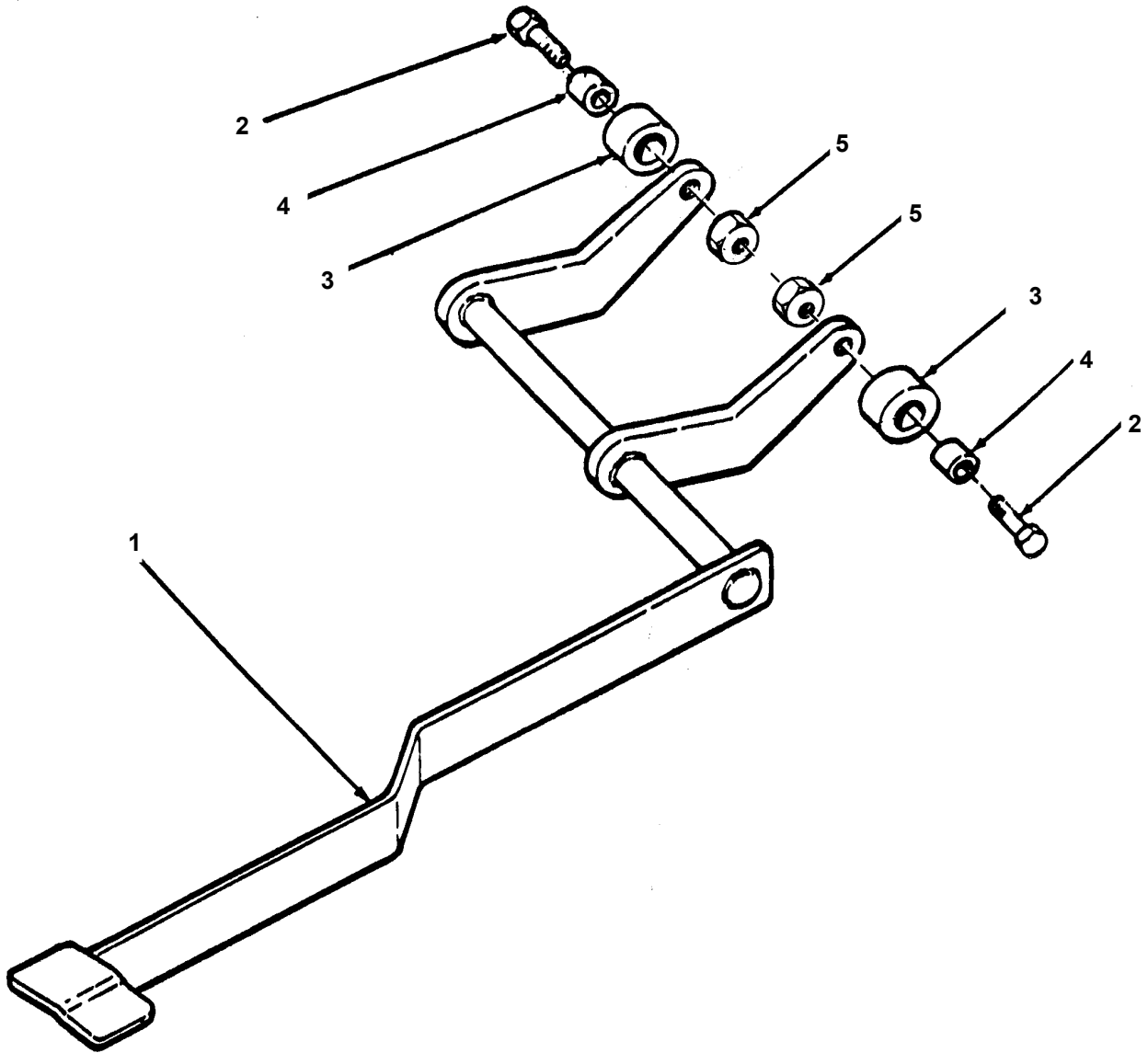

Ref	Part No.	Description	Qty
1	65424A	Lift Brush, Weldment	1
2	85600A	Screw 1/4 - 20	2
3	51516A	Bushing	2
4	608210	Spacer, Handle, Bolt	2
5	920208	Nut, 1/4-20	2

CLARKE TECHNOLOGY  
Vision 17E 115V  
ASM, Main Frame  
Drawing 2/01  
Form #16923A

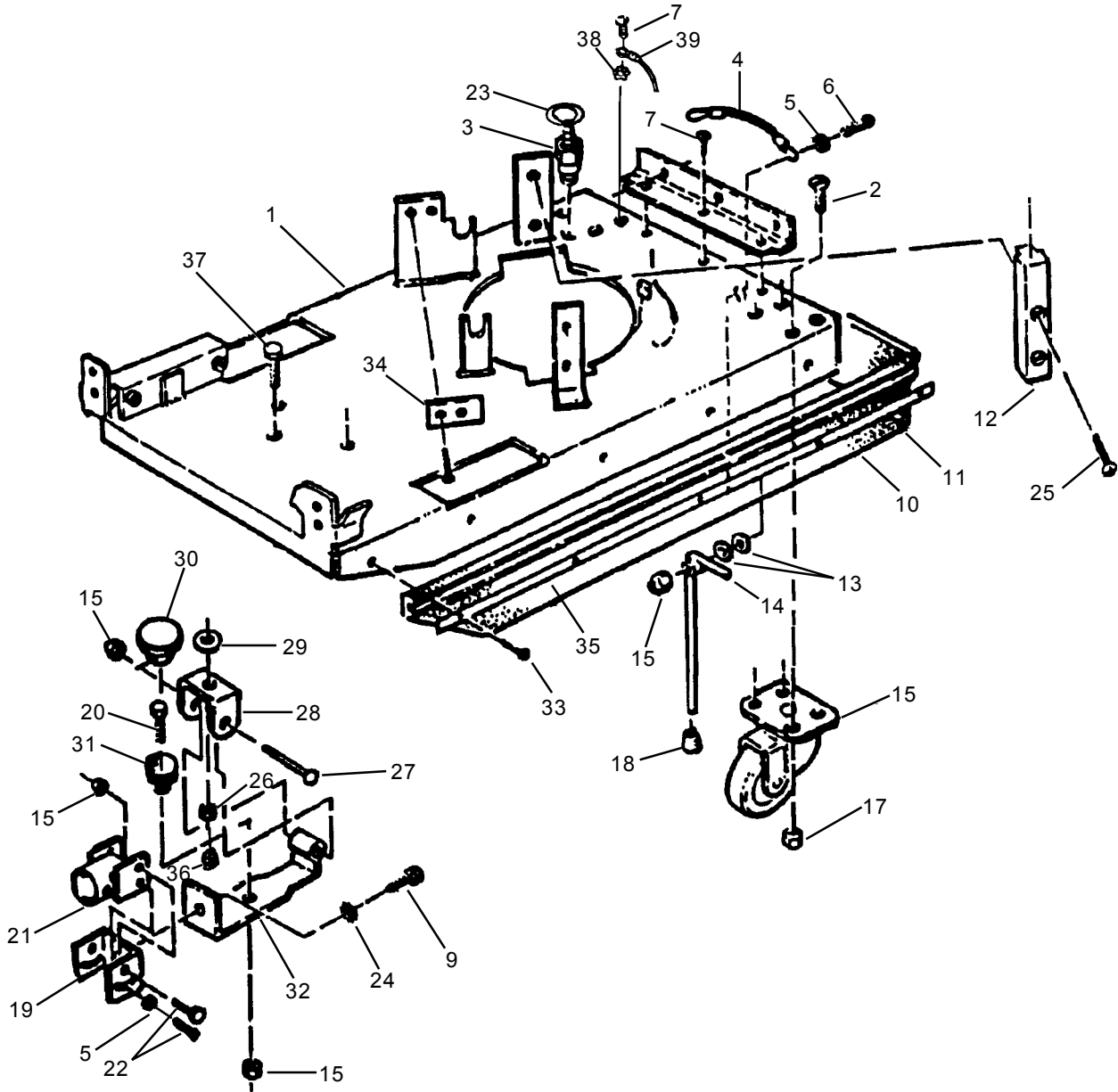

**CLARKE TECHNOLOGY**  
**Vision 17E 115V**  
**ASM, Main Frame**  
**Parts List 2/01**  
**Form #16923A**

<b>Ref</b>	<b>Part No.</b>	<b>Description</b>	<b>Qty</b>
1	63423B	Weldment, Main Frame	1
2	84238A	Screw <sup>5</sup> / <sub>16</sub> -18 X <sup>3</sup> / <sub>4</sub> Flat Hd SS	6
3	53618A	Adapter <sup>3</sup> / <sub>8</sub> X <sup>3</sup> / <sub>8</sub>	1
4	64456A	Handle	1
5	87026A	Washer, S.S. <sup>1</sup> / <sub>4</sub> " Flat	4
6	85384A	Screw <sup>1</sup> / <sub>4</sub> - 20 X <sup>1</sup> / <sub>2</sub>	2
7	85395A	Screw <sup>1</sup> / <sub>4</sub> - 20 X <sup>1</sup> / <sub>2</sub>	6
8	64505A	Hinge Tank	1
9	85822A	Screw <sup>3</sup> / <sub>8</sub> -16 x <sup>7</sup> / <sub>8</sub>	1
10	31227A	Shirt, Main Frame	1
11	66960A	Retainer, Skirt	3
12	38009A	Guide, Plastic	3
13	980442	Wave Washer	2
14	68733B	Kick Stand	1
15	81104A	Nut <sup>1</sup> / <sub>4</sub> - 20 Nylock	6
16	52117A	Caster, Swivel	2
17	920110	Nut, <sup>5</sup> / <sub>16</sub> - 18 Elastic	6
18	52047A	Cap	1
19	69028A	Squeegee Swival	1
20	85391A	Screw <sup>1</sup> / <sub>4</sub> - 20	1
21	60698A	Squeegee, Bracket	1
22	170915	Screw <sup>1</sup> / <sub>4</sub> -20 x <sup>3</sup> / <sub>4</sub>	4
23	722021	Clamp	1
24	87614A	Washer <sup>3</sup> / <sub>8</sub> Int., Ext.	1
25	84233A	Screw <sup>1</sup> / <sub>4</sub> - 20 Flat	6
26	67867A	Nut, Squeegee Spacer	1
27	85396A	Screw	1
28	61252A	Bracket, Swing Squeegee	1
29	87027A	Washer	2
30	30517A	Bushing Squeegee	1
31	58612A	Spring, Squeegee	1
32	68730B	Bracket, Arm Weldment	1
33	85397A	Screw 10 - 24 X <sup>3</sup> / <sub>8</sub> SS	12
34	66939A	Retainer	1
35	66961A	Retainer Skirt	2
36	81112A	Nut, 5/16-18 ESNA	1
37	84229A	Screw, 5/16-18 x .88	1
38	980614	Washer, 1/4 Star	1
39	49068A	Wire, Ground	1

**CLARKE TECHNOLOGY**  
**Vision 17E**  
**115V Brush Motor Assembly**  
**Drawing and Parts List 2/01**  
**Form #17115A**

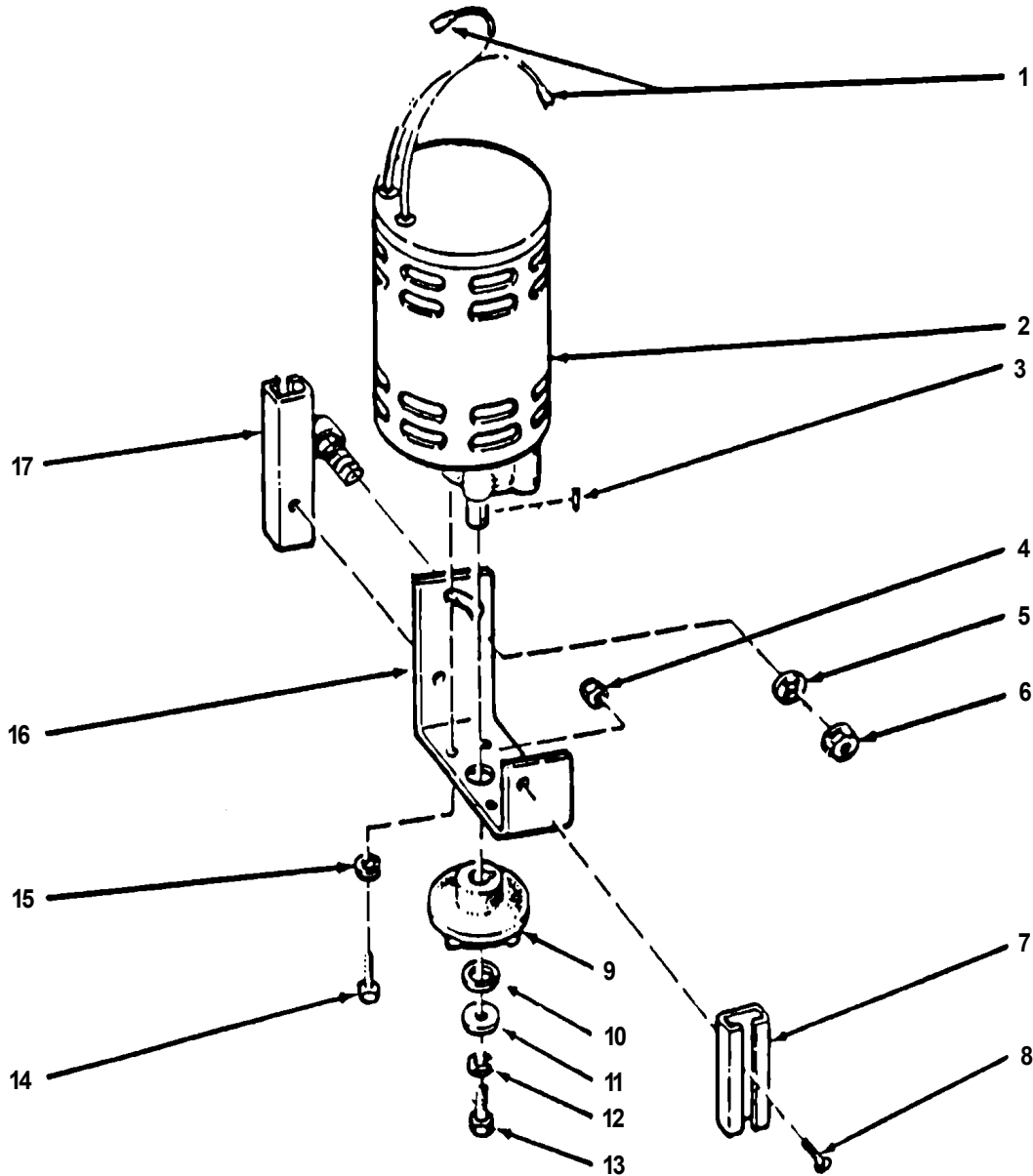

Ref	Part No.	Description	Qty
1	47710A	Terminal, Brush Motor	2
2	44713A	Gear Mtr. 200 RPM 115V	1
3	80501A	Key (with #4)	1
4	81104A	Nut 1/4 - 20 Nylock	2
5	980662	Washer	1
6	67865A	Spacer Tilt handle	
7	63600A	Guide RH	1
8	84242A	Screw 1/4 - 20 X 5/8	2
9	20308A	Adapter Motor	1

Ref	Part No.	Description	Qty
10	980679	Spacer Washer	1
11	980210	Washer Impeller	1
12	980652	Washer, Lock 5/16	1
13	85811A	Screw 5/16 Hex	1
14	85727A	Screw 3/8 - 16 X 1 Hex Head	4
15	980638	Lockwasher 3/8	4
16	61238A	Bracket Motor Lift	1
17	68761A	Guide LH	1

**CLARKE TECHNOLOGY**  
**Vision 17E - 115V**  
**Panel Assembly**  
**Drawing & Parts List 11/98**  
**Form #17644A**

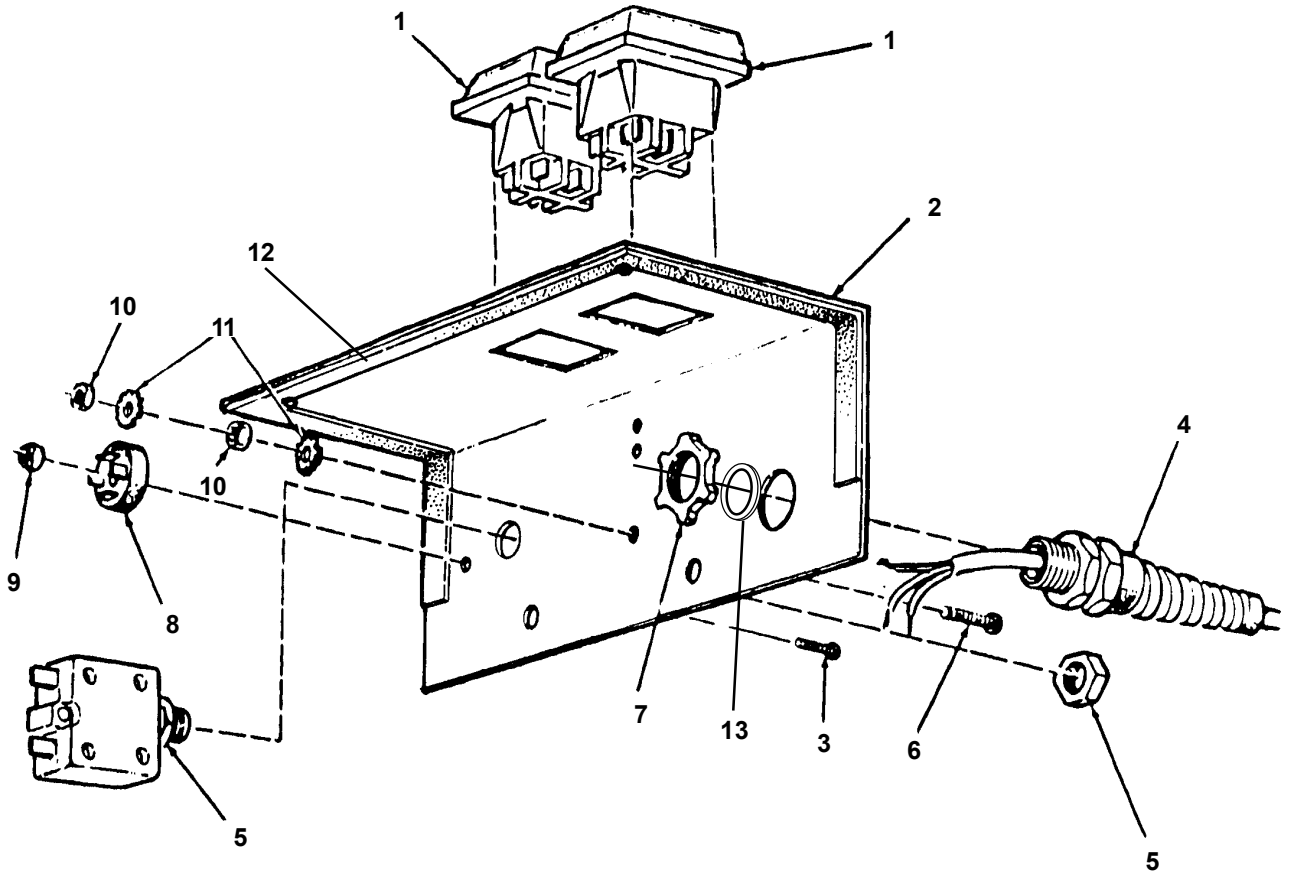

Ref	Part No.	Description	Qty
1	47316B	Switch, Rocker DPST	2
2	66177B	Panel, Control	1
3	962212	Screw, 6 X 32 X 7/8	1
4	42096A	Cord, Power Supply	1
5	41418A	Breaker, Circuit 10A	1
6	85383A	Screw, 10 - 32 X 5/4	1
7	82100A	Locknut, 1/2" Conduit	1
8	46106A	Rectifier, Bridge	1
9	920056	Nut, 6 - 32 Elastic	1
10	920224	Nut, 10 - 32 Hex	2
11	980603	Washer, Shakeproof	2
12	54349A	Gasket, Panel	1
13	170870	Washer	1
NI	699202	TIE, Wire	2
NI	49687A	Harness, Brush	1

CLARKETECHNOLOGY  
 Vision 17E 115V  
 Squeegee Assembly Drawing & Parts List 4/96  
 Form #18809A

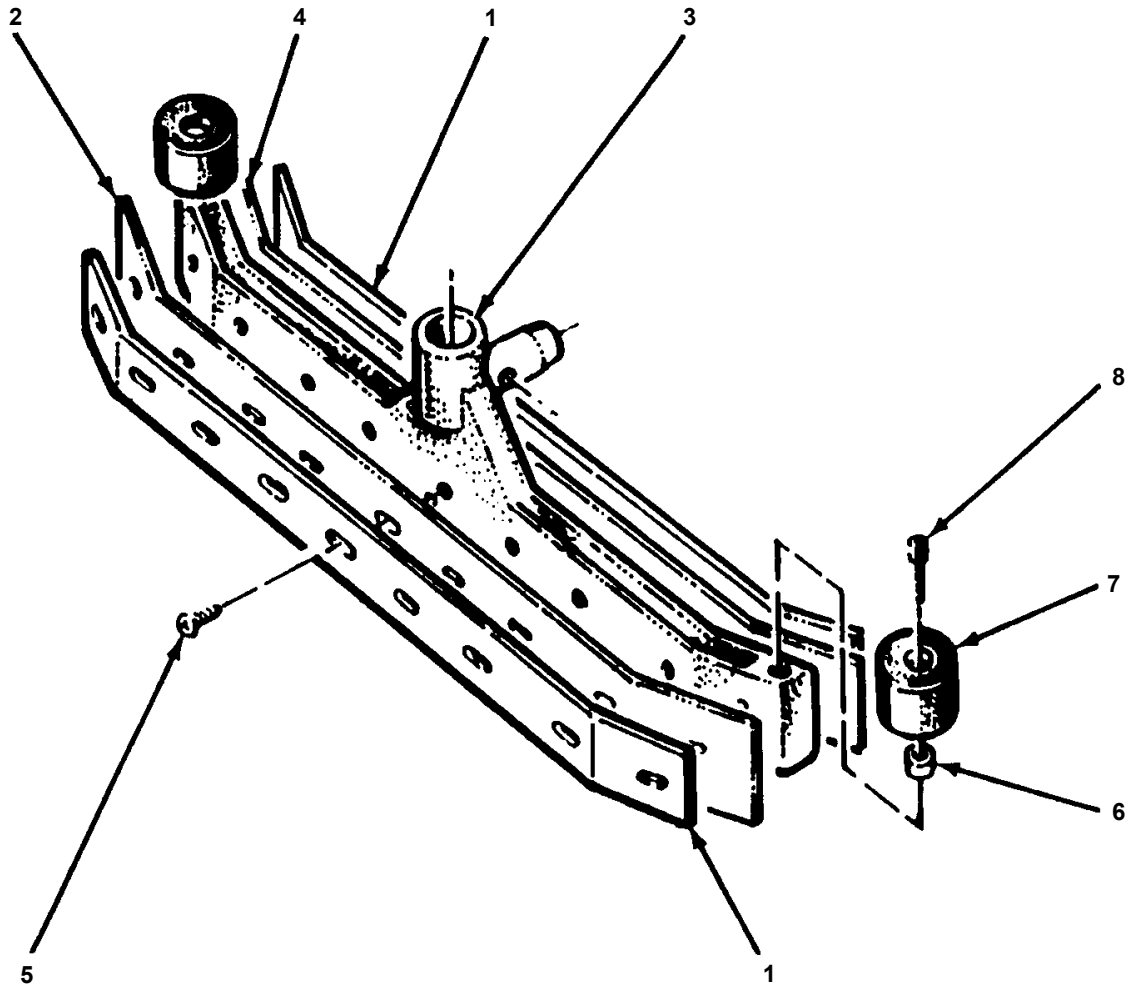

Ref	Part No.	Description	Qty
1	66921B	Retainer, Squeegee	2
2	30902A	Blade, Squeegee Rear	2
3	27703A	Squeegee, Casting	1
4	30903A	Blade, Squeegee Front	1
5	85398A	Screw 1/4 - 20 X 1/2	18
6	838201	Spacer, Wheel Guide	2
7	839702	Wheel, Brush Guide	2
8	962841	Screw, 5/16 - 18 x 1 1/4	2

**Blades Available:**

30918A	Blade, Sq., Front Nitrile/EPDM	1
30919A	Blade, Sq., Rear Nitrile/EPDM	1

**CLARKE TECHNOLOGY**  
**Vision 17E 115V**  
**Solution Tank Assembly**  
**Drawing & Parts List 2/01**  
**Form #19169A**

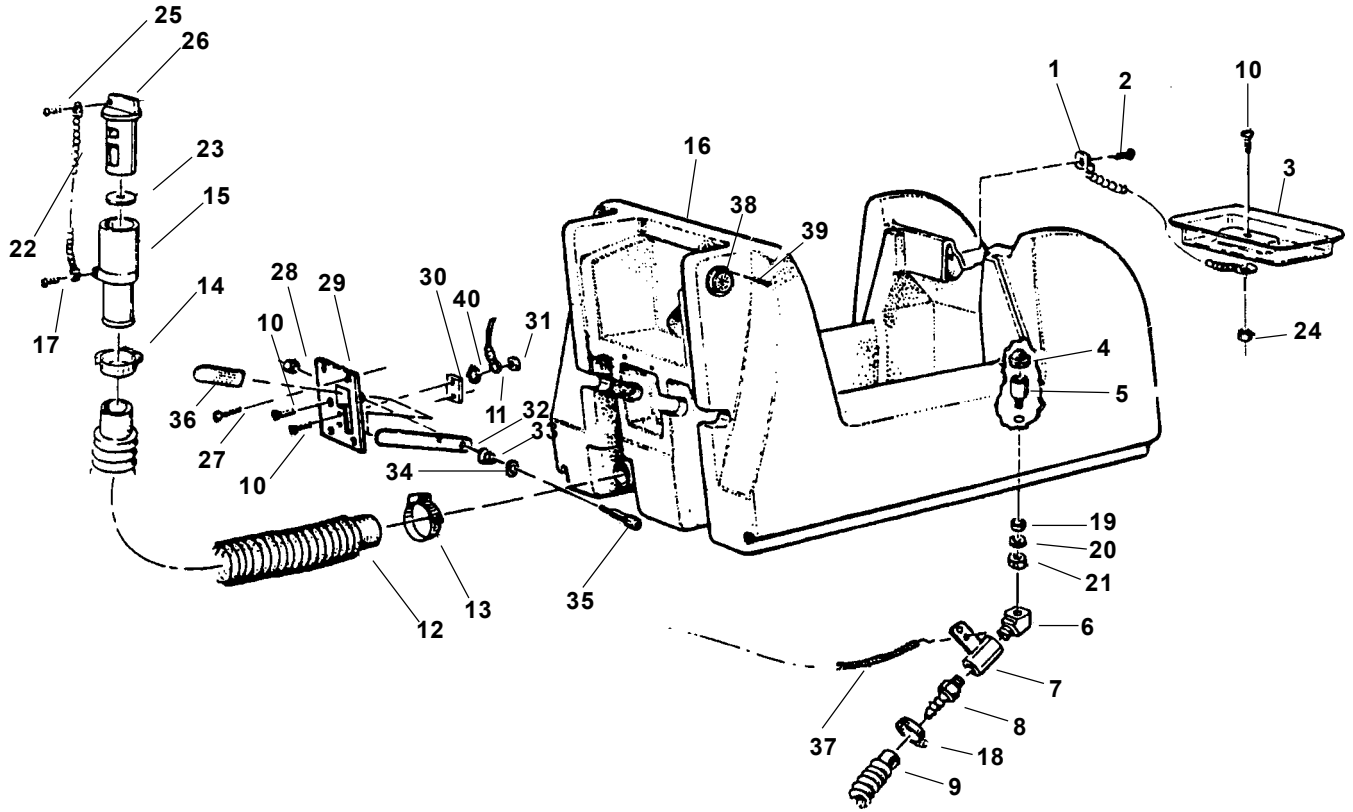

Ref	Part No.	Description	Qty
1	692409	Chain Cover	1
2	85519A	Screw 1/4 - 20 X 3/8	1
3	832322	Cover, Sol. Tank	1
4	878535	Strainer, Sol. Tank	1
5	60317A	Adapter, Filter	1
6	53614A	Elbow, Solution	1
7	849401	Valve, Solution	1
8	53618A	Adapter, 3/8 x 3/8	1
9	35138A	Hose, Solution	1
10	962798	Screw 10-24 X 1/2	1
11	49067A	Wire	1
12	30416A	Hose, Drain	1
13	752020	Clamp, Hose	1
14	832002	Clamp, Hose	1
15	839401	Drain	1
16	38964B	Tank, Solution	1
17	962943	Screw	1
18	722021	Clamp, Hose	1
19	833401	Gasket, Drain	1

Ref	Part No.	Description	Qty
20	980630	Washer	1
21	920264	Nut 3/4 - 16 Hex	1
22	52206A	Chain, Cover	1
23	833407	Gasket, Drain	1
24	81110A	Nut, 10-24	1
25	962987	Screw, 10-24 x 3/8	1
26	833901	Handle, Drain Valve	1
27	84237A	Screw, 10-32 x 1/2	2
28	81217A	Nut 1/4-20	1
29	68762A	Plate, Squeegee Lift	1
30	68646A	Plate, Wear	1
31	81110A	Nut, 10-24 Nylock S.S.	2
32	64476A	Handle, Squeegee Lift	1
33	53030A	Spring, Taper	1
34	980651	Washer	1
35	80031A	Bolt, Shoulder	1
36	52755A	Cover, Handle	1
37	52503A	Cable, Solution	1
38	36101A	Ratchet, Handle	2
39	84236A	Screw, 6-32	6
40	980603	Washer	1



**CLARKETECHNOLOGY**  
**Vision 17E 115V**  
**115V Vacuum Motor**  
**Drawing & Parts List 11/93**  
**#44906A**

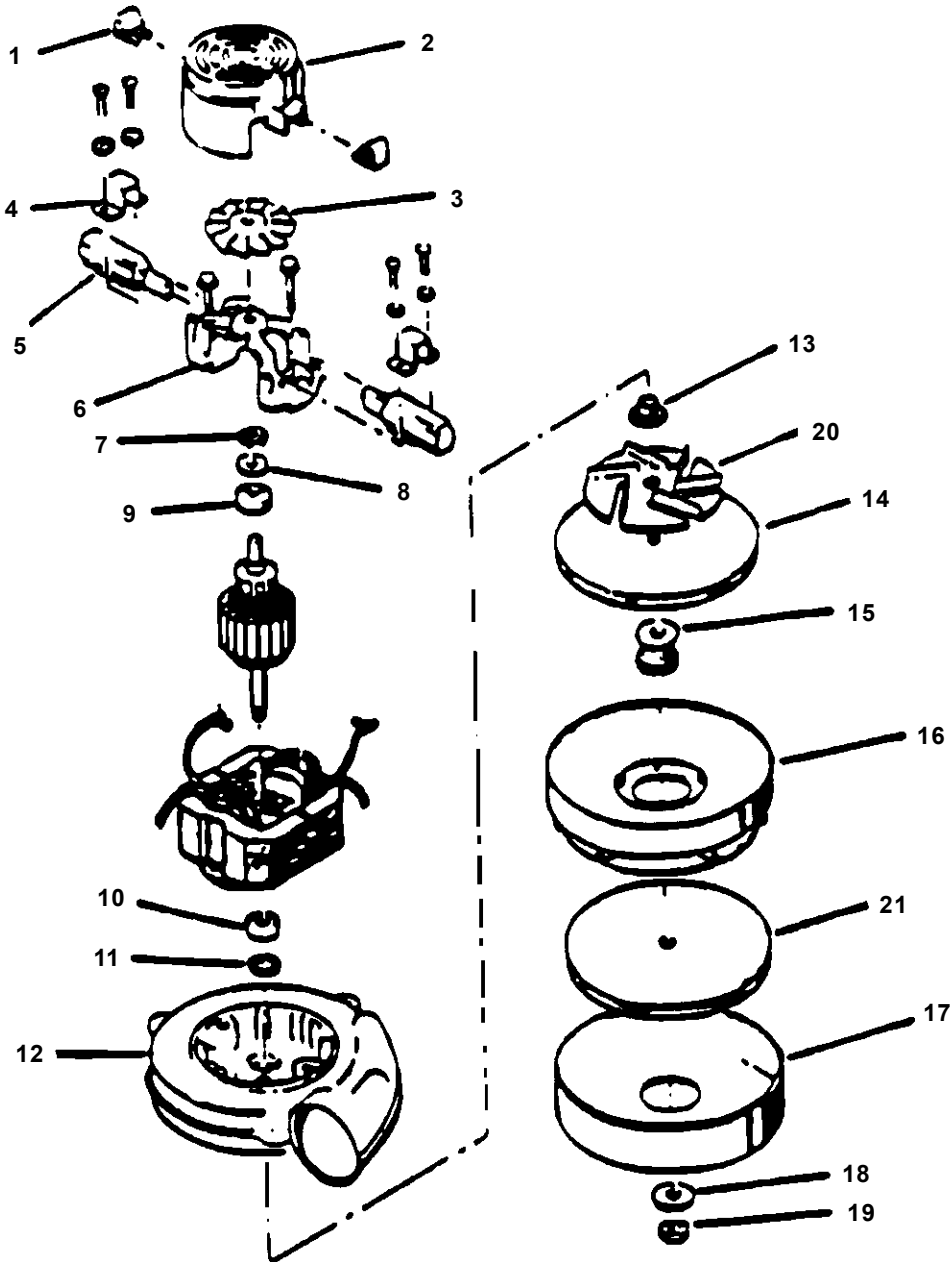

Ref #	Part No.	Description	Qty
1		Not Available	
2	54809A	Housing - Vent	1
3	53905A	Fan, Vent	2
4	51914A	Clamp	2
5	51419A	Carbon Brushes 115V	1
6	50618A	Commutator End Bracket	1
7	638313	Load Spring	1
8	53100A	Disc	1
9	902679	Ball Bearing	1
10	902648	Ball Bearing	1
11	59803A	Neoprene Washer	1

Ref #	Part No.	Description	Qty
12	50610A	Fan End Bracket	1
13	58501A	Spacer	1
14	53914A	Vacuum Fan	2
15	658201	Spacer	1
16	53908A	Stationary Fan	1
17	57904A	Fan Shell	1
18	980205	Washer	1
19	920329	Nut	1
20	53906A	Fan	1
21	53914A	Fan - Rotating	1

**CLARKETECHNOLOGY**  
**Vision 17 115V**  
**ASM, Gear Box #54238A**  
**Drawing & Parts List 11/93**

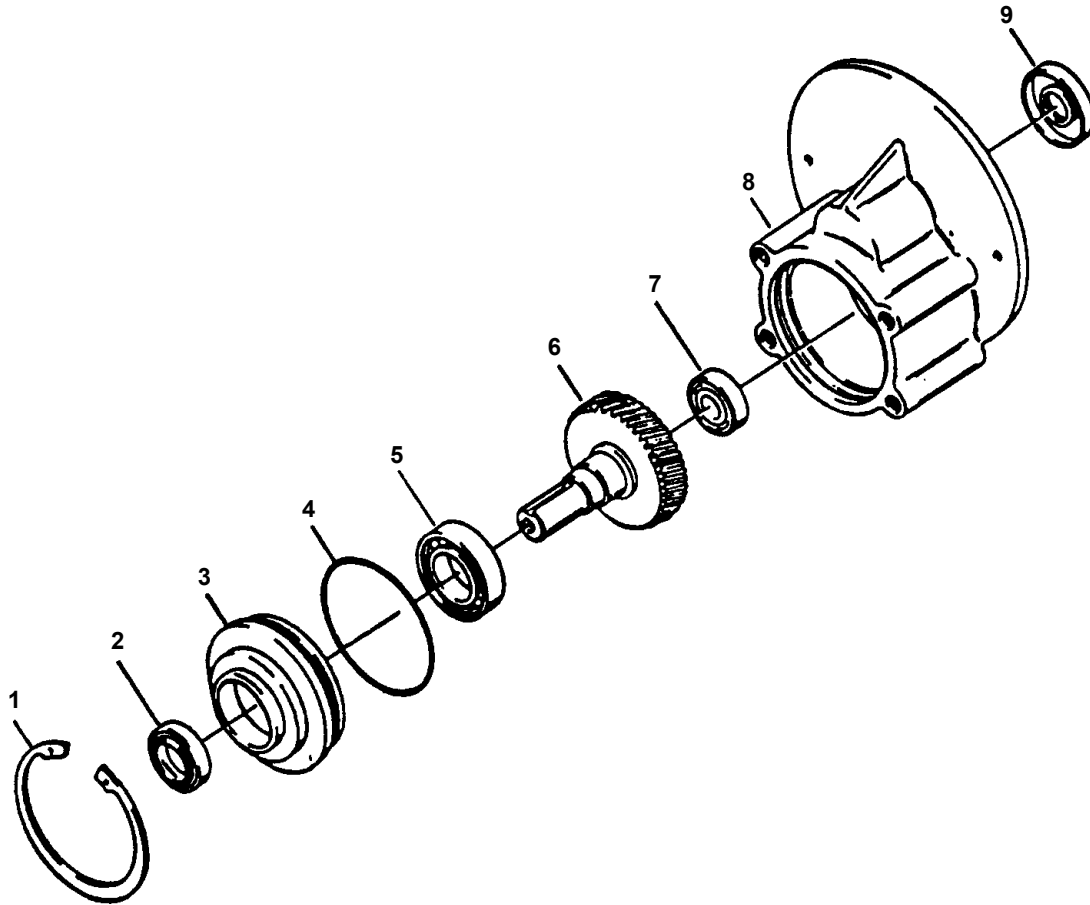

Ref	Part No.	Description	Qty
1	57846A	Ring, Snap	1
2	58143A	Seal, Oil, Small	1
3	52050A	Cap End	1
4	56668A	O - Ring	1
5	51176A	Bearing, Large	1
6	58316A	Shaft and Gear	1
7	902605	Bearing, Small	1
8	54883A	Housing	1
9	58144A	Seal, Oil Large	1
NI		Grease	1oz

**CLARKE TECHNOLOGY**  
**Vision 17E 115V**  
**Brush Motor 44713A**  
**Parts List 8/97**

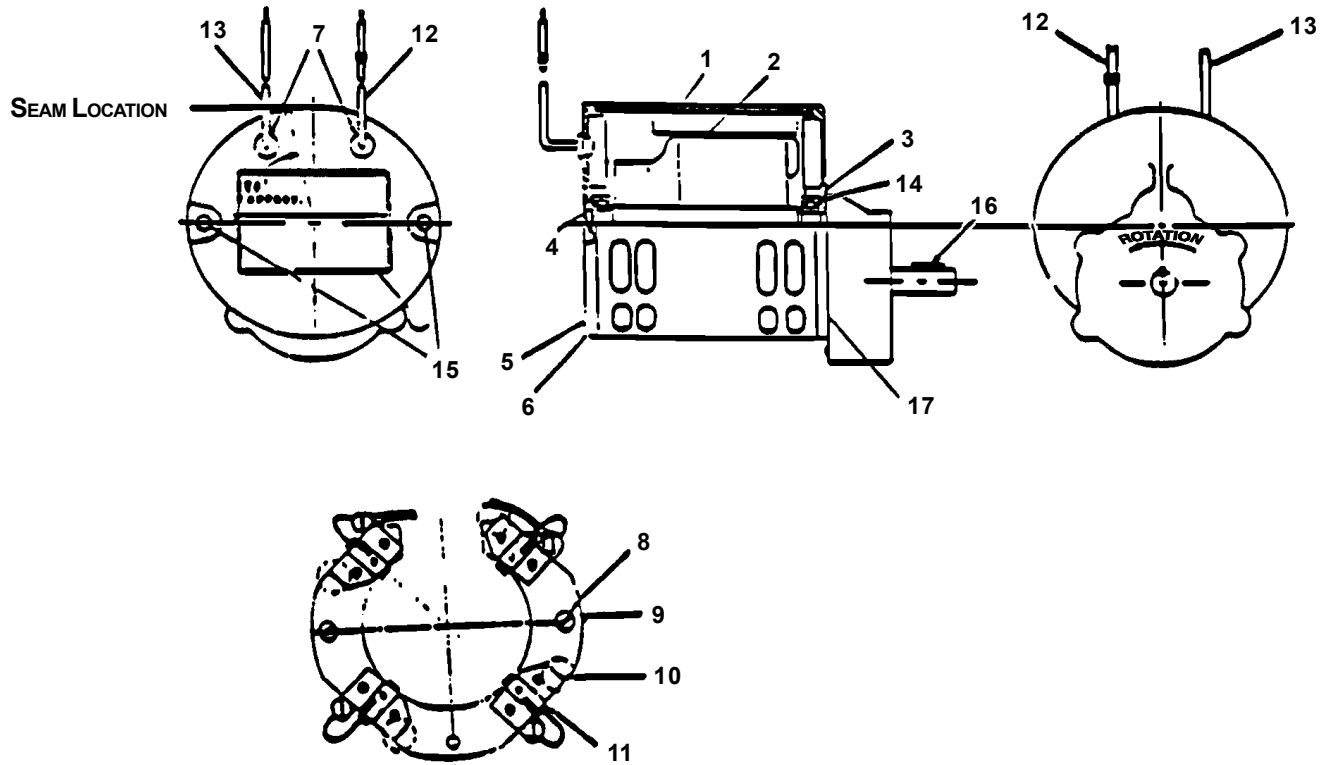

Item	Part No.	Description	Qty
1	56477A	Stator Frame Assembly (w/Magnets & Clips)	1
2	50141A	Armature Assembly (w. B.E. & F.E. Bearings)	1
3	902654	Bearings B.E.	1
4	902550	Bearing F.E.	1
5	51839A	Commutator Bracket Assembly (w/Brush BRD Assembly Leads)	1
6	50520A	Commutator Bracket	1
7	56480A	Strain Relief	2
8	962546	Brush Board Screw	2
9	50518A	Brush Board Assembly (w/ Springs & Brushes)	1
10	448396	Brush Spring	4
11	50516A	Brush	4
12	55654A	Lead Assembly	1
13	55655A	Lead Assembly	1
14	59805A	Helical Washer	1
15	50515A	Thru Bolt	2
16	80501A	Shaft Key	1
17	54238A	B.E. Bracket Assembly (Gear Box)	1

**CLARKE TECHNOLOGY**  
**Vision 17 E 115V**  
**Model #00370A - 115V Electrical Schematic 2/01**

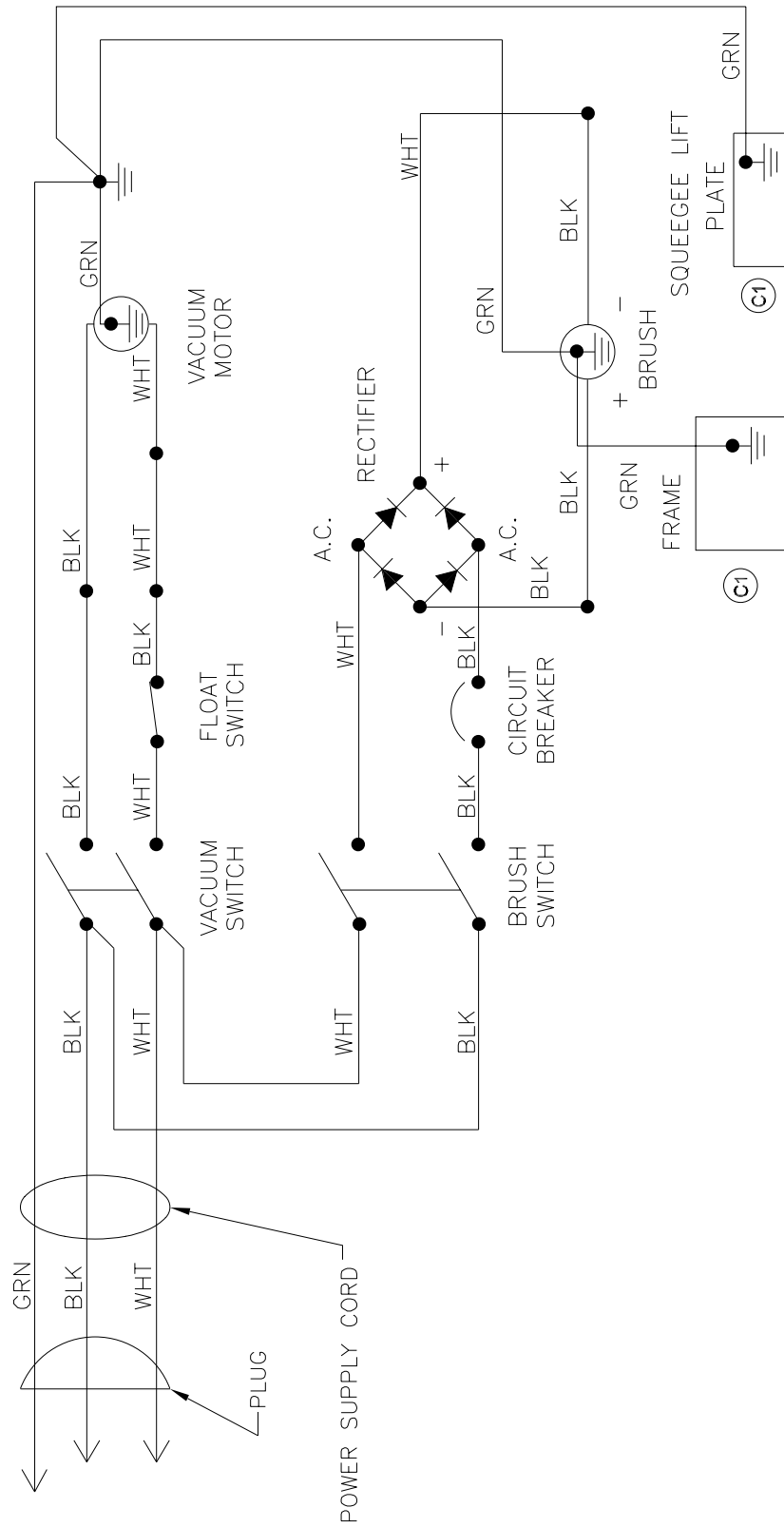

**CLARKETECHNOLOGY**  
**Vision 17 E 115V**  
**Model #00370A - 115V Connection Diagram 2/01**

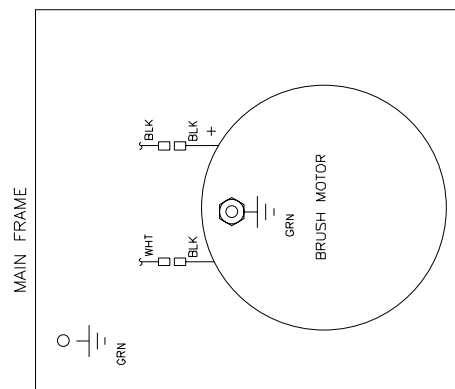
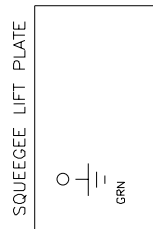
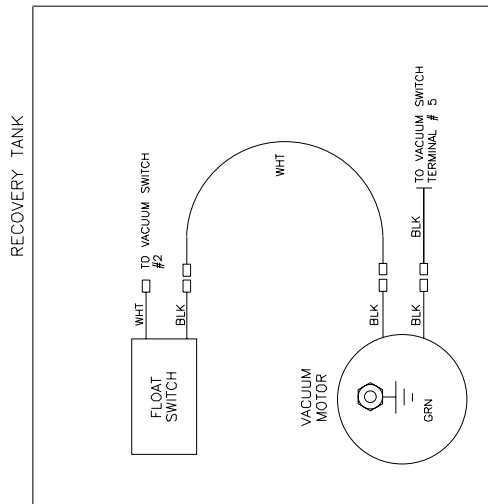
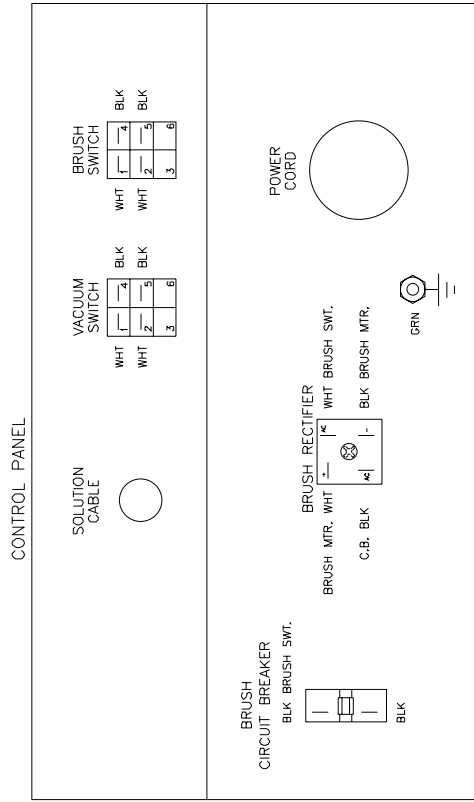

**CLARKETECHNOLOGY**  
**Vision 17BT**  
**Parking Brake Kit 10773A 6/98**

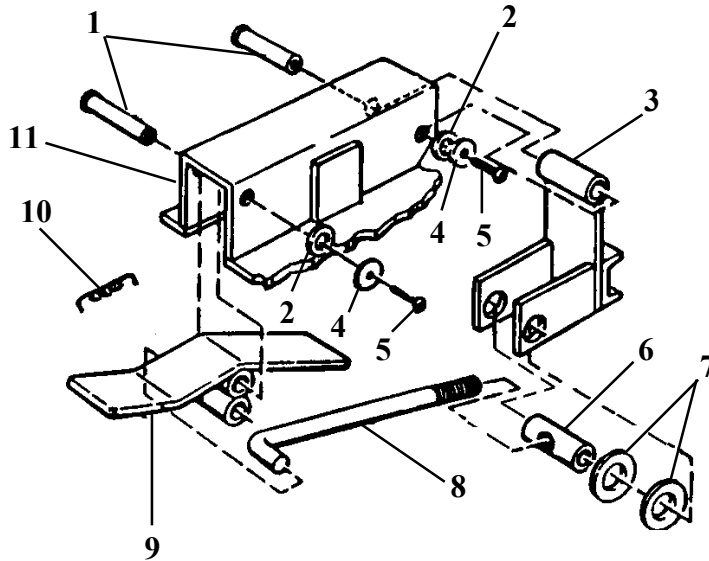

Ref #	Part #	Description	Qty.
1	66536A	Pin, Brake	2
2	87027A	Washer	2
3	17519A	Brake, Pad Weldment	1
4	87036A	Washer, #10 S.S.	2
5	85397A	Screw, 10-24 x 3/8 S.S.	2
6	67422A	Shaft, Brake	1
7	87613A	Washer, Nylon	2
8	67133A	Rod, Brake	1
9	10735A	Pedal, Brake	1
10	608340	Spring, Brake	1
11	Ref.	Machine Frame	ref.

The brake control prevents the movement of the machine. The brake pedal is at the back of the machine in the lower left corner. To activate the brake, push the pedal down. Lift the pedal to release the brake.

# ALTO® PRODUCT SUPPORT BRANCHES

## U. S. A. Locations

### HEAD OFFICE

ALTO U.S. Inc., St. Louis, Missouri  
16253 Swingley Ridge Road, Suite 200  
Chesterfield, Missouri 63017-1725

### PRODUCTION FACILITIES

ALTO U.S. Inc., Springdale, Arkansas  
2100 Highway 265  
Springdale, Arkansas 72764  
(501) 750-1000  
**Customer Service - 1-800-253-0367**  
**Technical Service - 1-800-356-7274**

ALTO U.S. Inc., Bowling Green, Ohio 43402  
1100 Haskins

### SERVICE FACILITIES

ALTO U.S. Inc., Carlstadt, New Jersey 07072  
150 Commerce Road  
(201) 460-4774

ALTO U.S. Inc., Elk Grove, Illinois 60007  
2280 Elmhurst Road  
(847) 956-7900

ALTO U.S. Inc., Denver, Colorado 80204  
1955 West 13th Ave.  
(303) 623-4367

ALTO U.S. Inc., Houston, Texas 77040  
7215 North Gessner Road

### SALES AND SERVICE FACILITIES

ALTO U.S. Inc., Madison Heights, Michigan 48071-0158  
29815 John R.  
(810) 544-6300

ALTO U.S. Inc., Marietta, Georgia 30062  
1355 West Oak Common Lane  
(770) 973-5225

---

**CLARKE TECHNOLOGY**  
**AMERICAN SANDERS TECHNOLOGY**  
**A.L. COOK TECHNOLOGY**  
**Customer Service Headquarters and Factory**  
2100 Highway 265  
Springdale, Arkansas 72764  
(501) 750-1000  
**Technical Service**  
1-800-356-7274

## European Locations

### PRODUCTION FACILITIES

ALTO Danmark A/S, Aalborg  
Blytaekkervej 2  
DK-9000 Aalborg  
+45 72 18 21 00

ALTO Danmark A/S, Hadsund  
Industrikvarteret  
DK-9560 Hadsund  
+45 72 18 21 00

### SALES SUBSIDIARIES

ALTO Canada Ltd., Rexdale Ontario  
24 Constellation Ct.  
(416) 675-5830

ALTO Overseas Inc., Sydney (Australia)  
1B/8 Resolution Drive  
Caringbah NSW 2229  
+61 2 9524 6122

ALTO Cleaning Systems Asia Pte Ltd., Singapore  
No. 17 Link Road  
Singapore 619034  
+65 268 1006

ALTO Deutschland GmbH, Bellenberg (Germany)  
Guido-Oberdorfer-Strabe 2-8  
89287 Bellenburg  
+49 0180 537 3737

ALTO Cleaning Systems (UK) Ltd., Penrith  
Gilwilly Industrial Estate  
Penrith  
Cumbria CA11 9BN  
+44 1768 868 995

ALTO France S.A. Strasbourg  
B.P. 44, 4 Place d'Ostwald  
F-67036 Strasbourg  
Cedex 2  
+33 3 8828 8400

ALTO Nederland B.V. Vianen  
Stuartweg 4C  
NL-4131 NJ Vianen  
+31 347 324000

ALTO Sverige AB, Molndal (Sweden)  
Aminogatan 18  
Box 4029  
S-431 04 Molndal  
+46 31 706 73 00

ALTO Norge A/S, Oslo (Norway)  
Bjornrudveien 24  
N-1266  
+47 2275 1770

## **CLARKE TECHNOLOGY U.S. LIMITED WARRANTY**

This Clarke Industrial/Commercial Product is warranted to be free from defects in materials and workmanship under normal use and service for a period of one year from the date of purchase, when operated and maintained in accordance with Clarke's Maintenance and Operations instructions.

This brush drive and traverse motors are warranted to be free from defects in materials and workmanship under normal use and service for one year from the date of purchase, provided the motors are inspected for carbon motor brush wear at six-month intervals by an authorized Clarke repair station. Failure to comply with the six-month inspection requirement or failure to replace worn motor brushes identified during the inspection will void the one-year warranty on the motors. Cost of the six-month inspection and replacement of carbon motor brushes is the responsibility of the purchaser. In the event of a warranty claim on the motors, proof of inspection and any required motor brush replacement must be provided.

This warranty is extended only to the original purchaser for use of the product. It does not cover normal wear parts such as electrical cable, rubber parts, and motor brushes.

Clarke's liability under this warranty is limited to repair of the product and/or replacement of parts and is given to purchaser in lieu of all other remedies, including INCIDENTAL AND CONSEQUENTIAL DAMAGES.

THERE ARE NO EXPRESS WARRANTIES OTHER THAN THOSE SPECIFIED HEREIN. THERE ARE NO WARRANTIES WHICH EXTEND BEYOND THE DESCRIPTION OF THE FACE HEREOF. NO WARRANTIES, INCLUDING BUT NOT LIMITED TO WARRANTY OF MERCHANTABILITY, SHALL BE IMPLIED. A warranty registration card is provided with your Clarke product. Return the card to assist Clarke in providing the performance you expect from your new floor machine.

If a difficulty develops with the product, you should: a) Contact the nearest authorized Clarke repair location or contact the Clarke Service Operations Department, 2100 Highway 265, Springdale, Arkansas 72764, for the nearest authorized Clarke repair location. Only these locations are authorized to make repairs to the product under this warranty. (b) Return the product to the nearest Clarke repair location. Transportation charges to and from the repair location must be prepaid by the purchaser. Clarke will repair the product and/or replace any defective parts with out charge within a reasonable time after receipt of the product.

ALTO U.S. Inc., 2100 Highway 265, Springdale, Arkansas 72764.

## **CLARKE TECHNOLOGY: POLYDUR® AUTOMATIC SCRUBBER SOLUTION AND RECOVERY TANK FIVE-YEAR GUARANTEE**

Your new Clarke Vision Automatic Scrubber has polydur Solution and Recovery Tanks. Polydur is a rotationally molded, medium-density linear polyethylene that won't crack or dent, and withstands most corrosives and temperature extremes. Clarke backs up your Polydur tanks with a five-year guarantee. If a tank breaks or leaks under normal use within five years of the date of purchase, it will be replaced free.

## **CLARKE TECHNOLOGY UNIBODY FRAME THREE-YEAR WARRANTY**

Clarke warrants the frame for the new Vision automatic Scrubbers for a period of three years against defects in materials and workmanship under normal use and service.

**CLARKE TECHNOLOGY reserves the right to make changes or improvements to its machine without notice.**

**Always use genuine Clarke Parts for repair.**



**CLARKE TECHNOLOGY  
2100 Highway 265  
Springdale, Arkansas, 72764**