



## **Electronic Service Manuals**

This electronic document is provided as a service to our customers. We do not create the contents of the information contained in this document. Should you have detailed questions pertaining to the information contained in this document, you may contact Michco, or the manufacturer which provided the original information in this electronic deliverable. Michco's only part in this electronic deliverable was the electronic assembly process. By providing this manual online we are not guaranteeing parts availability.

You may contact Michco through the following methods:

**Phone (517) 484-9312**

2011 N. High St. -- Lansing, Michigan -- 48906

Fax: (517) 484-9836

Email: [CustomerService@Michco.com](mailto:CustomerService@Michco.com)

Website: [www.Michco.Com](http://www.Michco.Com)

Order Parts online at:

**[www.Michco.Com](http://www.Michco.Com)**

Directly to Parts & Service:

By Email: **[CustomerService@Michco.com](mailto:CustomerService@Michco.com)**

By Fax: (517) 484-9836

By Voice: (517) 484-9312

**Serving the Cleaning Industry Since 1922**

Notice: All copyrighted material remains property of original owners, all trademarks are property of respective owners. Manuals are subject to Manufacturer's reproduction limitations. Originals or reproductions were provided by manufacturers through a request. We make no warranty as to the correctness of information provided in this document and you assume all risk. By placing these manuals on line we are not declaring our corporation to be an manufacturer authorized dealer or provider, please check our web site for authorized manufacturers we represent.

# WS36T RIDER

**ORDER #86010**

**Betco Watchman™  
36" Rider Automatic Scrubber**

## FEATURES

- Simple design for easy operation
- Large tank capacities
- Easy access parts design
- Heavy duty curved squeegee assembly
- Quick change squeegee blades
- Electronic float shut-off

The Betco Watchman series of automatic scrubbers bring a new dimension to cleaning maintenance. A simple design makes the WS36T ride on scrubber easy to operate and reduces operator training. The 36" cleaning path and large tank capacities increase productivity. The heavy duty squeegee assembly achieves maximum water recovery and easy access to all areas of the machine reduces service down time. Betco's Watchman automatic scrubbers are built durable to last and will help make your next cleaning job easier!

## WARRANTY

Tank: 10 Year

Other components: 3 Year\*

\*Please refer to Betco Equipment Price/Product Guide for complete equipment warranty information.



## SPECIFICATIONS

- Cleaning path: 36"
- Pad driver: (2) 18"
- Brush motor: (1) 2 hp
- Brush pressure: 0 - 185 lbs.
- Brush speed: 225 rpm
- Vacuum motor: (1) .75 hp
- Noise level: 68 db
- Water lift: 63"
- Drive motor: 1 hp variable speed
- Maximum drive speed: 3.5 mph
- Solution control: Gravity feed adjustable
- Solution tank: 55 Gallons
- Recovery tank: 60 Gallons
- Volts: 36 volt system
- Batteries: (3) 12 volt
- Run time: Approximately 3.5 hours
- Weight w/o Batteries: 1000 lbs.  
Weight w/batteries: 1,640 lbs.
- Tires: Heavy duty non-marking
- Dimensions: Length: 73" Width: 38.5"  
Height: 58" Squeegee Width: 49"
- Productivity: 60,000 sq. ft./hour

## APPLICATIONS

- General Cleaning
- Heavy Duty Cleaning
- Stripping

## OPTIONS

Nylon Brushes #86341  
Grit Brushes #86342  
Charger #86203  
Battery (3) #86278

**Authorized Betco Distributor:**

**Better Resources. Better Results.**  
**BETCO®**

1001 Brown Avenue • P.O. Box 3127 • Toledo, Ohio 43607-0127  
©All Rights Reserved 8/01 • Reorder #86010 • email@betco.com • www.betco.com

# WS36T Watchman™ 36" Rider Auto Scrubber

## Parts Schematic

Item #86010



DESCRIPTION:

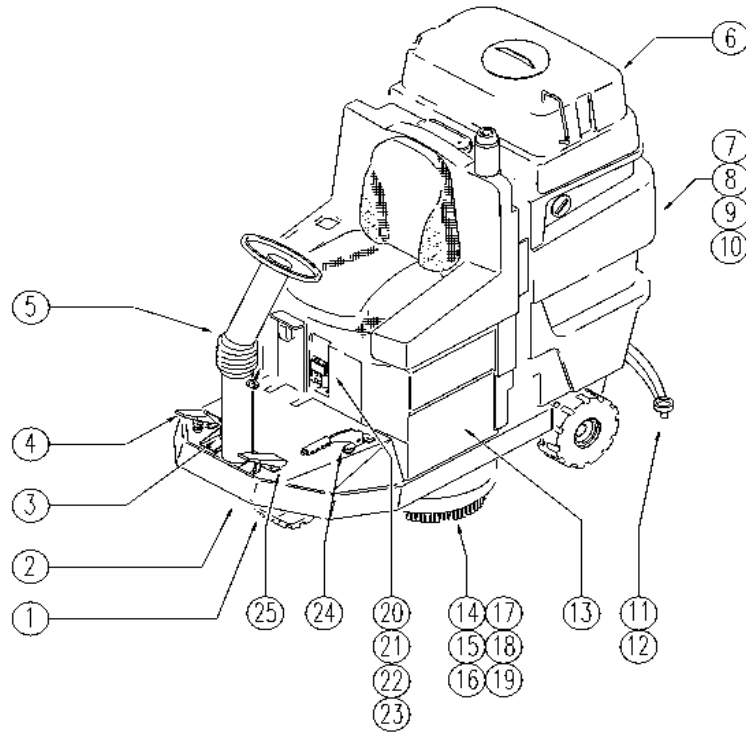

REF.	CODE	DESCRIPTION	QT
1	PL1045	WHEEL	
2	PL1050	CHASSIS	
3	PL1052	PEDAL BRAKE	
4	PL1051	DRIVE	
5	PL1044	STEERING COLUMN	
6	PL1216	TANK	
7	PL1039	TANK-HYDRAULIC UNIT	
8	PL1040	TANK-SUCTION	
9	PL1041	TANK-ACCESSORIES	
10	PL1217	TANK-ACCESSORIES	
11	PL1070	SQUEEGEE LIFT	
12	PL1069	SQUEEGEE LIFT	
13	PL1058	BATTERY CASE	
14	PL1033	HEAD 95: MOTOR	
15	PL1381	HEAD 95-FLAP AND BOX	
16	PL1034	HEAD 95-PULLEY AXLE	
17	PL1048	FRONT HEAD LIFTING	
18	PL1047	REAR HEAD LIFTING	
19	PL1215	HEAD FASTENER	
20	PL1060BC	ELECTRIC UNIT 1	
21	PL1061	ELECTRIC UNIT 2	
22	PL1062	ELECTRIC UNIT 3	
23	PL1063	ELECTRIC UNIT 4	
24	PL1053	HAND BRAKE	
25	PL1066	SQUEEGEE PEDAL	
	PL1237	BRUSH	
	PL1277	EXTERNAL PARTS	
	WD27126-2	WIRING DIAGRAM	

		CODE:			pl1033 aa SN from 98A100	
DESCRIPTION:	HEAD 95:MOTOR	KOPF 95:MOTOR	TETE 95:MOTEUR	CABEZA 95:MOTOR	TESTATA 95:MOTORE	

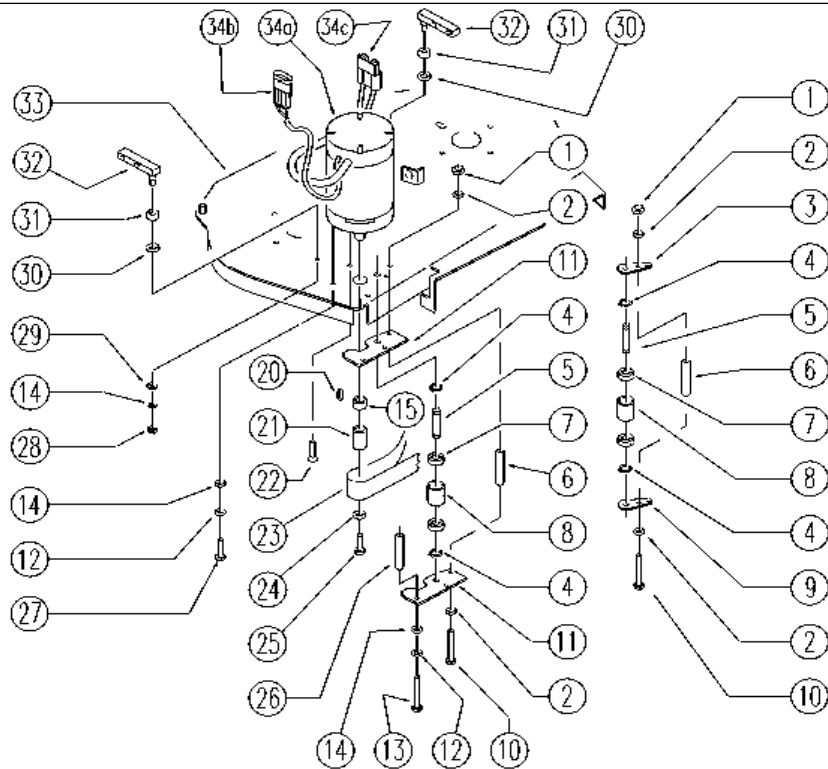

REF.	CODICE	DESCRIPTION	QT
1	E86552	nut	3
2	E86707	Cham Washer D10	6
3	SL09855	PLATE	1
4	E89408	Stop Ring	4
5	E86666	AS28 Pin	2
6	E89485	Spacer	3
7	E86667	Bearing, 6001 2RS	4
8	E86727	Neutral Pulley	2
9	SL09854	PLATE	1
10	E86553	screw	3
11	E86665	Plate (Idler Bearing)	2
12	E86702	Cham Washer D8	3
13	E86554	screw	2
14	E86726	Washer	5
15	E87755	Spacer	1
20	E86536	Key	1
21	E87756	Pulley	1
22	SL04283	SCREW	1
23	E86820	Belt	1
24	E87757	Washer	1
25	E87758	Screw	1
26	E86555	spacer	2
27	SL04083	SCREW	1
28	E86853	Nyloc Hex Nut, M8 Zinc	2
29	E86881	Washer	2
30	E86980	Washer D13-24-2.5	2
31	E86975	Rubber Gasket	2
32	SL09629	BRACKET	2
33	SL09884	PLATE	1
34a	E86803	Brush Motor	1
34b	E87903	Connector	1
34c	E86580	Connector, SB50, Gray	1
34d	E86804	Carbon Brushes	2

		<b>CODE:</b>		p11034 aa SN from 98A100	
<b>DESCRIPTION:</b>	HEAD 95	KOPF 95	TETE 95	CABEZA 95	TESTATA 95:SPAZZOLA

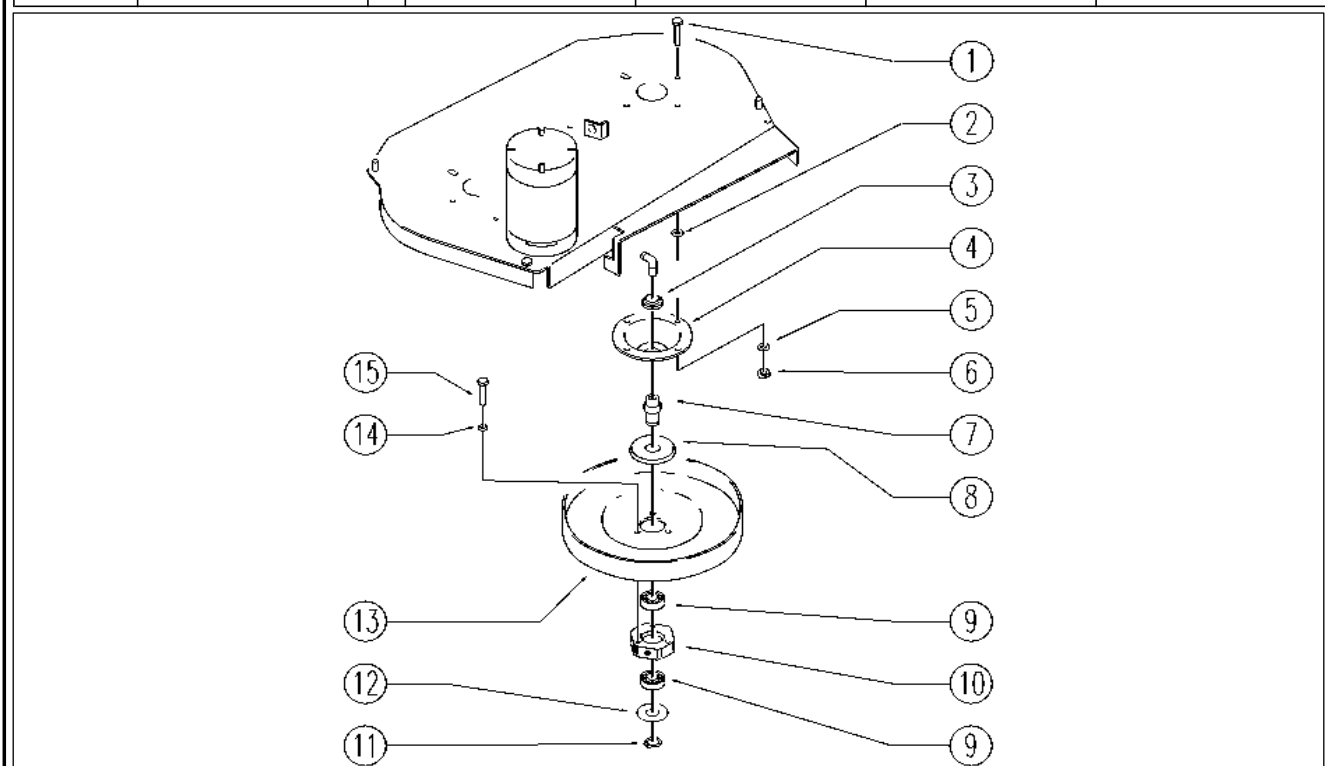

REF.	CODE	DESCRIPTION	QT
1	E86978	Screw M8-25	8
2	E88091	Washer	8
3	E86468	AS20 Nut	2
4	E86725	Flange, WS20	2
5	E86726	Washer	8
6	E86853	Nyloc Hex Nut, M8	8
7	E86982	Hexagon Pin - Rhino	2
8	E86618	Upper Protection	2
9	E86409	Bearing, 6005 2RS	4
10	E86983	Hexagon ASM	2
11	E86812	Seeger	2
12	E86617	Lower Protection	2
13	E89396	Pulley	2
14	E86707	Cham Washer D10	6
15	E86977	Screw M5-16	6

		CODE:	pl1039 ad SN from 00G100		
DESCRIPTION:	HYDRAULIC UNIT	HYDRAULISCHE GRUPPE	GRUPE HYDRAULIQUE	GRUPO HIDRAULICO	GRUPPO IDRAULICO

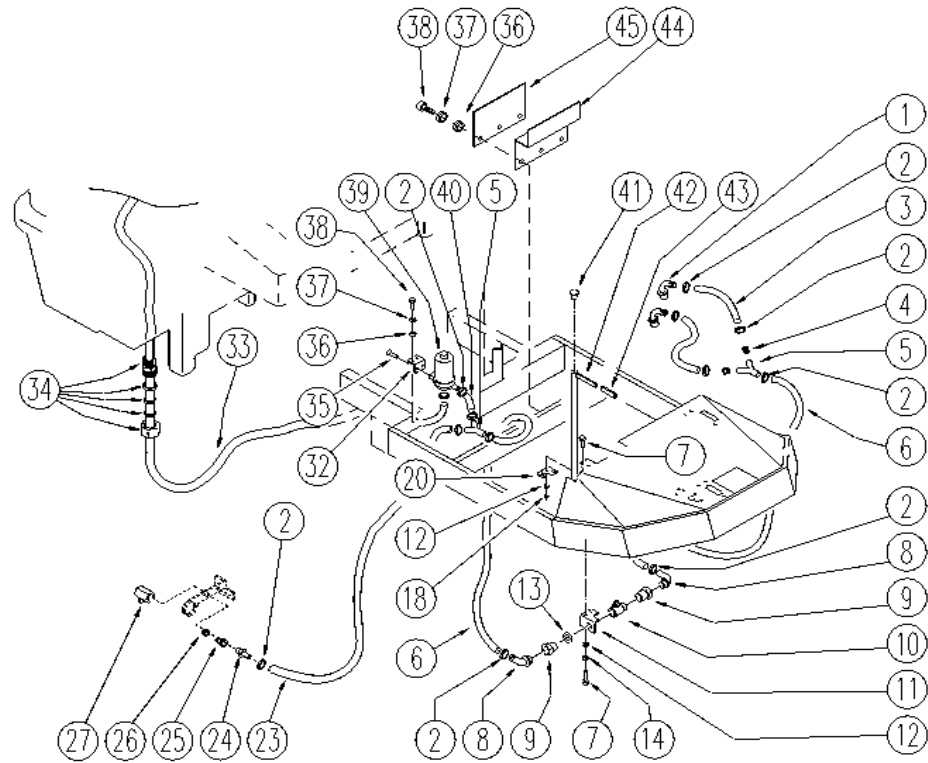

REF	CODE	DESCRIPTION	QT
1	E86638	Union Elbow	2
2	E86546	clamp WS36	13
3	SL19283	HOSE	2
4	SL07375	UNION / CONNECTOR	2
5	SL18367	CONNECTOR	2
6	SL19284	HOSE	2
7	E89486	Screw	4
8	E86940	L Coupling, 3/8" D.15	2
9	E86377	reduction	2
10	E86971	Water Valve	1
11	SL09958	SUPPORT	1
12	E86707	Cham Washer D10	4
13	E89096	Washer	1
14	E86700	Cham Washer D6	2
18	E86875	Self-Locking Nut	2
20	SL09959	BLOCK / LOCK	1
23	SL19328	HOSE	1
24	E89095	Union/connector	1
25	E86377	reduction	1
26	E89096	Washer	1
27	SL18380	TAP	1
32	SL09961	SUPPORT	1
33	SL19322	HOSE	1
34	E86570	union	1
35	E86976	Screw M6-12	2
36	E86797	Washer	5
37	SL06021	WASHER	5
38	E89469	M4 - 15 Screw	5
39	E86936	Solution Pump	1
40	SL19289	HOSE	1
41	SL14242	CAP	1
42	E86950	Lever	1
43	E86450	Tank Support Handle	1
44	SL39054	PLATE	1
45	SL39055	PLATE	1

		<b>CODE:</b>	p11040 ae SN from 00E200		
<b>DESCRIPTION:</b>	TANK : SUCTION	TANK:ANSAUGUNG	RESERVOIR : ASPIRATION	TANQUE: SUCCION	SERBATOIO: ASPIRAZIONE

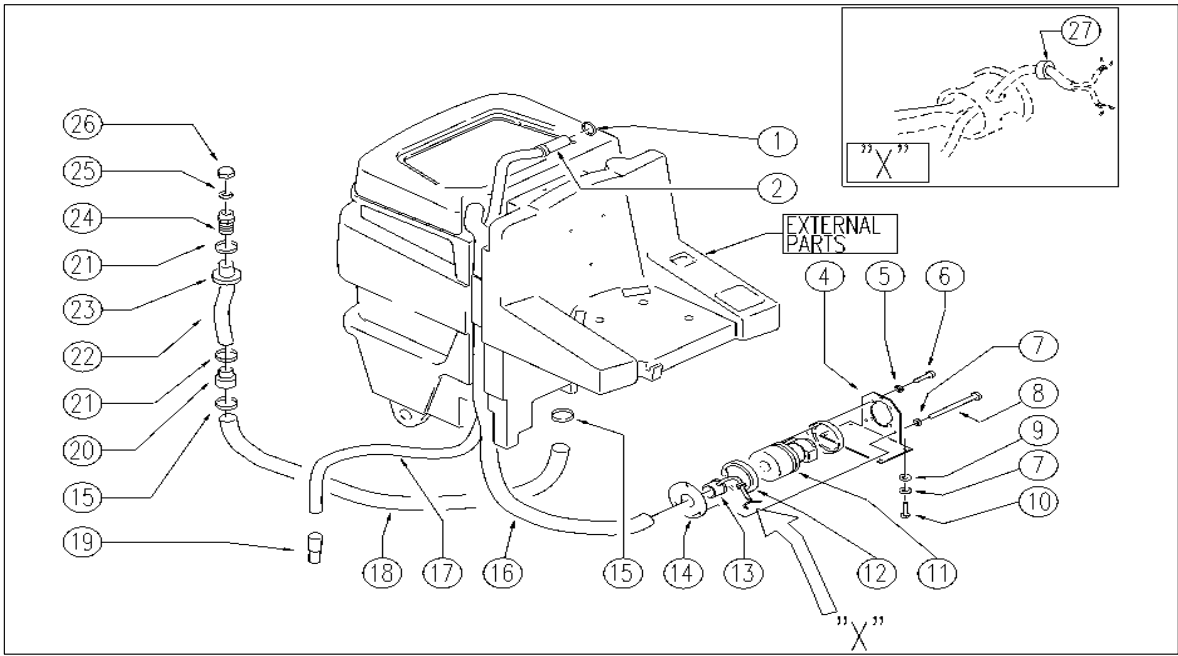

REF.	CODE	DESCRIPTION	QT
1	E89074	Gasket for WS36	1
2	E89470	Sleeve	1
4	SL09684	SUPPORT	1
5	E86707	Cham Washer D10	4
6	SL04223	SCREW	4
7	E86700	Cham Washer D6	7
8	SL04247	SCREW	3
9	E86704	Washer D 6-18	4
10	E86366	screw WS20	4
11	E86805	Vacuum Motor	1
12	E86612	Gasket	2
13	SL17565	CONNECTOR	1
14	SL09685	FLANGE	1
15	E86557	clamp AS30/36	2
16	E86948	Hose	1
17	E86848	Vacuum Hose	1
18	E86866	Recovery Hose	1
19	E86849	Sleeve	1
20	E86965	Connector	1
21	SL14079	CLAMP	2
22	E86962	Sheath, Drain Hose	1
23	E86961	Adapter, Drain Hose	1
24	E86966	Hose Holder	1
25	E86968	Gasket	1
26	E86967	Cap	1
27	E89273	Fairlead	1

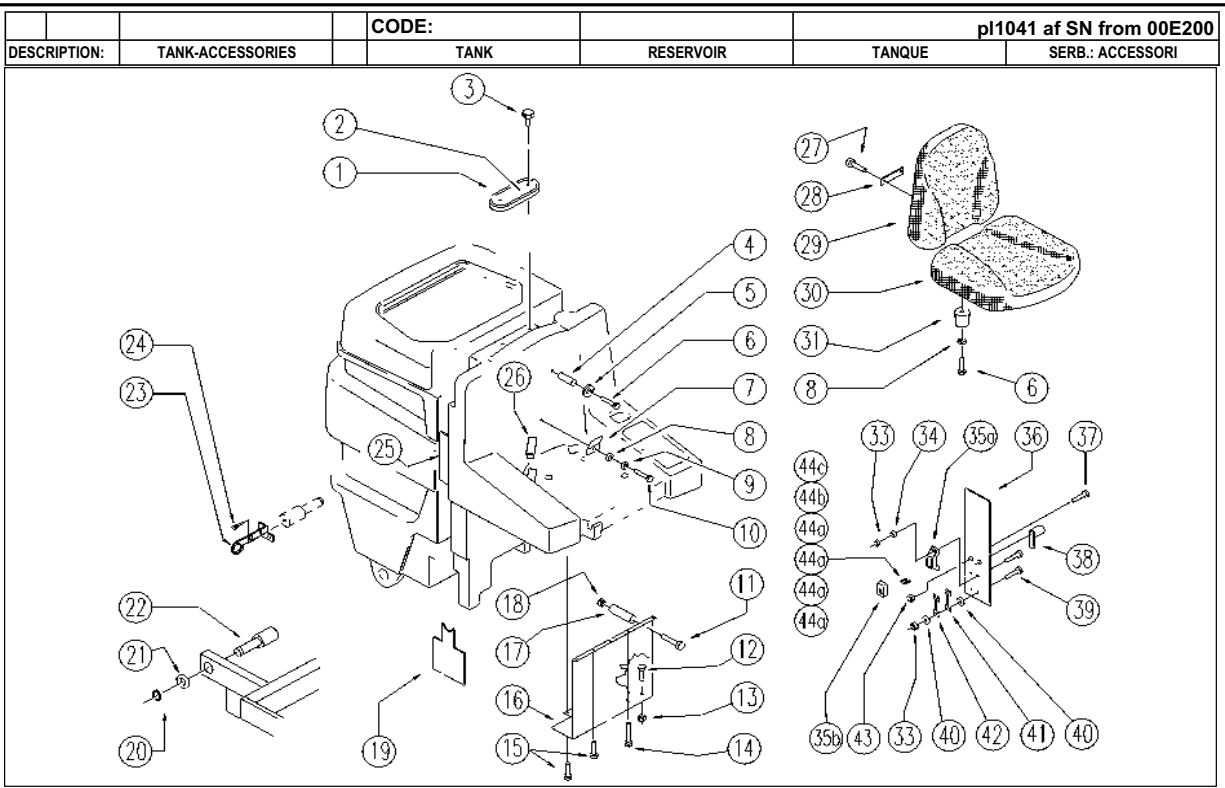

REF.	CODE	DESCRIPTION	QT
1	SL03275	GASKET	1
2	E86974	Sifter Room Cover	1
3	SL20055	HANDWHEEL	2
4	SL07293	SPACER	2
5	E86704	Washer D 6-18	2
6	E86708	Screw TE M 6-35	6
7	SL09540	PLATE	1
8	E86707	Cham Washer D10	4
9	E86700	Cham Washer D6	1
10	SL04180	SCREW	1
11	SL04196	SCREW	1
12	SL04252	SCREW	1
13	E86853	Nyloc Hex Nut, M8	1
14	SL04223	SCREW	2
15	E89276	Screw	7
16	SL09694	PLATE	1
17	SL07337	SPACER	1
18	E86552	nut	1
19	SL17499-2	PANEL	1
20	SL11108	RING	2
21	SL06080	WASHER	2
22	SL07301	PIN	2
23	SL09962	SUPPORT	1
24	SL04294	SCREW	1
25	SL17395	REINFORCEMENT	1
26	SL14199	TERMINAL	2
27	E86901	AS30/36 Seat Back Screw	1
28	E86902	Seat Anchorage Plate	1
29	SL14191-F	SEAT BACK	1
30	SL14190-F	SEAT	1
31	SL03103	PLUG/STOPPER	4
33	SL05012	NUT	4
34	E86750	Washer D5	2
36	SL09901	LID	1
37	SL04161	SCREW	1
38	SL20045	CATCH/LOCK	1
39	E89469	M4 - 15 Screw	4
40	E89118	Washer	4
41	E86836	Fuse 100 amp	1
42	E86643	Fuse 75 amp	1
43	E86875	Self-Locking Nut	1
35a	SL23894	FUSE-HOLDERS	1
35b	SL23893-2	LID	1
44a	E86825	Fuse 5 amp	4
44b	E86827	Fuse 25 amp	1
44c	E86826	Fuse 15 amp	1

		<b>CODE:</b>	pl1044 aa SN from 96D673		
<b>DESCRIPTION:</b>	STEERING COLUMN	LENKSÄULE	BARRE / TUBE	COLUMNA DE DIRECCIÓN	PIANTONE

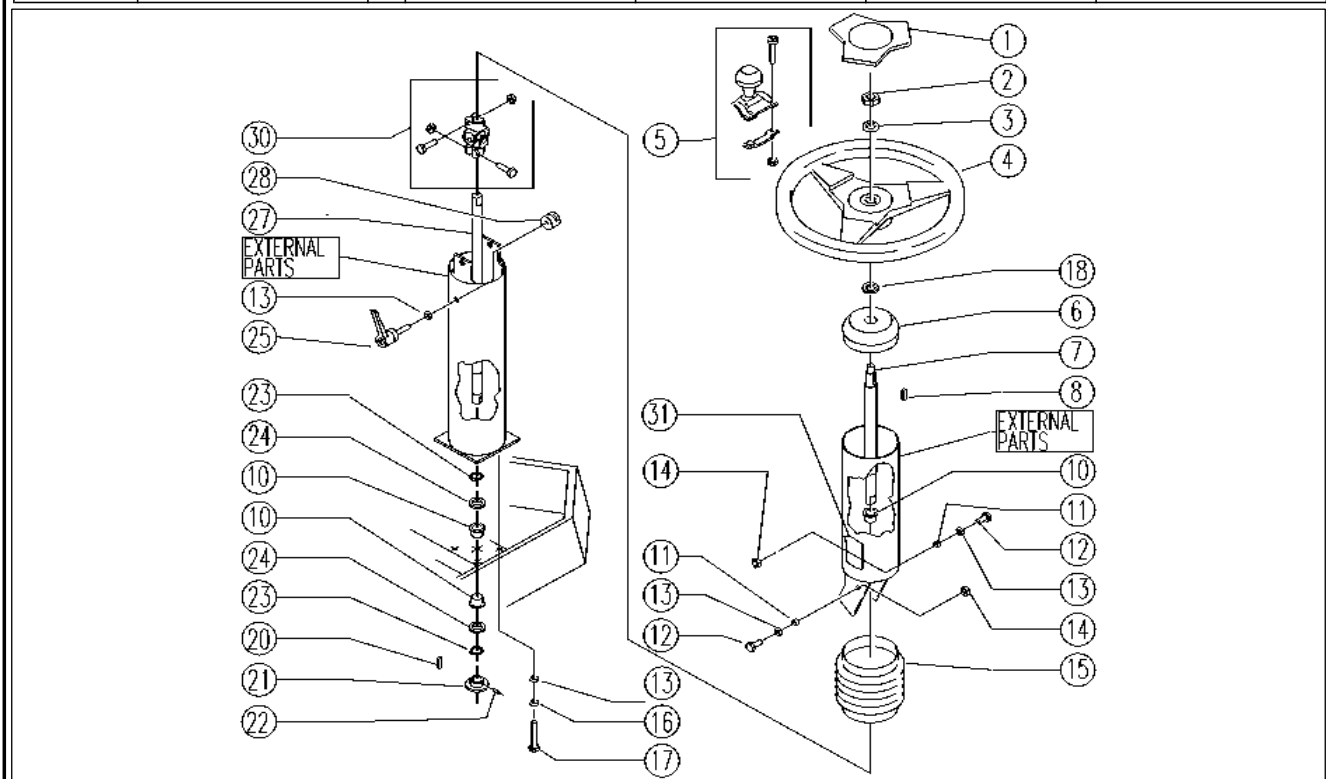

REF.	CODE	DESCRIPTION	QT
1	SL14194	CAP	1
2	SL05037	NUT	1
3	SL06029	WASHER	1
4	SL14195	STEERING WHEEL	1
5	E86953	Knob, Steering Wheel	1
6	SL07268	CAP	1
7	SL07260	SHAFT	1
8	E86536	Key	1
10	E89268	Bushing	3
11	SL07062	SPACER	2
12	SL04023	SCREW	2
13	E86726	Washer	7
14	E86853	Nyloc Hex Nut, M8 Zinc	2
15	E89109	boot cover WS36	1
16	E86702	Cham Washer D8	4
17	E86870	Screw	4
18	SL06096	WASHER	1
20	E89199	Key 5-5-15	1
21	SL10056	PINION	1
22	SL11048	GRAIN	1
23	SL11094	RING	2
24	SL06074	WASHER	2
25	E86920	AS30/36 Lever	1
27	SL07259	SHAFT	1
28	E89444	Lock	1
30	SL12023	JOINT	1
31	SL25559	LABEL	1

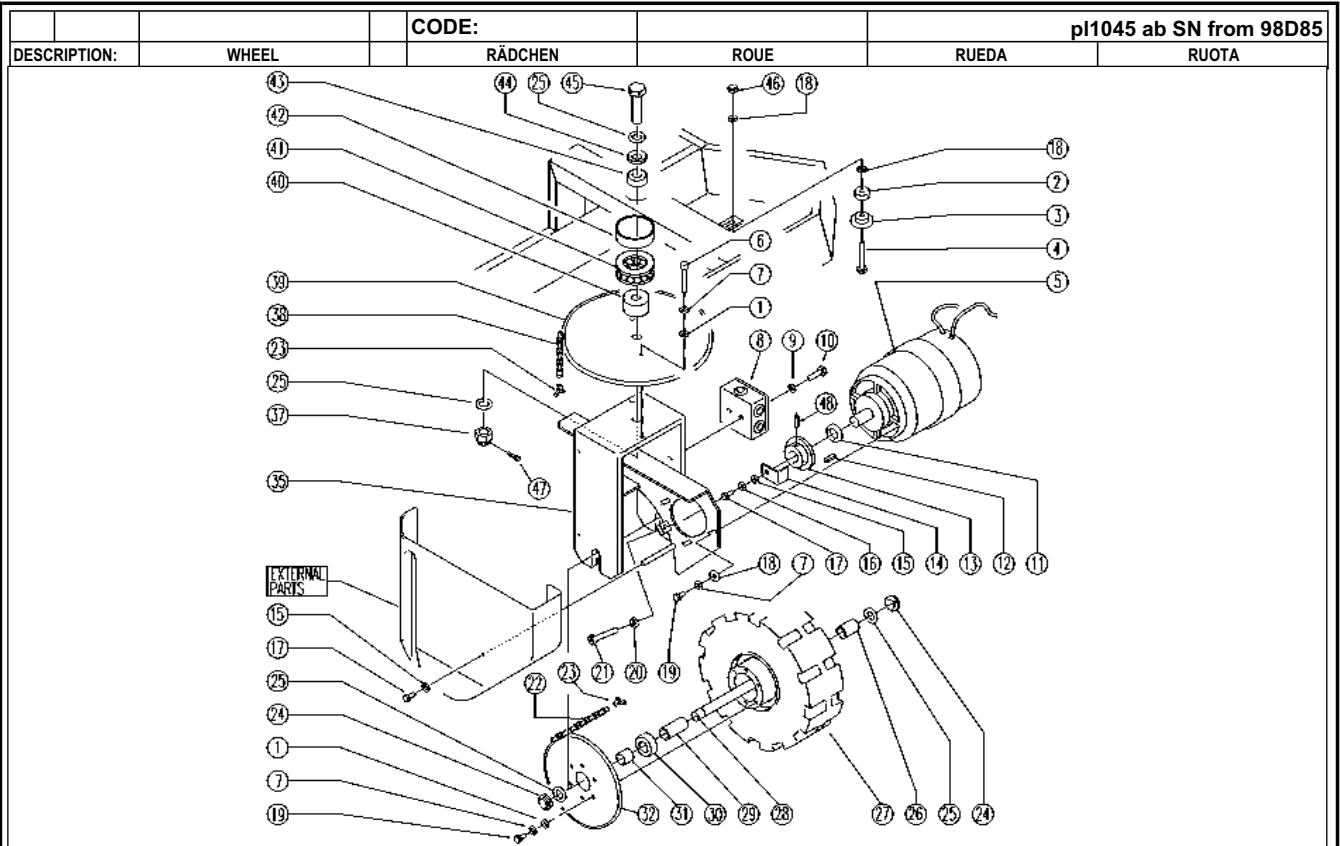

REF.	CODE	DESCRIPTION	QT
1	E86726	WASHER	14
2	E86356	SPACER	1
3	E86357	CHAIN TIGHTENER	1
4	E86486	SCREW	1
5	SL02112	GEARMOTOR	1
6	SL04192	SCREW	2
7	E86702	WASHER	12
8	SL23468	ELECT. HOUSING	1
9	E86797	WASHER	2
10	E86336	SCREW	2
11	SL06066	WASHER	1
12	SL11110	TONGUE	1
13	E86972	PINION	1
14	SL09706	PLATE	1
15	E86707	WASHER	4
16	E86700	WASHER	1
17	E86366	SCREW	3
18	E86979	WASHER	5
19	SL04023	SCREW	10
20	E86703	NUT	1
21	E86870	SCREW	1
22	E86986	CHAIN	1
23	E86987	GRID	2
24	E86854	NUT	2
25	E86855	WASHER	4
26	E86856	SPACER	1
27	E86984	WHEEL	1
28	E86857	PIN	1
29	E86858	SPACER	1
30	E86817	BEARING	1
31	E86859	SPACER	1
32	E86991	CROWN	1
35	SL09687	FORK	1
37	SL05079	NUT	1
38	E87809	CHAIN	1
39	SL10034	CROWN	1
40	SL07096	SPACER	1
41	SL12014	BEARING	1
42	SL03461	GUARD	1
43	E86814	BEARING	1
44	SL12021	RING	1
45	SL07450	SCREW	1
46	E86853	NUT	1
47	SL11121	SPLIT PIN	1
48	SL11048	SPLIT PIN	1
-	SL07258	MOTOR DRUM	1

		<b>CODE:</b>	<b>pl1047 ac SN from 97F758</b>		
<b>DESCRIPTION:</b>	<b>REAR HEAD LIFT</b>	<b>KOPFHEBEVORRICHTUNG</b>	<b>SOULEVEMENT TETE</b>	<b>LEVANTAMIENTO CABEZA</b>	<b>SOLL. POSTERIORE TESTATA</b>

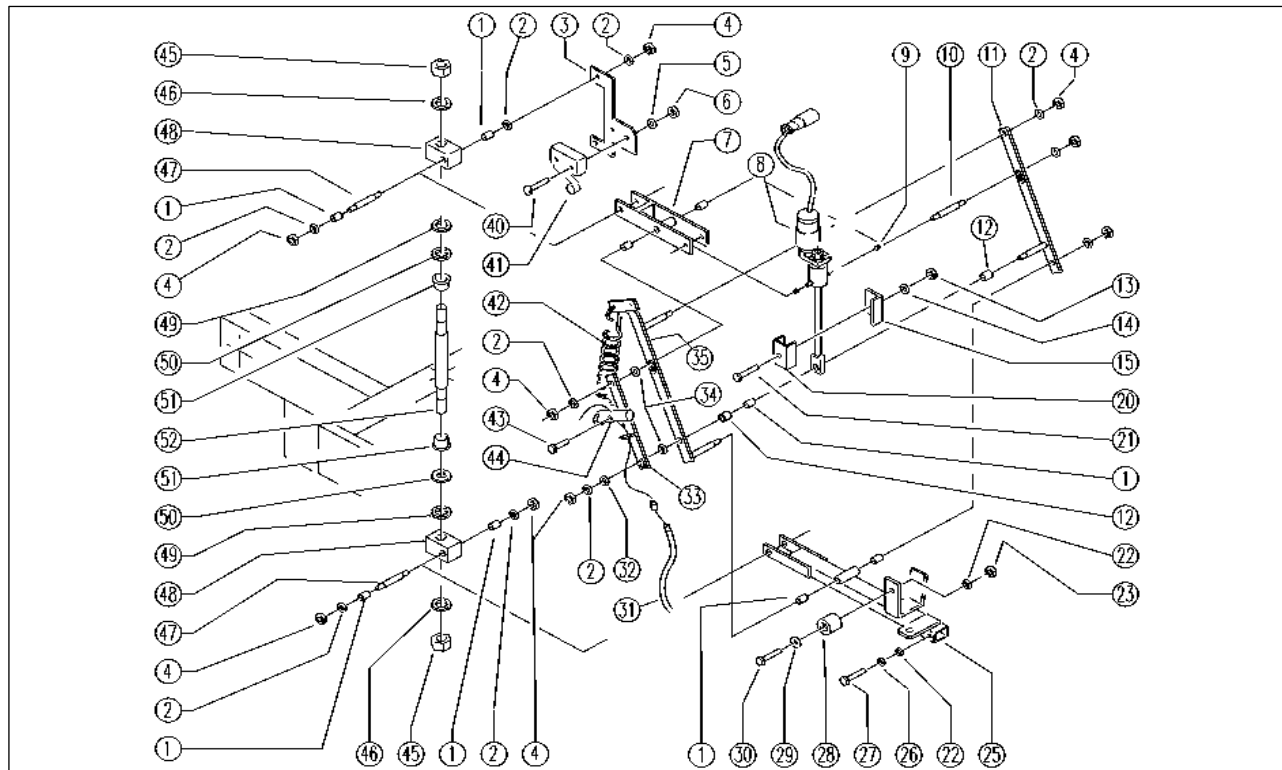

REF.	CODE	DESCRIPTION	QT
1	E89442	Bearing	9
2	E86726	Washer	10
3	SL09852	SUPPORT	1
4	E86853	Nyloc Hex Nut, M8 Zinc	10
5	E86797	Washer	2
6	E86739	AS28 Nut	2
7	SL09520	LEVER	1
8	E86801	Actuator	1
9	E89441	Bearing	2
10	E89450	Pin	1
11	SL09736	LEVER	1
12	E89443	Spacer	2
13	SL05007	NUT	1
14	SL06016	WASHER	1
15	SL09734	SUPPORT	1
20	SL09743	SPACER	1
21	SL04013	SCREW	1
22	E86707	Cham Washer D10	3
23	E87868	Self Locking Nut	1
25	SL09519	LEVER	1
26	E86700	Cham Washer D6	2
27	E89486	Screw	2
28	SL03103	CAP	1
29	E86758	Washer	1
30	E86705	Screw TE M 6-30	1
31	SL14225	CABLE	1
32	E86881	Washer	1
33	SL09749	PLATE	1
34	E86980	Washer D13-24-2.5	2
35	SL09735	PLATE	1
40	SL04107	SCREW	2
41	E86828	Microswitch	1
42	E86937	AS36 Spring	2
43	SL04180	SCREW	1
44	SL07314	PIN	1
45	SL05037	NUT	2
46	SL06029	WASHER	2
47	SL07272	PIN	2
48	SL07274	BLOCK / LOCK	2
49	E86855	Washer	2
50	SL06074	WASHER	2
51	E89268	Bushing	2
52	SL07273	PIN	1

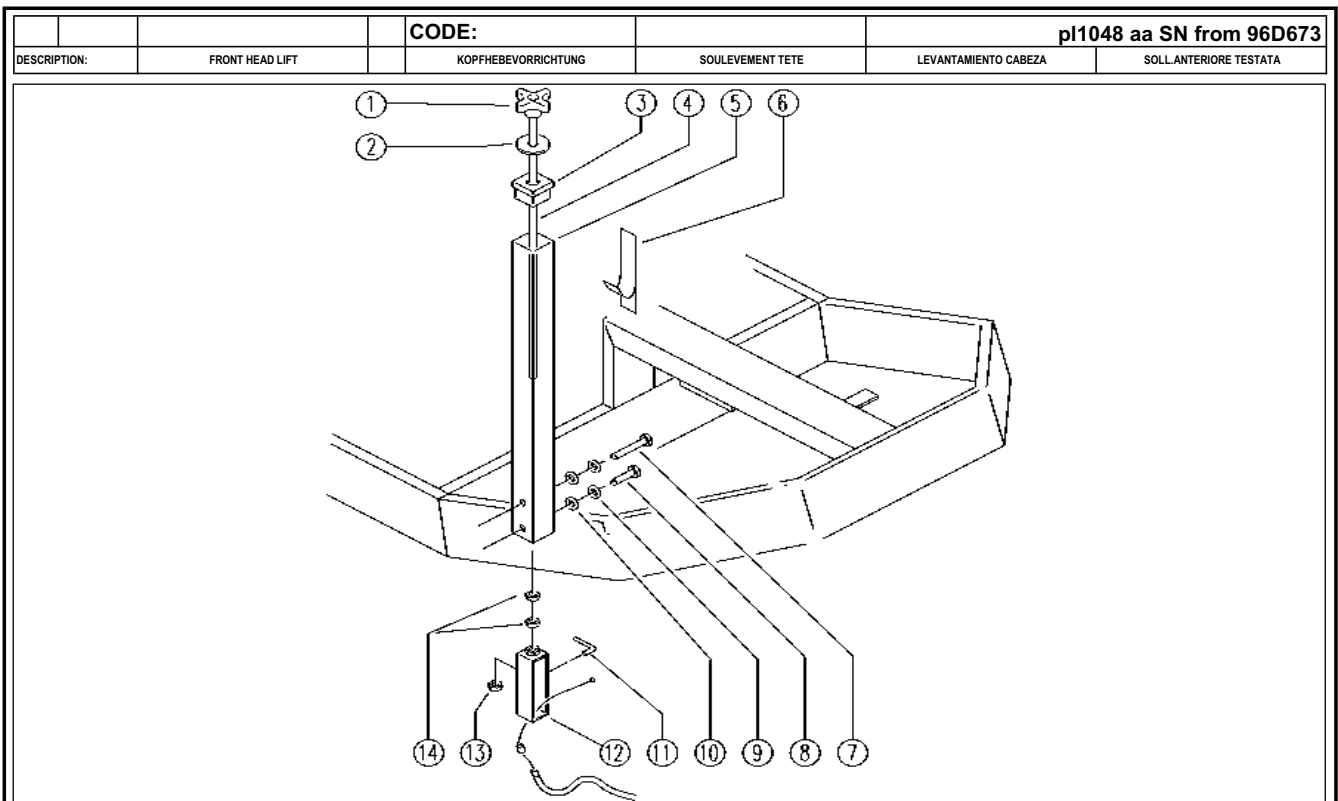

REF.	CODE	DESCRIPTION	QT
1	E86852	Squeegee Knob AS30/36	1
2	E86588	washer FS28/32	1
3	SL14308	CAP	1
4	SL04287	BAR	1
5	SL09746	STRUCTURAL	1
6	SL25903	ADESIVE LABEL	1
7	SL04019	SCREW	1
8	SL04023	SCREW	1
9	E86702	Cham Washer D8	2
10	E86726	Washer	2
11	SL07316	INDICATOR	1
12	SL09747	PLATE	1
13	E86853	Nyloc Hex Nut, M8 Zinc	1
14	E86703	Nut M8	2

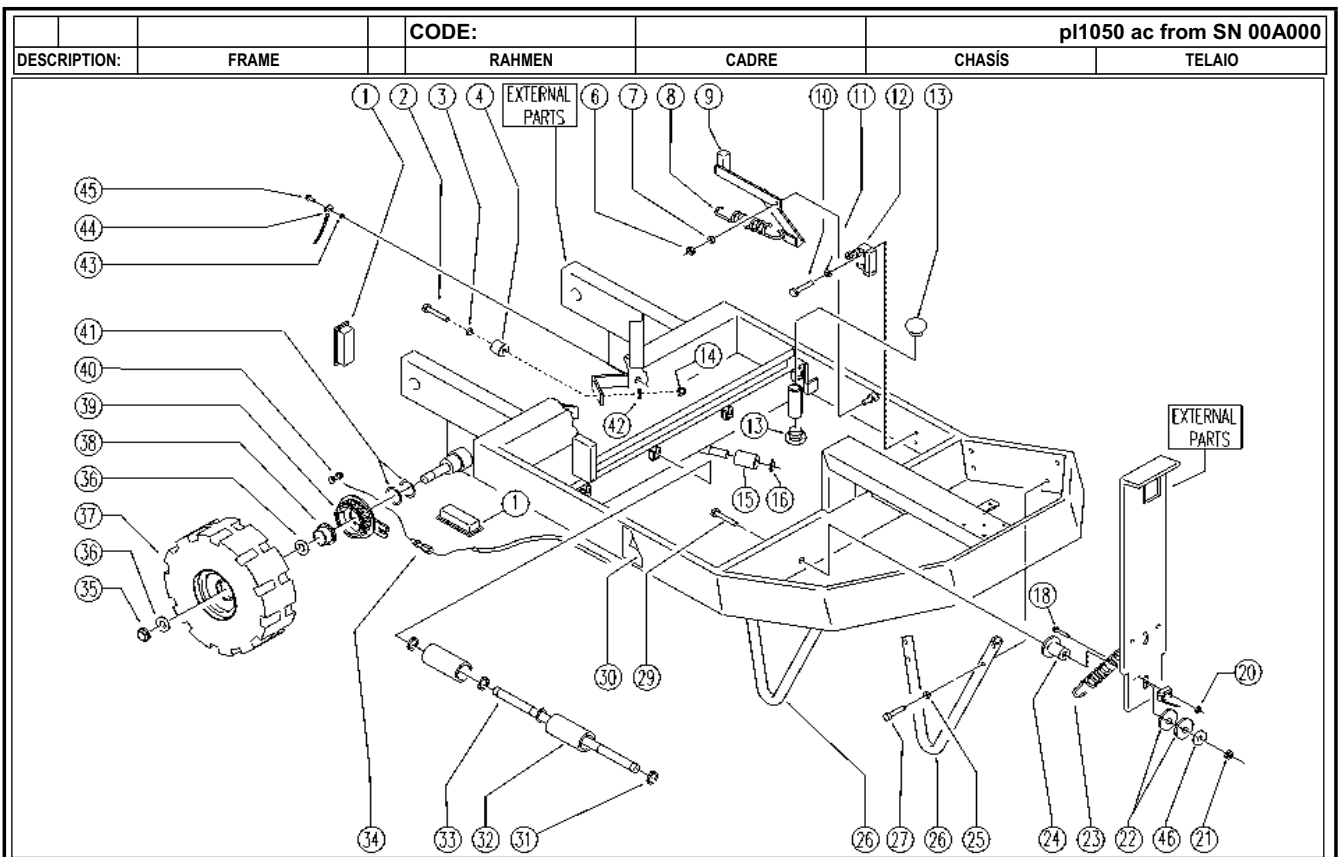

REF.	CODE	DESCRIPTION	QT
1	SL14198	TERMINAL	4
2	E86705	Screw TE M 6-30	2
3	E86758	Washer	2
4	SL03103	PLUG / STOPPER	2
6	E86853	Nyloc Hex Nut, M8 Zinc	1
7	E86726	Washer	1
8	E88578	Spring	1
9	SL09698	LEVER	1
10	SL04107	SCREW	2
11	E86797	Washer	2
12	E86828	Microswitch	1
13	SL14217	PLUG	6
14	E86552	nut	2
15	SL07325	ROLLER	1
16	SL11021	SEEGER	1
18	E89145	Screw	2
20	E89146	Nut	1
21	E86853	Nyloc Hex Nut, M8 Zinc	1
22	E86492	AS20 Washer	2
23	SL13013	SPRING	2
24	SL07371	SPACER	1
25	E86702	Cham Washer D8	8
26	SL39012	HOSE	2
27	E87863	Screw WS20/24	8
29	E86542	Screw AS20	1
30	SL25602	LABEL	1
31	E86537	Ring	16
32	SL07351	ROLLER	8
33	SL07300	PIN	4
34	SL14222	REGISTER	2
35	E86854	Nut	2
36	E86855	Washer	4
37	SL08030	WHEEL	2
38	E87941	Bushing, flange	2
39	SL14192	BLOCK	2
40	SL14031	CLAMP	2
41	SL06075	WASHER	4
42	E86707	Cham Washer D10	2
43	E89119	Washer	1
44	SL23593	CABLE	1
45	E86706	Screw TE M 6-16	1
46	E89202	Washer	1

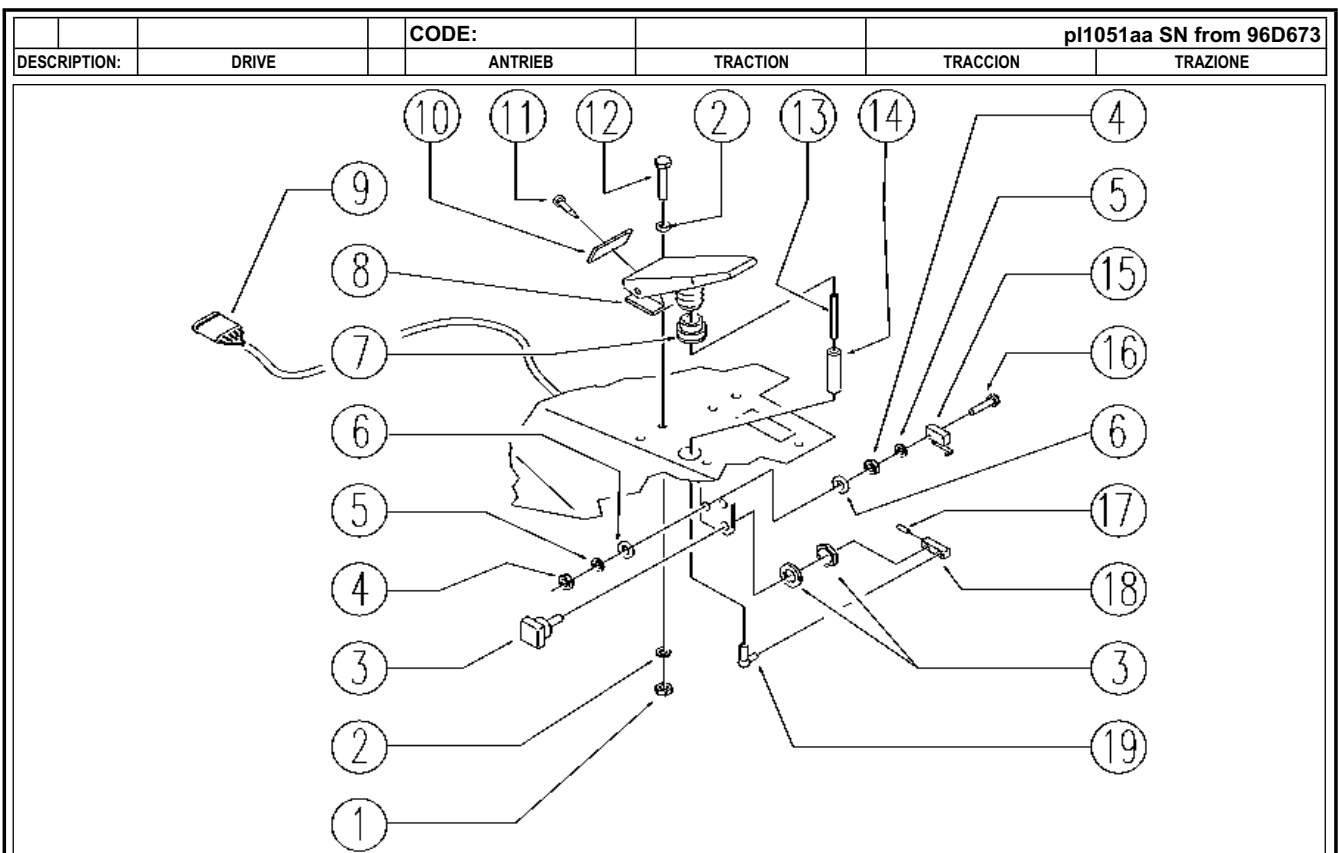

REF.	CODE	DESCRIPTION	QT
1	E86552	NUT	2
2	E86707	WASHER	4
3	E86824	POTENTIOMETER	1
4	E89274	NUT	4
5	E89275	WASHER	4
6	E86797	WASHER	4
7	E86364	BUSHING	1
8	E89269	TREADLE	1
9	SL23928	WIRING	1
10	E89270	SPACER	1
11	E89276	SCREW	1
12	E89486	SCREW	2
13	E89277	BAR	1
14	E89209	SPACER	1
15	E86823	MICROSWITCH	1
16	E86597	SCREW	2
17	E87839	SPLIT PIN	1
18	E86760	LEVER	1
19	E87840	ARTICULATION	1

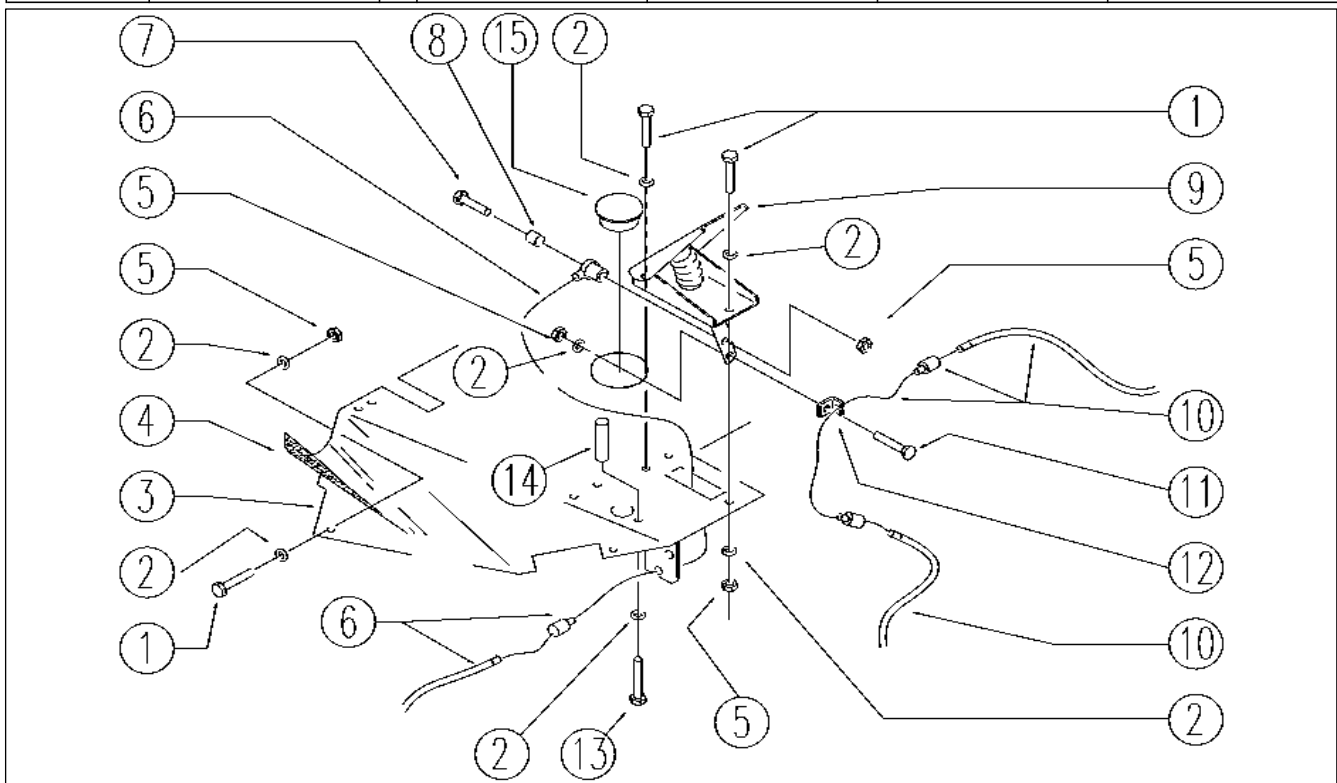

REF.	CODE	DESCRIPTION	QT
1	E89486	Screw	10
2	E86707	Cham Washer D10	22
3	SL09824	FOOTBOARD	1
4	SL03242	COVERING / COATING	1
5	E86552	nut	12
6	SL14210	CABLE	1
7	E86366	screw WS20	1
8	E87909	Spacer	1
9	SL22011	TREADLE	1
10	SL14216	CABLE	1
11	E86901	Seat Back Screw	1
12	SL09723	BLOCK / LOCK	1
13	E86366	screw WS20	1
14	SL07333	SPACER	1
15	E89132	Cap	1

DESCRIPTION:	HAND BRAKE	CODE:	BREMSE	FREIN	FRENO	FRENO A MANO
--------------	------------	-------	--------	-------	-------	--------------

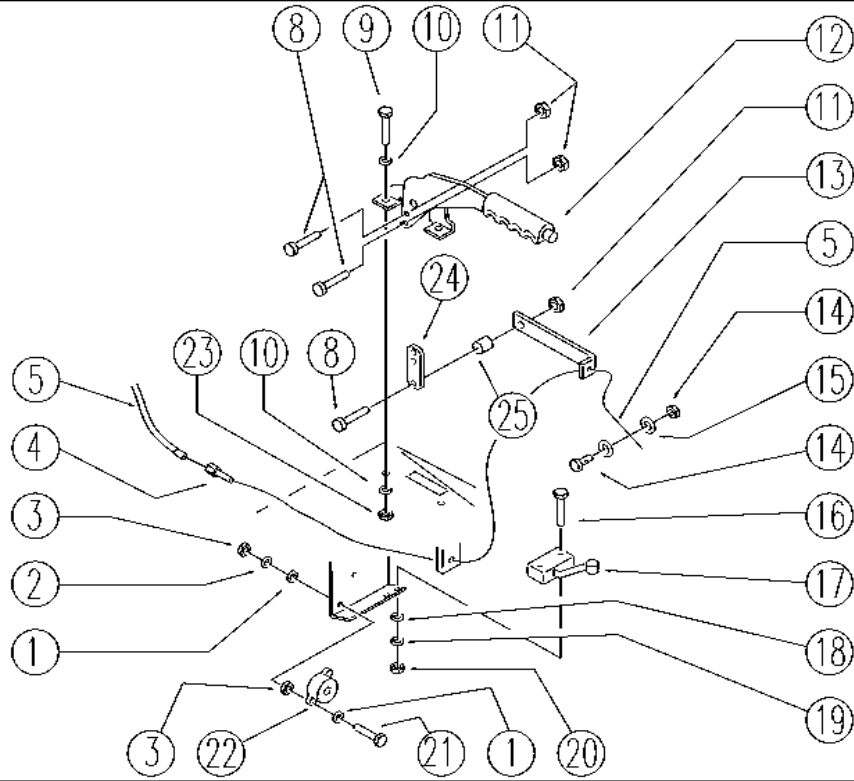

REF.	CODE	DESCRIPTION	QT
1	SL06009	WASHER	4
2	E89275	Washer	2
3	E89274	Nut	4
4	SL14222	REGISTER	1
5	SL14210	CABLE	1
8	SL04023	SCREW	3
9	E89486	Screw	2
10	E86707	Cham Washer D10	4
11	E86853	Nyloc Hex Nut, M8 Zinc	3
12	SL20042	LEVER	1
13	SL09731	SMALL BRACKET	1
14	SL14212	CLAMP	1
15	E88091	Washer	2
16	SL04197	SCREW	2
17	E86828	Microswitch	1
18	E86797	Washer	2
19	E86769	Washer	2
20	SL05012	NUT	2
21	E86597	screw	2
22	SL23354	INDICATOR	1
23	E86552	nut	2
24	SL09722	BLOCK / LOCK	1
25	SL07062	SCREW	1

		CODE:	pl1058 aa SN from 96D673		
DESCRIPTION:	BOX	BEHÄLTER	CAISSON	CAJA	CASSONE BATTERIE

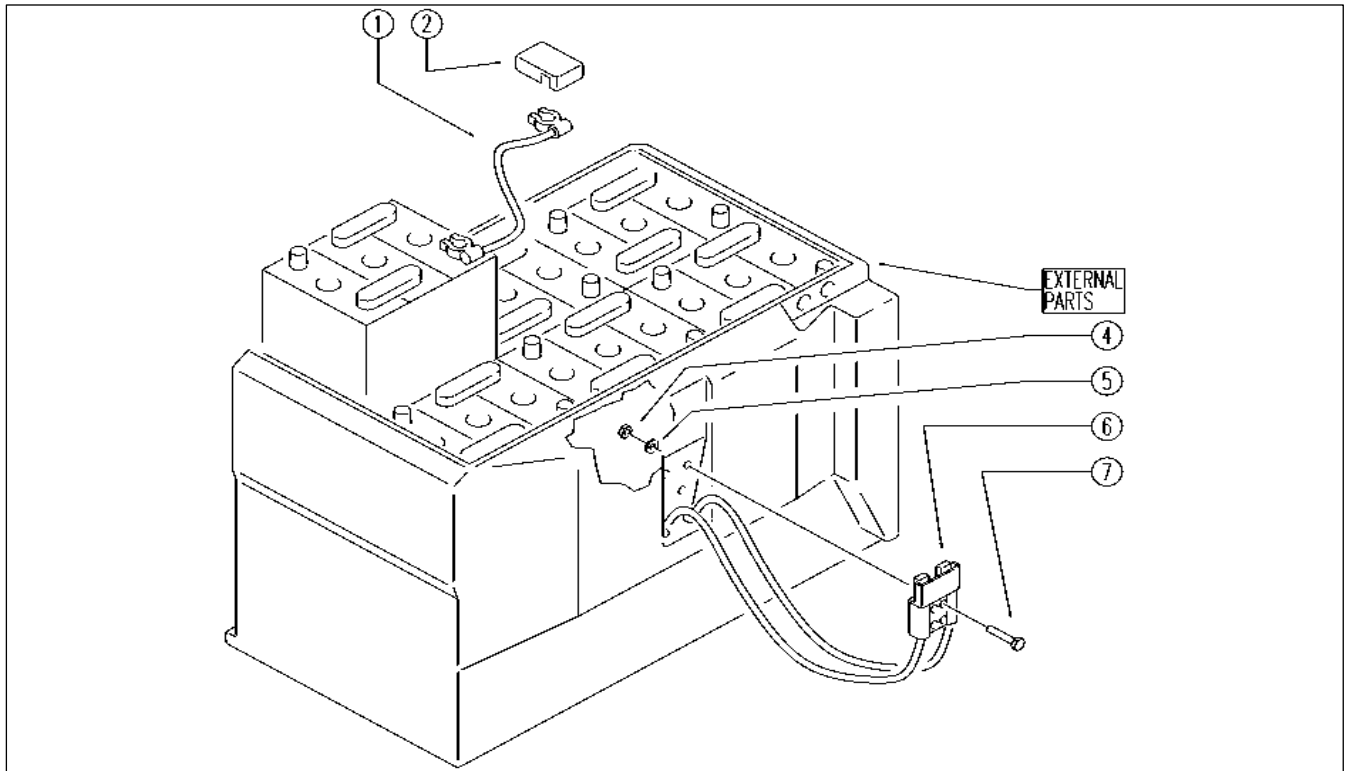

REF.	CODE	DESCRIPTION	QT
1	SL23940	BRIDGE / JUMPER	5
2	E86443	Cable Covers	12
4	E86552	nut	4
5	E86707	Cham Washer D10	4
6	E89221	Wiring	1
7	E86708	Screw TE M 6-35	4

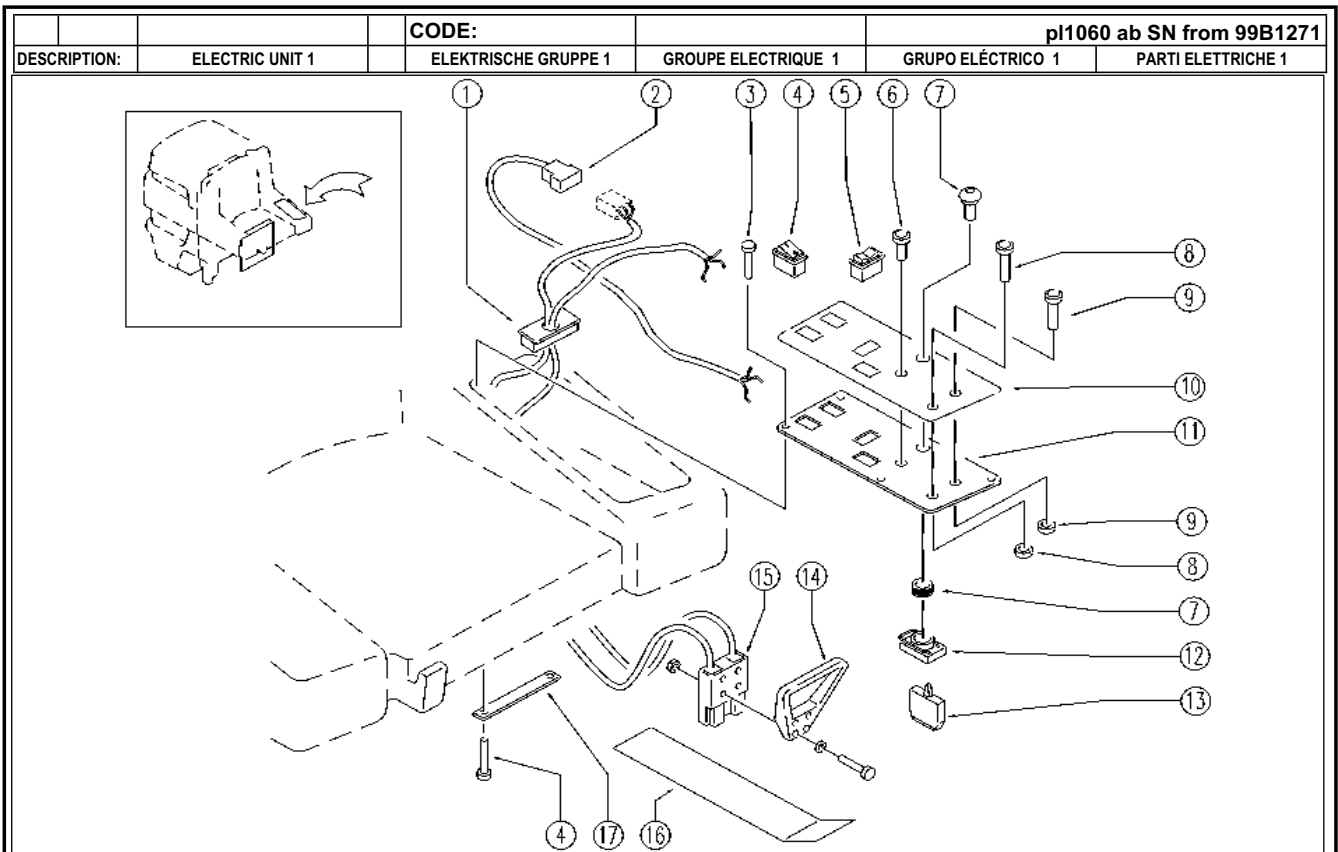

REF.	CODICE	DESCRIPTION	QT
1	SL14230	TERMINAL	1
2	SL23478	WIRING	1
3	SL04223	SCREW	10
4	E86423	Bipolar Switch	2
5	E87805	Switch FS28	2
6	SL23024	PILOT LIGHT	1
7	E86988	Operator D22 Mushroom	1
7	E86909	AS30/36 Reverse Switch	1
8	E86909	AS30/36 Reverse Switch	1
8	E88116	Push Button Horn	1
9	E86909	AS30/36 Reverse Switch	1
9	E88116	Push Button Horn	1
9	E88116	Push Button Horn	1
9	E88116	Push Button Horn	1
10	SL25784	ADESIVE LABEL	1
11	SL09952	PLATE	1
12	E86988	Operator D22	1
13	E86988	Operator D22	2
14	E86947	Handle Plug, Anderson	1
15	E86946	Anderson Plug, 160 AC	1
16	SL09917	PLATE	1
17	SL09526	SUPPORT	3

		<b>CODE:</b>	pl1061 ac SN from 99B1272		
<b>DESCRIPTION:</b>	ELECTRIC UNIT 2	ELEKTRISCHE GRUPPE 2	GRUPE ELECTRIQUE 2	GRUPO ELÉCTRICO 2	PARTI ELETTRICHE 2

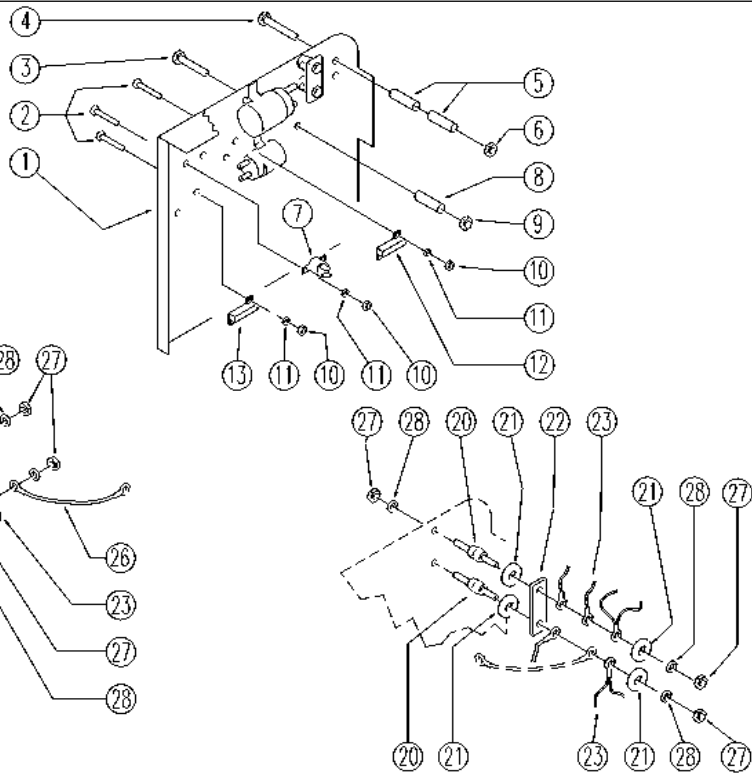
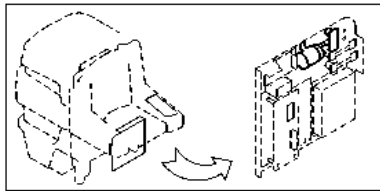

REF.	CODICE	DESCRIPTION	QT
1	SL09682	PLATE	1
2	SL04179	SCREW	8
3	SL04047	SCREW	1
4	SL04196	SCREW	2
5	SL07176	SPACER	4
6	E87868	Self Locking Nut	6
7	E87899	thermostat AS36	2
8	SL07337	SPACER	1
9	E86853	Nyloc Hex Nut, M8 Zinc	1
10	E88225	Nut	8
11	SL06009	WASHER	8
12	SL23969	RESISTANCE	1
13	E89433	Resistor AS30/36	1
15	E86707	Cham Washer D10	4
20	E86563	support	2
21	E86878	Washer	4
22	SL23569	BRIDGE / JUMPER	1
23	GR23479	WIRING UNIT	1
26	SL23125	SHUNT	1
27	E86703	Nut M8	12
28	E86702	Cham Washer D8	12
29	SL23034	TELESWITCH	1
30	E86706	Screw TE M 6-16	4
31	E86829	Remote Control	1

		<b>CODE:</b>	pl1062 ac SN from 99B1272		
<b>DESCRIPTION:</b>	ELECTRIC UNIT 3	ELEKTRISCHE GRUPPE 3	GRUPE ELECTRIQUE 3	GRUPO ELÉCTRICO 3	ELECTRIC UNIT 3

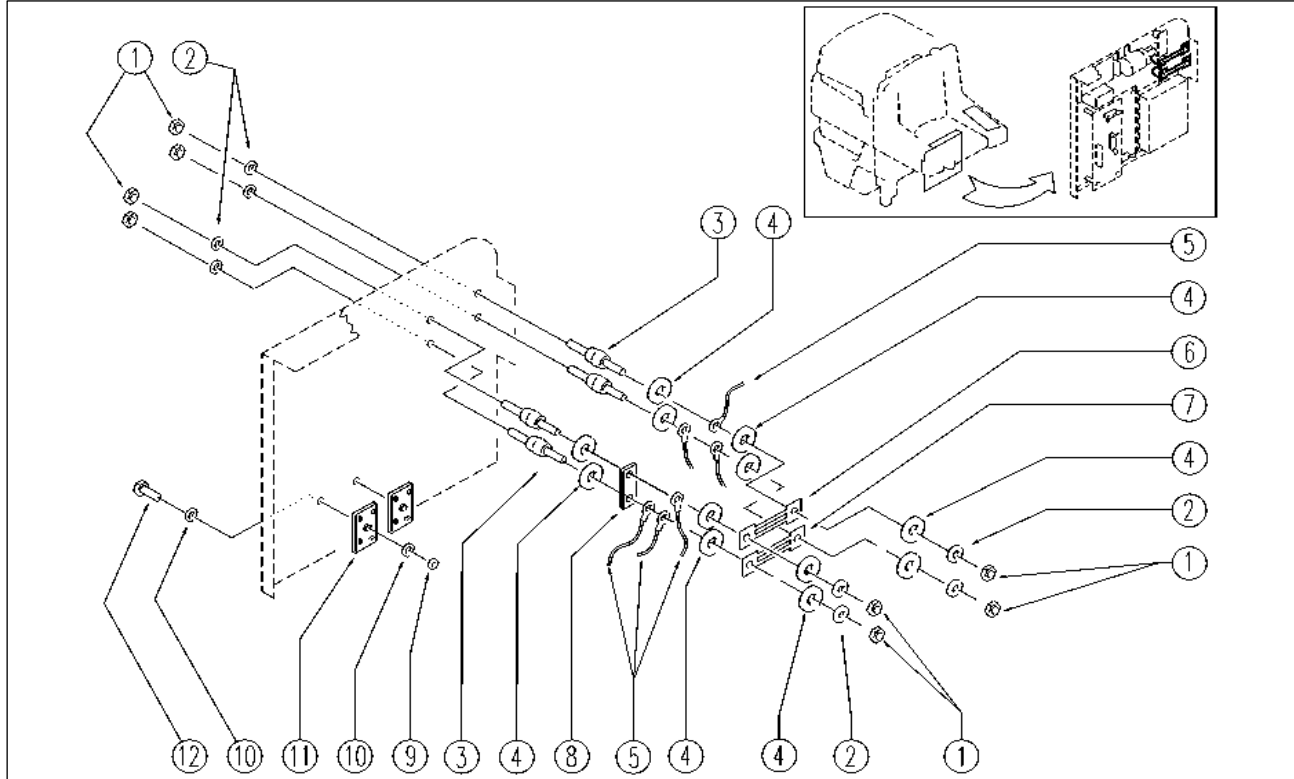

REF.	CODE	DESCRIPTION	QT
1	E86703	Nut M8	8
2	E86702	Cham Washer D8	8
3	E86563	support	4
4	E86878	Washer	12
5	GR23479	WIRING	1
6	E86643	Fuse 75 amp	1
7	E86836	Fuse 100 amp	1
8	SL23569	BRIDGE / JUMPER	1
9	E86739	AS28 Nut	2
10	E86797	Washer	4
11	E89088	Rectifier	2
12	SL04088	SCREW	2

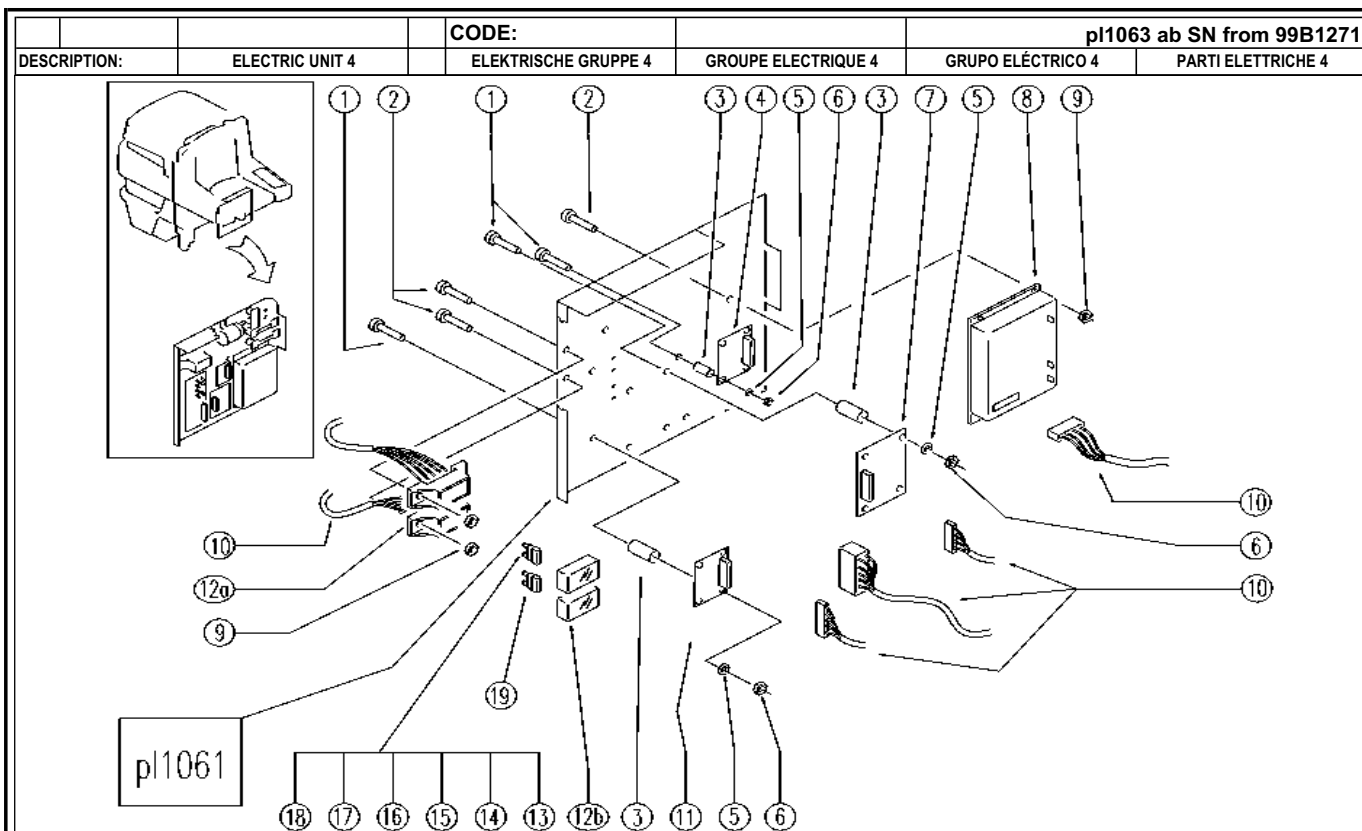

REF.	CODE	DESCRIPTION	QT
1	E86597	screw	12
2	E86903	Screw M.4-16	8
3	SL14184	SPACER	12
4	E87901	Board	1
5	SL06009	WASHER	12
6	E89274	Nut	12
7	E86834	Auxiliary Card	1
8	E86838	Traction Card	1
9	E86739	AS28 Nut	8
10	GR23479-2	WIRING UNIT	2
11	SL23039	BOARD	1
12a	E89468	Fuse Carrier	2
12b	SL23893-2	LID	2
13	E86825	Fuse 5 amp	1
14	E86825	Fuse 5 amp	1
15	E86825	Fuse 5 amp	1
16	E86825	Fuse 5 amp	1
17	E86827	Fuse 25 amp	1
18	E86826	Fuse 15 amp	1
19	E86825	Fuse 5 amp	1

		CODE:			
DESCRIPTION:	SQUEEGEE PEDAL	PEDAL	PEDALE SQUEEGEE	PEDAL SQUEEGEE	PEDALE SQUEEGEE

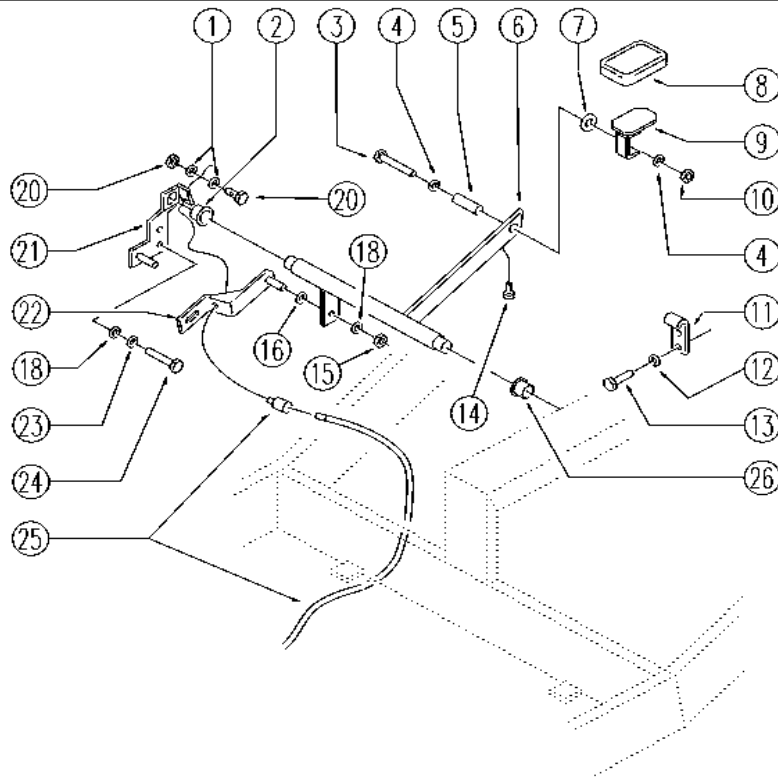

REF.	CODE	DESCRIPTION	QT
1	E88091	Washer	2
2	E89268	Bushing	1
3	E86705	Screw TE M 6-30	1
4	E86707	Cham Washer D10	2
5	E89278	Spacer	1
6	SL09738	LEVER	1
7	E89279	Washer	1
8	E89419	Rubber Shim	1
9	SL09741	TREADLE	1
10	E86875	Self-Locking Nut	1
11	SL09740	BLOCK	1
12	SL06016	WASHER	2
13	SL04223	SCREW	2
14	SL14309	RUBBER	1
15	E86853	Nyloc Hex Nut, M8 Zinc	1
16	E86881	Washer	1
18	E86726	Washer	3
20	SL14212	CLAMP	1
21	E86851	Plate	1
22	E87878	Plate AS36/WS36T	1
23	E86702	Cham Washer D8	2
24	E89194	Screw	2
25	E86818	Squeegee Wire Lift	1
26	E89403	Bushing	1

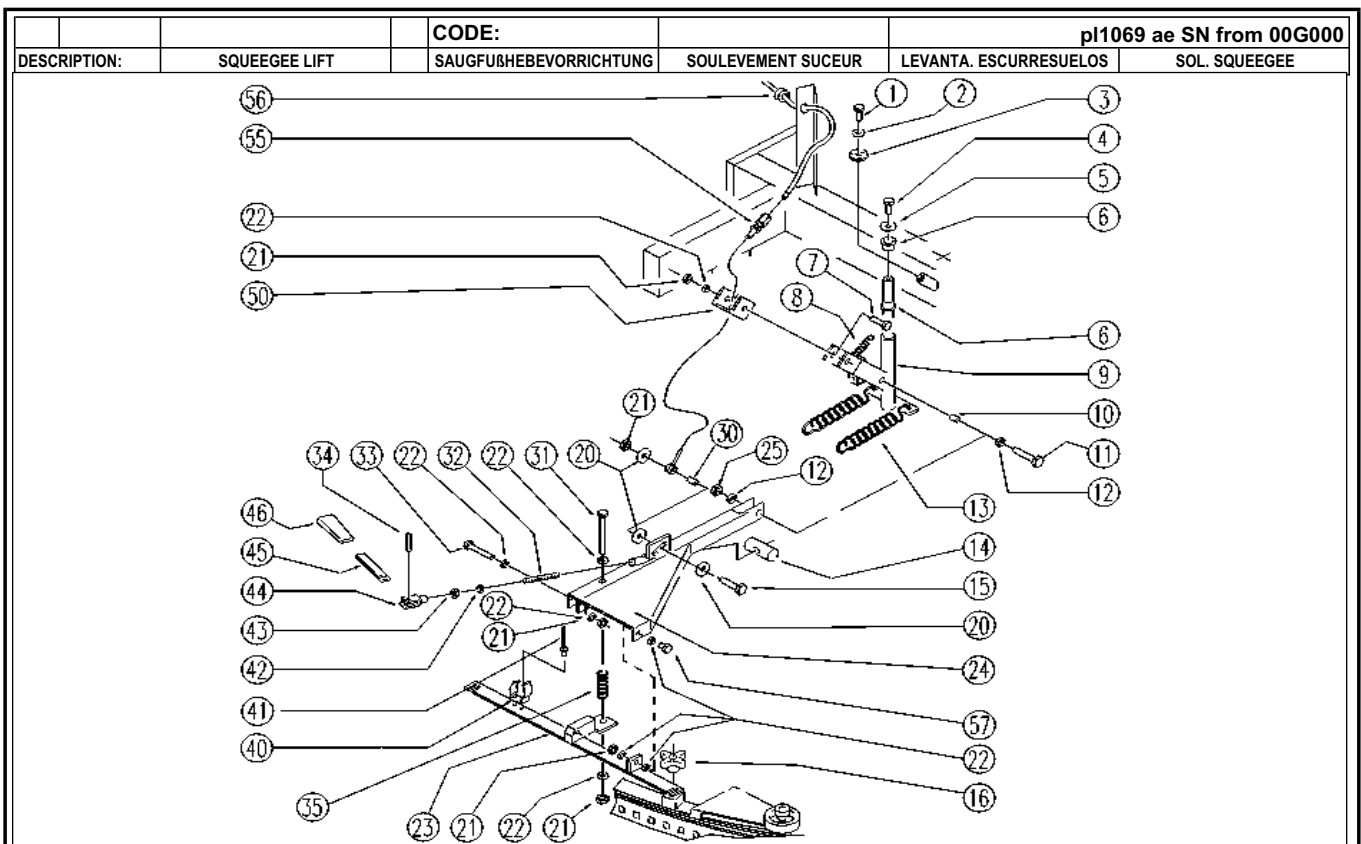

REF.	CODE	DESCRIPTION	QT
1	SL04180	SCREW	1
2	E86758	Washer	1
3	SL06092	WASHER	1
4	E86706	Screw TE M 6-16	1
5	E89202	Washer	1
6	E89403	Bushing	2
7	E89194	Screw	2
8	E86363	spring AS36/WS36	1
9	E86847	Clip	1
10	E89442	Bearing	2
11	SL04312	SCREW	1
12	E88091	Washer Watchman 24	2
13	SL13065	SPRING	2
14	SL09537	HOOKING	1
15	E89464	Screw	1
16	E86852	Squeegee Knob AS30/36	2
20	E86878	Washer	3
21	E86853	Nyloc Hex Nut, M8 Zinc	5
22	E86879	Washer	8
23	E86845	Bracket, Squeegee	1
24	E86846	Lever, Squeegee	1
25	E86462	AS20 Nut	1
30	SL07493	SPACER	1
31	E86872	Screw	1
32	E86319	shaft WS20	1
33	E86486	Screw TE M8-45	1
34	E89204	Pin WS36	1
35	E89495	Spring	1
40	SL13014	CLIP	1
41	SL14006	TEAR RIVET	2
42	SL06018	WASHER	1
43	E86703	Nut M8	1
44	E86917	AS30/36 Fork	1
45	E89205	Lever WS36	1
46	E86450	Tank Support Handle	1
50	SL09737	SUPPORT	1
55	SL14222	REGISTER	1
56	SL23050	FAIRLEAD	1
57	SL04075	SCREW	1

		<b>CODE:</b>	pl1070 ab SN from 00E000		
<b>DESCRIPTION:</b>	SQUEEGEE 95	SQUEEGEE 95	SQUEEGEE 95	SQUEEGEE 95	SQUEEGEE 95

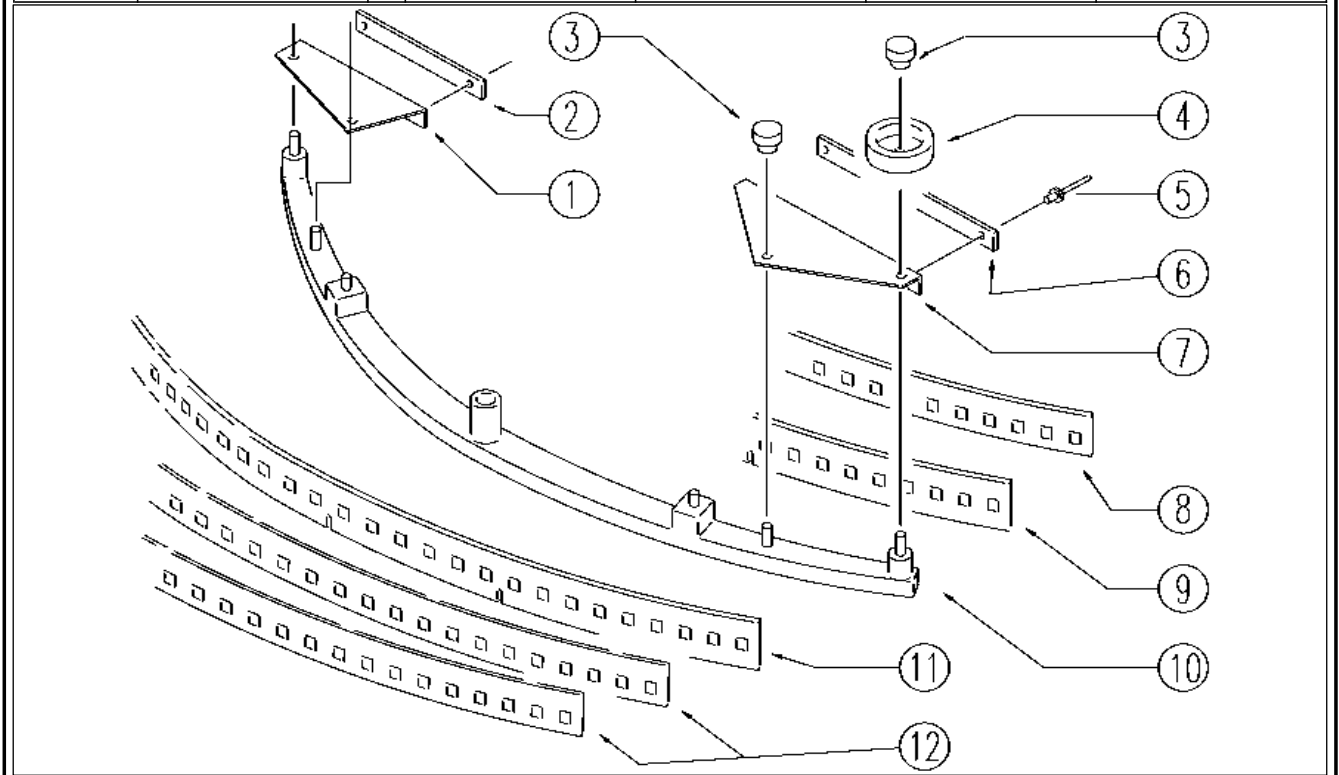

REF.	CODE	DESCRIPTION	QT
1	E89531	Bumper AS36	1
2	E89533	Strip Band AS36	1
3	E86850	Knob	2
4	E86841	Squeegee Wheel Guide	2
5	E89296	Rivet	4
6	E89534	Strip Band AS36	1
7	E89532	Bumper AS36	1
8	E86345	Black Blade Retainer	1
9	E86343	Front Squeegee Blade	1
10	E86985	Squeegee Body	1
11	E86929	Rear squeegee blade	1
12	E86345	Black Blade Retainer	2

DESCRIPTION:	HEAD FASTENER	CODE:	KOPFHALTER	BUTEE TETE	RETÉN CABEZA	FERMA TESTATA
--------------	---------------	-------	------------	------------	--------------	---------------

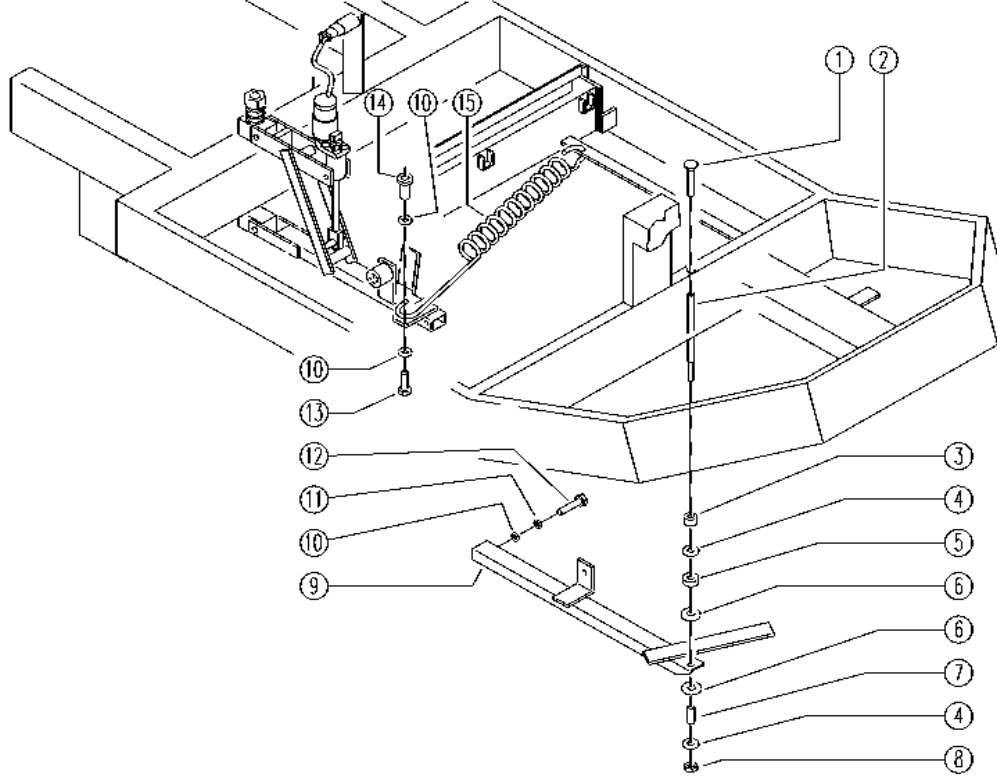

REF.	CODE	DESCRIPTION	QT
1	E86976	Screw M6-12	1
2	E86933	Pivot Pin	1
3	SL07340	SPACER	1
4	E86979	Washer D 8-24	2
5	E86975	Rubber Gasket	1
6	E86980	Washer D13-24-2.5	2
7	E86981	Spacer	1
8	E86853	Nyloc Hex Nut, M8 Zinc	1
9	SL09517	LEVER	1
10	E86707	Cham Washer D10	4
11	E86700	Cham Washer D6	2
12	E89486	Screw	2
13	E86705	Screw TE M 6-30	1
14	SL07054	BUSHING/BUSH	1
15	E86699	Head Spring	1

		<b>CODE:</b>		
<b>DESCRIPTION:</b>	<b>TANK</b>	<b>TANK</b>	<b>RESERVOIR</b>	<b>TANQUE</b>
				<b>SERBATOIO</b>

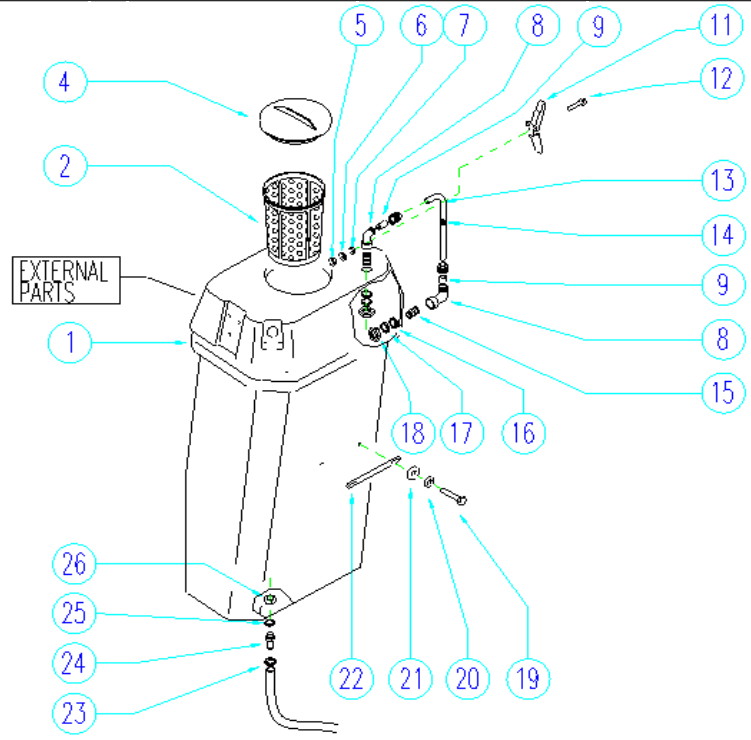

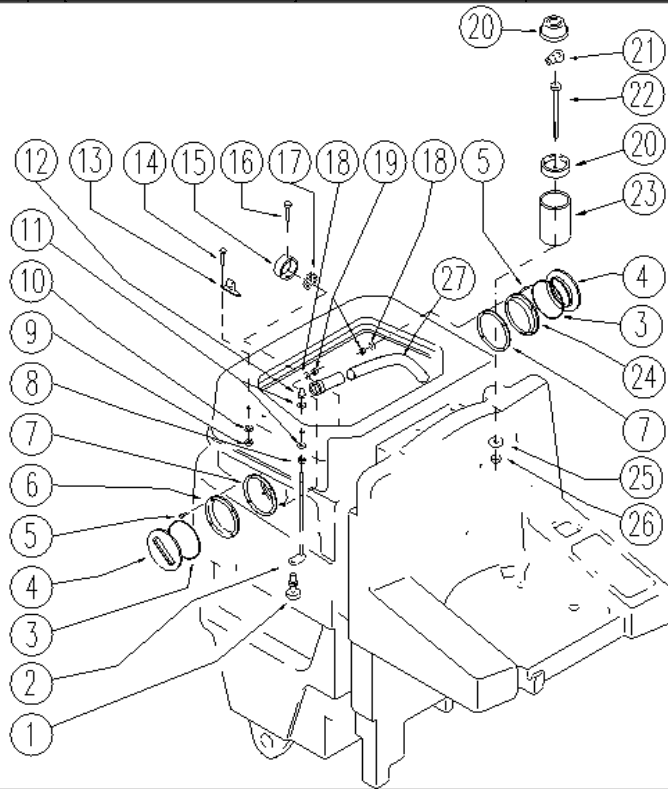

REF.	CODE	DESCRIPTION	QT
1	SL03417	GASKET	1
2	GR18352	FILTER	1
4	E86518	Cover	1
5	E86749	Nut M5 UNI 5588	6
6	E86448	AS20 Washer	6
7	E87876	Gasket	6
8	SL18392	UNION / CONNECTOR	2
9	SL19323	HOSE	2
11	E86765	Lid Clamp WS36T	2
12	SL04244	SCREW	6
13	SL19324	HOSE	1
14	SL14347	SPHERE / BALL	1
15	SL18391	NIPPLE	2
16	E86942	Rubber Gasket	2
17	SL06089	WASHER	2
18	SL18093	NUT	2
19	SL04055	SCREW	2
20	E86448	AS20 Washer	2
21	SL07394	BUSHING / BUSH	2
22	SL17529	HANDLE	1
23	E86546	clamp WS36	1
24	SL07518	UNION / CONNECTOR	1
25	E86942	Rubber Gasket	1
26	SL18093	NUT	6

			<b>CODE:</b>	<b>pl1217 ac SN from 00F500</b>	
<b>DESCRIPTION:</b>	<b>TANK:ACCESSORIES</b>	<b>TANK:ZUBEHÖR</b>	<b>RESERVOIR:ACCESSOIRE</b>	<b>TANQUE:ACCESORIO</b>	<b>SERBATOIO:ACCESSORI</b>

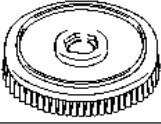
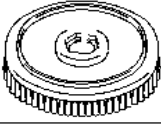

REF.	CODE	DESCRIPTION	QT
1	E86835	Floating Switch	1
2	SL09881	ROD	1
3	E86393	gasket	2
4	E86394	cap	2
5	SL04380	SCREW	8
6	E86395	nut	1
7	E86396	gasket	2
8	E86749	Nut M5 UNI 5588	1
9	E86552	nut	4
10	E86707	Cham Washer D10	4
11	E86448	AS20 Washer	2
12	SL05057	NUT	1
13	SL09880	BRACKET	2
14	E86871	Screw	4
15	SL07449	SUPPORT	1
16	SL04094	SCREW	1
17	SL18252	FILTER	1
18	E89118	Washer	8
19	E89248	Nut	8
20	SL23464	FLASH-LIGHT	1
21	E86919	AS30/36 Bulb	1
22	E86794	Screw	1
23	SL07517	SPACER	1
24	SL14325	NUT	1
25	E86719	AS20 Washer	1
26	E86875	Self-Locking Nut	1
27	E86419	Streaked Hose	1

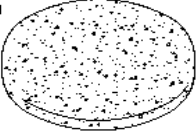
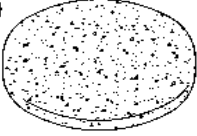
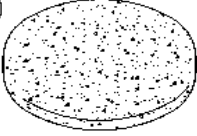
		CODE:		p1237 aa SN from 98A100
DESCRIPTION:	BRUSHES ø450	BURSTEN ø450	BROSSES ø450	CEPILLOS ø450 SPAZZOLE ø450
	<p>POLYPROPYLENE - NYLON - NYLON NYLON - NYLON</p> <p>1</p> 	<p>POLYSHING - POLIERBURSTERN SORGHO - FIBRA - BASSINA</p> <p>2</p> 	<p>TYNEX - TYNEX - TYNEX TYNEX - TYNEX</p> <p>3</p> 	
	<p>4</p> 			
	<p>BLACK - SCHWARZ - NOIR PAD - NERO</p> <p>5</p> 	<p>GREEN - GRUEN- VERT VERDE - VERDE</p> <p>6</p> 	<p>YELLOW - GELB - JEUNE AMARILLO - GIALLO</p> <p>7</p> 	

REF.	CODE	DESCRIPTION	QT
1	AL04705	POLYPROPYLENE BRUSH	
2	AL04707	POLYSHING BRUSH	
3	AL04706	TYNEX BRUSHES	
4	AL04701	PAD DRIVER	
5	AL02219	STRIPPING PAD(BLACK)	
6	AL02220	STRIPPING PAD(GREEN)	
7	AL02221	STRIPPING PAD(YELLOW)	

CODE:

pl1277 ae SN from 00E200

DESCRIPTION:

EXTERNAL PARTS

EXTERNE TEILE

EXTERNES PARTIES

EXTERNAS PARTES

PARTI ESTERNE

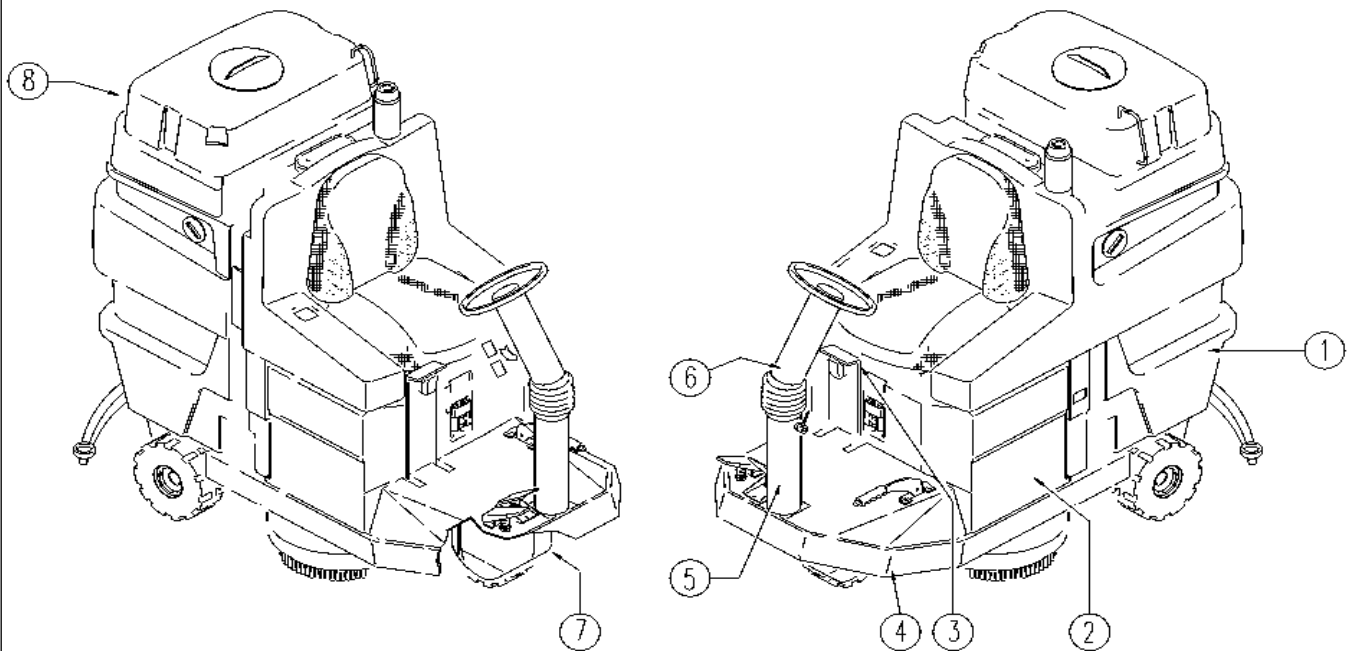

REF.	CODE	DESCRIPTION	QT
1	SL17531VE	GREEN TANK	1
1	SL17531AS	GREY TANK	1
1	SL17531RO	RED TANK	1
2	SL17342NE	BLACK BOX	1
2	SL17342BC	RED BOX	1
3	SL09814F	HANDLE	1
4	SL39006	FRAME	1
5	SL09696F	STEERING COLUMN	1
6	SL09697F	STEERING COLUMN	1
7	SL17337NE	CASE	1
7	SL17337BC	RED CASE	1
8	SL17516NE-2	BLACK TANK	1

		<b>CODE:</b>		<b>pl1381 ab SN from 00A101</b>	
<b>DESCRIPTION:</b>	<b>HEAD 95 FLAP and BOX</b>	<b>KOPF</b>	<b>TETE</b>	<b>CABEZA</b>	<b>TEST. 95: FLAP E CASSETTO</b>

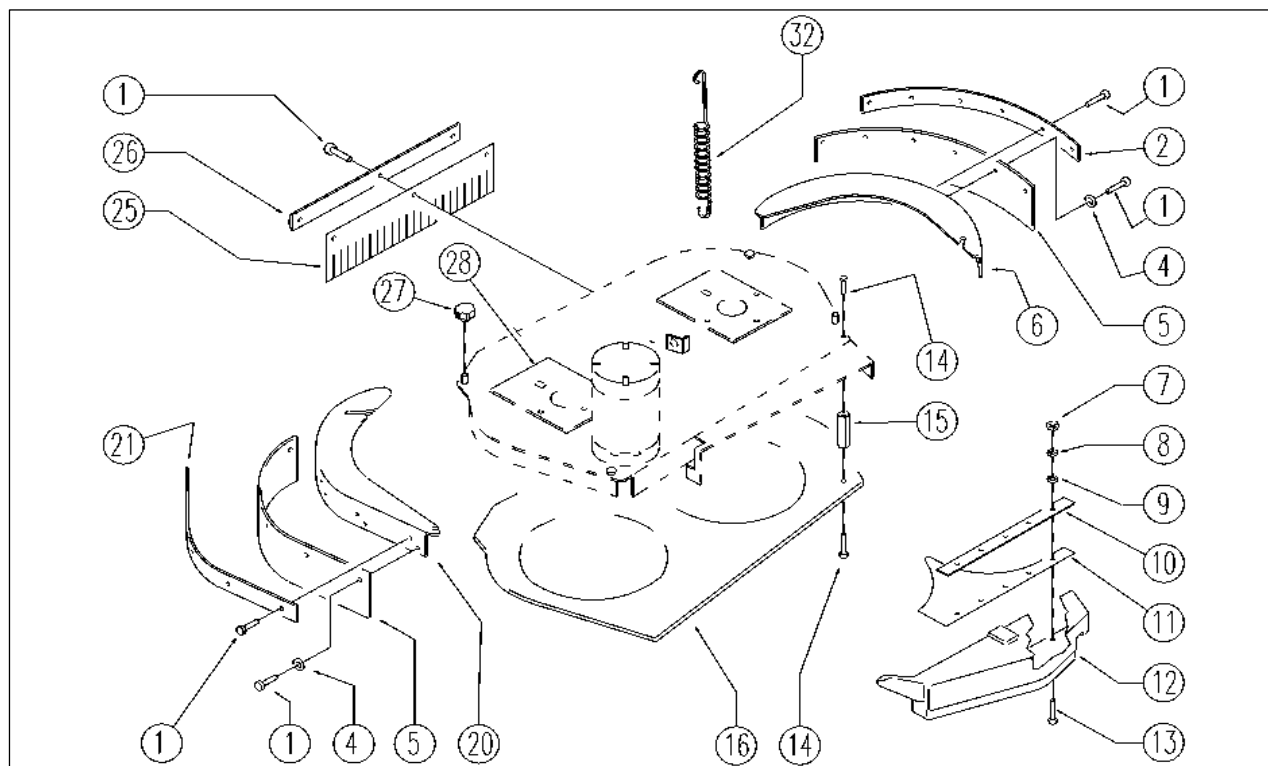

REF.	CODE	DESCRIPTION	QT
1	E89469	M4 - 15 Screw	23
2	E89295	Flap press WS36T	1
4	E89118	Washer	10
5	E87781	Flap, Splash Guard Side W	2
6	SL09883	COVER	1
7	E86735	Nut	5
8	E86769	Washer	5
9	E86768	Washer	5
10	SL21133	LAMINATION	1
11	E86821	Collecting Box	1
12	E86898	Dust Collector	1
13	SL04364	SCREW	5
14	E86970	Screw M4, 2-13	14
15	SL14205	SPACER	7
16	SL03425	GUARD	1
20	SL09882	COVER	1
21	E89294	Flap press WS36T	1
25	E87782	Flap, Splash Guard	1
26	SL03426	FLAP PRESS	1
27	MP06100	HANDLE	2
28	SL03291	GASKET	2
32	E86699	Head Spring	1



			wd27126-1 aa SN from 98F217	
DESCRIPTION:				
REF.	DESCRIPTION	CODE		QT
- <	DIODE			
A	MOTOR			
AA	WARNING HORN			
ALT	ACTUATOR			
AN#	CONNECTOR			
AST	ACTUATOR			
C	CAPACITOR			
CF#	CONNECTOR			
CM#	CONNECTOR			
CPDS	GEARCASE / BOARD			
CT	GEARCASE / BOARD			
F#	FUSE			
FCH	PUSHLOCK			
H	TIME COUNTER (OPTIONAL)			
I AC	SWITCH			
I A	SWITCH			
IB	SWITCH			
L	FLASHING LIGHT			
LS	PROBE			
MCB	MICROSWITCH			
MFM	MICROSWITCH			
MS	MOTOR			
MT	MOTOR			
PP	POTENTIOMETER			
PSD	PUMP			
PT	POTENTIOMETER			
R	RESISTANCE			
R1	RESISTANCE			
R2	RESISTANCE			
R3	RESISTANCE			
R4	RESISTANCE			
R7	TRIMMER			
SB	PILOT LIGHT			
SHUNT	SHUNT			
SPU	SENSOR			
T	SENSOR			
TS	TELESWITCH			
CPA	GEARCASE / BOARD			
CA	GEARCASE / BOARD			
D	DIODE			
IT	PUSH-BUTTON			
IUL	PUSH-BUTTON			
PAA	PUSH-BUTTON			
PMI	PUSH-BUTTON			
MB	MICROSWITCH			
MA	MICROSWITCH			
MSP	MICROSWITCH			
TM	THERMOSTAT			
SSB	SENSOR			