

Parts and Service Manuals From:



On Line Materials for the Jan San Industry.

Since 1922

**Michigan Company Inc.
2011 N. High St.
Lansing, Mi 48906
(517) 484-9312**

[Http://www.Michco.Com](http://www.Michco.Com)

Email:Shop@Michco.com

Order parts on line or by Phone

Visa, MasterCard, Amex

Shipping to US addresses only.

Materials contained in this manual Copyright respective manufacturer, PDF version made exclusively by Michco for our customer's use only. Any other use of PDF version violates our PDF copyright.



OPERATOR'S MANUAL

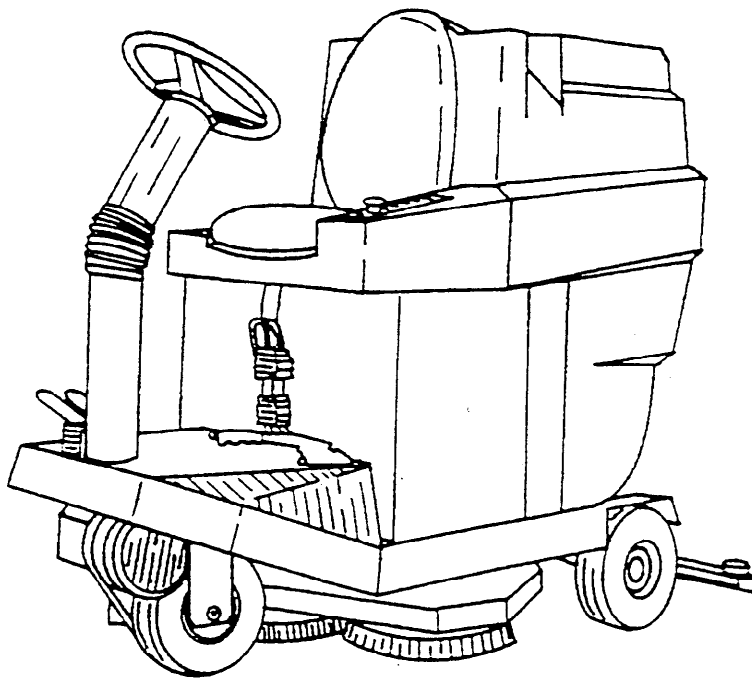

AS 30R RIDER AUTOMATIC ***AS 36R RIDER AUTOMATIC***

AUTOMATIC-SWEEPING-SCRUBBER

ENGLISH

1	GENERAL INFORMATION.....	page 4
1.1.	PURPOSE OF THE MANUAL	page 4
1.2.	IDENTIFICATION OF THE MACHINE MANUFACTURER	page 5
1.3.	DOCUMENTATION ENCLOSED WITH THE MACHINE	page 5
2	TECHNICAL INFORMATION.....	page 6
2.1.	GENERAL DESCRIPTION	page 6
2.2.	PRINCIPAL PARTS AND WORK CYCLES	page 6
2.3.	TECHNICAL SPECIFICATIONS.....	page 8
2.4.	DIMENSION.....	page 10
2.5.	DETERGENTS - ADVICE FOR USE	page 10
2.6.	SAFETY DEVICES	page 11
2.7.	DANGER ZONES	page 12
2.8.	OPTIONAL UNITS	page 12
2.9.	ACCESSORIES	page 13
3	SAFETY INFORMATION	page 14
3.1.	SAFETY STANDARDS	page 14
4	HANDLING AND INSTALLATION	page 16
4.1.	PACKING	page 16
4.2.	LIFTING AND TRANSPORT.....	page 16
4.3.	UNPACKING AND CLEANING.....	page 16
4.4.	SQUEEGEE - INSTALLATION	page 18
4.5.	FEEDING BATTERIES	page 18
4.5.1	Batteries - Use	page 19
4.5.2	Batteries - Installation.....	page 19
4.5.3	Connecting the batteries	page 20
4.6.	RECHARGING THE BATTERIES.....	page 20
4.6.1	Choosing the battery-charger.....	page 20
4.6.2	Batteries - Recharging procedure	page 21
4.7.	LIFTING AND HANDLING OF THE MACHINE	page 23
5	SETTING UP.....	page 24

5.1.	SQUEEGEE - ADJUSTMENT.....	page 24
5.2.	STEERING COLUMN - REGULATION.....	page 24
5.3.	DRAINING OFF DIRTY WATER.....	page 25
5.4.	DRAINING AND FILLING WITH WATER AND DETERGENT SOLUTION.....	page 26
5.5.	DIRT COLLECTING BOX - REMOVING AND FITTING.....	page 27
5.6.	BRUSHES - INSTALLATION.....	page 28
5.7.	PREPARING THE MACHINE FOR WORK.....	page 29

6	USE.....	page 30
6.1.	DESCRIPTION OF THE CONTROLS.....	page 30
6.2.	SQUEEGEE - USE.....	page 32
6.3.	PARKING BRAKE - USE.....	page 32
6.4.	DRIVING THE MACHINE.....	page 33
6.5.	PROCEDURES FOR USING THE MACHINE.....	page 33
6.6.	EXTRACTABLE HEAD - USE.....	page 34
6.7.	RECYCLING SACK ACCESSORY - USE.....	page 35
6.8.	COMBI ACCESSORY - USE.....	page 36
6.9.	SWEEPING HEAD ACCESSORY - USE.....	page 37
6.10.	HOURLY METER ACCESSORY - USE.....	page 38
6.11.	ADVICE ON OPTIMUM USE OF THE MACHINE.....	page 38

7	MACHINE MAINTENANCE.....	page 39
7.1.	MAINTENANCE - GENERAL RULES.....	page 39
7.2.	ROUTINE MAINTENANCE.....	page 39
7.2.1	General cleaning.....	page 39
7.2.2	Suction filter - Cleaning.....	page 40
7.2.3	Cleaning liquid input hole - Cleaning.....	page 40
7.2.4	Squeegee blades - Replacement.....	page 40
7.2.5	FLAPS - Replacement.....	page 41
7.2.6	Dirt collecting scraper - Replacement.....	page 42
7.2.7	Diaphragm sack - Replacement.....	page 42
7.2.8	Recycle accessory - Cleaning and replacement.....	page 43
7.2.9	Float - Cleaning.....	page 43
7.2.10	Pump impeller - Cleaning.....	page 44
7.2.11	Fuses - Replacement.....	page 44
7.3.	PERIODIC MAINTENANCE.....	page 45
7.3.1	Daily maintenance.....	page 45
7.3.2	Weekly maintenance.....	page 45

7.3.3 Six-monthly maintenance page 46
7.3.4 Preparing for long periods of inactivity page 46

8 TROUBLESHOOTING page 47
8.1. HOW TO OVERCOME ANY PROBLEMS page 47

All rights reserved.
All duplication, even partial, of the contents of this manual is forbidden, unless authorized in writing by the Manufacturer.

Even if the machine in your possession is quite different from the illustrations in this document, their safety and the information herein are guaranteed.

1.2. IDENTIFICATION OF THE MACHINE MANUFACTURER (fig. 1)

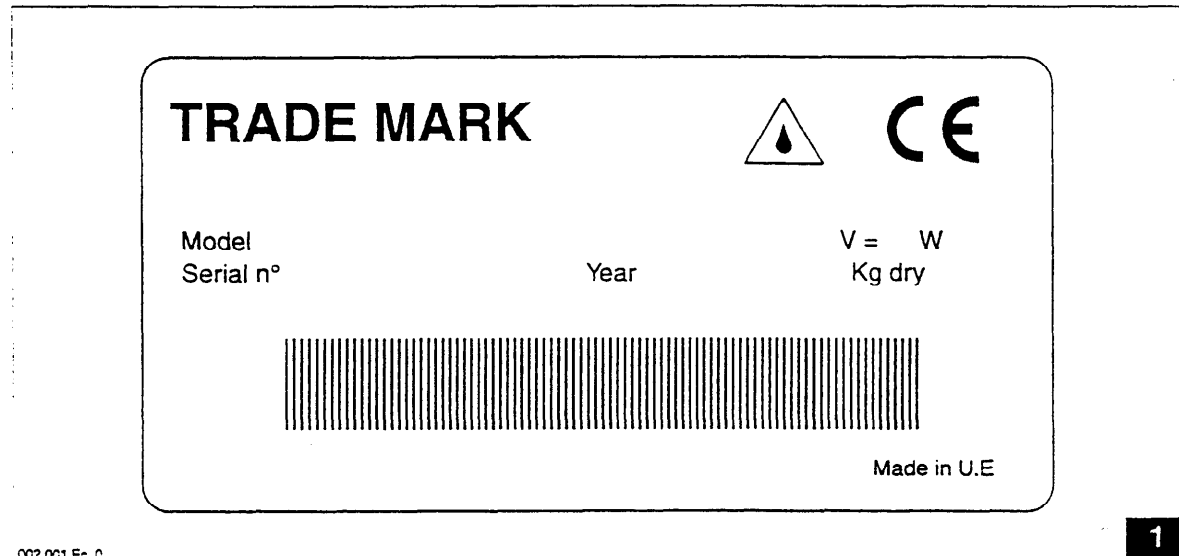

The data plate gives:

- The product code.
- The model.
- The voltage.
- Total rated power.
- Serial number.
- Year of manufacture.
- Dry weight.
- Maximum load weight.
- Maximum gradient.
- Bar code with serial number.
- Manufacturer identification.

1.3. DOCUMENTATION ENCLOSED WITH THE MACHINE

- Operator's manual.
- Guarantee certificate.
- Adhesive cards for ordering spare parts.
- Inspection sheet.
- CE conformity certificate.

2

TECHNICAL INFORMATION

2.1. GENERAL DESCRIPTION

The machine is used in civil and industrial areas for sweeping, washing and drying flat, horizontal, smooth and moderately rough floors, with even surfaces free from obstacles. When used with the Combi accessory, areas inaccessible to the machine may be washed and dried.

The power supply with storage batteries and the high capacity of the batteries that may be used allow **maximum freedom of movement** and independent work time **to suit all working conditions**.

A large tank, various high-power scrubbing and sweeping heads, a powerful drive motor allow maximum efficiency and effective washing to be combined with extreme simplicity of use.

With the electronically-controlled drive and forward and reverse gears, any path may be easily followed on the floor to be cleaned.

2.2. PRINCIPAL PARTS AND WORK CYCLES (fig. 1)

- A - Group of batteries.
Supplies energy for feeding the machine.
- B - Tank unit.
Contains the mixture of clean water and detergent and collects the dirty water lifted from the floor.
- C - Controls.
- D - Chassis.
- E - Scrubbing and sweeping head unit.
Distributes the detergent solution on the floor, removing the dirt and collecting refuse.
- F - Squeegee suction unit.
Collects and lifts the water, drying the floor.
- G - Drive unit.
This is composed of an electronically controlled geared motor which allows the machine to move backwards and forwards.
- H - Control drive unit.
- I - Sweeper head units.

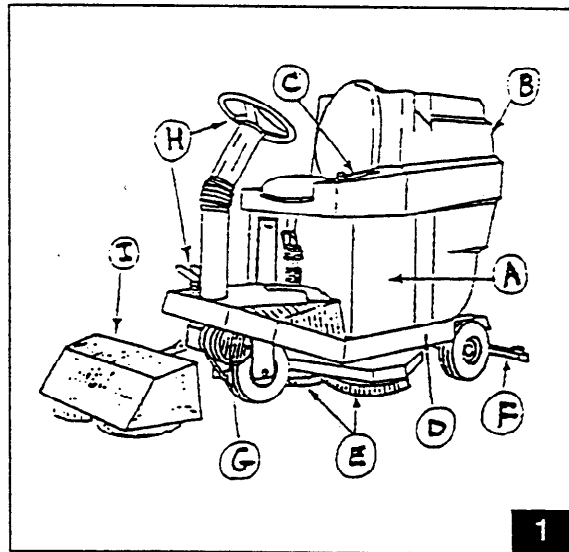

Operating cycle (fig. 2)

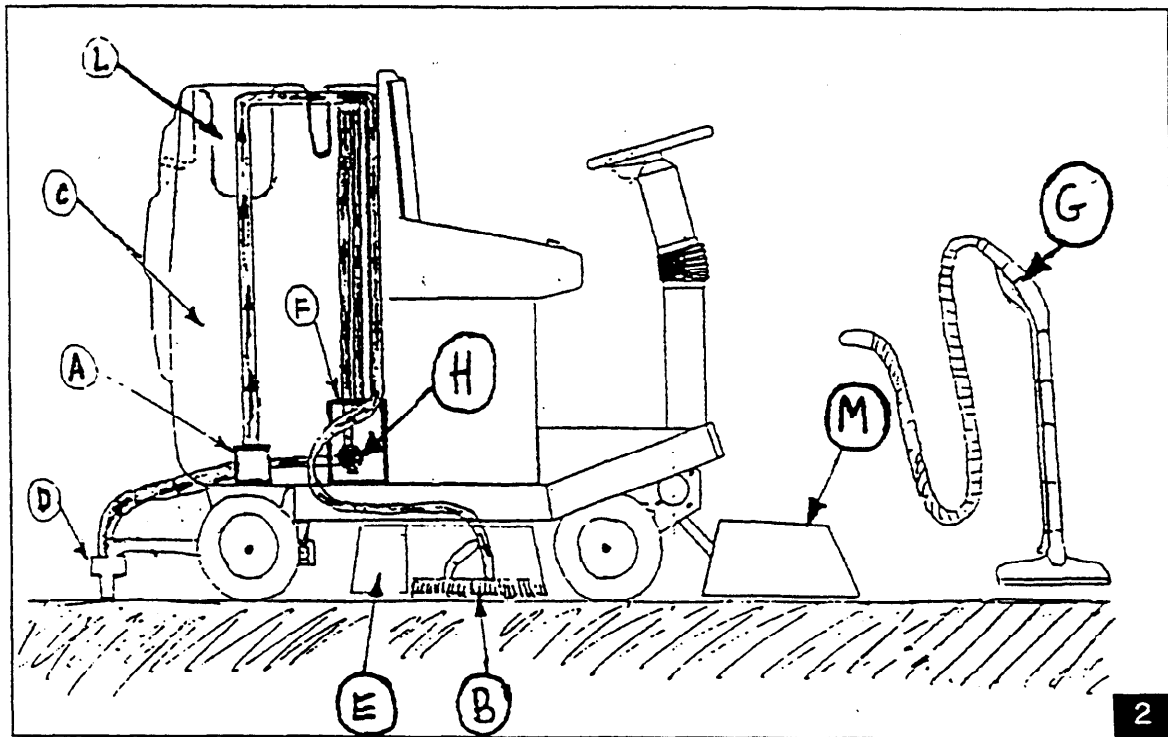

By means of the pump **A**, the machine sends a suitably dosed solution of water and detergent to the brushes **B**, from the tank **C**.

The rotation of the brushes distributes the solution, removes the dirt and lifts the refuse, depositing it in the collection box **E**.

After scrubbing, the floor is dried automatically by the squeegee **D**, using a suction system that sends the dirty water to the tank **C**.

A centrifugal compressor **F** (henceforward to be referred to as the suction device) sucks up the air from the tank **C**, creating a vacuum. The squeegee **D** is connected to the tank; it scrapes the dirty water up off the floor and collects it, allowing it to be sucked up into the tank.

The ability to sweep, the possibility of fitting brushes with different material fibres (or even abrasive discs on models with disc brushes), together with an accurate choice of detergent, allow the machine to adapt to the most varied combinations of floor and dirt.

Accessory Combi **G** (Optional), to insert in the corresponding socket **H** (off-the-shelf), allows the machine to wash in inaccessible positions such as corners, stairs, cluttered floor areas.

The accessory recycling sack **L** (Optional) allows to extend work autonomy and to reduce the consumption of detergent recovering, with an opportune filtering, the water intake from the floor and sending it again to the brushes.

The accessory sweeper head **M** (Optional) allows to remove coarse dirt.

2.3. TECHNICAL SPECIFICATIONS

MACHINE		AS 30R	AS 36R
Head lifting actuator rated load	daN (kg)	120	120
Adjustable vertical force on the head	daN (kg)	21÷85	23÷85
Suction motor rated power	W/HP	650/0.87	650/0.87
Max. suction vacuum	mm H ₂ O	1600	1600
Drive motor rated power	W/HP	750/1	750/1
Advance rated speed	km/h	6,5	6,5
Drive control		electronic with continuous speed variation (forward and reverse gear)	
Detergent solution pump rated power	W/HP	25/0.033	25/0.033
Water pump max. flow rate	l/min	21	21
Diaphragm tank capacity	l	300	300
Max. temperature water and detergent solution	°C	50	50
Drive wheels diameter	mm	308	308
Turning radius	mm	1450	1450
Rear brakes		drum brake	drum brake
Sound pressure level	dB (a)	68	68
Dry weight without batteries (body only)	kg	320	320
Usable batteries minimum capacity	Ah (5)	220	220
	Ah (20)	300	300
Usable batteries maximum capacity	Ah (5)	368	368
	Ah (20)	535	535
Installable batteries maximum weight	kg	410	410
6V battery max. dimensions (LxWxD)	mm	249x198x498	249x198x498
Clean track maximum width	mm	750	900
Swinging squeegee width		1080	1280
Hourly performance	m ² /h	4875	5850
Working environment temperature (min-max)	°C	4÷35	4÷35
Number of brushes		2	2
Brush rated diameter	mm/inch	380/18"	450/18"
Diameter of abrasive discs	mm/inch	380/15"	450/18"
Brush rotation speed	g/min	225	225
Number of washing head motors		1	1
Washing head motor rated power	W/HP	1500/2	1500/2
Accessory for side movement of head		available	available
Dirt collection basket capacity	l	5	5
Head weight	kg	40	50
Squeegee weight	kg	6,6	7,6
Length, width, height	mm	1800x810x1500	1800x970x1500

MACHINE		AS 30R	AS 36R
Weight with packing and pallet	kg	820	820
Dimensions of packing with pallet (LxWxH)	mm	1925x1105x1760	1925x1105x1760

ACCESSORY		HEAD SIDE MOVEMENT
Rated load of head side movement actuator	daN (kg)	90
Head side movement	mm	330

ACCESSORY		BATTERY ROOM
Weight	kg	65
Dimensions (LxWxH)	mm	892x740x376
Weight with packing	kg	80
Dimensions of packing (LxWxH)	mm	1470x810x1080

ACCESSORY		SWEEPING HEAD
Weight	kg	27
Dimensions (LxWxH)	mm	850x780x350
Weight with packing	kg	32
Dimensions of packing (LxWxH)	mm	1000x720x410

2.4. DIMENSION (fig. 3)

Head	B
30R	810
36R	970

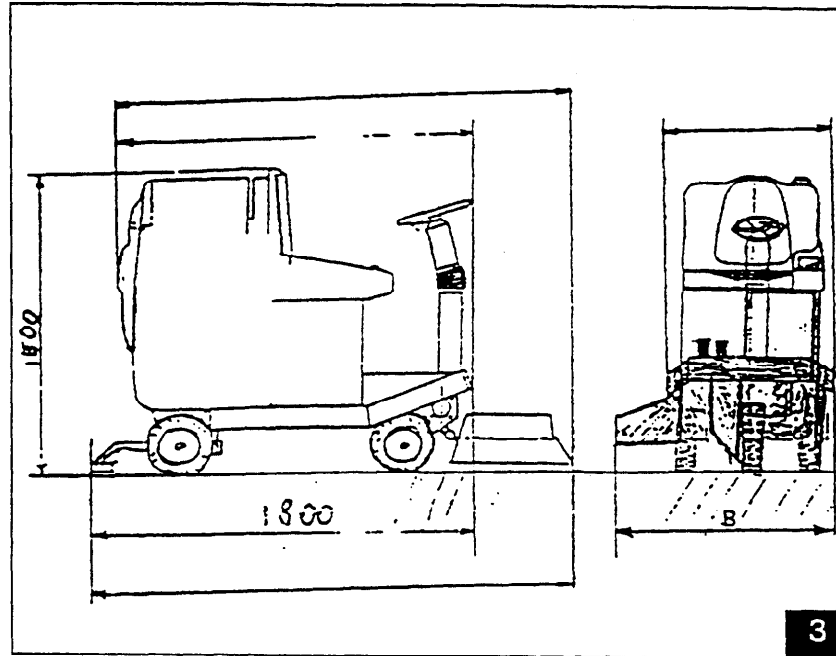

2.5. DETERGENTS - ADVICE FOR USE

The machine has been designed for use with specific detergents for floor sweeping and scrubbing machines.

Use only non foam-producing and biodegradable detergents, suitable for the type of floor and the dirt to be removed.

Follow the safety standards related to detergent use indicated in paragraph 3.1.

**WARNING**

Always dilute the detergents according to the manufacturer's instructions. Do not use sodium hypochloride (bleach) or other oxidizing agents, especially in high concentrations, and do not use solvents or hydrocarbons. The water and the detergent must be at temperatures no higher than the maximum value indicated in the technical data and they must be free from sand and/or other impurities.

**WARNING**

If you use particularly powerful detergent, pour first the water into the tank and thereafter the detergent in order to avoid damages in the pump or the diaphragm.

2.6. SAFETY DEVICES (fig. 4)

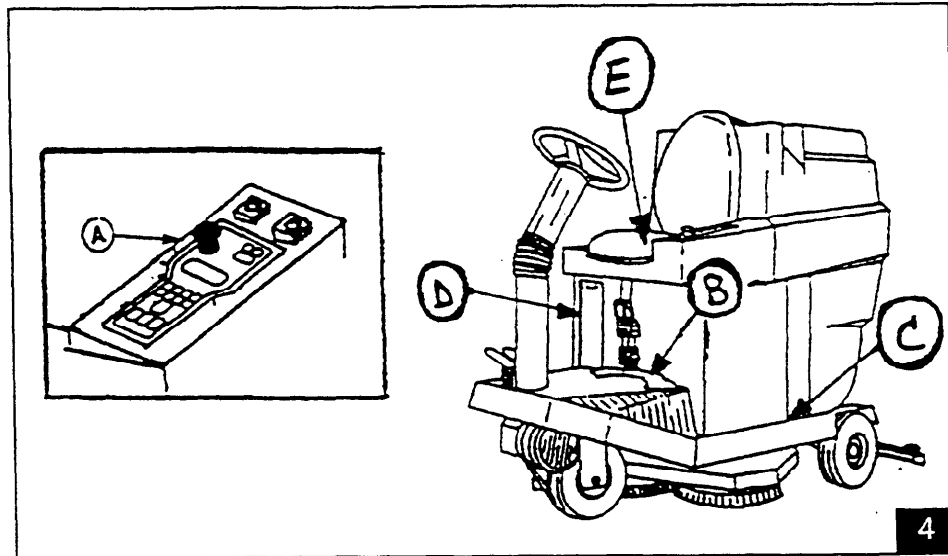

	Device	Activation	Function
A	Emergency button.	Activated when pressed.	Interrupts power supply.
-	Service brake.	Engages automatically when the accelerator is released.	The machine slows down gradually.
B	Hand brake.	Engages when the lever B is raised.	If it is pulled the drive is stopped (interrupted).
C	Battery box block lever.	Hook pulling the battery box to the bottom the seat locked under the operator seat.	If it is not hooked, interrupt the drive.
D	Tank blok lever.	Hook pulling up and insert on the spline located in the tank under the operator seat.	If it is not hooked, interrupt the drive.
E	Weight sensor.	Sense operator presence seated on the driving place.	Interrupt the drive if the operator is not seated and stop the brushes.

2.7. DANGER ZONES (fig. 5)

A - Tank. In presence of certain detergents, danger of irritation for the eyes, skin, mucous membranes, respiratory system, danger of asphyxia.

Danger due to the dirt recovered from the environment (germs and chemical substances).

Danger of crushing between the tank and chassis during the tank lock-up operation.

B - Battery compartment. Danger of short circuits between the battery poles and presence of hydrogen during battery charging. Charge the batteries in a ventilated area, with the hood open.

C - Battery box. Danger of the machine turnover during the box take-out operation.

D - Head side movement actuator. Danger of crushing due to moving parts.

E - Top of the washing head. Danger of crushing between the top of the brush head and the chassis.

F - Dirt collecting basket compartment.

The brushes are accessible when the basket is not in position.

G - Bottom of the washing head.

Danger when lowering the head and brush rotation.

H - Electric components plate. Danger of short circuit.

I - Back wheels upper part. Danger of crushing between the wheel and chassis.

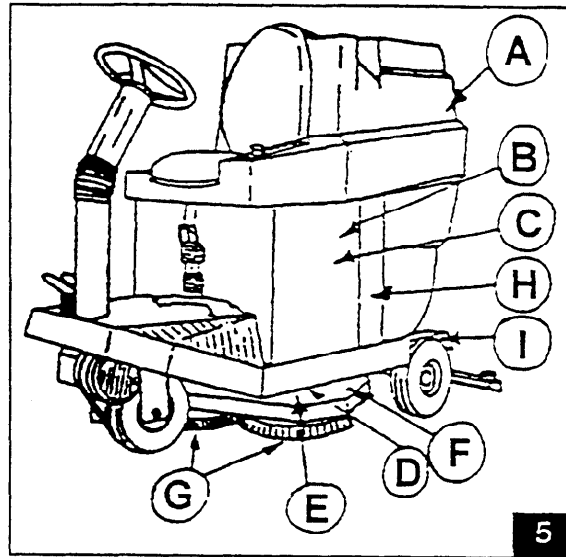

2.8. OPTIONAL UNITS

Recycling unit:

allows prolonged work time and reduction of detergent consumption by recovering the water taken up from the floor, by means of a suitable filtering system, and sending it back to the brushes.

Combi Set:

a quick coupling is fitted on the machine in the factory to allow the use of an accessory for washing and drying where the machine cannot do the job itself (stairs, under-stair area, inaccessible corners, etc).

Sweeping Head:

Placed in front of the anterior wheel allows to remove the coarse dirt.

2.9. ACCESSORIES

- Bristle brushes.
Used for washing delicate floors and for polishing.
- Polipropilene brushes.
Used for normal floor washing.
- Tynex brushes.
Used for accumulated stubborn dirt on resistant floors.
- Drive discs.
Allow the use of the discs described below:
 - Yellow discs.
Used for washing and polishing marble and similar surfaces.
 - Green discs.
Used for washing resistant floors.
 - Black discs.
Used for thorough washing of resistant floors, with stubborn dirt.
- Combi Set.
- Carpet head for Combi Set.
- Strip head for Combi Set.
- Sucker head for Combi Set.
- Recycling filter sack.

3

SAFETY INFORMATION

3.1. SAFETY STANDARDS



Read the instructions manual carefully before proceeding with the start-up operations, use, maintenance, routine maintenance or any other jobs on the machine.



WARNING

Scrupulously respect all the advice given in the manual (especially those concerning danger and special attention), and the safety plates applied directly on the machine. The Manufacturer declines all responsibility for damage to persons or things resulting from failure to respect the safety indications.

The machine may only be used by trained personnel that has demonstrated its own capacity and that has been explicitly assigned to the use of it.

Use of the machine is forbidden for minors.

Do not use this machine for purposes other than those for which it is intended. Consider the type of building that you are working in (e.g. pharmaceutical, chemical industries, etc.) and scrupulously respect the standards and safety conditions in force there.

Do not use this machine in places inadequately illuminated, explosive environment, public roads, in the presence of noxious dirt and in insanitary environments.

On high speed danger of turnover in a curve. With empty tank the danger increases.

Do not inhale flammable or explosive liquids (ex. gasoline, combustible oil, etc.), flammable gas, dry dust, acids and solvents (ex. thinner, acetone, etc.) even if diluted.

Do not inhale steam from burning or boiling objects.

Do not use the machine on slopes with a gradient of more than 2%. When transporting the machine or ramps or higher slopes, use the maximum care to avoid overturning and uncontrolled acceleration. Overcome ramps and steps always by lifting brushes head and squeegee. Never park the machine on a slope.

Do not leave the machine unguarded when the engine is on. Leave the machine only after you have switched off the engine, insured the machine against accidental movements, pulled the hand break and pulled out the ignition key.

Do not use the machine to transport person/things or to tow things.

Never lean weights on the machine for any reason.

Never block the ventilation and heat dispersion openings.

Do not remove, modify or avoid the safety devices.

Many unpleasant experiences have shown that various parts of people's clothing may cause severe accidents: before starting work, remove any jewelry, watches, ties or other accessories.

Always use the individual protections for operator safety recommended by the Manufacturer: protective overalls or apron, no-slip waterproof shoes, rubber gloves, protective eye-glasses and a mask to protect the respiratory organs.

Do not put your hands close to the moving parts.

Do not use detergents different from the recommended ones and follow their related safety instructions.

We recommend you to keep detergents out of reach of children and in case of contact with the eyes rinse immediately with water and in case of consumption contact immediately a doctor.

It is indispensable to observe the battery manufacturer's instructions and observe the directions of the legislation.

Always keep the batteries clean and dry in order to avoid superficial dispersion of currents. Protect the batteries from impurity, for example metal dust. Do not lean tools against the batteries, danger of short circuit and explosion.

Be attentive when using battery acid. Observe the related safety instructions.

In the presence of particularly high magnetic fields, consider their possible effect on the control electronics.

Do not wash the machine with jet of water.

In the event of breakdown and/or bad operation of the machine, switch it off immediately (disconnecting it from the power mains or from the batteries) and do not tamper with it.

Contact one of the Manufacturer's technical service centres.

All operations on the electrical system and all maintenance and repair jobs not explicitly described in this manual must be performed by specialized technical personnel, experts in the sector.

Only accessories and spare parts sold by the manufacturer are allowed since only these can assure that the machine works safely and without inconvenience.

Do not use parts taken from other machine.

This machine has been projected and constructed for a service length of ten years from the date of manufacture stamped on the data plate. At the end of this period the machine has to be destroyed or go through a complete revision by the manufacturer.

If it is decided not use the machine any longer we recommend you to take out the batteries and leave them for recycling. We also recommend you to empty the tank and to destroy the parts that can be of danger, for example for children that could use a machine that is not in use as a toy.

4

HANDLING AND INSTALLATION

4.1. PACKING (fig. 1)

The machine body is packed and fixed onto a wooden pallet with anchoring brackets; it is covered with a cardboard box closed with strapping.

The head and the squeegees are packed in cardboard boxes without a pallet.

4.2. LIFTING AND TRANSPORT

(fig. 1)

When packed the machine body may be lifted only with a fork lift truck. The heads may also be lifted by hand.

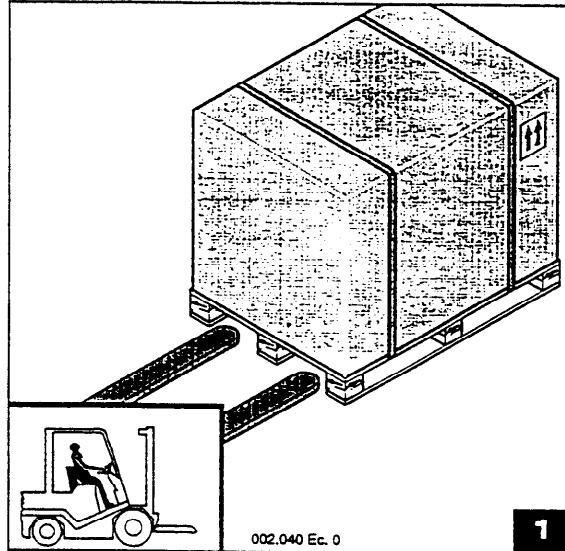

INFORMATION

Handle with care, avoiding jolts, and without overturning.

4.3. UNPACKING AND CLEANING

On delivery, check that the machine is unbroken. If you find it has suffered any damage, report this to the carrier and accept the goods only with your written reserve to present a claim for the refund of damage.

- Cut the strapping **A** (fig. 2).
- Remove the cardboard **B** (fig. 2).
- Remove scaffold **C** (fig. 3).
- Take out the instruction manual, the inspection sheet, the guarantee card, the cards with serial number for ordering spare parts and the envelope inside the battery compartment **D** (fig. 3).
- Check the contents of the envelope:
 - 1 battery cable;
 - 5 bridges with clamps;
 - 1 connector for the battery charger;

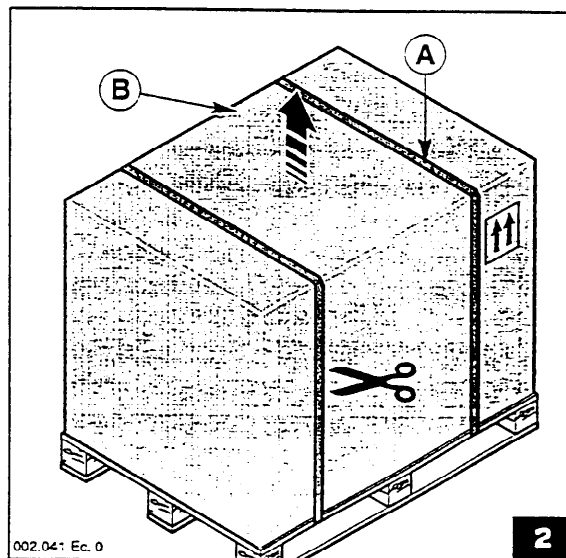

- Two copies of the ignition key.

I INFORMATION

Put one of the two keys in a safe place so that it can be located in case the other one is lost; the other key is to be inserted in the lock on the mushroom switch.

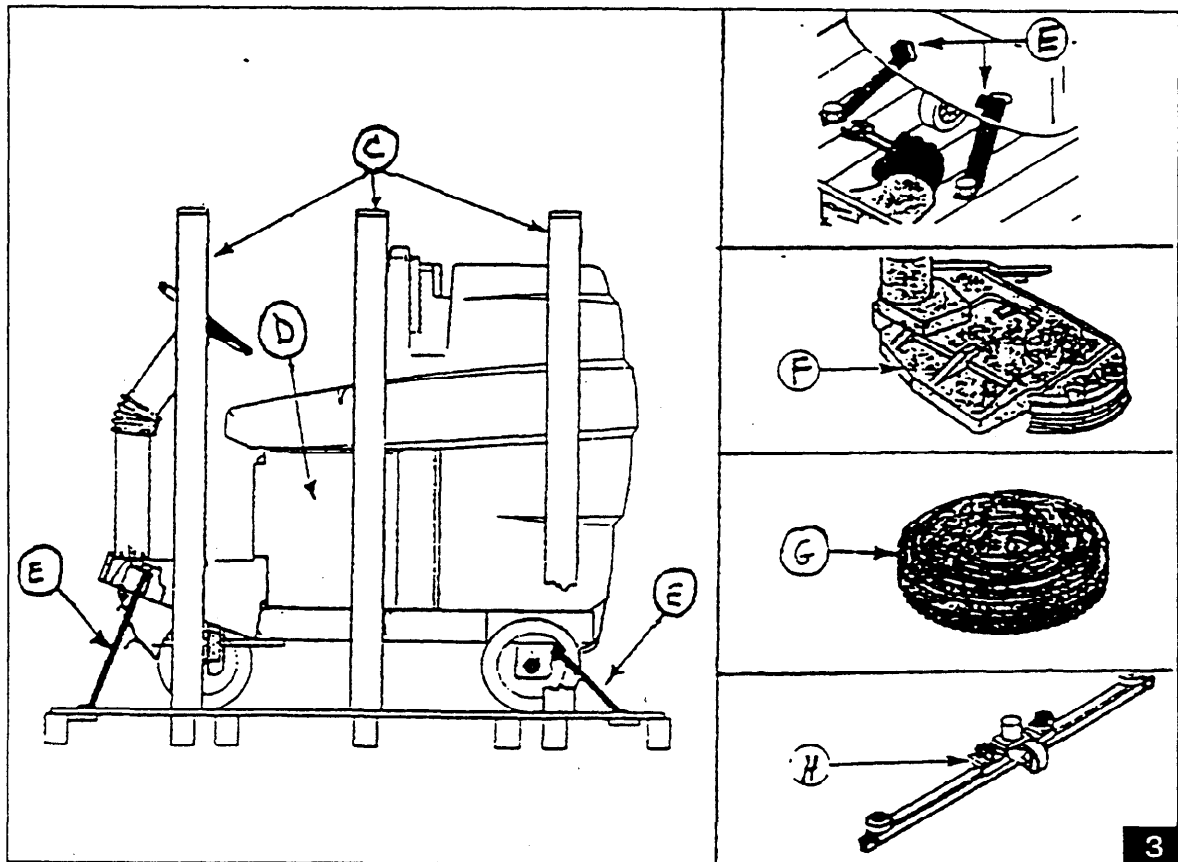

- Unscrew the bolts and remove the brackets **E** (fig. 3).
- Free the head **F**, the brushes **G**, the squeegee **H** from their packing.
- Have the head fitted by an authorized service centre.
- Clean the outside of the machine, following the instructions in paragraph 7.2.1.
- Eliminate the packing material, using containers for separate refuse collection.

4.4. SQUEEGEE - INSTALLATION (fig. 4)

- Lift the squeegee D, operating the pedal D (§ 6.2., fig. 2);
- Slacken the knobs C.
- Insert the squeegee D in the slots in the support A and tighten the knobs C.
- Firmly push down the sleeve of the suction tube E.

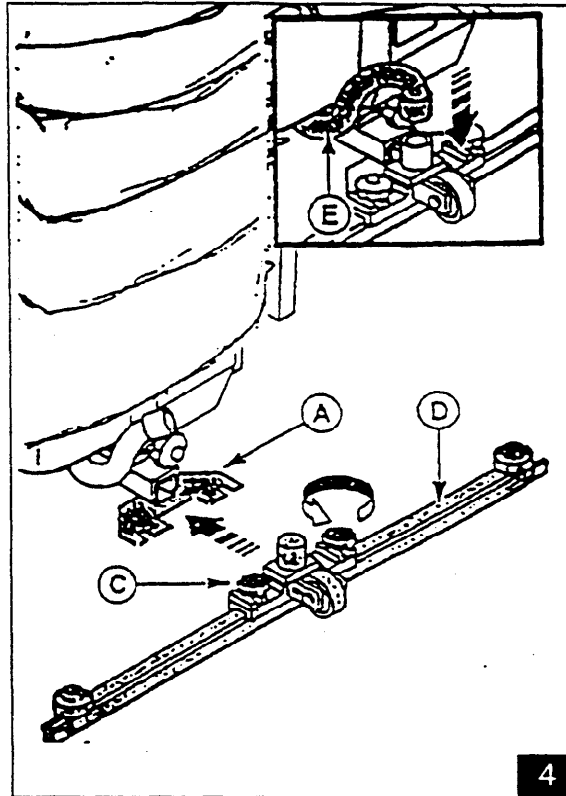

4.5. FEEDING BATTERIES



DANGER

During any kind of battery maintenance follow the related safety instructions for batteries indicated in paragraph 3.1. Besides that:

- wear rubber gloves.
- use an apron or protective overalls.
- use protective eye-glasses.
- wear non-slip waterproof shoes.
- keep away from any naked flames.
- do not short-circuit the battery poles.
- do not cause sparks.
- do not smoke.

Two different types of batteries may be fitted on this machine; their characteristics must correspond with those indicated in (§ 2.3.). They must be kept charged, dry and clean, with their connections tight.

Tubular armored batteries.

The level of the electrolyte in these batteries must be checked periodically.

When necessary, top up with distilled water alone until the plates are covered; do not overfill (max. 5 mm above the plates).

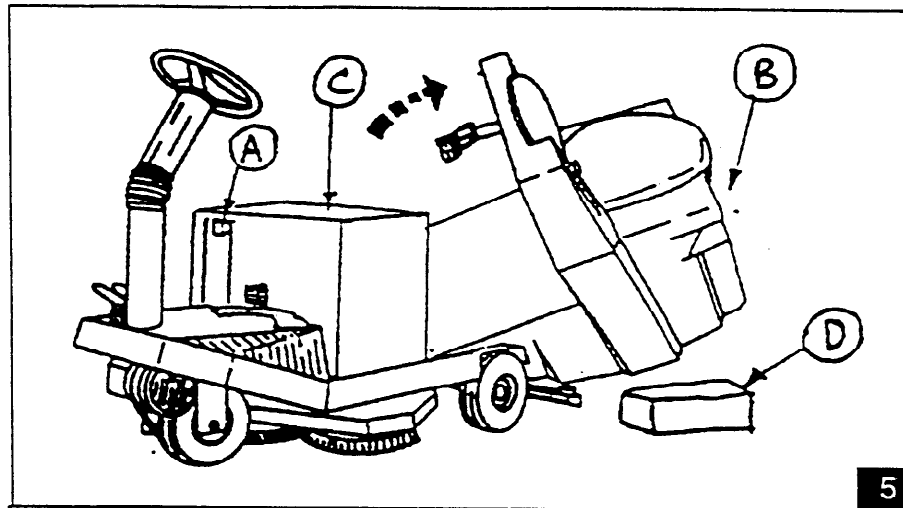

Gel batteries

This kind of batteries do not require maintenance and it is recognized by the machine because of the Anderson connector.

4.5.1 Batteries - Use

When supplied the batteries are normally filled with acid and ready for use. However, before starting the machine it is advisable to recharge them.

Proceed as indicated, see "Batteries - Recharging procedure" (§ 4.6.2.).

4.5.2 Batteries - Installation

- Be sure that the tank is empty and eventually drain it (§ 5.3.).
- Remove the suction tube E (§ 4.4., fig. 4).
- Remove the squeegee D (§ 4.4., fig. 4).
- Press the emergency mushroom A (§ 6.1., fig. 1).
- Disconnect the connector A (fig. 7) from B (fig. 7).
- Release the tank block lever A (fig. 5).
- Lift the tank B (fig. 5), lay it on the block D (fig. 5) of dimensions 300x300x150mm. In this way one has access (from the upper side) to the battery box C (fig. 5).
- Insert the battery on the box: first the lateral ones A (fig. 6) and then the central ones B (fig. 6).

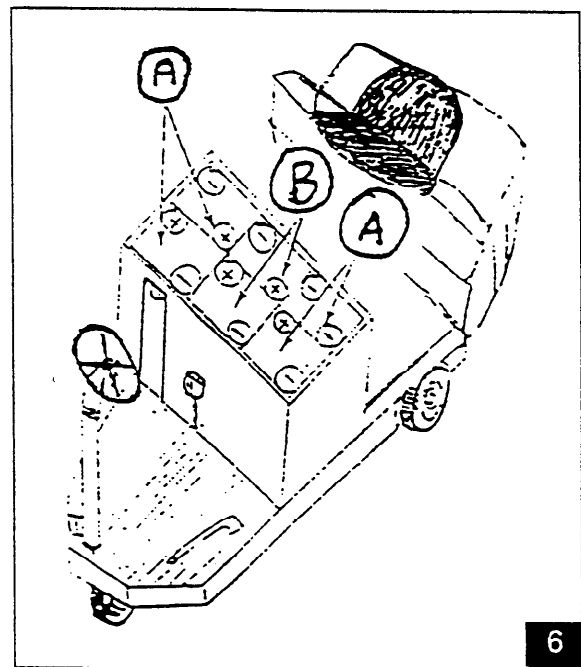

WARNING

When lifting the batteries, remember that they weigh up to 46 kg each.

4.5.3 Connecting the batteries (fig. 7)

**DANGER**

Scrupulously follow the indications described below, as short-circuit of the battery may cause them to explode.

Before fitting a clamp finally onto a pole, touch it against the pole for a moment. If there are any sparks the connection is wrong.

The positive and negative poles have different diameters; fit the clamp marked with the respective polarity onto each pole.

When connecting the batteries, fit the cables as shown in the figure.

- Tighten the bolts on the clamps and cover them with grease.
- Insert back the tank in its work position and hook the tank lever block A (fig. 5).
- Connect the connector A to the one on the machine B.

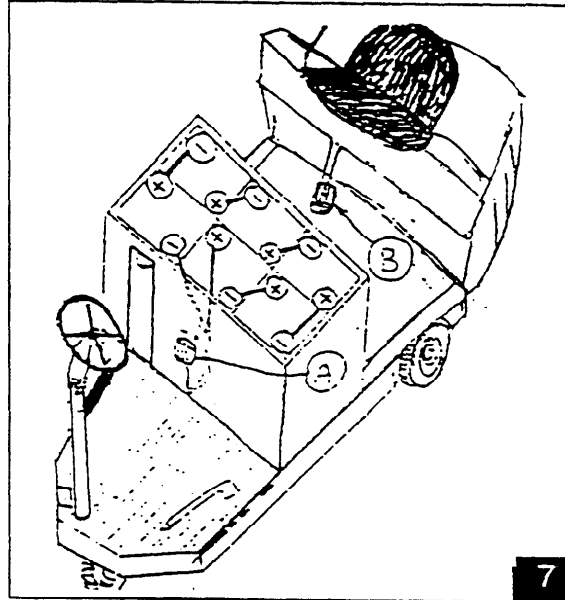

4.6. RECHARGING THE BATTERIES

**WARNING**

If the warning lamp D (§ 6.1., fig. 1) is flashing proceed immediately to recharge the batteries, so that they will not be irreparably damaged.

4.6.1 Choosing the battery-charger

Check that the battery-charger is compatible with the batteries to be charged:

Tubular lead batteries.

The battery-charger must have a maximum initial current of 16 A (with the DIN Wa method) or from 20 to 50 A (with the DIN Wo Wa two-stage method) for each 100 Ah (5) of the battery.

To confirm your choice, consult the Manufacturer and the manual of the battery-charger.

Gel batteries.

Use a battery-charger specifically intended for this type of battery.

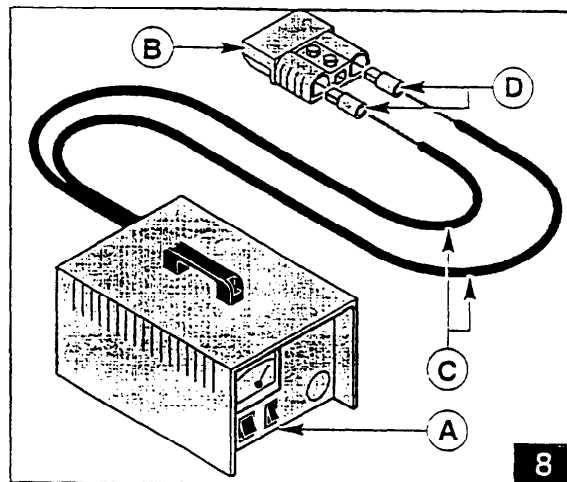

Installing the battery-charger (fig. 8)

Following the instructions enclosed with the connector **B**:

- remove about 13 mm of sheath from the black and the red cable **C**;
- clip the connector terminals **D** onto the cables **C**;
- Insert the terminals in the connector **B**, respecting the polarity: red cable +, black cable-

**DANGER**

Incorrect connection of the battery-charger may cause severe damage to the batteries and, in some cases, may even cause them to explode.

4.6.2 Batteries - Recharging procedure**a) Recharging with the machine switched off:**

- Disconnect the connector **A** (fig. 7) from **B** (fig. 7).
- Proceed as indicated on point c) or d).

b) Recharging with the help of a second battery box and of a battery locker (fig. 9):

- Position the machine beside the battery locker (as closed as possible), respecting the alignment between the yellow labels **A** and **B** (located respectively on the machine chassis and on the battery locker).
- Disconnect the connector **A** (fig. 7) from **B** (fig. 7).
- Verify that the level of the battery locker and the level of the battery box coincide with each other; otherwise operate the battery box level regulation turning the nut **C**.
- Turn clockwise the lever **D**, in order to unblock the battery box.
- Extract the battery box **E** and bring it slowly in position **F**.

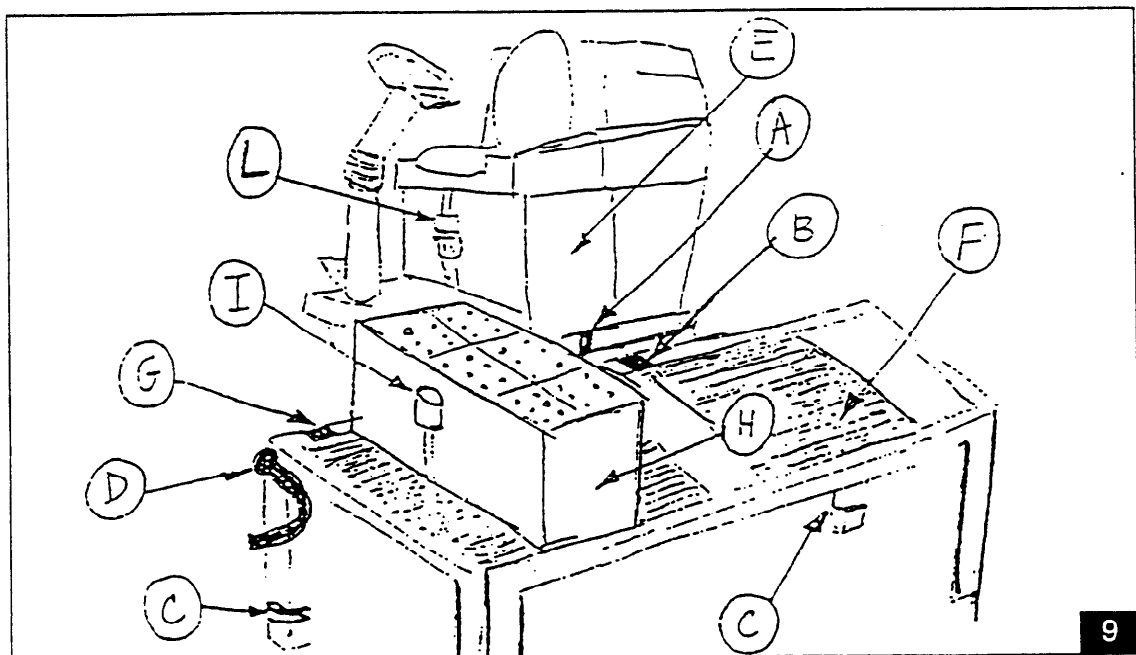

9

- Turn anticlockwise the lever **D**.
- Push forward the machine until obtaining the alignment between the yellow labels **A** and **G** (located respectively on the machine chassis and on the battery locker).
- Turn clockwise the lever **D**.
- Push slowly the box **G** inside the machine.
- Turn anticlockwise the lever **D**.
- Connect the connector **I** and **L**.
- For recharging the battery on the box left on the battery locker, proceed as indicated on point c) or d).

c) Lead batteries with liquid electrolyte (fig. 10)



WARNING

Perform the operations described below only after having taken the machine into a ventilated environment, far from fires, sparks, lit cigarettes ...

- Connect the connector **E** to the connector **B** on the battery-charger.
- Recharge following the indications in the manual of the battery-charger.

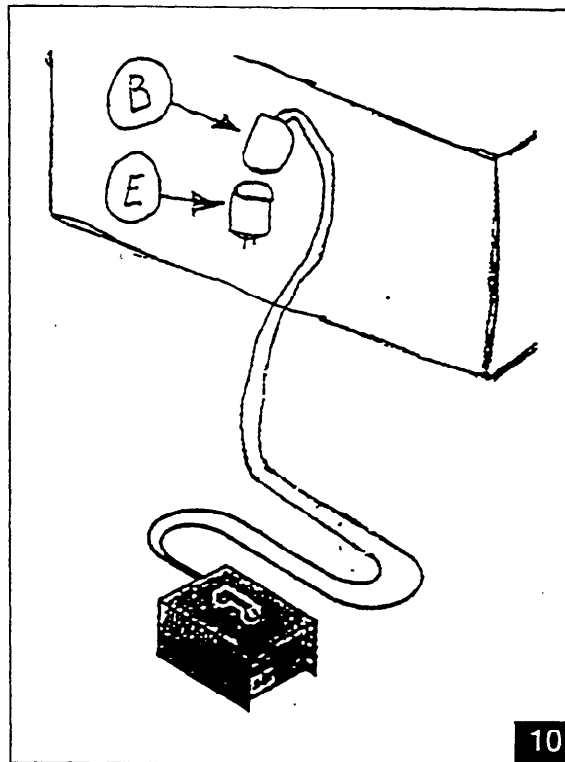

WARNING

Do not let the temperature of the electrolyte exceed 45° during recharging.

- At the end of the recharging time, check the intensity with a densimeter. If one or more elements is flat and the remaining ones are completely charged, the battery is damaged and must be replaced.
- Check the electrolyte level and top up with distilled water if necessary.

- Connect the connector **E** to the one on the machine **L** (fig. 9).
- d) **Gel batteries** (fig. 10)
 - Connect the connector **E** to the connector **B** on the battery-charger.
 - Recharge following the indications supplied with the battery-charger.
 - At the end of the recharging time, disconnect the connector **E** (fig. 10) and reconnect it to the one on the machine **L** (fig. 9).

4.7. LIFTING AND HANDLING OF THE MACHINE (fig. 11)

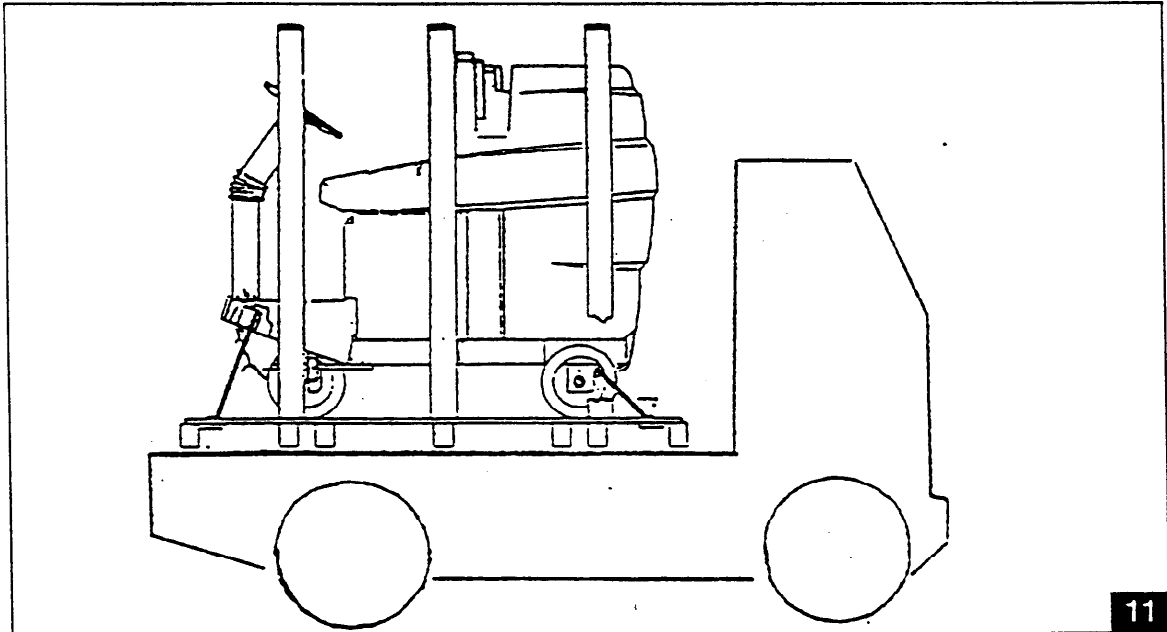

WARNING

The machine weighs about 320 kg.

The loading of the machine onto a vehicle must be done as follows:

- remove the batteries.
- empty the tank and the dirt collecting box.
- remove the squeegee.
- put the machine on the pallet and pull the hand brake.
- fix the machine on the pallet with a bracket (§ 4.3., fig. 3).
- Lift the pallet (with the machine) by means of a fork lift truck, and load it on the way of transportation.
- Anchor the machine to the way of transportation with ropes connected to the pallet and to the own chassis of the machine.
- Loading and unloading of the machine from the way of transportation must be carried out in a suitably lit environment.

5

SETTING UP

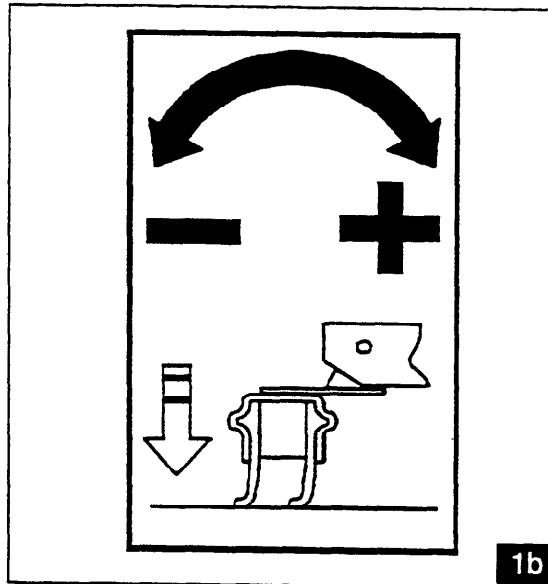
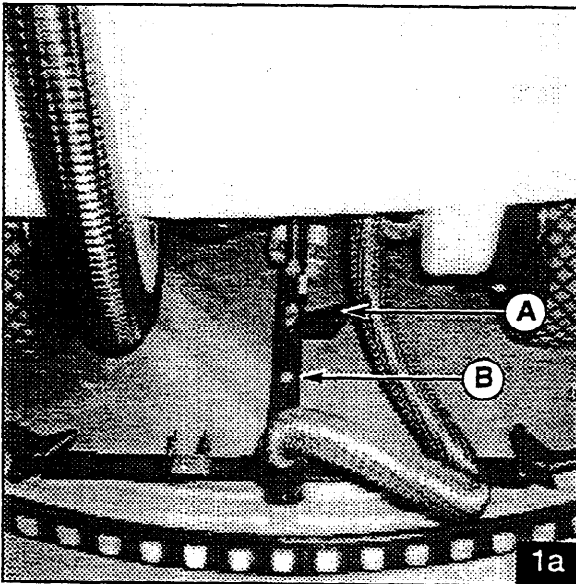

5.1. SQUEEGEE - ADJUSTMENT (fig. 1a and fig. 1b)

To obtain perfect drying, the squeegee must be adjusted so that during operation the rear blade inner lip F (§ 7.2.4., fig. 4) flexes by about 45° compared to the floor.

- A - Pressure adjusting lever (fig. 1a, rif. A): turning it to the right increases the pressure, turning to the left decreases the pressure (fig. 1b);
- B - Inclination adjustment screw (fig. 1a, rif. B): keep the nut locking the screw B still with a 13 mm spanner and turn the screw itself with another 13 mm spanner; turning the spanner clockwise increases the inclination of the blades at the centre of the squeegee and decreases at the sides; instead, when it is turned anti-clockwise, blade inclination increases at the sides of the squeegee and decreases at the centre.

5.2. STEERING COLUMN - REGULATION (fig. 2)

- Slacken the inclination column regulation lever A.
- Regulate the steering B, to have a comfortable drive position.
- Block the inclination column regulation lever A.

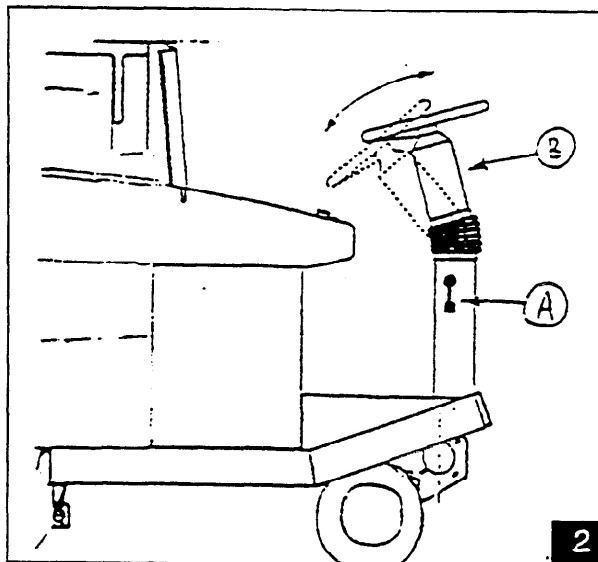

5.3. DRAINING OFF DIRTY WATER (fig. 3)

**WARNING**

The fluids recovered contain detergents, disinfectants, water, organic and inorganic material recovered during operation; they must be disposed of according to the laws in force in the areas concerned.

**DANGER**

Use the individual protection devices listed in § 5.7.

- Take the machine next to a drain.
- Detach the drain hose **A** from its seat and position the cock over the drain.
- Remove the drain cock **B** unscrewing.
- Once all the contents of the tank have been drained off, turn off the cock and put the hose back in position.

For complete cleaning, before closing the cock **B**:

- Remove the tank cover **C**.
- Release the tank block lever **A** (§ 4.5., fig. 5).
- Lift the tank **B** (§ 4.5., fig. 5).
- Wash the inside of the tank.
- Insert back the tank in its work position.
- Hook the tank block lever.
- Put back the tank cover.

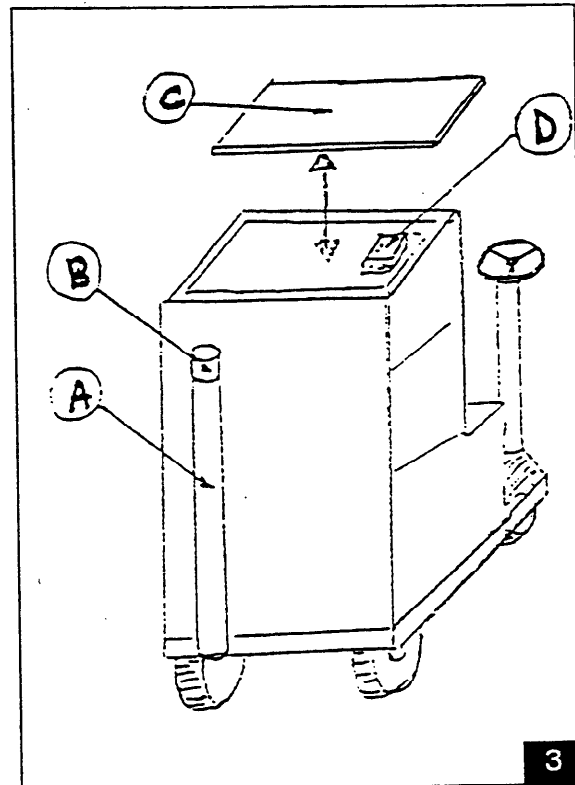
**WARNING**

During the washing do not remove the filter detergent solution **D** (fig. 3) and do not direct the water-jet towards the filter itself.

5.4. DRAINING AND FILLING WITH WATER AND DETERGENT SOLUTION

**DANGER**

Use the individual protection devices listed in § 5.7.

Drainage (fig. 4)

- Go to the area in which you want to empty the liquid.
- Remove the cover **A**.
- Detach the hose **B** and position it over the drain.
- Turn on the scrubber and turn to "1" the accessory Combi switch **X** (§ 6.1, fig.1). When the solution is ended turn to "0" the Combi accessory (§ 6.1, fig. 1);
- Put hose **B** back in position and put back the cover **A**.
- The water and detergent solution may also be used for washing the dirty water tank.

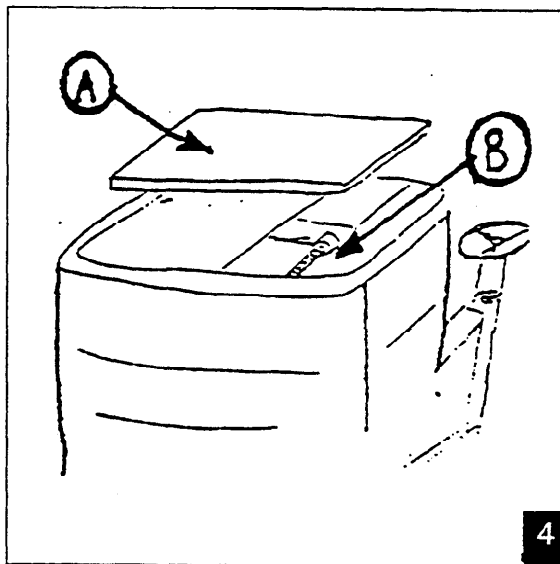
**Filling** (fig. 5)

To fill the diaphragm tank:

- Remove the cover **A**.
- Check that the recovery tank is empty; if it is not, empty it (§ 5.3.).
- Enlarge the diaphragm sack if it does not adhere properly to the tank.
- Fill the sack with the solution of water and detergent, without exceeding the maximum level indicated by the mark **D**.
- Replace the cover **A**.

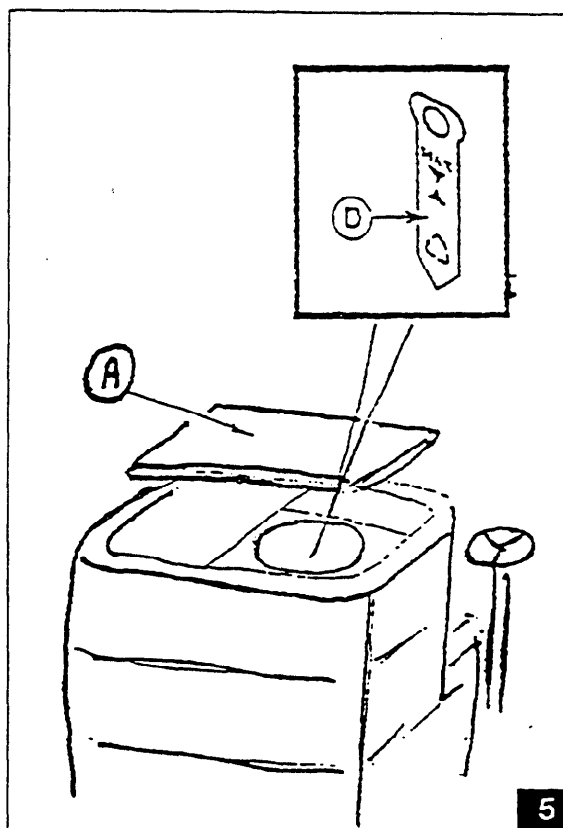

5.5. DIRT COLLECTING BOX - REMOVING AND FITTING (fig. 6)

**WARNING****Do not work unless the box is perfectly installed.**

Before removing the box, stop the machine, wait until the head has come all the way up and the brushes have stopped; then press the emergency button.

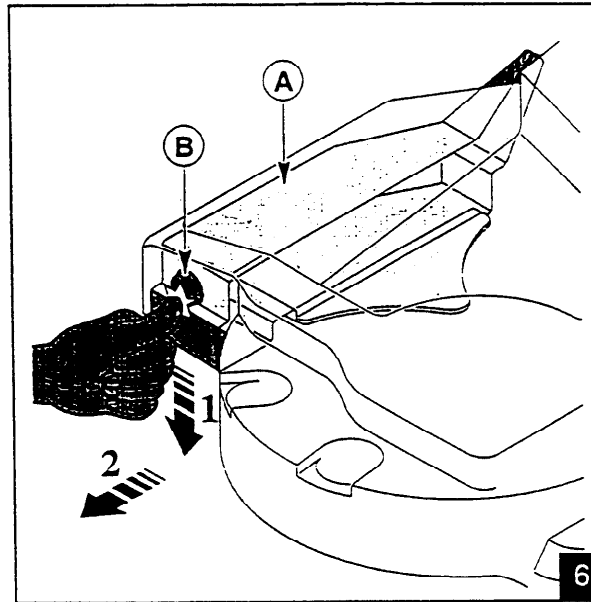

- Press the release button B.
- Lower and remove the box A.

To fit the box, repeat the operations described for removal in inverse order.

5.6. BRUSHES - INSTALLATION

**WARNING**

Do not work unless the brushes are perfectly in place.

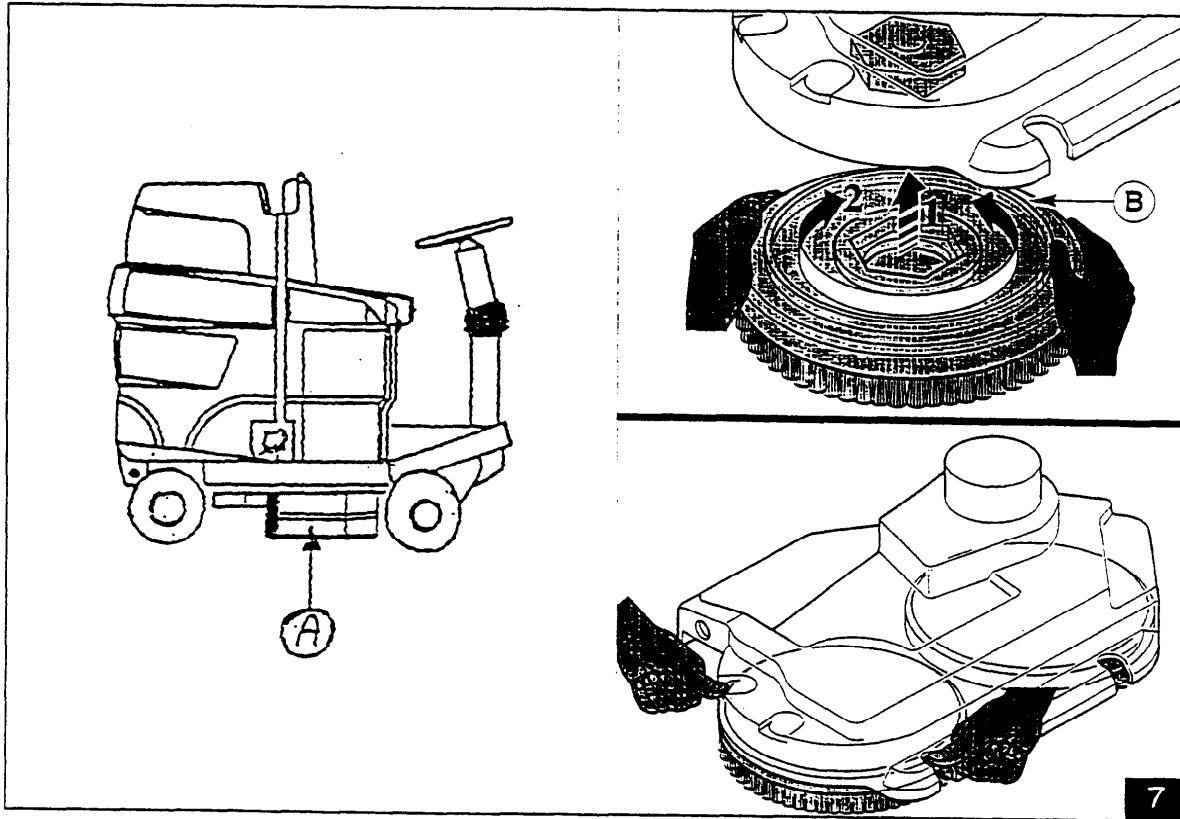

Before removing the brushes, switch off the machine, wait until the head has come all the way up and the brushes have stopped; then press the emergency button and disconnect the battery connector A (§ 4.5.3, fig. 7).

Removing

- Watch out: Open the side right door A to better disassemble the right brush.
- Press the top of the edge of the brush B down with both hands.

Fitting

- Grip the brush B at the sides with both hands.
- Centre the hexagonal socket on the brush with the outline of the brush cover.
- Press upward and turn gently until the brush makes connection.
- To use the abrasive disc, preassemble the drive disc and then fit it on the machine.

5.7. PREPARING THE MACHINE FOR WORK**DANGER****During machine preparation, wear:**

- non-slip waterproof shoes;
- a mask to protect your breathing;
- overalls;
- waterproof gloves;
- any other form of protection recommended by the supplier of the detergent or necessary for the environment you are working in.

Before starting work, perform the following operations:

- check the level of the battery charge and recharge if necessary;
- check that the battery connector is connected;
- check the contents of the recovery tank and drain it if necessary;
- if necessary, empty the dirt collecting box;
- pour clean water and detergent in a suitable concentration into the detergent solution sack (do not pour water into the recovery tank);
- check that the tank cover is perfectly closed (imperfect closing may considerably reduce the machine's drying power);
- fit brushes, drive discs of a suitable type for the floor and the job to be done;
- check that the squeegee is firmly fixed, connected to the suction hose and correctly adjusted;
- ensure that the rear blade of the squeegee is not worn.

6

USE

6.1. DESCRIPTION OF THE CONTROLS

– Control panel. (fig. 1)

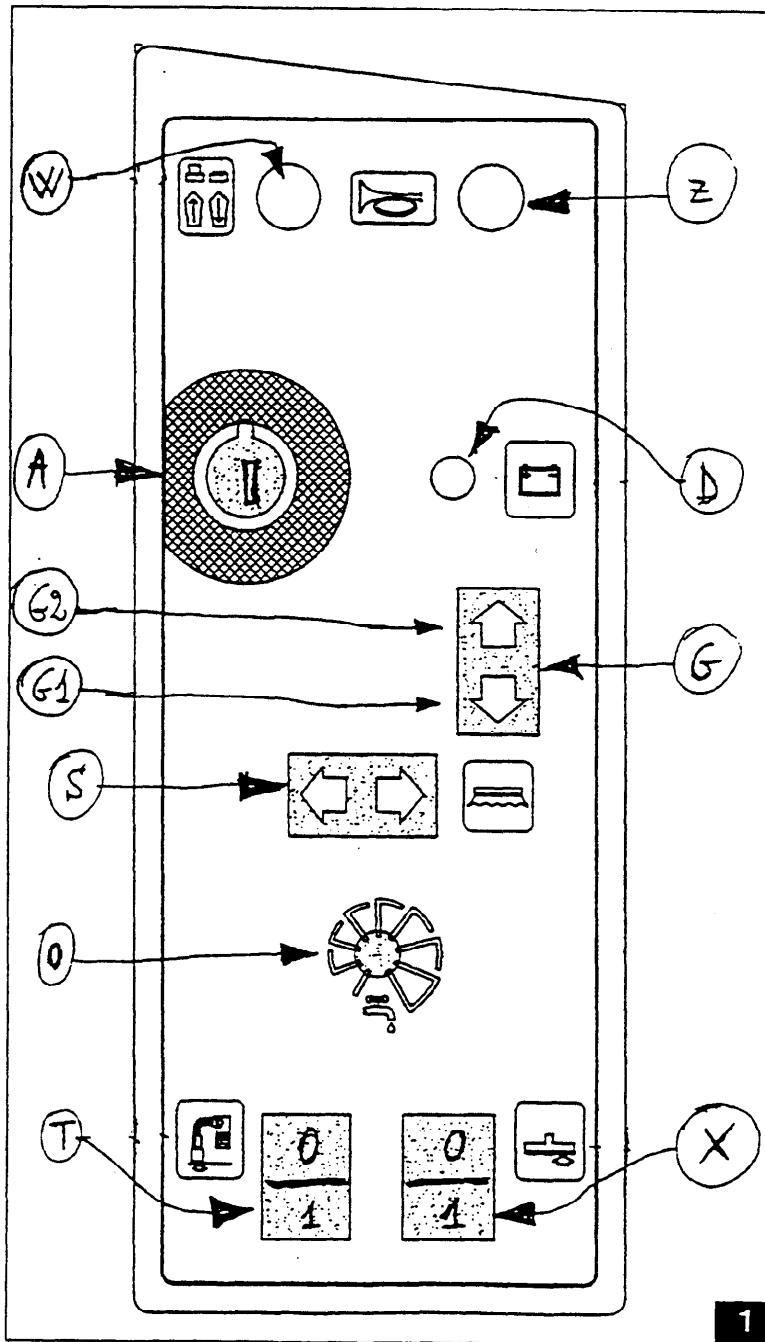

A - Main switch - emergency button with key

Switches on and off the electric power supply to the machine.

- Press the button to stop the machine. Use the ignition key to restart the machine.

D - Warning light (red).

Shows that the power supply has been activated and indicates the level of the battery charge:

off: the machine is off;

flashing at a steady frequency: the machine is on but the batteries are almost flat and must be recharged immediately because they may be irreparably damaged if you keep working with the machine.

lit: the machine is switched on.

G - Lifting - Lowering of brushes button:

- the "G1" position: operates the lowering of head in working conditions and the rotation of brushes .
- the "G2" position: stops the brushes and lifts the head in a standing position.

O - Potentiometer of solution pump.

Adjusts the flow of solution (clean water and detergent). By rotating clockwise, it increases the flow of solution .

S - Button lateral shifting of sweeping head.

It works only when the lateral device is installed in the machine.

- by pushing it on the right, the head comes out;
- by pushing it on the left, , the head comes in again;

T - Vacuum button with warning light.

Turns on and off the vacuum motor, which dries the floor on which the operator works. The warning light is active if the vacuum motor is fed.

W - Forward/reverse running selection button.

- With key released the light (on the key) is off and the forward running is activated.
- With key pressed the light (on the key) is off and the reverse running is activated.

X - Switch of Combi accessory with warning light:

- "1":it commutates the scrubber to the accessory;the brushes are stopped (if the same were running)and the solution pump starts;
- "0": it puts off both the vacuum motor and the solution pump.

Z - Button of acoustic horn.

- the horn gives out continous spound, when the botton **Z** is pushed ;
- the horn gives out a sequence of short sounds (0,5 sec. ON, 0,5 sec. OFF) when the scrubber is on reverse;
- the horn gives out a continous sound , when the manual brake is "on" (with the machine operating) .

6.2. SQUEEGEE - USE

- Push "1" on the switch T (§ 6.1. fig.1), to operate the vacuum motor .
- Operate the pedal B (fig. 2) to lower the squeegee A (fig. 3).
- If during the work, with the squeegee down , the operator wants to go reverse, first he must stop and then he must lift the squeegee. On the contrary, the horn gives out a continuous sound and the driving T is prohibited (§ 6.1, fig. 1).
- At the end of work, operate on pedal B (fig. 2) to lift the squeegee A (fig. 3).
- Push "0" on the switch T (§ 6.1, fig. 1) to lower the vacuum motor.

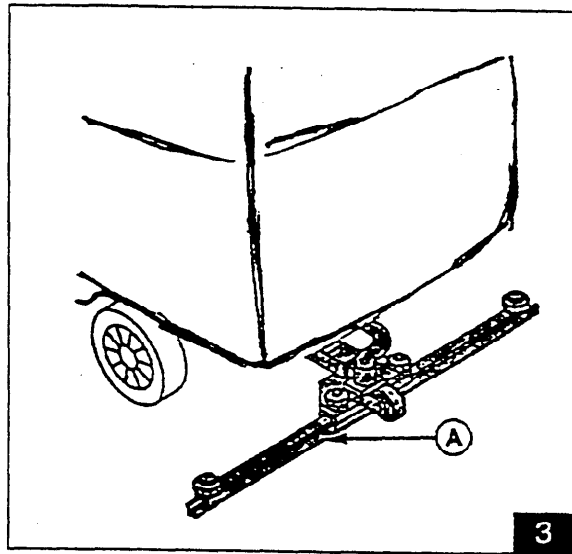
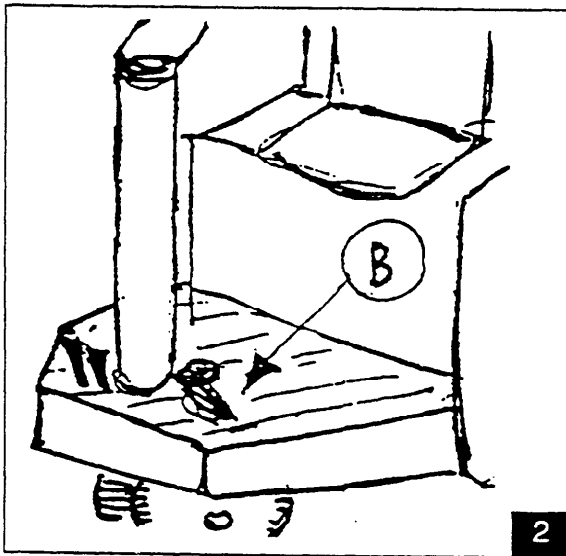

6.3. PARKING BRAKE - USE



WARNING

Do not leave the machine unattended with the parking brake disengaged. Do not engage the parking brake when the machine is moving.

To engage the parking brake:

- ensure that the machine is standing still;
- raise the lever B (§ 2.6., fig. 4);

To disengage the parking brake:

- press the button on the hand brake lever extremity and lowering the lever.

If the accelerator is pressed with the hand brake on, the horn warning produces an intermittent sound.

6.4. DRIVING THE MACHINE

- After being seated on the driver seat, move the machine and regulate the speed act on the accelerator.
- To insert the reverse driving, first stop, make the squeegee lift up, by operating the pedal **B** (§ 6.2., fig. 2) and then push the button **W** (§ 6.1., fig. 1).
- To decelerate release the accelerator: the motor works as an electromagnetic brake speeding down the machine with a graduate braking; to emphasize the braking act on the pedal.

6.5. PROCEDURES FOR USING THE MACHINE



DANGER

Before starting work you are advised to wear:

- overalls;
- non-slip waterproof shoes;
- a mask to protect your breathing;
- waterproof gloves;
- any other form of protection recommended by the supplier of the detergent used or necessary for the environment you are working in.

After having prepared the machine as described (§ 5.7.), proceed as follows:

- insert and turn the key to release the mushroom button, remove the key and place it in the compartment on the arm rest on the left of the operator;
- rotate the solution pump potentiometer **O** (§ 6.1., fig. 1) to the minimum position (solution minimum flowing);
- push "1" on the switch **T** (§ 6.1., fig.1), to start the vacuum motor;
- lower the squeegee with the pedal **B** (§ 6.2, fig. 2) and, when necessary, adjust it (§ 5.1.);
- press the up/down brushes button **G** (§ 6.1., fig. 1), on the position **G1**. The brushes lower and begin turning, while the pump spreads detergent solution on the floor;



WARNING

the set pressure must be suitable for the type of floor you are working on; too high a pressure could damage the floor;

- release the parking brake (if it is on);
- adjust the traction speed acting on the accelerator ;
- while working with the squeegee down, if the operator wants to put the machine in reverse, it's necessary first to stop and then lift the squeegee;
- check periodically that the solution arrives to the brushes, and fill the tank when empty;
- while working, check the cleaning quality and, when necessary, adjust the flow of the detergent solution by rotating the potentiometer **O** (§ 6.1, fig. 1);

- stop to adjust, if necessary, the squeegee inclination;

**WARNING**

never leave the machine standing still with the head down and the brushes moving: you could damage the floor.

- when the warning light **D** (§ 6.1., fig.1) on the control panel begins blinking, the batteries are near to be discharged, and therefore their recharge is necessary, because, in this case, there's no device which stops the complete functioning of the machine;
- when the warning light **D** (§ 6.1., fig.1) sends sequences of blinkings with pauses of about 2 sec., the floating is closing the vacuuming. It is necessary to empty the recovery tank (§ 5.3.);

After finished work:

- stop the machine and switch on the hand brake;
- press the "brush up" button **G** (§ 6.1., fig. 1) in the position **G2** so to stop and lift the brushes;
- leave the suction motor on for at least two minutes with the tank cover open, to make sure that the suction device is dry;
- press the main switch **A** (§ 6.1., fig. 1) to switch off the power supply to the machine.

6.6. EXTRACTABLE HEAD - USE

When this accessory is fitted, start the machine and proceed as follows:

- lower the head;
- press the "head side movement" button **S** (§ 6.1.);
- when working, be careful not to bump hard against the feet of shelves or other furniture to avoid overturning them; the head comes in when it meets obstacles and comes out again automatically when they are passed.
- to guarantee a correct drying by the squeegee, avoid (if possible) sudden turnings on the left.
- to bring inside the head press again the "head side movement" button **S**.

6.7. RECYCLING SACK ACCESSORY - USE (fig. 4)

The accessory recycling sack allows to extend work to autonomy and to reduce the consumption of detergent recovering, with an opportune filtering, the water intake from the floor and sending it again to the brushes.

To install the accessory, consisting of a frame **A** and of a recycling filter sack **B**, proceed as follows:

- if the diaphragm sack is present in the tank, remove the pump **A** (§ 7.2.7, fig. 7) from the sack and take out the diaphragm sack **B** (§ 7.2.7, fig. 8) from the tank;
- dress the frame **A** with the recycling sack **B**;
- tie the strings **C** to the frame **A** to fasten the sack to the frame;
- put the frame and the sack **D** inside the tank;
- hook the frame in the adapt holds inside the tank;
- put the pump inside the filter.

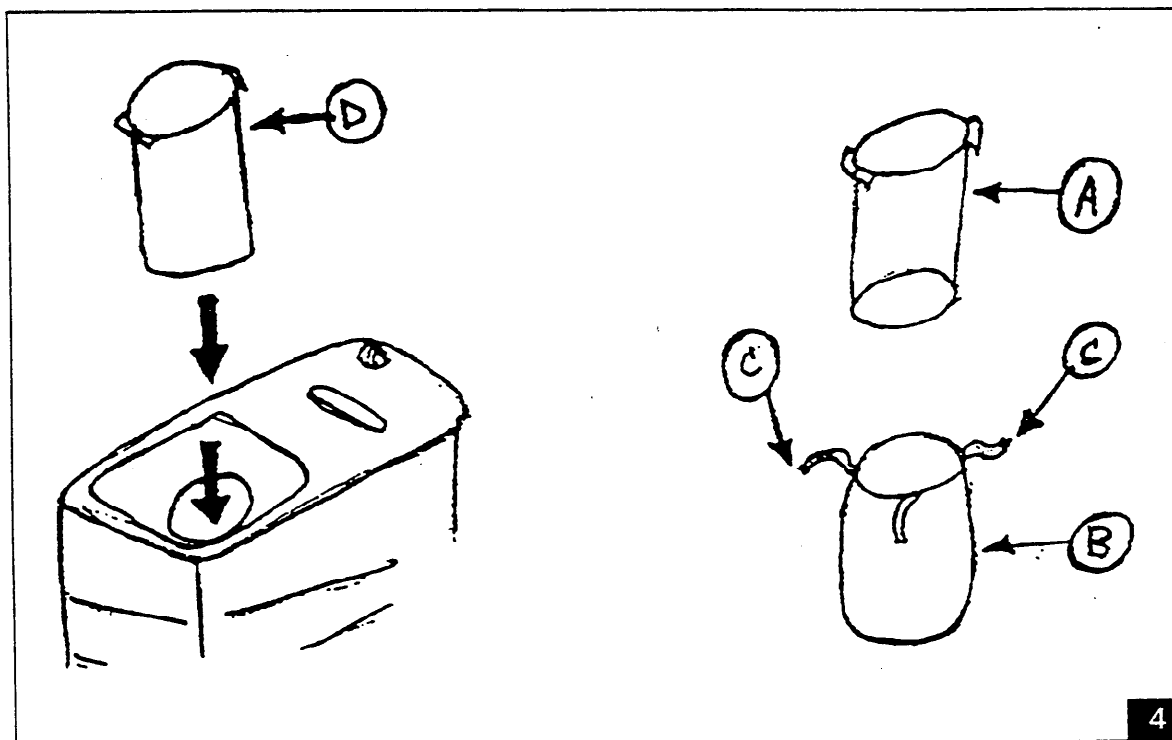

6.8. COMBI ACCESSORY - USE (fig. 5)

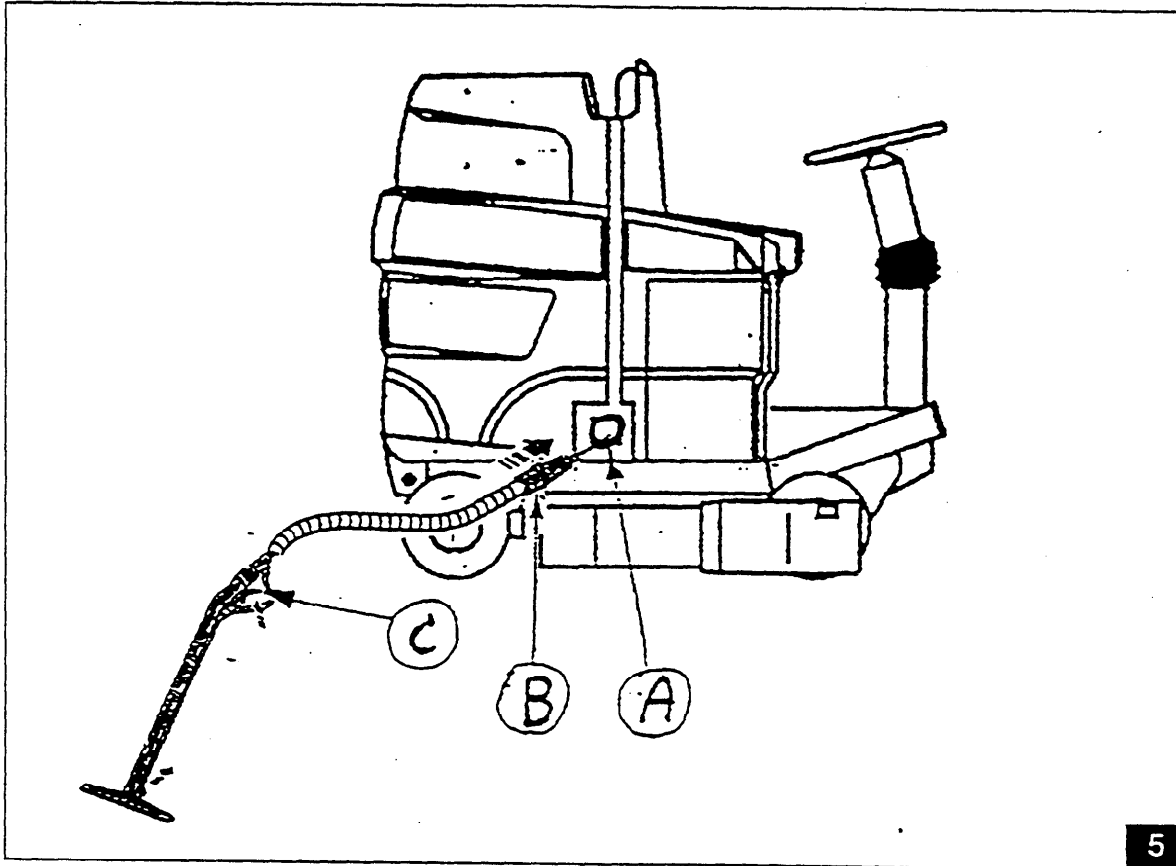

This accessory allows the machine to wash in inaccessible positions such as corners, stairs, cluttered floor areas.

Use the accessory as follows:

- stop the machine and apply the parking brake;
- when brushes are running, push the button **G** (§ 6.1., fig.1), in the position **G2**, to turn off the brush motor and lift the head;
- lift the cover **A** and insert the coupling **B** as far as possible with the air passage hole facing upwards;
- close the cover **A** on the coupling **B**;
- ensure that the diaphragm sack for the solution of water and detergent is not empty;
- push "1" on the accessory Combi **X** (§ 6.1., fig.1);
- spray on the detergent solution, pulling the lever **C** and rub the floor with the bristles to remove the dirt;
- suck up the dirty water, sliding the squeegee over the floor and using the part with rubber blades;
- after finishing the cleaning, push "0" on the switch of Combi accessory **X** (§ 6.1., fig.1)

**WARNING**

Never leave the machine unattended with the pump and/or the suction unit operating.

6.9. SWEEPING HEAD ACCESSORY - USE

The sweeping head accessory is ahead of the front wheel and collects the coarse dirty.

Assemble the accessory as follows:

- place the sweeping head on the front of the machine (fig. 6);
- set in line the hinges **A** e **B** set respectively on the frame and on the accessory, as shown on tab. 6.
- fix the accessory to the machine through the pivots **C** (fig. 6).

To disassemble the sweeping drawer **E** (fig. 6):

- stop the machine;
- lift the head, if the same is working;
- push "O" on the switch **D**;
- wait that the brushes are motionless;
- push the emergency button;
- lift the sweeping drawer **E** using the handle **F**.

You can adjust the height of brushes on the the floor by adjusting the position of screws **G** (fig. 6) referred to the button-holes **H** (fig. 6).

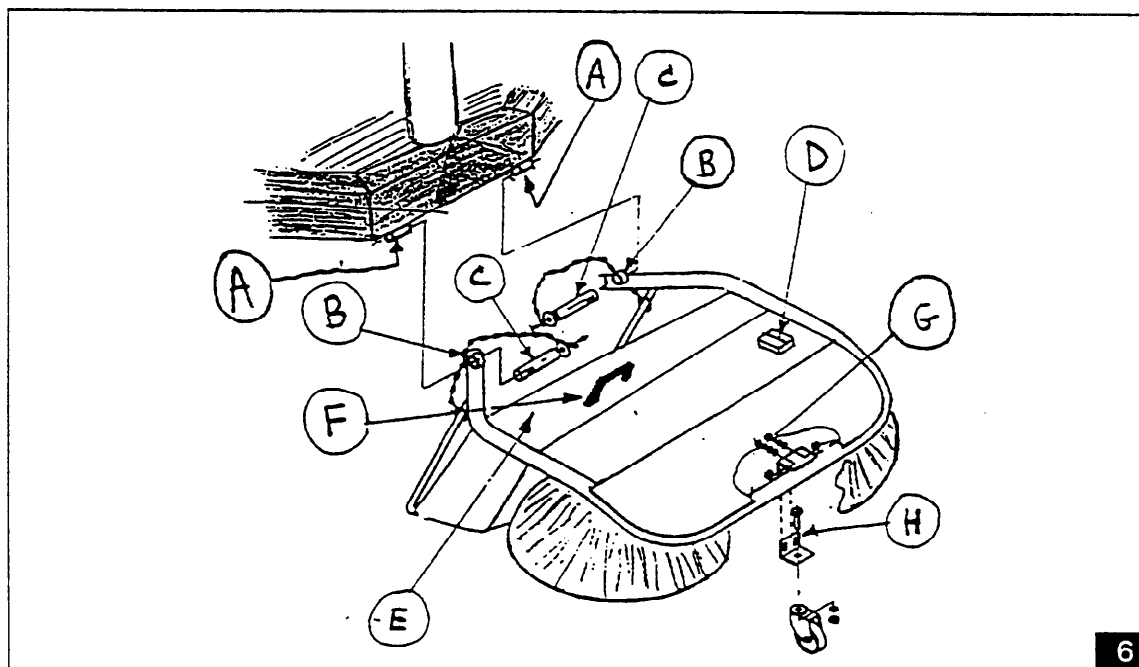

6

6.10. HOURMETER ACCESSORY - USE

The hourmeter accessory **A** (fig. 7) is set on the cover of electrical plates room **B** (fig. 7) and shows the operational hours of brushes.

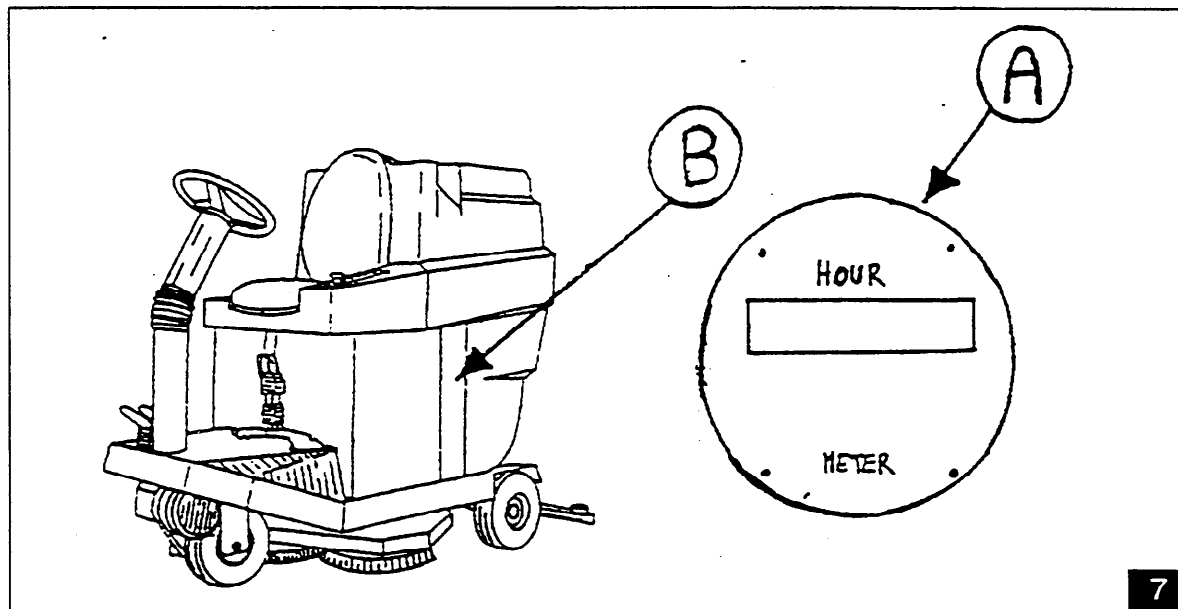
**6.11. ADVICE ON OPTIMUM USE OF THE MACHINE**

If the floor presents a particularly difficult type of dirt, you are advised to wash and dry it in separate stages:

- start washing with the suction unit off and the squeegee raised, insisting particularly on the dirtiest areas;
- go over the floor a second time, after having lowered the squeegee and switched on suction.

For easy use and maximum performance, we advise following work paths that are as straight as possible, eventually finishing off quickly with a mop or cloth or, better still, with the Combi.

7

MACHINE MAINTENANCE

7.1. MAINTENANCE - GENERAL RULES

Regular maintenance, performed according to the Manufacturer's indications, guarantees better performance and longer machine life.



DANGER

Before carrying out any maintenance job, disconnect the battery connector (A) (fig. 1).

The maintenance operations on the electric system, and all those not explicitly described in this operator's manual, must be performed only by skilled technical personnel, in conformity with the safety regulations in force and with the recommendations in the maintenance manual.

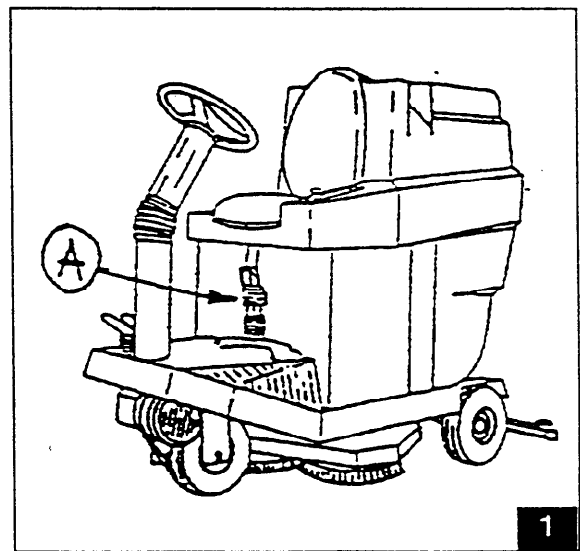

7.2. ROUTINE MAINTENANCE

7.2.1 General cleaning

Clean the machine, avoiding the use of:

- **high-pressure cleaners and jets of water**, which could cause water to get into the electric components, damaging them;
- **steam**, which could cause heat damage to the plastic parts;
- **solvents or hydrocarbons**, which could damage the hoods or the rubber parts.



INFORMATION

Do not use water on the motors or on the electric parts.

Wash periodically (§ 7.3.1) the diaphragm by hand with a brush with soft bristles and water and detergent. The usage of other mechanical (ex. electric brushes, cleaning machines, mechanical brushes) or chemical means (ex. solvents) may damage the sack.

7.2.2 Suction filter - Cleaning (fig. 2)

- Remove the tank cover **C**.
- Remove the filter **D** and clean it with water or with the detergent used in the machine.
- Dry it well before replacing it.

**WARNING**

Do not pour liquids or throw objects into the nozzle **E; you could damage the suction unit.**

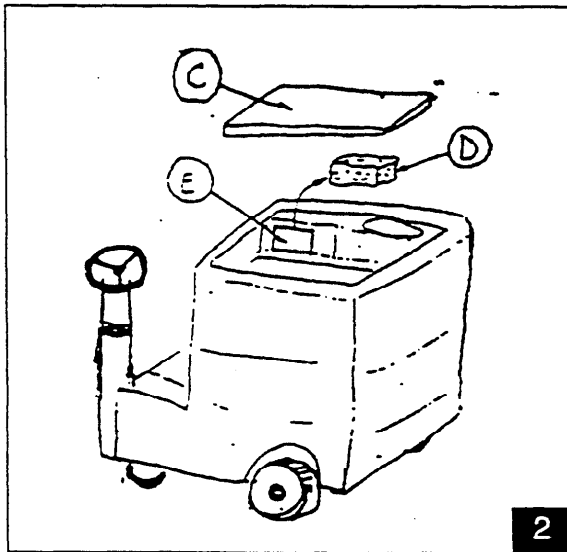
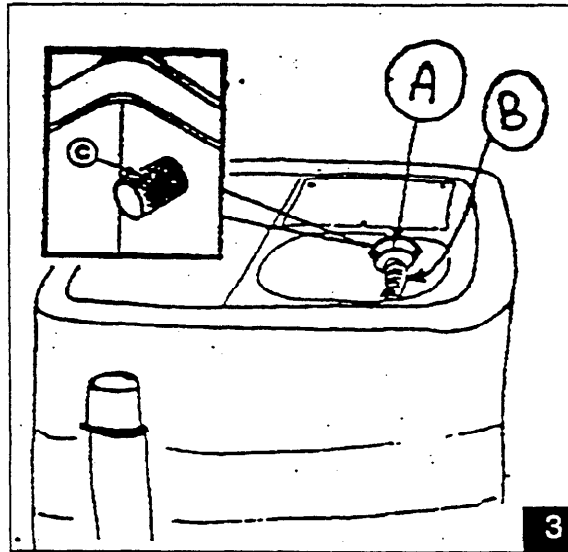
**2****3****7.2.3 Cleaning liquid input hole - Cleaning (fig. 3)**

- Press the white button **A**, extract the hose **B**, clean the input hole **C**.

7.2.4 Squeegee blades - Replacement (fig. 4)

The squeegee is fitted with two blades (fig. 4, **F** and **H**). Both blades are subject to wear and the replacement of them is performed in the following manner:

Exchanging the blades

- Unscrew the knobs **C**.
- Disconnect the sleeve from the mouth **D**.
- Remove the squeegee.
- Unscrew the knobs **A**.
- Extract the bumpers **B**.
- Release the reinforcing blades **E** (a/o **I**) to remove the blades **F** (a/o **H**).
- Extract the blade **F** (a/o **H**) from the body **G**.

Squeegee reassembly

- Refit the blade **F** (a/o **H**) to the squeegee body **G**.
- Refit the reinforcing blades **E** (a/o **I**).

- Put the bumpers B back and fix them with the knobs A.
- Insert the squeegee on the support slots and tighten the knobs.
- Finally connect the sleeve to the mouth D.

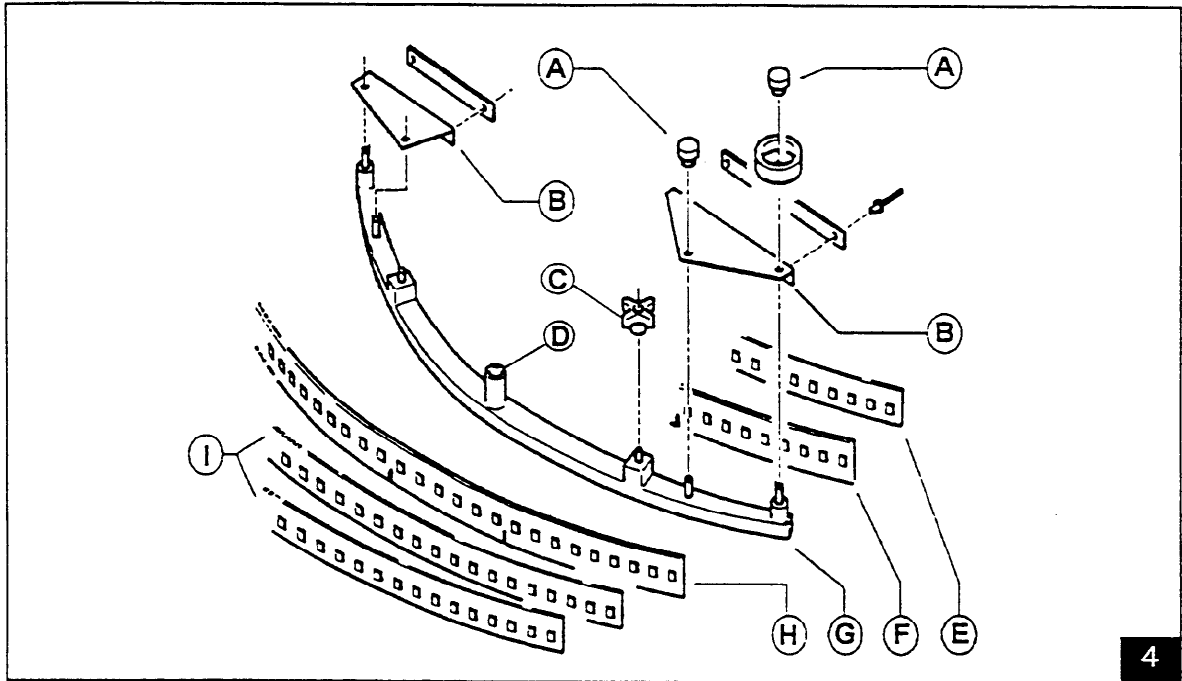

7.2.5 FLAPS - Replacement (fig. 5)

This operation must be performed when the flaps on the head are worn or damaged, proceeding as follows:

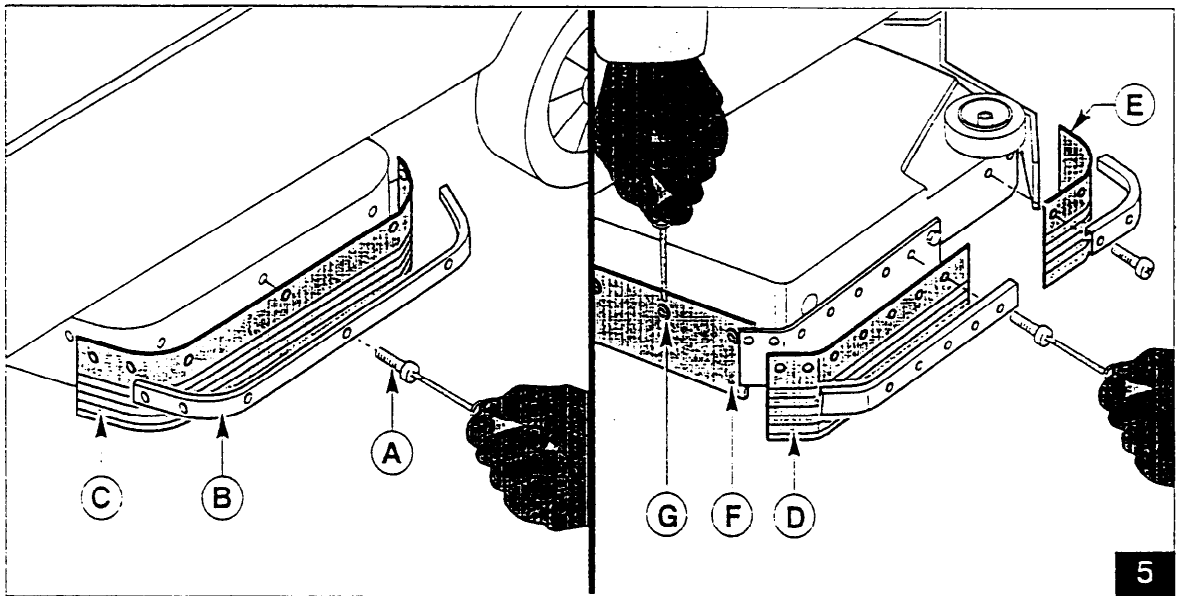

- Unscrew the screws A.
- Remove the flap-pressers B.

- Change flap **C** and put the flap-presser **B** back in place.
- Bring out the head by pressing the button **S** (§ 6.1.) and press the emergency button.
- Change flap **D** and **E** as described above.
- Change flap **F** after having released the clips **G**.
- Use new clips to fix the flap.

7.2.6 Dirt collecting scraper - Replacement (fig. 6)

The dirt collecting scraper enables the dirt carried along by the brushes to be guided into the collecting box.

If it is damaged, replace it as described below:

- slip out the dirt collecting box **A**.
- replace the damaged scraper with a new one **B** positioning the latter with the wide end **D** towards the machine and the narrow end **C** outwards.

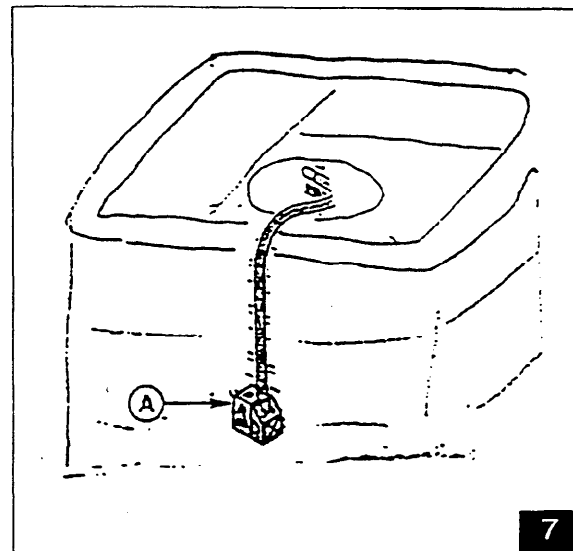
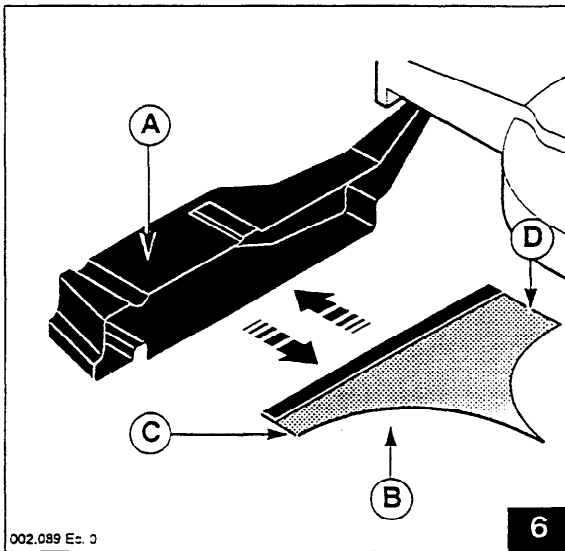

7.2.7 Diaphragm sack - Replacement

In the event of breakage of the diaphragm sack, replace it as follows:

- remove the pump **A** (fig. 7) from the diaphragm sack;
- unhook the frame **C** (fig. 8) and slip out the diaphragm sack **D** (fig. 8);

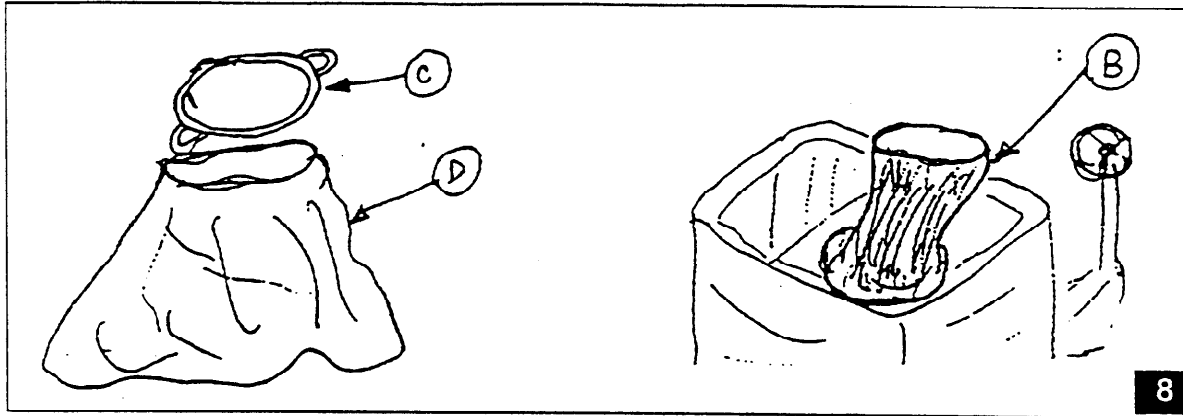

- fit the frame C in the new diaphragm sack D as in fig. 8 (alternatively, a diaphragm sack with pre-fitted frame is available as spare);
- insert the diaphragm sack, ensuring that it opens up to fill the tank;



WARNING

**Perform this operation accurately!
Otherwise the sack could be irreparably damaged.**

- Hook the frame C onto the tank;
- insert the pump in the diaphragm sack, ensuring that it reaches the bottom.

7.2.8 Recycle accessory - Cleaning and replacement

Periodically, when necessary, clean the recycle filter sack, proceeding as follows:

- remove the pump A (fig. 7) from the filter sack.
- remove the filter sack D (§ 6.7, fig. 4) from the tank and wash it running water.

Whenever the filtering capacity of the filter sack diminishes, proceed to the replacement of the filtering element (§ 6.7).

7.2.9 Float - Cleaning (fig. 9)

- Empty the tank. Remove the tank cover A.
- Remove the suction compartment cover C and check that the float B moves freely.
- If necessary, remove and clean the float.

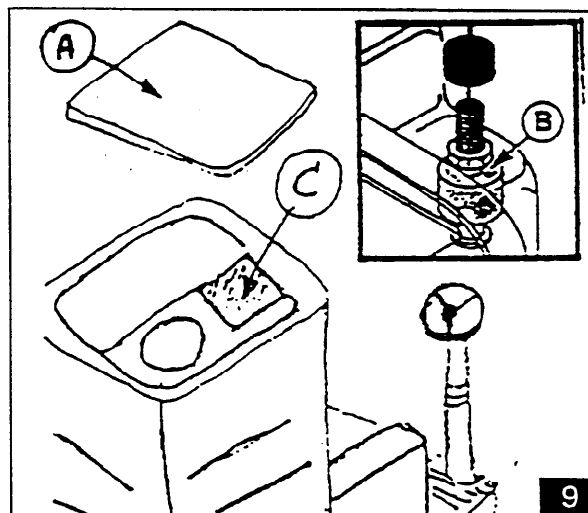

7.2.10 Pump impeller - Cleaning (fig. 10)

- Extract the pump A (fig. 7) from the diaphragm sack.
- Unscrew the screw A and remove the washer B.
- Remove the cover C.
- Extract the filter-impeller unit G from the pump casing F, turning it anticlockwise.
- Clean the impeller E.

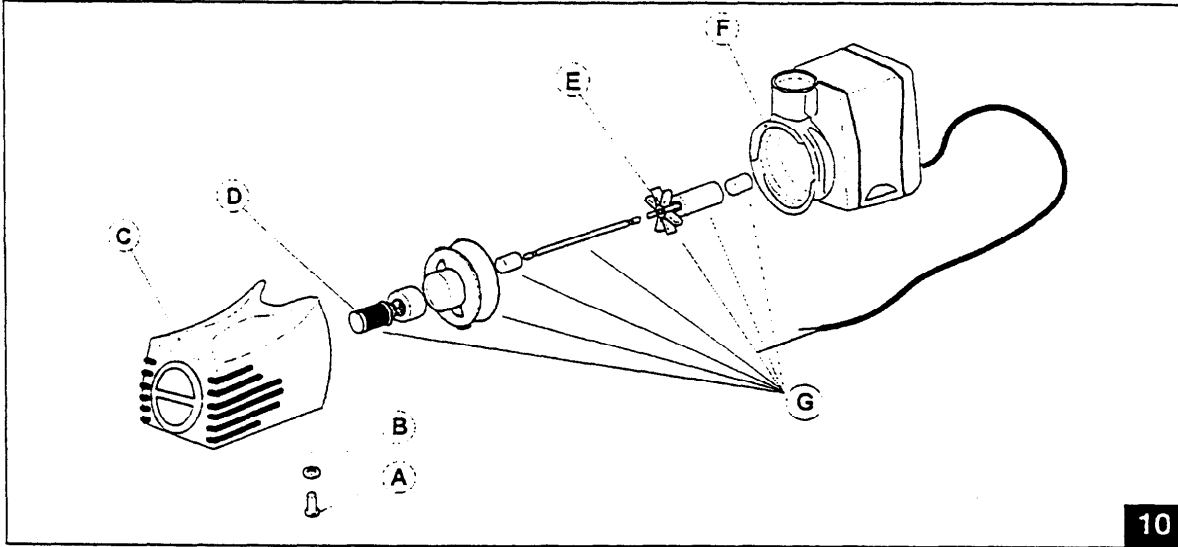

- Clean the filter D.

**WARNING**

Do not spoil the internal surface of the motor winding.

Reassemble, repeating the operations described in inverse order.

7.2.11 Fuses - Replacement (fig. 11)

- Remove the electronic plate compartment cover A.
- Extract, pulling it out, the electric components plate.
- Replace the damaged fuse B (fig. 12).

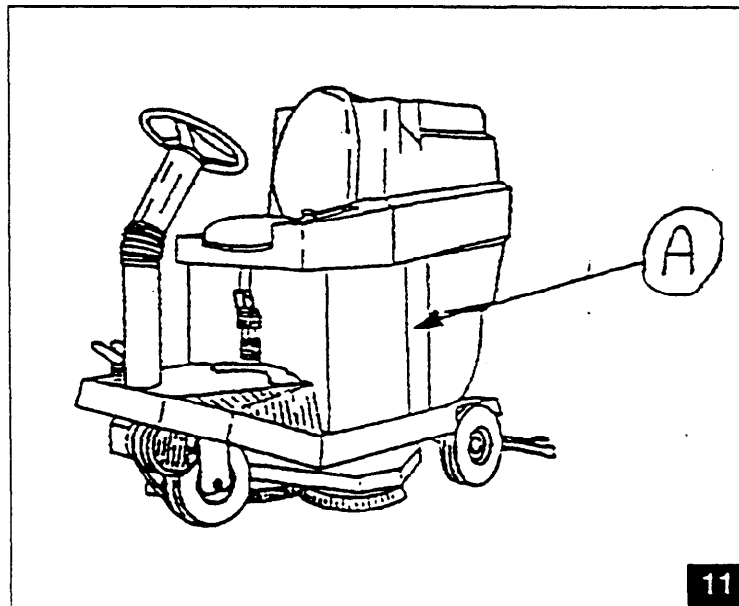

Replacing fuses B (fig. 12).

- Disconnect the connectors **A** (fig. 1).
- Remove the electric plates compartment **A** (fig. 11).
- Extract, pulling it out, the electric components plate (fig. 11).
- Replace the fuse **B** unscrewing the screws **C**.

Fuse chart

For the fuse chart, see the Spare Parts Catalogue.

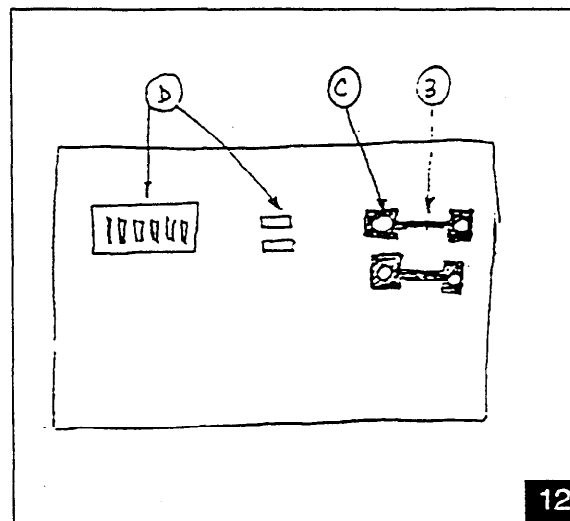

i INFORMATION

Never fit a fuse with a higher Amp value than the intended one.

If a fuse keeps burning out once it has been replaced, it is necessary to identify and repair the causes in the machine, the cards, the motors or the electric cables.

7.3. PERIODIC MAINTENANCE

7.3.1 Daily maintenance

Every day, at the end of work, perform the following operations:

- press the emergency button on the control panel to switch off the machine.
- check that the recovery tank is clean;
- check that the inside of the Combi accessory notch is clean, in particular the zone corresponding to the spherical valve.
- check that the dirt collecting box is empty and clean the water drainage holes;
- check that the dirt collecting scraper is not torn or bent;
- clean the suction motor filter and check that it is undamaged and, if necessary, replace it;
- clean the squeegee blades, checking that they are not excessively worn and are not torn;
- recharge the batteries;
- when putting away the machine, engage the hand brake, press down the emergency mushroom button and put the key in a safe place.

7.3.2 Weekly maintenance

- Check the level of the electrolyte in the batteries and top up with distilled water if necessary.
- Check and clean the cleaning liquid input hole.

- Ensure that the squeegee suction hole is not blocked, freeing it from any encrusted dirt.
- Clean the suction hose.
- Clean the float and check that it is working correctly.
- Verify that the pump and the filter positioned inside it are clean.
- Clean the diaphragm.
- Clean the inside of the Combi accessory notch corresponding to the spherical valve, using a small brush or pointed tool.

7.3.3 Six-monthly maintenance

Have the electric system and calibrations checked by skilled personnel.

7.3.4 Preparing for long periods of inactivity

If the machine is to remain unused for a long time, perform the following operations:

- remove the squeegee, wash it and wrap in a bag or a sheet of plastic;
- remove and clean the brushes and the abrasive discs and put them in a dry place, away from dust;
- empty and thoroughly clean the tank and the sack;
- Remove the batteries and fully recharge the batteries before storing them. Recharge them from time to time (at least once every two months) to keep the batteries constantly at maximum charge.



WARNING

**If the batteries are not recharged periodically
there is a risk of irreparable damage.**

**If the batteries are left on the machine, disconnect the battery connector from
the machine.**

8

TROUBLESHOOTING

8.1. HOW TO OVERCOME ANY PROBLEMS

Possible faults affecting the whole machine.

FAULTS	CAUSES	REMEDIES
The machine does not work.	The battery connector is disconnected.	Connect the batteries to the machine.
	The emergency mushroom button is pressed or faulty.	Insert the key, turn and release the button or change it.
	The main fuse has burnt out.	Check and remove the causes for the burning of the fuse, then change it.
Water is leaking from the diaphragm sack into the tank.	The sack is broken.	Change the sack.

Possible faults affecting the washing and sweeping head.

FAULTS	CAUSES	REMEDIES
The brushes do not turn.	The brush motor remote control switch is faulty.	Change the switch.
The head does not go down on command.	The actuator is faulty.	Change it.
	The fuse F3 has burnt out.	Check and remove the causes for the burning of the fuse, then change it.
The machine does not wash evenly.	The brushes or abrasive discs are worn.	Change them.
The machine does not sweep correctly.	The dirt collecting box has not been fitted, or it is full.	Empty the dirt collecting box and put it in place.
	The dirt collecting scraper is deformed, damaged or missing.	Change the dirt collecting scraper.
The brushes keep turning even when the emergency button has been pressed.	The brush remote control switch is faulty.	Disconnect the battery connector and have the remote control switch replaced.

FAULTS	CAUSES	REMEDIES
The solution is not coming out.	The washing head is not working.	Start the washing head.
	The solution tank is empty.	Fill it.
	The detergent solution sleeve is disconnected.	Reconnect the sleeve.
	The built-in no-return valve in the pump does not close correctly.	Check to see if it is clogged, clean it.
	There is an obstruction in the pipes that carry the solution.	Remove the blockage and clean the pipes.
	The pump is faulty.	Repair or change it.
	The pump card is faulty.	Change it.
Water keeps coming to the brushes even when the machine is switched off	False contact on the pump card.	Repair it.
	The breather holes on the detergent solution sleeve are blocked.	Clean the holes.
The head does not come out at the side.	The head side movement accessory has not been installed.	If not fitted in the factory, this accessory may be installed at an authorized service centre.
	The side movement actuator is disconnected or faulty.	Have the actuator and its connection checked.
	The gas spring is faulty	Have the gas spring replaced.
	There is a mechanical fault in the head.	Have it repaired.
After side movement, the head does not come back into central position.	The side movement actuator is disconnected or faulty.	Have the actuator and its connection checked.
	An obstacle is preventing return.	Remove the obstacle
	There is a mechanical fault in the return mechanism.	Have it repaired.

Possible faults affecting drying.

FAULTS	CAUSES	REMEDIES
The suction motor does not work.	The floater in the tank intervened, is blocked by dirt or is faulty.	Check if the tank is full of dirty water (empty it) or opportunistly intervene in the floater.
	The suction motor does not work even if supplied directly with power.	Change the suction motor.
	The suction/pump card is faulty.	Change the F2 fuse or the pump card.
	The F4 fuse of the suction motor is burnt.	Change the fuse.
The squeegee leaves traces of dirty liquid on the floor.	The inclination and/or pressure of the squeegee is not correctly adjusted.	Adjust the squeegee following the specific instructions.
	The edge of the blade in contact with the floor is worn.	Change the blade.
	There is an obstruction or damage in the squeegee or in the pipe.	Remove the obstruction and have the damage repaired.

FAULTS	CAUSES	REMEDIES
The squeegee does not suck up the dirt.	The tank cover and/or the clean water cover are not perfectly closed.	Close the covers, ensuring that there is a pneumatic seal with the tank.
	The recovery tank is full and the suction unit is not working (intervention of the electronic float).	Empty the tank.
	The overflow float is blocked by encrustations and the suction unit is not working.	Remove encrustations.
	There is a blockage in the suction pipe.	Clear the pipe.
	The suction pipe is not connected to the squeegee.	Connect the pipe.
	Voltage is not reaching the suction motor.	Check the fuse and have the motor connections checked.
	Voltage is reaching the suction motor but the motor is not working.	Change the motor.

Possible faults affecting the drive system.

FAULTS	CAUSES	REMEDIES
The machine does not move forward.	The hand brake is engaged.	Release the brake.
	The drive fuse is burnt out.	Identify and remove the cause of the fault and change the fuse.
	The drive motor thermal protection has tripped.	Let it cool for at least half an hour.
	There is fault in the motor or in the control unit.	Have the faulty component identified and replaced.
	The micro switches and/or the potentiometer of the drive motor faulty or incorrectly adjusted.	Change or adjust them.

Possible faults affecting the batteries.

FAULTS	CAUSES	REMEDIES
The accumulator does not ensure the normal work time.	The accumulator poles and terminals are oxidised.	Clean and grease the poles and terminals.
	The electrolyte level is too low.	Add distilled water, topping up each element according to the instructions.
	The batter-charger is not working or insufficient.	See the battery charger instructions.
	Testing with a densimeter reveals considerable differences between the various elements in the same accumulator.	The accumulator has been damaged: change it.
	The machine is being used with too high pressure on the brushes.	Reduce the pressure on the brushes.
The accumulator discharges too fast during use, although it has been recharged according to instructions and when tested, at the end of recharging, with densimeter reveals fully charged.	The accumulator is new and does not give 100% of its expected capacity.	It is necessary to "run in" the accumulator by 20-30 complete charges and discharges to obtain maximum performance.
	The machine is used with maximum capacity for long, continuous periods and the autonomy is not sufficient.	Use, when possible, accumulators with larger capacity or change them after half the job done, with new, already charged ones.
	The electrolyte has evaporated and does not cover the cells completely.	Fill with distilled water, topping up the cells and recharge the accumulator.
The accumulator discharges too fast during use, the recharging with an electronic battery recharger is too fast and after the accumulator shows the correct tension (about 2.14V for each empty element) but reveals discharged when tested with densimeter.	The accumulator, already filled with acid by the manufacturer, has been stored too long before recharged and used the first time.	If the recharging with a normal battery recharger is not efficient enough, a double recharging is needed, consisting of: <ul style="list-style-type: none"> - one slow recharging of ten hours with a current equal to 1/10 of the nominal capacity expressed in 5 hours (for example for a battery of 100Ah(5) the current should be 10A). Use a manual battery recharger; - one hour break; - recharge with a normal recharger.

FAULTS	CAUSES	REMEDIES
After recharging with an electronic recharger the accumulator does not show the correct tension (about 2.14V for an empty element) and reveals discharged when tested with densimeter.	The accumulator has not been connected to the recharger (for example the low tension connector has been wrongly connected to the connector of the machine).	Connect the recharger to the accumulator.
	The recharger and the socket to which it is connected are not compatible.	Verify that the characteristics of the electric supply indicated on the data plate of the recharger are conform with the electric network.
	The recharger is not correctly installed.	Considering the effective tension available, verify that the connections of the primary of the transformer are correct (Consult the recharger's manual for this).
	The recharger does not work.	Verify that the recharger receives tension, that eventual fuses are not burnt and that the accumulator receives current, try also to charge with another rectifier: if the recharge actually does not work, contact a Technical Assistant, leaving the serial number of the recharger.
After recharging with an electronic recharger the accumulator does not show the correct tension (about 2.14V for an empty element) and when tested with a densimeter only one or a few of the elements are discharged.	One or more elements are damaged.	Change, if possible, the damaged elements. The 6V and 12V unicelel accumulators must be changed entirely.
The electrolyte inside the accumulator has a turbid colour.	The accumulator has reached maximum amount or charge/discharge recommended by the manufacturer.	Change the accumulator.
	A too high current has been used when recharging the accumulator.	Change the accumulator.
	The accumulator has been discharged under the minimum level recommended by the manufacturer.	Change the accumulator.

WE RESERVE THE RIGHT TO MODIFY SPECIFICATIONS WITHOUT NOTICE OR OBLIGATION



BETCO

1001 Brown Avenue - Toledo, Ohio 43607 - 1-800-777-9343